

Step 3 Connections

- Turn off all equipment before connection and read the appropriate owner's manual.
- Do not connect the AC power supply cord until all other connections are complete.**

■ HDMI

- The HDMI connection supports VIERA Link "HDAVI Control" (⇒ 25) when used with a compatible Panasonic TV.
- Use the High Speed HDMI Cables. It is recommended that you use Panasonic's HDMI cable.
Recommended part number (High Speed HDMI cable):
RP-CDHS15 (1.5 m/4.9 ft), RP-CDHS30 (3.0 m/9.8 ft), RP-CDHS50 (5.0 m/16.4 ft), etc.
- Non-HDMI-compliant cables cannot be utilized.

Connection with the TV

1 Verify if the TV's HDMI terminal is labeled "HDMI (ARC)".

Connection differs depending on the label printed next to the HDMI terminal.

Labeled "HDMI (ARC)": Connection **A**

Not Labeled "HDMI (ARC)": Connection **B**

■ What is ARC?

ARC is an abbreviation of Audio Return Channel, also known as HDMI ARC. It refers to one of the HDMI functions. When you connect the main unit to the terminal labeled "HDMI (ARC)", the optical digital audio cable that is usually required in order to listen to sound from a TV is no longer required, and TV pictures and sound can be enjoyed with a single HDMI cable.

2 Make the connection.

A Labeled "HDMI (ARC)"

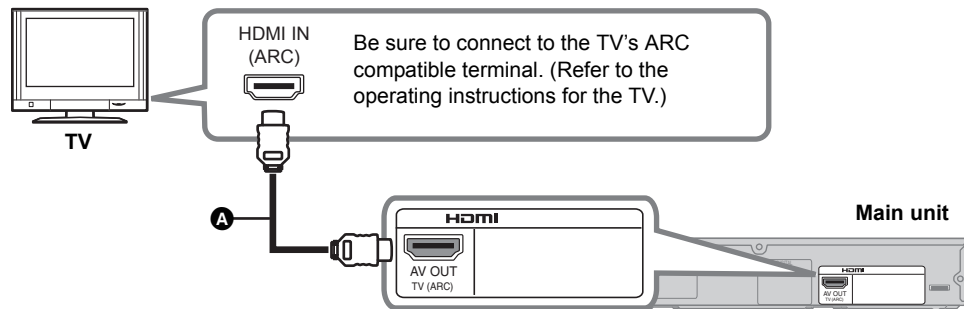

A HDMI cable

B Not labeled "HDMI (ARC)"

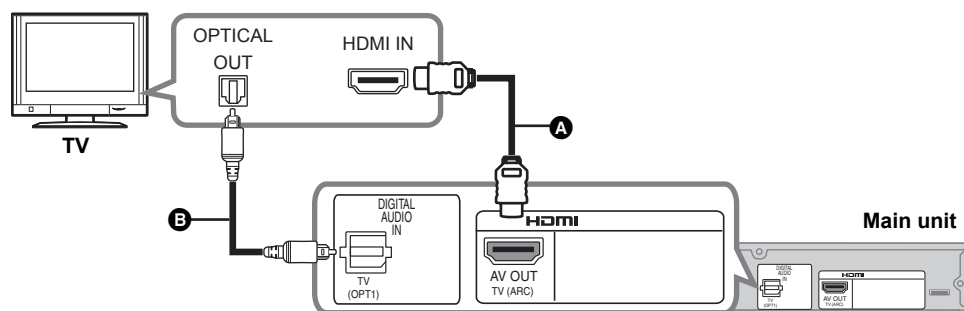

A HDMI cable

B Optical digital audio cable

- When you use the optical digital audio cable, insert the tip correctly into the terminal.

Getting started

Connection with other devices

You can direct the audio signal from the connected Blu-ray Disc player™, DVD player, Set Top Box, etc. to this system.

When the device has an HDMI terminal

Preparation

- Connect the main unit to the TV (⇒ 19).

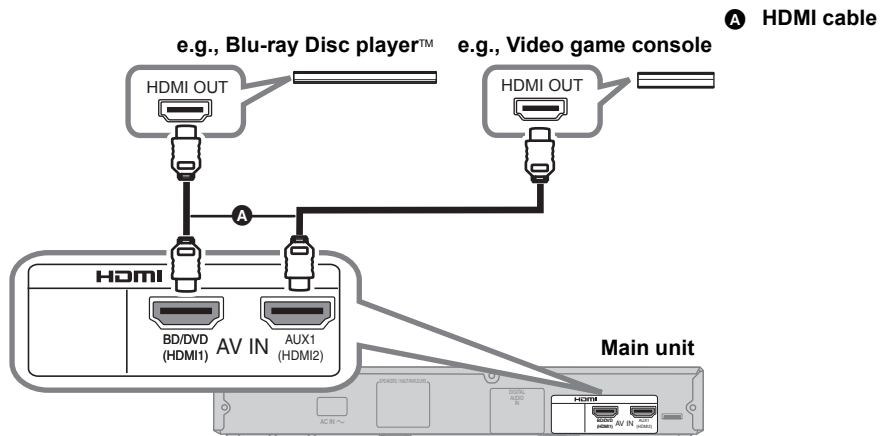

HDMI standby pass-through

Even if the main unit is in standby mode, the audio and/or video signal from the device connected to the BD/DVD or AUX1 terminal will be sent to the TV connected to the HDMI OUT terminal (the sound will not be output from this system). When devices are connected to both BD/DVD and AUX1 terminals, audio and/or video signal of the device whose input is lastly selected is output.

3D compatibility

Compatible with FULL HD 3D TV and Blu-ray Disc player™.

- The main unit can pass the 3D video signal from a 3D compatible Blu-ray Disc player™ to a FULL HD 3D TV.

When the device has an optical digital audio output terminal

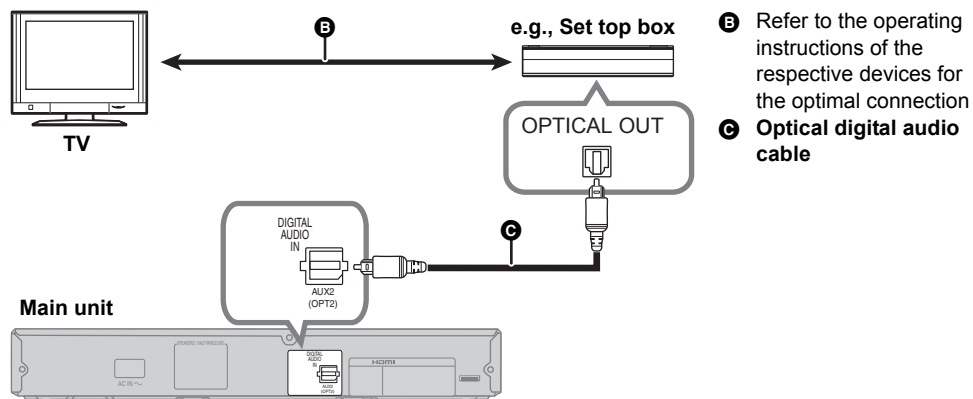

Speaker cable connection

Match the connector shape and connect to the terminals of the same color.

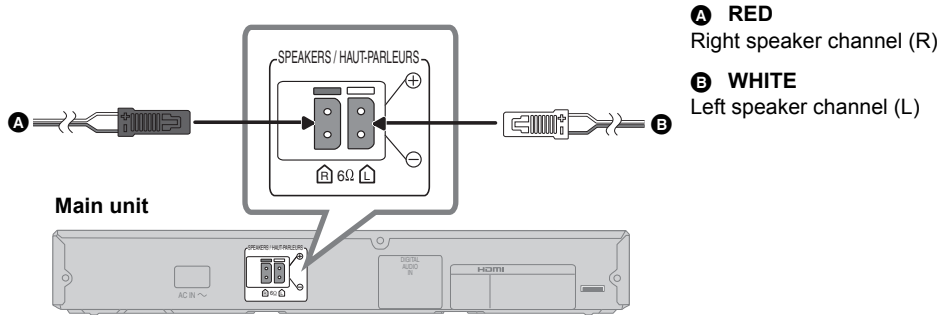

AC power supply cord connection

• Connect only after all other connections are complete.

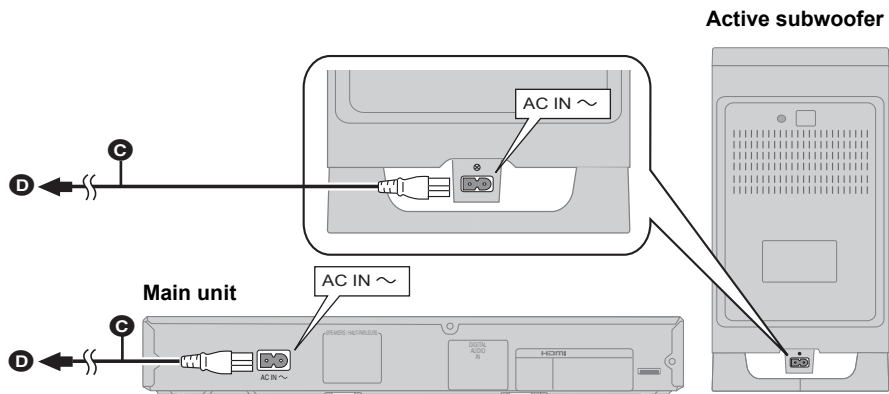

C AC power supply cord **D To a household AC outlet**

• The main unit and active subwoofer consume a small amount of AC power, even when it is turned off (this unit: approx. 0.1 W, active subwoofer: approx. 0.1 W). In the interest of power conservation, if you will not be using this system for a long time, unplug it from the household AC outlet.

Install this unit so that the power cord can be unplugged from the socket outlet immediately if any problem occurs.

Saving energy

The main unit is designed to conserve its power consumption and save energy.

• **The main unit will automatically switch to standby mode** when no signal is input and no operation is performed for approx. 30 minutes.

Getting started

Active subwoofer wireless connection

Preparation

- Turn on the main unit.

1 Press [**⏻** **⏪**].

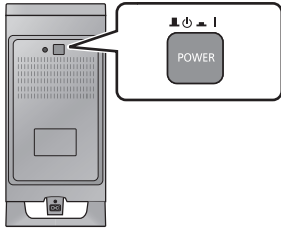

2 Check that the wireless link is activated.

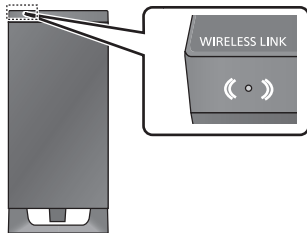

WIRELESS LINK indicator lights

- **Red:**
The wireless link is not activated.
- **Green:**
The wireless link is activated.

The unit will still consume a small amount of power even when it is turned off (**⏻**, **⏻**)

Bluetooth® connection

With the Bluetooth® connection you can output the audio from the connected wireless device.

Preparation

- Turn on the Bluetooth® feature of the device and place the device near this unit.

Pairing a device

1 Press [**Ⓜ**, – PAIRING].

- “**Ⓜ**” indicator will blink quickly.

2 Select “SC-HTB550” from the Bluetooth® device’s Bluetooth® menu.

- Refer to the operating instructions of the Bluetooth® device for further instruction on how to connect a Bluetooth® device.
- Once the Bluetooth® device is connected, the “**Ⓜ**” indicator stops flashing and lights up.



- If prompted for the passkey on the Bluetooth® device, enter “0000”.

Pairing additional devices

1 Press [**Ⓜ**, – PAIRING].

2 Press and hold the [**Ⓜ**, – PAIRING] until the “**Ⓜ**” indicator flashes quickly.

3 Repeat step 2 of “Pairing a device”.



- You can register up to 6 devices with this unit. If a 7th device is paired, the device that has not been used for the longest time will be replaced.
- This unit can only be connected to one device at a time.
- To change the sound quality, refer to “Bluetooth® communication mode” on page 26.

Using this unit

Preparation

- Turn on the TV and/or connected device.



1 Press [⏻] to turn on the main unit.

2 Select the source.

Press	To select
[TV]	"TV"
[📶]	"📶" (Bluetooth®)
[INPUT SELECTOR]	"TV" → "BD/DVD" → "AUX1" ↑ "📶" ← "AUX2" ← ↓

- This remote control cannot be used to control the operations of the connected devices.

■ When "📶" is selected as the source

On the Bluetooth® device:

Select this unit as the output source of the Bluetooth® device and start the playback.

- Make sure that the Bluetooth® device is already paired with this unit. (⇒ 22)
- Playback may pause when a different source is selected.

■ When "BD/DVD" or "AUX1" is selected as the source

On the connected device:

Select the TV's input for this unit and start the playback on the connected device.

■ When "AUX2" is selected as the source

On the connected device:

Select the TV's input for the device connected to "AUX2" terminal and start the playback on the connected device.



If the main unit does not operate as expected or sound is unusual, return the settings to the factory preset and operate the system again. (⇒ 28)

※ The audio format indicators blink from left to right (+) or from right to left (−) while adjusting.

The indicators will not blink when it has reached the maximum or minimum.

- If there is sound coming out of the TV's speakers, reduce the volume of the TV to its minimum.
- If the main unit is turned off with the volume setting in the greater half (above 50), the main unit will automatically lower the volume to the middle (50) when the main unit is turned on (Volume limitation). To turn this function off, refer to page 27.

3 Adjust the volume and sound effect level.

■ To adjust the volume of the system

Press [+ VOL −].

- Volume range: 1 to 100*

■ To adjust the dialog effect level

This setting will change the level of the Clear-mode dialog effect. (⇒ 24)

- 1 Press [+ DIALOG LEVEL −] to display the current level.
- 2 While the level is displayed: Press [+ DIALOG LEVEL −] to adjust the level.*

Indication	Effect level
	4 Highest
	3
	2
	1 Lowest

■ To adjust the subwoofer level

- 1 Press [+ SUBWOOFER −] to display the current level.
- 2 While the level is displayed: Press [+ SUBWOOFER −] to adjust the level.*

- The level indication pattern is the same as dialog effect level.

■ To mute the sound

Press [MUTE]

- While muting, the audio format indicators blink simultaneously.
- To cancel, press the button again or adjust the volume.
- Muting is canceled if the main unit is turned off.

3D sound

This system provides a feeling that the sound and the image are as one. The 3D sound effect will be applied to Multi-channel audio sources as a factory preset.

e.g., Image of 3D sound field

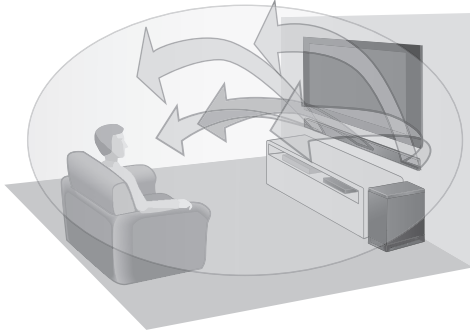

3D sound	
Dolby Virtual Speaker	With this effect you can enjoy a surround sound effect similar to 5.1ch.
3D surround effect	Adding to the Dolby Virtual Speaker effect, Panasonic has applied its own sound field controlling technology to expand the sound field forwards, backwards, upwards, and downwards, providing a sound with depth and force that better matches 3D images.
Clear-mode dialog	Sports commentary and dialogs from TV dramas are heard as if the sound is coming from the TV, giving the feeling that the sound and the image are one. Also, the dialog will stand out from the other sounds during normal volume playback and when the volume is lowered for night time viewing.



Dolby Virtual Speaker and the 3D surround effects can be turned off and on by changing the audio output mode settings.

Audio output modes

As a factory preset, Dolby Virtual Speaker and the 3D surround effects will be applied to Multi-channel audio sources, such as those from a Blu-ray Disc player™ or DVD player, etc.

By changing the audio output setting, it is possible to apply the Dolby Virtual Speaker and 3D surround effects to 2ch audio sources, such as the audio from the TV.

To change the audio output mode

1 Press and hold [MUTE] for more than 2 sec.

- The indicator for the current setting blinks for 10 sec.

2 While the indicator is blinking, press [MUTE] again to change the setting.

- The setting changes each time [MUTE] is pressed.

Audio output mode	Dolby Virtual Speaker and 3D surround effect
Multi-channel mode 	The effects are applied to all audio sources.
Auto mode (Direct mode)*1 (Factory preset) 	The effects are applied to Multi-channel audio sources. The effects are not applied to 2 channel audio sources.
2ch mode 	The effects are not applied to any audio source.

*1 Depending on the audio source, Dolby Virtual Speaker and 3D surround effect settings are automatically adjusted.

*2 This indicator will also light when the audio source is Multi-channel audio.



When using the optical digital audio cable, Dolby Virtual Speaker and the 3D surround effect will be temporarily canceled if the audio signal's sampling frequency is greater than 48 kHz.

Linked operations with the TV (VIERA Link™ “HDAVI Control™”)

What is VIERA Link “HDAVI Control”?

VIERA Link™ is a new name for EZ Sync™. VIERA Link “HDAVI Control” is a convenient function that offers linked operations of this unit, and a Panasonic TV (VIERA) under “HDAVI Control”.

You can use this function by connecting the equipment with an HDMI cable. See the operating instructions for connected equipment for operational details.

Preparation

- ① Confirm that the HDMI connection has been made. (⇒ 19)
- ② Set the “HDAVI Control” operations on the connected equipment (e.g., TV).
- ③ For the optimal “HDAVI Control” operations change the following settings on the connected TV^{#1}.
 - Set the default speaker settings to this system.^{#2}
 - Set the speaker selection settings to this system.
- ④ Turn on all “HDAVI Control” compatible equipment and select the TV’s input for this system so that the “HDAVI Control” function works properly.
- ⑤ If a device is connected to the HDMI IN terminal, start play to check that the picture is displayed on the TV correctly.

When the connection or settings are changed, repeat this procedure.

- ※1 The availability and function of the settings may vary depending on the TV. Refer to the operating instructions for the TV for details.
- ※2 If the TV has a default speaker setting within the VIERA Link setting items, choosing this system as the default speaker will automatically change the speaker selection to this system.



- VIERA Link “HDAVI Control”, based on the control functions provided by HDMI which is an industry standard known as HDMI CEC (Consumer Electronics Control), is a unique function that we have developed and added. As such, its operation with other manufacturers’ equipment that supports HDMI CEC cannot be guaranteed.
- This unit supports “HDAVI Control 5” function. “HDAVI Control 5” is the newest standard (current as of November, 2011) for Panasonic’s HDAVI Control compatible equipment. This standard is compatible with Panasonic’s conventional HDAVI equipment.
- Please refer to individual manuals for other manufacturers’ equipment supporting VIERA Link function.

What you can do with VIERA Link “HDAVI Control”

To make sure that the audio is output from this system, turn the main unit on by using the TV’s remote control and selecting home theater from the speaker menu of VIERA Link menu. The availability and function of the settings may vary depending on the TV. Refer to the operating instructions for the TV for details.

■ Speaker control

You can select whether audio output is from this system or the TV speakers by using the TV menu settings.

Home theater

This system is active.

- When this system is in standby mode, changing the TV speakers to this system in the VIERA Link menu will automatically turn this system on and select TV as the source.
- You can control the volume setting of this system using the volume or mute button on the TV remote control.
- If you turn off this system, TV speakers will be automatically activated.
- Audio will automatically be output from this system if the TV is compatible to VIERA Link “HDAVI Control 4” or later.

TV

TV speakers are active.

- The volume of this system is set to its minimum.

■ Automatic input switching

When the following operations are performed, this system will automatically change the input to the corresponding source.

- When play starts on an HDMI connected device.^{#3}
- When the TV input or the TV channel is changed.

- ※3 If the speaker output setting on the TV is set to this system, the TV and this system turn on automatically (Power on link).

■ Power off link

When the TV is turned off, the main unit also turns off automatically. (This function does not work when Bluetooth® is the source.)

■ Automatic lip-sync function (for HDAVI Control 3 or later)

Delay between audio and video is automatically adjusted by adding time-lag to the audio output, enabling you to enjoy smooth audio for the picture.



The delay information is automatically set if the TV is compatible to VIERA Link “HDAVI Control 3” or later and the VIERA Link is set to on.

Advanced operations

Changing the dual audio

Change the dual audio from main to secondary.

- 1 **Confirm the digital audio output setting on the connected TV or player, etc. is set to "Bitstream".**
- 2 **Press and hold [TV] for more than 2 sec.**
- 3 **While the indicator of the current setting is blinking, press [TV] to change the setting.**

- The indicator for the current setting blinks for 10 sec.



A : Main



B : Secondary
(SAP: Secondary Audio Program)

A, **B** : Main and secondary

- The setting works only when the dual audio is available in the audio source.
- The setting is maintained until it is changed again.
- The same setting is used for all digital audio sources.

Auto gain control

With this function, you can prevent sudden loud sounds. The output will be reduced automatically when the input exceeds a certain level.

- 1 **Press and hold [INPUT SELECTOR] on remote controller for more than 2 sec.**

- The indicator for the current setting blinks for 10 sec.



Dolby Digital indicator blinks:
Auto gain control is on.



PCM indicator blinks:
Auto gain control is off.

- 2 **While the indicator is blinking, press [INPUT SELECTOR] to change the setting.**

- The setting changes each time [INPUT SELECTOR] is pressed.
- The setting is maintained until it is changed again.
- Default setting of this function is OFF.

Bluetooth® communication mode

You can select different modes to suit the type of connections which emphasis on connectivity or high quality audio.

- Make sure that a Bluetooth® device is already paired with this unit. (⇒ 22)

- 1 **Disable the Bluetooth® connection of the device.**

- "BT" indicator will blink slowly.

- 2 **Press [LINK MODE, BT] to display the current mode.**

- The indicator for the current setting blinks for 10 sec.



MODE1: (Factory preset)
Emphasis on connectivity



MODE2:
Emphasis on audio quality

- 3 **While the mode is displayed, press [LINK MODE, BT] to select the mode.**

- The setting changes each time [LINK MODE, BT] is pressed.
- The setting is maintained until it is changed again.

To turn off the 3D surround effect and clear-mode dialog effect

Depending on your preference, It is possible to use only the Dolby Virtual Speaker effect by turning off the 3D surround effect and the clear-mode dialog effect.

- 1 **Press and hold [TV] on the remote control and [VOL +] on the main unit for more than 2 sec.**

- The indicator for the current setting blinks for 10 sec.



Dolby Digital indicator blinks:
3D surround effect and clear-mode dialog effect is on.



PCM indicator blinks:
3D surround effect and clear-mode dialog effect is off.

- 2 **While the indicator is blinking, press [TV] to change the setting.**

- The setting changes each time [TV] is pressed.
- This setting will be reset to on when this system is turned off.
- When off is selected, the dialog effect level cannot be adjusted.

Others

The following settings are unnecessary under general usage conditions of the system.

Remote control code

When other Panasonic devices respond to this system's remote control, change the remote control code on the main unit and the remote control.

Preparation

- Turn off all other Panasonic products.
- Turn on the main unit.

Change the remote control code to code 2:

- 1 Aim the remote control at this system's remote control sensor.
- 2 Press and hold [MUTE] and [Ⓜ] on the remote control for more than 4 sec.

- All the indicators will blink for 10 sec when the code of this system is changed.



- The setting is maintained until it is changed again.



- If this system does not operate after changing the code, repeat steps 1 and 2.
- To change the remote control code to code 1, repeat the steps above, but replace [Ⓜ] with [TV].

To reduce the clear-mode dialog effect

When the dialog does not sound natural while the volume is set low, for example, It is possible to reduce the dialog enhancing effect as follows:

Press and hold [TV] on the remote control and [– VOL] on the main unit for more than 2 sec.

- All the indicators will blink once when the clear-mode dialog effect is reduced.

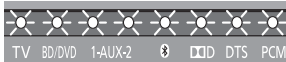

- Even if clear-mode dialog effect is reduced, dialog effect level is still adjustable.

To turn off VIERA Link “HDAVI Control”

When “HDAVI Control” compatible equipment does not work well with this system, for example, it is possible to turn off this function as follows:

- When VIERA Link is turned off the ARC function is not available. Be sure to connect the optical digital audio cable. (⇒ 19)

- 1 Press and hold [MUTE] on the remote control and [– VOL] on the main unit for more than 2 sec.
- 2 After the setting has changed, turn off all the connected devices and then turn them on again.

- All the indicators will blink once when VIERA Link “HDAVI Control” is turned off.



To turn off the volume limitation

If a state of the lowered volume disturbs you every time this system turns on, for example, it is possible to turn off this function as follows:

Press and hold [MUTE] on the remote control and [VOL +] on the main unit for more than 2 sec.

- All the indicators will blink once when the volume limitation is turned off.



The settings of the clear-mode dialog effect, VIERA Link “HDAVI Control”, and the volume limitation remain intact even if you switch this system to standby mode. To turn these 3 functions back on, this system must be set back to the factory preset. (⇒ 28)

Troubleshooting

Before requesting service, make the following checks. If you are in doubt about some of the check points, or if the solutions indicated in the following guide do not solve the problem, refer to "Customer Services Directory (United States and Puerto Rico)" on page 34 if you reside in the U.S.A. or Puerto Rico, or refer to "WARRANTY SERVICE" on page 35 if you reside in Canada.

To return to the factory preset.

While the main unit is on, press [⏻/I] on the main unit for more than 4 sec.
(All the indicators will blink twice when the main unit is reset.)

If the system does not operate as expected, returning the settings to the factory preset may solve the problem.

- The remote control code will return to "1" when the main unit is returned to the factory preset. To change the remote control code, refer to page 27.

General operation

No power.

- Insert the AC power supply cord securely. (⇒ 21)
- After turning the main unit on, if the indicators blink and the main unit immediately turns off, unplug the AC power supply cord and consult your dealer.

The remote control does not work properly.

- The battery is depleted. Replace it with a new one. (⇒ 7)
- It is possible that the insulation sheet has not been removed. Remove the insulation sheet. (⇒ 7)
- It may be necessary to set the code of the remote control again after changing the battery of the remote control. (⇒ 27)
- Use the remote control within the correct operation range. (⇒ 7)

The "TV" indicator blinks.

Remove the AC power supply cord and consult your dealer. If there are any other indicators blinking, be sure to inform your dealer about the blinking indicators.

The main unit is automatically switched to standby mode.

The main unit will automatically switch to standby mode when no signal is input and no operation is performed for approx. 30 minutes. (⇒ 21)

The main unit is turned off when the TV's speakers are selected in the speaker control.

This is a normal feature when using VIERA Link (HDAVI Control 4 or later). Please read the operating instructions for the TV for details about its power save feature. (⇒ 25)

HDMI

This system does not operate correctly.

If the HDMI cable is connected to the wrong terminal (HDMI IN or HDMI OUT), this system will not operate correctly. Turn the main unit off, disconnect the AC power supply cord and reconnect the HDMI cable(s). (⇒ 19)

VIERA Link related operations no longer function properly.

- Check the VIERA Link setting on the connected devices.
- Have you turned the VIERA Link settings off? (⇒ 27)
- When the HDMI connections are changed, after a power failure or after the AC power supply cord has been removed, VIERA Link operations may not function properly.
 - Turn on all the devices that are connected to the TV with an HDMI cable and then turn the TV on.
 - Turn off the VIERA Link settings of the TV and turn it on again. For details refer to the operating instructions for the TV.
 - While this system and the TV are connected with the HDMI cable, turn on the TV and then remove the main unit's AC power supply cord and reconnect it again.

The first few seconds of audio cannot be heard when using the HDMI connection.

This may occur during DVD-Video chapter playback. Change the digital audio output setting on the connected device from "Bitstream" to "PCM".

When operating an HDMI compatible device of a different brand, the main unit reacts in an unwanted manner.

HDAVI Control commands may use a different signal depending on the brand of the device. In this case, turn VIERA Link off. (⇒ 27)

Bluetooth®

Pairing cannot be done.

Check the Bluetooth® device condition.

The device cannot be connected.

- The pairing of the device was unsuccessful. Try pairing the device again.
- The pairing of the device has been replaced. Pair the device again. (⇒ 22)
- The system might be connected to a different device. Disconnect the other device and try pairing the device again.

The device is connected but audio cannot be heard through the system.

For some built-in Bluetooth® devices, you have to set the audio output to "SC-HTB550" manually. Read the operating instructions for the device for details.

Sound from the device is uneven.

- The device is out of the 10 m (33 ft) communication range. Bring the device closer to the main unit.
- Remove any obstacle between the main unit and the device.
- Switch off any wireless LAN device.
- Select "MODE 1" for stable communication. (⇒ 26)

Sound**No sound (or image).**

- Turn muting off. (⇒ 23)
- Check the connections to the other devices. (⇒ 19)
- Make sure that the received audio signal is compatible with this system. (⇒ 32)
- Turn this system off and then on again.
- If this system is connected to the TV with only an HDMI cable, make sure that the TV's HDMI terminal is labeled "HDMI (ARC)". If not, connect using the optical digital audio cable. (⇒ 19)
- If this system is connected to a Panasonic TV and turned on using the button on the main unit or the remote control, sound might not be output from this system. In this case, turn the main unit on using the TV's remote control. (⇒ 25)
- If the connections are correct, there might be a problem with the cables. Redo the connections with different cables.
- Check the audio output settings on the connected device.
- If the AUX1 indicator flashes and there is no audio output, try the following.
 - ① Turn the connected device off and then on.
 - ② Turn off this system, remove the HDMI cable, then reconnect the HDMI cable and turn this system back on.

The dual audio cannot be changed from main to secondary.

If the audio received from the connected device is not "Dolby Dual Mono" or the output setting is not "Bitstream", the setting cannot be changed from this system. Change the setting on the connected device.

The volume is lowered when this system is turned on.

If the main unit is turned off with the volume setting in the greater half (above 50), the main unit will automatically lower the volume to the middle (50) when the main unit is turned on. (⇒ 27)

The dialog is too persistent or the dialog does not sound natural.

This system has a function to make the dialog stand out when the volume is low. (⇒ 27)

There is no audio.**The power of the main unit turns off automatically.**

(When the main unit detects a problem, a safety measure is activated and the main unit automatically switches to standby mode.)

- There is a problem with the amplifier.
- Is the volume extremely high?
If so, lower the volume.
- Is this system placed in an extremely hot place?
If so, move this system to a cooler place and wait a few moments and then try to turn it on again.

If the problem persists, confirm the TV indicator and AUX1 indicator blink, turn the system off, remove the AC power supply cord and consult your dealer. Please be sure to remember the indicators that were blinking and inform the dealer.

Active Subwoofer**No power.**

Ensure the AC power supply cord of the active subwoofer is connected properly.

After turning the subwoofer on, it immediately turns off.

Unplug the AC power supply cord and consult your dealer.

No sound from the subwoofer.









- Check that the active subwoofer is turned on.
- Check that the wireless link indicator lights green. (⇒ 22)

The wireless link indicator lights red.

- There is no link between this unit and the active subwoofer.
 - Check that this unit is turned on.
 - Turn the active subwoofer off and then back on. Alternatively, turn the active subwoofer off, disconnect the AC power supply cord and then reconnect it.
- The active subwoofer and the main unit may not be paired correctly. Try the following operation. (Wireless pairing)
 - ① Turn on the main unit and active subwoofer.
 - ② Press [ID SET] on the rear of the active subwoofer. (The WIRELESS LINK indicator will light red and green alternately.)
 - ③ Press and hold [INPUT SELECTOR] on remote control and [VOL +] on the main unit for more than 2 sec. (The BD/DVD indicator will blink and audio format indicators light up in sequence.)
 - When the wireless pairing is successful, BD/DVD indicator will stop flashing and WIRELESS LINK indicator lights green.
 - ④ Turn the main unit off and on.
- Consult your dealer if the problem persists.

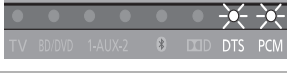
Indicator illumination

The indicators display the condition of this system by flashing. The indicator patterns illustrated below are displayed during normal operational conditions. They do not refer to the indications of a problem. Refer to "Troubleshooting" (⇒ 28) if the indicators do not light up as illustrated below.

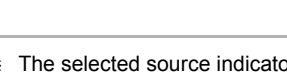
Indicator	Description
	<p>The indicators blink from left to right (+) or from right to left (-).</p> <ul style="list-style-type: none"> When the speaker volume, the dialog effect level, or the subwoofer level is adjusted (⇒ 23)
	<p>The indicators blink simultaneously.</p> <ul style="list-style-type: none"> When "MUTE" is on (⇒ 23)
	<p>The indicator blinks for 10 sec.</p> <ul style="list-style-type: none"> When the audio output mode is Multi-channel mode (⇒ 24) When 3D surround effect and clear-mode dialog effect are on (⇒ 26) When the dual audio setting is Main (⇒ 26) When the auto gain control is on (⇒ 26) When the Bluetooth® communication is mode 1 (⇒ 26) When the dialog effect level or the subwoofer level is 1 (⇒ 23)
	<p>The indicators blink for 10 sec.</p> <ul style="list-style-type: none"> When the audio output mode is Auto mode (⇒ 24) When the dialog effect level or the subwoofer level is 2 (⇒ 23)
	<p>The indicator blinks for 10 sec.</p> <ul style="list-style-type: none"> When the audio output mode is Auto mode (⇒ 24)
	<p>The indicators blink for 10 sec.</p> <ul style="list-style-type: none"> When the dialog effect level or the subwoofer level is 3 (⇒ 23)
	<p>The indicator blinks for 10 sec.</p> <ul style="list-style-type: none"> When the audio output mode is 2ch mode (⇒ 24) When 3D surround effect and clear-mode dialog effect are off (⇒ 26) When the dual audio setting is Secondary (SAP: Secondary Audio Program) (⇒ 26) When the auto gain control is off (⇒ 26) When the Bluetooth® communication is mode 2 (⇒ 26) When the dialog effect level or the subwoofer level is 4 (⇒ 23)
	<p>The indicators blink for 10 sec.</p> <ul style="list-style-type: none"> When the dual audio setting is Main and Secondary (⇒ 26)
	<p>The indicators blink for 10 sec.</p> <ul style="list-style-type: none"> When the remote control code is changed (⇒ 27)
	<p>The indicators blink once.</p> <ul style="list-style-type: none"> When changing the setting ("To reduce the clear-mode dialog effect", "To turn off VIERA Link "HDAVI Control"", and "To turn off the volume limitation") (⇒ 27)
	<p>Bluetooth® indicator blinks quickly.</p> <ul style="list-style-type: none"> When the main unit is ready for pairing <p>Bluetooth® indicator blinks slowly.</p> <ul style="list-style-type: none"> When the main unit is waiting to connect <p>Bluetooth® indicator turns on.</p> <ul style="list-style-type: none"> When the main unit is connected with a Bluetooth® device

※ The selected source indicator will also light.

About Bluetooth®

Panasonic bears no responsibility for data and/or information that is compromised during a wireless transmission.

■ Frequency band used

This unit uses the 2.4 GHz frequency band.

■ Certification of this device

- This system conforms to frequency restrictions and has received certification based on frequency laws. Thus, a wireless permit is not necessary.
- The action below are punishable by law in some countries:
 - Taking apart or modifying the unit.
 - Removing specification indications.

■ Restrictions of use

- Wireless transmission and/or usage with all Bluetooth® equipped devices is not guaranteed.
- All devices must conform to standards set by Bluetooth SIG, Inc.
- Depending on the specifications and settings of a device, it can fail to connect or some operations can be different.
- This system supports Bluetooth® security features. But depending on the operating environment and/or settings, this security is possibly not sufficient. Transmit data wirelessly to this system with caution.
- This system cannot transmit data to a Bluetooth® device.

■ Range of use

Use this device at a maximum range of 10 m (33 ft). The range can decrease depending on the environment, obstacles or interference.

■ Interference from other devices

- When other devices use the same frequency as this system, this system may operate incorrectly or the sound may be distorted.
- To prevent interference from other devices:
 - Keep the system away from other devices that emit radio frequency interference.
 - Do not use this system and a wireless LAN device at the same time. Switch off any wireless LAN device.

■ Intended usage

- This unit is for normal, general use only.
- Do not use this system near an equipment or in an environment that is sensitive to radio frequency interference (example: airports, hospitals, laboratories, etc).

Unit care

■ Clean the system with a soft, dry cloth

- When dirt is heavy, wring a cloth moistened in water tightly to wipe the dirt, and then wipe it with a dry cloth.
- When cleaning the system, use a fine cloth. Do not use tissues or other materials (towels, etc.) that can fall apart. Small grains may get stuck inside the speaker cover.
- Never use alcohol, paint thinner or benzine to clean the system.
- Before using chemically-treated cloth, carefully read the instructions that came with the cloth.

Manufactured under license from Dolby Laboratories. Dolby, Pro Logic, and the double-D symbol are trademarks of Dolby Laboratories.

Manufactured under license under U.S. Patent Nos: 5,956,674; 5,974,380; 6,487,535 & other U.S. and worldwide patents issued & pending. DTS, the Symbol, & DTS and the Symbol together are registered trademarks & DTS Digital Surround and the DTS logos are trademarks of DTS, Inc. Product includes software. © DTS, Inc. All Rights Reserved.

HDMI, the HDMI Logo, and High-Definition Multimedia Interface are trademarks or registered trademarks of HDMI Licensing LLC in the United States and other countries.

HDAVI Control™ is a trademark of Panasonic Corporation.

VIERA Link™ is a trademark of Panasonic Corporation.

EZ Sync™ is a trademark of Panasonic Corporation.

The Bluetooth® word mark and logos are owned by the Bluetooth SIG, Inc. and any use of such marks by Panasonic Corporation is under license. Other trademarks and trade names are those of their respective owners.

Specifications

AMPLIFIER SECTION

RMS output power	
10 % total harmonic distortion	
Subwoofer ch	120 W per channel (100 Hz, 8 Ω)
Front ch (L, R ch)	60 W per channel (1 kHz, 6 Ω)
Total RMS Dolby Digital mode power	240 W
FTC output power	
1.0 % total harmonic distortion	
Subwoofer ch	60 Hz to 120 Hz 40 W (8 Ω)
Front ch (L, R ch)	120 Hz to 20 kHz 25 W (6 Ω)
Total FTC Dolby Digital mode power	90 W

WIRELESS SECTION

Wireless module	
Frequency Range	5.150 GHz to 5.250 GHz 5.725 GHz to 5.850 GHz
Number of channels	9

TERMINAL SECTION

HDAVI Control	
This unit supports "HDAVI Control 5" function.	
HDMI AV input (BD/DVD, AUX1)	2
Input connector	Type A (19 pin)
HDMI AV output (TV (ARC))	1
Output connector	Type A (19 pin)
Digital audio input	
Optical digital input (TV, AUX2)	2
Sampling frequency	32 kHz, 44.1 kHz, 48 kHz 88.2 kHz, 96 kHz (only LPCM)
Audio format	LPCM, Dolby Digital, DTS

SPEAKER SECTION

Front speakers	
2 way, 2 speaker system (Bass reflex type)	
Speaker unit(s)	Impedance 6 Ω
Woofers	6.5 cm (2 1/2") cone type×1
Tweeter	2.5 cm (1") semi-dome type×1
Frequency range	100 Hz to 30 kHz (−16 dB) 150 Hz to 25 kHz (−10 dB)
Active subwoofer	
1 way, 1 speaker system (Bass reflex type)	
Woofers	16 cm (6 1/2") cone type×1
Frequency range	30 Hz to 180 Hz (−16 dB) 35 Hz to 160 Hz (−10 dB)

GENERAL

Power consumption	Main unit: 29 W Active subwoofer: 21 W
In standby condition	Main unit: Approx. 0.1 W Active subwoofer: Approx. 0.1 W
Power supply	AC 120 V, 60 Hz
Dimensions (W×H×D)	
Main unit	
Cabinet dimension	310 mm×44 mm×195 mm (12 7/32"×1 23/32"×7 11/16")
Maximum outer dimension	310 mm×45 mm×202 mm (12 7/32"×1 25/32"×7 15/16")
Active subwoofer	180 mm×408 mm×306 mm (7 3/32"×16 1/16"×12 1/16")
Mass (Weight)	
Main unit	1.1 kg (2.4 lbs)
Active subwoofer	5.2 kg (11.47 lbs)
Operating temperature range	0 °C to +40 °C (+32 °F to +104 °F)
Operating humidity range	20 % to 80 % RH (no condensation)

SPEAKER GENERAL

Horizontal placement using the stands

Dimensions (W×H×D)

956 mm×102 mm×74 mm
(37 5/8"×4 1/32"×2 29/32")

Mass (Weight)

1.61 kg (3.7 lbs)

Horizontal placement using the speaker feet and the support legs

Dimensions (W×H×D)

956 mm×78 mm×55 mm
(37 5/8"×3 1/16"×2 5/32")

Mass (Weight)

1.57 kg (3.5 lbs)

Horizontal placement (for wall mount)

Dimensions (W×H×D)

956 mm×75 mm×35 mm
(37 5/8"×2 15/16"×1 3/8")

Mass (Weight)

1.54 kg (3.5 lbs)

Vertical placement using the speaker bases

Dimensions (W×H×D)

148 mm×528 mm×145 mm
(5 13/16"×20 25/32"×5 23/32")

Mass (Weight)

0.88 kg (1.98 lbs)

Vertical placement (for wall mount)

Dimensions (W×H×D)

75 mm×478 mm×35 mm
(2 15/16"×18 13/16"×1 3/8")

Mass (Weight)

0.77 kg (1.76 lbs)

Bluetooth® SECTION

Bluetooth® system specification

V2.1 + EDR

Wireless equipment classification

Class 2 (2.5 mW)

Supported profiles

A2DP, AVRCP

Frequency band

2402 MHz to 2480 MHz
(Adaptive Frequency Hopping)

Operating distance

10 m (33 ft) Line of Sight



- 1 Specifications are subject to change without notice.
- 2 Weight and dimensions are approximate.
- 3 Total harmonic distortion is measured by a digital spectrum analyzer.

Limited Warranty (ONLY FOR U.S.A. AND PUERTO RICO)

Panasonic Consumer Marketing Company of North America,
Division of Panasonic Corporation of North America
One Panasonic Way, Secaucus, New Jersey 07094

Panasonic Home Audio Products Limited Warranty

Limited Warranty Coverage (For USA and Puerto Rico Only)

If your product does not work properly because of a defect in materials or workmanship, Panasonic Consumer Marketing Company of North America (referred to as "the warrantor") will, for the length of the period indicated on the chart below, which starts with the date of original purchase ("warranty period"), at its option either (a) repair your product with new or refurbished parts, (b) replace it with a new or a refurbished equivalent value product, or (c) refund your purchase price. The decision to repair, replace or refund will be made by the warrantor.

Product or Part Name	Parts	Labor
Audio Products (except items below)	1 year	1 year
DVD Home Theater System	1 year	1 year
Home Theater Audio System	1 year	1 year
SD Memory Cards, Rechargeable Battery Packs (defective exchange)	90 days	Not Applicable

During the "Labor" warranty period there will be no charge for labor. During the "Parts" warranty period, there will be no charge for parts. This Limited Warranty excludes both parts and labor for non-rechargeable batteries, antennas, and cosmetic parts (cabinet). This warranty only applies to products purchased and serviced in the United States or Puerto Rico. This warranty is extended only to the original purchaser of a new product which was not sold "as is".

Carry-In or Mail-In Service

To find a service center please visit <http://www.panasonic.com/help> or call 1-800-211-PANA (7262).

When shipping the unit, carefully pack, include all supplied accessories listed in the Owner's Manual, and send it prepaid, adequately insured and packed well in a carton box. When shipping Lithium Ion batteries please visit our Web Site at www.panasonic.com/BatteryHandling as Panasonic is committed to providing the most up to date information. Include a letter detailing the complaint, a return address and provide a daytime phone number where you can be reached. A valid registered receipt is required under the Limited Warranty.

IF REPAIR IS NEEDED DURING THE WARRANTY PERIOD, THE PURCHASER WILL BE REQUIRED TO FURNISH A SALES RECEIPT/ PROOF OF PURCHASE INDICATING DATE OF PURCHASE, AMOUNT PAID AND PLACE OF PURCHASE. CUSTOMER WILL BE CHARGED FOR THE REPAIR OF ANY UNIT RECEIVED WITHOUT SUCH PROOF OF PURCHASE.

Limited Warranty Limits And Exclusions

This warranty ONLY COVERS failures due to defects in materials or workmanship, and DOES NOT COVER normal wear and tear or cosmetic damage. The warranty ALSO DOES NOT COVER damages which occurred in shipment, or failures which are caused by products not supplied by the warrantor, or failures which result from accidents, misuse, abuse, neglect, mishandling, misapplication, alteration, faulty installation, set-up adjustments, misadjustment of consumer controls, improper maintenance, power line surge, lightning damage, modification, introduction of sand, humidity or liquids, commercial use such as hotel, office, restaurant,

The model number and serial number of this product can be found on either the back or the bottom of the unit. Please note them in the space provided below and keep for future reference.

MODEL NUMBER SC-HTB550
SERIAL NUMBER _____

or other business or rental use of the product, or service by anyone other than a Factory Service Center or other Authorized Servicer, or damage that is attributable to acts of God.

THERE ARE NO EXPRESS WARRANTIES EXCEPT AS LISTED UNDER "LIMITED WARRANTY COVERAGE". THE WARRANTOR IS NOT LIABLE FOR INCIDENTAL OR CONSEQUENTIAL DAMAGES RESULTING FROM THE USE OF THIS PRODUCT, OR ARISING OUT OF ANY BREACH OF THIS WARRANTY.

(As examples, this excludes damages for lost time, travel to and from the servicer, loss of or damage to media or images, data or other memory or recorded content. The items listed are not exclusive, but for illustration only.) **ALL EXPRESS AND IMPLIED WARRANTIES, INCLUDING THE WARRANTY OF MERCHANTABILITY, ARE LIMITED TO THE PERIOD OF THE LIMITED WARRANTY.**

Some states do not allow the exclusion or limitation of incidental or consequential damages, or limitations on how long an implied warranty lasts, so the exclusions may not apply to you.

This warranty gives you specific legal rights and you may also have other rights which vary from state to state. If a problem with this product develops during or after the warranty period, you may contact your dealer or Service Center. If the problem is not handled to your satisfaction, then write to the warrantor's Consumer Affairs Department at the addresses listed for the warrantor.

PARTS AND SERVICE, WHICH ARE NOT COVERED BY THIS LIMITED WARRANTY, ARE YOUR RESPONSIBILITY.

Customer Services Directory (United States and Puerto Rico)

Obtain Product Information and Operating Assistance; locate your nearest Dealer or Service Center; purchase Parts and Accessories; or make Customer Service and Literature requests by visiting our Web Site at: <http://www.panasonic.com/help> or, contact us via the web at: <http://www.panasonic.com/contactinfo>
You may also contact us directly at:
1-800-211-PANA (7262)
Monday-Friday 9am-9pm,
Saturday-Sunday 10am-7pm EST

For hearing or speech impaired TTY users, TTY: 1-877-833-8855

Accessory Purchases (United States and Puerto Rico)

Purchase Parts, Accessories and Instruction Books online for all Panasonic Products by visiting our Web Site at: <http://www.pstc.panasonic.com>
Or, send your request by E-mail to: npparts@us.panasonic.com
You may also contact us directly at:
1-800-332-5368 (Phone) 1-800-237-9080 (Fax Only)
(Monday-Friday 9am-9pm EST)
Panasonic National Parts Center
20421 84th Ave S., Kent, WA 98032
(We accept Visa, MasterCard, Discover Card, American Express)

For hearing or speech impaired TTY users, TTY: 1-866-605-1277

As of January 2012

User memo:

DATE OF PURCHASE _____
DEALER NAME _____
DEALER ADDRESS _____
TELEPHONE NUMBER _____

Limited Warranty (ONLY FOR CANADA)

Panasonic Canada Inc.
5770 Ambler Drive, Mississauga, Ontario L4W 2T3

PANASONIC PRODUCT - LIMITED WARRANTY

Panasonic Canada Inc. warrants this product to be free from defects in material and workmanship under normal use and for a period as stated below from the date of original purchase agrees to, at its option either (a) repair your product with new or refurbished parts, (b) replace it with a new or a refurbished equivalent value product, or (c) refund your purchase price. The decision to repair, replace or refund will be made by Panasonic Canada Inc.

Technics Audio Product - One (1) year, parts and labour
Panasonic BD/DVD Product - One (1) year, parts and labour
Panasonic Audio Receivers - One (1) year, parts and labour
Home Theater Systems Product - One (1) year, parts and labour

This warranty is given only to the original purchaser, or the person for whom it was purchased as a gift, of a Panasonic brand product mentioned above sold by an authorized Panasonic dealer in Canada and purchased and used in Canada, which product was not sold "as is", and which product was delivered to you in new condition in the original packaging.

IN ORDER TO BE ELIGIBLE TO RECEIVE WARRANTY SERVICE HEREUNDER, A PURCHASE RECEIPT OR OTHER PROOF OF DATE OF ORIGINAL PURCHASE, SHOWING AMOUNT PAID AND PLACE OF PURCHASE IS REQUIRED

LIMITATIONS AND EXCLUSIONS

This warranty ONLY COVERS failures due to defects in materials or workmanship, and DOES NOT COVER normal wear and tear or cosmetic damage. The warranty ALSO DOES NOT COVER damages which occurred in shipment, or failures which are caused by products not supplied by Panasonic Canada Inc., or failures which result from accidents, misuse, abuse, neglect, mishandling, misapplication, alteration, faulty installation, set-up adjustments, misadjustment of consumer controls, improper maintenance, power line surge, lightning damage, modification, introduction of sand, humidity or liquids, commercial use such as hotel, office, restaurant, or other business or rental use of the product, or service by anyone other than an Authorized Servicer, or damage that is attributable to acts of God.

Dry cell batteries are also excluded from coverage under this warranty.

THIS EXPRESS, LIMITED WARRANTY IS IN LIEU OF ALL OTHER WARRANTIES, EXPRESS OR IMPLIED, INCLUDING ANY IMPLIED WARRANTIES OF MERCHANTABILITY AND FITNESS FOR A PARTICULAR PURPOSE. IN NO EVENT WILL PANASONIC CANADA INC. BE LIABLE FOR ANY SPECIAL, INDIRECT OR CONSEQUENTIAL DAMAGES RESULTING FROM THE USE OF THIS PRODUCT OR ARISING OUT OF ANY BREACH OF ANY EXPRESS OR IMPLIED WARRANTY. (As examples, this warranty excludes damages for lost time, travel to and from the Authorized Servicer, loss of or damage to media or images, data or other memory or recorded content. This list of items is not exhaustive, but for illustration only.)

In certain instances, some jurisdictions do not allow the exclusion or limitation of incidental or consequential damages, or the exclusion of implied warranties, so the above limitations and exclusions may not be applicable. This warranty gives you specific legal rights and you may have other rights which vary depending on your province or territory.

WARRANTY SERVICE

For product operation and information assistance, please contact:

PRODUCT OPERATION ASSISTANCE

Customer Care Centre: Telephone #: 1-800-561-5505
Fax #: (905) 238-2360
Email link: "Support → contact us → email" on www.panasonic.ca

PRODUCT REPAIRS

Please locate your nearest Authorized Servicentre.

Link: "Support → Panasonic Servicentre® locator" on www.panasonic.ca

IF YOU SHIP THE PRODUCT TO A SERVICENTRE

Carefully pack and send prepaid, adequately insured and preferably in the original carton.
Include details of the defect claimed, and proof of date of original purchase.

Reference

-If you see this symbol-

Information on Disposal in other Countries outside the European Union



This symbol is only valid in the European Union. If you wish to discard this product, please contact your local authorities or dealer and ask for the correct method of disposal.



As an ENERGY STAR® Partner,* Panasonic has determined that this product meets the ENERGY STAR® guidelines for energy efficiency.

* For Canada only: The word "Participant" is used in place of the word "Partner".

Panasonic Consumer Marketing
Company of North America,
Division of Panasonic Corporation of
North America
One Panasonic Way, Secaucus,
New Jersey 07094
<http://www.panasonic.com>

Panasonic Canada Inc.
5770 Ambler Drive
Mississauga, Ontario
L4W 2T3
www.panasonic.ca



© Panasonic Corporation 2011
Printed in Malaysia

RQT9660-P
F1211RK0