

# Panasonic®

## Owner's Manual Home Theater Audio System

Model No. SC-HTB370



Thank you for purchasing this product.  
Please read these instructions carefully before using this product,  
and save this manual for future use.

If you have any questions, contact:  
U.S.A. and Puerto Rico: 1-800-211-PANA (7262)  
Canada: 1-800-561-5505

P PC

RQT9777-P

**Confidential** until  
2012/12/27

# IMPORTANT SAFETY INSTRUCTIONS

Read these operating instructions carefully before using the unit. Follow the safety instructions on the unit and the applicable safety instructions listed below. Keep these operating instructions handy for future reference.

- 1 Read these instructions.
- 2 Keep these instructions.
- 3 Heed all warnings.
- 4 Follow all instructions.
- 5 Do not use this apparatus near water.
- 6 Clean only with dry cloth.
- 7 Do not block any ventilation openings. Install in accordance with the manufacturer's instructions.
- 8 Do not install near any heat sources such as radiators, heat registers, stoves, or other apparatus (including amplifiers) that produce heat.
- 9 Do not defeat the safety purpose of the polarized or grounding-type plug. A polarized plug has two blades with one wider than the other.

A grounding-type plug has two blades and a third grounding prong. The wide blade or the third prong are provided for your safety. If the provided plug does not fit into your outlet, consult an electrician for replacement of the obsolete outlet.

- 10 Protect the power cord from being walked on or pinched particularly at plugs, convenience receptacles, and the point where they exit from the apparatus.
- 11 Only use attachments/accessories specified by the manufacturer.
- 12 Use only with the cart, stand, tripod, bracket, or table specified by the manufacturer, or sold with the apparatus. When a cart is used, use caution when moving the cart/apparatus combination to avoid injury from tip-over.
- 13 Unplug this apparatus during lightning storms or when unused for long periods of time.
- 14 Refer all servicing to qualified service personnel. Servicing is required when the apparatus has been damaged in any way, such as power-supply cord or plug is damaged, liquid has been spilled or objects have fallen into the apparatus, the apparatus has been exposed to rain or moisture, does not operate normally, or has been dropped.



## WARNING

### Unit

- To reduce the risk of fire, electric shock or product damage,
  - Do not expose this unit to rain, moisture, dripping or splashing.
  - Do not place objects filled with liquids, such as vases, on this unit.
  - Use only the recommended accessories.
  - Do not remove covers.
- Do not repair this unit by yourself. Refer servicing to qualified service personnel.

### Power cord

- Install this unit so that the power cord can be unplugged from the socket outlet immediately if any problem occurs.

### Button-type battery (Lithium battery)

- Risk of fire, explosion and burns. Do not disassemble, heat above 60 °C (140 °F) or incinerate.



### DO NOT INGEST BATTERY, CHEMICAL BURN HAZARD

This product contains a coin/button cell battery. If the coin/button cell battery is swallowed, it can cause severe internal burns in just 2 hours and can lead to death. Keep new and used batteries away from children. If the battery compartment does not close securely, stop using the product and keep it away from children. If you think batteries might have been swallowed or placed inside any part of the body, seek immediate medical attention.

If any electrolyte should come into contact with your hands or clothes, wash it off thoroughly with water. If any electrolyte should come into contact with your eyes, never rub the eyes. Rinse eyes thoroughly with water, and then consult a doctor.

<For USA-California only>

This product contains a CR Coin Cell Lithium Battery which contains Perchlorate Material – special handling may apply. See [www.dtsc.ca.gov/hazardouswaste/perchlorate](http://www.dtsc.ca.gov/hazardouswaste/perchlorate).

**CAUTION**

**Unit**

- Do not place sources of naked flames, such as lighted candles, on this unit.

**Placement**

- To reduce the risk of fire, electric shock or product damage,
  - Do not install or place this unit in a bookcase, built-in cabinet or in another confined space. Ensure this unit is well ventilated.
  - Do not obstruct this unit's ventilation openings with newspapers, tablecloths, curtains, and similar items.

**Button-type battery (Lithium battery)**

- Danger of explosion if battery is incorrectly replaced. Replace only with the type recommended by the manufacturer.
- Keep out of reach of children.
- Insert with poles aligned.
- Mishandling of batteries can cause electrolyte leakage and may cause a fire.
  - Remove the battery if you do not intend to use the remote control for a long period of time. Store in a cool, dark place.
  - Do not heat or expose to flame.
  - Do not leave the battery(ies) in a car exposed to direct sunlight for a long period of time with doors and windows closed.
  - Do not touch the terminals (+ and -) with metal objects.
  - Do not recharge, disassemble, remodel, heat or throw into fire.
- When disposing the batteries, please contact your local authorities or dealer and ask for the correct method of disposal.

**THE FOLLOWING APPLIES ONLY IN THE U.S.A.**

**FCC Note:**

This equipment has been tested and found to comply with the limits for a Class B digital device, pursuant to Part 15 of the FCC Rules.

These limits are designed to provide reasonable protection against harmful interference in a residential installation. This equipment generates, uses and can radiate radio frequency energy and, if not installed and used in accordance with the instructions, may cause harmful interference to radio communications.

However, there is no guarantee that interference will not occur in a particular installation. If this equipment does cause harmful interference to radio or television reception, which can be determined by turning the equipment off and on, the user is encouraged to try to correct the interference by one or more of the following measures:

- Reorient or relocate the receiving antenna.
- Increase the separation between the equipment and receiver.
- Connect the equipment into an outlet on a circuit different from that to which the receiver is connected.
- Consult the dealer or an experienced radio/TV technician for help.

Any unauthorized changes or modifications to this equipment would void the user's authority to operate this device.

This device complies with Part 15 of the FCC Rules.

Operation is subject to the following two conditions:  
 (1) This device may not cause harmful interference, and  
 (2) this device must accept any interference received, including interference that may cause undesired operation.

Responsible Party:  
 Panasonic Corporation of North America  
 One Panasonic Way,  
 Secaucus, NJ 07094

Support Contact:  
 Panasonic Consumer Marketing Company of  
 North America  
 Telephone No.: 1-800-211-PANA (7262)

**THE FOLLOWING APPLIES ONLY IN CANADA.**



This device complies with RSS-GEN, RSS-210 of the IC Rules. Operation is subject to the following two conditions:

- (1) This device may not cause harmful interference,
- (2) This device must accept any interference received, including interference that may cause undesired operation of the device.

**THE FOLLOWING APPLIES IN THE U.S.A. AND CANADA**

This transmitter must not be co-located or operated in conjunction with any other antenna or transmitter.

This equipment complies with FCC/IC radiation exposure limits set forth for an uncontrolled environment and meets the FCC radio frequency (RF) Exposure Guidelines in Supplement C to OET65 and RSS-102 of the IC radio frequency (RF) Exposure rules. This equipment has very low levels of RF energy that is deemed to comply without maximum permissive exposure evaluation (MPE). But it is desirable that it should be installed and operated keeping the radiator at least 20 cm (7 7/8") or more away from person's body (excluding extremities: hands, wrists, feet and ankles).

	<b>CAUTION</b> RISK OF ELECTRIC SHOCK DO NOT OPEN	
<p>CAUTION: TO REDUCE THE RISK OF ELECTRIC SHOCK, DO NOT REMOVE SCREWS. NO USER-SERVICEABLE PARTS INSIDE.                  REFER SERVICING TO QUALIFIED SERVICE PERSONNEL.</p>		



The lightning flash with arrowhead symbol, within an equilateral triangle, is intended to alert the user to the presence of un-insulated "dangerous voltage" within the product's enclosure that may be of sufficient magnitude to constitute a risk of electric shock to persons.



The exclamation point within an equilateral triangle is intended to alert the user to the presence of important operating and maintenance (servicing) instructions in the literature accompanying the appliance.

# Table of contents

IMPORTANT SAFETY INSTRUCTIONS .....	2
Table of contents .....	4

## Before use

<b>Supplied items</b> .....	<b>5</b>
This unit (SC-HTB370) .....	5
Accessories .....	5
<b>Control reference guide</b> .....	<b>6</b>
This unit (Front) .....	6
This unit (Rear) .....	7
Remote control .....	8

## Getting started

<b>Step 1 Selecting the placement method</b> .....	<b>9</b>
The speaker system .....	10
The active subwoofer .....	10
Wireless interference .....	10
<b>Step 2 Assembling the speakers</b> .....	<b>11</b>
When attaching the speakers to a wall .....	11
When placing the speakers on a table .....	16
Additional speaker fall prevention measures .....	20
<b>Step 3 Connections</b> .....	<b>22</b>
Connection with the TV .....	22
Connection with other devices .....	22
Speaker cable connection .....	23
AC power supply cord connection .....	23
Active subwoofer wireless connection .....	24
Bluetooth® connection .....	24

## Operations

<b>Using this unit</b> .....	<b>25</b>
<b>3D sound</b> .....	<b>26</b>
Audio output modes .....	26
<b>Advanced operations</b> .....	<b>27</b>

## Reference

<b>Troubleshooting</b> .....	<b>29</b>
<b>Specifications</b> .....	<b>30</b>
<b>Unit care</b> .....	<b>32</b>
<b>About Bluetooth®</b> .....	<b>32</b>
<b>Indicator illumination</b> .....	<b>33</b>
<b>Limited Warranty</b>	
(ONLY FOR U.S.A. AND PUERTO RICO) .....	<b>34</b>
<b>Limited Warranty (ONLY FOR CANADA)</b> .....	<b>35</b>

- The illustrations shown may differ from your unit.
- Operations in this Owner's Manual are described mainly with the remote control, but you can perform the operations on the main unit if the controls are the same.





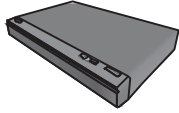
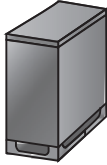
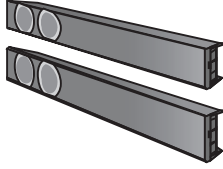



## Supplied items

### This unit (SC-HTB370)

<input type="checkbox"/> <b>1 Main unit</b> (SU-HTB370) 	<input type="checkbox"/> <b>1 Active subwoofer</b> (SB-HWA370) 	<input type="checkbox"/> <b>2 Front speakers</b> (SB-HTB370) 
---	--	--

### Accessories

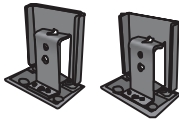
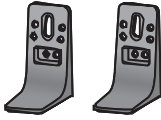
Check the supplied accessories before using this unit.

<input type="checkbox"/> <b>1 Remote control (with a battery)</b> (N2QAYC000083) 	<input type="checkbox"/> <b>2 AC power supply cords</b> (K2CB2Y00084) 	<input type="checkbox"/> <b>2 Speaker cables</b> (REEX1266A: RED) (REEX1267A: WHITE) Length: 3 m (9.8 ft) 	<input type="checkbox"/> <b>1 Metal bracket</b> (RML0760A) 
<input type="checkbox"/> <b>6 Screws</b> (XYN5-J14FJK) 	<input type="checkbox"/> <b>2 Speaker feet</b> (RKAX0042-K) 	<input type="checkbox"/> <b>2 Stand necks</b> (RGK2444) 	<input type="checkbox"/> <b>2 Leg stands</b> (RGK2463) 
<input type="checkbox"/> <b>2 Support legs</b> (RGK2464) 	<input type="checkbox"/> <b>2 Speaker bases</b> (RGK2465) 	<p>(ONLY FOR CANADA) The enclosed French Canadian label sheet corresponds to the English display on the remote control and the top and rear of the main unit and active subwoofer.</p>	



- Product numbers are correct as of December 2012. These may be subject to change.
- For U.S.A. and Puerto Rico:  
To order accessories, refer to "Accessory Purchases (United States and Puerto Rico)" on page 34.  
For Canada: To order accessories, call the dealer from whom you have made your purchase.
- The supplied AC power supply cord is for use with this unit only.  
Do not use it with other equipment. Also, do not use cords from other equipment with this unit.

## Control reference guide

### This unit (Front)

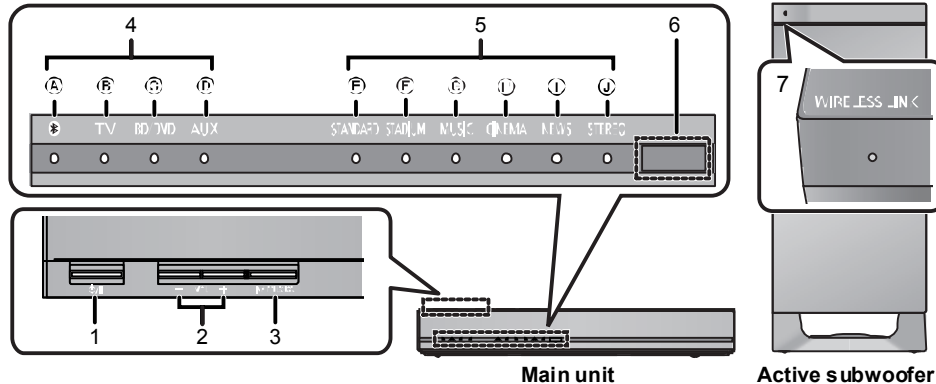

- |  |  |
|--|--|
| <p><b>1 Standby/on switch (⏻/⏻)</b><br/>Press to switch the main unit from on to standby mode or vice versa. In standby mode, the main unit is still consuming a small amount of power.</p> <p><b>2</b> Adjust the volume of this unit</p> <p><b>3</b> Select the input source<br/>"TV" → "BD/DVD" → "AUX"<br/>↑ "⏻" ↓</p> <p><b>4 Input selector indicators*</b></p> <ul style="list-style-type: none"> <li>Ⓐ Bluetooth® indicator<br/>Lights blue when the Bluetooth® device is the audio source</li> <li>Ⓑ TV indicator<br/>Lights green when the TV is the audio source</li> <li>Ⓒ BD/DVD indicator<br/>Lights amber when the device connected to the BD/DVD terminal is the audio source</li> <li>Ⓓ AUX indicator<br/>Lights amber when the device connected to the AUX terminal is the audio source</li> </ul> | <p><b>5 Sound mode indicators*</b></p> <ul style="list-style-type: none"> <li>Ⓔ STANDARD indicator<br/>Lights when STANDARD is the current sound mode</li> <li>Ⓕ STADIUM/Dolby® Digital indicator<br/>Lights when STADIUM is the current sound mode</li> <li>Ⓖ MUSIC/DTS indicator<br/>Lights when MUSIC is the current sound mode</li> <li>Ⓗ CINEMA/PCM indicator<br/>Lights when CINEMA is the current sound mode</li> <li>Ⓘ NEWS indicator<br/>Lights when NEWS is the current sound mode</li> <li>Ⓚ STEREO indicator<br/>Lights when STEREO is the current sound mode</li> </ul> <p><b>6</b> Remote control signal sensor (⇨ 8)</p> <p><b>7</b> WIRELESS LINK indicator (⇨ 24)</p> |
|--|--|

\* The indicators will also blink in various conditions (⇨ 33)  
To indicate the current audio format, refer to page 27 (Audio format indicator)

## This unit (Rear)

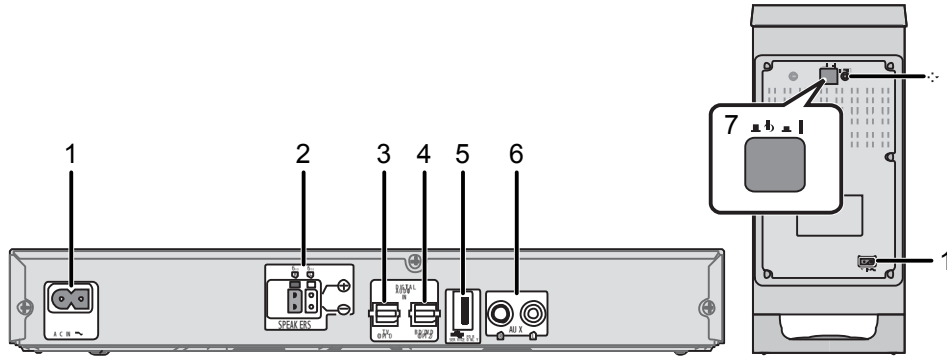

- |                            |                                   |
|----------------------------|-----------------------------------|
| 1 AC IN terminal (⇒ 23)    | 5 USB port (for service use only) |
| 2 Speaker terminals (⇒ 23) | 6 AUX terminal (⇒ 22)             |
| 3 TV terminal (⇒ 22)       | 7 Active subwoofer on/off button  |
| 4 BD/DVD terminal (⇒ 22)   |                                   |

\* The I/D SET button is only used when the main unit is not paired with the active subwoofer (⇒ 30)

## Remote control

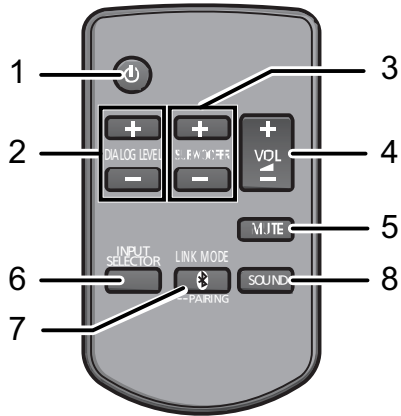

- 1 Turn the main unit on or off (⇒ 25)
- 2 Adjust the dialog effect level (⇒ 25)
- 3 Adjust the output level of the active subwoofer (bass sound) (⇒ 25)
- 4 Adjust the volume of this unit (⇒ 25)
- 5 Mute the sound (⇒ 25)
- 6 Select the input source (⇒ 25)  
 "TV" → "BD/DVD" → "AUX"  
 ↕ "⊗" ↕
- 7 Select the Bluetooth® device as the source (⇒ 25)
- 8 Select the sound mode (⇒ 25)  
 "STANDARD" → "STADIUM" → "MUSIC"  
 ↕ "STEREO" ← "NEWS" ← "CINEMA" ↕

### ■ Before using for the first time

Remove the insulation sheet (A).

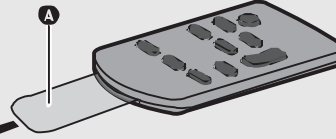

### ■ To replace a button-type battery

Battery type: CR2025 (Lithium battery)

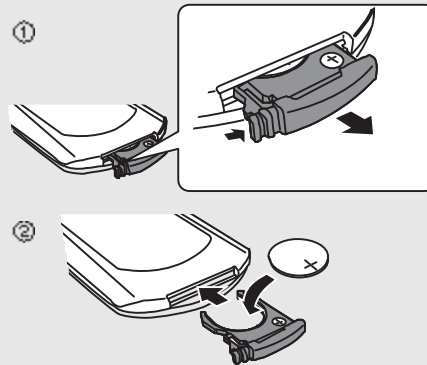

- Set the button-type battery with its (+) mark facing upward.

### ■ Remote control operation range

The remote control signal sensor is located on the main unit.

- Use the remote control within the correct operation range.

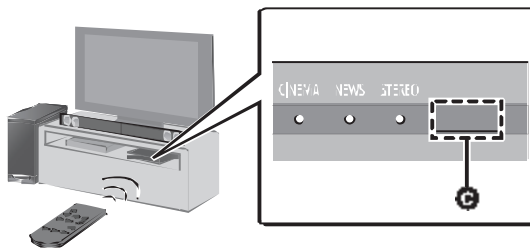

- Remote control signal sensor

#### ● Operation range

- Distance: Within approx. 7 m (23 ft) directly in front
- Angle: Approx. 30° left and right



## Step 1 Selecting the placement method

- Choose a placement method that suits you best.

### When attaching the speakers to a wall

Place the speakers horizontally



Page 11

Place the speakers vertically



Page 14

### When placing the speakers on a table

Place the speakers using the leg stands



Page 16

Place the speakers using the support legs and speaker feet



Page 17

Place the speakers using the speaker bases

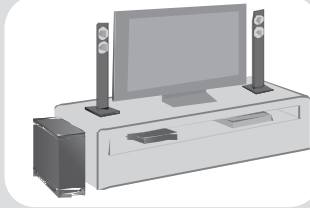

Page 18



### Caution

- This unit is to be used only as indicated in these instructions. Failure to do so may lead to damage to the amplifier and/or the speakers, and may result in the risk of fire. Consult a qualified service person if damage has occurred or if you experience a sudden change in performance.
- Do not attempt to attach these speakers to a wall using methods other than those described in this manual.

## The speaker system

- Use a screwdriver (+) for assembling the speakers.
- Do not hold the speakers in one hand to avoid injury, you may drop the speakers when carrying them.

### ■ When attaching the speakers to a wall

The wall or pillar on which the speakers are to be attached should be capable of supporting 33 kg (72.8 lbs) per screw. Consultation with a qualified installation specialist is recommended when attaching the speakers to a wall. Improper attachment may result in damage to the wall and speakers, and personal injury.

### ■ When placing the speakers in front of the TV

The speakers may block or interfere with the TV's various sensors (C.A.T.S. (Contrast Automatic Tracking System) sensor, remote control sensor, etc.) and the 3D Eyewear transmitters on a 3D compatible TV.

#### ● If the stands are being used

Change the height of the stands and/or move the speakers further away from the TV. If the TV still does not function correctly, try removing the stands.

#### ● If the stands are not used

Move the speakers further away from the TV. If the TV still does not function properly, try placing them beside the TV (→ 9).

## The active subwoofer

### When carrying the active subwoofer

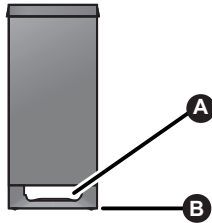

#### ⓐ Do not hold the active subwoofer from this opening.

The parts inside may get damaged.

#### ⓑ Always hold the bottom of the active subwoofer when moving it.

## Wireless interference

To avoid interference, maintain the following distances between the main unit/active subwoofer and other electronic devices that use the same radio frequency (2.4 GHz band).

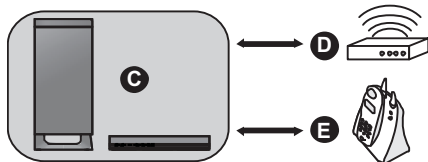

#### Ⓒ Main unit/active subwoofer

#### Ⓓ Wireless LAN: approx. 2 m (6 1/2 ft)

#### Ⓔ Cordless phone and other electronic devices: approx. 2 m (6 1/2 ft)



- Place the active subwoofer within a few meters of the main unit and in a horizontal position with the top panel faced upward.
- Do not use this unit in a metal cabinet.
- Placing the active subwoofer too close to the walls and corners can result in excessive bass. Cover walls and windows with thick curtains.
- If irregular coloring occurs on your TV, turn the TV off for about 30 minutes. If it persists, move the speakers further away from the TV.
- Keep magnetized items away. Magnetized cards, watches, etc., can be damaged if placed too close to the active subwoofer and the speakers.

## Step 2 Assembling the speakers

### When attaching the speakers to a wall



Place the speakers horizontally

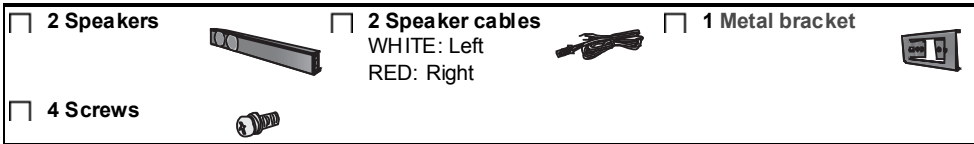

- For a safety measure to prevent the speakers from falling, refer to page 20.
- To prevent damage or scratches, lay down a soft cloth and perform the assembly on it.

#### 1 Assemble the speakers.

- The two speakers are interchangeable.

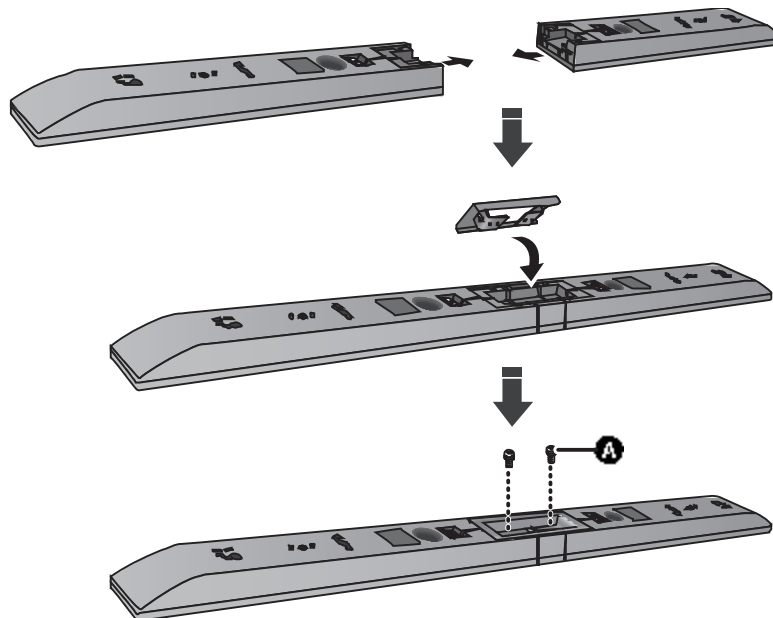

#### A Screw (supplied)

- Be sure to insert the screws following the order as indicated in the illustration.
- Keep the screws out of reach of children to prevent swallowing.

## 2 Connect the speaker cables.

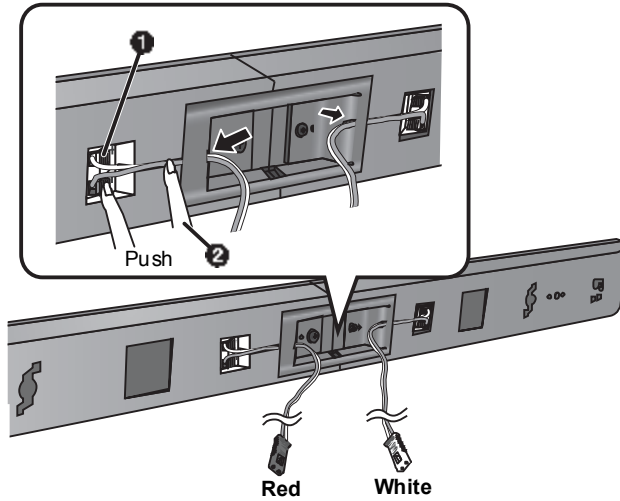

- 1 Insert the wire fully.  
+ : White  
- : Blue line
- 2 Press into the groove.
- A Right speaker connector
- B Left speaker connector

- Insert the wire fully, taking care not to insert beyond the wire insulation.

## 3 Drive a screw into the wall.

- Use the measurements indicated below to identify the screwing positions on the wall.
- Leave at least 20 mm ( $25/32''$ ) of space above and on each side of the speaker to allow enough space for fitting the speaker.
- The position on the wall where the screw is to be attached, as well as the screw, should be capable of supporting over 33 kg (72.8 lbs).
- Keep the screws out of reach of children to prevent swallowing.

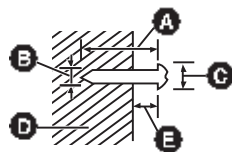

- A At least 30 mm ( $1 \frac{3}{16}''$ )
- B  $\varnothing 4.0$  mm ( $9/32''$ )
- C  $\varnothing 7.0$  mm to  $\varnothing 9.4$  mm ( $9/32''$  to  $3/8''$ )
- D Wall or pillar
- E 5.5 mm to 6.5 mm ( $7/32''$  to  $1/4''$ )

### Front view (semi-transparent image)

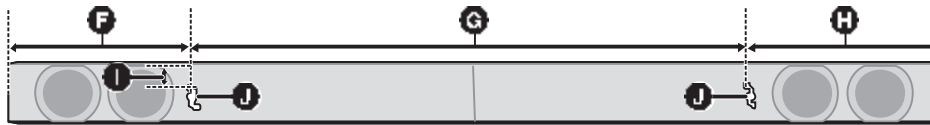

- F 248 mm ( $9 \frac{3}{4}''$ )
- G 745 mm ( $29 \frac{11}{32}''$ )
- H 238 mm ( $9 \frac{3}{8}''$ )
- I 20 mm ( $25/32''$ )
- J Wall mounting hole

**4** Fit the speaker securely onto the screw(s).

**Red connector:** The speaker attached to the red connector cable is to be placed on the **right** side

**White connector:** The speaker attached to the white connector cable is to be placed on the **left** side

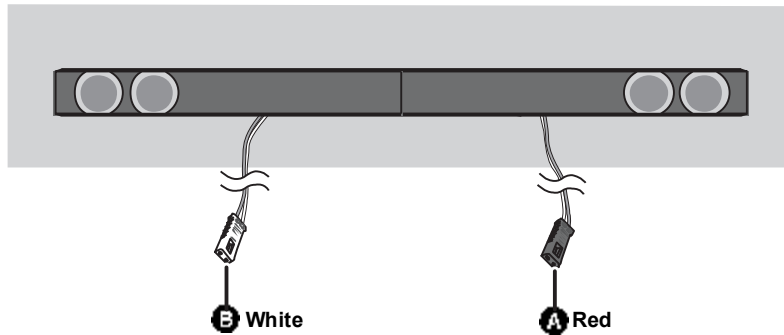
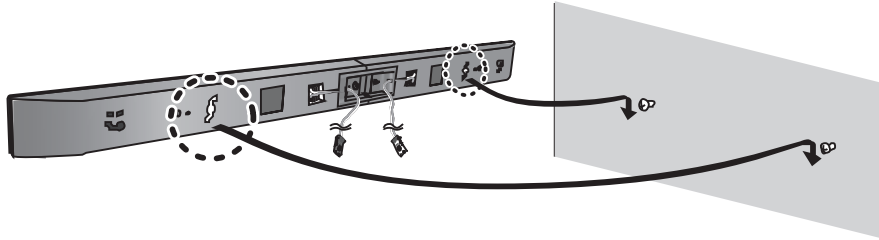

- A** Right speaker connector
- B** Left speaker connector

DO	DO NOT
<ul style="list-style-type: none"> <li>• Move the speaker so that the screw is in this position.</li> </ul>	<ul style="list-style-type: none"> <li>• In this position, the speaker will likely fall if moved to the left or right.</li> </ul>

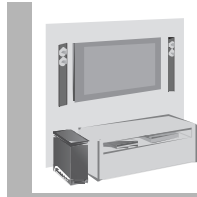

## Place the speakers vertically

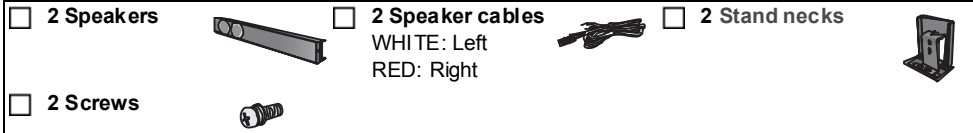

- For a safety measure to prevent the speakers from falling, refer to page 20.
- To prevent damage or scratches, lay down a soft cloth and perform the assembly on it.

### 1 Attach the stand neck.

- The two speakers are interchangeable.
- Keep the screws out of reach of children to prevent swallowing.

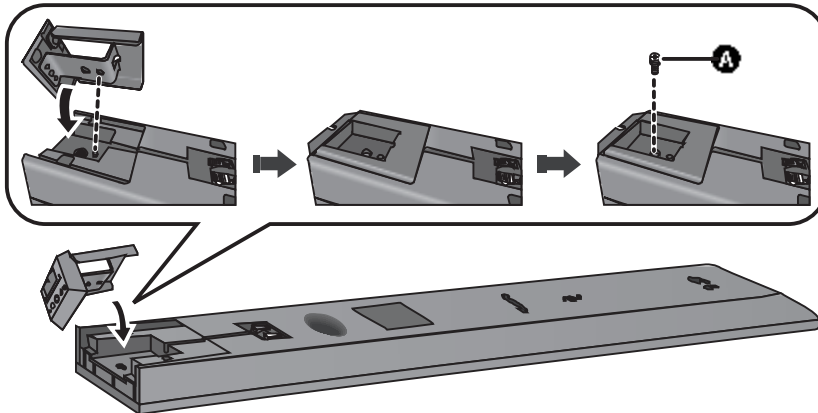

**A** Screw (supplied)

### 2 Connect the speaker cables.

- Insert the wire fully, taking care not to insert beyond the wire insulation.

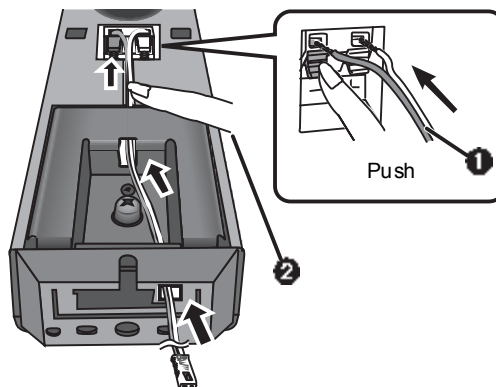

- 1 Insert the wire fully.  
+ : White  
- : Blue line
- 2 Press into the groove.

### 3 Drive a screw into the wall.

- Use the measurements indicated below to identify the screwing positions on the wall.
- Leave at least 20 mm ( $5/32''$ ) of space above and on each side of the speaker to allow enough space for fitting the speaker.
- The position in the wall where the screw is to be attached as well as the screw should be capable of supporting over 33 kg (72.8 lbs).
- Keep the screws out of reach of children to prevent swallowing.

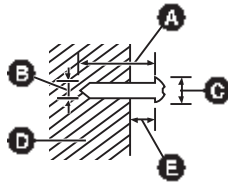

- A At least 30 mm ( $1 \frac{3}{16}''$ )
- B  $\varnothing 4.0$  mm ( $5/32''$ )
- C  $\varnothing 7.0$  mm to  $\varnothing 9.4$  mm ( $9/32''$  to  $3/8''$ )
- D Wall or pillar
- E 5.5 mm to 6.5 mm ( $7/32''$  to  $1/4''$ )

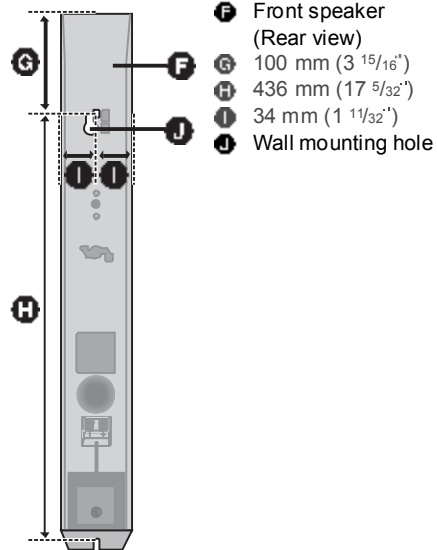

### 4 Fit the speaker(s) securely onto the screw(s).

**Red connector:** The speaker attached to the red connector cable is to be place on the **right** side.  
**White connector:** The speaker attached to the white connector cable is to be place on the **left** side.

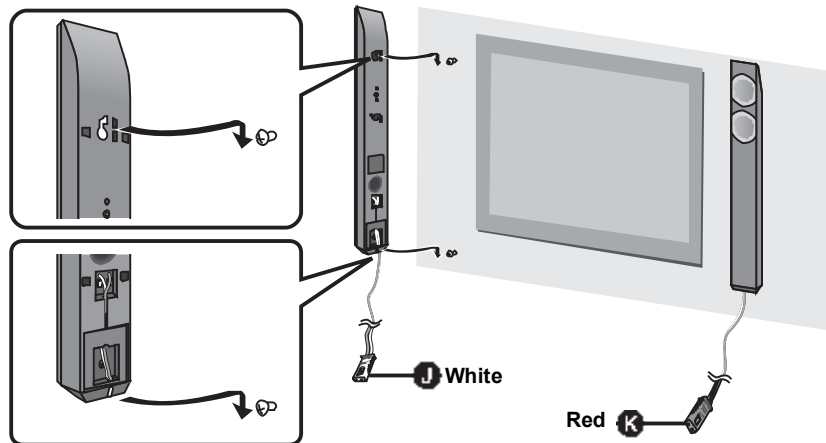

K Left speaker connector

L Right speaker connector

DO	DO NOT
<ul style="list-style-type: none"> <li>Move the speaker so that the screw is in this position.</li> </ul>	<ul style="list-style-type: none"> <li>In this position, the speaker will likely fall if moved to the left or right.</li> </ul>

## When placing the speakers on a table



Place the speakers using the leg stands

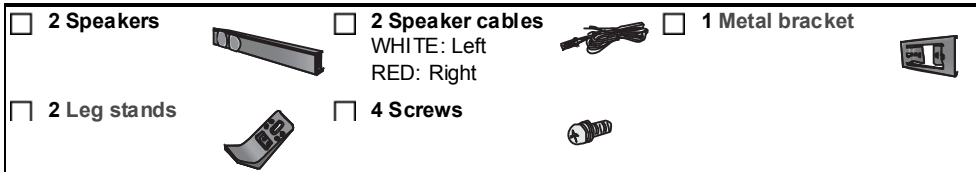

- For a safety measure to prevent the speakers from falling, refer to page 20.
- To prevent damage or scratches, lay down a soft cloth and perform the assembly on it.

**1 Assemble the speakers following steps 1 and 2 of “Place the speakers horizontally” (⇒ 11).**

**2 Attach the leg stands.**

**Red connector:** With the speaker facing down, the speaker attached to the **red** connector cable is to be placed on the **left** side.

**White connector:** With the speaker facing down, the speaker attached to the **white** connector cable is to be placed on the **right** side.

- Keep the screws out of reach of children to prevent swallowing.

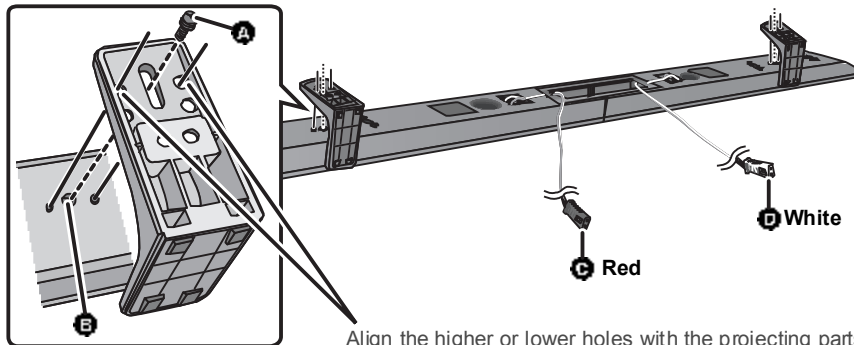

Align the higher or lower holes with the projecting parts on the speaker.

- By changing the position that the stand is attached to the projecting parts, the height can be adjusted by 10 mm ( $13/32$ ”).

- A** Screw (supplied)
- B** Screw hole

- C** Right speaker connector
- D** Left speaker connector



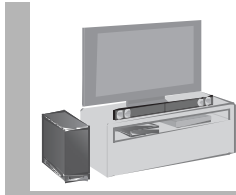

Place the speakers using the support legs and speaker feet

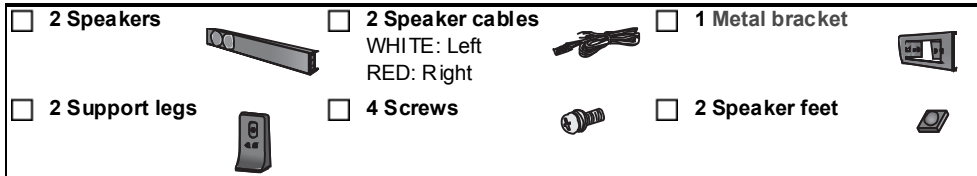

- For a safety measure to prevent the speakers from falling, refer to page 20.
- To prevent damage or scratches, lay down a soft cloth and perform the assembly on it.

**1 Assemble the speakers following steps 1 and 2 of “Place the speakers horizontally” (⇒ 11).**

**2 Attach the support legs and speaker feet.**

**Red connector:** With the speaker facing down, the speaker attached to the red connector cable is to be placed on the left side.

**White connector:** With the speaker facing down, the speaker attached to the white connector cable is to be placed on the right side.

- Keep the screws and the speaker feet out of reach of children to prevent swallowing.

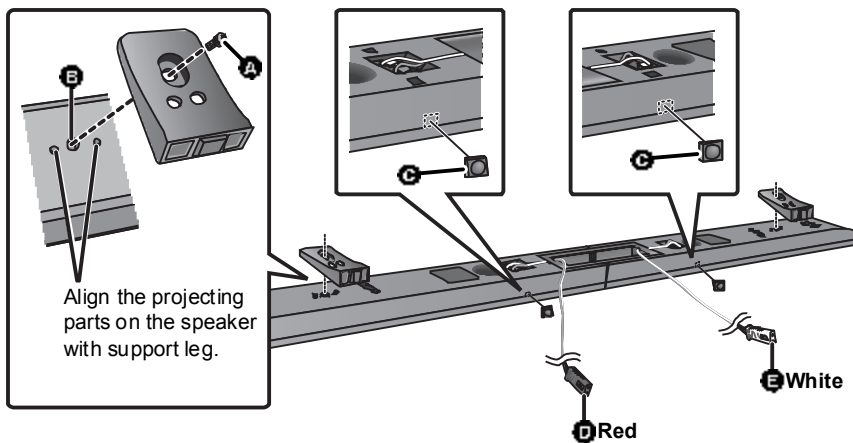

- |                                  |                                  |
|----------------------------------|----------------------------------|
| <b>A</b> Screw (supplied)        | <b>D</b> Right speaker connector |
| <b>B</b> Screw hole              | <b>E</b> Left speaker connector  |
| <b>C</b> Speaker foot (supplied) |                                  |



## Place the speakers using the speaker bases

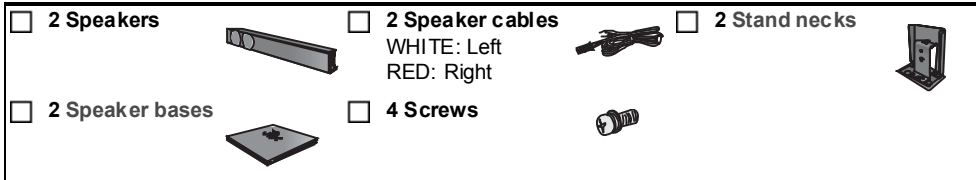

- For a safety measure to prevent the speakers from falling, refer to page 20.
- To prevent damage or scratches, lay down a soft cloth and perform the assembly on it.

**1 Assemble the speakers following step 1 of “Place the speakers vertically” (⇒ 14).**

**2 Insert the speaker cable through the speaker base and connect the speaker cables.**

- Be sure to insert the speaker cable through the threading hole as indicated in the illustration. (If the speaker cable is twisted, it might not fit through the opening. Straighten the speaker cable before inserting.)
- Insert the wire fully, taking care not to insert beyond the wire insulation.

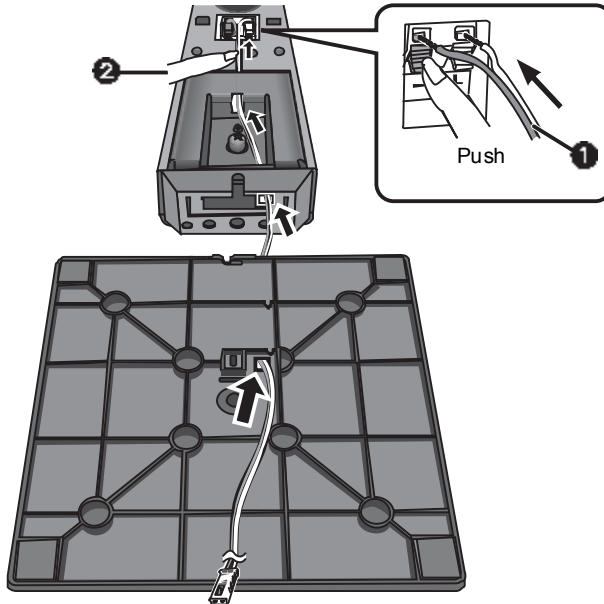

- 1 Insert the wire fully.  
+ : White  
- : Blue line
- 2 Press into the groove.

### 3 Attach the speaker base to the front speaker.

- The two speakers are interchangeable.
- Keep the screws out of reach of children to prevent swallowing.

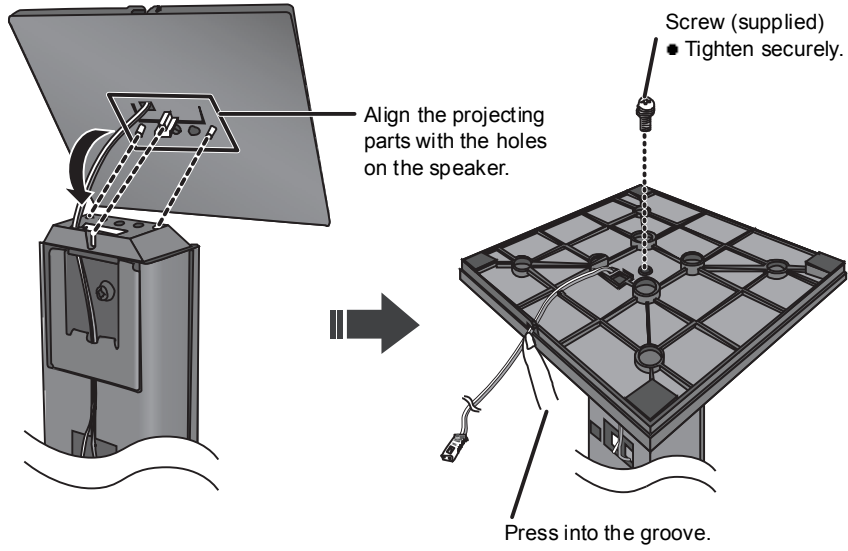

**Red connector:** The speaker attached to the red connector cable is to be placed on the right side.  
**White connector:** The speaker attached to the white connector cable is to be placed on the left side.

### Additional speaker fall prevention measures

To prevent the speakers from falling, it is recommended, as an additional protection measure, to attach the speakers to the wall or table with a fall prevention cord (hereafter “cord”).



- Consultation with a qualified installation specialist concerning the appropriate procedure when attaching to a concrete wall or a surface that may not have strong enough support is recommended (→ 12, 15). Improper attachment may result in damage to the wall and speakers, and personal injury.
- Use a cord that is capable of supporting over 10 kg (22.05 lbs) (with a diameter of about 1.5 mm (1/16”).
- The safety holder is to minimize the possibility of damage and harm, but it does not guarantee this effect.
- Keep the screws out of reach of children to prevent swallowing.
- Make sure that the slack of the cord is minimal.

#### When attaching the speakers to a wall

##### Horizontal placement

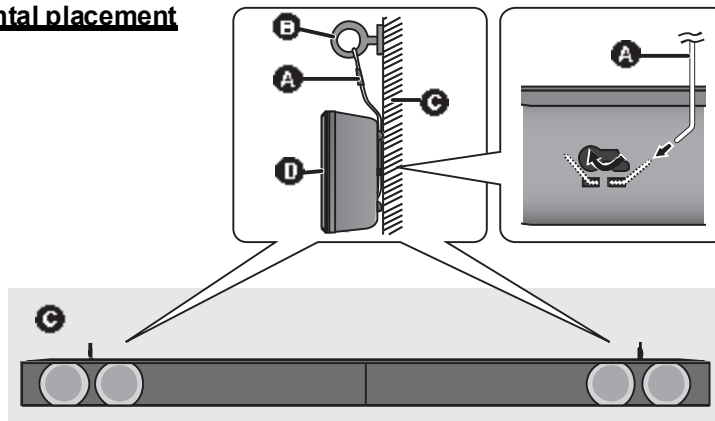

##### Vertical placement

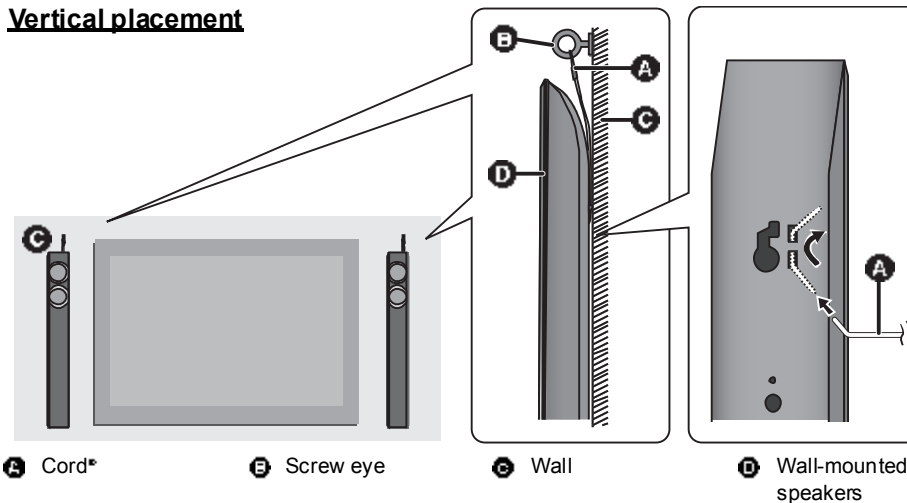

\* If the cord cannot be threaded through the holes, try bending the cord in 2 locations, about 10 mm (13/32”) apart from the tip, at an angle of 45° (as illustrated above).

## When placing the speakers on a table

### Horizontal placement

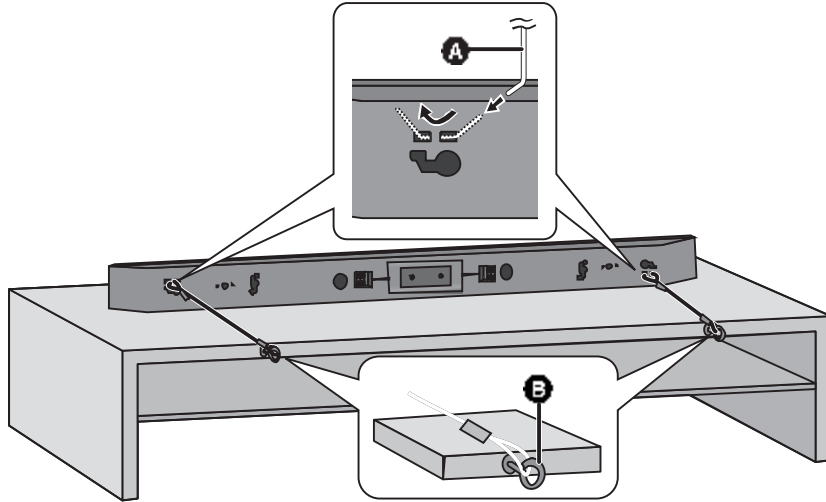

### Vertical placement

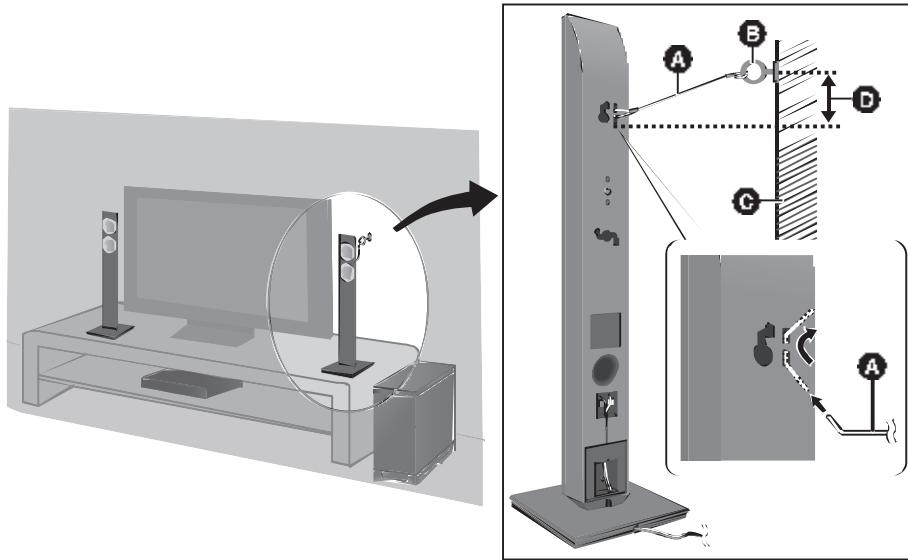

**A** Cord\*

**B** Screw eye

- Depending on the placement of the speakers, the screwing position of the screw eye may differ.

**C** Wall

**D** Approx. 150 mm (5 <sup>29</sup>/<sub>32</sub>" )

\* If the cord cannot be threaded through the holes, try bending the cord in 2 locations, about 10 mm (<sup>13</sup>/<sub>32</sub>" ) apart from the tip, at an angle of 45° (as illustrated above).

## Step 3 Connections

• Turn off all equipment before connection and read the appropriate owner's manual.  
Do not connect the AC power supply cord until all other connections are complete.

### Connection with the TV

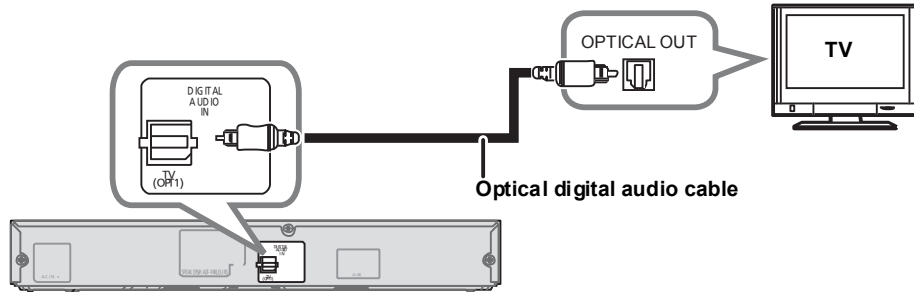

• When you use the optical digital audio cable, insert the tip correctly into the terminal.

### Connection with other devices

You can direct the audio signal from the connected Blu-ray Disc™ player, DVD player, Set Top Box, etc. to this system.

#### High quality audio

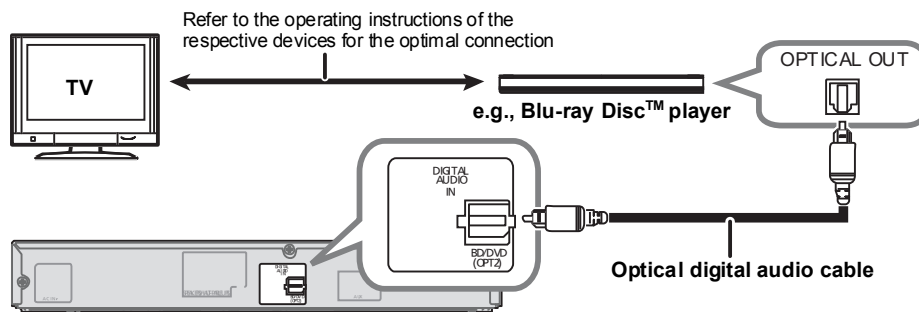

#### Standard quality audio

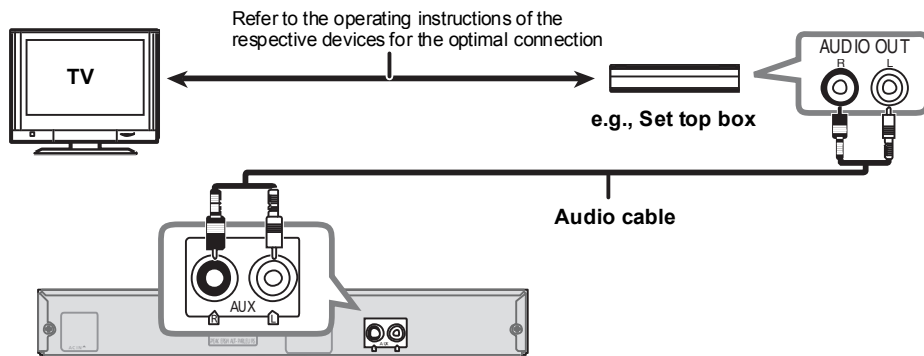

## Speaker cable connection

Match the connector shape and connect to the terminals of the same color.

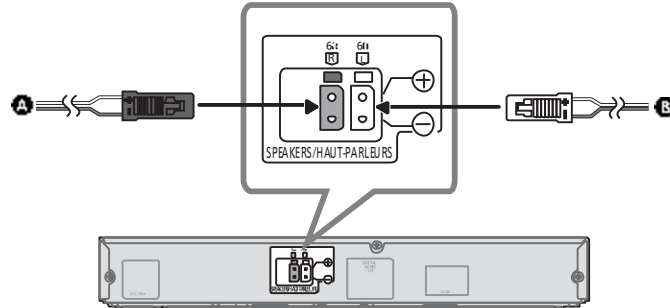

**A RED**  
Right speaker connector

**B WHITE**  
Left speaker connector

## AC power supply cord connection

• Connect only after all other connections are complete.

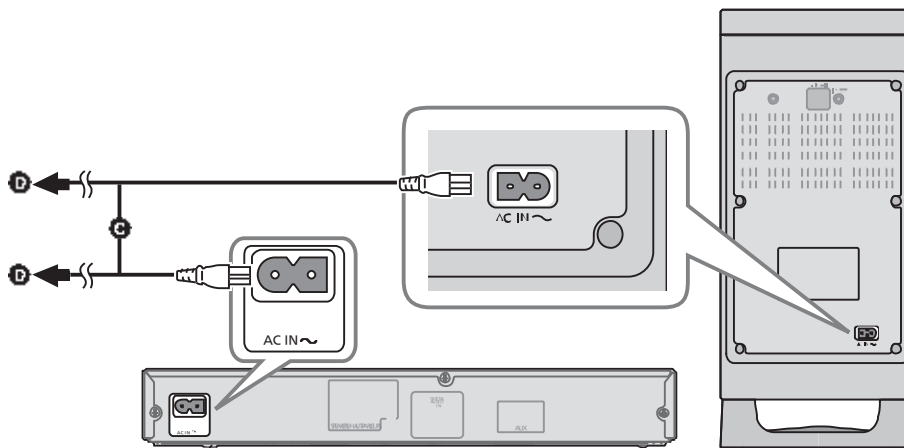

**C AC power supply cord**

**D To a household AC outlet**

• This unit consumes a small amount of AC power (⇒ 30) even when it is turned off. In the interest of power conservation, if you will not be using this unit for a long time, unplug it from the household AC outlet.

### Saving energy

The main unit is designed to conserve its power consumption and save energy.

• **The main unit will automatically switch to standby mode** when no signal is input and no operation is performed for approx. 30 minutes.

## Active subwoofer wireless connection

### Preparation

- Turn on the main unit.

**1** Press [MUTE] [POWER] [MUTE].

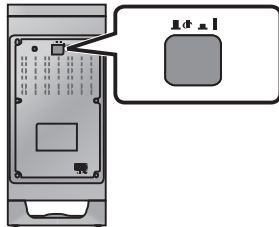

### Active subwoofer on/off button [MUTE] [POWER] [MUTE]

Use this button to turn the active subwoofer on and off.

**MUTE** [POWER] [MUTE]:

The active subwoofer is on

**MUTE** [POWER] [MUTE]:

The active subwoofer is off

The active subwoofer will still consume a small amount of power even when it is turned off (MUTE, POWER)

**2** Check that the wireless link is activated.

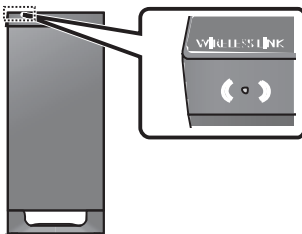

### WIRELESS LINK indicator lights

- **Red:**  
The wireless link is not activated.
- **Green:**  
The wireless link is activated.

## Bluetooth® connection

By using the Bluetooth® connection, you can listen to the sound from the Bluetooth® audio device from this unit wirelessly

### Preparation

- Turn on the Bluetooth® feature of the device and place the device near this unit.

### Pairing a device

**1** Press [PAIRING] – PAIRING].

- “PAIRING” indicator will blink quickly.

**2** Select “SC-HTB370” from the Bluetooth® device’s Bluetooth® menu.

- Once the Bluetooth® device is connected, the “PAIRING” indicator stops flashing and lights up.



Refer to the operating instructions of the Bluetooth® device for further instruction on how to connect a Bluetooth® device. If prompted for the passkey on the Bluetooth® device, enter “0000”.

### Pairing additional devices

**1** Press [PAIRING] – PAIRING].

**2** Press and hold the [PAIRING] – PAIRING] until the “PAIRING” indicator flashes quickly.

**3** Repeat step 2 of “Pairing a device”.



- You can register up to 8 devices with this unit. If a 9th device is paired, the device that has not been used for the longest time will be replaced.
- This unit can only be connected to one device at a time.
- To change the sound quality, refer to “Bluetooth® communication mode” on page 27.



## Using this unit

### Preparation

- Turn on the active subwoofer.
- Turn on the TV and/or connected device.

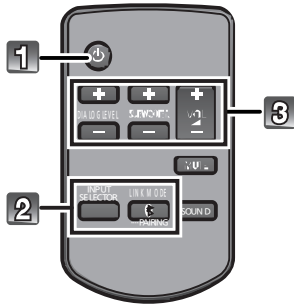

**1** Press [POWER] to turn on the main unit.

**2** Select the source.

Press	To select
[INPUT SELECTOR]	“TV” → “BD/DVD” → “AUX” ← “*” →
[*]	“*” (Bluetooth®)

- This remote control cannot be used to control the operations of the connected devices.

#### ■ When “\*” is selected as the source

On the Bluetooth® device:

Select this unit as the output source of the Bluetooth® device and start the playback.

- Make sure that the Bluetooth® device is already paired with this unit. (→ 24)
- Playback may pause when a different source is selected.

#### ■ When “BD/DVD” is selected as the source

On the connected device:

Select the TV’s input for this unit and start the playback on the connected device.

#### ■ When “AUX” is selected as the source

On the connected device:

Select the TV’s input for the device connected to “AUX” terminal and start the playback on the connected device.

**3** Adjust the volume and sound effect level.

#### ■ To adjust the volume of this unit

Press [+ VOL -].

- Volume range: 1 to 100\*

#### ■ To adjust the dialog effect level

This setting will change the level of the Clear-mode dialog effect. (→ 26)

- 1 Press [+ DIALOG LEVEL -] to display the current level.
- 2 While the level is displayed: Press [+ DIALOG LEVEL -] to adjust the level.\*

Indication	Effect level
	4 Highest
	3 ↑ ↓
	2
	1 Lowest

#### ■ To adjust the subwoofer level

- 1 Press [+ SUBWOOFER -] to display the current level.
- 2 While the level is displayed: Press [+ SUBWOOFER -] to adjust the level.\*

- The level indication pattern is the same as dialog effect level.

#### ■ To mute the sound

Press [MUTE].

- While muting, the sound mode indicators blink simultaneously.
- To cancel, press the button again or adjust the volume.
- Muting is canceled if the main unit is turned off.



**If the main unit does not operate as expected or sound is unusual, return the settings to the factory preset and operate the system again. (→ 29)**

- ※ The sound mode indicators blink from left to right (+) or from right to left (-) while adjusting. The indicators will not blink when it has reached the maximum or minimum.
- If there is sound coming out of the TV’s speakers, reduce the volume of the TV to its minimum.
- If the main unit is turned off with the volume setting in the greater half (above 50), the main unit will automatically lower the volume to the middle (50) when the main unit is turned on (Volume limitation). To turn this function off, refer to page 28.

## 3D sound

This unit provides a feeling that the sound and the image are as one.

- To change the applied effect, refer to "Audio output modes". (⇒ right)

e.g., Image of 3D sound field

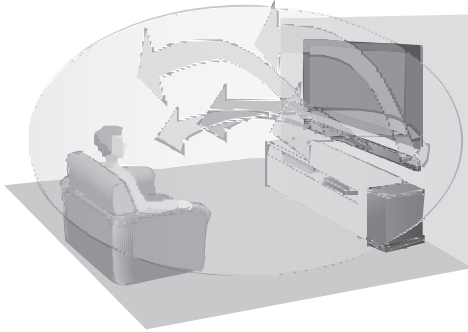

3D sound	
<b>Dolby Virtual Speaker</b>	With this effect you can enjoy a surround sound effect similar to 5.1ch.
<b>3D surround effect</b>	Adding to the Dolby Virtual Speaker effect, Panasonic has applied its own sound field controlling technology to expand the sound field forwards, backwards, upwards, and downwards, providing a sound with depth and force that better matches 3D images.
<b>Clear-mode dialog</b>	Sports commentary and dialogs from TV dramas are heard as if the sound is coming from the TV, giving the feeling that the sound and the image are one. Also, the dialog will stand out from the other sounds during normal volume playback and when the volume is lowered for night time viewing.



- To turn off Dolby Virtual Speaker and the 3D surround effects, select "STEREO" as the audio output mode. (⇒ right)
- To turn off the 3D surround and the Clear-mode dialog effects, refer to "Only using the Dolby Virtual Speaker effect". (⇒ 28)

## Audio output modes

By changing the audio output mode, it is possible to enjoy the sound that is suitable to the TV program or image from the connected device.

### To select the sound mode

Press [SOUND].

"STANDARD" → "STADIUM" → "MUSIC"  
 ↑ "STEREO" ← "NEWS" ← "CINEMA" ↓

- The indicator for the selected sound mode lights. E.g., "STANDARD"



Sound mode	
"STANDARD" (Factory preset)	Produces a sound best suited for dramas and comedy shows.
"STADIUM"	Produces a highly realistic sound for live broadcasts of sports.
"MUSIC"	Re-creates the sound of musical instruments and songs with an expansive sound.
"CINEMA"	Produces a powerful, three-dimensional sound unique to movies.
"NEWS"	Enhances the voices of news and sports commentaries for clearer hearing.
"STEREO"	You can play any source in stereo. Dolby Virtual Speaker and 3D surround effects are turned off.



- The setting is maintained until it is changed again.
- When using the optical digital audio cable, Dolby Virtual Speaker and the 3D surround effect will be temporarily canceled if the audio signal's sampling frequency is greater than 48 kHz.

## Advanced operations

### Audio format indicator

To display the current audio format,

**Press and hold [SOUND] for more than 4 sec.**

- The current audio format is indicated for 5 sec.



"STADIUM" indicator blinks:  
Dolby Digital is the audio format.



"MUSIC" indicator blinks:  
DTS is the audio format.



"CINEMA" indicator blinks:  
PCM or LPCM is the audio format.



- The audio format status is also indicated for 5 sec if the audio format on the selected source (TV, Blu-ray Disc/DVD Player, etc.) is changed.

### Changing the dual audio

Change the dual audio from main to secondary.

- This setting will only work if the audio output setting on the connected TV or player, etc. is set to "Bitstream" and dual audio is available in the audio source.

**1 Press and hold [MUTE] for more than 4 sec.**

**2 While the setting is displayed, press [MUTE] to change the setting.**

- The indicator for the selected setting blinks for 20 sec and then exits the setting mode.



"STANDARD" indicator blinks (A):  
**Main** (Factory preset)



"STEREO" indicator blinks (B):  
**Secondary**  
(SAP: Secondary Audio Program)

(A), (B): Main and secondary

- The setting is maintained until it is changed again.
- The same setting is used for all digital audio sources.

### Auto gain control

With this function, you can prevent sudden loud sounds. The output will be reduced automatically when the input exceeds a certain level.

**1 Press and hold [INPUT SELECTOR] on remote controller for more than 4 sec.**



"STANDARD" indicator blinks:  
**Auto gain control is on.**



"STEREO" indicator blinks:  
**Auto gain control is off.**  
(Factory preset)

**2 While the setting is displayed, press [INPUT SELECTOR] to change the setting.**

- The indicator for the selected setting blinks for 20 sec and then exits the setting mode.
- The setting changes each time [INPUT SELECTOR] is pressed.
- The setting is maintained until it is changed again.
- Default setting of this function is OFF.

### Bluetooth® communication mode

You can select different modes to suit the type of connections which emphasis on connectivity or high quality audio.

- Make sure that a Bluetooth® device is already paired with this unit. (→ 24)

**1 Disable the Bluetooth® connection of the device.**

- "B" indicator will blink slowly.

**2 Press [LINK MODE, B] to display the current mode.**



"STANDARD" indicator blinks:  
**MODE1** (Factory preset)  
Emphasis on connectivity



"STEREO" indicator blinks:  
**MODE2**  
Emphasis on audio quality

**3 While the mode is displayed, press [LINK MODE, B] to select the mode.**

- The setting changes each time [LINK MODE, B] is pressed.
- The indicator for the selected setting blinks for 10 sec and then exits the setting mode.
- The setting is maintained until it is changed again.

### Only using the Dolby Virtual Speaker effect

Depending on your preference, it is possible to turn off the 3D surround effect and the clear-mode dialog effect.

- 1 While pressing and holding [SOUND] on the remote control, press and hold [VOL +] on the main unit for more than 4 sec.

**STANDARD** "STANDARD" indicator blinks:  
3D surround effect and clear-mode dialog effect is on.

**STEREO** "STEREO" indicator blinks:  
3D surround effect and clear-mode dialog effect is off.

- 2 While the setting is displayed, press [SOUND] to change the setting.

- The setting changes each time [SOUND] is pressed.
- The indicator for the selected setting blinks for 20 sec and then exits the setting mode.
- This setting will be reset to on when this unit is turned off.
- When off is selected, the dialog effect level cannot be adjusted.

### Dimmer mode

You can turn off dimmer mode and keep the LED indicators bright.

While pressing and holding [INPUT SELECTOR] on the remote control, press and hold [- VOL] on the main unit to turn off Dimmer mode.

- The indicator for the current condition will turn brighter.
- The setting is maintained until it is changed again.
- Default setting of this function is on.



- To turn on dimmer mode, repeat the operation above. After performing the operation, the indicator for the current condition will be dim.

### Others

#### Remote control code

When other Panasonic devices respond to this unit's remote control, change the remote control code on the main unit and the remote control.

##### Preparation

- Turn off all other Panasonic products.
- Turn on the main unit.

#### Change the remote control code to code 2:

- 1 Aim the remote control at this unit's remote control sensor.
  - 2 Press and hold [MUTE] and [8] on the remote control for more than 4 sec.
- All the indicators will blink for 10 sec when the code of this unit is changed.



- The setting is maintained until it is changed again.



- If this unit does not operate after changing the code, repeat steps 1 and 2.
- To change the remote control code to code 1, repeat the steps above, but replace [8] with [INPUT SELECTOR].

#### To reduce the clear-mode dialog effect

When the dialog does not sound natural while the volume is set low, it is possible to reduce the dialog enhancing effect as follows:

While pressing and holding [SOUND] on the remote control, press and hold [- VOL] on the main unit for more than 2 sec.

- All the indicators will blink once when the clear-mode dialog effect is reduced.



- Even if clear-mode dialog effect is reduced, dialog effect level is still adjustable.



To reset the setting, return to the factory preset. (↔ 29)

#### To turn off the volume limitation

If a state of the lowered volume disturbs you every time this unit turns on, for example, it is possible to turn off this function as follows:

While pressing and holding [MUTE] on the remote control, press and hold [VOL +] on the main unit for more than 2 sec.

- All the indicators will blink once when the volume limitation is turned off.



To reset the setting, return to the factory preset. (↔ right)

## Troubleshooting

Before requesting service, make the following checks. If you are in doubt about some of the check points, or if the solutions indicated in the following guide do not solve the problem, refer to "Customer Services Directory (United States and Puerto Rico)" on page 34 if you reside in the U.S.A. or Puerto Rico, or refer to "WARRANTY SERVICE" on page 35 if you reside in Canada.

### To return to the factory preset.

While the main unit is on, press **[P/I]** on the main unit for more than 4 sec.  
(All the indicators will blink twice when the main unit is reset.)

### If this unit does not operate as expected, returning the settings to the factory preset may solve the problem.

- The remote control code will return to "1" when the main unit is returned to the factory preset. To change the remote control code, refer to page 28.

## General operation

### No power.

- Insert the AC power supply cord securely. (⇒ 23)
- After turning the main unit on, if the indicators blink and the main unit immediately turns off, unplug the AC power supply cord and consult your dealer.

### The remote control does not work properly.

- The battery is depleted. Replace it with a new one. (⇒ 8)
- It is possible that the insulation sheet has not been removed. Remove the insulation sheet. (⇒ 8)
- It may be necessary to set the code of the remote control again after changing the battery of the remote control. (⇒ 28)
- Use the remote control within the correct operation range. (⇒ 8)

### The "TV" indicator blinks.

Remove the AC power supply cord and consult your dealer. If there are any other indicators blinking, be sure to inform your dealer about the blinking indicators.

### The main unit is automatically switched to standby mode.

The main unit will automatically switch to standby mode when no signal is input and no operation is performed for approx. 30 minutes. (⇒ 23)

## Bluetooth®

### Pairing cannot be done.

Check the Bluetooth® device condition.

### The device cannot be connected.

- The pairing of the device was unsuccessful. Try pairing the device again.
- The pairing of the device has been replaced. Pair the device again. (⇒ 24)
- This unit might be connected to a different device. Disconnect the other device and try pairing the device again.

### The device is connected but audio cannot be heard through this unit.

For some built-in Bluetooth® devices, you have to set the audio output to "SC-HTB370" manually. Read the operating instructions for the device for details.

### Sound from the device is uneven.

- The device is out of the 10 m (33 ft) communication range. Bring the device closer to the main unit.
- Remove any obstacle between the main unit and the device.
- Switch off any wireless LAN device.
- Select "MODE1" for stable communication. (⇒ 27)

## Sound

### No sound (or image).

- Turn muting off. (⇒ 25)
- Check the connections to the other devices. (⇒ 22)
- Make sure that the received audio signal is compatible with this unit. (⇒ 30)
- Turn this unit off and then on again.
- If the connections are correct, there might be a problem with the cables. Redo the connections with different cables.
- Check the audio output settings on the connected device.

### The dual audio cannot be changed from main to secondary.

If the audio received from the connected device is not "Dolby Dual Mono" or the output setting is not "Bitstream", the setting cannot be changed from this unit. Change the setting on the connected device.

### The volume is lowered when this unit is turned on.

If the main unit is turned off with the volume setting in the greater half (above 50), the main unit will automatically lower the volume to the middle (50) when the main unit is turned on. (⇒ 28)

### The dialog is too persistent or the dialog does not sound natural.

This unit has a function to make the dialog stand out when the volume is low. (⇒ 28)

**There is no audio.**

**The power of the main unit turns off automatically.**

(When the main unit detects a problem, a safety measure is activated and the main unit automatically switches to standby mode.)

- There is a problem with the amplifier.
- Is the volume extremely high?  
If so, lower the volume.
- Is this unit placed in an extremely hot place?  
If so, move this unit to a cooler place and wait a few moments and then try to turn it on again.

If the problem persists, confirm the TV indicator and BD/DVD indicator blink, turn this unit off, remove the AC power supply cord and consult your dealer. Please be sure to remember the indicators that were blinking and inform the dealer.

**Active Subwoofer**

**No power.**

Ensure the AC power supply cord of the active subwoofer is connected properly.

**After turning the subwoofer on, it immediately turns off.**

Unplug the AC power supply cord and consult your dealer.

**No sound from the subwoofer.**

- Check that the active subwoofer is turned on.
- Check that the wireless link indicator lights green. (⇒ 24)

**The wireless link indicator lights red.**

- There is no link between this unit and the active subwoofer.
  - Check that this unit is turned on.
  - Turn the active subwoofer off and then back on. Alternatively, turn the active subwoofer off, disconnect the AC power supply cord and then reconnect it.
- The active subwoofer and the main unit may not be paired correctly. Try the following operation. (Wireless pairing)
  - ① Turn on the main unit and active subwoofer.
  - ② Press [ID SET] on the rear of the active subwoofer. (The WIRELESS LINK indicator will light red and green alternately.)
  - ③ While pressing and holding [INPUT SELECTOR] on remote control, press and hold [VOL +] on the main unit for more than 4 sec. (The BD/DVD indicator will blink and sound mode indicators light up in sequence.)
    - When the wireless pairing is successful, BD/DVD indicator will stop flashing and WIRELESS LINK indicator lights green.
  - ④ Turn the main unit off and on.
- Consult your dealer if the problem persists.

**Specifications**

**AMPLIFIER SECTION**

**RMS output power**

**10 % total harmonic distortion**

**Subwoofer ch** 120 W per channel (100 Hz, 8 Ω)

**Front ch (L, R ch)** 60 W per channel (1 kHz, 6 Ω)

**Total RMS Dolby Digital mode power** 300 W

**FTC output power**

**1.0 % total harmonic distortion**

**Subwoofer ch** 60 Hz to 120 Hz 40 W (8 Ω)

**Front ch (L, R ch)** 120 Hz to 20 kHz 25 W (6 Ω)

**Total FTC Dolby Digital mode power** 115 W

**WIRELESS SECTION**

**Wireless module**

**Frequency Range** 2.4 GHz band

**Number of channels** 3

**TERMINAL SECTION**

**Digital audio input**

**Optical digital input (TV, BD/DVD)** 2

**Sampling frequency**

32 kHz, 44.1 kHz, 48 kHz  
88.2 kHz, 96 kHz (only LPCM)

**Audio format**

LPCM, Dolby Digital, DTS

**SPEAKER SECTION**

**Front speakers**

**2 way, 2 speaker system (Bass reflex type)**

**Speaker unit(s)** Impedance 6 Ω

**Woofers** 6.5 cm (2 1/2") cone type×1

**Tweeter** 2.5 cm (1") semi-dome type×1

**Frequency range** 100 Hz to 30 kHz (−16 dB)  
150 Hz to 25 kHz (−10 dB)

**Active subwoofer**

**1 way, 1 speaker system (Bass reflex type)**

**Woofers** 16 cm (6 1/2") cone type×1

**Frequency range** 30 Hz to 180 Hz (−16 dB)  
35 Hz to 160 Hz (−10 dB)

## GENERAL

<b>Power consumption</b>	Main unit: 22 W Active subwoofer: 20 W
<b>In standby condition</b>	
Main unit (When the other connected devices are turned off)	Approx. 0.25 W
Active subwoofer:	Approx. 0.2 W
<b>Power supply</b>	AC 120 V, 60 Hz
<b>Dimensions (W×H×D)</b>	
<b>Main unit</b>	
<b>Cabinet dimension</b>	310 mm×44 mm×195 mm (12 7/32"×1 23/32"×7 11/16")
<b>Maximum outer dimension</b>	310 mm×45 mm×202 mm (12 7/32"×1 25/32"×7 15/16")
<b>Active subwoofer</b>	180 mm×408 mm×306 mm (7 3/32"×16 1/16"×12 1/16")
<b>Mass (Weight)</b>	
<b>Main unit</b>	1.1 kg (2.4 lbs)
<b>Active subwoofer</b>	5.2 kg (11.47 lbs)
<b>Operating temperature range</b>	0 °C to +40 °C (+32 °F to +104 °F)
<b>Operating humidity range</b>	20 % to 80 % RH (no condensation)

## SPEAKER GENERAL

<b>Horizontal placement using the stands</b>	
<b>Dimensions (W×H×D)</b>	956 mm×102 mm×74 mm (37 5/8"×4 1/32"×2 29/32")
<b>Mass (Weight)</b>	1.61 kg (3.7 lbs)
<b>Horizontal placement using the speaker feet and the support legs</b>	
<b>Dimensions (W×H×D)</b>	956 mm×78 mm×55 mm (37 5/8"×3 1/16"×2 5/32")
<b>Mass (Weight)</b>	1.57 kg (3.5 lbs)
<b>Horizontal placement (for wall mount)</b>	
<b>Dimensions (W×H×D)</b>	956 mm×75 mm×35 mm (37 5/8"×2 15/16"×1 3/8")
<b>Mass (Weight)</b>	1.54 kg (3.5 lbs)
<b>Vertical placement using the speaker bases</b>	
<b>Dimensions (W×H×D)</b>	148 mm×528 mm×145 mm (5 13/16"×20 25/32"×5 23/32")
<b>Mass (Weight)</b>	0.88 kg (1.98 lbs)
<b>Vertical placement (for wall mount)</b>	
<b>Dimensions (W×H×D)</b>	75 mm×478 mm×35 mm (2 15/16"×18 13/16"×1 3/8")
<b>Mass (Weight)</b>	0.77 kg (1.76 lbs)

## Bluetooth® SECTION

<b>Bluetooth® system specification</b>	V3.0
<b>Wireless equipment classification</b>	Class 2 (2.5 mW)
<b>Supported profiles</b>	A2DP, AVRCP
<b>Frequency band</b>	2.4 GHz band (Adaptive Frequency Hopping)
<b>Operating distance</b>	10 m (33 ft) Line of Sight



- 1 Specifications are subject to change without notice.
- 2 Weight and dimensions are approximate.
- 3 Total harmonic distortion is measured by a digital spectrum analyzer.

## Unit care

### ■ Clean this unit with a soft, dry cloth

- When dirt is heavy, wring a cloth moistened in water tightly to wipe the dirt, and then wipe it with a dry cloth.
- When cleaning this unit, use a fine cloth. Do not use tissues or other materials (towels, etc.) that can fall apart. Small grains may get stuck inside the speaker cover.
- Never use alcohol, paint thinner or benzine to clean this unit.
- Before using chemically-treated cloth, carefully read the instructions that came with the cloth.

Manufactured under license from Dolby Laboratories. Dolby, Pro Logic, and the double-D symbol are trademarks of Dolby Laboratories.

Manufactured under license under U.S. Patent Nos: 5,956,674; 5,974,380; 6,487,535 & other U.S. and worldwide patents issued & pending.  
DTS, the Symbol, & DTS and the Symbol together are registered trademarks & DTS Digital Surround and the DTS logos are trademarks of DTS, Inc. Product includes software.  
© DTS, Inc. All Rights Reserved.

The Bluetooth® word mark and logos are owned by the Bluetooth SIG, Inc. and any use of such marks by Panasonic Corporation is under license. Other trademarks and trade names are those of their respective owners.

## About Bluetooth®

**Panasonic bears no responsibility for data and/or information that is compromised during a wireless transmission.**

### ■ Frequency band used

This unit uses the 2.4 GHz frequency band.

### ■ Certification of this device

- This unit conforms to frequency restrictions and has received certification based on frequency laws. Thus, a wireless permit is not necessary.
- The action below are punishable by law in some countries:
  - Taking apart or modifying the unit.
  - Removing specification indications.

### ■ Restrictions of use

- Wireless transmission and/or usage with all Bluetooth® equipped devices is not guaranteed.
- All devices must conform to standards set by Bluetooth SIG, Inc.
- Depending on the specifications and settings of a device, it can fail to connect or some operations can be different.
- This unit supports Bluetooth® security features. But depending on the operating environment and/or settings, this security is possibly not sufficient. Transmit data wirelessly to this unit with caution.
- This unit cannot transmit data to a Bluetooth® device.

### ■ Range of use

Use this device at a maximum range of 10 m (33 ft). The range can decrease depending on the environment, obstacles or interference.

### ■ Interference from other devices

- When other devices use the same frequency as this unit, this unit may operate incorrectly or the sound may be distorted.
- To prevent interference from other devices:
  - Keep this unit away from other devices that emit radio frequency interference.
  - Do not use this system and a wireless LAN device at the same time. Switch off any wireless LAN device.









### ■ Intended usage

- This unit is for normal, general use only.
- Do not use this unit near an equipment or in an environment that is sensitive to radio frequency interference (example: airports, hospitals, laboratories, etc).

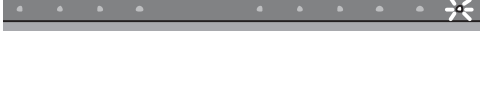

## Indicator illumination

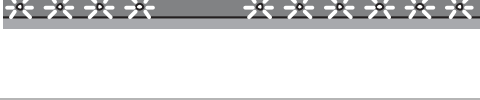
The indicators display the condition of this unit by flashing. The indicator patterns illustrated below are displayed during normal operational conditions. They do not refer to the indications of a problem. Refer to "Troubleshooting" (⇒ 29) if the indicators do not light up as illustrated below.

Indicator	Description
	<p><b>The BD/DVD indicator blinks*2 and sound mode indicators light up in sequence for 1 minute.</b></p> <ul style="list-style-type: none"> <li>When the main unit is in wireless pairing mode with the active subwoofer (⇒ 30)</li> </ul>
	<p><b>The indicator blinks for 20 sec.</b></p> <ul style="list-style-type: none"> <li>When 3D surround effect and clear-mode dialog effect are on (⇒ 28)</li> <li>When the dual audio setting is Main (⇒ 27)</li> <li>When the auto gain control is on (⇒ 27)</li> <li>When the Bluetooth® communication is mode 1 (⇒ 27)</li> </ul>
	<p><b>The indicators blink for 5 sec.</b></p> <ul style="list-style-type: none"> <li>When the audio format is Dolby Digital (⇒ 27)</li> </ul>
	<p><b>The indicator blinks for 5 sec.</b></p> <ul style="list-style-type: none"> <li>When the audio format is DTS (⇒ 27)</li> </ul>
	<p><b>The indicators blink for 5 sec.</b></p> <ul style="list-style-type: none"> <li>When the audio format is PCM (⇒ 27)</li> </ul>
	<p><b>The indicator blinks for 20 sec.</b></p> <ul style="list-style-type: none"> <li>When 3D surround effect and clear-mode dialog effect are off (⇒ 28)</li> <li>When the dual audio setting is Secondary (SAP: Secondary Audio Program) (⇒ 27)</li> <li>When the auto gain control is off (⇒ 27)</li> <li>When the Bluetooth® communication is mode 2 (⇒ 27)</li> </ul>
	<p><b>The indicators blink for 20 sec.</b></p> <ul style="list-style-type: none"> <li>When the dual audio setting is Main and Secondary (⇒ 27)</li> </ul>
	<p><b>The indicators blink for 10 sec.</b></p> <ul style="list-style-type: none"> <li>When the remote control code is changed (⇒ 28)</li> </ul> <p><b>The indicators blink once.</b></p> <ul style="list-style-type: none"> <li>When changing the setting ("To reduce the clear-mode dialog effect", and "To turn off the volume limitation") (⇒ 28)</li> </ul>
	<p><b>Bluetooth® indicator blinks quickly.</b></p> <ul style="list-style-type: none"> <li>When the main unit is ready for pairing</li> </ul> <p><b>Bluetooth® indicator blinks slowly.</b></p> <ul style="list-style-type: none"> <li>When the main unit is waiting to connect</li> </ul> <p><b>Bluetooth® indicator turns on.</b></p> <ul style="list-style-type: none"> <li>When the main unit is connected with a Bluetooth® device</li> </ul>

\*1 The selected source indicator will also light.

\*2 The BD/DVD indicator stops blinking and lights once the wireless pairing is successful.

# Limited Warranty (ONLY FOR U.S.A. AND PUERTO RICO)

Panasonic Consumer Marketing Company of North America,  
Division of Panasonic Corporation of North America  
One Panasonic Way, Secaucus, New Jersey 07094

## Panasonic Products Limited Warranty

### Limited Warranty Coverage (For USA and Puerto Rico Only)

If your product does not work properly because of a defect in materials or workmanship, Panasonic Consumer Marketing Company of North America (referred to as "the warrantor") will, for the length of the period indicated on the chart below, which starts with the date of original purchase ("warranty period"), at its option either (a) repair your product with new or refurbished parts, (b) replace it with a new or a refurbished equivalent value product, or (c) refund your purchase price. The decision to repair, replace or refund will be made by the warrantor.

Product or Part Name	Parts	Labor
Home Theater Audio System	1 year	1 year
All included Accessories (Except Non-Rechargeable Batteries)	90 days	Not Applicable
Only Non-Rechargeable Batteries	10 days	Not Applicable

During the "Labor" warranty period there will be no charge for labor. During the "Parts" warranty period, there will be no charge for parts. This Limited Warranty excludes both parts and labor for non-rechargeable batteries, antennas, and cosmetic parts (cabinet). This warranty only applies to products purchased and serviced in the United States or Puerto Rico. This warranty is extended only to the original purchaser of a new product which was not sold "as is".

### Mail-In Service

For assistance in the U.S.A. and Puerto Rico in obtaining repairs, please ship the product prepaid to:

Panasonic Exchange Center  
4900 George McVay Drive  
Suite B  
McAllen, TX 78503  
[panacare@us.panasonic.com](mailto:panacare@us.panasonic.com)

### Online Repair Request

To submit a new repair request and for quick repair status visit our Web Site at [www.panasonic.com/repair](http://www.panasonic.com/repair).

When shipping the unit, carefully pack, include all supplied accessories listed in the Owner's Manual, and send it prepaid, adequately insured and packed well in a carton box. When shipping Lithium Ion batteries please visit our Web Site at [www.panasonic.com/BatteryHandling](http://www.panasonic.com/BatteryHandling) as Panasonic is committed to providing the most up to date information. Include a letter detailing the complaint, a return address and provide a daytime phone number where you can be reached. A valid registered receipt is required under the Limited Warranty.

**IF REPAIR IS NEEDED DURING THE WARRANTY PERIOD, THE PURCHASER WILL BE REQUIRED TO FURNISH A SALES RECEIPT/ PROOF OF PURCHASE INDICATING DATE OF PURCHASE, AMOUNT PAID AND PLACE OF PURCHASE. CUSTOMER WILL BE CHARGED FOR THE REPAIR OF ANY UNIT RECEIVED WITHOUT SUCH PROOF OF PURCHASE.**

### Limited Warranty Limits And Exclusions

This warranty ONLY COVERS failures due to defects in materials or workmanship, and DOES NOT COVER normal wear and tear or cosmetic damage. The warranty ALSO DOES NOT COVER damages which occurred in shipment, or failures which are caused by products not supplied by the warrantor, or failures which result from accidents, misuse, abuse, neglect, mishandling, misapplication, alteration, faulty installation,

set-up adjustments, misadjustment of consumer controls, improper maintenance, power line surge, lightning damage, modification, introduction of sand, humidity or liquids, commercial use such as hotel, office, restaurant, or other business or rental use of the product, or service by anyone other than a Factory Service Center or other Authorized Servicer, or damage that is attributable to acts of God.

**THERE ARE NO EXPRESS WARRANTIES EXCEPT AS LISTED UNDER "LIMITED WARRANTY COVERAGE". THE WARRANTOR IS NOT LIABLE FOR INCIDENTAL OR CONSEQUENTIAL DAMAGES RESULTING FROM THE USE OF THIS PRODUCT, OR ARISING OUT OF ANY BREACH OF THIS WARRANTY.**

(As examples, this excludes damages for lost time, travel to and from the servicer, loss of or damage to media or images, data or other memory or recorded content. The items listed are not exclusive, but for illustration only.) **ALL EXPRESS AND IMPLIED WARRANTIES, INCLUDING THE WARRANTY OF MERCHANTABILITY, ARE LIMITED TO THE PERIOD OF THE LIMITED WARRANTY.**

Some states do not allow the exclusion or limitation of incidental or consequential damages, or limitations on how long an implied warranty lasts, so the exclusions may not apply to you. This warranty gives you specific legal rights and you may also have other rights which vary from state to state. If a problem with this product develops during or after the warranty period, you may contact your dealer or Service Center. If the problem is not handled to your satisfaction, then write to the warrantor's Consumer Affairs Department at the addresses listed for the warrantor.

**PARTS AND SERVICE, WHICH ARE NOT COVERED BY THIS LIMITED WARRANTY, ARE YOUR RESPONSIBILITY.**

### Customer Services Directory (United States and Puerto Rico)

Obtain Product Information and Operating Assistance; locate your nearest Dealer or Service Center; purchase Parts and Accessories; or make Customer Service and Literature requests by visiting our Web Site at: <http://www.panasonic.com/help> or, contact us via the web at: <http://www.panasonic.com/contactinfo>. You may also contact us directly at: 1-800-211-PANA (7262) Monday-Friday 9am-9pm, Saturday-Sunday 10am-7pm EST

**For hearing or speech impaired TTY users, TTY: 1-877-833-8855**

### Accessory Purchases (United States and Puerto Rico)

Purchase Parts, Accessories and Instruction Books online for all Panasonic Products by visiting our Web Site at: <http://www.pstc.panasonic.com> Or, send your request by E-mail to: [ppcparts@us.panasonic.com](mailto:ppcparts@us.panasonic.com). You may also contact us directly at: 1-800-332-5368 (Phone) 1-800-237-9080 (Fax Only) (Monday-Friday 9am-9pm EST) Panasonic National Parts Center 20421 84th Ave S., Kent, WA 98032 (We accept Visa, MasterCard, Discover Card, American Express)

**For hearing or speech impaired TTY users, TTY: 1-866-605-1277**

As of October 2012

The model number and serial number of this product can be found on either the back or the bottom of the unit. Please note them in the space provided below and keep for future reference.

MODEL NUMBER SC-HTB370

SERIAL NUMBER \_\_\_\_\_

User memo:

DATE OF PURCHASE \_\_\_\_\_

DEALER NAME \_\_\_\_\_

DEALER ADDRESS \_\_\_\_\_

TELEPHONE NUMBER \_\_\_\_\_

## Limited Warranty (ONLY FOR CANADA)

Panasonic Canada Inc.  
5770 Ambler Drive, Mississauga, Ontario L4W 2T3

### PANASONIC PRODUCT - LIMITED WARRANTY

Panasonic Canada Inc. warrants this product to be free from defects in material and workmanship under normal use and for a period as stated below from the date of original purchase agrees to, at its option either (a) repair your product with new or refurbished parts, (b) replace it with a new or a refurbished equivalent value product, or (c) refund your purchase price. The decision to repair, replace or refund will be made by Panasonic Canada Inc.

**Technics Audio Product - One (1) year, parts and labour**  
**Panasonic BD/DVD Product - One (1) year, parts and labour**  
**Panasonic Audio Receivers - One (1) year, parts and labour**  
**Home Theater Systems Product - One (1) year, parts and labour**

This warranty is given only to the original purchaser, or the person for whom it was purchased as a gift, of a Panasonic brand product mentioned above sold by an authorized Panasonic dealer in Canada and purchased and used in Canada, which product was not sold "as is", and which product was delivered to you in new condition in the original packaging.

**IN ORDER TO BE ELIGIBLE TO RECEIVE WARRANTY SERVICE HEREUNDER, A PURCHASE RECEIPT OR OTHER PROOF OF DATE OF ORIGINAL PURCHASE, SHOWING AMOUNT PAID AND PLACE OF PURCHASE IS REQUIRED**

#### **LIMITATIONS AND EXCLUSIONS**

This warranty ONLY COVERS failures due to defects in materials or workmanship, and DOES NOT COVER normal wear and tear or cosmetic damage. The warranty ALSO DOES NOT COVER damages which occurred in shipment, or failures which are caused by products not supplied by Panasonic Canada Inc., or failures which result from accidents, misuse, abuse, neglect, mishandling, misapplication, alteration, faulty installation, set-up adjustments, misadjustment of consumer controls, improper maintenance, power line surge, lightning damage, modification, introduction of sand, humidity or liquids, commercial use such as hotel, office, restaurant, or other business or rental use of the product, or service by anyone other than an Authorized Servicer, or damage that is attributable to acts of God.

Dry cell batteries are also excluded from coverage under this warranty.

THIS EXPRESS, LIMITED WARRANTY IS IN LIEU OF ALL OTHER WARRANTIES, EXPRESS OR IMPLIED, INCLUDING ANY IMPLIED WARRANTIES OF MERCHANTABILITY AND FITNESS FOR A PARTICULAR PURPOSE. IN NO EVENT WILL PANASONIC CANADA INC. BE LIABLE FOR ANY SPECIAL, INDIRECT OR CONSEQUENTIAL DAMAGES RESULTING FROM THE USE OF THIS PRODUCT OR ARISING OUT OF ANY BREACH OF ANY EXPRESS OR IMPLIED WARRANTY. (As examples, this warranty excludes damages for lost time, travel to and from the Authorized Servicer, loss of or damage to media or images, data or other memory or recorded content. This list of items is not exhaustive, but for illustration only.)

In certain instances, some jurisdictions do not allow the exclusion or limitation of incidental or consequential damages, or the exclusion of implied warranties, so the above limitations and exclusions may not be applicable. This warranty gives you specific legal rights and you may have other rights which vary depending on your province or territory.

#### **WARRANTY SERVICE**

For product operation and information assistance, please contact:

#### **PRODUCT OPERATION ASSISTANCE**

Customer Care Centre: Telephone #: 1-800-561-5505  
Fax #: (905) 238-2360  
Email link: "Support → contact us → email" on [www.panasonic.ca](http://www.panasonic.ca)

#### **PRODUCT REPAIRS**

Please locate your nearest Authorized Servicentre.

Link: "Support → Panasonic Servicentre® locator" on [www.panasonic.ca](http://www.panasonic.ca)

#### **IF YOU SHIP THE PRODUCT TO A SERVICENTRE**

Carefully pack and send prepaid, adequately insured and preferably in the original carton.  
Include details of the defect claimed, and proof of date of original purchase.

**-If you see this symbol-**

**Information on Disposal in other Countries outside the European Union**



This symbol is only valid in the European Union. If you wish to discard this product, please contact your local authorities or dealer and ask for the correct method of disposal.



As an ENERGY STAR® Partner,\* Panasonic has determined that this product meets the ENERGY STAR® guidelines for energy efficiency.

\* For Canada only: The word "Participant" is used in place of the word "Partner".

Panasonic Consumer Marketing  
Company of North America,  
Division of Panasonic Corporation of  
North America

One Panasonic Way, Secaucus,  
New Jersey 07094

<http://www.panasonic.com>

Panasonic Canada Inc.

5770 Ambler Drive  
Mississauga, Ontario  
L4W 2T3

[www.panasonic.ca](http://www.panasonic.ca)



© Panasonic Corporation 2012  
Printed in Malaysia

RQT9777-P  
F1212RK0