

# Panasonic®

## Installation Guide

### Home Network System Water Leak Sensor

Model No. **KX-HNS103**

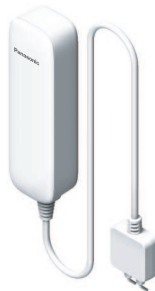

#### Thank you for purchasing a Panasonic product.

This document explains how to install the water leak sensor properly. For details about how to use the system, refer to the User's Guide (page 15).

Please read this document before using the unit and save it for future reference.

For assistance, please contact us at 1-800-272-7033 or visit our Web site: [www.panasonic.com/support](http://www.panasonic.com/support) for customers in the U.S.A. or Puerto Rico.

**Please register your product: [www.panasonic.com/prodreg](http://www.panasonic.com/prodreg)**

Printed in China

## **Table of Contents**

---

### **Introduction**

Accessory information .....3

### **Important Information**

About this system .....4

For your safety .....4

Important safety instructions .....5

For best performance .....5

Other information .....6

### **Setup**

Part names and functions .....8

About the LED indicator .....8

Setup overview .....8

Inserting the battery .....9

Registering the sensor .....9

Information about sensor  
features .....10

Wireless communication  
range .....10

Installation .....11

### **Appendix**

Features available when using the  
[Home Network] app .....15

Accessing the User's Guide ....15

Specifications .....16

FCC and other information .....17

Customer services .....18

Warranty (For United States and  
Puerto Rico) .....19

## Accessory information

### Supplied accessories

No.	Accessory item/Part number	Quantity
①	Battery*1	1
②	Wall mounting adaptors*2	2
③	Wall mounting screws (25 mm (1 inch))*3/XTB4+25AVW	3

\*1 When replacing the battery, see "Power source" of "Specifications", page 16 for battery information.

\*2 1 adaptor for the main unit: PNRH2107Z  
1 adaptor for the probe unit: PNRH2108Z

\*3 2 screws for the main unit and 1 screw for the probe unit

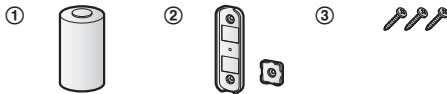

### Other information

- Design and specifications are subject to change without notice.
- The illustrations in these instructions may vary slightly from the actual product.

### Trademarks

- iPhone and iPad are registered trademarks of Apple Inc.
- Android is a trademark of Google Inc.

## Important Information

### About this system

This system is an auxiliary system; it is not designed to provide complete protection from property loss. Panasonic will not be held responsible in the event that property loss occurs while this system is in operation.

### For your safety

To prevent severe injury and loss of life/property, read this section carefully before using the product to ensure proper and safe operation of your product.

#### WARNING

##### Power connection

- Use only the power source marked on the product.
- Do not connect non-specified devices.

##### Installation

- To prevent the risk of fire or electrical shock, do not expose the product to rain.
- Do not place or use this product near automatically controlled devices such as automatic doors and fire alarms. Radio waves emitted from this product may cause such devices to malfunction resulting in an accident.
- Do not allow the cable to be excessively pulled, bent or placed under heavy objects. Keep the main unit upright at all times.

- Keep small parts (screws, etc.) out of the reach of children. There is a risk of swallowing. In the event they are swallowed, seek medical advice immediately.

##### Operating safeguards

- Do not disassemble the product.

##### Medical

- Consult the manufacturer of any personal medical devices, such as pacemakers or hearing aids, to determine if they are adequately shielded from external RF (radio frequency) energy. DECT features operate between 1.92 GHz and 1.93 GHz with a peak transmission power of 115 mW.
- Do not use the product in health care facilities if any regulations posted in the area instruct you not to do so. Hospitals or health care facilities may be using equipment that could be sensitive to external RF energy.

##### CR Lithium battery

- Do not recharge, disassemble, remodel, heat or throw it into fire.
- Do not touch the terminals  $\oplus$  and  $\ominus$  with metal objects.
- Risk of explosion if battery is replaced by an incorrect type. Dispose of used battery according to local regulations.
- If any electrolyte should come into contact with your hands or clothes, wash it off thoroughly with water.
- If any electrolyte should come into contact with your eyes, never rub your eyes. Rinse your eyes

4 For assistance, please visit [www.panasonic.com/support](http://www.panasonic.com/support)

## Important Information

thoroughly with water, and then consult a doctor.

### CAUTION

#### Installation and location

- Although this unit conforms to the IPX4\*1 specification, do not intentionally expose it to water.
  - \*1 IPX4 indicates that the unit is not harmfully affected by water sprayed on it from any direction.

#### CR Lithium battery

- Use only the battery noted on page 3.
- Insert the battery correctly.
- Do not leave the battery in an automobile exposed to direct sunlight for a long period of time with the doors and windows closed.
- Remove the battery if you do not use the product for a long period of time. Keep it in a cool, dark area.
- Do not replace a battery with wet hands.
- Keep out of the reach of small children. There is a risk of swallowing. If the battery is swallowed, seek medical attention immediately.
- Remove the battery if it becomes unusable. There is a risk of leakage, overheating, and rupture. Do not attempt to use a battery if it is leaking.
- Exercise care when handling the batteries. Do not allow conductive materials such as rings, bracelets, or keys to touch the batteries, otherwise a short circuit may cause the batteries and/or the conductive material to overheat and cause burns.

## Important safety instructions

When using your product, basic safety precautions should always be followed to reduce the risk of fire, electric shock, and injury to persons, including the following:

1. Use only the batteries indicated in this document. Do not dispose of batteries in a fire. They may explode. Check with local codes for possible special disposal instructions.

### SAVE THESE INSTRUCTIONS

## For best performance

#### Hub location/avoiding noise

The hub and other compatible Panasonic devices use radio waves to communicate with each other.

- For maximum coverage and noise-free communications, place your hub:
  - at a convenient, high, and central location with no obstructions between the product and hub in an indoor environment.
  - away from electronic appliances such as TVs, radios, personal computers, wireless devices, or other phones.
  - facing away from radio frequency transmitters, such as external antennas of mobile phone cell stations. (Avoid putting the hub on a bay window or near a window.)

For assistance, please visit [www.panasonic.com/support](http://www.panasonic.com/support)

5

## Important Information

- If the reception for a hub location is not satisfactory, move the hub to another location for better reception.

### Environment

- Keep the product away from electrical noise generating devices, such as fluorescent lamps and motors.
- The product should be kept free from excessive smoke, dust, high temperature, and vibration.
- The product should not be exposed to direct sunlight.
- Do not place heavy objects on top of the product.
- The product should be kept away from heat sources such as heaters, kitchen stoves, etc. It should not be placed in rooms where the temperature is less than 0 °C (32 °F) or greater than 40 °C (104 °F).
- Operating the product near electrical appliances may cause interference. Move away from the electrical appliances.

## Other information

**CAUTION:** Risk of explosion if battery is replaced by an incorrect type. Dispose of used batteries according to the instructions.

### Routine care

- Wipe the outer surface of the product with a soft moist cloth.
- Do not use benzine, thinner, or any abrasive powder.
- If the probe unit's metal probes become dirty or oily, the product may not detect water. Clean the

metal probes with detergent if necessary.

### Information on Disposal in other Countries outside the European Union

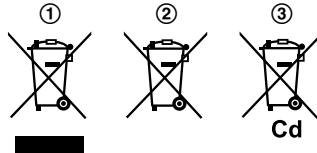

These symbols (①, ②, ③) are only valid in the European Union. If you wish to discard these items, please contact your local authorities or dealer and ask for the correct method of disposal.

### Note for the battery removal procedure

Refer to "Inserting the battery" on page 9.

## **Important Information**

### **Notice**

- This product is designed for use in the United States of America. Sale or use of this product in other countries may violate local laws.
- Cet appareil est conçu pour être utilisé aux États-Unis d'Amérique. La vente ou l'emploi de cet appareil dans certains autres pays peut constituer une infraction à la législation locale.
- Este producto está diseñado para usarse en los Estados Unidos de América. La venta o el empleo de este producto en ciertos países puede constituir violación de la legislación local.
- 本產品專為美國使用而設。若在其他國家銷售或使用，可能會違反當地法例。
- この製品は、日本国外での使用を目的として設計されており、日本国内での使用は法律違反となります。従って、当社では日本国内においては原則として修理などのサービスは致しかねます。

## Setup

### Part names and functions

#### ■ Main unit

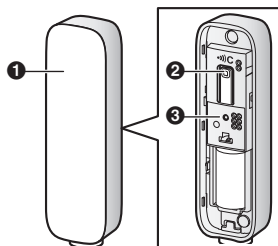

#### ■ Probe unit



- 1 Main unit cover
- 2 **[••]C**  
Used to confirm the status of the sensor or register the sensor to the hub.
- 3 LED indicator

### About the LED indicator

You can press **[••]C** and check the LED indicator to confirm the sensor's status.

Indicator	Status
Green, lit	No water detected
Red, lit	Water detected
Red, blinking	Sensor is out of range of the hub
Green, blinking	Registration mode (You pressed and held <b>[••]C</b> )
Off	No battery power

#### Note:

- The LED indicator does not indicate sensor status if the sensor has not been registered (page 9).

### Setup overview

- 1 **Initial setup**  
Make sure you can access the system using your mobile device. For details, refer to the System Setup Guide included with your hub.
- 2 **Insert the battery**  
The sensor is battery powered.
- 3 **Registration**  
Required only if the sensor was purchased separately (i.e., not as part of a bundle).
- 4 **Confirm the installation area**  
Read the information in this document to confirm that the

8 For assistance, please visit [www.panasonic.com/support](http://www.panasonic.com/support)



desired installation area is suitable for proper operation.

## 5 Installation

Install the sensor in the desired location.

### Inserting the battery

- USE ONLY a CR2 Lithium battery.
  - Confirm the polarities (+, -).
- 1 Remove the main unit cover.
    - Lift from the indented area (①) and open the main unit cover (②).

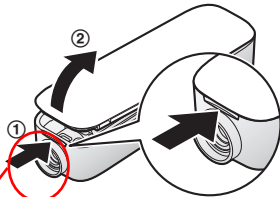

- 2 Insert the battery.

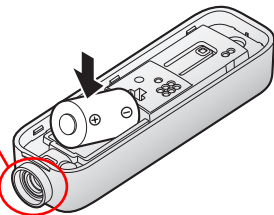

- 3 Attach the main unit cover.

ケーブルが取り外し可能な誤解を与える可能性がありますので、次校にてケーブル有りの状態に修正致します。

### Registering the sensor

This procedure is not required for devices that were included as part of a bundle.

Before you can use the sensor, it must be registered to the hub.  
If you purchased devices separately (i.e., not as part of a bundle), you must register each device to the hub.

You can register each device by using the registration buttons or the **[Home Network]** app.

#### Using registration buttons

- 1 **Hub:**  
Press and hold **[•]C OTHER DEVICE** until the LED indicator blinks in green.
- 2 **Sensor:**  
Remove the main unit cover and press and hold **[•]C** until the LED indicator blinks in green (page 8).
  - When registration is complete, the hub sounds one long beep.

#### Note:

- To cancel registration, press **[•]C** on the hub and on the sensor.
- If registration fails, the hub sounds several short beeps.

#### Using the app

When you register the sensor by using the **[Home Network]** app, you can assign a name to your devices and group them by location. For more

## Setup

information, refer to the User's Guide (page 15).

### Information about sensor features

Please read the following information before deciding where to install the sensor.

**Note:**

- The sensor is not designed to be used in situations that require high reliability. We do not recommend use of the sensor in these situations.
- Panasonic takes no responsibility for any injury or damage caused by the use of this product.

### Wireless communication range

The wireless communication range of each device in the system from the hub is approximately 50 m (160 feet) indoors and approximately 300 m (1,000 feet) outdoors. Wireless communication may be unreliable when the following obstacles are located between the hub and other devices.

- Metal doors or screens
- Walls containing aluminum-sheet insulation
- Walls made of concrete or corrugated iron
- Double-pane glass windows
- Multiple walls
- When using each device on separate floors or in different buildings

**Note:**

- You can check the sensor's communication status by pressing **[•]C**. If the LED indicator is lit in green or red, the sensor is communicating properly with the hub. If the LED indicator blinks in red, it is out of range of the hub.

### Installation



When the metal probes on the probe unit come in to contact with water, a small amount of electrical charge flows between the probes, which the main unit recognizes as a water leak.

**Note:**

- When installing, make sure the battery is inserted properly and the unit cover is completely closed.
- When installing on a wooden surface, use the included wall mounting adaptors. When securing the wall mounting adaptors to the wall, use screws (not double-sided tape).
- Mount the sensor on the stable location where the sensor can be adequately supported when mounting.
- Do not mount the sensor on a soft material. It may fall down, break or cause injury.
- Do not mount the sensor on the following places: gypsum board, ALC (autoclaved lightweight cellular concrete), concrete block, plywood less than 25.4 mm (1 inch) thick, etc.

---

### Installation location



Install the sensor in a basement, kitchen, utility room, or anywhere you want to detect a water leak. Common installation examples include near a washing machine, hot water heater, or a location where a water leak has occurred in the past.

**Note:**

- The sensor may make false detections when its metal probes are touching the floor. Mount the probe unit so that its metal probes do not touch the floor.
- Mount the main unit 1 m (3 feet 3 inches) or higher above the floor so that it will not become wet in the event of a water leak.

## Setup

### Securing with the wall mounting adaptors

- 1 Use screws to attach the wall mounting adaptors to the wall.
  - Main unit
  - Ⓐ Screws
  - Ⓑ 86.2 mm (3 25/64 inches)
  - Probe unit
  - Ⓐ Screws

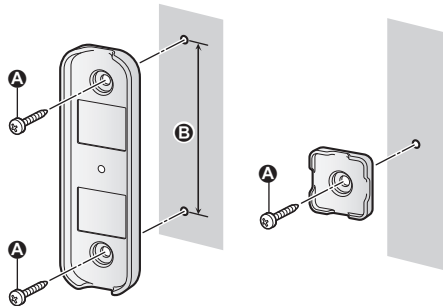

- 2 Affix double-sided tape to the main unit and probe unit.

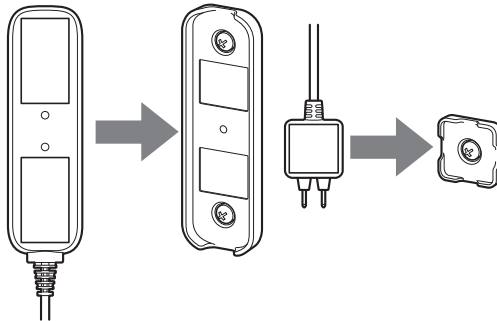

- 3 Insert the main unit and the probe unit into the wall mounting adaptors, and press firmly on each unit to ensure solid adhesion to the installation surface.

12 For assistance, please visit [www.panasonic.com/support](http://www.panasonic.com/support)

---

## Securing with double-sided tape only

**Note:**

- Make sure the surfaces of the main unit, probe unit, and the installation area are clean and dry before applying double-sided tape.

- 1 Affix double-sided tape to the main unit and probe unit.

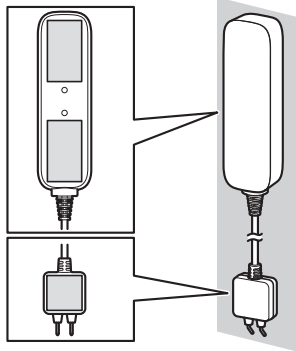

- 2 Attach the main unit and the probe unit to the installation surface, and press firmly on each unit to ensure solid adhesion to the installation surface.

## Setup

### Removing from the wall

#### ■ Removing from the wall mounting adaptors

- 1 Insert a flat screwdriver into the notches on the wall mounting adaptors, and carefully pry away the main unit and probe unit.
- 2 Remove the screws that secure the wall mounting adaptors to the wall.

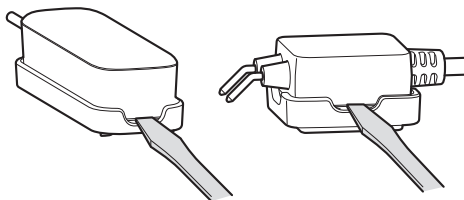

#### ■ Removing when secured with double-sided tape only

- 1 Tie a piece of thread to two sticks, screwdrivers, etc.
  - 2 Pull the thread tight and use it to cut the double-sided tape, and then remove any excess tape.
- A** Excess tape

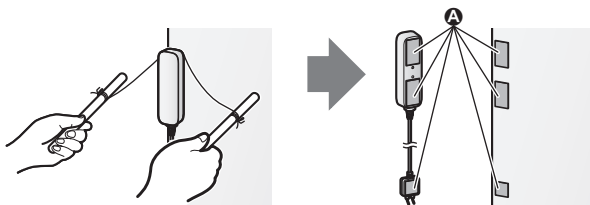



## Features available when using the [Home Network] app

Some of the sensor's features that are available when using the [Home Network] app are listed below. For more information, refer to the User's Guide (page 15).

- **Alarm system**  
You can use the app to arm and disarm the alarm system, confirm the current status of the sensor, and view a log of previous events.
- **Sensor integration**  
You can configure the sensor to trigger other system events, such as camera recording, turning on an electric device (such as a lamp), etc. (Appropriate device required.)
- **Telephone alert**  
You can configure the system to call a preprogrammed phone number when the sensor is triggered.

## Accessing the User's Guide

The User's Guide is a collection of online documentation that helps you get the most out of the [Home Network] app.

- 1 iPhone®/iPad®**  
Tap  in the app's home screen.
- Android™ devices**  
Tap  or press your mobile device's menu button in the app's home screen.
- 2 Tap [User's Guide].**

### Note:

- You can also access the User's Guide at the web page listed below.



[www.panasonic.net/pcc/support/tel/homenetwork/manual/](http://www.panasonic.net/pcc/support/tel/homenetwork/manual/)

## Appendix

### Specifications

- **Standards**  
DECT 6.0 (Digital Enhanced Cordless Telecommunications 6.0)
- **Frequency range**  
DECT: 1.92 GHz – 1.93 GHz
- **RF transmission power**  
DECT: 115 mW (max.)
- **Power source**  
Lithium battery CR2 (1 × 3.0 V, 850 mAh)
- **Operating conditions**  
0 °C – 40 °C (32 °F – 104 °F)
- **Sensor detection method**  
xx
- **Battery life**  
Approx. 3 to 4 years (when the sensor is triggered once a month, in an environment of 25 °C (77 °F))
- **IP rating**  
IPX4
- **Dimensions**  
**Main unit (not including double-sided tape):**  
Approx. 106 mm × 31 mm × 22 mm  
(4 3/16 inches × 1 1/4 inches × 7/8 inches)  
**Probe unit (not including double-sided tape):**  
Approx. 44 mm × 24 mm × 10 mm  
(1 3/4 inches × 15/16 inches × 3/8 inches)  
**Cable:**  
Approx. 1214 mm × 3.4 mm  
(47 13/16 inches × 1/8 inches)
- **Mass (weight)**  
Approx. xx g (xx lb), excluding the battery

電気ご担当者様

検知方式について、ベースとしたHNS101には記載はありませんでしたが、HNS102は検知方式についての記載がありました。

検知方式について記載は必要でしょうか？

検知方式について、記載が必要な場合は、検知方式の名称を教えてくださいませんか？

電気ご担当者様

定格表には記載されていませんが、DR0資料の「4-1. 機構設計方針」に、「防水性能:IPX4相当」の記載がありました。

こちらの記載は必要でしょうか？



## FCC and other information

This device complies with Part 15 of the FCC Rules. Operation is subject to the following two conditions:

(1) This device may not cause harmful interference, and (2) this device must accept any interference received, including interference that may cause undesired operation.

Privacy of communications may not be ensured when using this device.

### CAUTION:

Any changes or modifications not expressly approved by the party responsible for compliance could void the user's authority to operate this device.

### NOTE:

This equipment has been tested and found to comply with the limits for a Class B digital device, pursuant to Part 15 of the FCC Rules. These limits are designed to provide reasonable protection against harmful interference in a residential installation. This equipment generates, uses, and can radiate radio frequency energy and, if not installed and used in accordance with the instructions, may cause harmful interference to radio communications. However, there is no guarantee that interference will not occur in a particular installation. If this equipment does cause harmful interference to radio or television reception, which can be determined by turning the equipment off and on, the user is encouraged to try to correct the

interference by one or more of the following measures:

- Reorient or relocate the receiving antenna.
- Increase the separation between the equipment and receiver.
- Connect the equipment into an outlet on a circuit different from that to which the receiver is connected.
- Consult the dealer or an experienced radio/TV technician for help.

Some devices operate at frequencies that may cause interference to nearby TVs and VCRs. To minimize or prevent such interference, the devices should not be placed near or on top of a TV or VCR. If interference is experienced, move this device away from the TV or VCR. This will often reduce or eliminate interference.

### FCC RF Exposure Warning:

- This product complies with FCC radiation exposure limits set forth for an uncontrolled environment.
- To comply with FCC RF exposure requirements, the device must be installed and operated 20 cm (8 inches) or more between the product and all person's body.
- This product may not be collocated or operated in conjunction with any other antenna or transmitter.
- For body-worn operation, the device must be used only with a non-metallic accessory. Use of other accessories may not ensure compliance with FCC RF exposure requirements.

### Notice:

- FCC ID can be found inside the main unit.

## Appendix

### Customer services

#### ***Customer Services Directory (United States and Puerto Rico)***

Obtain Product Information and Operating Assistance; locate your nearest Dealer or Service Center; purchase Parts and Accessories; or make Customer Service and Literature requests by visiting our Web Site at:

**[www.panasonic.com/support](http://www.panasonic.com/support)**

or, contact us via the web at:

**[www.panasonic.com/contactinfo](http://www.panasonic.com/contactinfo)**

You may also contact us directly at: 1-800-272-7033,  
Monday - Friday 9 am to 9 pm; Saturday - Sunday 10 am to 7 pm, EST.

For hearing or speech impaired TTY users, TTY: 1-877-833-8855

#### ***Accessory Purchases (United States and Puerto Rico)***

Purchase Parts, Accessories and Owner's Manual online for all Panasonic Products by visiting our Web Site at:

**[www.pstc.panasonic.com](http://www.pstc.panasonic.com)**

or, send your request by E-mail to:

**[npcparts@us.panasonic.com](mailto:npcparts@us.panasonic.com)**

You may also contact us directly at: 1-800-237-9080 (Fax Only)  
(Monday - Friday 9 am to 9 pm, EST.)

Panasonic National Parts Center  
20421 84th Avenue S., Kent, WA 98032  
(We accept Visa, MasterCard, Discover Card, American Express.)

For hearing or speech impaired TTY users, TTY: 1-866-605-1277

## Warranty (For United States and Puerto Rico)

### Panasonic Home Network System Products Limited Warranty

#### Limited Warranty Coverage

If your product does not work properly because of a defect in materials or workmanship, Panasonic Corporation of North America (referred to as "the warrantor") will, for the length of the period indicated on the chart below, which starts with the date of original purchase ("Limited Warranty period"), at its option either (a) repair your product with new or refurbished parts, or (b) replace it with a new or a refurbished equivalent value product, or (c) refund your purchase price. The decision to repair, replace or refund will be made by the warrantor.

	Parts	Labor
Home Network System Products	One (1) Year	One (1) Year
microSD card (Included model only)	90 days	N/A

During the "Labor" Limited Warranty period there will be no charge for labor. During the "Parts" Limited Warranty period, there will be no charge for parts. You must mail-in your product prepaid during the Limited Warranty period. This Limited Warranty excludes both parts and labor for batteries, antennas, and cosmetic parts (cabinet). This Limited Warranty only applies to products purchased and serviced in the United States or Puerto Rico. This Limited Warranty is extended only to the original purchaser and only covers products purchased as new.

#### Mail-In Service--Online

##### Online Repair Request

To submit a new repair request and for quick repair status visit our Web Site at [www.panasonic.com/repair](http://www.panasonic.com/repair)

When shipping the unit carefully pack in a padded shipping carton, include all accessories, and send it prepaid. Include a letter detailing the complaint, a return address and provide a day time phone number where you can be reached. P.O. Boxes are not acceptable. Keep the tracking number for your records. A copy of valid registered receipt is required under the 1 year parts and labor Limited Warranty.

For Limited Warranty service for headsets if a headset is included with this product please follow instructions above.

**IF REPAIR IS NEEDED DURING THE LIMITED WARRANTY PERIOD THE PURCHASER WILL BE REQUIRED TO FURNISH A SALES RECEIPT/PROOF OF PURCHASE INDICATING DATE OF PURCHASE, AMOUNT PAID AND PLACE OF PURCHASE. CUSTOMER WILL BE CHARGED FOR THE REPAIR OF ANY UNIT RECEIVED WITHOUT SUCH PROOF OF PURCHASE.**

For assistance, please visit [www.panasonic.com/support](http://www.panasonic.com/support)

19

## Appendix

---

### Limited Warranty Limits And Exclusions

This Limited Warranty ONLY COVERS failures due to defects in materials or workmanship, and DOES NOT COVER normal wear and tear or cosmetic damage. The Limited Warranty ALSO DOES NOT COVER damages which occurred in shipment, or failures which are caused by products not supplied by the warrantor, or failures which result from accidents, misuse, abuse, neglect, bug infestation, mishandling, misapplication, alteration, faulty installation, set-up adjustments, misadjustment of consumer controls, improper maintenance, power line surge, lightning damage, modification, introduction of sand, humidity or liquids, commercial use such as hotel, office, restaurant, or other business or rental use of the product, or service by anyone other than a Factory Service Center or other Authorized Servicer, or damage that is attributable to acts of God.

**THERE ARE NO EXPRESS WARRANTIES EXCEPT AS LISTED UNDER "LIMITED WARRANTY COVERAGE". THE WARRANTOR IS NOT LIABLE FOR INCIDENTAL OR CONSEQUENTIAL DAMAGES RESULTING FROM THE USE OF THIS PRODUCT, OR ARISING OUT OF ANY BREACH OF THIS LIMITED WARRANTY.** (As examples, this excludes damages for lost time, lost calls or messages, cost of having someone remove or re-install an installed unit if applicable, travel to and from the servicer. The items listed are not exclusive, but are for illustration only.) **ALL EXPRESS AND IMPLIED WARRANTIES, INCLUDING THE WARRANTY OF MERCHANTABILITY, ARE LIMITED TO THE PERIOD OF THE LIMITED WARRANTY.**

Some states do not allow the exclusion or limitation of incidental or consequential damages, or limitations on how long an implied warranty lasts, so the exclusions may not apply to you. This Limited Warranty gives you specific legal rights and you may also have other rights which vary from state to state. If a problem with this product develops during or after the Limited Warranty period, you may contact your dealer or Service Center. If the problem is not handled to your satisfaction, then write to the warrantor's Consumer Affairs Department at the addresses listed for the warrantor.

**PARTS AND SERVICE, WHICH ARE NOT COVERED BY THIS LIMITED WARRANTY, ARE YOUR RESPONSIBILITY.**

#### When you ship the product

- Carefully pack your unit, preferably in the original carton.
- Attach a letter, detailing the symptom.
- Send the unit to Panasonic Exchange Center, prepaid and adequately insured.
- Do not send your unit to Panasonic Corporation of North America listed on the back cover or to executive or regional sales offices. These locations do not repair consumer products.

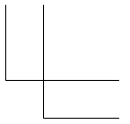
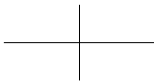
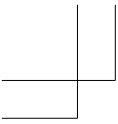

**Notes**

---

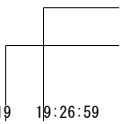
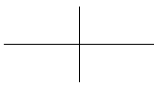
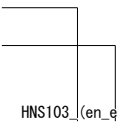
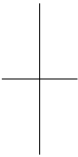

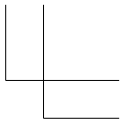
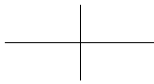
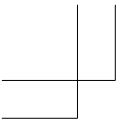

**Notes**

---

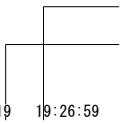
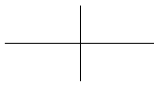
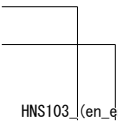
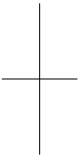

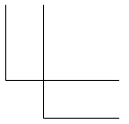
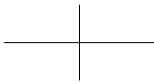
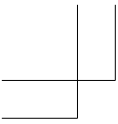

**Notes**

---

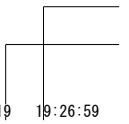
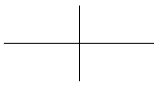
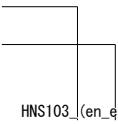
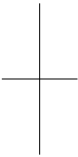

## IMPORTANT!

If your product is not working properly. . .

- ① Use **CR2 Lithium battery**.
- ② Use the **Home Network app** to access the **User's Guide** and refer to the **Troubleshooting** section.



Visit our Web site: [www.panasonic.com/support](http://www.panasonic.com/support)  
•FAQ and troubleshooting hints are available.

### For your future reference

We recommend keeping a record of the following information to assist with any repair under warranty.

Serial No.	Date of purchase
------------	------------------

(found inside the main unit)

Name and address of dealer
----------------------------

Attach your purchase receipt here.
------------------------------------

Panasonic Corporation of North America

Two Riverfront Plaza, Newark, NJ 07102-5490

© Panasonic System Networks Co., Ltd. 2015