

# Panasonic

2.4GHz FHSS Cordless Answering System

Model No. **KX-TG2200B**

Pulse-or-tone-dialing capability

## Operating Instructions

### Contents:

Location of controls	2
Installation	5
Handset battery charge	10
Making/Answering calls with the base unit	11
Making/Answering calls with the cordless handset	12
Caller ID Service	13
Voice Mail System	13
Automated Attendant System	14
Answering System	15
Listening to messages	16
Important Safety Instructions	17
FCC and other information	19

**PLEASE READ BEFORE USE AND SAVE.**

**Charge the battery for about 8 hours before initial use.**

Please read **IMPORTANT SAFETY INSTRUCTIONS** on page 17 before use. Read and understand all instructions.

## Location of controls

■ **Base Unit**

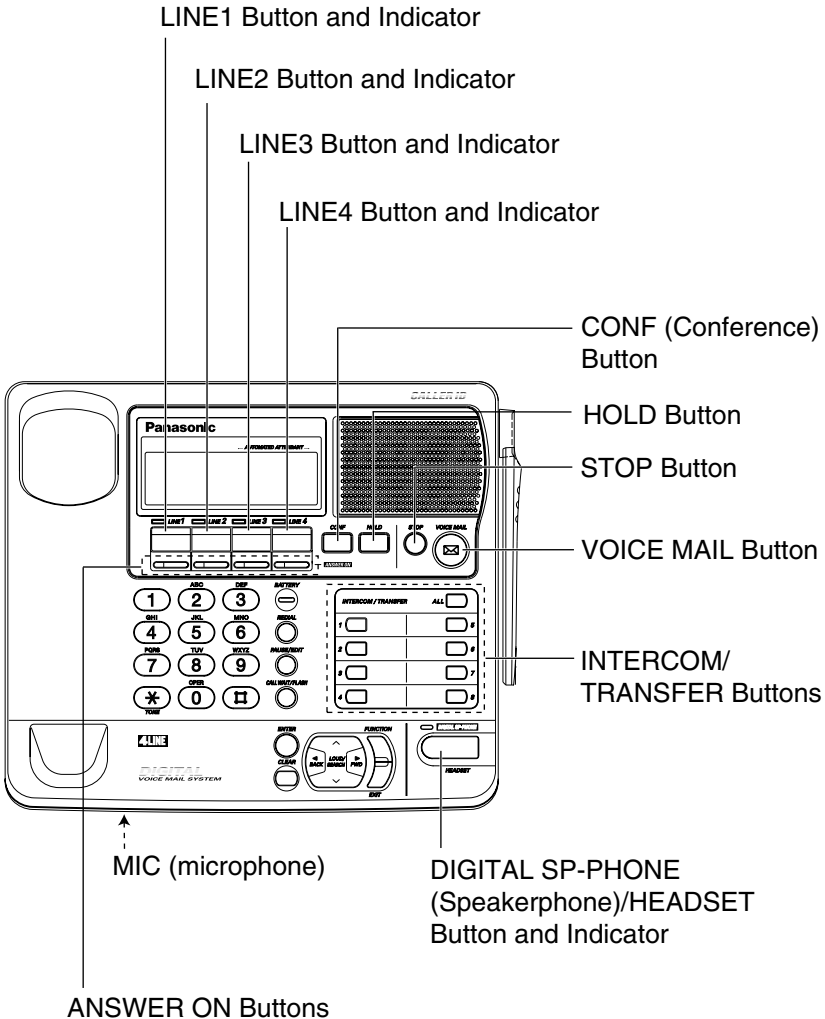

■ Base Unit

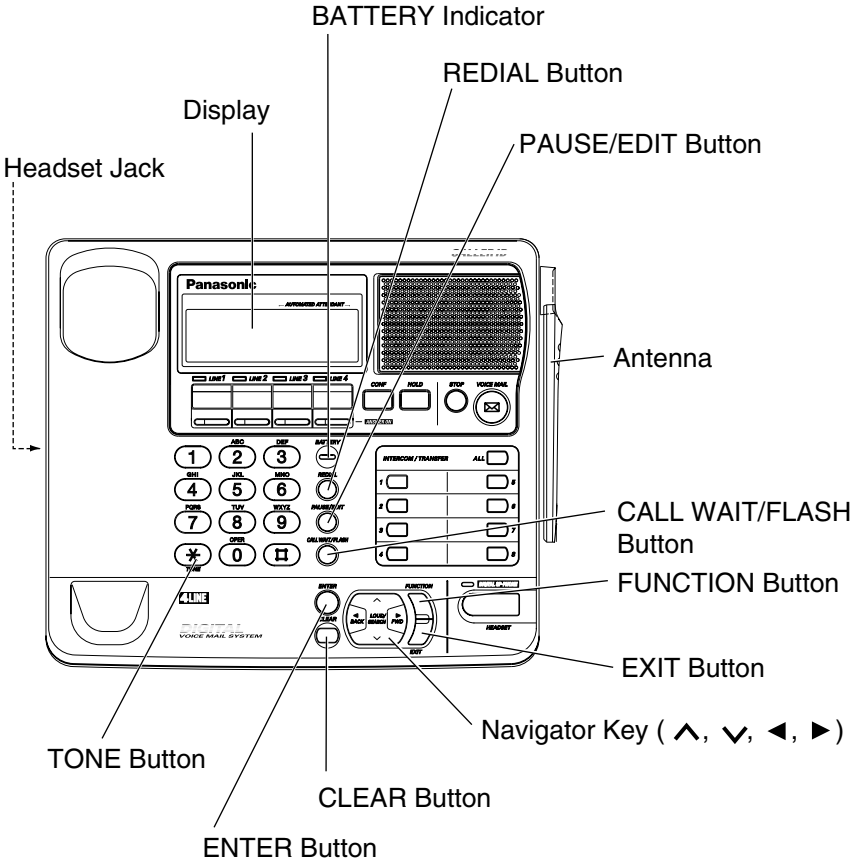

■ Cordless Handset

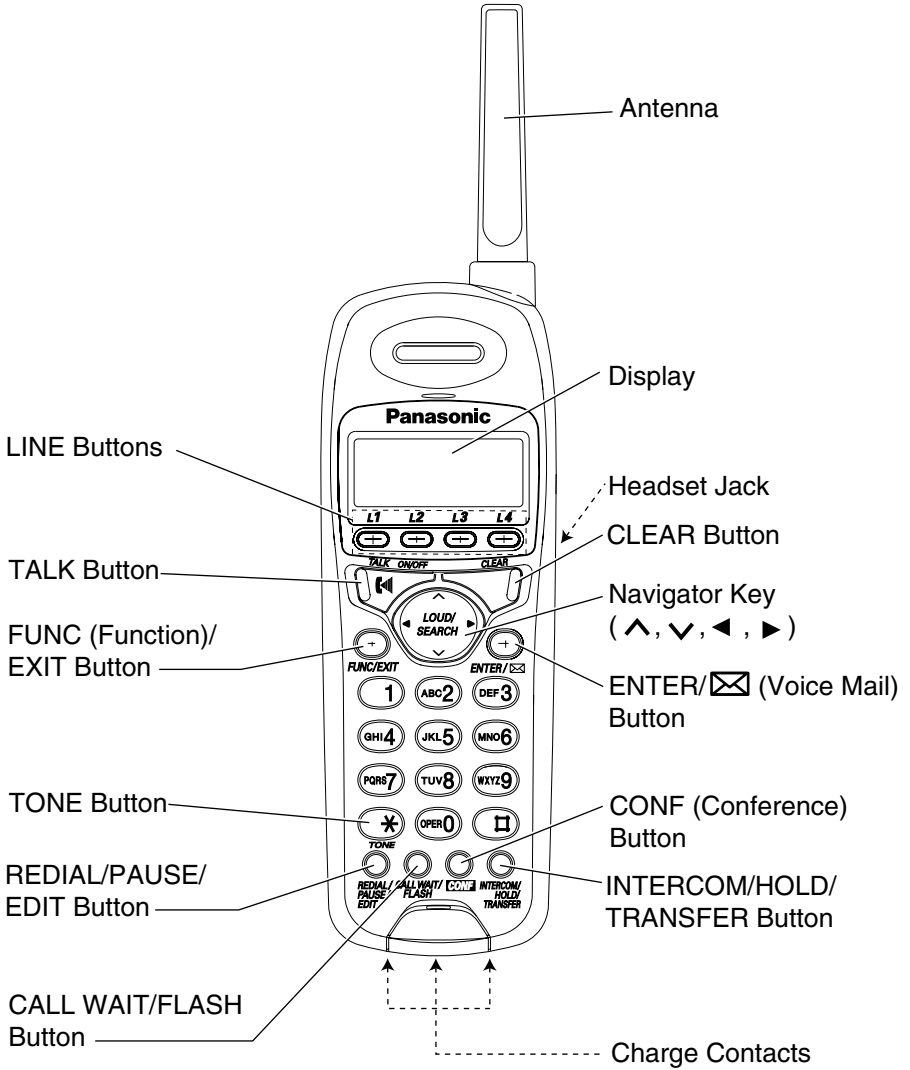

## ■ Charger

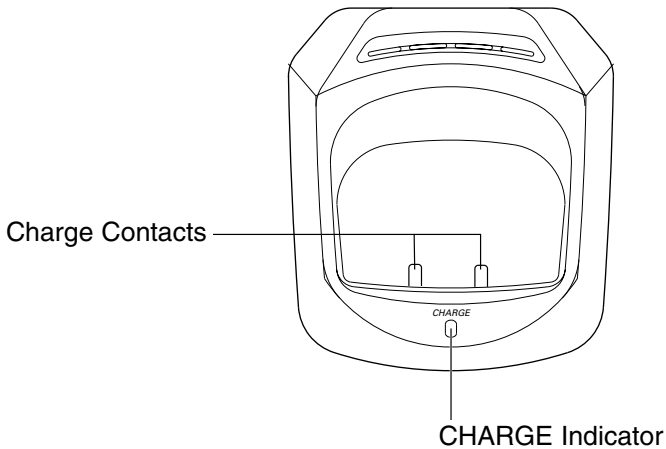

## Installation

### ■ Installing the backup battery in the base unit

A rechargeable Ni-Cd battery works as emergency power during a power failure. The fully charged backup battery provides the base unit with 20 minutes operation. The battery is charged in the base unit while the AC adaptor is connected. It takes 10 hours to charge fully.

Install the backup battery in the battery compartment, and close the cradle cover.

- The battery cannot be overcharged.

#### **Attention:**

The product you have purchased is powered by a nickel cadmium battery which is recyclable.

At the end of its useful life, under various state and local laws, it is illegal to dispose of this battery into your municipal waste stream. Please call 1-800-8-BATTERY for information on how to recycle this battery.



■ Connect the handset to the base unit

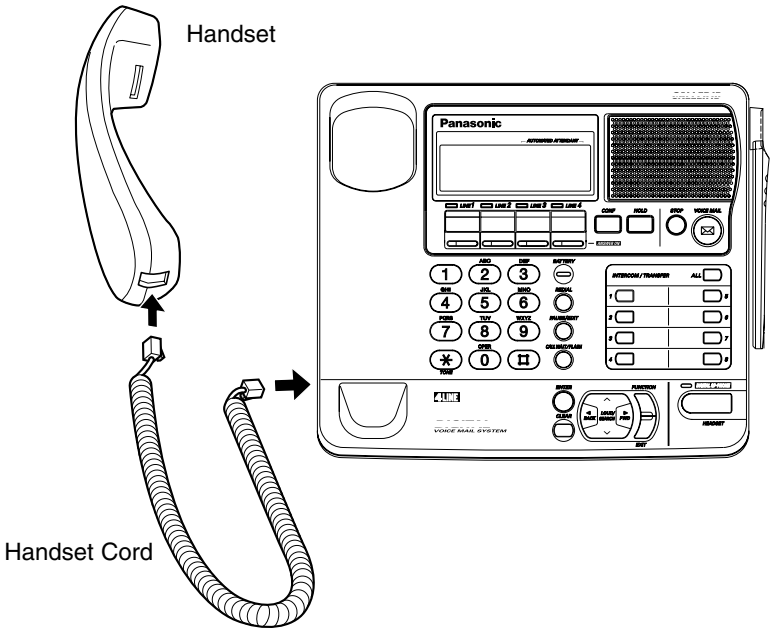

- Use only a Panasonic Handset for the KX-TG2200B.

■ Connect the AC adaptor to the base unit

Raise the antenna.

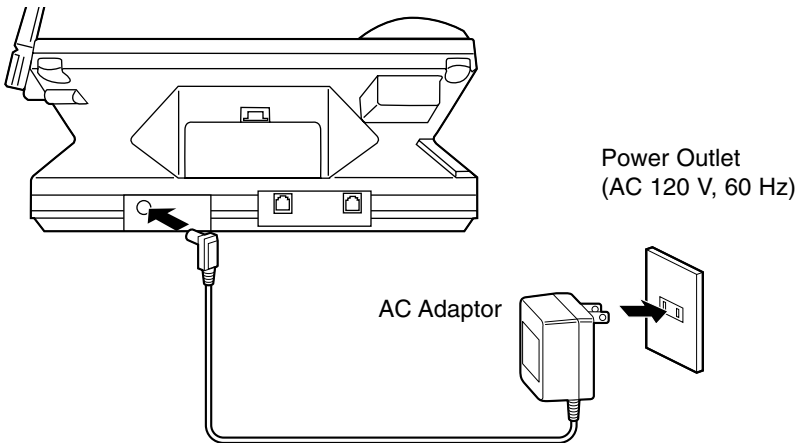

- USE ONLY WITH Panasonic AC ADAPTOR PQLV12.
- The AC adaptor must remain connected at all times. (It is normal for the adaptor to feel warm during use.)

■ Connecting the telephone line cord to 2 two-line telephone jack

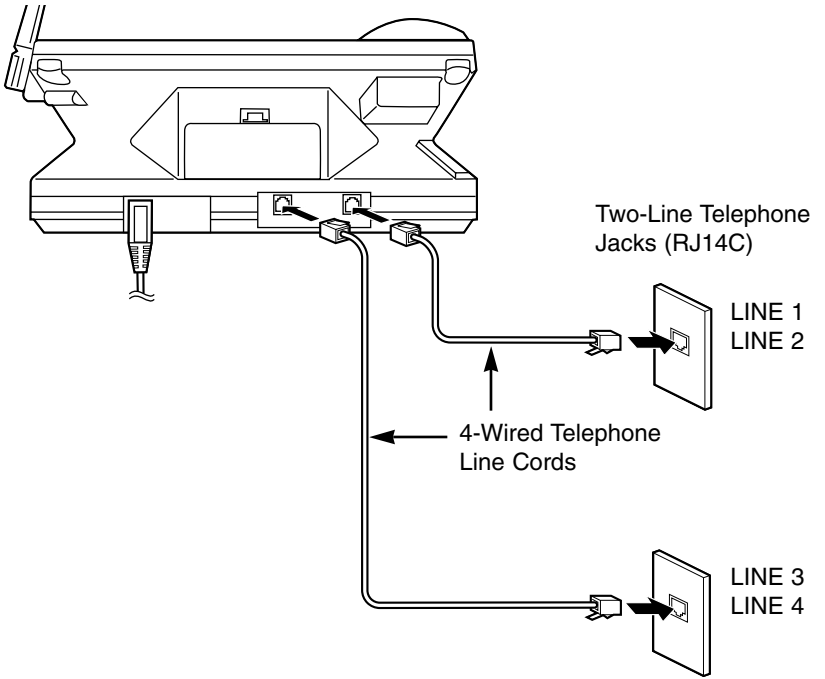

## ■ Connecting the telephone line cords to four single-line telephone jacks

For this connection, please purchase two Panasonic T-adaptors and two 2-wired telephone line cords.

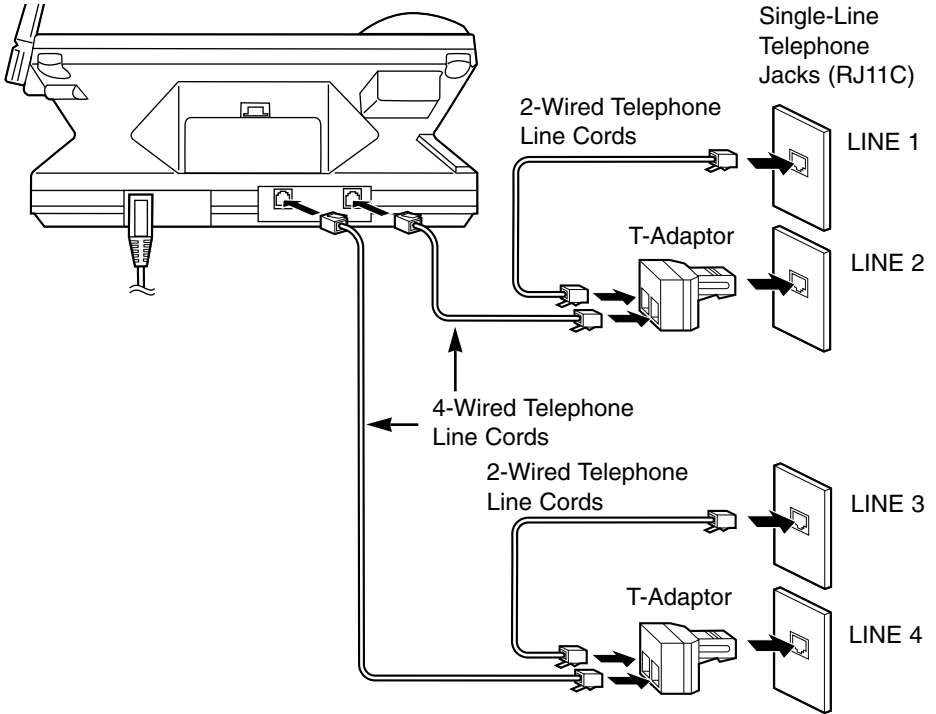



## ■ Connecting the AC Adaptor to the charger

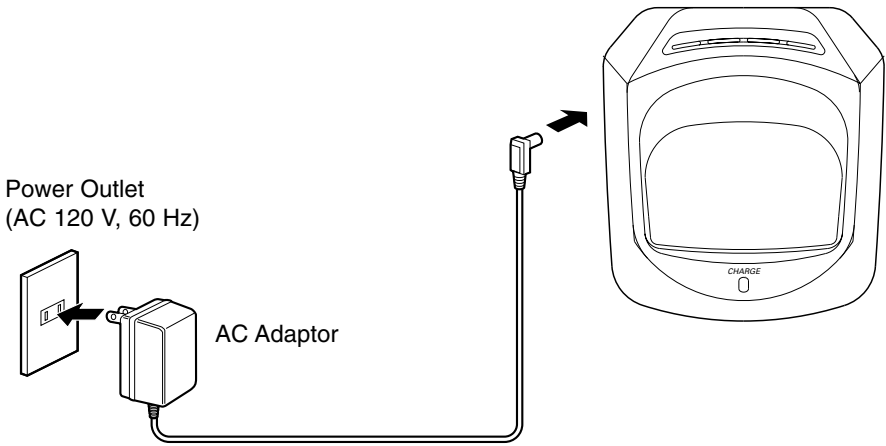

- USE ONLY WITH Panasonic AC ADAPTOR TCA1.
- The AC adaptor must remain connected at all times. (It is normal for the adaptor to feel warm during use.)

# Handset battery charge

To power the cordless handset, charge the battery.

Place the handset on the charger for about 8 hours before initial use.

- The CHARGE indicator lights.

## ■ Recharge

Recharge the battery when:

–"  " flashes on the display, or

– the handset beeps every minute while it is in use.

- Clean the charge contacts of the handset and charger with a soft dry cloth once a month. Clean more often if the unit is subject to grease, dust or high humidity.** If not, the battery may not charge properly.
- If the battery is fully charged, you do not have to place the handset on the charger until "  " flashes. This will maximize the battery life.
- The battery cannot be overcharged.

# Making/Answering calls with the base unit

## ■ To make a call

When you lift the handset to make a call, the unit will automatically select a free line.

### Using the digital duplex speakerphone:

- 1 Press DIGITAL SP-PHONE.
    - The indicator and the selected line indicator light.
  - 2 Dial a telephone number.
  - 3 Talk into the **MIC** (microphone).
  - 4 To hang up, press DIGITAL SP-PHONE.
    - The indicator lights go out.
- In step 1, you may select a line manually by pressing the line button instead of DIGITAL SP-PHONE.
  - **To redial the last number:** Lift the handset or press DIGITAL SP-PHONE, then press REDIAL.
  - **To adjust the handset volume (4 levels)/speaker volume (8 levels):**  
To increase, press **▲**. To decrease, press **▼**.
  - **To put a call on hold:** Press HOLD.
  - **To release the hold,** press the line button.

## ■ To answer a call

Lift the handset.

OR

Press DIGITAL SP-PHONE, then talk into the **MIC** (microphone).

- You can answer a call by pressing the line button instead of DIGITAL SP-PHONE.

# Making/Answering calls with the cordless handset

## ■ To make a call

- 1 Press TALK.
  - 2 Dial a telephone number.
  - 3 To hang up, press TALK or place the handset on the charger.
    - The indicator lights go out.
- If "Out of range" is displayed and an alarm tone sounds in step 1, move closer to the base unit, and try again.
  - In step 1, you may select a line manually by pressing the line button instead of TALK.
  - **To redial the last number**, press TALK, then press REDIAL.
  - **To adjust the receiver volume (4 levels):**  
To increase, press  $\wedge$  . To decrease, press  $\vee$  .
  - **To put a call on hold**, press HOLD.
  - **To release the hold**, press the line button.

## ■ To answer a call

Press TALK.

- You can answer a call by pressing the line button instead of TALK.

## Caller ID Service

This unit is compatible with a Caller ID service offered by your telephone company.

After subscribing to a Caller ID service, the calling party's information will be shown on the base unit and cordless handset displays after the first ring.

The base unit can record information of up to 50 different callers in the caller list. Each cordless handset can record information of up to 30 different callers in the caller list. The Caller List information is sorted from the most recent to the oldest call. When the base unit receives the 51st call or the handset receives the 31st call, the oldest call is deleted.

If your unit is connected to a PBX system which does not support Caller ID services, you cannot access those services. Please consult your equipment supplier.

## Voice Mail System

The Voice Mail System is a voice message receiving and delivery system which allows callers to leave messages in the mailboxes.

The unit accommodates one general delivery mailbox and a maximum of 8 personal mailboxes for the cordless handsets.

The Voice Mail System fully works with the automated attendant system. This system routes incoming calls to the specified mailbox. If a caller did not specify the mailbox, the call is routed to the general delivery mailbox.

If you select the answering system, all calls are routed to the general delivery mailbox.

The base unit and cordless handset users can use the Voice Mail System features by accessing their mailboxes.

Each cordless handset user can only access to his/her own mailbox. The general delivery mailbox is managed by the base unit user. However, any cordless handset users can access to this mailbox.

The following features are accessible:

- listening to the recorded messages
- transferring the mailbox messages to the destination mailboxes
- delivering their own messages to the destination mailboxes

# Automated Attendant System

You can set this system to your desired lines to suit your needs.

The automated attendant answers incoming calls and routes the callers to the base unit or the desired cordless handset.

## ■ To select the automated attendant system

You can record up to 4 greeting messages (up to 2 minutes each), and assign one of them to the line.

• All messages (greeting, incoming, etc.) are stored in digital memory. **The total recording time is about 50 minutes.** We recommend you record a brief greeting message in order to leave more time in memory.

If you do not record a greeting message, the pre-recorded greeting message can be selected.

### To select the pre-recorded message:

- 1 Press the desired line's ANSWER ON button.
- 2 Press FUNCTION within 10 seconds.
- 3 Press ▼ or ▲ to select "Auto attendant", and press ►.
- 4 Press ►.
  - The pre-recorded message is played.
  - The line's auto attendant icon will be displayed.

### To record your greeting message:

- 1 Press the desired line's ANSWER ON button.
- 2 Press FUNCTION within 10 seconds.
- 3 Press ▼ or ▲ to select "Auto attendant", and press ►.
- 4 Press ▼ to select "Greeting1".
- 5 Press ►.
- 6 Press ►.
  - "Record greeting at the tone" is heard.
- 7 Talk clearly, about 8 inches (20 cm) away from the **MIC** (microphone).
- 8 Press ►.
  - The recorded message is played.
  - The line's auto attendant icon will be displayed.

# Answering System

If you can set this system for your desired lines, the unit will answer a call with a greeting message, and the caller can leave a message.

## ■ To select the answering system

Select the number of times the unit rings before the answering system answers a call.

You can record up to 4 desired greeting messages (up to 2 minutes each), and assign one of them to the line.

- All messages (greeting, incoming, etc.) are stored in digital memory. **The total recording time is about 50 minutes.** We recommend you record a brief greeting message in order to leave more time in memory.

If you do not record a greeting message, the pre-recorded greeting message can be selected.

## To select the pre-recorded message:

- 1 Press the desired line's ANSWER ON button.
- 2 Press FUNCTION within 10 seconds.
- 3 While "Auto answering" is at the arrow, press ►.
- 4 Select the desired setting, "2" to "7" or "Toll Saver", by pressing ▼ or ▲, and pressing ►.
- 5 Press ►.
  - The pre-recorded message is played.



## To record your greeting message:

- 1 Follow steps 1 to 4 above.
- 2 Press ▼ to select "Greeting1".
- 3 Press ►.
- 4 Press ►.
  - "Record greeting at the tone" is heard.
- 5 Talk clearly.
- 6 Press ►.
  - The recorded message is played.



# Listening to messages

## ■ With the base unit

### To listen to only new messages in the general delivery mailbox:



- 1 Press .
  - The unit announces the number of new messages and the new messages are played.
- 2 After listening to all new messages, press .

### To listen to all new messages in the general delivery mailbox:



- 1 Press , and press .
- The unit announces the number of all messages and plays them back.
- 2 After listening to all messages, press .

## ■ With the cordless handset

### To listen to only new messages in the mailbox:

- 1 Press .
- The unit announces the number of new messages and the new messages are played.
- 2 After listening to all new messages, press .

### To listen to all new messages in the mailbox:

- 1 Press , and press .
- The unit announces the number of all messages and plays them back.
- 2 After listening to all messages, press .



# Important Safety Instructions

When using this unit, basic safety precautions should always be followed to reduce the risk of fire, electric shock, or personal injury.

1. Read and understand all instructions.
2. Follow all warnings and instructions marked on this unit.
3. Unplug this unit from AC outlets before cleaning. Do not use liquid or aerosol cleaners. Use a damp cloth for cleaning.
4. Do not use this unit near water, for example, near a bathtub, washbowl, kitchen sink, or the like.
5. Place this unit securely on a stable surface. Serious damage and/or injury may result if the unit falls.
6. Do not cover slots and openings on the unit. They are provided for ventilation and protection against overheating. Never place the unit near radiators, or in a place where proper ventilation is not provided.
7. Use only the power source marked on the unit. If you are not sure of the type of power supplied to your home, consult your dealer or local power company.
8. Do not place objects on the power cord. Install the unit where no one can step or trip on the cord.
9. Do not overload wall outlets and extension cords. This can result in the risk of fire or electric shock.
10. Never push any objects through slots in this unit. This may result in the risk of fire or electric shock. Never spill any liquid on the unit.
11. To reduce the risk of electric shock, do not disassemble this unit. Take the unit to an authorized servicer when service is required. Opening or removing covers may expose you to dangerous voltages or other risks. Incorrect reassembly can cause electric shock when the unit is subsequently used.
12. Unplug this unit from the wall outlet and refer servicing to an authorized servicer when the following conditions occur:
  - A. When the power supply cord or plug is damaged or frayed.
  - B. If liquid has been spilled into the unit.
  - C. If the unit has been exposed to rain or water.
  - D. If the unit does not work normally by following the operating instructions.

Adjust only controls covered by the operating instructions. Improper adjustment may require extensive work by an authorized servicer.
  - E. If the unit has been dropped or physically damaged.
  - F. If the unit exhibits a distinct change in performance.
13. During thunderstorms, avoid using telephones except cordless types. There may be a remote risk of an electric shock from lightning.
14. Do not use this unit to report a gas leak, when in the vicinity of the leak.

## SAVE THESE INSTRUCTIONS

**CAUTION:**

To reduce the risk of fire or injury to persons, read and follow these instructions.

1. Use only the battery(ies) specified.
2. Do not dispose of the battery(ies) in a fire. They may explode. Check with local waste management codes for special disposal instructions.
3. Do not open or mutilate the battery(ies). Released electrolyte is corrosive and may cause burns or injury to the eyes or skin. The electrolyte may be toxic if swallowed.
4. Exercise care in handling batteries in order not to short the battery to conductive materials such as rings, bracelets, and keys. The battery and/or conductor may overheat and cause burns.
5. Charge the battery(ies) provided with or identified for use with this product only in accordance with the instructions and limitations specified in this manual.

**WARNING:**

TO PREVENT FIRE OR SHOCK HAZARD, DO NOT EXPOSE THIS PRODUCT TO RAIN OR ANY TYPE OF MOISTURE.

## FCC and other information

If requested by the telephone company, inform them as follows:

FCC Registration No. .... (found on the bottom of the unit)  
Facility Interface Code ..... 02LS2  
Service Order Code .....9.0F  
Required Network Interface Jack.....RJ11, RJ14  
Ringer Equivalence ..... 0.2B  
The particular telephone lines to which the equipment is connected.

This unit must not be connected to a coin operated line.

If you are on a party line, check with your local telephone company.

### **Ringer Equivalence No. (REN):**

The REN is useful in determining the quantity of devices you may connect to your telephone line and still have all of those devices ring when your telephone number is called. In most, but not all areas, the sum of the REN's of all devices connected to one line should not exceed five (5.0). To be certain of the number of devices you may connect to your line, as determined by the REN, you should contact your local telephone company to determine the maximum REN for your calling area.

In the event terminal equipment causes harm to the telephone network, the telephone company should notify the customer, if possible, that service may be stopped. However, where prior notice is impractical, the company may temporarily cease service providing that they:

- (a) Promptly notify the customer.
- (b) Give the customer an opportunity to correct the problem with their equipment.
- (c) Inform the customer of the right to bring a complaint to the Federal Communication Commission pursuant to procedures set out in FCC Rules and Regulations Subpart E of Part 68.

The Telephone Company may make changes in its communications facilities, equipment, operations or procedures, where such action is reasonably required in the operation of its business and is not inconsistent with the rules and regulations in FCC Part 68.

If such changes can be reasonably expected to render any customer terminal equipment incompatible with telephone company communications facilities, or require modification or alteration of such terminal equipment, or otherwise materially affect its use or performance, the customer shall be given adequate notice in writing, to allow the customer an opportunity to maintain uninterrupted service.

When programming emergency numbers and/or making test calls to emergency numbers:

1. Remain on the line and briefly explain to the dispatcher the reason for the call before hanging up.
2. Perform such activities in the off-peak hours, such as early morning hours or late evenings.

This device complies with Part 15 of the FCC Rules. Operation is subject to the following two conditions:

(1) This device may not cause harmful interference, and (2) this device must accept any interference received, including interference that may cause undesired operation.

Privacy of communications may not be ensured when using this phone.

**CAUTION:**

Any changes or modifications not expressly approved by the party responsible for compliance could void the user's authority to operate this device.

**Note:**

This equipment has been tested and found to comply with the limits for a Class B digital device, pursuant to Part 15 of the FCC Rules. These limits are designed to provide reasonable protection against harmful interference in a residential installation. This equipment generates, uses, and can radiate radio frequency energy and, if not installed and used in accordance with the instructions, may cause harmful interference to radio communications. However, there is no guarantee that interference will not occur in a particular installation. If this equipment does cause harmful interference to radio or television reception, which can be determined by turning the equipment off and on, the user is encouraged to try to correct the interference by one or more of the following measures:

- Reorient or relocate the receiving antenna.
- Increase the separation between the equipment and receiver.
- Connect the equipment into an outlet on a circuit different from that to which the receiver is connected.
- Consult the dealer or an experienced radio/TV technician for help.

Some cordless telephones operate at frequencies that may cause interference to nearby TVs and VCRs. To minimize or prevent such interference, the base of the cordless telephone should not be placed near or on top of a TV or VCR. If interference is experienced, move the cordless telephone further away from the TV or VCR. This will often reduce or eliminate interference.

- **Environment** — do not place the unit in a room where the temperature is less than 5°C (41°F) or greater than 40°C (104°F). Allow 10 cm (4") clearance around the unit for proper ventilation. Avoid excessive smoke, dust, mechanical vibration, shock, or direct sunlight.
- **Medical** — consult the manufacturer of any personal medical devices, such as pacemakers, to determine if they are adequately shielded from external RF (radio frequency) energy. (The unit operates in the frequency range of 2401MHz to 2478MHz.) Do not use the unit in health care facilities if any regulations posted in the area instruct you not to do so. Hospitals or health care facilities may be using equipment that could be sensitive to external RF (radio frequency) energy.
- **Routine care** — wipe the unit with a soft cloth. Do not use benzene, thinner, or any abrasive powder. When you leave the unit unused for a long period of time, unplug the AC adaptor from the outlet.
- **If there is any trouble** — disconnect the unit from the telephone line and connect a known working phone. If the known working phone operates properly, have your unit repaired by one of the authorized Panasonic Factory Service Centers. If the known working phone does not operate properly, consult your telephone company.

- This cordless telephone is designed for use in the United States of America. Sale or use of this product in other countries may violate local laws.
- Ce téléphone sans fil est conçu pour être utilisé aux États-Unis d'Amérique. La vente ou l'emploi de cet appareil dans certains autres pays peut constituer une infraction à la législation locale.
- Este teléfono sin cordón fue elaborado para uso en los Estados Unidos de América. La venta o el empleo de este producto en ciertos países puede constituir violación de la legislación local.
- このコードレス電話機は、日本国外での使用を目的として設計されており、日本国内での使用は法律違反となります。従って、当社では日本国内においては原則として修理などのサービスは致しかねます。

### **For product service**

- Panasonic Servicenters are listed in the servicenter directory.
- Call 1-800-211-PANA(7262) for the location of an authorized servicenter.

### **When you ship the product**

- Carefully pack your unit, preferably in the original carton.
- Attach a letter, detailing the symptom, to the outside of the carton.

Symptom \_\_\_\_\_

- Send the unit to an authorized servicenter, prepaid and adequately insured.
- Do not send your unit to the Panasonic Consumer Electronics Company listed on the back cover or to executive or regional sales offices. These locations do not repair consumer products.

### **For your future reference**

Serial No. \_\_\_\_\_ Date of purchase \_\_\_\_\_

(found on the bottom of the unit)

Name and address of dealer \_\_\_\_\_

**Panasonic Consumer Electronics Company,**  
**Division of Matsushita Electric Corporation of America**  
One Panasonic Way, Secaucus, New Jersey 07094

**Panasonic Sales Company,**  
**Division of Matsushita Electric of Puerto Rico, Inc.**  
Ave. 65 de Infantería, Km. 9.5, San Gabriel Industrial Park  
Carolina, Puerto Rico 00985