

**Panasonic**<sup>®</sup>

## **Operating Instructions**

Home Communication System

Model No. **KX-TH102-C**

**2LINE**

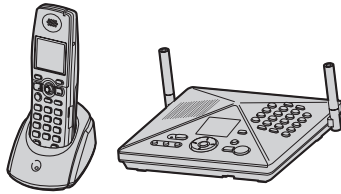

This unit is compatible with Caller ID. To use this feature, you must subscribe to the appropriate service offered by your service provider.

**Charge the handset battery for 6 hours before initial use.**

Please read these Operating Instructions before using the unit and save for future reference.

For assistance, visit our website:

**<http://www.panasonic.com/phonehelp>** for customers in the U.S.A. or Puerto Rico.

## Table of Contents

### Introduction

Feature highlights . . . . .	3
Accessory information . . . . .	5
Expanding your phone system . . . . .	7
Important safety instructions . . . . .	10
For best performance . . . . .	12

### Preparation

Setting up the base unit . . . . .	13
Setting up the handset . . . . .	16
Battery charge . . . . .	16
Battery replacement . . . . .	17
Controls . . . . .	18
Displays . . . . .	21
Symbols used in these operating instructions . . . . .	22
Setting the unit before use . . . . .	23

### Making/Answering Calls

Making calls . . . . .	25
Answering calls . . . . .	26
Useful features during a call . . . . .	27
Using the other line during a call . . . . .	28

### Phonebook

Handset phonebook . . . . .	29
Base unit phonebook . . . . .	32

### Caller ID Service

Using Caller ID service . . . . .	34
Caller list . . . . .	35

### Intercom

Intercom feature . . . . .	38
Transferring a call . . . . .	39
Conference calls . . . . .	40
Call share . . . . .	42

### Monitoring

Monitoring feature . . . . .	43
Audio monitor . . . . .	43

### Programmable Settings

Ringer settings . . . . .	44
Other settings . . . . .	47
Registering a unit . . . . .	51

### Answering System

Answering system feature . . . . .	52
Setting up the answering system . . . . .	53
Listening to messages using the base unit . . . . .	54
Listening to messages using the handset . . . . .	55
Voice memo . . . . .	56
Remote operation . . . . .	56
Answering system settings . . . . .	58

### Using a Cellular Phone with this Unit

Configuring a cellular phone . . . . .	61
Making/answering calls using a cellular line . . . . .	62
Useful features during a cellular call . . . . .	63
Cellular settings . . . . .	64
Transferring a cellular call . . . . .	65
Conference calls . . . . .	67

### Useful Information

Connecting to your LAN . . . . .	69
Wall mounting . . . . .	70
Headset (Optional) . . . . .	72
Error messages . . . . .	73
Troubleshooting . . . . .	75
FCC and other information . . . . .	79
Specifications . . . . .	82
Warranty . . . . .	83
Customer services . . . . .	85
Direct commands chart/programming index . . . . .	86

### Index

Index . . . . .	89
-----------------	----

## Introduction

### Feature highlights

Thank you for purchasing a Panasonic Home Communication System.

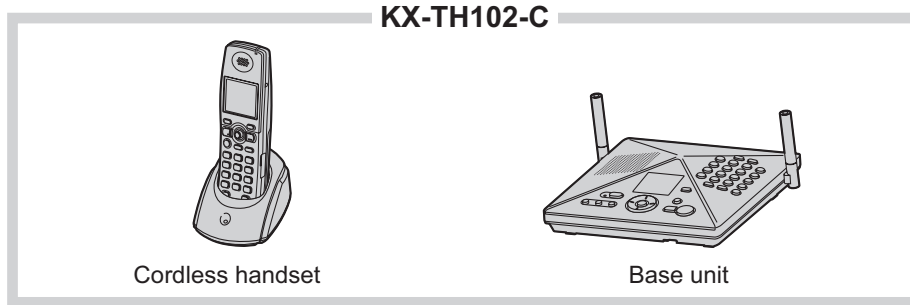

#### Important:

- KX-TH102-C includes a cordless handset (KX-THA11) and a base unit.
- In these operating instructions, the included cordless handset is referred to as the "handset".

### Telephone features

#### ■ 2 line telephone

While one line is in use, you can make or answer a call using the other line.

#### ■ Audio monitor (between handset and base unit)

You can listen to the audio in the room where the handset or base unit is located (page 43).

#### ■ Customize ring

You can connect an audio device to the handset using the included audio cable and record songs to be used as the handset ringer tone (page 46).

#### ■ Cellular convergence

Bluetooth-compatibility allows you to make or answer calls using a cellular line (page 61).

#### Trademarks

- Bluetooth is a registered trademark of Bluetooth SIG, Inc.

## **Introduction**

---

### **MULTI TALK V software**

The included CD-ROM contains the MULTI TALK V Utility suite. The suite consists of the following utilities. Refer to the included "Installation Guide for MULTI TALK V Software" for installation details.

#### **■ MULTI TALK V USB Utility**

Allows you to use your computer to:

- Add, edit, erase, and backup phonebook entries
- Send melodies stored in your computer to your phone
- Play, erase, and save answering system messages
- Change phone settings
- Connect to the Internet or to another computer using a MULTI TALK V phone

#### **■ MULTI TALK V Camera Utility**

Allows you to use your computer to register a cordless camera (sold separately) in order to view cordless camera images with a web browser.







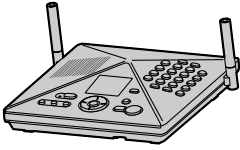

#### **■ MULTI TALK V Printing Utility**

Allows you to use your computer to register a KX-THA16 (sold separately) in order to print images from the KX-THA16 to your computer's printer.

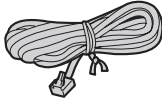
**Introduction**

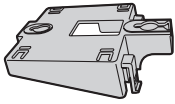
**Accessory information**

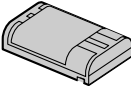
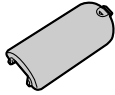
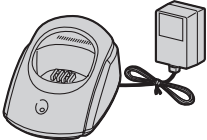
**Included parts**

<p><input type="checkbox"/> Base unit</p> 	<p><input type="checkbox"/> AC adaptor for base unit (Order No. PQLV205Z)</p> 	<p><input type="checkbox"/> 4-wire telephone line cord with green plugs (Order No. PQJA10088Z)</p> 
<p><input type="checkbox"/> 2-wire telephone line cord with transparent plugs (Order No. PQJA10075Z)</p> 	<p><input type="checkbox"/> LAN cable (Order No. PQJA10169Z)</p> 	<p><input type="checkbox"/> Wall mounting adaptor for base unit (Order No. PQKL10070Z1)</p> 
<p><input type="checkbox"/> Handset</p> 	<p><input type="checkbox"/> Battery (Order No. HHR-P104)</p> 	<p><input type="checkbox"/> Handset cover (Order No. PQYNTHA11R)</p> 
<p><input type="checkbox"/> Charger for handset – Charger: (Order No. PQLV30038ZS) – AC adaptor: (Order No. PQLV203Z)</p> 	<p><input type="checkbox"/> Audio cable (Order No. PQJA10172Z)</p> 	<p><input type="checkbox"/> Belt clip (Order No. PQKE10404Z1)</p> 

## Introduction

USB cable  
(Order No. PQJA10166Z)

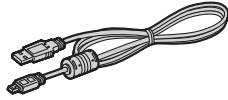

CD-ROM\*1  
(Order No. PQJKTH102Z)

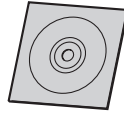

\*1 Allows you to install the MULTI TALK V software on a compatible computer. Refer to the included "Installation Guide for MULTI TALK V Software" for details.

### Other additional/replacement accessories

- To order these accessories, call 1-800-332-5368.  
TTY users (hearing or speech impaired users) can call 1-866-605-1277.

Accessory item	Order number
Rechargeable nickel metal hydride (Ni-MH) battery	HHR-P104
Headset	KX-TCA60, KX-TCA86, KX-TCA88HA, KX-TCA91, KX-TCA92, KX-TCA98
T-adaptor	KX-J66
2-line splitter	KX-J42

### Note:





- You can expand your phone system by registering additional compatible Panasonic units (page 7).

## Introduction

### Expanding your phone system

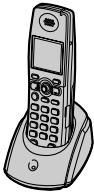
You can expand the phone system by adding the following units.

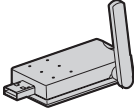
- To order these units, call 1-800-332-5368.  
TTY users (hearing or speech impaired users) can call 1-866-605-1277.

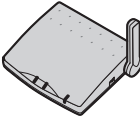
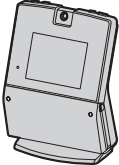
<p><b>Additional handset</b></p> <p>Cordless handset: KX-THA11 (Monochrome display type)</p> 	<p><b>For monitoring</b></p> <p>Cordless camera: KX-THA13</p> 
<p>Cordless video camera handset: KX-THA12 (Color display type)</p> 	<p><b>For data link</b></p> <p>USB adaptor: KX-THA14</p> 
<p>Cordless video camera handset with TV output: KX-THA17 (Color display type with audio/video outlet jack)</p> 	<p><b>Expanding your range</b></p> <p>Range extender: KX-THA15</p> 
<p>Cordless video camera station: KX-THA16 (Large color display type)</p> 	

**Note:**

- The following units can be registered to a single base unit:
  - Handsets (KX-THA11/KX-THA12/KX-THA16/KX-THA17): max. 8
  - Other units (KX-THA13/KX-THA14/KX-THA15): max. 10 (including Bluetooth devices)
  - Bluetooth devices: max. 5

## Introduction

### Various features using the optional units

#### Video call

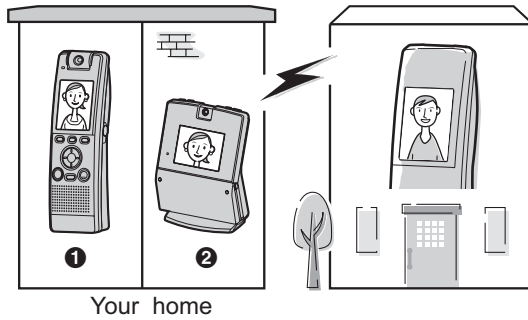

This feature allows you and the person you are talking to to see each other in real time for an outside call using the handsets. If you have additional units (1, 2), you can also make a video call during an intercom call.

- 1 KX-THA12/KX-THA17
- 2 KX-THA16

#### View monitor

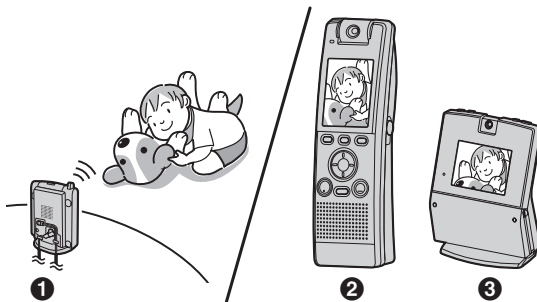

This feature allows you to view the room where the cordless camera (1) is located from the units (2, 3). You can also view the room between the units (2, 3).

- 1 KX-THA13
- 2 KX-THA12/KX-THA17
- 3 KX-THA16

#### Cellular convergence (compatible with Bluetooth)

Your cellular phone



This feature allows you to save on phone charges by using your unit (1, 2, 3 and the base unit) to make or answer calls using the cellular line of a connected Bluetooth-compatible cellular phone.

- 1 KX-THA11
- 2 KX-THA12/KX-THA17
- 3 KX-THA16



## Introduction

### Data link feature

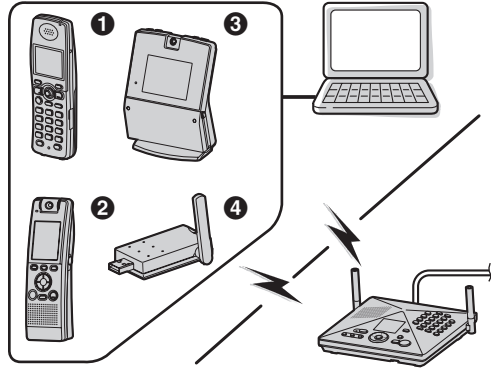

This feature allows you to access another computer by connecting the units (1, 2, 3) or a USB adaptor (4) to your computer.

- 1 KX-THA11
- 2 KX-THA12/KX-THA17
- 3 KX-THA16
- 4 KX-THA14

### Range extension

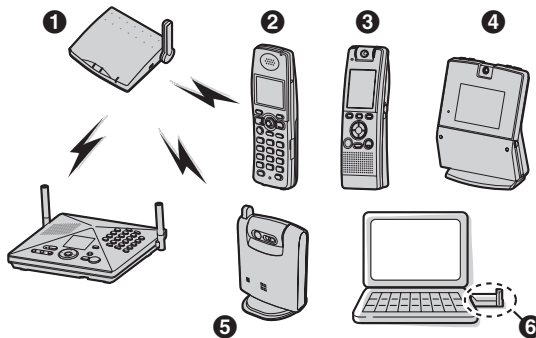

By using a range extender (1), you can extend the usage area of the units (2, 3, 4, 5, 6).

- 1 KX-THA15
- 2 KX-THA11
- 3 KX-THA12/KX-THA17
- 4 KX-THA16
- 5 KX-THA13
- 6 KX-THA14

### Video call using TV

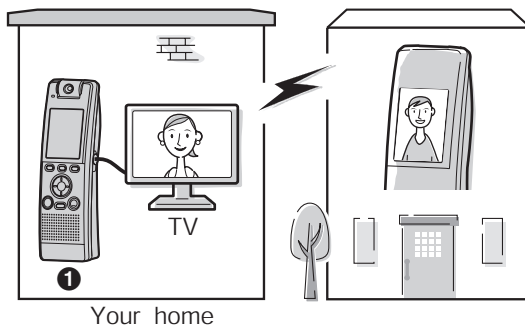

This feature allows you to use your TV to see the other person during a video call.

- 1 KX-THA17

## Introduction

### Important safety instructions

When using the product, basic safety precautions should always be followed to reduce the risk of fire, electric shock, or personal injury.

1. Read and understand all instructions.
2. Follow all warnings and instructions marked on the product.
3. Unplug the product from power outlets before cleaning. Do not use liquid or aerosol cleaners. Use a moist cloth for cleaning.
4. Do not use the product near water, for example near a bathtub, wash bowl, kitchen sink, etc.
5. Place the product securely on a stable surface. Serious damage and/or injury may result if the product falls.
6. Do not cover slots and openings on the product. They are provided for ventilation and protection against overheating. Never place the product near radiators, or in a place where proper ventilation is not provided.
7. Use only the power source marked on the product. If you are not sure of the type of power supplied to your home, consult your dealer or local power company.
8. Do not place objects on the power cord. Install the product where no one can step or trip on the cord.
9. Do not overload power outlets and extension cords. This can result in the risk of fire or electric shock.
10. Never push any objects through slots in the product. This may result in the risk of fire or electric shock. Never spill any liquid on the product.
11. To reduce the risk of electric shock, do not disassemble the product. Take the product to an authorized service center when service is required. Opening or removing covers may expose you to dangerous voltages or other risks.

Incorrect reassembly can cause electric shock when the product is subsequently used.

12. Unplug the product from power outlets and refer servicing to an authorized service center when the following conditions occur:
  - A. When the power cord is damaged or frayed.
  - B. If liquid has been spilled into the product.
  - C. If the product has been exposed to rain or water.
  - D. If the product does not work normally by following the operating instructions. Adjust only controls covered by the operating instructions. Improper adjustment may require extensive work by an authorized service center.
  - E. If the product has been dropped or physically damaged.
  - F. If the product exhibits a distinct change in performance.
13. During thunderstorms, avoid using telephones except cordless types. There may be a remote risk of an electric shock from lightning.
14. Do not use the product to report a gas leak, when in the vicinity of the leak.

### SAVE THESE INSTRUCTIONS

#### CAUTION:

##### Installation

- Never install telephone wiring during a lightning storm.
- Never install telephone jacks in wet locations unless the jack is specifically designed for wet locations.
- Never touch uninsulated telephone wires or terminals unless the telephone line has been disconnected at the network interface.
- Use caution when installing or modifying telephone lines.

## Introduction

- Do not touch the plug with wet hands.
- The AC adaptor is used as the main disconnect device. Ensure that the AC outlet is installed near the product and is easily accessible.

### Battery

To reduce the risk of fire or injury to persons, read and follow these instructions.

- Use only the battery(ies) specified.
- Do not dispose of the battery(ies) in a fire. They may explode. Check with local waste management codes for special disposal instructions.
- Do not open or mutilate the battery(ies). Released electrolyte is corrosive and may cause burns or injury to the eyes or skin. The electrolyte may be toxic if swallowed.
- Exercise care when handling the battery(ies). Do not allow conductive materials such as rings, bracelets or keys to touch the battery(ies), otherwise a short circuit may cause the battery(ies) and/or the conductive material to overheat and cause burns.
- Charge the battery(ies) provided, or identified for use with the product only, in accordance with the instructions and limitations specified in this manual.

### WARNING:

- To prevent the risk of fire or electrical shock, do not expose the product to rain or any type of moisture.
- Unplug the product from power outlets if it emits smoke, an abnormal smell, or makes an unusual noise. These conditions can cause fire or electric shock. Confirm that smoke has stopped and contact the Panasonic Call Center at 1-800-211-PANA (7262).

### Medical

- Consult the manufacturer of any personal medical devices, such as

pacemakers or hearing aids, to determine if they are adequately shielded from external RF (radio frequency) energy. (The product operates in the frequency range of 2.4 GHz to 2.48 GHz, and the power output is 125 mW (max.)) Do not use the product in health care facilities if any regulations posted in the area instruct you not to do so. Hospitals or health care facilities may be using equipment that could be sensitive to external RF (radio frequency) energy.

## Introduction

### For best performance

#### Base unit location/noise

The base unit and other compatible Panasonic units use radio waves to communicate with each other.

For maximum distance and noise-free operation, we recommend the following:

- Placing the product away from electrical appliances.
- Placing the base unit in a HIGH and CENTRAL location with no obstructions such as walls.
- Raising the antennas vertically.
- If you use the handset near a microwave oven which is being used, noise may be heard. Move away from the microwave oven and closer to the base unit.
- If you use the handset near another cordless phone's base unit, noise may be heard. Move away from the other cordless phone's base unit and closer to your base unit.

#### Environment

- Keep the product away from electrical noise generating devices, such as fluorescent lamps and motors.
- The product should be kept free from excessive smoke, dust, high temperature, and vibration.
- The product should not be exposed to direct sunlight.
- Do not place heavy objects on top of the product.
- When you leave the product unused for a long period of time, unplug the product from the power outlet.
- The product should be kept away from heat sources such as heaters, kitchen stoves, etc. It should not be placed in rooms where the temperature is less than 5 °C (41 °F) or greater than 40 °C

(104 °F). Damp basements should also be avoided.

- The maximum calling distance may be shortened when the product is used in the following places: Near obstacles such as hills, tunnels, underground, near metal objects such as wire fences, etc.
- Operating near 2.4 GHz electrical appliances may cause interference. Move away from the electrical appliances.

#### Routine care

- Wipe the outer surface of the product with a soft moist cloth. Do not use benzine, thinner, or any abrasive powder.

## Preparation

### Setting up the base unit

#### Overview

- 1** Connect the AC adaptor.
- 2** Connect the telephone line cord.  
Refer to one of the following methods depending on your situation.
  - To connect to a 2-line telephone jack: page 14
  - To connect to 2 single-line telephone jacks: page 14
  - To connect to a single-line telephone jack: page 14
  - If you subscribe to a DSL service and
    - To connect to a 2-line telephone jack: page 15
    - To connect to 2 single-line telephone jacks: page 15
- 3** To connect to your LAN, see page 69.

#### Connecting the AC adaptor

Connect the AC adaptor, then raise the antennas.

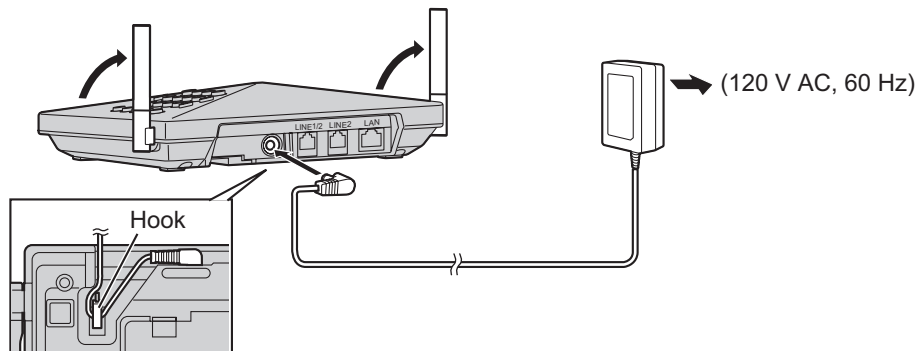

#### Note:

- Use only the included Panasonic AC adaptor PQLV205.
- The AC adaptor must remain connected at all times. (It is normal for the adaptor to feel warm during use.)
- The AC adaptor should be connected to a vertically oriented or floor-mounted AC outlet. Do not connect the AC adaptor to a ceiling-mounted AC outlet, as the weight of the adaptor may cause it to become disconnected.
- The unit will not work during a power failure. We recommend connecting a standard telephone to the same telephone line or to the same telephone jack using a Panasonic T-adaptor (page 6).

## Preparation

### Connecting the telephone line cord

#### To connect to a 2-line telephone jack

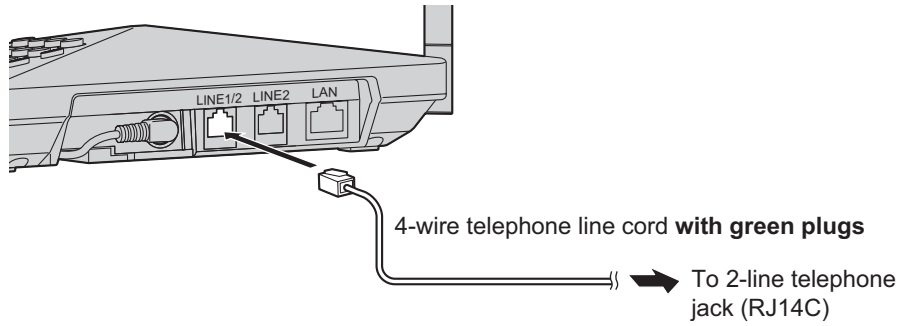

#### To connect to 2 single-line telephone jacks

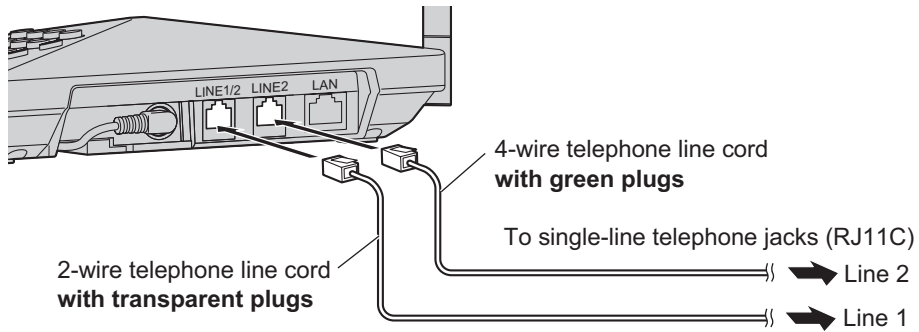

#### To connect to a single-line telephone jack

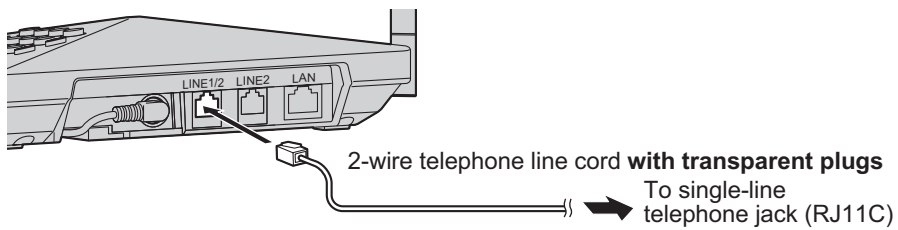

## Preparation

### If you subscribe to a DSL service

- Please attach a noise filter (contact your DSL provider) to the telephone line between the base unit and the telephone line jack in the event of the following:
  - Noise is heard during conversations.
  - Caller ID features (page 34) do not function properly.

### To connect to a 2-line telephone jack

For this connection, please purchase a Panasonic 2-line splitter (page 6).  
 Example: DSL line is LINE 2

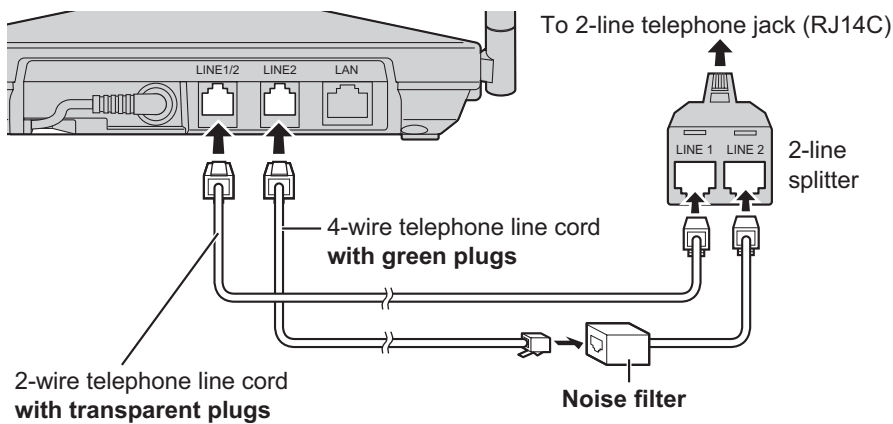

### To connect to 2 single-line telephone jacks

Example: DSL line is LINE 2

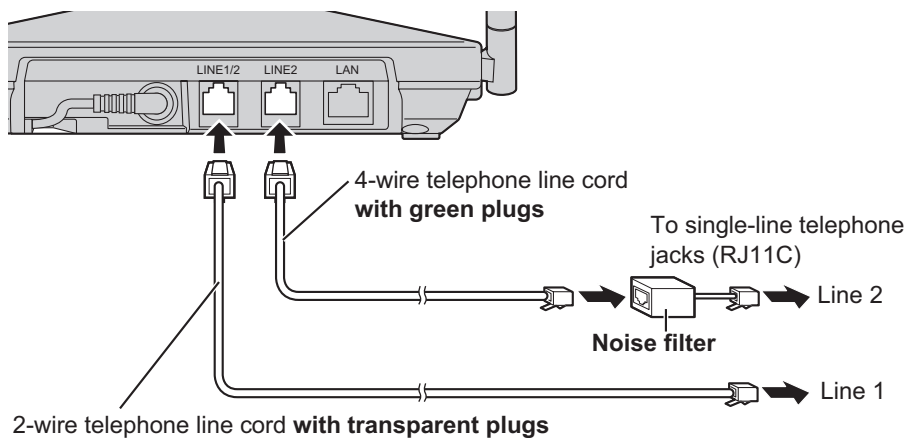

## Preparation

## Controls

### Base unit

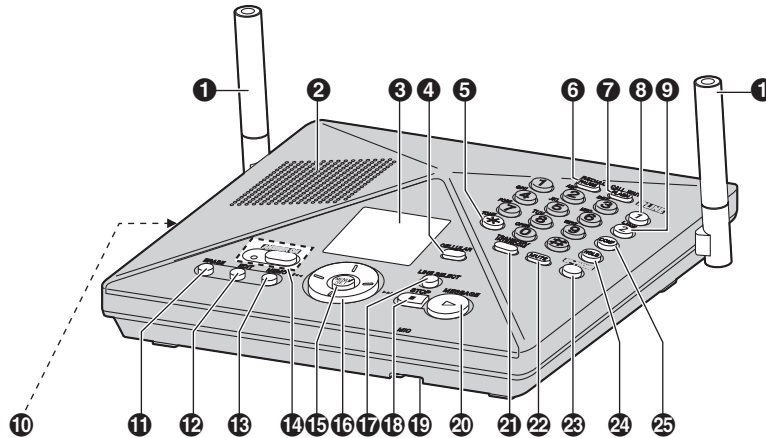

- |                              |  |
|------------------------------|--|
| <b>1</b> Antenna             | <b>14</b> [ANSWER ON]<br>ANSWER ON indicator |
| <b>2</b> Speaker             | <b>15</b> [MENU] [SET]                       |
| <b>3</b> Display             | <b>16</b> Navigator key                      |
| <b>4</b> [CELLULAR]          | <b>17</b> [LINE SELECT]                      |
| <b>5</b> [*] (TONE)          | <b>18</b> [STOP]                             |
| <b>6</b> [PAUSE] [REDIAL]    | <b>19</b> MIC (Microphone)                   |
| <b>7</b> [FLASH] [CALL WAIT] | <b>20</b> [MESSAGE]                          |
| <b>8</b> [LINE1]             | <b>21</b> [TRANSFER] [INTERCOM]              |
| <b>9</b> [LINE2]             | <b>22</b> [MUTE]                             |
| <b>10</b> USB port*          | <b>23</b> [SP-PHONE] (Speakerphone)          |
| <b>11</b> [ERASE]            | <b>24</b> [HOLD]                             |
| <b>12</b> [EDIT]             | <b>25</b> [CONF] (Conference)                |
| <b>13</b> [MEMO]             |  |

\* Connecting the USB cable to the USB port, you can:

- use MULTI TALK V USB Utility with your computer.
- access to Internet (broadband or dial up) with your computer.
- view the images through the cordless camera (sold separately) with your computer.
- update your phone's firmware.



## Preparation

### Handset

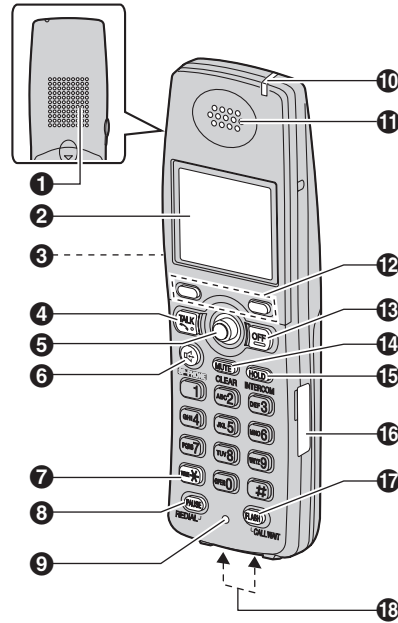

- |                           |                                       |
|---------------------------|---------------------------------------|
| 1 Speaker                 | 10 Ringer indicator/Message indicator |
| 2 Display                 | 11 Receiver                           |
| 3 Headset jack/Audio jack | 12 Soft keys                          |
| 4 [↵] (Talk)              | 13 [OFF]                              |
| 5 Joystick                | 14 [MUTE] [CLEAR]                     |
| 6 [↵] (SP-PHONE)          | 15 [HOLD] [INTERCOM]                  |
| 7 [*] (TONE)              | 16 USB port*                          |
| 8 [PAUSE] [REDIAL]        | 17 [FLASH] [CALL WAIT]                |
| 9 Microphone              | 18 Charge contacts                    |

• For usage of USB port, see page 18.

#### Using the joystick

The handset joystick can be used to navigate through menus and to select items shown on the display, by pushing it up, down, left, or right.

It can also be used to select the center soft key icon (page 21), by pressing down on the center of the joystick.

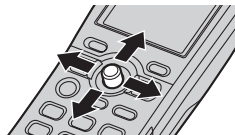

## FCC and other information

This equipment complies with Part 68 of the FCC rules and the requirements adopted by the ACTA. On the bottom of this equipment is a label that contains, among other information, a product identifier in the format US:ACJ-----.

If requested, this number must be provided to the telephone company.

- Registration No  
.....(found on the bottom of the unit)
- Ringer Equivalence No.  
(REN).....0.2B

A plug and jack used to connect this equipment to the premises wiring and telephone network must comply with the applicable FCC Part 68 rules and requirements adopted by the ACTA. A compliant telephone cord and modular plug is provided with the product. It is designed to be connected to a compatible modular jack that is also compliant.

The REN is used to determine the number of devices that may be connected to a telephone line. Excessive RENs on a telephone line may result in the devices not ringing in response to an incoming call. In most but not all areas, the sum of RENs should not exceed five (5.0). To be certain of the number of devices that may be connected to a line, as determined by the total RENs, contact the local telephone company. For products approved after July 23, 2001, the REN for the product is part of the product identifier that has the format US:AAAEQ##TXXXX. The digits represented by ## are the REN without a decimal point (e.g., 03 is a REN of 0.3).

If this equipment causes harm to the telephone network, the telephone company will notify you in advance that temporary discontinuance of service may be required. But if advance notice isn't practical, the telephone company will

notify the customer as soon as possible. Also, you will be advised of your right to file a complaint with the FCC if you believe it is necessary.

The telephone company may make changes in its facilities, equipment, operations or procedures that could affect the operation of the equipment. If this happens the telephone company will provide advance notice in order for you to make necessary modifications to maintain uninterrupted service.

If trouble is experienced with this equipment, for repair or warranty information, please contact a Factory Servicenter or other Authorized Servicer. If the equipment is causing harm to the telephone network, the telephone company may request that you disconnect the equipment until the problem is resolved.

Connection to party line service is subject to state tariffs. Contact the state public utility commission, public service commission or corporation commission for information.

If your home has specially wired alarm equipment connected to the telephone line, ensure the installation of this equipment does not disable your alarm equipment. If you have questions about what will disable alarm equipment, consult your telephone company or a qualified installer.

This equipment is hearing aid compatible as defined by the FCC in 47 CFR Section 68.316.

## Useful Information

When you hold the phone to your ear, noise might be heard in your Hearing Aid. Some Hearing Aids are not adequately shielded from external RF (radio frequency) energy. If noise occurs, use an optional headset accessory or the speakerphone option (if applicable) when using this phone. Consult with your audiologist or Hearing Aid manufacturer about the availability of Hearing Aids which provide adequate shielding to RF energy commonly emitted by digital devices.

### WHEN PROGRAMMING EMERGENCY NUMBERS AND(OR) MAKING TEST CALLS TO EMERGENCY NUMBERS:

- 1) Remain on the line and briefly explain to the dispatcher the reason for the call.
- 2) Perform such activities in the off-peak hours, such as early morning or late evenings.

The software contained in this equipment to allow user access to the network must be upgraded to recognize newly established network area codes and exchange codes as they are placed into service.

Failure to upgrade the premises systems or peripheral equipment to recognize the new codes as they are established will restrict the customer and the customer's employees from gaining access to the network and to these codes.

This device complies with Part 15 of the FCC Rules. Operation is subject to the following two conditions:

(1) This device may not cause harmful interference, and (2) this device must accept any interference received, including interference that may cause undesired operation.

Privacy of communications may not be ensured when using this phone.

### CAUTION:

Any changes or modifications not expressly approved by the party responsible for compliance could void the user's authority to operate this device.

### NOTE:

This equipment has been tested and found to comply with the limits for a Class B digital device, pursuant to Part 15 of the FCC Rules. These limits are designed to provide reasonable protection against harmful interference in a residential installation. This equipment generates, uses, and can radiate radio frequency energy and, if not installed and used in accordance with the instructions, may cause harmful interference to radio communications. However, there is no guarantee that interference will not occur in a particular installation. If this equipment does cause harmful interference to radio or television reception, which can be determined by turning the equipment off and on, the user is encouraged to try to correct the interference by one or more of the following measures:

- Reorient or relocate the receiving antenna.
- Increase the separation between the equipment and receiver.
- Connect the equipment into an outlet on a circuit different from that to which the receiver is connected.
- Consult the dealer or an experienced radio/TV technician for help.

Some cordless telephones operate at frequencies that may cause interference to nearby TVs and VCRs. To minimize or prevent such interference, the base of the cordless telephone should not be placed near or on top of a TV or VCR. If interference is experienced, move the cordless telephone further away from the TV or VCR. This will often reduce, or eliminate, interference.

## Useful Information

### FCC RF Exposure Warning:

The product complies with FCC radiation exposure limits set forth for an uncontrolled environment. To comply with FCC RF exposure requirements, the base unit must be installed and operated with its antenna located 20 cm (8 feet) or more between antenna and all person's body (excluding extremities of hands, wrist and feet). The handset may be carried and operated with only the specific provided belt-clip. Other non-tested belt-clips or similar body-worn accessories may not comply and must be avoided. The base unit and handset must not be colocated or operated in conjunction with any other antenna or transmitter.

### Responsible party:

Panasonic Corporation of North America  
One Panasonic Way,  
Secaucus, New Jersey 07094  
Phone number: 1-800-211-PANA (7262)

### FCC Warning:

To ensure compliance with FCC emissions limits, use only the included USB cable with the ferrite core when connecting the unit to a computer.

### Notice

- This cordless telephone is designed for use in the United States of America. Sale or use of this product in other countries may violate local laws.
- Ce téléphone sans fil est conçu pour être utilisé aux États-Unis d'Amérique. La vente ou l'emploi de cet appareil dans certains autres pays peut constituer une infraction à la législation locale.
- Este teléfono inalámbrico fue elaborado para uso en los Estados Unidos de América. La venta o el empleo de este producto en ciertos países puede constituir violación de la legislación local.
- このコードレス電話機は、日本国外での使用を目的として設計されており、日本国内での使用は法律違反となります。従って、当社では日本国内においては原則として修理などのサービスは致しかねます。

## Useful Information

# Specifications

### General

<b>Operating environment</b>	5 °C – 40 °C (41 °F – 104 °F)
<b>Frequency</b>	2.4 GHz – 2.48 GHz
<b>Bluetooth compliance</b>	Bluetooth specification 1.1 and 1.2

### Base unit

<b>Dimensions</b>	Approx. height 48 mm x width 205 mm x depth 182 mm (1 <sup>7</sup> / <sub>8</sub> inches x 8 <sup>1</sup> / <sub>16</sub> inches x 7 <sup>5</sup> / <sub>32</sub> inches)
<b>Mass (Weight)</b>	Approx. 530 g (1.17 lb.)
<b>Power consumption</b>	Standby: Approx. 2.6 W Maximum: Approx. 5.5 W
<b>TX power</b>	125 mW (max.)
<b>Power supply</b>	AC adaptor (120 V AC, 60 Hz)

### Handset

<b>Dimensions</b>	Approx. height 171 mm x width 51 mm x depth 51 mm (6 <sup>11</sup> / <sub>16</sub> inches x 2 inches x 2 inches)
<b>Mass (Weight)</b>	Approx. 220 g (0.49 lb.)
<b>Power consumption</b>	Standby: Approx. 2.6 W Maximum: Approx. 5.5 W
<b>TX power</b>	125 mW (max.)
<b>Power supply</b>	Ni-MH battery (3.6 V, 830 mAh)

### Charger

<b>Dimensions</b>	Approx. height 64 mm x width 88 mm x depth 99 mm (2 <sup>17</sup> / <sub>32</sub> inches x 3 <sup>15</sup> / <sub>32</sub> inches x 3 <sup>29</sup> / <sub>32</sub> inches)
<b>Mass (Weight)</b>	Approx. 120 g (0.26 lb.)
<b>Power consumption</b>	Standby: Approx. 1.0 W Maximum: Approx. 4.0 W
<b>Power supply</b>	AC adaptor (120 V AC, 60 Hz)

### Note:

- Design and specifications are subject to change without notice.
- The illustrations in these instructions may vary slightly from the actual product.

## Useful Information

### Customer services

#### **Customer Services Directory**

Obtain Product Information and Operating Assistance; locate your nearest Dealer or Servicenter; purchase Parts and Accessories; or make Customer Service and Literature requests by visiting our Web Site at:

**<http://www.panasonic.com/consumersupport>**

or, contact us via the web at:

**<http://www.panasonic.com/contactinfo>**

You may also contact us directly at: 1-800-211-PANA (7262),  
Monday-Friday 9 am-9 pm; Saturday-Sunday 10 am-7 pm, EST.

TTY users (hearing or speech impaired users) can call 1-877-833-8855.

#### **Accessory Purchases**

Purchase Parts, Accessories and Instruction Books online for all Panasonic Products by visiting our Web Site at:

**<http://www.pasc.panasonic.com>**

or, send your request by E-mail to:

**[npcparts@us.panasonic.com](mailto:npcparts@us.panasonic.com)**

You may also contact us directly at:  
1-800-332-5368 (Phone) 1-800-237-9080 (Fax Only)  
(Monday - Friday 9 am to 8 pm, EST.)

Panasonic Services Company  
20421 84th Avenue South, Kent, WA 98032  
(We Accept Visa, MasterCard, Discover Card, American Express, and  
Personal Checks)

TTY users (hearing or speech impaired users) can call 1-866-605-1277.

#### **Service in Puerto Rico**

Panasonic Puerto Rico, Inc.  
San Gabriel Industrial Park, Ave. 65 de Infantería, Km. 9.5,  
Carolina, Puerto Rico 00985  
Phone (787)750-4300, Fax (787)768-2910