

# Panasonic<sup>®</sup>

## Operating Instructions

### DECT 6.0 Portable Station

---

Model No. **KX-WT125/KX-WT126**

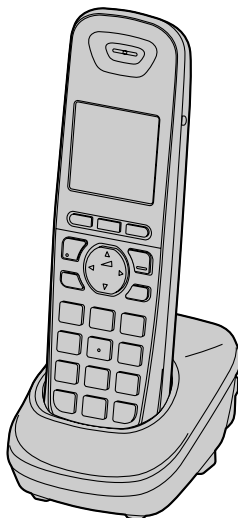

**Thank you for purchasing a Panasonic DECT 6.0 Portable Station.**

**Please read this manual carefully before using this product and save this manual for future use.**

**Please use only the batteries provided and charge the batteries for about 7 hours before using the handset for the first time.**

## Table of Contents







<b>Before Initial Use</b> .....	<b>4</b>
<b>Accessories (included)</b> .....	<b>4</b>
<b>Installation</b> .....	<b>5</b>
Battery Installation .....	5
Charger Connection .....	5
Charging the Batteries .....	6
Charger Wall Mounting .....	6
Attaching the Belt Clip .....	7
<b>Before Operating the Handset</b> .....	<b>8</b>
<b>Location of Controls</b> .....	<b>8</b>
Key Lock .....	10
Silent Mode .....	10
Advanced Voice Clarity .....	10
<b>Selecting the Display Language</b> .....	<b>11</b>
<b>Editing the Standby Display Name</b> .....	<b>12</b>
<b>Editing the Names of the Flexible CO Keys</b> .....	<b>13</b>
<b>Editing the Names of the Soft Keys for the Flexible CO Keys</b> .....	<b>14</b>
<b>Adjusting the Ringer Volume</b> .....	<b>15</b>
<b>Adjusting the Ringer Volume or Turning the Ringer off while Ringing</b> .....	<b>15</b>
<b>Changing the Vibrate Setting (KX-WT126 only)</b> .....	<b>16</b>
<b>Adjusting the Receiver/Speaker/Headset Volume</b> .....	<b>16</b>
<b>Display</b> .....	<b>17</b>
<b>Soft Keys</b> .....	<b>18</b>
<b>Operation Outline</b> .....	<b>19</b>
<b>Function Keys</b> .....	<b>20</b>
<b>Flexible CO Keys</b> .....	<b>22</b>
<b>Operation</b> .....	<b>23</b>
<b>Making Calls</b> .....	<b>23</b>
Searching for an item stored in the Phonebook .....	27
<b>Receiving Calls</b> .....	<b>30</b>
Caller ID .....	31
<b>During a Conversation</b> .....	<b>32</b>
<b>Useful Features</b> .....	<b>34</b>
<b>Making Use of the Voice Mail Service</b> .....	<b>39</b>
<b>Using the Handset Phonebook</b> .....	<b>41</b>
<b>Handset Phonebook</b> .....	<b>41</b>
Private Ring .....	41
<b>Storing an Item in the Handset Phonebook</b> .....	<b>42</b>
Storing a New Item .....	42
Editing a Stored Item .....	43
Storing an Item Using Predialing .....	45
Storing an Item Using the Outgoing Call Log .....	46
Storing an Item Using the Incoming Call Log .....	47
Storing an Item Using the PBX System/Extension Phonebook .....	48

Editing Category Names .....	49
<b>Assigning Hot Keys .....</b>	<b>50</b>
<b>Entering Characters .....</b>	<b>51</b>
Character Mode Table .....	52
<b>Locking the Handset Phonebook .....</b>	<b>53</b>
Locking/Unlocking the Handset Phonebook .....	53
Unlocking the Handset Phonebook Temporarily .....	53
<b>Deleting Stored Items .....</b>	<b>54</b>
<b>Deleting Stored Items in Handset Phonebook/Hot Key Dial/Outgoing Call</b>	
<b>Log/Incoming Call Log .....</b>	<b>54</b>
Handset Phonebook .....	54
Hot Key Dial .....	55
Outgoing Call Log .....	56
Incoming Call Log .....	56
<b>Configuring Handset Settings .....</b>	<b>57</b>
<b>Changing the Initial Settings .....</b>	<b>57</b>
Handset Setting Menu Layout .....	58
Memo Alarm Setting .....	65
<b>Troubleshooting and Error Messages .....</b>	<b>68</b>
<b>Troubleshooting .....</b>	<b>68</b>
<b>Error Messages .....</b>	<b>70</b>
<b>Important Information .....</b>	<b>71</b>
<b>Battery Information .....</b>	<b>71</b>
<b>Important Safety Instructions .....</b>	<b>72</b>
<b>For Your Safety .....</b>	<b>72</b>
<b>For Best Performance .....</b>	<b>74</b>
<b>Security Information .....</b>	<b>75</b>
<b>FCC and Other Information .....</b>	<b>76</b>
Customer Information .....	77

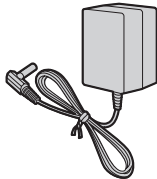
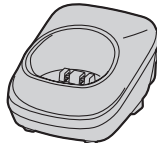
## Before Initial Use

Please read "Important Information" on page 71 before using. Read and understand all instructions.

### Accessories (included)

AC adaptor: 1  [Part No.] PQLV219		
Charger: 1  [Part No.]	Battery: 2  [Part No.] HHR-65AAAB	Belt Clip: 1  [Part No.]
Belt Clip Holder: 1  [Part No.]	Battery Cover: 1  [Part No.]	Screws and Washers: 2  [Part No.]

- To order accessories, call toll free **1-800-332-5368**.

---

## Installation

---

### Battery Installation

Open the battery cover, insert the batteries, and close the cover as indicated below.

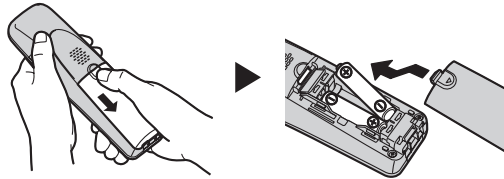

---

### Charger Connection

Connect the AC adaptor to the charger.

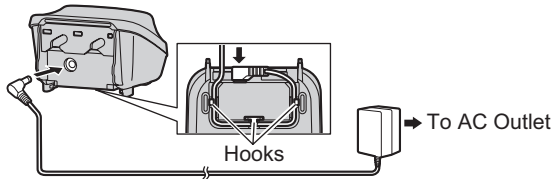

- The AC adaptor should be connected to a vertically oriented or floor-mounted AC outlet. Do not connect the AC adaptor to a ceiling-mounted AC outlet, as the weight of the adaptor may cause it to become disconnected.
- Fasten the AC adaptor cord to the cord holder.
- Use only the included Panasonic AC adaptor. (See "Accessories (included)" on page 4.)

### **WARNING**

- To reduce the risk of fire or electric shock, do not overload AC outlets and extension cords.
- Do not bundle the charger's AC adaptor cord with the power cords of machines located nearby.
- Completely insert the AC adaptor/power plug into the AC outlet. Failure to do so may cause electric shock and/or excessive heat resulting in a fire.

## Before Initial Use

---

### Charging the Batteries

At the time of shipment, the batteries are not charged. **Please charge the batteries for about 7 hours before using the handset for the first time.**



- When the batteries are fully charged, the charge indicator goes off and "Fully charged" is displayed. For more information, see "Battery Information" on page 71.
- It is normal for the handset and charger to feel warm while the batteries are charging.
- Keep devices sensitive to magnetic fields away from the charger.
- Use only the included charger.

---

### Charger Wall Mounting

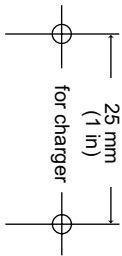

1. Install the two screws in the wall, spacing them 25 mm (1 in) apart.

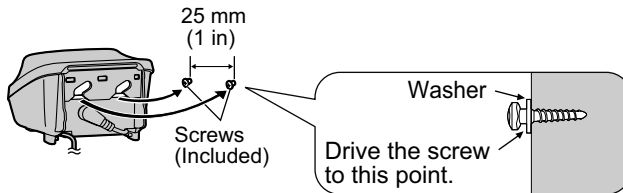

2. Mount the charger securely on the wall.

- Please copy this page and use as a reference for wall mounting. Make sure to set the print size to correspond with the size of this page. If the dimension of the paper output still deviates slightly from the measurement indicated here, use the measurement indicated here.
- When mounting the charger, ensure that the correct screws are used for the type of wall.
- Make sure that the wall that the charger will be attached to is strong enough to support the total weight of the handset and charger (approx. 190 g). If not, it is necessary for the wall to be reinforced.
- When this product is no longer in use, make sure to detach it from the wall.
- When inserting screws, avoid pipes and electrical cables, etc, that may be present/buried.
- The screw heads should not be flush to the wall.
- Certain types of wall may require plugs to be anchored in the wall before the screws are inserted.

## **Attaching the Belt Clip**

You can attach the handset to your belt by following the steps below.

### **[To attach]**

- 1 Insert the clip into the designated notches in the handset.

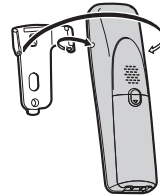

- 2 Slide the clip into the holder until it clicks.



### **[To remove]**

- 1 Make sure to turn the handset 180° when you take it off.

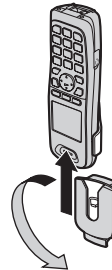

- 2 Remove the belt clip.

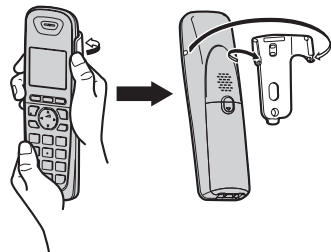

### Location of Controls

The headset is an optional accessory.

Please use only a Panasonic headset below.  
KX-TCA93/KX-TCA94/  
KX-TCA95/KX-TCA400/  
KX-TCA430

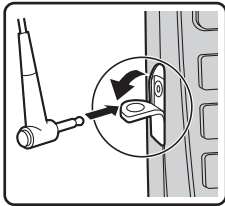

Open the cover.

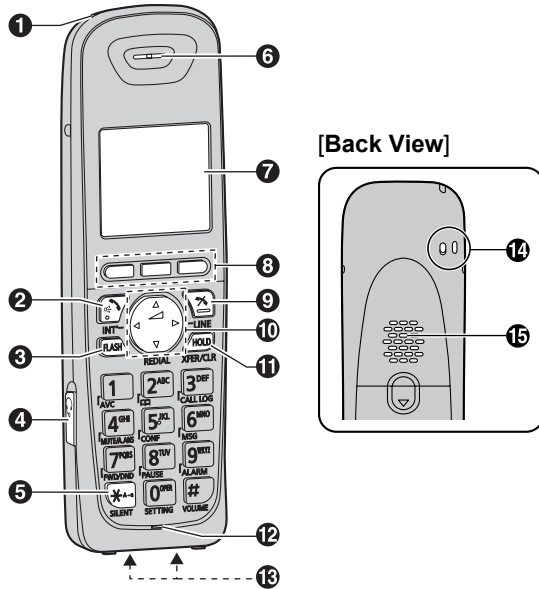

**1 Ringer/Charge Indicator**

**2 TALK/SP-PHONE (Speakerphone) Key**

Used to make or answer calls, or toggle between the Receiver/Hands-free\*1 mode during a conversation.

**3 FLASH Key**

Used to disconnect the current call and make another call without hanging up.

**4 Headset Jack**

**5 Silent Mode Key**

Used to turn Silent Mode on or off when pressed for more than 2 seconds in standby mode. For more information, refer to "Silent Mode" on page 10.

**6 Receiver**

**7 Display**

Refer to "Display" on page 17.

**8 Soft Keys**

The handset features 3 soft keys. By pressing a soft key, you can select the feature shown directly above it on the display.

**9 CANCEL Key**

Used to end calls or exit Function mode.



### **10 Navigator Key**

Used to adjust the ringer/receiver volume or move the cursor to select an item. In standby mode, pressing each arrow enables the following functions:

UP → Opens the Phonebook Menu.

DOWN → Displays the Outgoing Call Log.

Left → Makes or answers intercom calls.

Right → Displays a list of flexible CO keys.

### **11 HOLD/TRANSFER/CLEAR Key**

Used to place a call on hold or transfer a call to another party. It is also used to clear digits or characters. For more information on switching between HOLD and TRANSFER, refer to "Key Option" on page 61.

### **12 Microphone**

### **13 Charge Contacts**

### **14 Strap Holes**

Used to attach phone straps and similar items.



### **15 Speaker**

\*1 You can talk with the other party alternately through the speaker in a quiet room. During a conversation using a headset, Hands-free mode does not work.

## Before Operating the Handset



### Key Lock

You can lock all keys while the handset is in standby mode.

 Press the <b>center soft key</b> for more than 2 seconds to lock/unlock.	<b>[Display Icon]</b> <b>Unlocked</b> <b>Locked</b>  
---	---

### Silent Mode

Silent Mode turns off the ringer and sets the handset to vibrate\*<sup>1</sup> when calls are received. This can be useful in situations where you do not want to be disturbed, such as during a meeting.

Press  for more than 2 seconds to set/cancel the Silent Mode.	<b>[Display Icon]</b> <b>Silent Mode</b> 
--	--

When Silent Mode is active, the microphone's sensitivity is increased, and the following features are turned off automatically, regardless of their settings.

- Ringer Volume
- Ring On Charger
- Auto Answer
- Key Tone
- Range Alarm
- Low Battery Alarm





• If you set the handset on the charger during Silent Mode, the handset will not vibrate.\*<sup>2</sup>

\*<sup>1</sup> The vibrate feature is available only for the KX-WT126.

\*<sup>2</sup> Please note that if you set the handset on the charger while receiving an incoming call, vibration will stop. Once the vibration stops, the handset will not vibrate again for that call, even if the handset is lifted up again. (If Quick Answer is set, lifting up the handset will answer the call.)

### Advanced Voice Clarity

When this feature is enabled, clear conversation is provided on both the sending side and the receiving side. It is useful in noisy environments such as warehouses, manufacturing plants, restaurants, and garages.

	▶		▶		▶	
Press the <b>center soft key</b> .		Select "1:Voice Clarity".		Press the <b>center soft key</b> .		Select "On".

## Selecting the Display Language

You can select the language displayed on your handset.

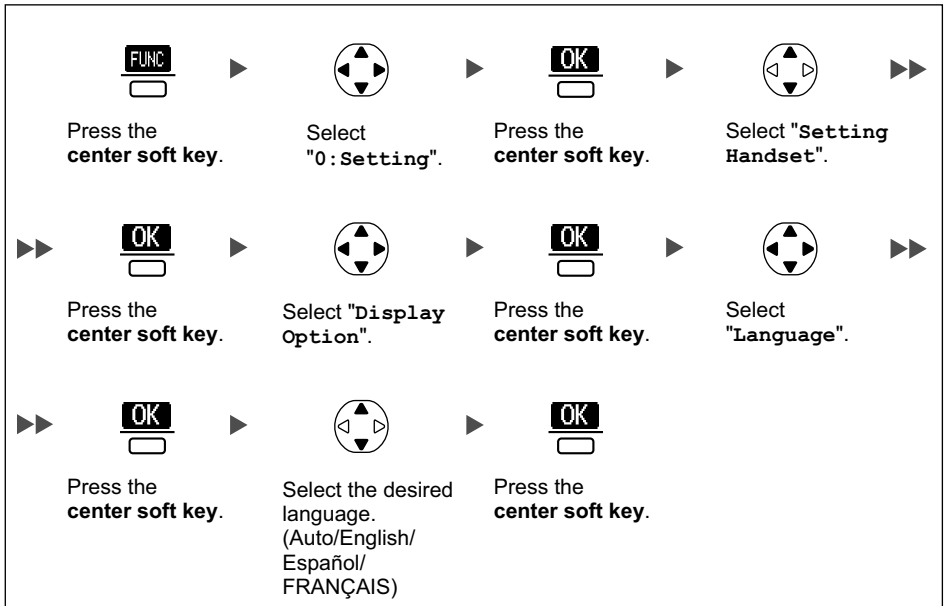

- When set to "Auto", the language settings of the PBX will be used.
- The display language of both the handset and PBX can be selected, and both should be set to the same language. For more information, refer to the user documentation for your PBX.

## Editing the Standby Display Name

You can edit the name displayed when the handset is in standby mode.

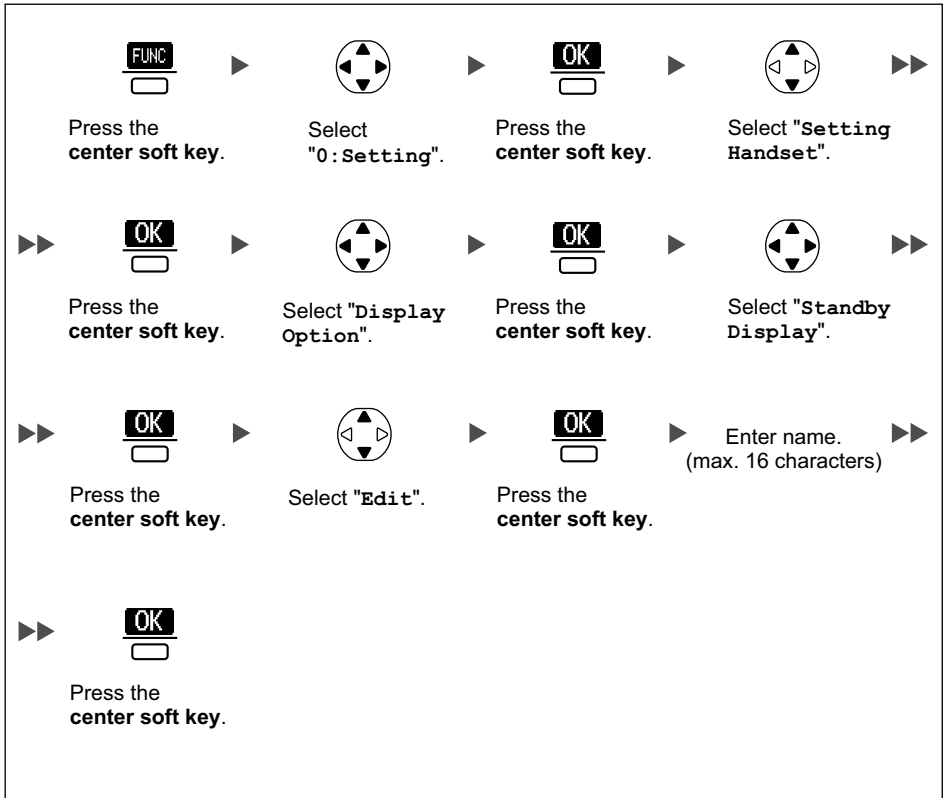

- To enter characters, see page 51.

## Editing the Names of the Flexible CO Keys

You can edit a name for each Flexible CO Key of the handset.

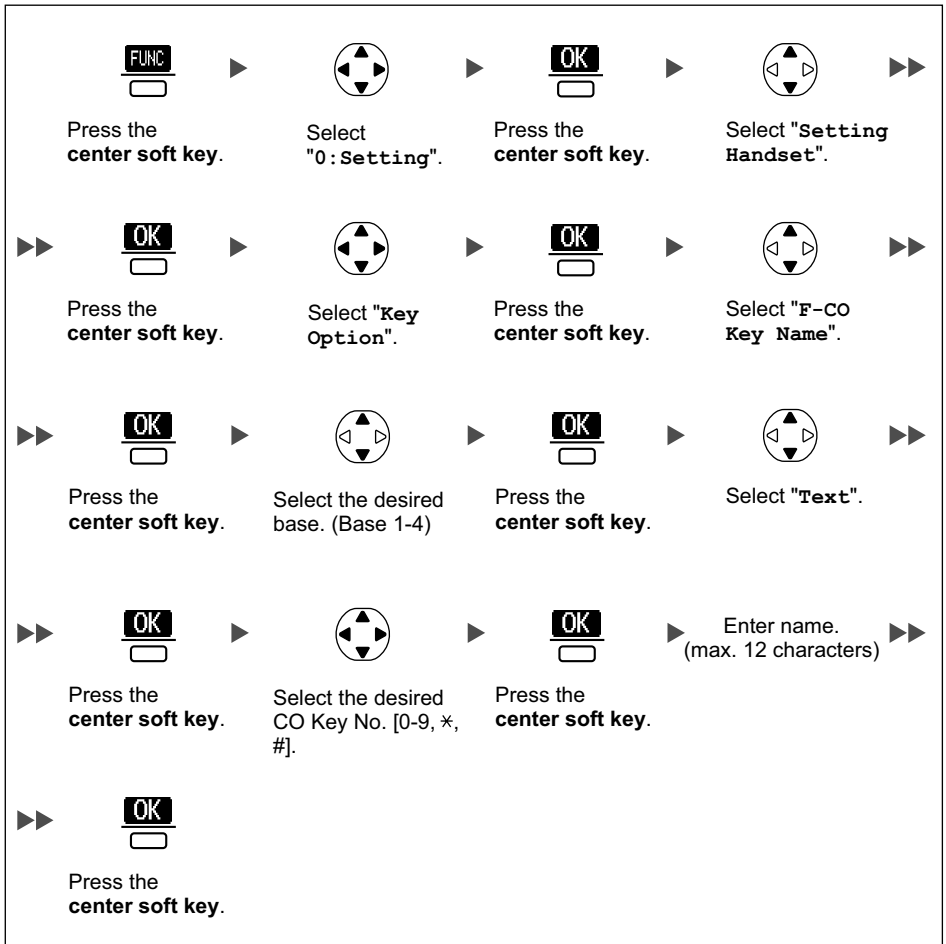

- To enter characters, see page 51.

## Editing the Names of the Soft Keys for the Flexible CO Keys

You can edit the name of the Soft Key for each Flexible CO Key of the handset.

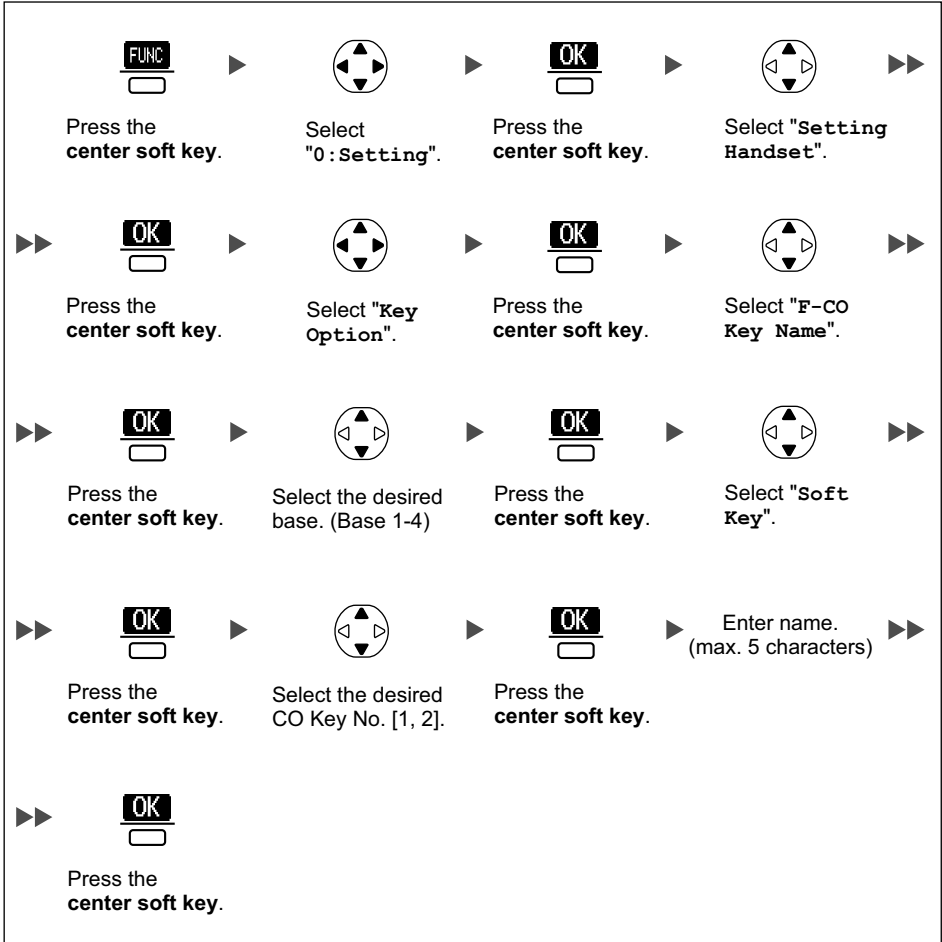

- To enter characters, see page 51.

## Adjusting the Ringer Volume

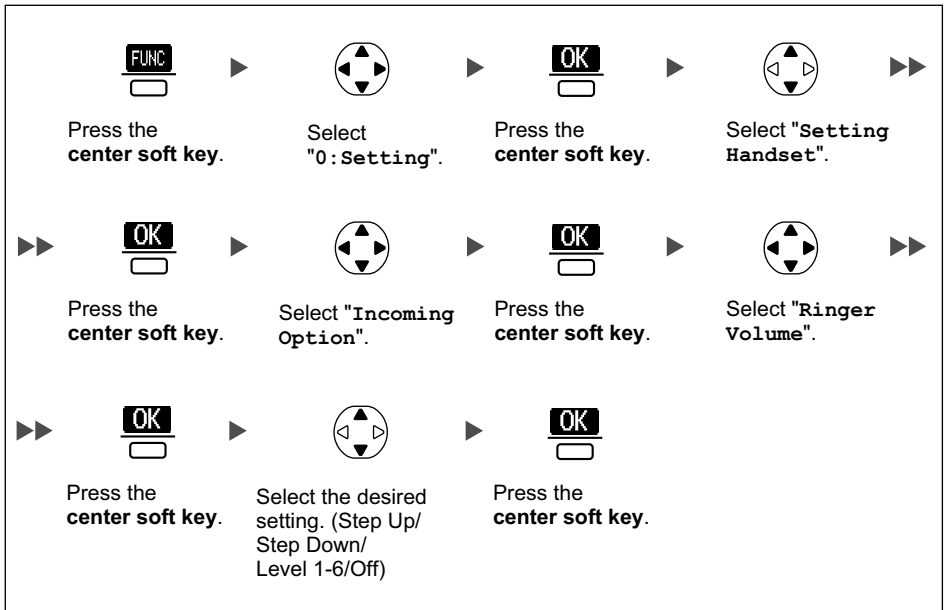

- To set the ringer pattern, see "Incoming Option" on page 60.

## Adjusting the Ringer Volume or Turning the Ringer off while Ringing

*While receiving a call*

[To adjust the ringer volume]



Press **Up** or **Down** to adjust the volume. \*1

[To turn the ringer off]



Press the **center soft key**.

OR



Press **CANCEL**.

\*1 The adjusted volume level will also be used for subsequent calls.

## Before Operating the Handset

- If you attach the headset while receiving an incoming call, the ring from the handset does not switch to the headset. If you attach the headset before receiving an incoming call, and headset ringer is set to "On", a tone will be heard from the headset. If Vibrate is set to on (KX-WT126 only), the handset will vibrate whether a headset is attached or not.

## Changing the Vibrate Setting (KX-WT126 only)

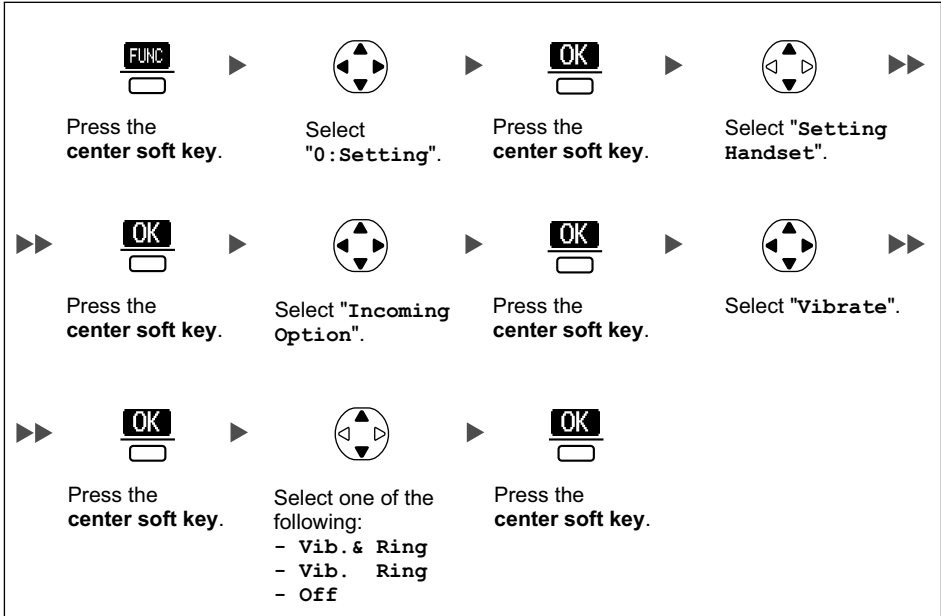

- To set Vibrate only, without ringing, select "Vib. & Ring" and set the Ringer Volume to off, or turn Silent Mode on. (See page 10, 15.)

## Adjusting the Receiver/Speaker/Headset Volume

*During a conversation*



Press **Up** or **Down** to adjust the volume.

(Receiver Volume—Level 1-4, Speaker Volume—Level 1-6, Headset Volume—Level 1-4)



## Display

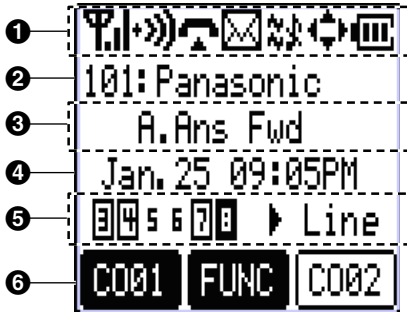

### 1 Pictograph

	Within range of a Cell Station (CS)		Silent Mode (See page 10.)
	Out of range		Navigation Key Guidance
	Intercom Indicator	<b>Battery Indicator</b> <sup>*1</sup>	
	Off-hook Status		Full
	Message Waiting		Low
	Vibrate (See page 16.)		Needs to be charged.
	Ringer Volume Off (See page 15.)		

### 2 Extension Number and Name

To edit the standby display name, see page 12.

### 3 Handset Status Information

<b>A. Ans</b>	Auto Answer
<b>Fwd</b>	Call Forwarding (See page 34.)
<b>DND</b>	Do Not Disturb (See page 34.)

### 4 Date and Time Display

If there are missed calls, that information will be displayed instead of the date and time.

### 5 Flexible CO Key Status

For more information, see page 22.



























### 6 Soft Keys

For more information, see page 18.

\*1 See "Battery Information" on page 71.

### Soft Keys

Icons and information shown on the display will vary depending on the context. To select an item shown on the display, press the corresponding soft key.

	Opens the Phonebook.		Inserts a dialing pause.
	Stores a new item in the Phonebook.		Clears digits or characters.
	Opens the PBX System Phonebook.		Turns the ringer off.
	Opens the PBX Extension Phonebook.		Opens the function key list. Pressing this key for more than 2 seconds locks all keys.
	Searches for an item in the Phonebook alphabetically.		Returns to the previous display.
	Displayed when in Alphabetic character entry mode. Pressing this key switches to Numeric character entry mode.		Opens the list menu (edit/delete in the Phonebook, etc.).
	Displayed when in Numeric character entry mode. Pressing this key switches to Special character entry mode.		Confirms the entry.
	Displayed when in Special character entry mode. Pressing this key switches to Alphabetic character entry mode.		Displayed when in Key Lock mode. Pressing this key for more than 2 seconds unlocks the keys.
	Displays the Outgoing Call Log.		Advances to the next display.
	Displays the Incoming Call Log.		Used to enter an "x" when storing the Line Access CD.
	Displays the Incoming Call Log Group.		Used to clear the Memo Alarm display setting.
	Used to select an item when in setting mode.		Used to register the handset with the PBX simply.
	Used to select AM or PM when setting the Memo Alarm feature.		Used to seize an outside line in order to make or receive a call.

## Operation Outline

Handset functions are accessed through the display menu and selected with the Navigator Key and soft keys.

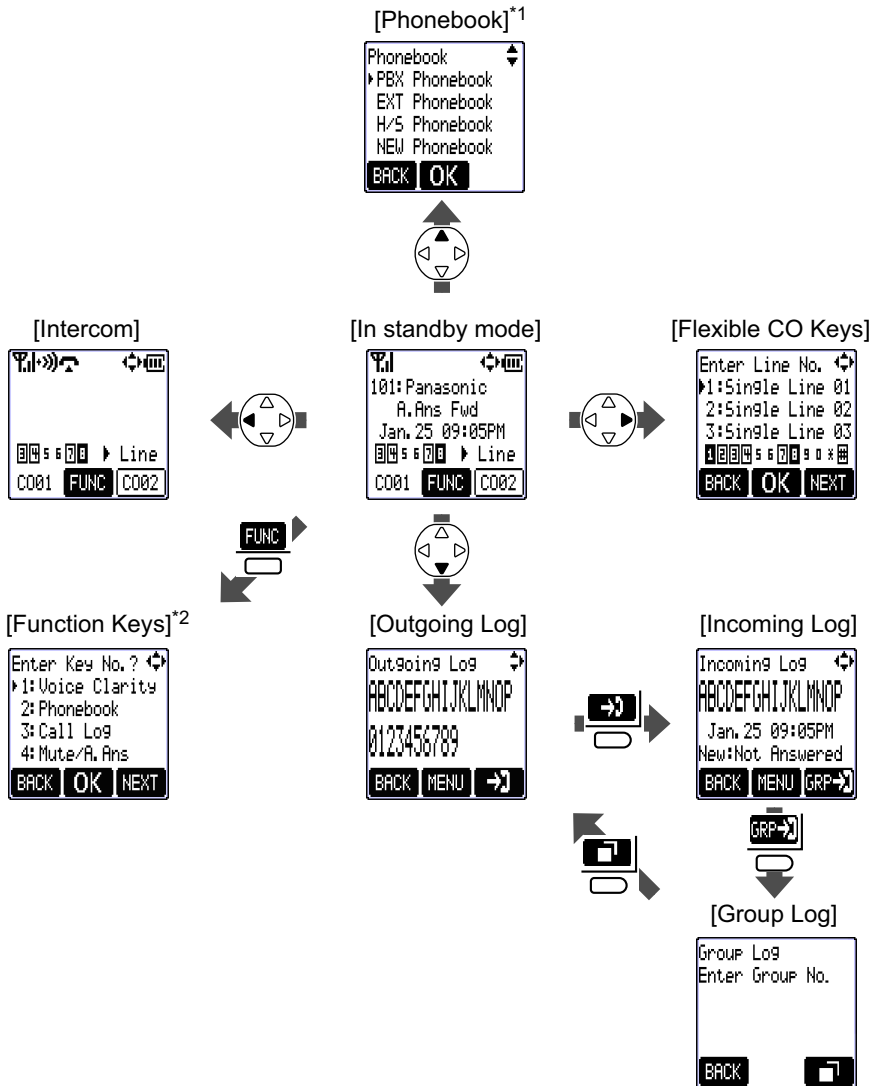

\*1 For more information, see page 41.

\*2 For more information, see page 20.

### Function Keys

Handset functions can be activated through the display key list.  
Press **FUNC** (the **center soft key**) to display the function key list.

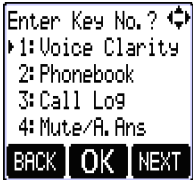

#### 1: Voice Clarity

Reduces background noise to make voice communication clearer.

#### 2: Phonebook

Makes a call using the PBX/EXT/Handset Phonebook.

#### 3: Call Log

Makes a call using the Incoming/Outgoing Call Log.

#### 4: Mute/Auto Answer

Turns the microphone mute feature on or off during a conversation.  
Answers an incoming call automatically in hands-free mode.  
"A. Ans" is displayed in standby mode.

#### 5: Conference

Establishes a multiple-party conversation.

#### 6: Message

Refers to the message left on your handset or calls back the message sender.

#### 7: Fwd/DND

Displays and/or sets Call Forwarding and Do Not Disturb.

#### 8: Pause

Inserts a dialing pause.

#### 9: Memo Alarm

Accesses the "Memo Alarm" settings.

#### 0: Setting

Enters Setting Handset mode or PBX Personal Programming mode.













#### \*: Silent

Turns Silent Mode on or off.

#### #: Volume

Adjusts the ringer volume in standby mode, and adjusts the Receiver/Speaker/Headset volume during a conversation.

- For PBX Personal Programming, refer to the user documentation for your PBX.

Shortcut Combinations			
 <b>1</b>	Voice Clarity	 <b>7<sup>PQRS</sup></b>	Fwd/DND
 <b>2<sup>ABC</sup></b>	Phonebook	 <b>8<sup>TUV</sup></b>	Pause
 <b>3<sup>DEF</sup></b>	Call Log	 <b>9<sup>WXYZ</sup></b>	Memo Alarm
 <b>4<sup>GHI</sup></b>	Mute/Auto Answer	 <b>0<sup>OPER</sup></b>	Setting
 <b>5<sup>JKL</sup></b>	Conference	 <b>*</b>	Silent
 <b>6<sup>MNO</sup></b>	Message	 <b>#</b>	Volume

- For operation, see page 23.

### Flexible CO Keys

A Flexible CO Key can be used either to seize a line in order to make or receive an outside call (F-CO key), or used as a function key. Press the Navigator Key ► to display the Flexible CO Key list. Here you can access the 12 Flexible CO Keys. The key numbers displayed on the 5<sup>th</sup> line of the screen indicate the lines' statuses, similar to the LED indicators on a Proprietary Telephone.

[Example]

























#### Understanding the Flexible CO Keys\*<sup>1</sup>

Key number square's color		Line status
Black	on	You are currently using this line.
	flashing rapidly	You have an incoming call on this line. (An outside call is coming in on a single extension.)
	flashing slowly	You have a call on hold on this line.
White	on	This line is in use by someone else.
	flashing rapidly	You have an incoming call on this line. (An outside call is coming in on multiple extensions simultaneously.)
	flashing slowly	Someone has a call on hold on this line.
No color		This line is idle.

\*1 The meanings of these colors of key numbers vary depending on the status of the outside line.

- To select a key, press its key number, or press the Navigator Key ▲ or ▼ to select the desired key and press **OK** (the **center soft key**).
- To edit the names of Flexible Keys, see page 13.
- For more information, refer to the feature documentation for your PBX.

# Making Calls

Calling	
<p><b>To an extension</b></p>  /  ▶ <b>Extension No.</b> ▶ 	
<p><b>To an outside party</b>  <b>-Using the Line Access Numbers</b></p>  ▶ $\left( \begin{array}{c} \boxed{9} \\ \text{OR} \\ \boxed{8} \end{array} \right) \text{ CO Line Group No.}$ ▶ <b>Outside Phone No.</b> ▶ 	
<p><b>-Using Flexible CO Keys</b></p>  ▶ $\left( \begin{array}{c} \text{idle CO Key No. [0-9, *, \#]} \\ \text{OR} \\ \left( \begin{array}{c} \text{Navigation icons} \\ \text{(idle CO Key)} \end{array} \right) \text{ } \boxed{\text{OK}} \end{array} \right)$ ▶ <b>Outside Phone No.</b> ▶ 	
<p><b>-Using Soft Keys</b></p>  ▶ $\boxed{\text{CO-X}}$ / $\boxed{\text{CO-X}}$ ▶ <b>Outside Phone No.</b> ▶ 	
<p><b>Using Hot Key Dial*<sup>1</sup></b></p> <p>Press the dialing key assigned as a Hot Key for more than 1 second. ▶  (if required) ▶  /  ▶ </p>	
<p><b>Using the Outgoing Call Log*<sup>2</sup></b></p>  ▶  ▶ 	
<p><b>Using the Incoming Call Log</b></p>  ▶ $\boxed{\rightarrow}$ ▶  ▶ 	
<p><b>Using the Incoming Call Log Group</b></p>  ▶ $\boxed{\rightarrow}$ ▶ $\boxed{\text{GRP} \rightarrow}$ ▶ <b>Incoming Call Log Group No.</b> ▶ $\boxed{\text{OK}}$ ▶  ▶  ▶ 	

# Operation

## Calling

Using the Phonebook (PBX System/PBX Extension/Handset)<sup>\*2\*3</sup>

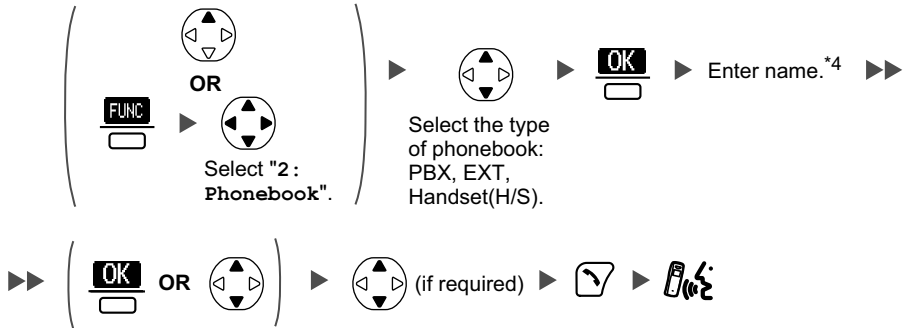

## One-touch Dialling

To store

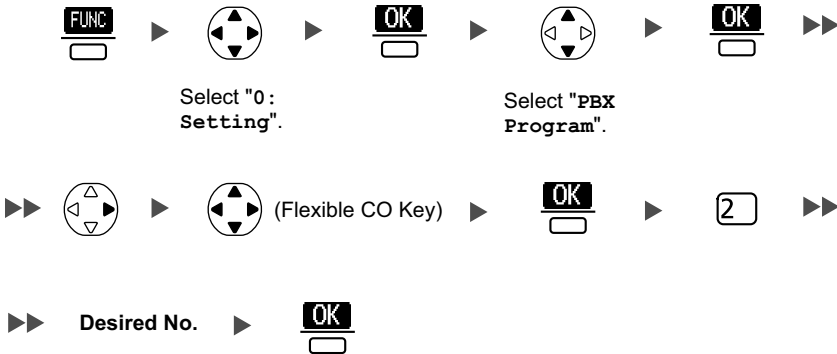

To dial

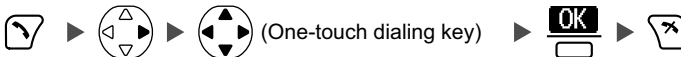

## Hot Line

To store





Hot Line	
<b>To set/cancel</b> ►  7 4 0 ► (  Set /  Cancel ) ►	
<b>To dial</b> ►	

Operator Call	
►  ►	

System Speed Dialling	
<b>To dial</b> ►   ► System Speed Dial No. (3 digits) ►	



Doorphone Call	
►    ► Doorphone No. (2 digits) ►	

Automatic Callback Busy	
<b>To set</b> <i>While hearing a busy tone</i> ►	<b>To cancel</b> ►  4 6 ►
<b>To answer from an idle extension</b> <i>While hearing a callback ring</i> ►	<b>To answer from an idle outside line</b> <i>While hearing a callback ring</i> ► Outside Phone No. ►

- \*1 To assign a phone number to a Hot Key, see page 50.
- \*2 When a call is made using the PBX System Phonebook, the called party's name is not stored in the Outgoing Call Log. To log the name as well as the number, copy the item into the Handset Phonebook before dialing it. (See page 48.)
- \*3 To store an item in the Phonebook, see page 42.  
To search for an item stored in the Phonebook, see page 27.
- \*4 This step can be omitted.
- To enter characters, see page 51.
- You can confirm that the number was dialed correctly before calling (**Predialing**) by entering the number, then pressing .
- To clear an entire number while predialing, press for more than 1 second.

## Operation

---

- If an outside call is received from a phone number stored in the Handset Phonebook, the number and name of the caller will be displayed in the call log.
- To cancel dialing, press .
- If "  " flashes, move closer to the CS and dial again.
- For more information, refer to the user documentation for your PBX.

## Searching for an item stored in the Phonebook

You can search for an item in the Phonebook by following the steps below.

### PBX/Extension/Handset Phonebook

#### Scrolling through all items

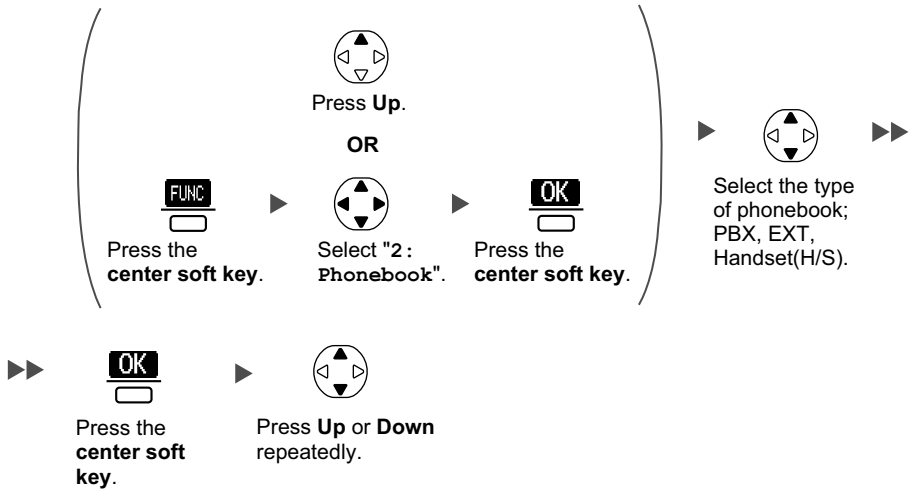

## Operation

### Searching by name or first character(s) of name

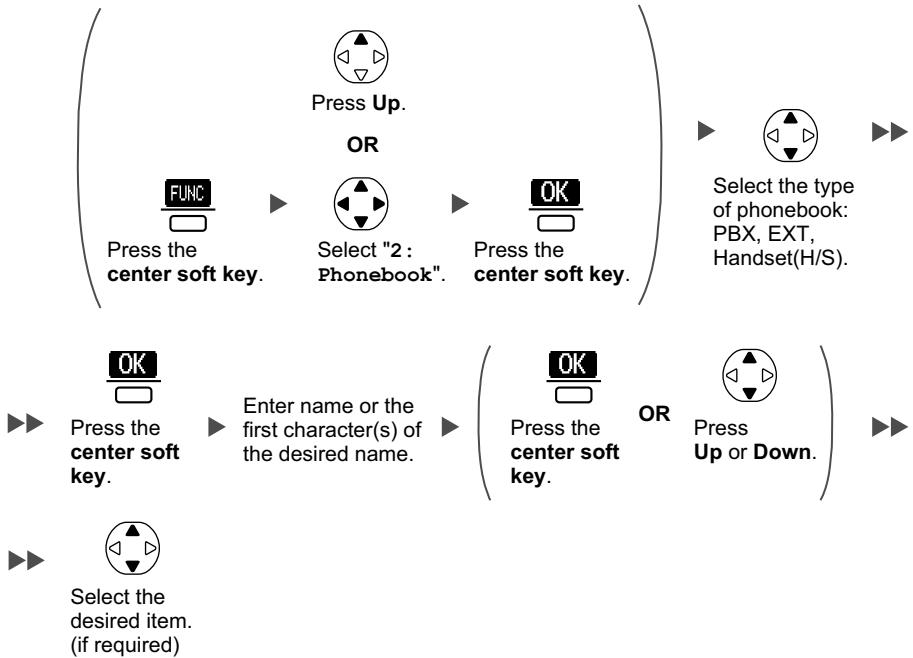



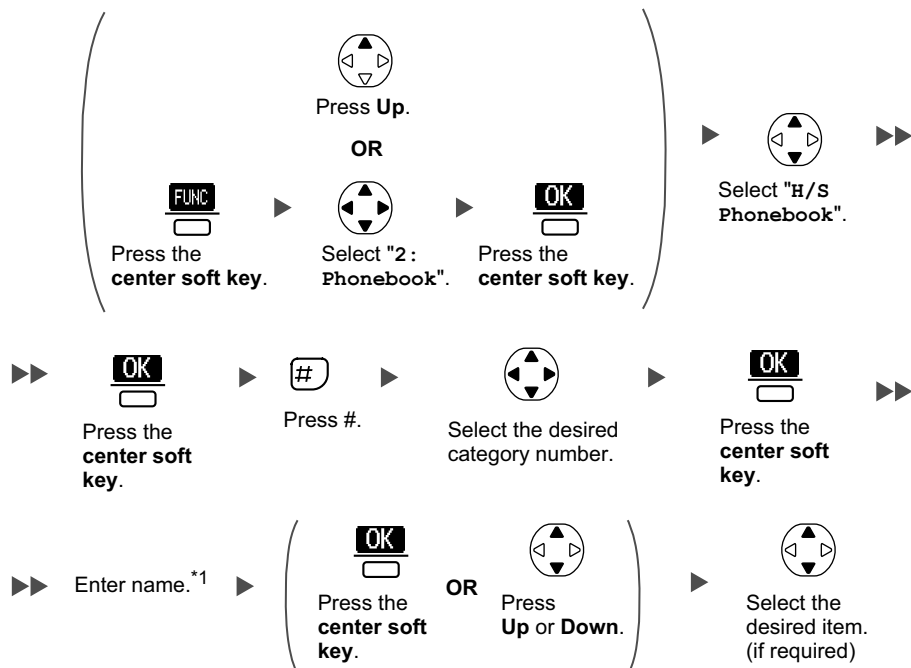

Searching by category - Handset Phonebook only



\*1 This step can be omitted.

- To enter characters, see page 51.
- While an item is displayed you can:
  - Return to the "<Enter Name>" display by pressing  (the **right soft key**), then search for another item.
  - Search for another item by pressing the dial key that corresponds to the letter you are searching for. If there is no entry that corresponds to the letter you selected, the next entry will be displayed.

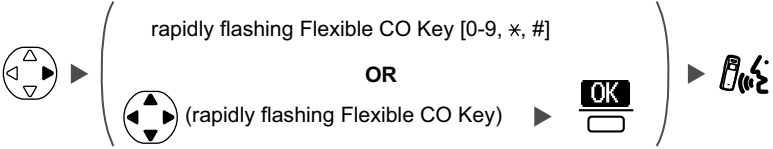
# Receiving Calls

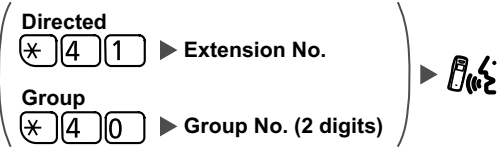
Receiving	
<b>An Intercom Call</b>	
<b>An Outside Call/A Group Call</b>	
<b>An Outside Call on a specific line</b>	
Call Pickup	
	

- You can also answer a call using the following features:
  - Any Key Answer (See "Answer Option" on page 61.)
  - Quick Answer (See "Answer Option" on page 61.)
  - Auto Answer (See "Answer Option" on page 61.)

### Note

- Please consider the following when "Quick Answer" is set to "On".
  - If a brief power failure occurs when the handset is receiving a call on the charger,
    - if "Talk On Charger" is set to "Off" (default), the call may be disconnected after being answered.
    - if "Talk On Charger" is set to "On", the call may be answered automatically. In this case, please note that privacy rights may be violated or sensitive information may be transmitted to unauthorized parties.
- You can select the ring and vibrate pattern for each type of incoming call. (See "Incoming Option" on page 60.)
- For more information, refer to the user documentation for your PBX.

---

## Caller ID

If an outside call that contains Caller ID information (a caller's name and telephone number) is received, this information will be logged in the incoming call log and displayed on the handset in one of the two following ways:

- If the caller's information is stored in the PBX or in the handset, that information can be displayed.



- If information is stored in both the PBX and in the handset for the same caller, you can choose which information will be displayed on the handset. Caller information stored in the PBX is displayed by default. (See "Display Option" on page 62.) If you set the handset to display the caller information stored in the handset, caller information stored in the PBX will only be displayed if the caller information is not stored in the handset.
- The caller information can be displayed even if a line access number, CO line number, or "P" (Pause) is stored in the Phonebook. (See "Other Option" on page 64.)

## During a Conversation

### Transferring a Call

To an extension



To an outside party

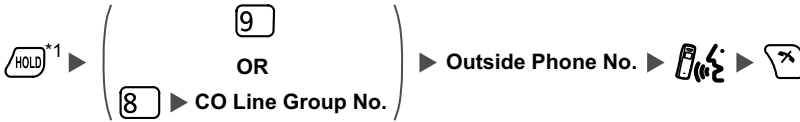

### Holding

To hold (Regular Hold)



To hold (Exclusive Call Hold)



To retrieve a call

-An Intercom Call



-An Outside Call

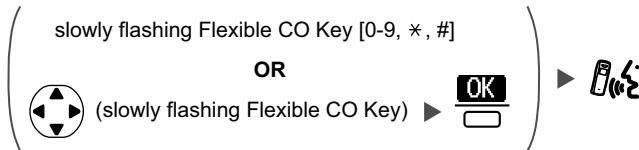



### Three-party Conference

#### To add another party during a conversation



Select "5 :  
Conference".



Select "5 :  
Conference".

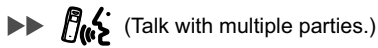

#### To leave a conference



Press the center soft key.      Select "5 :  
Conference".      Press the center soft key.

\*1 The HOLD Key must be set to "XFER". (See "Key Option" on page 61.)

- To return to the call before the transfer destination answers, press .
- The method used to hold a call depends on the Call Hold mode (Regular Hold/Exclusive Call Hold). Ask your manager what the current mode is.
- To hold several outside calls, you need to assign Flexible CO Keys (Single Line/Loop Line/Trunk Group) as necessary beforehand.
- For more information, refer to the user documentation for your PBX.

## Useful Features

### Call Forwarding

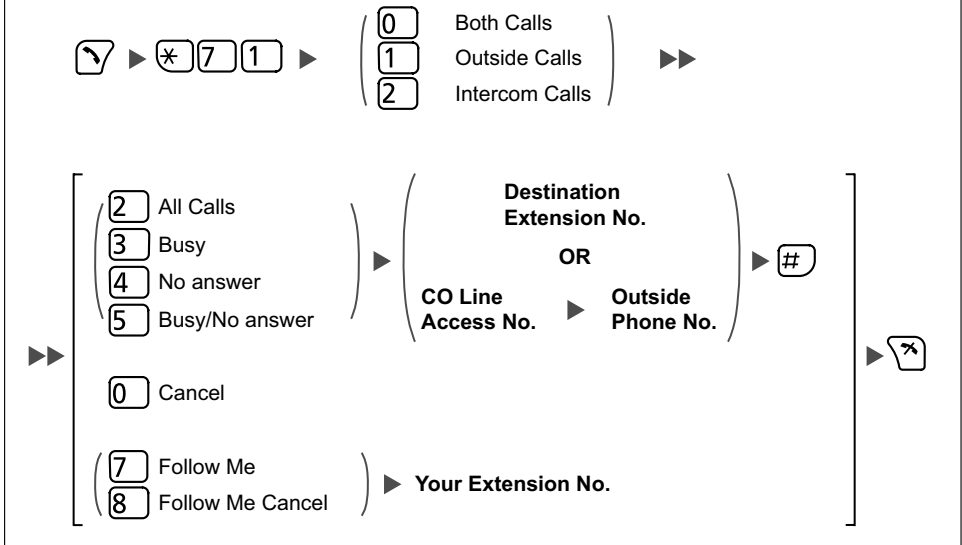

### Do Not Disturb

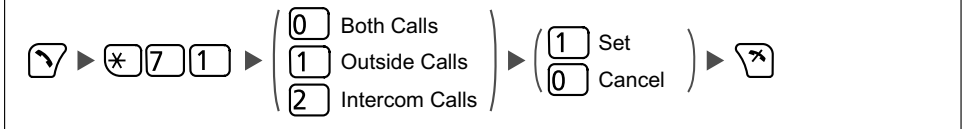

### Sending a Call Waiting Tone\*1

While hearing a busy tone

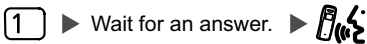

### Call Waiting

To set/cancel for intercom calls



To set/cancel for outside calls



**Call Waiting**

To talk to the new party (While hearing the Call Waiting tone)

-To terminate the current status



-To hold and then talk to the new party

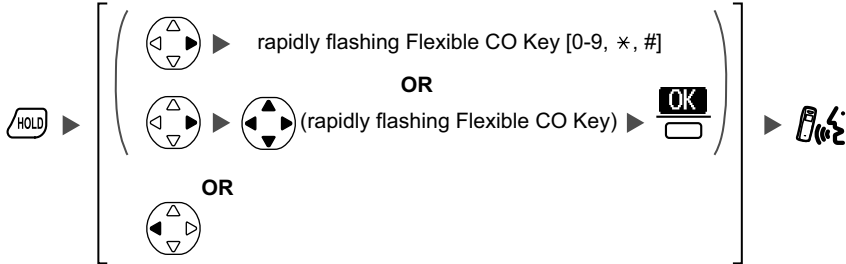

Disregard this step if both parties are extensions.

**Paging**

To page

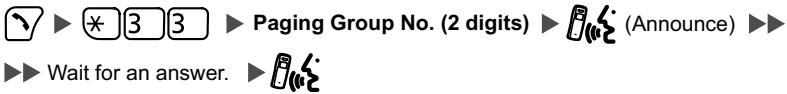

To answer

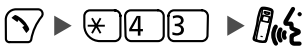

## Operation

### Absent Message

To set

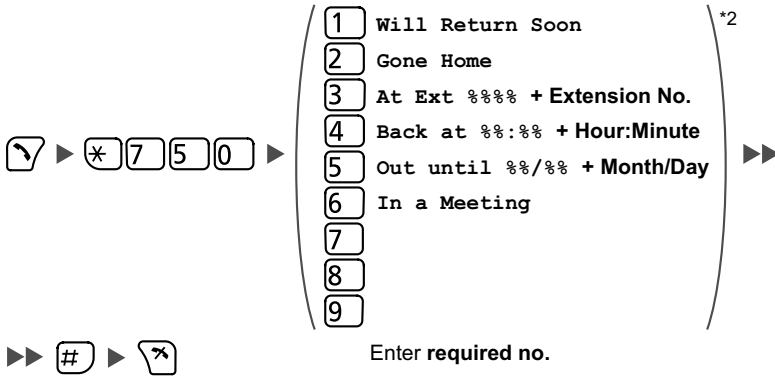

To cancel



### Log-in/Log-out

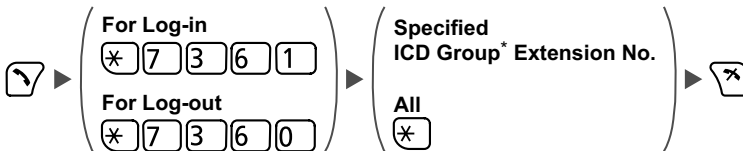

\* ICD Group: Incoming Call Distribution Group

### Extension Feature Clear

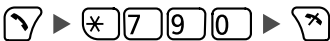

### Extension Dial Lock<sup>3</sup>

To lock



To unlock



\* PIN: Personal Identification Number

**Message Waiting**

**Caller**

**-To leave a message waiting indication**

*When the called extension is busy or does not answer*

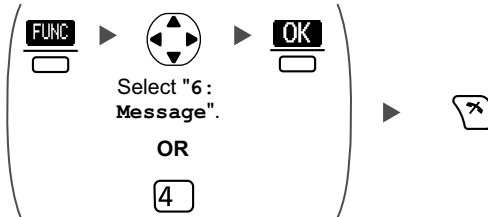

**-To cancel a message waiting indication**



**Called extension**

**-To call back**

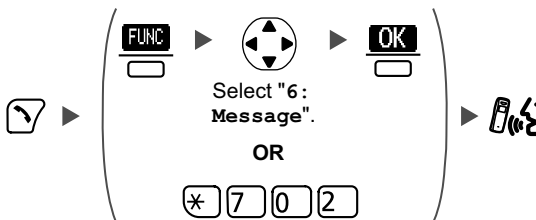

**-To clear message waiting indications left on your extension<sup>\*4</sup>**



\*1 You cannot send a call waiting tone when:

- the called party has not set the Call Waiting feature.
- the called party has set the Data Line Security feature.

\*2 Enter the desired value in the "%" positions. You must enter the correct number of characters as represented by the "%" using 0 to 9 or \*.

To change the default messages and create your personal messages (Message no. 9), refer to the documentation for your PBX.

\*3 If you do not set an extension PIN, you cannot lock and unlock your extension.

For more information, refer to the user documentation for your PBX.

\*4 You can register a Flexible CO Key to the clear message waiting indications feature (for one-touch operation).

## To register

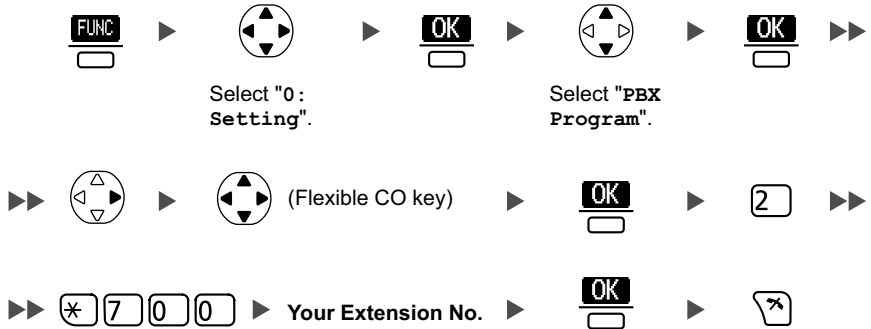



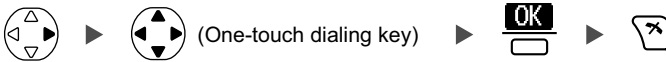











## To clear message waiting indications (one-touch operation)



- For more information, refer to the user documentation for your PBX.

## Making Use of the Voice Mail Service

Listening to a Message	
<p><b>From your own extension</b></p> <p> ► <b>VPS* Extension No.</b> ►►</p> <p>►► <b>Mailbox Password*<sup>1</sup> +</b> </p> <ul style="list-style-type: none"> <li>If you have no password, you can skip the last step.</li> </ul> <p>* VPS: Voice Processing System</p>	<p>►</p> <div style="display: flex; align-items: center; justify-content: center;"> <div style="font-size: 4em; margin-right: 10px;">(</div> <div style="text-align: left;"> <p> Listen to Message</p> <p> Deliver Message</p> <p> Mailbox Management</p> <p> Automated Attendant</p> <p> Message Notification</p> <p> Other Features</p> <p> End Call</p> </div> <div style="font-size: 4em; margin-left: 10px;">)</div> </div>
<p><b>From someone else's extension</b></p> <p> ► <b>VPS Extension No.</b> ►►</p> <p>►►   ►  ►►</p> <p>►► <b>Mailbox No.</b> ►►</p> <p>►► <b>Mailbox Password*<sup>1</sup> +</b> </p> <ul style="list-style-type: none"> <li>If you have no password, you can skip the last step.</li> </ul>	

## Operation

### Leaving a Message

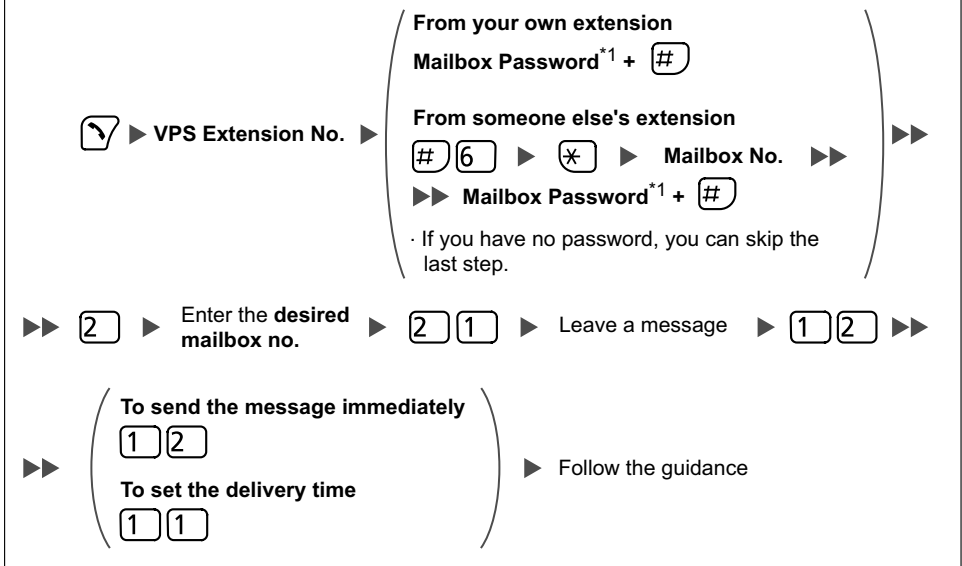

### During Playback

0 Repeat Voice Guidance

\* Exit Menu

\*1 For more information on the Mailbox Password, refer to the user documentation for the VPS.

- Some feature access numbers may vary depending on the market. Please consult your local dealer for details.



### Handset Phonebook

You can store up to 100 items with names, phone numbers, and category numbers in the handset for easy access. You can set unique ringer/vibrate patterns for each category to identify incoming calls. All Phonebook items are stored in alphabetical order. For security purposes, you can lock the Phonebook. To make a call using the Phonebook, see page 23.

#### **Note**

We recommend that you keep a copy of your Handset Phonebook in case data becomes unrecoverable due to product malfunction.

---

### Private Ring

You can organise entries in the Phonebook into one of 9 Private Ring Categories. It is possible to set a different ringer/vibrate pattern\*<sup>1</sup> for each category. When the displayed Caller ID\*<sup>2</sup> matches a phone number or name stored in the Phonebook, the handset rings according to the Private Ring Category settings.

\*1 For ringer/vibrate patterns, see "Incoming Option" on page 60.

\*2 For Caller ID information, see "Caller ID" on page 31.

## Storing an Item in the Handset Phonebook

### Storing a New Item

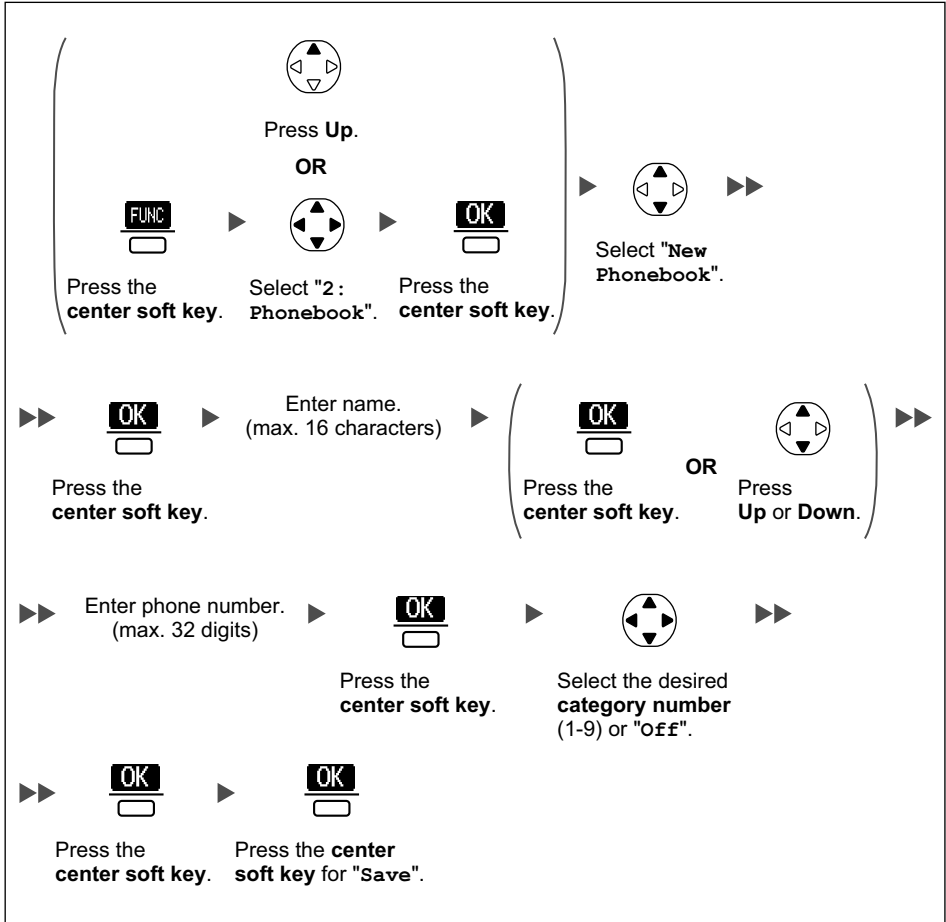

- To enter characters, see page 51.
- The valid digits are "0" through "9", "\*", "#", "P" (Pause).
- When storing an outside phone number, you should first store a line access number.

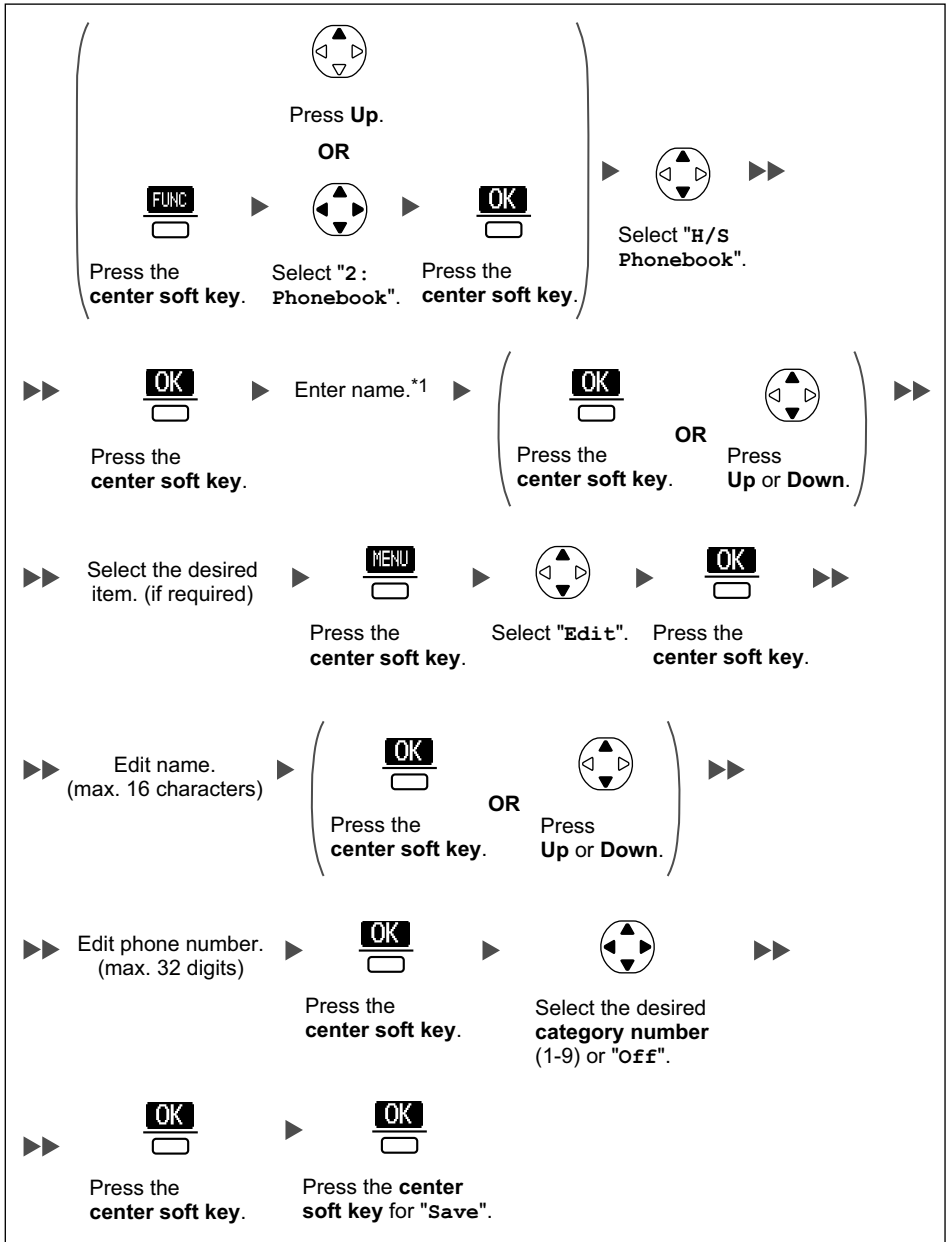

Editing a Stored Item



\*1 This step can be omitted.

## ***Using the Handset Phonebook***

---

- To enter characters, see page 51.
- To search for an item in the Phonebook, see page 27.
- The valid digits are "0" through "9", "\*", "#", "P" (Pause).
- To change a character or digit, press the Navigator Key ◀ or ▶ to highlight it, press  to delete it, then enter the new character or digit.
- To clear an entire line, press  for more than 1 second.
- To move the cursor to the left or right, press the Navigator Key ◀ or ▶, respectively.

## Storing an Item Using Predialing

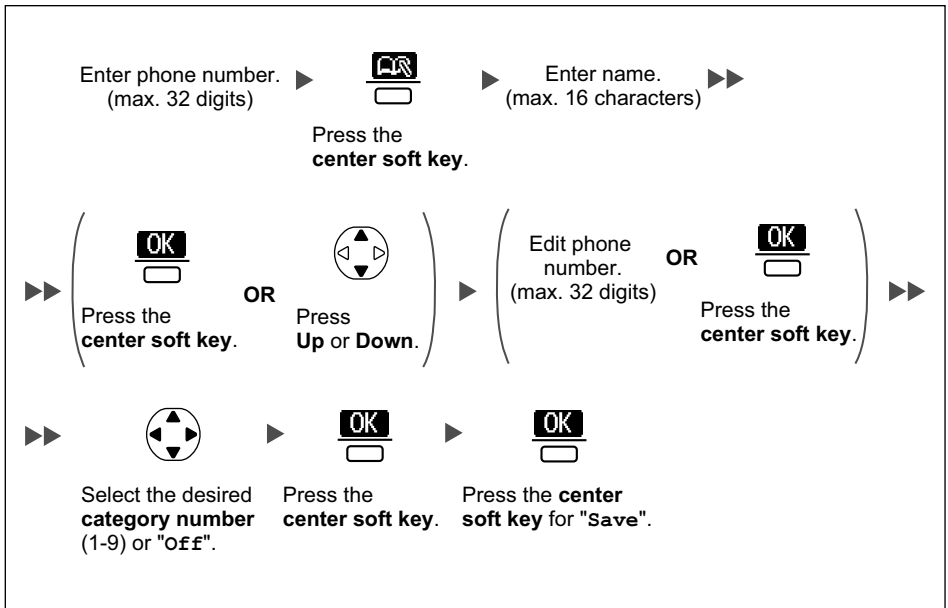

### Storing an Item Using the Outgoing Call Log

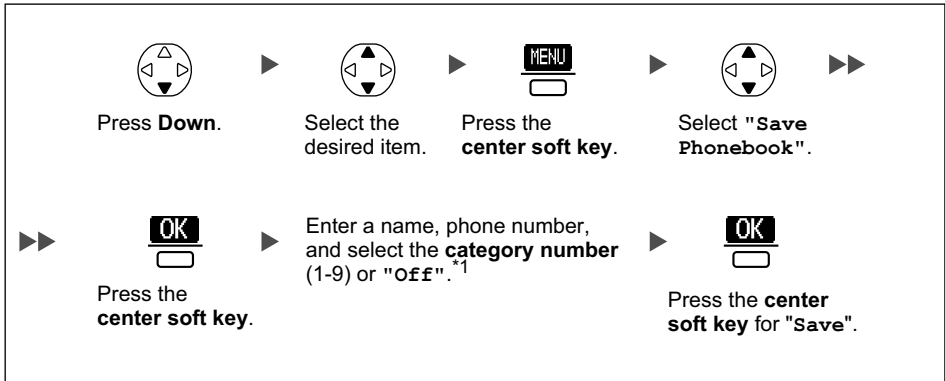

- \*1 Press **OK** (the **center soft key**) to confirm each entry. (name: max. 16 characters/phone number: max. 32 digits)
- When storing an outside phone number, the line access number will be stored automatically. The line access number must be identical to the handset's "**Line Access CD**" setting. (See "Other Option" on page 64.)

### Storing an Item Using the Incoming Call Log

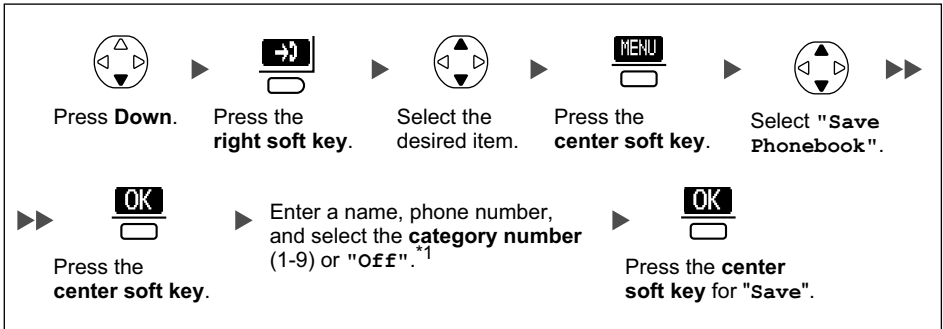

\*1 Press **OK** (the **center soft key**) to confirm each entry. (name: max. 16 characters/phone number: max. 32 digits)

- When storing an outside phone number, the line access number will be stored automatically. The line access number must be identical to the handset's "Line Access CD" setting. (See "Other Option" on page 64.)

## Storing an Item Using the PBX System/Extension Phonebook

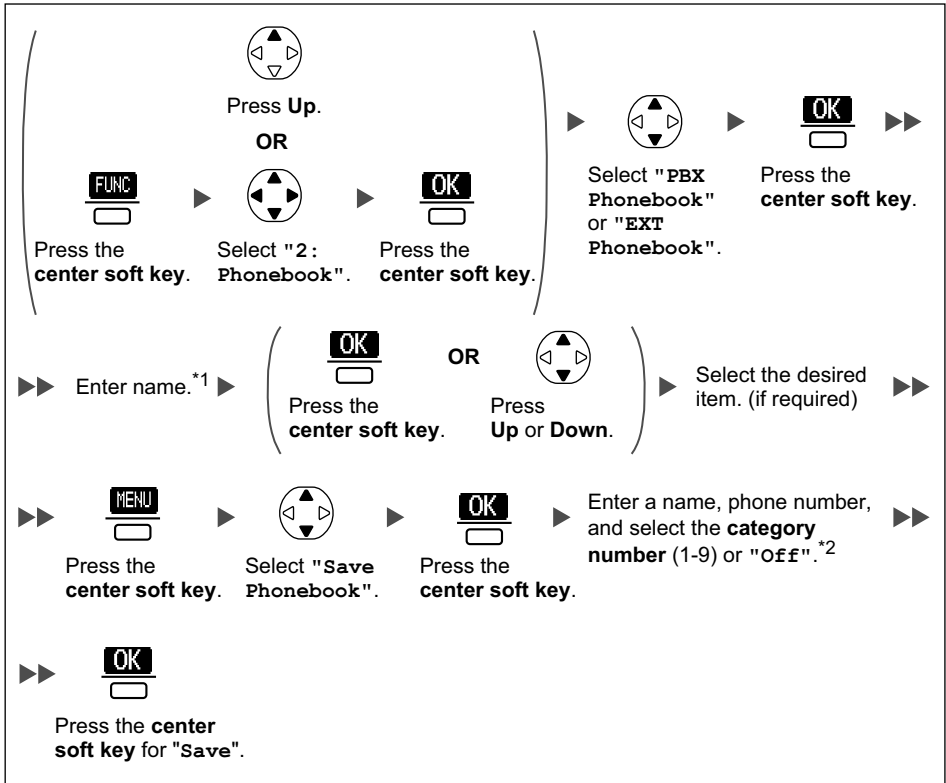

\*1 This step can be omitted.

\*2 Press **OK** (the **center soft key**) to confirm each entry. (name: max. 16 characters/phone number: max. 32 digits)

- To search for an item in the Phonebook, see page 27.



## Editing Category Names

You can edit the names of the categories in the Handset Phonebook.

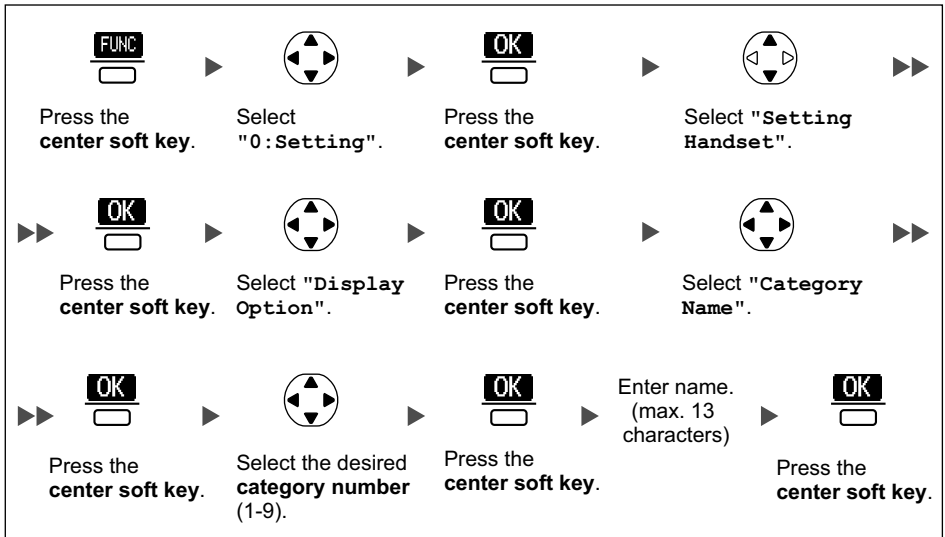

### Assigning Hot Keys

You can assign a phone number stored in the Handset Phonebook to a key to be used as a Hot Key.

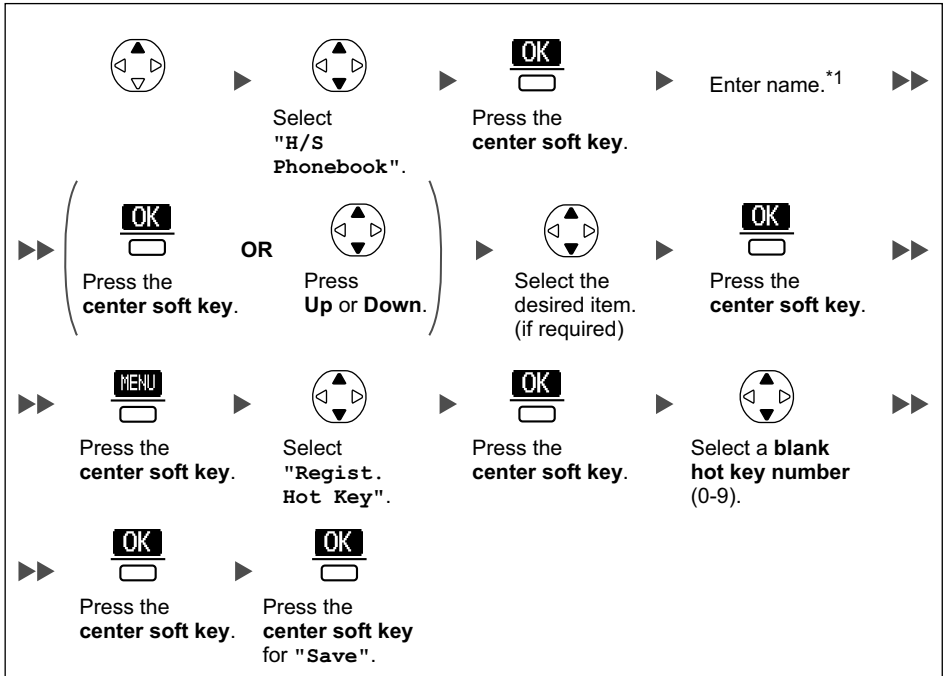

\*1 This step can be omitted.

- To search for an item in the Phonebook, see page 27.
- A "✓" will be displayed next to hot key numbers that have a Phonebook item registered to them.

## Entering Characters

You can enter characters and digits using the dialing keys.

You can select one of 3 character modes by pressing the **Right Soft Key** while entering a name. The function icon above the soft key displays the current character mode.

For available characters, see "Character Mode Table" (page 52).

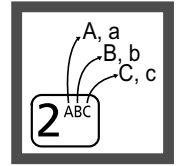

To change the character mode while editing a name in the Phonebook, press the **right soft key**.

Alphabetic



Numeric



Extended



**Example:** To enter "Anne" in Alphabet Mode.



- To switch between uppercase and lowercase, press .
- To enter a character located on the same dialing key as the previous character, move the cursor by pressing the Navigator Key , then enter the desired character.
- If you enter a different character by mistake, press the Navigator Key or to highlight the character, press to delete it, then enter the correct character.
- To clear an entire line, press for more than 1 second.
- To move the cursor, press the Navigator Key , , or .

## Character Mode Table

Keys	ABC (Alphabetic)	0-9 (Numeric)	+ÄÅ (Extended)
<b>1</b>	Space # & ' ( ) * , - . / 1	<b>1</b>	Space # & ' ( ) * , - . / 1
<b>2<sup>ABC</sup></b>	A B C 2	<b>2</b>	A Ä Á Â Ã Ä Å Æ B C Ç 2
	a b c 2		a ä á â ã ä å æ b c ç 2
<b>3<sup>DEF</sup></b>	D E F 3	<b>3</b>	D E È É Ê Ë Ì 3
	d e f 3		d e è é ê ë ì 3
<b>4<sup>GHI</sup></b>	G H I 4	<b>4</b>	G Ğ H I Í Î Ï 4
	g h i 4		g ğ h i í î ï 4
<b>5<sup>JKL</sup></b>	J K L 5	<b>5</b>	J K L 5
	j k l 5		j k l 5
<b>6<sup>MNO</sup></b>	M N O 6	<b>6</b>	M N Ñ O Ó Ô Õ Ö Ø 6
	m n o 6		m n ñ o ó ô õ ö ø 6
<b>7<sup>PQRS</sup></b>	P Q R S 7	<b>7</b>	P Q R S Ş ß 7
	p q r s 7		p q r s ş ß 7
<b>8<sup>TUV</sup></b>	T U V 8	<b>8</b>	T U Û Ú Û Ü Û V 8
	t u v 8		t u ù ú û ü ù v 8
<b>9<sup>WXYZ</sup></b>	W X Y Z 9	<b>9</b>	W Ŵ X Y Ŷ Z 9
	w x y z 9		w ŵ x y ŷ z 9
<b>0<sup>OPER</sup></b>	Space 0	<b>0</b>	Space 0

- Press **\*** before or after entering a character to change between uppercase and lowercase.
- Pressing a key repeatedly will cycle through the characters associated with that key. For example, to enter the letter "C", press **2<sup>ABC</sup>** three times.

## Locking the Handset Phonebook

You can lock/unlock the Phonebook while the handset is in standby mode.  
If no password has been set, you cannot lock the Phonebook.

### Locking/Unlocking the Handset Phonebook

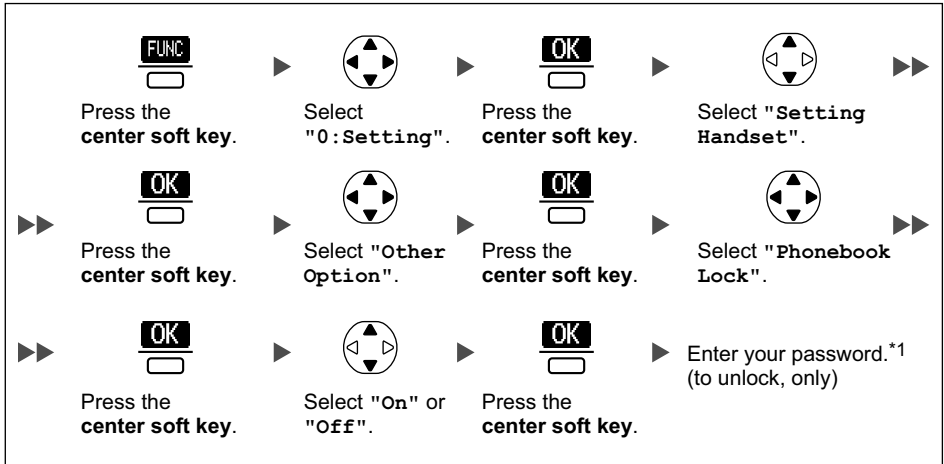

### Unlocking the Handset Phonebook Temporarily

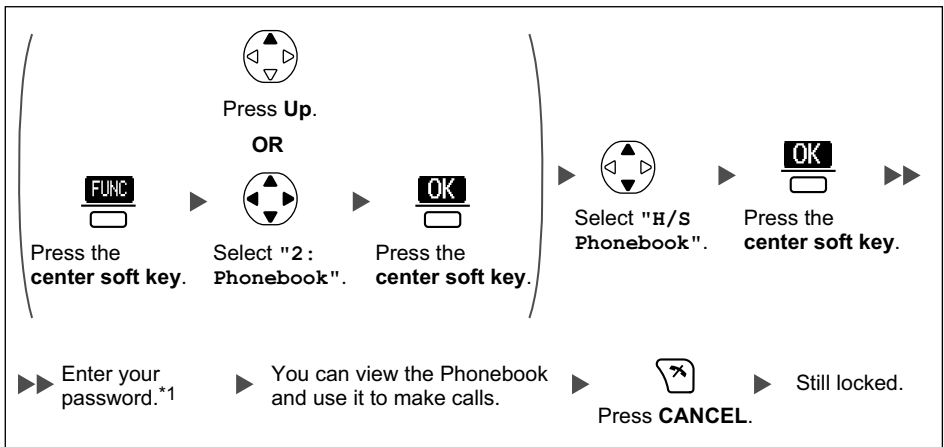

\*1 To change the password, see page 64.

# Deleting Stored Items in Handset Phonebook/Hot Key Dial/Outgoing Call Log/Incoming Call Log

## Handset Phonebook

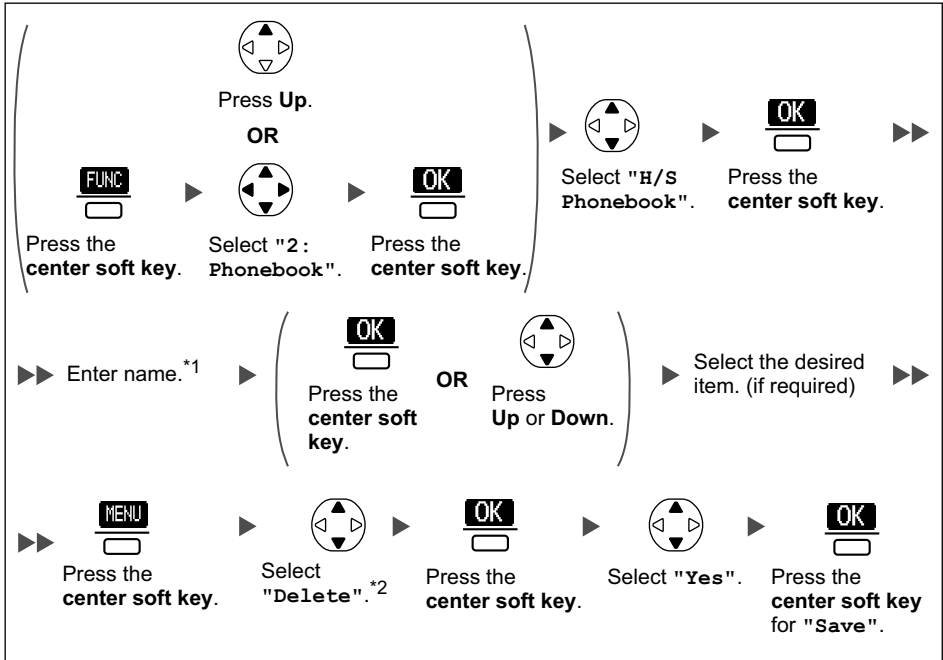

\*1 This step can be omitted.

\*2 Select "Delete All" if you want to delete all items.

- To search for an item in the Phonebook, see page 27.

## Hot Key Dial

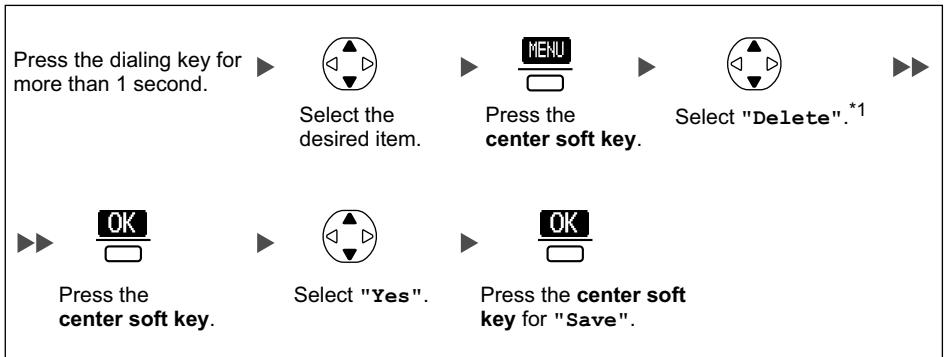

\*1 Select "Delete All" if you want to delete all items.

- If you delete a Phonebook item that you also assigned to a Hot Key, the Hot Key Dial is also deleted. (See page 50.)

## Deleting Stored Items

---

### Outgoing Call Log

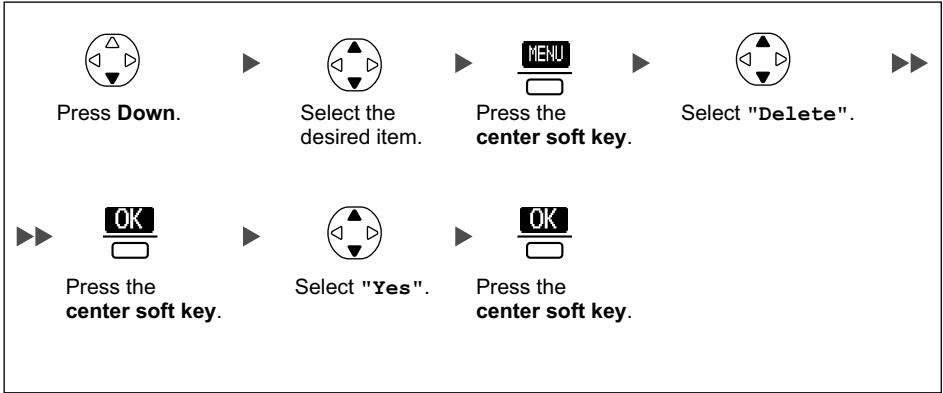

### Incoming Call Log

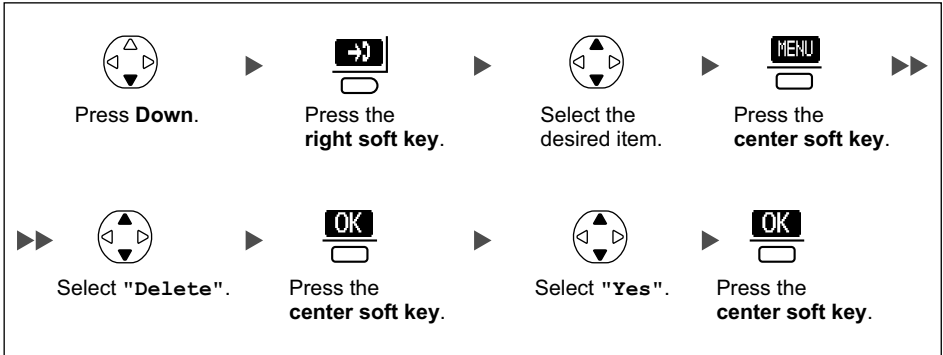



### Changing the Initial Settings

You can customise the handset by editing the settings found under "Setting Handset" in the menu list, as follows:

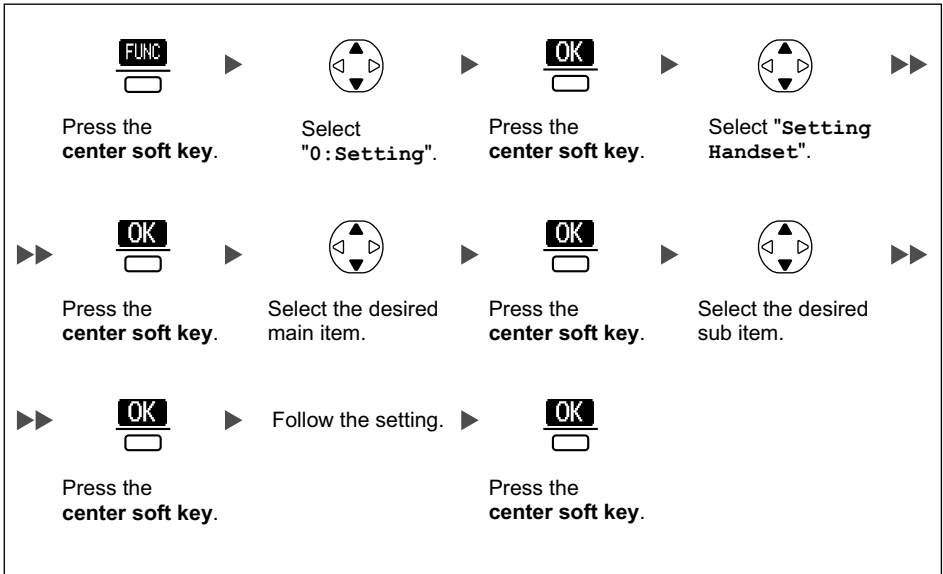

- To return to the previous menu item, press **BACK** (the **left soft key**).
- To cancel, press  at any time.
- The handset will beep to indicate that the new settings have been saved.

## Handset Setting Menu Layout

	[Main Item]	[Sub Item]
Setting Handset	Incoming Option	Ringer Volume
		Ringer Type
		Vibrate (KX-WT126 only)
		Ring On Charger
		Memo Alarm
		Headset Ringer
		Talk Option
		Receiver Volume
		Headset Volume
		Headset Mic Vol
		Talk On Charger
	Answer Option	Any Key Answer
		Quick Answer
		Auto Answer
		Auto Ans Delay
	Key Option	F-CO Key Name
		HOLD/XFER Key
	Display Option	Language
		Backlight
		LCD Contrast
		Standby Display
		Category Name
		Date&Time Form
		Caller ID Disp
	CO Status Disp	
Tone Option	Key Tone	
	Range Alarm	
System Option	Register H/S	
	Cancel Base	
	Select Base	
	System Lock	

|  
└ Other Option

└ Change PIN  
└ Change Password  
└ Line Access CD  
└ Reset Handset  
└ Phonebook Lock

## Configuring Handset Settings

### Incoming Option

Sub Item	Description	Setting	Default
<b>Ringer Volume</b>	Adjusts the ringer volume.	<ul style="list-style-type: none"> <li>Step Up</li> <li>Step Down</li> <li>Level 1-6</li> <li>Off</li> </ul>	Level 3
<b>Ringer Type</b> – Intercom Ring	<b>Ringer Pattern</b> Selects the ringer pattern for each type of call.	<ul style="list-style-type: none"> <li>Bell 1-5</li> <li>Melody 1-3</li> </ul>	Bell 1 Bell 5 (Doorphone only)
– CO Ring – Group Ring – Doorphone – Private Ring (Category 1-9)	<b>Vib. Pattern</b> (KX-WT126 only) Selects the vibrate pattern for each type of call.	<ul style="list-style-type: none"> <li>Single</li> <li>Double</li> <li>Triple</li> <li>Short Double</li> <li>Short Triple</li> <li>Short Term</li> <li>Continuous</li> </ul>	Single
<b>Vibrate</b> (KX-WT126 only)	Selects whether the handset vibrates while receiving a call.	<ul style="list-style-type: none"> <li>Vib.&amp; Ring</li> <li>Vib.→ Ring</li> <li>Off</li> </ul>	Off
<b>Ring On Charger</b>	Selects the ringing mode (On or Off) while a handset is set on the charger.*1	<ul style="list-style-type: none"> <li>On</li> <li>Off</li> </ul>	On
<b>Memo Alarm</b>	<b>Ringer Pattern</b> Selects the ringer pattern for each Memo Alarm.	<ul style="list-style-type: none"> <li>Bell 1-5</li> <li>Melody 1-3</li> </ul>	Bell 1
	<b>Vib. Pattern</b> (KX-WT126 only) Selects the vibrate pattern for each Memo Alarm.	<ul style="list-style-type: none"> <li>Single</li> <li>Double</li> <li>Triple</li> <li>Short Double</li> <li>Short Triple</li> <li>Short Term</li> <li>Continuous</li> </ul>	Single
<b>Headset Ringer</b>	Selects whether a tone is heard from the attached headset while receiving a call.	<ul style="list-style-type: none"> <li>On</li> <li>Off</li> </ul>	Off

\*1 When "Ring On Charger" is set to "On" but "Ringer Volume" is set to "Off", the handset rings at level 1.

### Talk Option

Sub Item	Description	Setting	Default
Speaker Volume	Adjusts the rear speaker volume.	Level 1-6	Level 3
Receiver Volume	Adjusts the receiver volume.	Level 1-4	Level 2
Headset Volume	Adjusts the headset speaker volume.	Level 1-4	Level 2
Headset Mic Vol	Adjusts the headset microphone volume.	Level 1-4	Level 1
Talk On Charger	Selects whether or not to continue the conversation when the handset is put on the charger during a conversation.	<ul style="list-style-type: none"> <li>• On</li> <li>• Off</li> </ul>	Off

### Answer Option

Sub Item	Description	Setting	Default
Any Key Answer	Answers a call by pressing any dialing key.	<ul style="list-style-type: none"> <li>• On</li> <li>• Off</li> </ul>	Off
Quick Answer	Answers a call while the phone is charging by just lifting up a handset from the charger.	<ul style="list-style-type: none"> <li>• On</li> <li>• Off</li> </ul>	Off
Auto Answer	Selects the types of calls that can be answered by Auto Answer.	<ul style="list-style-type: none"> <li>• Int Only</li> <li>• Int &amp; CO</li> </ul>	Int Only
Auto Ans Delay	Selects the number of seconds before a call is automatically answered when Auto Answer is turned on.	0 s-20 s	6 s

### Key Option

Sub Item	Description	Setting	Default
F-CO Key Name	Edits the names of the flexible CO keys.	Max. 12 characters x 12 flexible CO keys x 4 bases	Not stored
	Edits the name of the soft key for a flexible CO key.	Max. 5 characters x 2 flexible CO keys x 4 bases	Not stored
HOLD/XFER Key	Selects the function of the HOLD/TRANSFER Key.	<ul style="list-style-type: none"> <li>• HOLD</li> <li>• XFER</li> </ul>	HOLD

## Configuring Handset Settings

### Display Option

Sub Item	Description	Setting	Default
<b>Language</b>	Selects the display language.	<ul style="list-style-type: none"> <li>• Auto</li> <li>• English</li> <li>• Español</li> <li>• FRANÇAIS</li> </ul>	Auto
<b>Backlight</b>	Turns on the backlight of the LCD and keypad.	<ul style="list-style-type: none"> <li>• On</li> <li>• On &amp; Receiving</li> <li>• Off</li> </ul>	On
<b>LCD Contrast</b>	Adjusts the LCD contrast.	Level 1-5	Level 3
<b>Standby Display</b>	Selects what is shown on the display while in standby mode.*1	<ul style="list-style-type: none"> <li>• H/S No.</li> <li>• Base &amp; H/S No.</li> <li>• Edit</li> </ul>	H/S No.
	Edits the name displayed on the LCD while in standby mode.	Max. 16 characters/4 digits	Not stored
<b>Category Name</b>	Edits the names of the categories.	Max. 13 characters x Category (1-9)	Not stored
<b>Date&amp;Time Form</b>	Selects the format for the date shown on the display in standby mode.	<ul style="list-style-type: none"> <li>• DD-MM 12H</li> <li>• DD-MM 24H</li> <li>• MM-DD 12H</li> <li>• MM-DD 24H</li> <li>• DD-MM-YY</li> <li>• MM-DD-YY</li> </ul>	MM-DD 12H
<b>Caller ID Disp</b>	Selects which caller information is displayed when a call is received. Either the information stored in the Handset Phonebook or the PBX can be displayed.	<ul style="list-style-type: none"> <li>• H/S Phonebook</li> <li>• PBX Setting</li> </ul>	PBX Setting
<b>CO Status Disp</b>	Selects whether the CO status is shown on the display in standby mode.	<ul style="list-style-type: none"> <li>• On</li> <li>• Off</li> </ul>	On

\*1 If an extension name is stored in the PBX, the extension name is displayed when "H/S No." or "Base & H/S No." is selected. Depending on the number of characters stored for the extension name, the end of the extension name may not be displayed.

### Tone Option

Sub Item	Description	Setting	Default
<b>Key Tone</b>	Turns the key tone on or off.	<ul style="list-style-type: none"> <li>• On</li> <li>• Off</li> </ul>	On
<b>Range Alarm</b>	Selects whether the range alarm tone rings or not.	<ul style="list-style-type: none"> <li>• On</li> <li>• Off</li> </ul>	On

### System Option

Sub Item	Description	Setting	Default
<b>Register H/S</b>	Registers a handset to a base.	Base 1-4	Not stored
<b>Cancel Base</b> *1	Cancels the registration of a handset.	Base 1-4*2	–
<b>Select Base</b> *1	Selects a base.	<ul style="list-style-type: none"> <li>• Auto</li> <li>• Base 1-4</li> </ul>	–
<b>System Lock</b>	Selects whether to lock the System Option setting or not.	<ul style="list-style-type: none"> <li>• On*3</li> <li>• Off</li> </ul>	Off
<b>Change PIN</b>	Before registering your handset with a PBX, enter the PBX's PIN here. Once you have registered the handset with a PBX, this PIN can be changed so that the handset can be registered to an additional PBX.	Enter the PIN number. (max. 8 digits)	1234

\*1 Only registered bases are shown.

\*2 You can select multiple bases simultaneously.

\*3 Password is required. (4 digits)

## Configuring Handset Settings

### Other Option

Sub Item	Description	Setting	Default
<b>Change Password</b> *1	Changes the handset password (4 digits) used for unlocking the Handset Phonebook and using the "Reset Handset" option.	Enter Old Password.*2 ↓ Enter New Password. ↓ Verify New Password.	Not registered
<b>Line Access CD</b>	Enters the line access code that matches the setting of your PBX. Three access line codes can be stored.	Select a number, then enter the code. (max. 6 digits)	No.1: 9 No.2: 8XX*3 No.3: Not Stored
<b>Reset Handset</b>	Returns the handset settings to its default settings.	Enter Password. (4 digits) ↓ Select the desired item(s). ↓ Press "OK".	Not selected
<b>Phonebook Lock</b>	Locks/unlocks the Phonebook while the handset is in standby mode.	<ul style="list-style-type: none"> <li>• On</li> <li>• Off</li> </ul>	Off

\*1 Make a note of the password so that you will not forget it.

\*2 If a password has not already been set, you can skip the first step.

\*3 XX is identical to the CO line group number, and 8XX represents any 3-digit code starting with "8".



### Memo Alarm Setting

An alarm will sound at the set time. A memo can also be displayed. Memo Alarm is available only when the handset is within range of a CS.

#### To set

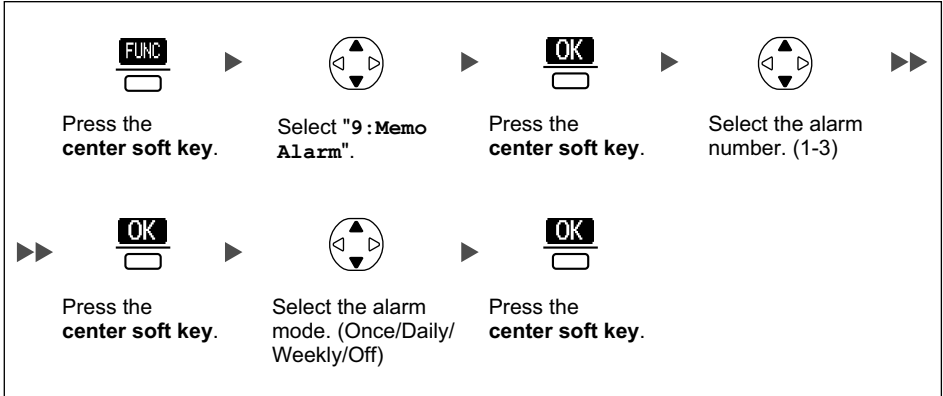

#### [Select the alarm mode-Once/Daily]

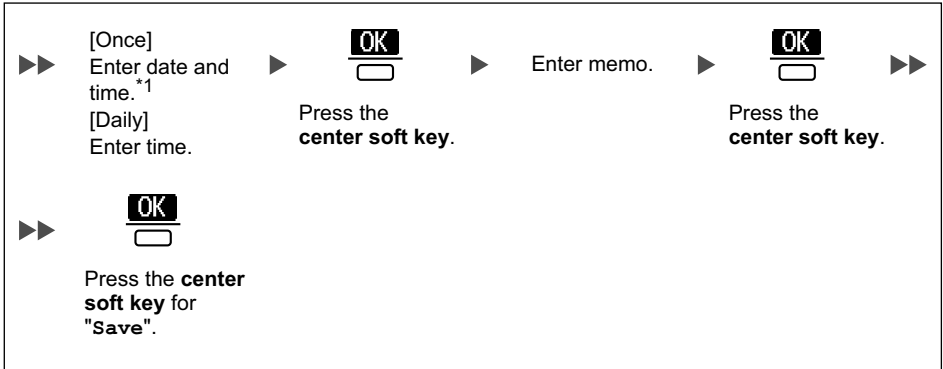

## Configuring Handset Settings

### [Select the alarm mode-Weekly]

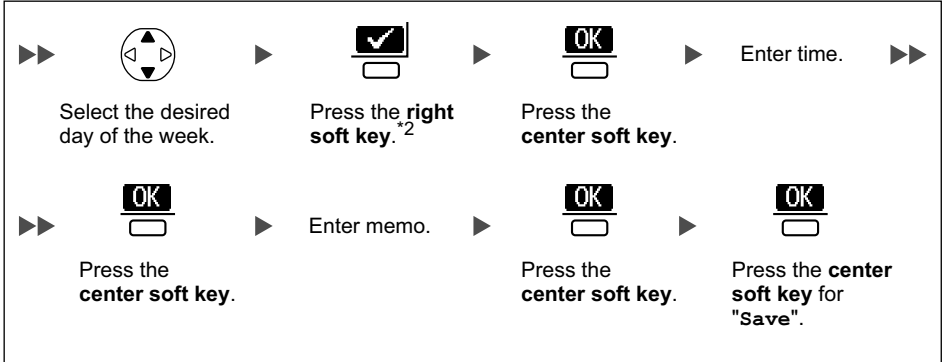

### [Select the alarm mode-Off]



\*1 You can select the format for the date and time. (See "Display Option" on page 62.)

\*2 A "✓" will be displayed next to the day of the week that has been set.

- You can select the ring or vibrate (KX-WT126 only) pattern for each Memo Alarm. (See "Incoming Option" on page 60.)
- If you are on a call at the time that the alarm is set to sound, it will sound after you have ended the call.



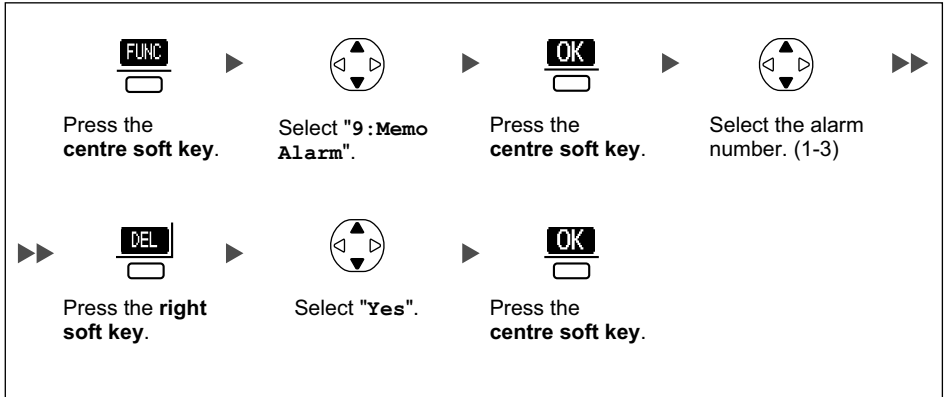

### To delete the alarm mode setting

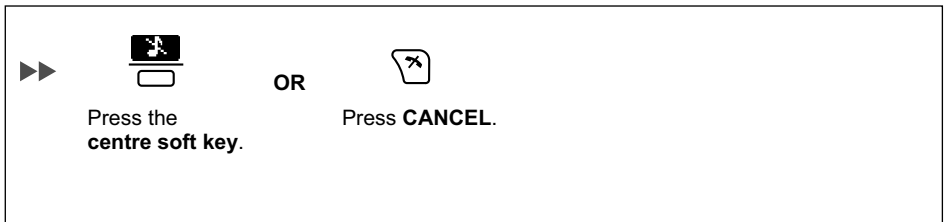

### To stop the alarm



### Troubleshooting

Problem	Possible Cause	Solution
The handset does not work.	The batteries are drained.	Charge the batteries fully. (See "Charging the Batteries" on page 6.)
	The power is off.	Re-insert the batteries and try again. (See "Battery Installation" on page 5.)
The handset does not ring.	Ringer volume is set to "OFF".	Adjust the ringer volume level. (See "Adjusting the Ringer Volume" on page 15.)
	Silent Mode is set to "On", or  is displayed on the LCD.	Press  for more than 2 seconds to cancel the Silent Mode.
You cannot make/receive a call.	The handset is out of range, or the CS is busy.	Move closer to the CS or try again later.
	The radio channel is busy, or a radio communication error occurred.	Try again later.
You cannot dial.	The number that you dialled is restricted by the PBX.	Consult your dealer.
	Key lock mode is on.	To cancel the mode, press  for about 2 seconds.  (See "Key Lock" on page 10.)
	The radio channel is busy or a radio communication error occurred.	Try again later.
The handset stops working during operation.		Re-insert the batteries and try again. (See "Battery Installation" on page 5.)
You cannot use the handset during a power failure.	The handset will not function during a power failure because the PBX stops emitting radiowaves.	

## Troubleshooting and Error Messages

Problem	Possible Cause	Solution
The headset does not work.	A headset tone cannot be heard when receiving an incoming call when the headset is attached.	<ul style="list-style-type: none"> <li>• Make sure the headset ringer setting is set to "On". (See "Incoming Option" on page 60.)</li> <li>• Make sure the headset jack is connected properly. (See "Location of Controls" on page 8.)</li> </ul>
Noise is frequently heard.		<ul style="list-style-type: none"> <li>• Place the handset and CS away from other electrical appliances.</li> <li>• Move closer to the CS.</li> </ul>
Two short beeps are heard during a conversation.	The radio signal is weak.	Move closer to the CS.
You charged the batteries for 7 hours, but the beep tones sound, and  flashes (needs to be charged) after a few telephone calls.	The battery charge contacts may be dirty.	Clean the battery charge contacts without damaging them and charge once more.
	It is time to change the batteries.	Replace with new batteries.
While charging the batteries, the handset and the AC adaptor feel warm.	These are normal conditions.	
"No Service" is displayed, and beep tones are heard.	The handset is out of range.	Move closer to the CS or try again later.
	The CS or PBX is out of service.	Consult your dealer.

### Error Messages

Error Message	Possible Cause	Solution
Register Unit	The handset has been canceled or the handset has not been registered.	Consult your dealer.
No Service	The handset is out of range.	Move closer to the CS.
	The CS is turned off.	Make sure the power cord is connected.
PS Not Connected	The called handset is out of range or is not turned on.	Try again later.
CS Busy	The CS is busy.	Try again later.
Please Wait...	The handset is connecting to the CS or PBX.	Wait for a moment.
Charge Battery	The handset batteries have little charge remaining.	Charge the batteries fully. (See "Charging the Batteries" on page 6.)
Use Rechargeable Battery	The installed batteries are not rechargeable.	Replace the installed batteries with rechargeable ones.
No Entries	<b>When trying to view the Phonebook: No items have been stored. (See "Storing an Item in the Handset Phonebook" on page 42.)</b> <b>When trying to view the Incoming or Outgoing Call Log: No logs have been stored.</b>	
Memory Full	The Phonebook is full and cannot store the new item.	Remove unnecessary data in the Phonebook and try again.
Incorrect Entry	The numbers you entered are invalid.	Recheck your entry (max. 5 digits) and try again.
Need Repair 1 (-2)		Consult your dealer.

## Battery Information

After your Panasonic batteries are fully charged (at 25 °C [77 °F]):

Operation	Operating Time
While in use (Talk)	Up to about 8 h (Voice Clarity: OFF) Up to about 7 h (Voice Clarity: ON)
While not in use (Standby)	Up to about 168 h

- Operating time may be shorter than listed above depending on usage conditions and ambient temperature.
- The handset can receive calls while charging.
- Battery consumption increases when the handset is used out of range ("T" is displayed).
- **Clean the handset and the charger contacts with a soft, dry cloth once a month. Clean more often if the unit is subject to grease, dust or high humidity.** Otherwise the batteries may not charge properly.

### Low Battery Warning

The batteries need to be charged in the following situations:

- "☐" flashes, and the alarm sounds\*<sup>1</sup>.
- "Charge Battery" is displayed. In this situation, the handset cannot be operated.

\*<sup>1</sup> If the low battery warning occurs during a conversation, the call will be automatically disconnected one minute after the alarm sounds.

### Replacing the Batteries

If "☐" flashes after using the phone for a short time, even when the batteries have been fully charged, the batteries should be replaced.

If you replace the batteries before the low battery warnings appears, the battery strength icon may display an incorrect reading. In this case, use the handset as normal with the new batteries installed. To install the batteries, see "Battery Installation" on page 5. When the low battery warning is displayed, charge the batteries for about 7 hours. The battery strength icon will then display the correct reading.

- Please use Panasonic batteries with the service part number HHR-65AAAB only.
- There is a danger of explosion if the battery is incorrectly replaced.



A nickel metal hydride battery that is recyclable powers the product you have purchased.

Please call 1-800-8-BATTERY for information on how to recycle this battery.

# Important Safety Instructions

When using your telephone equipment, basic safety precautions, including those below, should always be followed to reduce the risk of fire, electric shock and injury to persons.

- Do not use the product near water, for example, near a bathtub, wash bowl, kitchen sink, or laundry tub, in a wet basement, or near a swimming pool.
- Do not use the telephone in the vicinity of a gas leak to report the leak.
- Do not mix old and new batteries.

## **SAVE THESE INSTRUCTIONS**

---

## For Your Safety

### **WARNING**

- Do not install the product in any other way than described in relevant manuals.
- For safety reasons, do not physically modify the product or any optional equipment.
- The product may only be installed and serviced by qualified service personnel.
- To prevent possible fire or electric shock, do not expose this product to rain or moisture.
- Follow all warnings and instructions marked on this product.
- Do not place the product on an unstable surface, as a fall may cause serious internal damage.
- The AC adaptor only be connected to the type of electric power supply specified on the charger label. If you are not sure of the type of power supply to your home, consult your dealer or local power company.
- Do not allow anything to rest on the power cord. Do not locate the charger where the power cord may be stepped on or tripped on.
- To reduce the risk of electric shock, do not disassemble this product. Only qualified personnel should service this product. Opening or removing covers may expose you to dangerous voltages or other risks. Incorrect reassembly can cause electric shock.
- Unplug the charger from the AC outlet and have the product serviced by qualified service personnel in the following cases:
  - A. When the power supply cord or plug is damaged or frayed.
  - B. If liquid has been spilled into this product.
  - C. If the product has been exposed to rain or water.
  - D. If the product does not operate according to this manual. Adjust only the controls that are explained in this manual. Improper adjustment of other controls may result in damage and may require service by a qualified technician to restore the product to normal operation.
  - E. If the product has been dropped or damaged.
  - F. If product performance deteriorates.
- Do not insert objects of any kind into this product through openings, as they may touch dangerous voltage points or short out parts that could result in a risk of fire or electric shock. Never spill liquid of any kind on or in the product.



- The use of excessive sound volume through earphones, headphones, or headsets may cause hearing loss.
- Remove the batteries when in the proximity of areas with potentially explosive atmospheres such as fuel/chemical storage facilities or blasting operations.
- Consult the manufacturer of any personal medical devices, such as pacemakers, to determine if they are adequately shielded from external RF (radio frequency) energy. (The product operates in the frequency range of 1,920 MHz to 1,930 MHz and the output peak power level is less than 0.12 W.)
- Do not use the product in health care facilities if any regulations posted in the area instruct you not to do so. Hospitals or health care facilities may be using devices sensitive to external RF (radio frequency) energy.
- Unplug the charger from AC outlet if it emits smoke, an abnormal smell or makes unusual noise. These conditions can cause fire or electric shock. Confirm that smoke has stopped and contact an authorized service center.
- The batteries pose a choking hazard. Keep the batteries out of reach of children.
- This handset earpiece is magnetized and may retain small ferrous objects.

### **CAUTION**

- When you operate this product, the AC outlet should be near the product and easily accessible.
- The product should never be placed near or over a radiator or other heat source.
- Use only the AC adaptor, batteries and charger indicated in this manual.
- Do not dispose of the batteries in a fire. They may explode. Check with local authorities for special disposal instructions.
- Do not open or disassemble the batteries. Released electrolyte is corrosive and may cause burns or injury to the eyes or skin. The electrolyte is toxic if swallowed.
- Exercise care in handling batteries in order not to short the batteries to conductive materials such as rings, bracelets, and keys. The batteries and/or conductor may overheat and cause burns.
- Charge the batteries provided with, or identified for use with, this product only in accordance with the instructions and limitations specified in this manual.
- There is a danger of explosion if the batteries are incorrectly replaced.
- Do not place metal items such as coins or rings on the charger. As they become hot, you might get burnt if you touch them.
- When you leave the product unused for a long period of time, unplug the AC adaptor from the outlet.
- The AC adaptor is used as the main disconnect device. Ensure that the AC outlet is installed near the product and is easily accessible.

### **For Best Performance**

#### **Operating Range**

- The range of operation depends on the topography of your office, weather, or usage conditions, because signals are transmitted between the CS and the handset by radio waves.
- Normally, you get greater range outdoors than indoors. If there are obstacles such as walls, noise may interfere with your telephone calls. In particular, high metal shelves or reinforced concrete walls will restrict your operating range.
- A handset may not work when it is too far from the CS depending on the structure of the building.
- We strongly suggest you hold the bottom half of the handset to ensure better call quality. Because, the antenna is located in the upper half of the handset.

#### **Noise**

Occasional noise or interference may occur due to electromagnetic radiation from objects such as refrigerators, microwave ovens, faxes, TVs, radios, or personal computers. If noise disturbs your telephone calls, keep the handset away from these electrical appliances.

#### **Environment**

- Keep the product away from heating appliances and devices that generate electrical noise, such as fluorescent lamps and motors. These noise sources can interfere with performance of the product.
- Do not place the product in rooms where the temperature is less than 5 °C (41 °F) or greater than 40 °C (104 °F).
- Allow 10 cm (3-15/16 in) clearance around the product for proper ventilation.
- Avoid environments with excessive smoke, dust, moisture, mechanical vibration, shock, or direct sunlight.
- The apparatus is designed to be installed and operated under controlled conditions of ambient temperature and a relative humidity.

#### **Routine Care**

- Unplug the charger from the AC outlet before cleaning.
- Wipe the product with a soft cloth.
- Do not clean the product with abrasive powder or with chemical agents such as benzene or thinner.
- Do not use liquid cleaners or aerosol cleaners.
- Clean the terminal of the charger periodically.

#### **Placement**

- Do not place heavy objects on top of the handset and charger.
- Care should be taken so that objects do not fall onto, and liquids are not spilled into, the product.
- Place the charger on a flat surface. If the charger is mounted on the wall, install it straight.

## **Security Information**

- To avoid unauthorized access to this product:
  - Change the default password.
  - Set a password that is random and cannot be easily guessed.
  - Change the password regularly.
- This telephone communicates using digital signals that are difficult to intercept. However, it is possible that the signals could be intercepted by a third party.
- This product can store your private/confidential information. To protect your privacy/confidentiality, we recommend that you erase the information such as Phonebook or call log from the memory before you dispose, transfer or return the product, or have the product repaired.

Because the call log cannot be accessed once the handset is out of range or has been deregistered, erase the call log before your phone is deregistered.  
For information about deregistering the handset, contact your dealer.
- Set the password when you register the PS to the PBX.
- It is recommended that you lock the phonebook to prevent stored information from being leaked when you carry the PS or if the PS is lost.

### FCC and Other Information

Privacy of communications may not be ensured when using this phone.

#### Radio Frequency Exposure Requirements

This product complies with FCC radiation exposure limits set forth for an uncontrolled environment. To comply with FCC RF exposure requirements, it must be installed and operated in accordance with provided instructions. For handset body-worn operation, this handset must be used with the provided plastic belt clip, which assures no metal parts and minimum of 1.5 cm (9/16 in) spacing from the user's body. This transmitter must not be co-located or operated in conjunction with any other antenna or transmitter.

#### Note

This equipment has been tested and found to comply with the limits for a Class B digital device, pursuant to Part 15 of the FCC Rules. These limits are designed to provide reasonable protection against harmful interference in a residential installation. This equipment generates, uses, and can radiate radio frequency energy and, if not installed and used in accordance with the instructions, may cause harmful interference to radio communications. However, there is no guarantee that interference will not occur in a particular installation. If this equipment does cause harmful interference to radio or television reception, which can be determined by turning the equipment off and on, the user is encouraged to try to correct the interference by one or more of the following measures:

- Reorient or relocate the receiving antenna.
- Increase the separation between the equipment and receiver.
- Connect the equipment to an outlet on a circuit different from that to which the receiver is connected.
- Consult the dealer or an experienced radio/TV technician for help.

This device complies with Part 15 of the FCC Rules. Operation is subject to the following two conditions:

(1) this device may not cause harmful interference, and (2) this device must accept any interference received, including interference that may cause undesired operation.

#### WHEN PROGRAMMING EMERGENCY NUMBERS AND/OR MAKING TEST CALLS TO EMERGENCY NUMBERS:

1. Remain on the line and briefly explain to the dispatcher the reason for the call before hanging up.
2. Perform such activities during off-peak hours, such as early morning or late evening.

#### **CAUTION**

Any changes or modifications not expressly approved by the party responsible for compliance could void the user's authority to operate this product.

### Customer Information

This equipment complies with Part 68 of the FCC rules and the requirements adopted by the ACTA. On the inside of the battery compartment of this equipment is a label that contains, among other information, a product identifier in the format US:ACJ.....  
If requested, this number must be provided to the telephone company.

If trouble is experienced with this equipment, for repair or warranty information, please contact:

Panasonic Service and Technology Company-BTS Center  
415 Horizon Drive Bldg. 300 Ste. 350-B  
Suwanee, GA 30024-3186

If the equipment is causing harm to the telephone network, the telephone company may request that you disconnect the equipment until the problem is resolved.

### Hearing Aid Compatibility

This telephone provides magnetic coupling for hearing aids as defined by the FCC in 47 CFR Section 68.316. Use only handsets or other acoustic devices with this equipment that are compliant with the hearing aid compatibility requirements of FCC Part 68.

When you hold the phone to your ear, noise might be heard in your Hearing Aid. Some Hearing Aids are not adequately shielded from external RF (radio frequency) energy. If noise occurs, use an optional headset accessory or the speakerphone option (if applicable) when using this phone. Consult your audiologist or Hearing Aid manufacturer about the availability of Hearing Aids which provide adequate shielding to RF energy commonly emitted by digital devices.

### Compliance with TIA-1083 standard:



Telephone handsets identified with this logo have reduced noise and interference when used with T-Coil equipped hearing aids and cochlear implants.

## **Important Information**

---

### **For Product Service**

- Panasonic Service Centers are listed in the service center directory.
- Call 1-800-211-PANA (7262) for the location of your nearest authorized service center.
- Panasonic's e-mail address for customer inquiries:  
consumerproducts@panasonic.com  
for customers in the USA and Puerto Rico ONLY

### **To return a product for repair**

Carefully pack and send it prepaid, adequately insured and preferably in the original carton. Attach a postage-paid letter, detailing the symptom, to the outside of the carton. **DO NOT** send the product to the Executive or Regional Sales offices, as they are not equipped to make repairs.

### **Product Service**

Panasonic Factory Service Centers for this product are listed in the service center directory. Consult your certified Panasonic dealer for detailed instructions.

Keep a copy of all important data (such as your Phonebook) before sending the machine for repair.

- This cordless telephone is designed for use in the United States of America. Sale or use of this product in other countries may violate local laws.
- Ce téléphone sans fil est conçu pour être utilisé aux États-Unis d'Amérique. La vente ou l'emploi de cet appareil dans certains autres pays peut constituer une infraction à la législation locale.
- Este teléfono sin cordón fue elaborado para su uso en los Estados Unidos de América. La venta o el empleo de este producto en ciertos países puede constituir una violación de la legislación local.
- このコードレス電話機は、日本国外での使用を目的として設計されており、日本国内での使用は法律違反となります。従って、当社では日本国内においては原則として修理などのサービスは致しかねます。



**For your future reference**

SERIAL NO. \_\_\_\_\_  
(found inside the battery compartment)

DATE OF PURCHASE \_\_\_\_\_

NAME OF DEALER \_\_\_\_\_

DEALER'S ADDRESS \_\_\_\_\_

\_\_\_\_\_

\_\_\_\_\_

\_\_\_\_\_

DEALER'S TEL. NO. \_\_\_\_\_

**Panasonic Corporation of North America**

One Panasonic Way, Secaucus, New Jersey 07094

<http://www.panasonic.com/csd>

**Copyright:**

This material is copyrighted by Panasonic System Networks Co., Ltd., and may be reproduced for internal use only. All other reproduction, in whole or in part, is prohibited without the written consent of Panasonic System Networks Co., Ltd.

© Panasonic System Networks Co., Ltd. 2010