

SAMPLE (2nd draft)
This is NOT the final draft.

Panasonic[®]

Wireless Communication System Center Module

Operating Instructions Model No. WX-CC2010 Series

Digital Technology

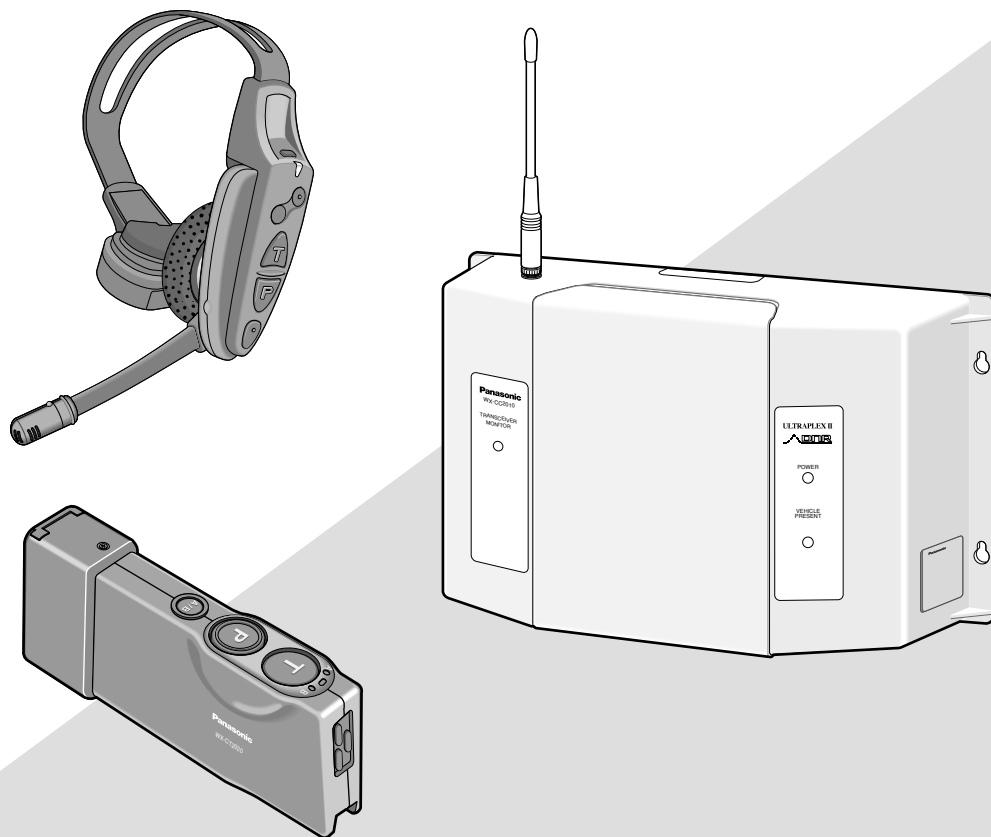

Before attempting to connect or operate this product,
please read these instructions carefully and save this manual for future use.

ENGLISH VERSION

FEDERAL COMMUNICATIONS COMMISSION INTERFERENCE STATEMENT

This equipment has been tested and found to comply with the limits for a Class B digital device, pursuant to Part 15 of the FCC Rules. These limits are designed to provide reasonable protection against harmful interference in a residential installation. This equipment generates, uses and can radiate radio frequency energy and, if not installed and used in accordance with the instructions, may cause harmful interference to radio communications. However, there is no guarantee that interference will not occur in a particular installation. If this equipment does cause harmful interference to radio or television reception, which can be determined by turning the equipment off and on, the user is encouraged to try to correct the interference by one of the following measures:

- Reorient or relocate the receiving antenna.
- Increase the separation between the equipment and receiver.
- Connect the equipment into an outlet on a circuit different from that to which the receiver is connected.
- Consult the dealer or an experienced radio/TV technician for help.

FCC Warning : This transmitter must not be co-located or operated in conjunction with any other antenna or transmitter.

FCC Warning : This equipment complies with FCC radiation exposure limits set forth for uncontrolled equipment and meets the FCC radio frequency (RF) Exposure Guidelines in Supplement C to OET65. This equipment should be installed and operated with at least 20cm and more between the radiator and person's body (excluding extremities: hands, wrists, feet and legs).

FCC Warning: To assure continued FCC emission limit compliance, use only the provided power supply cord and shielded interface cable when connecting this device to the computer. Also, any unauthorized changes or modifications to this equipment would void the user's authority to operate this device.

This device complies with Part 15 of the FCC Rules. Operation is subject to the following two conditions: (1) This device may not cause harmful interference, and (2) this device must accept any interference received, including interference that may cause undesired operation.

Responsible Party: Matsushita Electric Corporation of America
1707 N. Randall Rd., Elgin IL. 60123
Contact Source: Panasonic Consumer Electronics Company
866-472-6767

CAUTION

It is a violation of Federal Law to begin operating this system prior to obtaining an FCC Radio License. The FCC ID number for this radio equipment is listed below.

FCC ID: ACJ9TAWX-CC2010Z

RSS-210

This device has been designed to operate with an antenna having a maximum gain of -3 dB.

Antenna having a higher gain is strictly prohibited per regulations of Industry Canada.

The Required antenna impedance is 50 ohms"

To reduce potential radio interference to other users, the antenna type and its gain should be so chosen that the equivalent isotropically radiated power (EIRP) is not more than that required for successful communication

	CAUTION RISK OF ELECTRIC SHOCK DO NOT OPEN	
<p>CAUTION: TO REDUCE THE RISK OF ELECTRIC SHOCK, DO NOT REMOVE COVER (OR BACK). NO USER-SERVICEABLE PARTS INSIDE. REFER SERVICING TO QUALIFIED SERVICE PERSONNEL.</p>		



The lightning flash with arrowhead symbol, within an equilateral triangle, is intended to alert the user to the presence of uninsulated "dangerous voltage" within the product's enclosure that may be of sufficient magnitude to constitute a risk of electric shock to persons.



The exclamation point within an equilateral triangle is intended to alert the user to the presence of important operating and maintenance (servicing) instructions in the literature accompanying the appliance.

Danger of explosion if battery is incorrectly replaced.
Replace only with the same or equivalent type.

ATTENTION:



A battery that is recyclable powers the product you have purchased. Please call 1-800-8-BATTERY for information on how to recycle this battery.



A lithium-ion battery that is recyclable powers the product you have purchased. Please call 1-800-8-BATTERY for information on how to recycle this battery.

The serial number of this product may be found in the battery compartment of the unit.
You should note the serial number of this unit in the space provided and retain this book as a permanent record of your purchase to aid identification in the event of theft.

Model No. _____
Serial No. _____

WARNING: To prevent fire or electric shock hazard, do not expose this appliance to rain or moisture. The apparatus shall not be exposed to dripping or splashing and that no objects filled with liquids, such as vases, shall be placed on the apparatus.

IMPORTANT SAFETY INSTRUCTIONS

- 1) Read these instructions.
- 2) Keep these instructions.
- 3) Heed all warnings.
- 4) Follow all instructions.
- 5) Do not use this apparatus near water.
- 6) Clean only with dry cloth.
- 7) Do not block any ventilation openings. Install in accordance with the manufacturer's instructions.
- 8) Do not use near any heat sources such as radiators, heat registers, stoves, or other apparatus (including amplifiers) that produce heat.
- 9) Do not defeat the safety purpose of the polarized or grounding-type plug. A polarized plug has two blades with one wider than the other. A grounding-type plug has two blades and a third grounding prong. The wide blade or the third prong are provided for your safety. If the provided plug does not fit into your outlet, consult an electrician for replacement of the obsolete outlet.
- 10) Protect the power cord from being walked on or pinched particularly at plugs, convenience receptacles and the points where they exit from the apparatus.
- 11) Only use attachments/accessories specified by the manufacturer.
- 12) Use only with the cart, stand, tripod, bracket, or table specified by the manufacturer, or sold with the apparatus. When a cart is used, use caution when moving the cart/apparatus combination to avoid injury from tip-overs.



- 13) Unplug this apparatus during lightning storms or when unused for long periods of time.
- 14) Refer all servicing to qualified service personnel. Servicing is required when the apparatus has been damaged in any way, such as power-supply cord or plug is damaged, liquid has been spilled or objects fallen into the apparatus, the apparatus has been exposed to rain or moisture, does not operate normally, or has been dropped.

CONTENTS

IMPORTANT SAFETY INSTRUCTIONS	3
PREFACE.....	5
PRECAUTIONS.....	6
PANASONIC WX-CC2010 SERIES SYSTEM PARTS AND ACCESSORIES	7
MAJOR OPERATING CONTROLS AND THEIR FUNCTIONS	8
■ WX-CC2010 Center Module	8
■ WX-C516 Power Transformer	12
■ WX-C1027A Headset.....	12
■ WX-C550 Speaker Microphone	12
■ WX-CT2020 Order Taker Unit.....	13
PREPARATIONS	15
■ Installations and Connections	15
■ Battery Charge and Replacement (WX-CH2050A/WX-CT2020)	15
■ Setup Procedures (WX-CH2050A/WX-CT2020)	15
■ Preparation	15
■ Maintenance of Headpad Accessories (WX-C1027A: Non-Scheduled)	16
OPERATING PROCEDURES.....	17
TROUBLESHOOTING	17
SPECIFICATIONS.....	18

PREFACE

Panasonic WX-CC2010 Center Module is designed for Panasonic Wireless Communication System, which is used with drive-through menu boards, etc. The system operates on UHF frequencies, and offers multi-channel flexibility making use of the PLL (Phase Locked Loop) technology.

FEATURES

- **A remote speaker can be added to the system.**
- **The order taker unit and all-in-one headset are designed to facilitate the battery installation.**

New Functions of the WX-CC2010 (New Technological Features)

- **New DNR (Digital Noise Reduction)**
The New DNR function provides sound quality without noise that accompanies digital processing. (WX-CC2010 Center Module has the sound quality of customer's voice which has been improved than that of WX-C1011 Center Module.)
- **Talkback Echo Elimination**
Digital delay processing eliminates talkback echo from the order taker unit.
- **TBC (Talkback Automatic Level Control)**
Only human voice is identified in a mixed input of customer's voice and noise from the menuboard microphone. Then, the volume of customer's voice is compared with the talk volume of the order taker unit, and the talkback volume level is automatically controlled.

PRECAUTIONS

This center module is a sensitive device and should be regarded as such. If handled carelessly, the hazard of electric shock may exist.

In order to utilize the instrument to its fullest potential, please consider the following precautions.

1. Handle the equipment with care. This equipment contains sensitive components that can be damaged by improper handling or storage.
2. Refer any servicing to qualified service personnel. Do not attempt to disassemble the center module, order taker unit or other units. In order to prevent electrical shock, do not remove screws or covers. There are no user-serviceable parts inside.
3. Use a dry cloth to clean the center module, order taker unit or other units if soiled or dirty. If necessary, a mild detergent may be used.
4. Take immediate action if the center module or order taker unit becomes wet. Turn the power off and have the unit examined by qualified service personnel. Do not expose the center module or order taker unit to rain or moisture, or attempt to operate the equipment in wet areas. Do not operate the equipment if it is wet.
5. Follow normal safety precautions to avoid personal injury.
6. Properly store the order taker unit (WITH HEADSET PLUGGED IN) in the order taker unit case to prevent damage to equipment.
7. Replace a missing microphone cover and ear speaker cover of the headset with a new one to prevent distortion or loss of audio.
8. Repair or replace any defective components.
9. Turn off the order taker unit when not in use, in order to save the battery life.
10. When the power indicator lights up in red and a pulsing beep tone is heard in the headset, charge battery to the order taker unit (if using WX-CT2020 in combination with WX-C1027A) or all-in-one headset (if using WX-CH2050A).
11. Clean the battery charger of the order taker unit or all-in-one headset in accordance with manufacturer instructions at least once a month. (Refer to the operating instructions of the battery charger.)
12. Perform regular preventive maintenance by testing accessories (headset and batteries, etc.)

PANASONIC WX-CC2010 SERIES SYSTEM PARTS AND ACCESSORIES

Note: Illustrations may differ from actual products.

■ Center Module
WX-CC2010

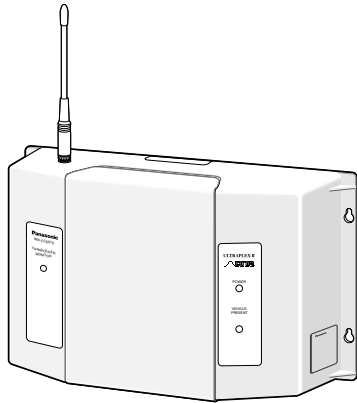

■ All in One Headset
WX-CH2050A



■ Order Taker Unit
WX-CT2020



■ Headset
WX-C1027A

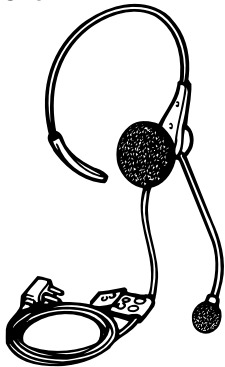

■ Speaker Microphone
WX-C550

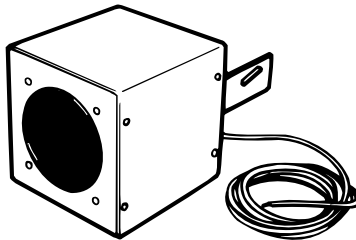

■ Vehicle Detector 917-1
(Locally Procured)

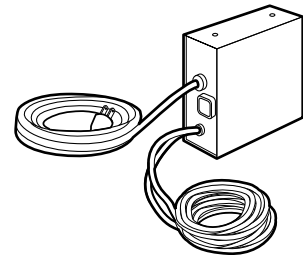

■ Speaker/Loop Cable Kit
WX-C688

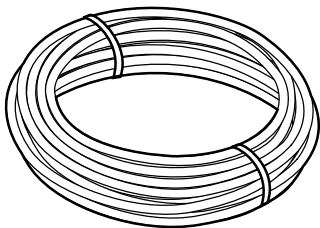

■ Power Transformer
WX-C516

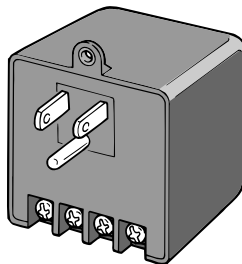

■ Order Taker Unit Case
WX-CT2022

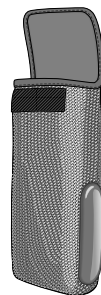

■ Rechargeable Battery
For WX-CH2050A: 2050BAT or 2051BAT
For WX-CT2020: 2020BAT

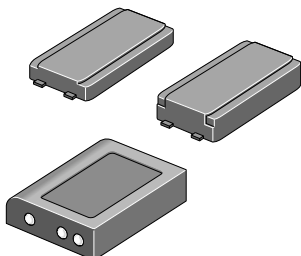

■ Battery Charger
For WX-CH2050A: 2050CH
For WX-CT2020: 2020CH

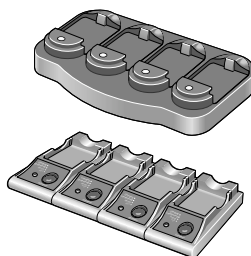

MAJOR OPERATING CONTROLS AND THEIR FUNCTIONS

■ WX-CC2010 Center Module

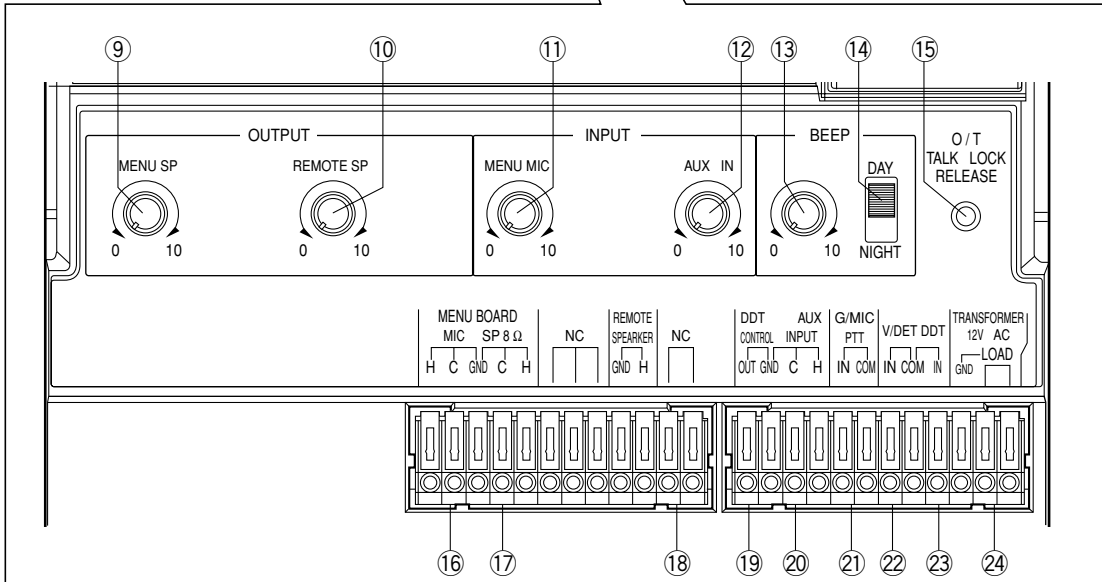
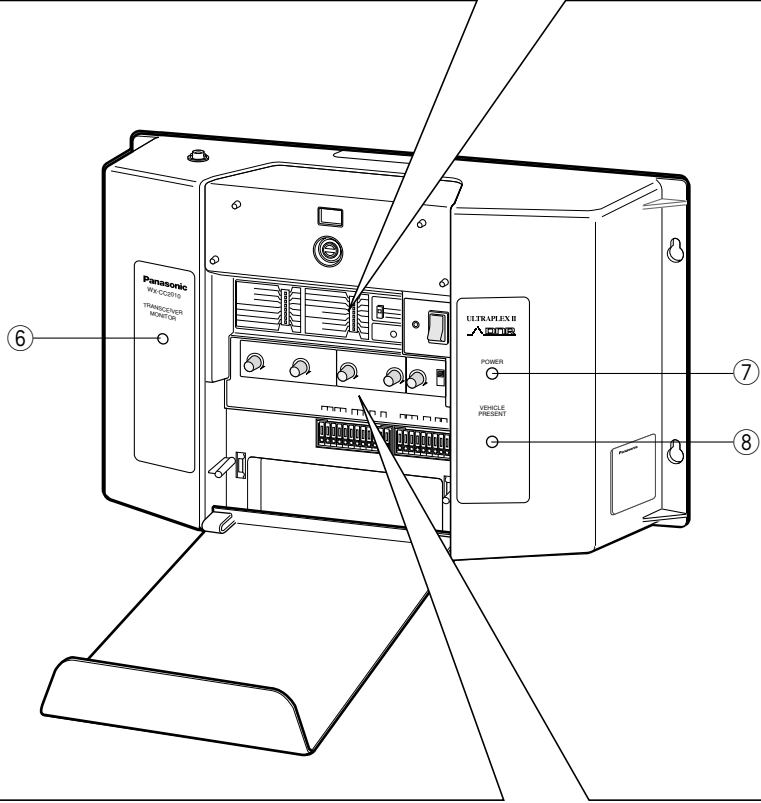
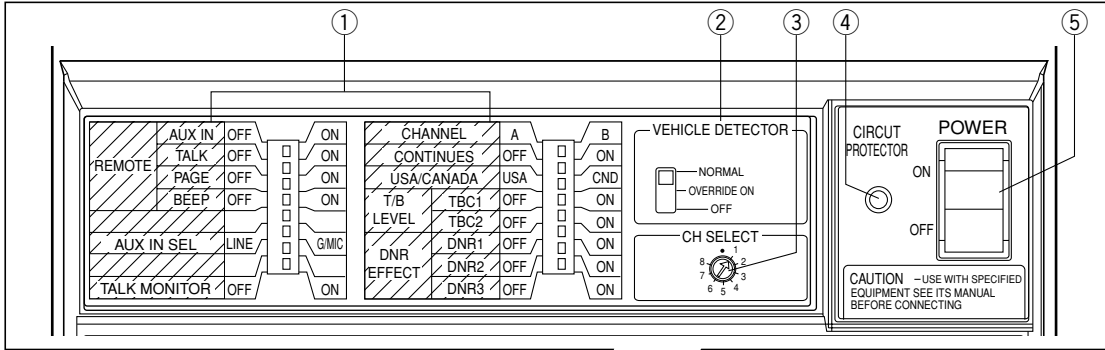

Notes:

- The following switches and terminals should be used by qualified service personnel or system installers only.
- To change the setting of the following switches, turn off the power of the center module, then turn it back on.

① **Auxiliary Input On/Off Switch (REMOTE AUX IN, ON/OFF)**

Set this switch to ON to output the audio (that has been input from the AUX INPUT terminals) to the REMOTE SPEAKER terminals.

Talk On/Off Switch (REMOTE TALK, ON/OFF)

To monitor the conversation between the store personnel and customer with the remote speaker, set this switch to ON.

Page On/Off Switch (REMOTE PAGE, ON/OFF)

To monitor the conversation among the store personnel with the remote speaker, set this switch to ON.

Beep On/Off Switch (REMOTE BEEP, ON/OFF)

Set this switch to ON to output beep sounds to the remote speakers.

Auxiliary Input Selection Switch (AUX IN SEL, G MIC/LINE)

Note: "G MIC" is marked as "G/MIC" on the switch panel.

This switch selects the auxiliary input level.

G MIC (Gooseneck Microphone)

This can be used as a wired system.

Input : -62 dBV, balanced

LINE

Input : -20 dBV, balanced

Talk Monitor On/Off Switch (TALK MONITOR, ON/OFF)

This switch should be normally set to OFF.

Consult your servicing dealer before attempting to change this switch.

Channel Selection Switch (CHANNEL, A/B)

This switch selects the frequency between channel A and B licensed by the FCC. This switch is normally set to A. The switch can be set to B if external interference occurs.

Continuous Transmission On/Off Switch (CONTINUES, ON/OFF)

ON: When the switch is set to ON, the transmission starts by turning on the power of center module.

OFF: When the switch is set to OFF, the transmission starts with the following conditions.

- The VEHICLE DETECTOR switch has been set to NORMAL or OVERRIDE ON.
- The button P or T on the order taker unit has been pressed.

USA/Canada Switch (USA/CANADA, USA/CND)

To select a radio frequency suitable for the region, set this switch as follows.

USA: This setting is available in the United States.

CND: This setting is available in Canada.

Talkback Level Control Switch (T/B LEVEL: TBC1, TBC2, ON/OFF)

These switches are used for the talkback level setting of the order taker unit.

Change the settings if the talkback level is too high.

Setting	Talkback Level	Remarks
<input type="checkbox"/> TBC1 <input type="checkbox"/> TBC2	-6 dB	Normally set to this position. Talkback level set to 50 %.
<input type="checkbox"/> TBC1 <input type="checkbox"/> TBC2	-9 dB	Talkback level set to 35 %.
<input type="checkbox"/> TBC1 <input type="checkbox"/> TBC2	-12 dB	Talkback level set to 25 %.
<input type="checkbox"/> TBC1 <input type="checkbox"/> TBC2	-	Talkback is off.

Note: These settings are activated when the DNR switch is set to ON.

DNR (Digital Noise Reduction) Effect Level Control Switch

(DNR EFFECT: DNR1, DNR2, DNR3, ON/OFF)

These switches are used for the noise reduction level setting.

The more the noise is reduced, the lower the sound quality will be. The following table shows the relationship between noise reduction level and sound quality.

Note: No setting should be done other than shown in the table.

Setting	Noise Reduction Level	Sound Quality	Remarks
<input type="checkbox"/> DNR1 <input type="checkbox"/> DNR2 <input type="checkbox"/> DNR3	—	—	No DNR processing
<input type="checkbox"/> DNR1 <input type="checkbox"/> DNR2 <input type="checkbox"/> DNR3	Low	High	For a relatively quiet environment
<input type="checkbox"/> DNR1 <input type="checkbox"/> DNR2 <input type="checkbox"/> DNR3	Normal	Normal	For a general environment This setting is recommended.
<input type="checkbox"/> DNR1 <input type="checkbox"/> DNR2 <input type="checkbox"/> DNR3	High	Low	For a very noisy environment Not recommended because it affects sound quality.

② **Vehicle Detector Normal/Override On/Off Switches (VEHICLE DETECTOR, NORMAL/OVERRIDE ON/OFF)**

NORMAL: The vehicle detector turns on only when a vehicle is detected at the menu board. When the detector is turned on, a beep tone is heard in the headset. After the beep tone, the menuboard speaker turns on to allow the communication with the customer. When the vehicle leaves, the vehicle detector turns off.

OVERRIDE ON: The vehicle detector is always turned on.

OFF: Vehicles are not detected at the menuboard. No beep tone is heard in the headset, and the menuboard speaker remains off.

③ **Channel Group Selection Switch (CH SELECT, 1 to 8)**

This switch selects the group from 8 positions.

Note: Do not set this switch to positions other than 1 to 8. That will result in an error.

④ **Circuit Protector button (CIRCUIT PROTECTOR)**

If excessive current flows to the center module, the circuit protector is triggered. When this button is sticking out, turn off the POWER switch, press this CIRCUIT PROTECTOR button, and turn on the POWER switch again.

If the circuit protector is soon triggered again, consult your dealer or authorized service center for assistance.

⑤ **Power On/Off Switch (POWER, ON/OFF)**

This switch turns the power of the center module on and off.

Channel Monitor

Channel Monitor is the mode to check if other devices have already used the desired channel at the time of the installation. The following is how to activate Channel Monitor.

When you set the POWER switch to ON while holding down the O/T TALK LOCK RELEASE switch, Channel Monitor is activated. To return to the default mode, turn off and on the power again with the POWER switch.

⑥ **Talk/Page Indicator (TRANSCIVER MONITOR, Red/Green/Amber)**

Red: When the order taker unit is in the Talk PTT/Talk Lock mode, the indicator lights up in red.

Green: When the order taker unit is in the Page PTT/Page Lock mode, the indicator lights up in green.

Amber: When the gooseneck microphone is enabled, the indicator lights up in amber.

⑦ **Power Indicator (POWER) (Green)**

This indicates that the power of center module is on.

⑧ **Vehicle Detector Indicator (VEHICLE PRESENT) (Amber)**

This indicates that a vehicle has been detected.

⑨ **Menuboard Speaker Volume Control (MENU SP, 0 to 10)**

This control sets the output level of Menuboard Speaker to the optimum level for speaking to the customer.

Notes:

- Adjust this control after you set the VEHICLE DETECTOR switch to OVERRIDE ON and the vehicle detector indicator lights up. Otherwise, you cannot adjust the volume level.
- The line marked on this control is a standard position for this adjustment. Adjust this control to the suitable position so that feedback does not occur.

⑩ **Remote Speaker Volume Control (REMOTE SP, 0 to 10)**

This control sets the output level of Remote Speaker to the optimum level.

Notes:

- Adjust this control after you set the VEHICLE DETECTOR switch to OVERRIDE ON and the vehicle detector indicator lights up. Otherwise, you cannot adjust the volume level.
- The line marked on this control is a standard position for this adjustment. Adjust this control to the suitable position so that feedback does not occur.

⑪ **Menuboard Microphone Volume Control (MENU MIC, 0 to 10)**

This control sets the input level of Menuboard Microphone to the optimum level.

Notes:

- Adjust this control after setting the VEHICLE DETECTOR switch to OVERRIDE ON and the vehicle detector indicator lights up. Otherwise, you cannot adjust the volume level.
- The line marked on this control is a standard position for this adjustment. Adjust this control to the suitable position so that feedback does not occur.

⑫ **Auxiliary Input Level Control (AUX IN, 0 to 10)**

This controls the input level of the AUX INPUT terminals.

⑬ **Vehicle Detector Beep Volume Control (BEEP, 0 to 10)**

This control sets the vehicle-detection beep tone for the order taker unit to the optimum level. When the VEHICLE DETECTOR switch is set to NORMAL, turning this control changes the beep tone level of the remote speaker.

14 Day/Night Selection Switch (DAY/NIGHT)

In the Day mode, you will not hear the beep tone of the other lane in the headset that sounds when the vehicle detector is on and that sounds when you press the button T of the order taker unit.

In the Night mode, you will hear the beep tone of either lane in the headset when the vehicle detector of either lane is on. Once you press the button T, you will no longer hear your lane's beep tone. However, you will continue to hear the other side's beep tone when the other side vehicle detector is on, until the button T of the other side's order taker unit is pressed.

Note: The following is the beep patterns.

Beep A: Pi...Pi...

Beep B: PiPi...PiPi...

Beep C: Pi..PiPi...Pi..PiPi...

State of lane	Order taker unit	Day mode	Night mode
Vehicle detector at Lane A is ON.	A	Beep A	Beep A
	B	Beep A	Beep A
Vehicle detector at Lane B is ON.	A	Beep B	Beep B
	B	Beep B	Beep B
Vehicle detectors of both lanes are ON.	A	Beep C (When you press the button T, the beep tone will be deactivated.)	Beep C (When you press the button T, Beep C will change to Beep B.)
	B	Beep C (When you press the button T, the beep tone will be activated.)	Beep C (When you press the button T, Beep C will change to Beep A.)

15 Order Taker Unit Talk Lock Release Switch (O/T TALK LOCK RELEASE)

This switch is used to release temporarily the talk lock mode of the order taker unit.

16 Menuboard Microphone Terminals (MENU BOARD MIC: H, C, GND)

These terminals are used for the connection with Menuboard Microphone (Speaker Microphone WX-C550).

The audio level is -61 dBV, 8 Ω, balanced.

17 Menuboard Speaker Terminals (MENU BOARD SP 8 Ω: H, C, GND)

These terminals are used for the connection with Menuboard Speaker (Speaker Microphone WX-C550).

The audio level is 8 Ω, 3 W, unbalanced.

18 Remote Speaker Terminals (REMOTE SPEAKER: H, GND)

These terminals are used for the connection with Remote Speaker.

The audio level is 8 Ω, 3 W, unbalanced.

Note: The remote speaker is a locally procured accessory.

19 Double Drive Through Control Output Terminals (DDT CONTROL: OUT, GND)

To compose Double Drive Through of two center modules, these terminals are used for the connection with the DDT (IN, COM) terminals of the other center module.

- The DDT CONTROL OUT terminal is connected with the DDT IN terminal of the other center module.
- The DDT CONTROL GND terminal is connected with the DDT COM terminal of the other center module.

20 Auxiliary Input Terminals (AUX INPUT: H, C, GND)

These terminals are used for the connection with the line or the connection with a gooseneck microphone.

Note: When connecting the gooseneck microphone, set the AUX IN SEL switch to G/MIC.

21 Gooseneck Microphone PTT Terminals (G/MIC PTT: IN, COM)

These terminals are used for the connection with the PTT cable of a gooseneck microphone (locally procured).

22 Vehicle Detector Terminals (V/DET: IN, COM)

These terminals are used for the connection with the output terminal of vehicle detector.

23 Double Drive Through Control Input Terminals (DDT: IN, COM)

To compose Double Drive Through of two center modules, these terminals are used for the connection with the DDT CONTROL (OUT, GND) terminals of the other center module.

- The DDT IN terminal is connected with the DDT CONTROL OUT terminal of the other center module.
- The DDT COM terminal is connected with the DDT CONTROL GND terminal of the other center module.

24 Transformer Terminals (TRANSFORMER 12V AC: GND, LOAD)

These terminals are used for the connection with WX-C516 Power Transformer.

■ WX-C516 Power Transformer

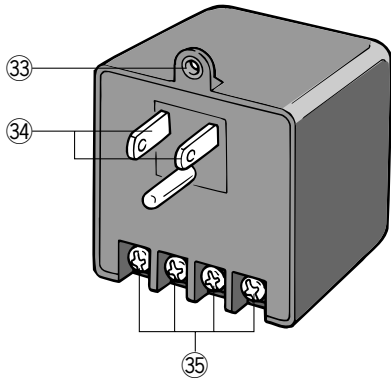

33 Mounting Hole

This hole is used for mounting the power transformer onto the wall plates.

34 Power Plug

To prevent fire or electrical shock, connect this directly to a 3-plug grounded receptacle of 120 V AC, 60Hz.

35 Output terminal (SPARE, AC, AC, GND)

12 V AC, 1 600 mA (UL Listed) is provided at the two terminals (indicated as "AC") to be used for the center module.

Caution:

Be sure to connect the wire between the GND (GROUND) of this terminal and that in the transformer terminal on the center module.

To prevent fire or electrical shock, the UL listed power supply cord (Style SVT) should be used for the cable for 12 V AC terminal.

■ WX-C1027A Headset

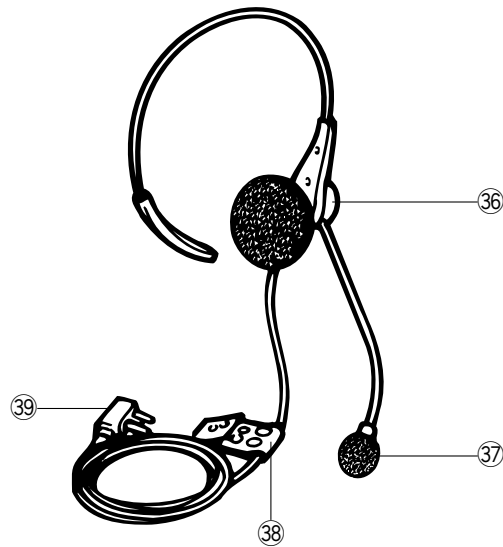

36 Earphone

37 Microphone

38 Cable Clips

Use these clips to attach the cable to your uniform.

39 Headset Plug

■ WX-C550 Speaker Microphone

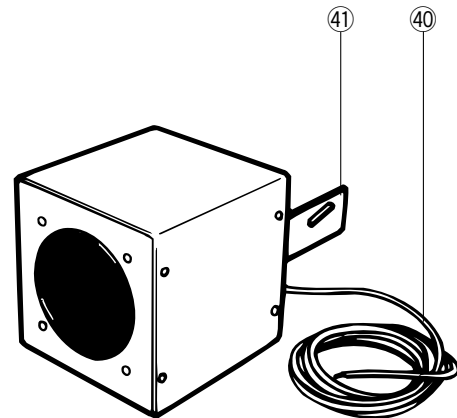

40 Input Cord

A pigtail cord is provided for the speaker input. Its length is approx. 3 meters.

41 Mounting Bracket

AU-type mounting bracket with screw holes is provided as a standard accessory with the WX-C550.

■ WX-CT2020 Order Taker Unit

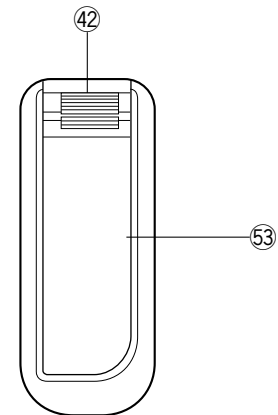
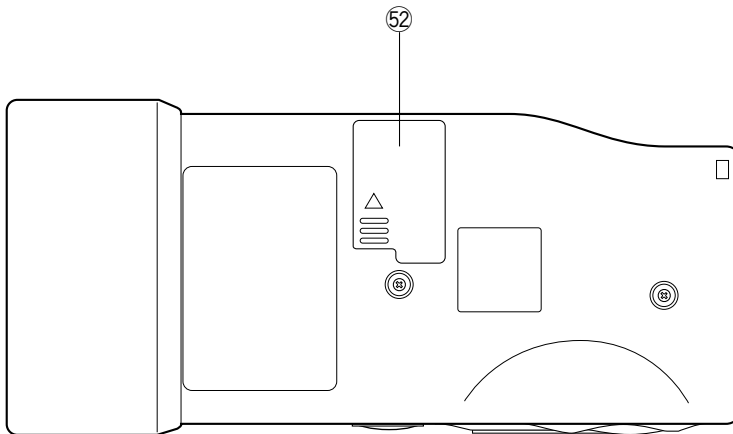
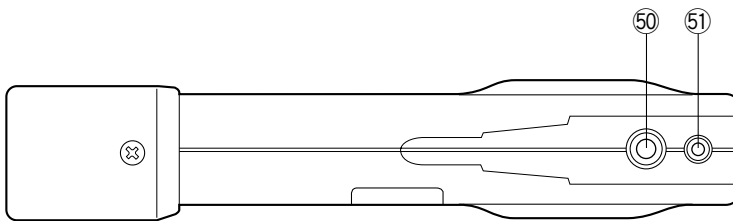
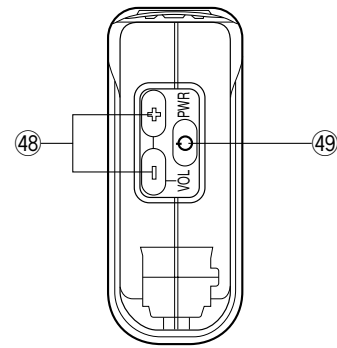
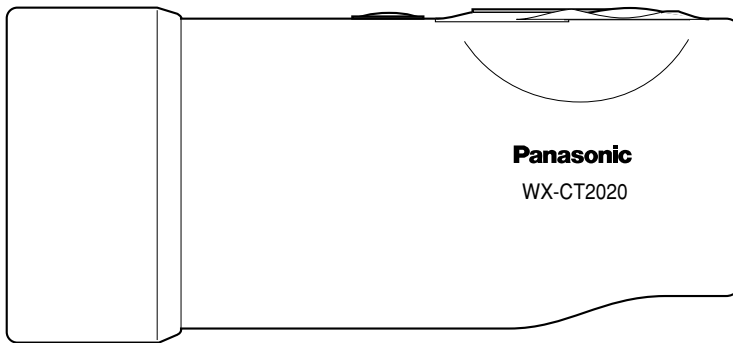
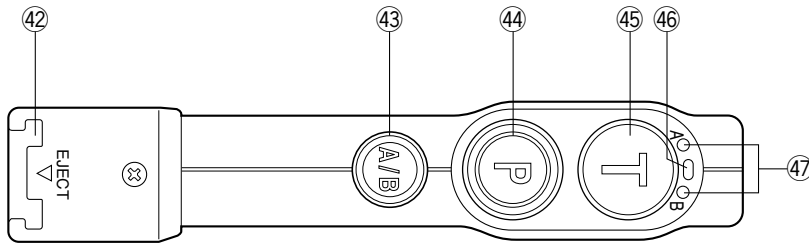

- ④② **Battery Lock (EJECT)**
- ④③ **A/B Channel Selection Button (A/B)**
- ④④ **Page Button (P)**
- ④⑤ **Talk Button (T)**
- ④⑥ **Power Indicator**
- ④⑦ **Channel Indicator**
- ④⑧ **Volume Control Buttons (VOL ◀ ▶)**
- ④⑨ **Power Button**
- ⑤⑩ **Earphone Input Jack**
- ⑤① **Microphone Input Jack**
- ⑤② **Switch Pocket**
- ⑤③ **Battery (Optional accessory)**

PREPARATIONS

■ Installations and Connections

Refer to qualified service personnel for details.

■ Battery Charge and Replacement (WX-CH2050A/WX-CT2020)

Refer to WX-CT2020/WX-CH2050A Operating Instructions for details.

■ Setup Procedures (WX-CH2050A/WX-CT2020)

Note: Setup of WX-CC2010 should only be performed by qualified service personnel or system installers.

● Opening the Switch Pocket

Refer to WX-CT2020/WX-CH2050A Operating Instructions for details.

● Channel Group Selection

Refer to p. 18 for the frequency table.

OFF: The person is assigned as assistant personnel.

● DIP Switch Setup

Refer to WX-CT2020/WX-CH2050A Operating Instructions for details.

● Channel Interference Check

Refer to WX-CT2020/WX-CH2050A Operating Instructions for details.

■ Preparation

Note: The following procedure applies when using WX-CT2020 Order Taker Unit and WX-C1027A Headset. If you use WX-CH2050A All-in-One Headset, refer to the operating instructions of the headset.

1. After loading a battery into the order taker unit, insert the headset plug into the earphone input jack and microphone input jack on the order taker unit.

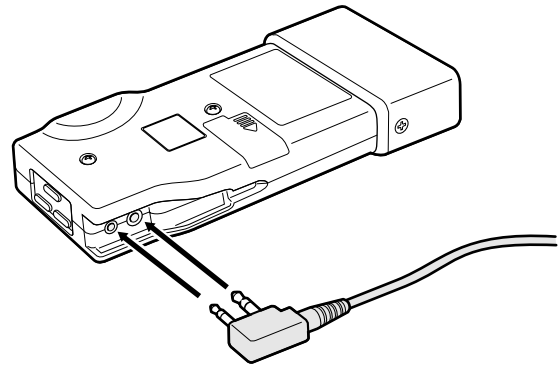

Note: Confirm that the plug has completely been inserted into the jack.

2. Position the microphone boom and wear the order taker unit case as shown in the figure.



■ Maintenance of Headpad Accessories (WX-C1027A: Non-Scheduled)

Notes:

- The following procedure applies when using WX-C1027A Headset. If you use WX-CT2020 Order Taker Unit, refer to the operating instructions of the headset.
- Be sure to use the microphone cover/windproof cushion for WX-C1027A Headset. Otherwise, the headset may be damaged by dust or oil.

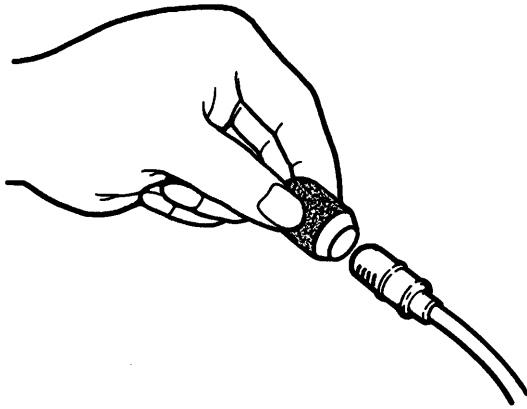

Microphone Cover Replacement

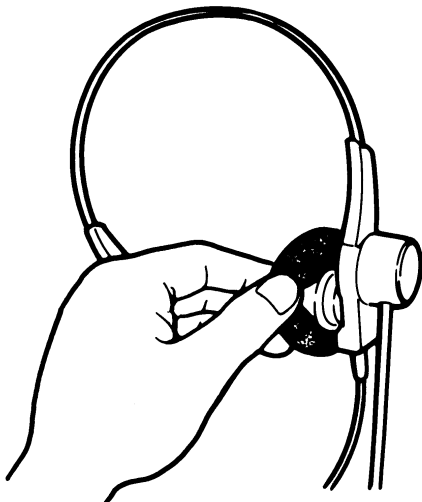

Earspeaker Cover Replacement

Replacement of covers and cushion of headset

The earspeaker cover and microphone cover are washable. After cleaning, make sure they are dry. Then, return the earspeaker cover and microphone cover to the headset.

Be careful when you slip it on or off the earpiece.

The earspeaker cover, microphone cover and headpad cushion are replaceable for sanitary purposes. To order WX-C1025A Headset Cover Kit, refer to the dealer.

Note: A microphone cover must be used at all times.

Failure to do so can cause debris to accumulate in the microphone port opening and result in an inoperative headset.

Headpad Cushion Replacement

1. Peel off the old cushion.
2. Clean the surface with a warm solution of household cleaner.
3. Remove the protective tape from the new cushion.
4. Position the new cushion on the headpad and press in place.

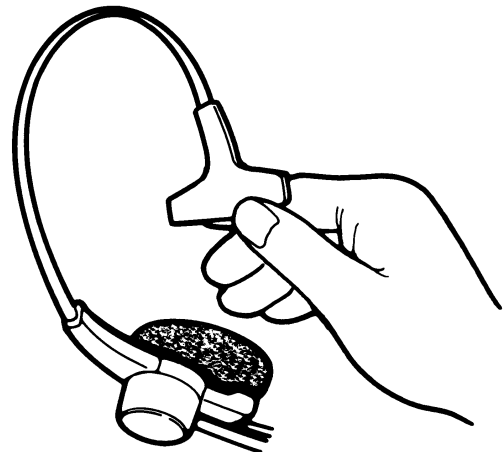

Headpad Cushion Replacement

OPERATING PROCEDURES

Refer to WX-CT2020/WX-CH2050A Operating Instructions for details.

TROUBLESHOOTING

Problem	Check item
The communication between the order taker units and menu board cannot be established. (The TRANSCEIVER MONITOR indicator is not blinking in red.)	<ul style="list-style-type: none"> • Is the POWER switch on the center module turned on? (Refer to p. 10.) • Check the AC power outlet. • Push the CIRCUIT PROTECTOR button. (Refer to p. 10.) • Refer to the dealer or qualified service personnel.
The communication between the order taker units and menu board cannot be established. (The TRANSCEIVER MONITOR indicator is blinking in red.)	<ul style="list-style-type: none"> • Is the CH SELECT switch set to 1 to 8? • If the problem remains even after trying the above, refer to the dealer or service personnel. (Refer to p. 10.)
Cannot communicate with the customer at the menu board (TALK), though the communication among personnel is O.K (PAGE is OK).	<ul style="list-style-type: none"> • Check to see if the VEHICLE PRESENT indicator of the center module lights up when a vehicle drives up the speaker post or menu board. • If the indicator does not light up, check the following. <ol style="list-style-type: none"> 1. Is the vehicle detector plugged in? 2. Check the AC outlet and fuse of the vehicle detector. If the power and fuse are normal, refer to the qualified service personnel.
A menuboard speaker is always live, even when there is no car beside the menu board.	<ul style="list-style-type: none"> • Reset the vehicle detector. If the problem still remains, remove and reinstall the fuse from the detector. (Refer to the operating instructions of the vehicle detector.) • If the problem remains even after trying the above, refer to the dealer or service personnel.
TALK (Talk PTT or Talk Lock mode) or PAGE (Page PTT or Page Lock mode) is unavailable in certain areas.	<ul style="list-style-type: none"> • Confirm that there is no metal obstruction blocking around the center module. • It may be necessary to extend one or both antennas to areas where the reception is error. (Refer to qualified service personnel or system installers.)

SPECIFICATIONS

WX-CC2010 Center Module

Operating Frequency:	Transmit; 468.6125 MHz - 469.3875 MHz Receive; 463.6125 MHz - 464.3875 MHz
Type of Emission:	F3
Type of Antenna:	1/4 wavelength whip antenna
Power Supply:	12 V AC, 60 Hz (Using WX-C516 Power Transformer)
Power Consumption:	10 W
Menuboard Speaker A and B Output:	3 W, 8 Ω
Remote Speaker A and B Output:	3 W, 8 Ω
Vehicle Detector Input:	Normally Open (close contact requires vehicle presence)
Dimensions:	330 mm (W) X 214 mm (H) X 82 mm (D) {13 in. (W) X 8-7/16 in. (H) X 3-15/64 in. (D)}
Weight (Including Antenna):	1.6 kg (3.5 lbs.)
Ambient operating temperature:	-10 °C to +50 °C {14 °F to 122 °F}

Dimensions and weights indicated are approximate.
Specifications are subject to change without notice.

CM:Center Module (WX-CC2010)
OT:Order Taker Unit (WX-CT2020 or WX-CH2050A)

Frequency table

CM: Receive Freq. OT: Transmit Freq.	CM: Transmit Freq. OT: Receive Freq.	USA								CANADA							
		Frequency Group								Frequency Group							
		G1	G2	G3	G4	G5	G6	G7	G8	G1	G2	G3	G4	G5	G6	G7	G8
463.6125MHz	468.6125MHz									A							
463.6375MHz	468.6375MHz										A						
463.6625MHz	468.6625MHz											A					
463.6875MHz	468.6875MHz												A				
463.7125MHz	468.7125MHz													A			
463.7375MHz	468.7375MHz														A		
463.7625MHz	468.7625MHz															A	
463.7875MHz	468.7875MHz																A
463.8125MHz	468.8125MHz									B							
463.8375MHz	468.8375MHz										B						
463.8625MHz	468.8625MHz											B					
463.8875MHz	468.8875MHz												B				
463.9125MHz	468.9125MHz													B			
463.9375MHz	468.9375MHz														B		
463.9625MHz	468.9625MHz															B	
463.9875MHz	468.9875MHz																B
464.0125MHz	469.0125MHz	A															
464.0375MHz	469.0375MHz		A														
464.0625MHz	469.0625MHz			A													
464.0875MHz	469.0875MHz				A												
464.1125MHz	469.1125MHz					A											
464.1375MHz	469.1375MHz						A										
464.1625MHz	469.1625MHz							A									
464.1875MHz	469.1875MHz								A								
464.2125MHz	469.2125MHz	B															
464.2375MHz	469.2375MHz		B														
464.2625MHz	469.2625MHz			B													
464.2875MHz	469.2875MHz				B												
464.3125MHz	469.3125MHz					B											
464.3375MHz	469.3375MHz						B										
464.3625MHz	469.3625MHz							B									
464.3875MHz	469.3875MHz								B								

Panasonic Digital Communications & Security Company

Unit of Matsushita Electric Corporation of America

Security Systems Group

www.panasonic.com/cctv

Executive Office: One Panasonic Way 3E-7, Secaucus, New Jersey 07094

Zone Office

Eastern: One Panasonic Way, Secaucus, NJ 07094 (201) 348-7303

Central: 1707 N.Randal Road, Elgin, IL 60123 (847) 468-5205

Western: 6550 Katella Ave., Cypress, CA 90630 (714) 373-7840

PANASONIC CANADA INC.

5770 Ambler Drive, Mississauga,
Ontario, L4W 2T3 Canada (905)624-5010

PANASONIC SALES COMPANY

DIVISION OF MATSUSHITA ELECTRIC OF PUERTO RICO INC.

San Gabriel Industrial Park 65th Infantry Ave. KM. 9.5 Carolina,
P.R. 00985 (809)750-4300