

**SAMPLE**

# Panasonic

## Order Taker Unit Operating Instructions

Model No. **WX-CT2020**

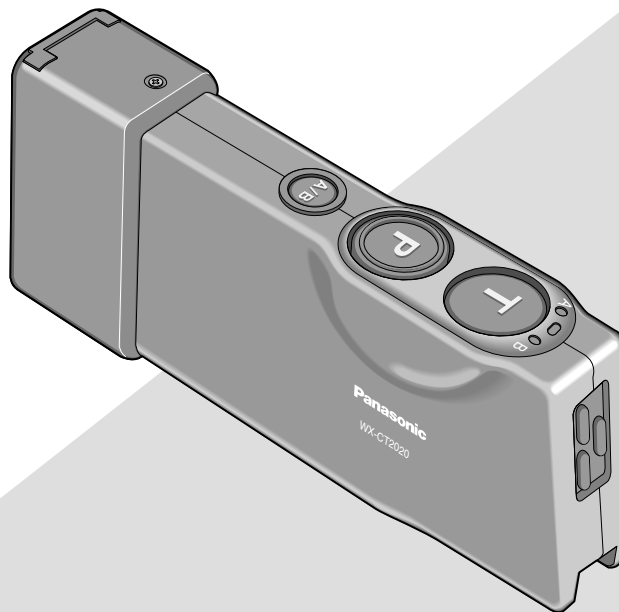

Before attempting to connect or operate this product,  
please read these instructions carefully and save this manual for future use.

## FEDERAL COMMUNICATIONS COMMISSION INTERFERENCE STATEMENT

This equipment has been tested and found to comply with the limits for a Class A digital device, pursuant to part 15 of the FCC Rules. These limits are designed to provide reasonable protection against harmful interference when the equipment is operated in a commercial environment. This equipment generates, uses, and can radiate radio frequency energy and, if not installed and used in accordance with the instruction manual, may cause harmful interference to radio communications. Operation of this equipment in a residential area is likely to cause harmful interference in which case the user will be required to correct the interference at his own expense.

FCC Warning: To assure continued FCC emission limit compliance, use only the provided power supply cord and shielded interface cable when connecting this device to the computer. Also, any unauthorized changes or modifications to this equipment would void the user's authority to operate this device.

This device complies with Part 15 of the FCC Rules. Operation is subject to the following two conditions: (1) This device may not cause harmful interference, and (2) this device must accept any interference received, including interference that may cause undesired operation.

Responsible Party: Matsushita Electric Corporation of America  
1707 N. Randall Rd., Elgin IL. 60123  
Contact Source: Panasonic Digital Communications & Security Company  
866-472-6767

## CAUTION

It is a violation of Federal Law to begin operating this system prior to obtaining an FCC Radio License. The FCC ID number for this radio equipment is listed below.

FCC ID: ACJ9TAWX-CT2020

Danger of explosion if battery is incorrectly replaced.  
Replace only with the same or equivalent type.

## ATTENTION:



A battery that is recyclable powers the product you have purchased. Please call 1-800-8-BATTERY for information on how to recycle this battery.

The serial number of this product may be found in the battery compartment of the unit.  
You should note the serial number of this unit in the space provided and retain this book as a permanent record of your purchase to aid identification in the event of theft.

Model No. WX-CT2020

Serial No. \_\_\_\_\_

# CONTENTS

CONTENTS .....	3
INTRODUCTION .....	3
FEATURES .....	3
PRECAUTIONS .....	3
NAMES & FUNCTIONS .....	4
BATTERY LOADING & REPLACEMENT .....	6
● Loading .....	6
● Replacement .....	6
SETUP PROCEDURES .....	6
● Opening the Switch Pocket .....	6
● Channel Group Selection .....	7
● DIP Switch Setup .....	7
● Channel Interference Check .....	7
● Operation Mode Setup .....	9
OPERATING PROCEDURES .....	11
● Turning the Power On/Off .....	11
● Communications with Customers (TALK) .....	11
● Communications with Other Store Personnel (PAGE) .....	12
WHEN DISCONNECTING THE HEADSET PLUG .....	12
TROUBLESHOOTING .....	13
SPECIFICATIONS .....	14
STANDARD ACCESSORIES .....	14
OPTIONAL ACCESSORIES .....	14

## INTRODUCTION

Panasonic WX-CT2020 Order Taker Unit is designed for the use in Panasonic Wireless Communication System. Using with WX-C1027A Headset (option), you can communicate by voice with other store personnel and the customer.

## FEATURES

- Compatible center modules: WX-C1010, WX-C1011, and WX-CC2010 (Refer to "SW#8" on p. 7 "DIP Switch Setup".)
- Noise and interference reduction by use of UHF band
- Facilitated frequency setting by use of phase lock loop (PLL)
- A/B channel selection available for double drive-through (DDT) (Refer to "SW#2" on p. 7 "DIP Switch Setup".)
- Talk mode selectable between Talk Lock and Talk PTT (Refer to p. 9 "Optional Mode Setup".)
- Page mode selectable between Page Lock and Page PTT (Refer to p. 9 "Optional Mode Setup".)

## PRECAUTIONS

- All setup procedures of this product should be performed by qualified service personnel or system installers.
- Use only Panasonic authorized batteries like the rechargeable Ni-MH 3.6 V.
- Follow the battery care and handling instructions.
- Read the instructions included with the battery charger.
- Charge the battery when the power indicator lights up in red and a beep is heard in the headset. Fully charge the battery. Failure to do so may shorten the operating time.

# NAMES & FUNCTIONS

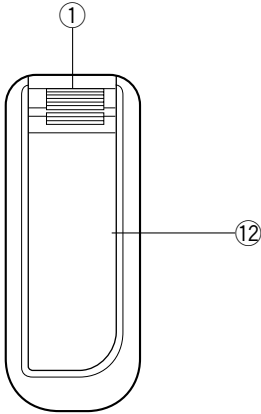
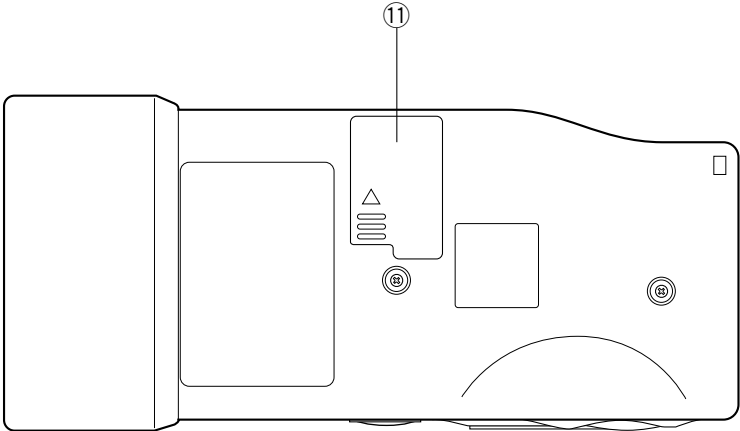
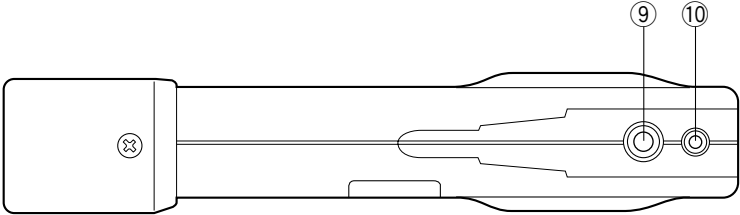
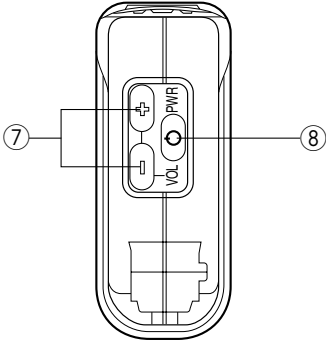
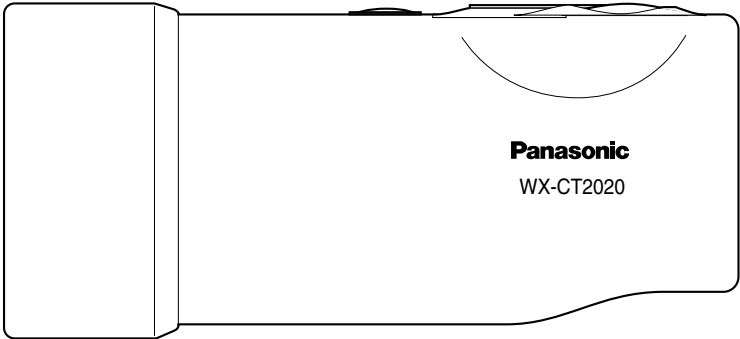
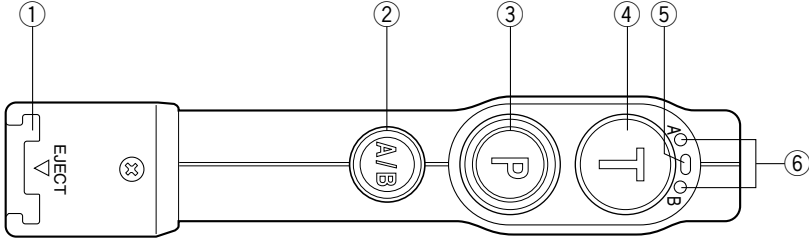

① **Battery Lock [EJECT]**

When removing the battery, slide out the lock.  
When loading a new battery, insert the battery until the lock clicks.

② **A/B Channel Selection Button [A/B]**

This button switches frequencies from Channel A to B and vice versa. The channel indicator ⑥ displays the selected channel in red (A) or green (B).

③ **Page Button [P]**

This button controls communications with store personnel.

While the button is held down in the Page PTT mode, you can speak to store personnel. When the button is pressed in the Page Lock mode, you can speak to the store personnel until you press a button a second time. When the button is released, you can hear the communication among store personnel.

④ **Talk Button [T]**

This button controls communications with the customer. While the button is held down in the Talk PTT mode, you can speak to the customer who is at the menu board. When the button is pressed in the Talk Lock mode, you can speak to the customer until you press the button a second time. When the button is released, you can hear the customer.

⑤ **Power Indicator**

The indicator shows the status as follows.

**Green ON:** Power is supplied, and the unit is operating.

**Red ON:** The battery requires recharging.

**Red Blink:** The channel selector (refer to p. 7) is set to a wrong position.

⑥ **Channel Indicator**

While lighting in red or green, this indicator shows which channel is in operation.

**Red lighting:** Channel A is selected.

**Green lighting:** Channel B is selected.

**Red blinking:** Channel A is being selected, and either the Talk or Page mode is activated.

**Green blinking:** Channel B is being selected, and either the Talk or Page mode is activated.

⑦ **Volume Control Buttons [VOL ▲ ▼]**

Pressing the respective buttons will increase or decrease the sound level.

⑧ **Power Button**

Pressing this button for one second will turn the order taker unit on or off.

⑨ **Earphone Input Jack**

This jack is used for connection with WX-C1027A Headset.

⑩ **Microphone Input Jack**

This jack is used for connection with WX-C1027A Headset.

⑪ **Switch Pocket**

Do not open the lid of this pocket. Should be opened only by qualified service personnel or system installers.

⑫ **Battery (Optional accessory)**

Refer to p. 3 PRECAUTIONS.

# BATTERY LOADING & REPLACEMENT

## Notes:

- Refer to the operating instructions included with the battery and battery charger.
- Prepare a fully charged battery.
- Battery replacement is recommended when the power indicator lights up in red and a constant beep is heard in the headset.

## ● Loading

Insert the battery as shown in the figure.

**Note:** Be sure to insert it until the lock clicks.

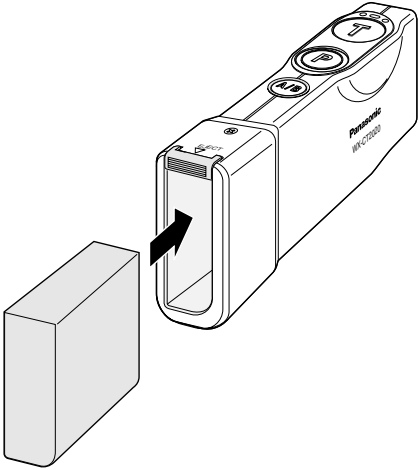

## ● Replacement

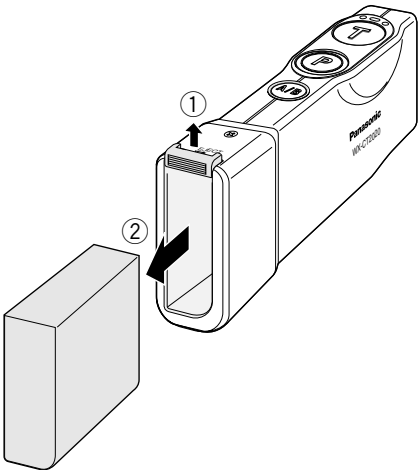

1. Slide the battery lock to the upside.
2. Remove the battery.

# SETUP PROCEDURES

**Caution:** Setup of this product should only be performed by qualified service personnel or system installers.

## ● Opening the Switch Pocket

1. Press the power button to turn off the order taker unit.
2. Open the switch pocket by moving the lid.
3. Set the channel selector and DIP switches. (Refer to p. 7 "Channel Group Selection", "DIP Switch Setup", and "Channel Interference Check".
4. After finishing the setup, close the switch pocket by moving the lid.
5. Turn on the order taker unit.

**Notes:** Be sure to turn off the order taker unit in Step 1. Otherwise, the channel group (refer to p. 7 "Channel Group Selection") will not be activated until you turn off and on the power again.

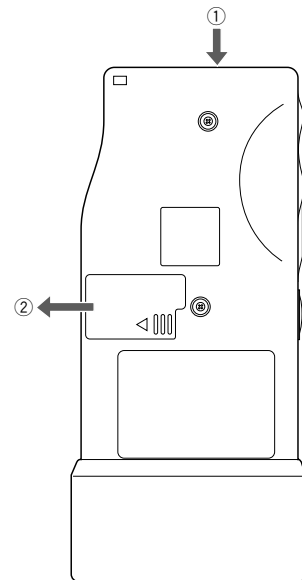

## ● Turning the Power On/Off

1. Press the power button to turn on the order taker unit.
2. After using the order taker unit, press the power button again to turn off the unit.

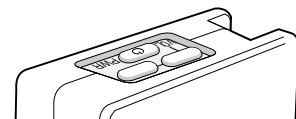

## ● Channel Group Selection

You can select a channel group by setting the channel selector, which is the rotary switch inside the switch pocket.

1. Press the power button to turn off the order taker unit.
2. Set the switch to the channel group.

**Available Channel Group:** 1 - 8

### Notes:

- When a switch position other than 1 through 8 is selected, the power indicator will blink in red.
- Be sure to turn off the order taker unit in Step 1. Otherwise, the channel group will not be activated until you turn off and on the power again.

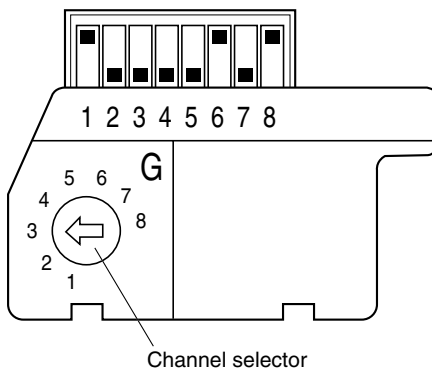

## ● DIP Switch Setup

An eight-bit DIP switch is provided for system setups. The initial settings are marked with an asterisk \*.

SW#	Function	ON	OFF
1	Location	USA*	Canada
2	DDT/SDT	Double Drive Thru	Single Drive Thru*
3	Manager Mode	ON	OFF(Normal)*
4	Role Assignment	Manager	Assistant*
5	Area Expansion	Expand	Normal*
6	Tone Squelch	ON*	OFF
7	Talk Lock Resumption	ON	OFF*
8	Compatibility	WX-C1010/WX-C1011	WX-CC2010*

1. Press the power button to turn off the order taker unit.
2. Set the switches as follows.

**SW#1:** For selection of a radio frequency suitable for the location

- ON:** Applies the US frequency to the headset.
- OFF:** Applies the Canadian frequency.

**SW#2:** Refer to the Operating Instructions included with the WX-CC2010.

**SW#3:** Refer to WX-CC2010 Operating Instructions.

**SW#4:** Refer to WX-CC2010 Operating Instructions.

**SW#5:** Refer to WX-CC2010 Operating Instructions.

**SW#6:** Enables or disables the tone squelch function.

- ON:** Outputs audio after detecting the tone squelch.
- OFF:** Outputs audio disregarding the tone squelch.

**Note:** Normally, set SW#6 to ON. Pay attention to a high level noise that may be output when set to OFF.

**SW#7:** While talking with a customer in the Talk Lock mode, you may need to contact store personnel in the Page PTT or Page Lock mode, which interrupts the Talk Lock mode. This switch specifies the status of the interrupted Talk Lock mode after ending the Page PTT or Page Lock mode.

- ON:** Resumes the Talk Lock mode.
- OFF:** Releases the Talk Lock mode.

**SW#8:** Specifies the system compatibility.

**ON:** Is compatible with the center modules WX-C1010 and WX-C1011.

**OFF:** Refer to WX-CC2010 Operating Instructions.

### Notes:

- Be sure to turn off the order taker unit in Step 1. Otherwise, the channel group (refer to "Channel Group Selection") will not be activated until you turn off and on the power again.
- SW#6 and SW#8 are used for channel interference check while turn on the headset.

## ● Channel Interference Check

SW#6 and SW#8 have the specific function of checking whether or not there is radio wave interference in the selected channel group.

1. Press the power button to turn off the order taker unit.

**<When WX-C1010 or WX-C1011 is used for the center module>**

2. Set the switches as follows, and turn on the headset. A noise will be heard in the headset.

- SW#6: OFF**
- SW#8: ON**

3. Listen to the sound while repeatedly pressing the [A/B] button.  
Only random noise will be heard if there is no interference. The presence of any sound other than noise indicates that there is interference.

**<When WX-CC2010 is used for the center module>**

2. Set the switches as follows, and turn on the headset.  
A noise will be heard in the headset.

**SW#6: OFF**

**SW#8: OFF**

3. Listen to the sound.  
(Refer to the operating instructions of the center module.)
4. Reselect the channel groups if there is any interference.

**Note:** Be sure to turn off the order taker unit in Step 1. Otherwise, the channel group (refer to p. 7 "Channel Group Selection") will not be activated until you turn off and on the power again.



## ● Operation Mode Setup

Three operation modes can be set up to adapt the order taker unit to your requirements. (Refer to the diagram for details.)

- Default channel and A/B Button Enable/Disable setup
- Talk lock/ Talk PTT
- Page lock/Page PTT

**Note:** The next page describes how to set up the order taker unit.

	Indicator			Selected Mode	Selection	Transition	Exit	
	Power	A/B channel						
		Red	Green					
Off	—	—	—	—	—			
Default Channel Setup				Selected Channel	A/B Button	While holding down (T) and (P) buttons, press POWER .	Press POWER .	
			● On	—	A			Disable
	↓	↓		—	A			Enable
	↓	↓	—	● On	B			Disable
	↓	↓		—	B	Enable		
Talk Setup	● On	● On	—	Talk Lock		(T)		
	↓	↓		Talk PTT				
Page Setup	● On	—		Page PTT		(P)		
	↓	↓	● On	Page Lock				

- PTT means "press to talk."
- The default settings are enclosed in bold lines on the table.

1. Press the power button to turn off the order taker unit.

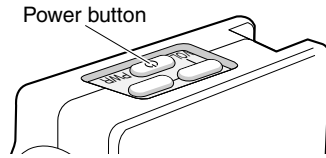

2. While holding down the buttons T and P simultaneously, press the power button to turn on the order taker unit. The order taker unit enters the setup mode where the indicators and buttons have different functions than in normal operation.

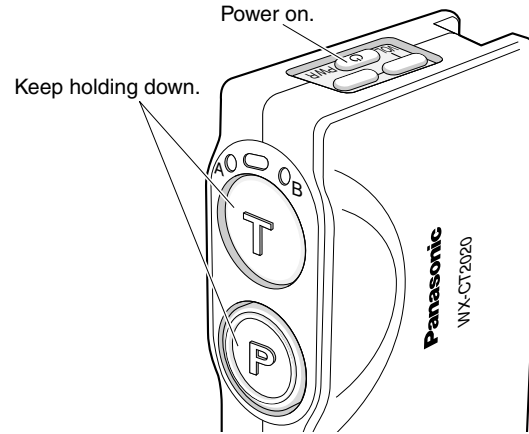

3. Select a default channel setup from four options, pressing the button T.

4. Press the button A/B to move to the talk setup and page setup.

5. Press the button T to select a talk mode.

6. Press the button P to select a page mode.

7. Press the button A/B to confirm that the indicators show the three modes selected for the default channel, talk and page.

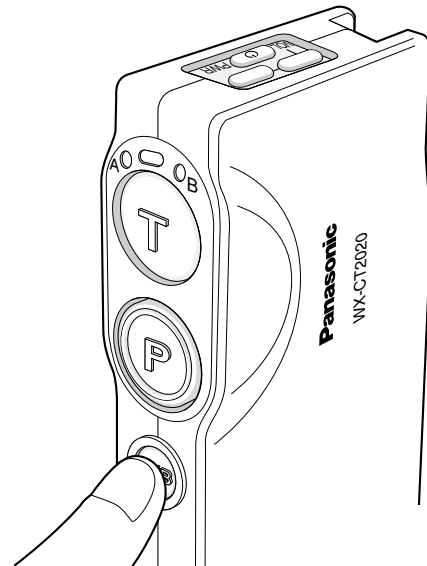

8. Press the power button to turn off the order taker unit, and then turn it on again. The newly selected operation mode will be applied to the order taker unit.

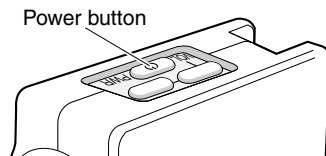

# OPERATING PROCEDURES

## ● Communications with Customers (TALK)

Any store personnel wearing the headset can communicate bidirectionally with any customer who is at the menu board.

1. Select a proper sound level by pressing the button + or -.



2. You will hear a tone in the headset when a vehicle arrives at the menu board.

**Note:** The tone duration varies depending on the settings made in the center module.

### <When the Talk PTT mode is preset>

1. Hold down the button T and speak to the customer. A short beep repeats in the headset.



2. Release the button and listen to the customer.



### <When the Talk Lock mode is preset>

1. Press the button T and speak to the customer. A short beep repeats in the headset.



2. Press the button again to release the lock and listen to the customer.



## ● Communications with Other Store Personnel (PAGE)

Store personnel wearing the headset can communicate with each other without being heard by customers.

### <When the Page Lock mode is preset>

1. Press the button P and speak into the microphone at a normal level.

A short beep repeats in the headset to notify all store personnel that the system operates in the page mode.



2. Press the button P again to release the lock and listen to the response from other store personnel.



### <When the Page PTT mode is preset>

1. Hold down the button P and speak into the microphone at a normal level.

A short beep repeats in the headset to notify all store personnel that the system operates in the page mode.



2. Release the button and listen to the response from other store personnel.



### Notes:

- Transmission using the talk button T or P is allowed for a single headset at a time. A continuous beep or distorted sound will be heard in a headset when a person wearing the headset presses the button T or P while another person is operating.
- Maintain a distance of more than 0.3 m {1 ft.} between the headset and the order taker, or more than 1 m {3 ft.} between the headset and the center module.
- Prior to operating the order taker unit, confirm that the system setup for the order taker unit, center module, and other devices has been completed.

# WHEN DISCONNECTING THE HEADSET PLUG

When disconnecting the headset plug from this product, pull the plug straight, holding the resin-molded part.

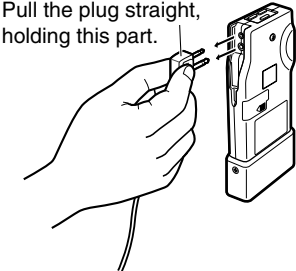

Do not hold the cable or pull the resin-molded part up and down. That may cause trouble.

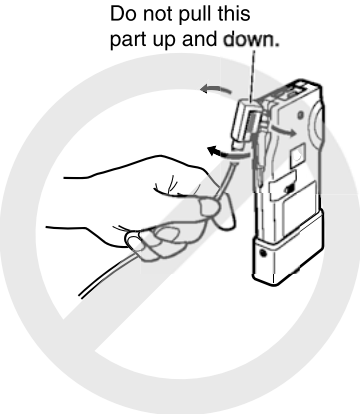
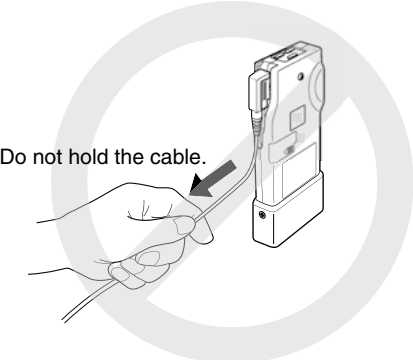

# TROUBLESHOOTING

Phenomenon	Possible Cause	What to do
The power indicator blinks in red.	A wrong channel is selected. (The channel selector is set to the wrong position. Refer to p. 7.)	Select any of channels 1 through 8. If no remedy exists, consult your dealer for repairs.
The power indicator lights up in red and a constant beep is heard in the headphone.	The battery power is nearing its end.	Recharge the battery.
Cannot turn on the order taker unit.	The battery is exhausted. The battery is not inserted correctly.	Recharge the battery. Position the battery properly. (Refer to p. 6.)
Cannot communicate with other store personnel or the customer at the menu board.	The center module may be turned off.	Turn on the power switch of the center module. (Refer to the operating instructions of the center module.) If no remedy exists, consult your dealer for repairs.
Cannot listen or talk to the customer, while communications with the store personnel are OK.	The vehicle detector may malfunction because the detector is not plugged into the center module, no power is supplied, or the detecting function is out of order.	Check that the vehicle detector is plugged in and is supplied power. (Refer to WX-CC2010 Installation Manual.) If no remedy exists, consult your dealer for repairs.
Cannot "page" or "talk" in certain areas.	Radio wave intensity is insufficient in the areas.	<ul style="list-style-type: none"> <li>• Remove any metal obstacles blocking radio waves, or try the following remedy.</li> <li>• <b>WX-C1010/WX-C1011:</b> Extend the transmission antennas.</li> <li>• <b>WX-CC2010:</b> Please add WX-CT2030 Transceiver.</li> </ul>

# SPECIFICATIONS

Operating Frequency:	UHF/FM
Type of Radio Wave:	F3E
Required Power Supply:	Rechargeable Ni-MH Battery, 3.6 V DC
Control Function:	Power (On/Off) Volume (Up/Down) Talk Page Channel Selection (A/B) Channel Group Selection (1-8) DIP Switch Setup (8 bit)
Dimensions:	139 mm (W) x 63 mm (H) x 26 mm (D) {5-1/2 in. (W) x 2-1/2 in. (H) x 1 in. (D)}
Weight (excluding battery):	110 g {0.24 lbs}

Dimensions and weights indicated are approximate.  
Specifications are subject to change without notice.

# STANDARD ACCESSORIES

Miniature Screwdriver ..... 1

# OPTIONAL ACCESSORIES

Battery (Ni-MH 3.6 V DC, 1100 mA/h)..... 2020BAT  
Battery Charger..... 2020CH  
Headset..... WX-C1027A





**Panasonic Digital Communications & Security Company**  
Unit of Matsushita Electric Corporation of America

**Information Systems Group**

**Zone Office**  
1707 N.Randall Road, Elgin, IL 60123 (866) 472-6767

**PANASONIC CANADA INC.**  
5770 Ambler Drive, Mississauga,  
Ontario, L4W 2T3 Canada (905)624-5010