

Panasonic®

Operating Instructions

Commercial Microwave Convection Oven

Model No. **NE-SCV2N**



Thank you for purchasing this Panasonic product.
Please read these instructions carefully before operating this oven and keep for future reference.
Before using this product, **please pay extra attention to “IMPORTANT SAFETY INSTRUCTIONS” (pages 4–8).**

For microwave oven safety reference, please visit the FDA’s web page at:
<http://www.fda.gov/Radiation-EmittingProducts/default.htm>

Contents

	Page
PRECAUTIONS TO AVOID POSSIBLE EXPOSURE TO EXCESSIVE MICROWAVE ENERGY	3
TV / RADIO / WIRELESS EQUIPMENT INTERFERENCE	3
IMPORTANT SAFETY INSTRUCTIONS	4
Instruction for Stacking	9
Types of Container to Use	11
Cooking Modes	12
Basic Usage	13
Cooking Chart	14
Accessories	16
Parts of your Oven	18
How to Operate the Touch Screen	20
Memory	20
Manual	21
Cooling	22
Tools	23
Preheating	28
Manual Cooking	29
Convection Cooking	29
Grill Cooking	30
Convection-and-Grill Cooking	31
Convection-and-Microwave Cooking	32
Grill-and-Microwave Cooking	33
Cooking in Steps	34
Memory Cooking	36
How to Save Memory	36
How to Delete Memory	38
How to Modify Memory	39
How to Set the Memory Number Figure	40
Cooking with a Saved Cooking Program	41
Care of your Oven	42
Regular Maintenance	46
Troubleshooting	47
Common Queries	48
When to Call a Service Agent	49
SD Memory Card	51
SD-USB Adapter	53
Specifications	54

Owner's Record

Model No. _____

Serial No. _____

The serial number of this product may be found on the side of the oven.

Date of Purchase _____

Dealer's Name _____

Dealer's Address _____

See page 49 before calling

Toll Free Service Information

To locate a convenient service agent call

1-877-266-6836

Chef Support: 201-348-7305

www.panasonic.com/cmo

Virtual Test Kitchens

PRECAUTIONS TO AVOID POSSIBLE EXPOSURE TO EXCESSIVE MICROWAVE ENERGY

- | | |
|---|--|
| <p>(a) Do not attempt to operate this oven with the door open since open-door operation can result in harmful exposure to microwave energy. It is important not to defeat or tamper with the safety interlocks. Under normal conditions, the oven will not operate with the door open.</p> <p>(b) Do not place any object between the oven front face and the door, or allow soil or cleaner residue to accumulate on sealing surfaces.</p> | <p>(c) Do not operate the oven if it is damaged. It is particularly important that the oven door is closed properly and that there is no damage to the :</p> <p>(1) door (bent)</p> <p>(2) hinges and latches (broken or loosened)</p> <p>(3) door seals and sealing surfaces.</p> <p>(d) The oven should not be adjusted or repaired by anyone except properly qualified service personnel.</p> |
|---|--|

TV / RADIO / WIRELESS EQUIPMENT INTERFERENCE

This product has been tested and found to comply with the limits for Microwave Oven, pursuant to Part 18 of the FCC Rules. This product can radiate radio frequency energy, which could cause interference to such products as radio, TV, baby monitor, cordless phone, Bluetooth, wireless router, etc., which can be confirmed by turning this product off and on. If present, the user is encouraged to try to correct by taking one or more of the following countermeasures:

- (1) Increase the spacing distance between the microwave oven and other product receiving the interference.
- (2) If possible, use a properly installed receiver antenna and/or reorient the receiving antenna of the other product receiving the interference.
- (3) Plug the microwave oven into a different outlet from the other product receiving the interference.
- (4) Clean door and sealing surfaces of the oven. (See Care of your Oven)

IMPORTANT SAFETY INSTRUCTIONS



Your safety and the safety of others are very important.

We have provided important safety messages in this manual and on your appliance. Always read and obey all safety messages.

This is the safety alert symbol. It is used to alert you to potential hazards that can kill or hurt you and others.

All safety messages will follow the safety alert symbol and either the word "DANGER", "WARNING" or "CAUTION". These words mean:

DANGER

You can be killed or seriously injured if you don't immediately follow instructions.

WARNING

You can be killed or seriously injured if you don't follow instructions.

CAUTION

You can be exposed to a potentially hazardous situation which, if not avoided, may result in minor or moderate injury.

All safety messages will tell you what the potential hazard is, tell you how to reduce the chance of injury, and tell you what can happen if the instructions are not followed.

Your microwave oven is a cooking device and you should use as much care as you use with a stove or any other cooking device.

When using this electric appliance, basic safety precautions should be followed, including the following:

 **WARNING** – To reduce the risk of burns, electric shock, fire, injury to persons or exposure to excessive microwave energy:

1. Read all instructions before using the appliance.
2. Read and follow "**PRECAUTIONS TO AVOID POSSIBLE EXPOSURE TO EXCESSIVE MICROWAVE ENERGY,**" found on page 3.
3. This appliance must be grounded. Connect only to a properly grounded outlet. See "**GROUNDING INSTRUCTIONS**" found on page 7.
4. Install or locate this appliance only in accordance with the provided installation instructions found on page 7.
5. Do not cover, or block any openings on this appliance.
6. Do not store, or use this appliance outdoors. Do not use this product near water for example, near a kitchen sink, in a wet basement, or near a swimming pool, and the like.
7. Use this appliance only for its intended use as described in this manual. Do not use corrosive chemicals or vapors in this appliance. This type of oven is specifically designed to heat, or cook food. It is not designed for industrial or laboratory use.
8. When cleaning surfaces of door and oven that come together on closing the door, use only mild, non-abrasive soaps or detergents applied with a sponge or soft cloth.
9. This appliance is not to be used by children or persons with reduced physical, sensory, or mental capabilities, or lack of experience and knowledge, unless they have been given supervision or instruction.
10. DO NOT operate this appliance if it has a damaged cord or plug, is not working properly, or has been damaged or dropped.
11. Do not immerse cord or plug in water.
12. Keep cord away from heated surfaces.
13. Do not let cord hang over edge of table or counter.
14. **SUITABLE FOR SERVICING ONLY WHEN DE-ENERGIZED.** This appliance should be serviced only by qualified service personnel. Contact the nearest authorized service facility for examination, repair or adjustment.

15. Some products such as whole eggs and sealed containers (for example, closed glass jars) may explode and should not be heated in this oven.
16. To reduce the risk of fire in the oven cavity:
 - (a) Do not overcook food. Carefully attend appliance if paper, plastic, or other combustible materials are placed inside the oven to facilitate cooking.
 - (b) Remove wire twist-ties from paper or plastic bags before placing bag in oven.
 - (c) If materials inside the oven should ignite, keep oven door closed, turn oven off, and disconnect the power cord, or shut off power at the fuse or circuit breaker panel.
 - (d) Do not use the cavity for storage purposes.
Do not leave paper products, cooking utensils, or food in the cavity when not in use.
17. Liquids, such as water, coffee, or tea are able to be overheated beyond the boiling point without appearing to be boiling due to surface tension of the liquid. Visible bubbling or boiling when the container is removed from the microwave oven is not always present. **THIS COULD RESULT IN VERY HOT LIQUIDS SUDDENLY BOILING OVER WHEN A SPOON OR OTHER UTENSIL IS INSERTED INTO THE LIQUID.** To reduce the risk of injury to persons:
 - (a) Do not overheat the liquid.
 - (b) Stir the liquid both before and halfway through heating it.
 - (c) Do not use straight-sided containers with narrow necks.
 - (d) After heating, allow the container to stand in the microwave oven for a short time before removing the container.
 - (e) Use extreme care when inserting a spoon or other utensil into the container.
18. Repairs should only be done by a qualified service person.
19. In order to maintain the high quality of the magnetron tubes and other components, you are requested not to turn the oven on with no food inside.
20. Do not dry clothes in the oven since there is a possibility of the clothes burning if left in the oven for too long of a time.
21. The oven is intended for heating food and beverages. Drying of food or clothing and heating of warming pads, slippers, sponges, damp cloth and similar may lead to risk of injury, ignition or fire.
22. Do NOT use newspapers or paper bags for cooking.
23. Do NOT hit or strike the control panel. Damage to controls may occur.
24. Accessible parts may become hot during use.
25. Take caution when removing the hot accessories after cooking. It may cause burn. Use oven gloves.
26. Do not store flammable materials next to, on top of, or in the oven. It could be a fire hazard.
27. The contents of feeding bottles and baby food jars must be stirred or shaken and the temperature checked before consumption, in order to avoid burns.
28. Microwave heating of beverages can result in delayed eruptive boiling, therefore care must be taken when handling the container.
29. Floor at adjacent to the oven may be slippery, care should be taken.
30. Do not overturn or drop this oven or accessories. Doing so may cause injury, electric shock, or microwave leakage.
31. Do not attempt to deep fat fry in your oven.
32. The oven should not be cleaned with a water jet.
33. The oven should not be cleaned with a steam cleaner.
34. Electromagnetic fields can present a possible danger. We would recommend that people using a heart pacemaker avoid proximity to these fields.
35. When the oven is not in use, it is recommended that items are removed.
If left inside and the switch is accidentally activated, there is potential for damage to occur.
36. Do not heat with oil from the leftover food or the food left in the accessories in the oven cavity. Doing so may generate sparks and cause fire or smoking.

IMPORTANT SAFETY INSTRUCTIONS

37. It is recommended to use personal protection equipment in case of spreading hot food stuff.
38. Exterior oven surfaces, including air vents on the cabinet and the oven door will get hot during use. Take care when opening or closing door and when inserting or removing food and accessories.
There are heaters situated in the top and back of the oven.
After use, the roof, walls and floor will be very hot.
39. Take caution when rapidly cooling the hot accessories after cooking. It may cause burn with steam or airborne droplets. It may also cause injury by the accessories breaking.
40. It is essential reheated food is served "piping hot". Always check before serving and if in doubt return food to oven for further heating.
All temperatures provided are for guidance only. Local legislation of food temperature requirements should be applied, to ensure a safe temperature has been reached before serving any food.
41. The standing time is essential for foods cooked or reheated by CONVECTION-AND-MICROWAVE, or GRILL-AND-MICROWAVE. During the standing time, heat will continue to conduct to the center to cook the food completely.
The denser the food, the longer the standing time. Reheated foods also require a standing time.
42. When the oven has finished operating, the fan motor will continue to rotate in order to cool the electric components. This is normal, and food can still be removed from the oven during this cooling period. Do not remove the plug or turn off the breaker.

Certification

cULus, NSF, FCC, CISPR 11 and 14-1, and EPA202(UL/KNLZ listed for ventless operation.)

IF BOTTOM PLATE BREAKS or CRACKS, or THERE IS SPARKING IN THE CAVITY WHILE HEATING FOOD, DO NOT CONTINUE TO USE OVEN AND CONTACT AUTHORIZED SERVICE AGENCY IMMEDIATELY!! 1-877-266-6836

SUITABLE FOR SERVICING ONLY WHEN DE-ENERGIZED.

During service and/or replacement of parts, the oven should be disconnected from the power supply. Once the plug is removed, it should remain visible to the service operator to avoid inadvertent reconnection.

Panasonic Corporation makes no warranties of any kind, either express or implied, including but not limited to warranties of merchantability, fitness for a particular purpose, of title, or of non-infringement of third party rights. Use of the product by a user is at the user's risk. All cooking settings are for guidance only and should be altered depending on the initial state, temperature, moisture and type of food. Depending on the characteristics of the food, cooking times and power levels may need to be adjusted. Prior to service of food ensure it has reached a safe temperature.

INSTALLATION

EXAMINE YOUR OVEN

Unpack the oven, remove all packing material, and examine the oven for any damage such as dents, broken door latches or cracks in the door. Notify the service agent immediately if the unit is damaged. DO NOT install it if the unit is damaged.

GROUNDING

When an outlet is not grounded, it is the personal responsibility and obligation of the customer to have it replaced with a properly grounded outlet.

VOLTAGE AND POWER WARNING

The voltage used must be the same as specified on the oven. Using another voltage than that which is specified is dangerous and may result in a fire or other type of accident causing damage. Do not plug your oven in via an extension cable as this can be dangerous. The back of the oven heats up during use. Do not allow the cord to be in contact with the back of the oven or cabinet surface.

PLACEMENT OF THE OVEN

Locate the oven on a smooth, flat, and stable surface.

There should be no gap between the table surface and the bottom of the oven. Do not place the oven in a hot or damp area, e.g. near a stove, sink, or directly above heat lamps on a serving line. Free airflow around the oven is important. There is a possibility of a small amount of interference with weak broadcast signals if the microwave oven is too close to a radio or TV.

GROUNDING INSTRUCTIONS

This appliance must be grounded. In the event of an electrical short circuit, grounding reduces the risk of electric shock by providing an escape wire for the electric current. This appliance is equipped with a cord acting as a grounding wire with a grounding plug. The plug must be plugged into an outlet that is properly installed and grounded.

WARNING – Improper use of the grounding plug can result in a risk of electric shock.

Consult a qualified electrician or serviceman if the grounding instructions are not completely understood, or if doubt exists as to whether the appliance is properly grounded. If it is necessary to use an extension cord, use only a 3-wire extension cord that has a 3-blade grounding plug, and a 3-slot receptacle that will accept the plug on the appliance. The marked rating of the extension cord shall be equal to or greater than the electrical rating of the appliance.

WIRING REQUIREMENTS

No other appliance should share the circuit with the microwave convection oven. If it does, the branch circuit fuse may overload and either cause the oven to produce lower power output or blow the fuse.

1. This oven must be on a separate, 60 Hz GROUNDED CIRCUIT – minimum 20 amps.
2. The microwave ovens are built to operate on 2 different voltages (240 V or 208 V).

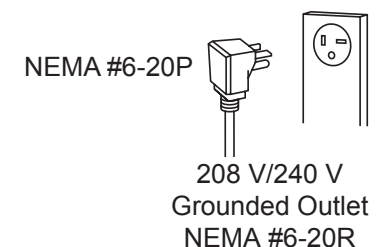

 An external equipotential bonding conductor is provided at the back side of the oven and it is marked by this symbol.

IMPORTANT SAFETY INSTRUCTIONS

PLEASE READ THE FOLLOWING CAUTIONS BEFORE USING THIS MICROWAVE OVEN

Failure to follow these instructions and properly maintain this unit may lead to premature failure of the microwave and may void the warranty.

- The oven is free standing type and shall not be placed in a cabinet. Do not place the oven in a hot or damp place; e.g. near a gas or electric range. Do not operate the oven when the room temperature is higher than 104°F (40°C) and/or the humidity is more than 85 %.
- For safe and efficient operation, the oven must have sufficient air flow to the air vents i.e. at least 4" (10 cm) at both sides, 1.2" (3 cm) at the rear and 8" (20 cm) at the top. The front side must not be blocked. Do not install the oven at 60" (150 cm) or more above the floor. Doing so may result in danger of burns. Only a combination of same models are allowed when stacking. Oven must be placed for easy access to control panel and door, as well as to disconnect power or shut off power by fuse or circuit breaker.

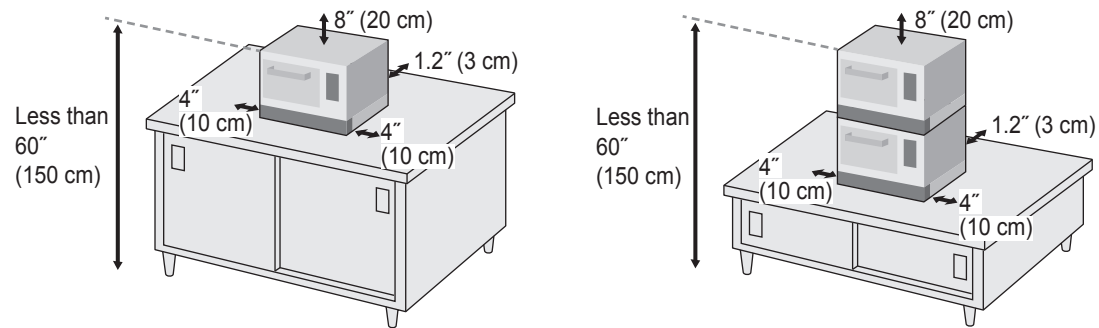

- Do not slam door shut or pull down on the door as this may damage the door latch mechanism and/or hinges and render the microwave inoperative.
- Before use, the user should check that utensils are suitable for use in the oven. See page 11.
- Do not use metalware, ceramics trimmed with gold or silver, or any container with a metal content when cooking with the microwave. ONLY THE PROVIDED WIRE RACK CAN BE USED.
- The height of the divider must be greater than the height of the oven (17.0" or 430 mm).
For stacking,
The height of the divider must be greater than the height of the ovens (33" or 840 mm)

Ventilation

The NE-SCV2N has been approved by Underwriter's Laboratory for ventless operation (UL KNLZ listing) for all food items except for foods classified as "fatty raw proteins." Such foods include bone-in, skin-on chicken, raw ham-burger meat, raw bacon, raw sausage, steaks, etc. If cooking these types of foods, consult local HVAC codes and authorities to ensure compliance with ventilation requirements.

To ensure continued compliance with all health, building, and fire codes, you are required to maintain clean and sanitary conditions around your oven at all times.

Instruction for Stacking

Oven can be stacked up to two ovens by fixing with the Panasonic joint plate (Foot Bracket/A11343G80BP). The joint plate is an optional item. Contact the dealer or a service agent. (p.3) Request the installation to an electric constructor. (The construction cost is not included in the price of the oven.)

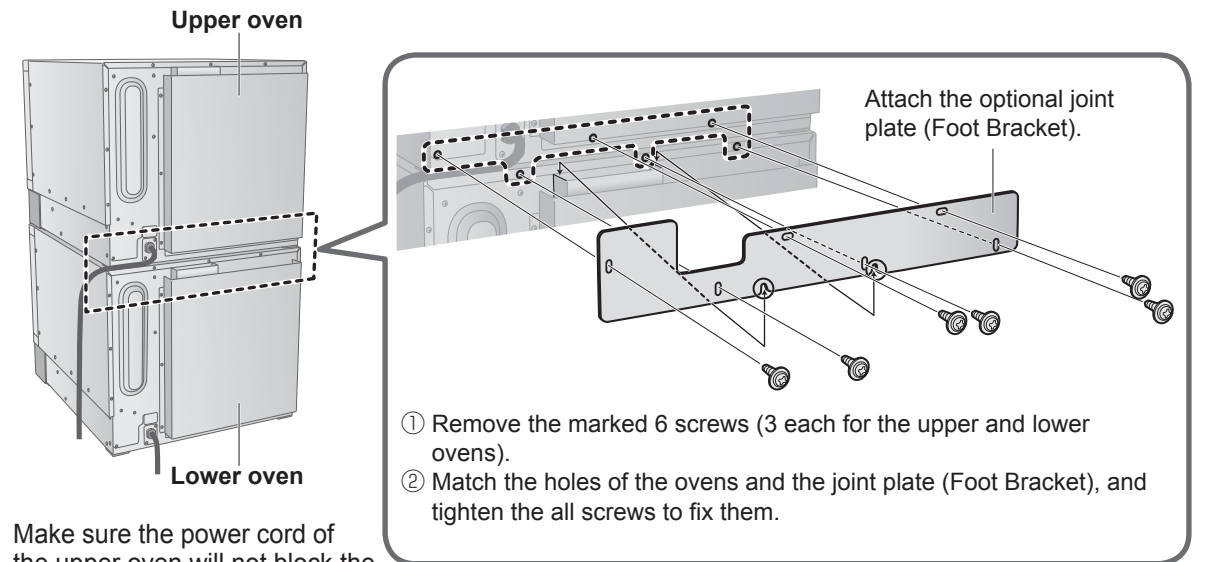

Make sure the power cord of the upper oven will not block the exhaust vent of the lower one.

- Please follow distance guidelines below.

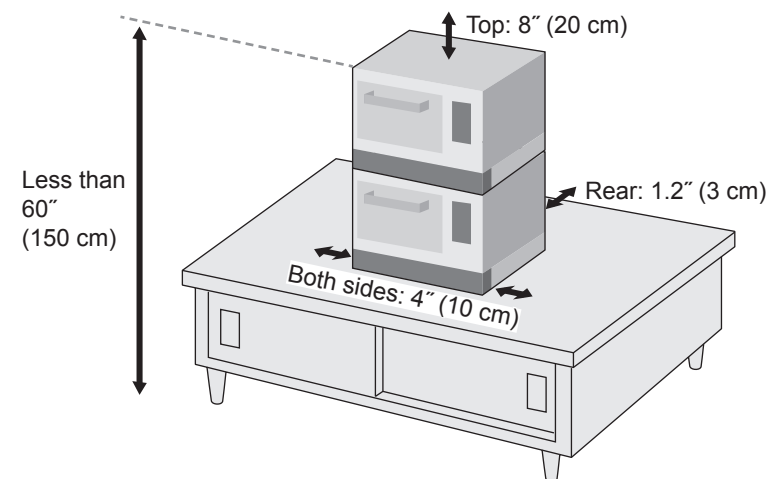

⚠ WARNING

Do not install the oven at 60" (150 cm) or more above the floor. Doing so may result in danger of burns. Only a combination of same models are allowed when stacking.

⚠ CAUTION

Disconnect the power cord from the wall outlet before installation and be sure the oven cavity is empty. It may cause electric shock or injury.

Instruction for Stacking

Installation on the kitchen counter

For single installation

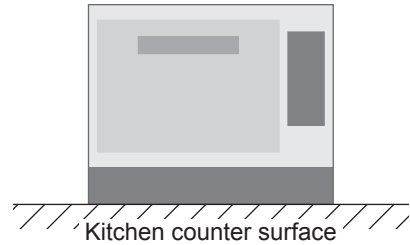

You can put the oven on the kitchen counter.

To clean underneath the oven, please see page 42.

For stacking

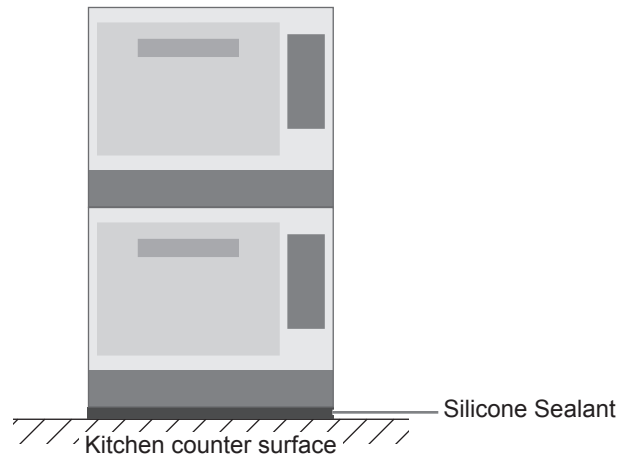

When oven is stacked, its base must be sealed in accordance with NSF Standards as per the following instructions.

1. Oven should be located on a level counter top surface. Complete the electrical connections.
2. Thoroughly clean and sanitize the oven bottom perimeter and the counter top area around the oven perimeter.
3. Remove the Air Filter from the front of the oven before applying high temp. silicone.
4. Lay generous bead of high temp. silicone seal around the entire perimeter of the base of each oven unit.
5. Smooth the silicone seal into the crevice with finger or tool to provide a cover seal.

USING YOUR OVEN

Do not store any objects inside the oven in case it is accidentally turned on. In case of electronic failure, the oven can be turned off at wall outlet.

WHEN THE HEATER IS TURNED ON FOR THE FIRST TIME

You may detect smoke or a harsh odor. This is normal and is caused by the burning off of the oil that is used to protect the oven cavity.

You may prefer to perform a blank baking as described below if you find this unpleasant;

1. Place the supplied Base Plate Liner, Ceramic Tray, and Wire Rack into the oven. (p.17)
2. Select **Manual** and preheat the oven at 525°F (280°C) for 20 minutes. (p.28)
3. Once this operation is completed, open then close the door and press the Stop/Reset pad to return to the initial screen.

● Always ventilate when performing a blank baking.

● There is no food sanitation issues even if you use the oven without performing a blank baking first.

Types of Container to Use

CONVECTION-AND-MICROWAVE/ GRILL-AND-MICROWAVE

As these programs use microwaves and heat (CONVECTION or GRILL), you must choose the container carefully.

DO USE: Ceramics, Heat Resistant glass e.g. Pyrex®

● As for metal, ONLY THE PROVIDED WIRE RACK CAN BE USED.

DO NOT USE:

Plastics, Cling film, Metal, Metal skewers, Aluminum foils, Silicon, Lacquerware, Glass without heat resistance, Paper, Wood, Wicker

CONVECTION/GRILL/CONVECTION-AND-GRILL

DO USE: Ceramics, Heat Resistant glass e.g. Pyrex®, Metal, Metal skewers, Aluminum foil

DO NOT USE:

Plastics, Cling film, Silicon, Lacquerware, Glass without heat resistance, Paper, Wood, Wicker

MICROWAVE

● You can use microwave only cooking at Step 2 and Step 3 in Cooking in Steps. (pp.34–35)

DO USE: Ceramics, Heat Resistant glass e.g. Pyrex®, Plastics/Cling film/Silicon with heat resistance of 350°F (180°C) or higher

● As for metal, ONLY THE PROVIDED WIRE RACK CAN BE USED.

● You can not use any dish with METAL PATTERN or TRIM.

DO NOT USE:

Metal, Metal skewers, Aluminum foil, Plastics with heat resistance less than 350°F (180°C), Polyethylene, Melamine, Phenol, Urea resin, Lacquerware, Glass without heat resistance, Paper, Wood, Wicker

● Please observe the heatproof temperature described in the package when using heat-resistant cooking sheet or parchment paper, etc.

Cooking Modes

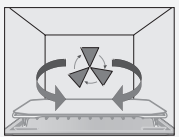
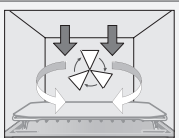
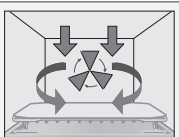
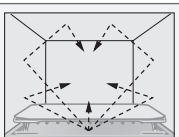
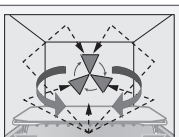
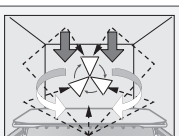
How to Cooking	Cooking Modes
Convection  Heater	A convection heater (circulation fan heater) circulates heat throughout the oven cavity and cooks food fully while controlling the set temperature. (p.29)
Grill  Heater	A grill heater provides heat and a circulation fan operates to distribute the heat throughout the oven cavity. Every surface of the food is well-cooked. (p.30)
Convection-and-Grill  Heater	Both convection heater (circulation fan heater) and grill heater circulate heat in the oven cavity while controlling the temperature. Cooks the food throughout while browning on the surface. (p.31)
Microwave  Microwave	<ul style="list-style-type: none"> You can use microwave only cooking at Step 2 and Step 3 in Cooking in Steps. (pp.34–35) Applies microwaves to the food causing the molecules in the food to strongly collide and give rise to heating by friction. As a result, the food is heated about the same on the surface and inside.
Convection-and-Microwave  Heater+Microwave	Combined cooking with convection heater (circulation fan heater) and microwave. A convection heater circulates heat throughout the oven cavity with controlling the set temperature while the microwave heats the food fully. The cooking time is reduced. (p.32)
Grill-and-Microwave  Heater+Microwave	Combined cooking with grill heater and microwave. A grill heater adds heat while a microwave heats the food, and additionally a circulation fan operates to give the entire surface a crisp finish. The cooking time is reduced. (p.33)

● Illustrations are images. The accessories to be used differ depending on the cooking mode.

About the arrows in the illustration

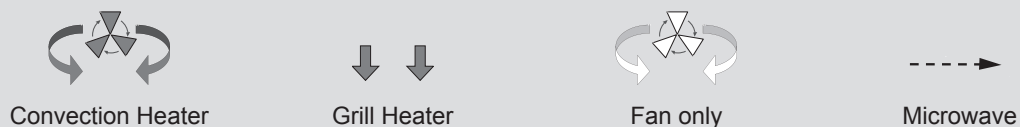

Basic Usage

You can cook in a cooking mode suitable for the application.

Select **Memory** or **Manual**

	Convection	Convection-and-Grill	Grill-and-Microwave
Step 1 only cooking	(p.29) Heater	(p.31) Heater	(p.33) Heater+Microwave
	(p.30) Heater	(p.32) Heater+Microwave	

● Microwave only cooking is not possible in Step 1.

● Illustrations are images. The accessories to be used differ depending on the cooking mode.

Fan Speed

- The fan circulates the heat of the heater throughout the entire oven to brown food and give a crisp finish to the surface.
- The fan speed can be set from 30 % to 100 % when cooking other than the microwave. Adjust it depending on the food.

■ Fan speed guide

30 %	40 %	50 %	60 %	70 %	80 %	90 %	100 %
------	------	------	------	------	------	------	-------

← Bake gently →

← Gives the surface a crispy finish →

→ Dries the food quickly and makes the surface crispy →

6 types* of cooking modes can be combined up to 3 continuous steps. *Step 1: 5 types

Step	Example
Step 1	e.g.: Convection 525°F (280°C), Fan speed 100 %, Microwave P5, 1 min
Step 2	e.g.: Microwave P4, 50 sec
Step 3	e.g.: Grill High, Fan speed 30 %, 30 sec

■ Maximum power and cooking time for Convection-and-Microwave/Grill-and-Microwave cooking (p.34)

Saving a cooking program to the memory

Up to 1000 programs of cooking programs can be saved to the memory. [You can also set 10 programs, and default setting is 100 programs. (p.40)]
The saved cooking program can be used to achieve the same cooking. (p.41)

Cooking Chart

Cooking time is just a guide. Adjust depending on the kind of food and the start temperature.

- This oven is designed for reheating already cooked foods.
- Panasonic Corporation makes no warranties of any kind, either express or implied, including but not limited to warranties of merchantability, fitness for a particular purpose, of title, or of non-infringement of third party rights. Use of the product by a user is at the user's risk. All cooking settings are for guidance only and should be altered depending on the initial state, temperature, moisture and type of food. Depending on the characteristics of the food, cooking times and power levels may need to be adjusted. Prior to service of food ensure it has reached a safe temperature. Oil from the food may cause failure.
- Please set the provided Base Plate Liner, Ceramic Tray, Wire Rack and additionally other accessories suitable for the intended cooking mode in the oven before starting preheating, except Oven Sheet and Aluminum Paddle.
- If the fan speed is high, foods on the surface may be scattered. In this case, please lower the fan speed.
- Refer to "Accessories" (p.16) for details on how to use the accessories before cooking.

■ Reheat

Base Plate Liner, Ceramic Tray, and Wire Rack are used on all menus.

Menu	Start Temp.	Quantity (Weight)	Accessory	Preheat Temp.	Program						
					Step	Conv	Fan	Grill	MW	Time	Total Time
Toasted bagel	Room temp.	1 whole (3.5 oz) cut in 2 pieces	Ceramic Plate	525°F (280°C)	1	525°F (280°C)	100 %	OFF	P6	40 sec	40 sec
Croissant	Room temp.	1 piece (2 oz)	Oven Sheet/ Ceramic Plate	525°F (280°C)	1	525°F (280°C)	80 %	OFF	P6	23 sec	23 sec
Chocolate Croissant	Room temp.	1 piece (2.3 oz)	Oven Sheet/ Ceramic Plate	525°F (280°C)	1	525°F (280°C)	80 %	OFF	P6	23 sec	23 sec
Muffin	Room temp.	1 piece (3.5 oz)	Oven Sheet/ Ceramic Plate	525°F (280°C)	1	525°F (280°C)	80 %	OFF	P6	25 sec	25 sec
Grilled Cheese Sandwich	Chilled	1 piece (3.6 oz)	Oven Sheet/ Ceramic Plate	525°F (280°C)	1	525°F (280°C)	80 %	OFF	P8	50 sec	50 sec
Hero Sandwich	Chilled	1 piece (7 oz)	Oven Sheet/ Ceramic Plate	525°F (280°C)	1	525°F (280°C)	100 %	OFF	P8	40 sec	40 sec
Breakfast Sandwich	Chilled	1 piece (4.6 oz)	Oven Sheet/ Ceramic Plate	525°F (280°C)	1	OFF	90 %	LOW	P8	1 min 10 sec	1 min 10 sec
Chicken Wrap	Chilled	1 piece (8 oz)	Oven Sheet/ Ceramic Plate	525°F (280°C)	1	OFF	60 %	LOW	P8	1 min	1 min
9" Pepperoni Pizza	Frozen	1 piece (13.4 oz)	Pizza Plate	525°F (280°C)	1	525°F (280°C)	30 %	OFF	P8	1 min 30 sec	3 min
					2	525°F (280°C)	30 %	OFF	-	1 min 30 sec	
Chicken tenders (precooked)	Frozen	3-5 units (5 oz)	Oven Sheet/ Ceramic Plate	525°F (280°C)	1	525°F (280°C)	50 %	OFF	P8	2 min 20 sec	2 min 20 sec
French fries (precooked)	Frozen	4 oz	Oven Sheet/ Ceramic Plate	525°F (280°C)	1	525°F (280°C)	100 %	OFF	P6	1 min 30 sec	1 min 30 sec
Mozzarella sticks	Frozen	4 units (2.7 oz)	Oven Sheet/ Ceramic Plate	525°F (280°C)	1	525°F (280°C)	90 %	OFF	P6	40 sec	40 sec
Fish sticks (precooked)	Frozen	3-5 units (5 oz)	Oven Sheet/ Ceramic Plate	525°F (280°C)	1	525°F (280°C)	60 %	OFF	P6	1 min 40 sec	1 min 40 sec

Menu	Start Temp.	Quantity (Weight)	Accessory	Preheat Temp.	Program						
					Step	Conv	Fan	Grill	MW	Time	Total Time
Onion Rings	Frozen	3.5 oz	Oven Sheet/ Ceramic Plate	525°F (280°C)	1	525°F (280°C)	50 %	OFF	P8	45 sec	45 sec
Macaroni Cheese	Chilled	1 piece (6 oz)	Ceramic Plate	525°F (280°C)	1	525°F (280°C)	60 %	OFF	P6	2 min	3 min 20 sec
					2	OFF	40 %	LOW	P4	40 sec	
					3	525°F (280°C)	100 %	HIGH	OFF	40 sec	
Hash Browns	Frozen	4 units (8.9 oz)	Oven Sheet/ Ceramic Plate	525°F (280°C)	1	OFF	100 %	LOW	P8	1 min 30 sec	2 min 10 sec
					2*	525°F (280°C)	100 %	HIGH	OFF	10 sec	
					3	525°F (280°C)	100 %	HIGH	OFF	30 sec	
Quiche	Frozen	1 unit (6.17 oz)	Oven Sheet/ Ceramic Plate	525°F (280°C)	1	525°F (280°C)	50 %	OFF	P8	2 min 15 sec	2 min 15 sec

*After completing step 2, when the beep sounds please turn over the Hash Browns.

● Microwave Power Level

Display	Power	Display	Power
P8	1200 W	P3	500 W
P7	1050 W	P2	300 W
P6	900 W	P1	200 W*
P5	750 W	P0	0 W
P4	600 W		

*equivalent to 200 W

⚠ WARNING

Do not over-heat food.

If the heating time is too long for the amount of food, there is a danger of fire or smoke.

- When heating, always start with minimum cooking time and heat while keeping an eye on the progress.
- In particular, take care when heating small amounts, oily or fatty foods or liquids, or sweet potatoes and other root vegetables.

Accessories

● To purchase accessories, please contact the dealer or a service agent. (p.3)
Take care when handling Ceramic Tray, Pizza Plate, and Ceramic Plate as they are breakable. If they are damaged, stop using them and contact the dealer or a service agent.

Base Plate Liner **Ceramic Tray** **Wire Rack** **Aluminum Paddle**

Pizza Plate (black) **Ceramic Plate (white)** **Oven Sheet** **Specified SD Memory Card** **SD-USB Adapter**

● Set in the main unit when shipped from the factory. (p.51)

● Use the SD-USB Adapter to use SD Memory Cards. (p.53)

Always install Base Plate Liner, Ceramic Tray and Wire Rack before use.

■ Procedure to attach the Base Plate Liner

Use the Base Plate Liner to prevent the food and oil stains on the bottom surface of the oven cavity .

- ① **After removing the Base Plate Liner from the packaging, turn it over and bend it along the left and right bend lines.**

(Bend the Base Plate Liner in the opposite direction to the orientation when removed from the packaging.)

Orientation when removed from the packaging

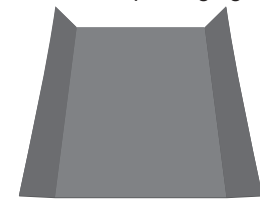

Turn over and bend on the left and right

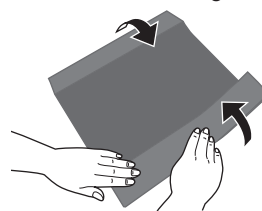

- ② **Remove all the accessories from the oven, insert the bent Base Plate Liner up to the inside of the oven cabinet, and ensure that it is in close contact with the inside of the oven cabinet.**

(Ensure close contact so that there is no gap between the inner side of the oven and the Base Plate Liner. If there is a gap, oil, etc. will collect there.)

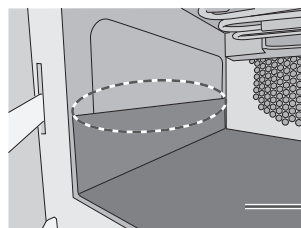

Base Plate Liner

- ③ **Place the Ceramic Tray, Wire Rack, and accessories required for cooking on the Base Plate Liner in that order.**

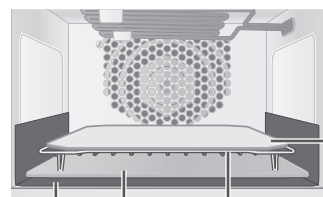

Ceramic Plate, Oven Sheet, Pizza Plate etc.
Wire Rack
Ceramic Tray
Base Plate Liner

● Illustrations may differ to the actual items.

⚠ CAUTION

The oven shall not be operated by microwave without food in the oven.

Doing so may cause the oven to become abnormally hot due to sparks and the red-hot inner bottom surface. This may cause a risk of burns.

- Also, do not operate the oven only with containers, and the provided accessories.
- Take care not to burn yourself when removing any accessories from the oven after cooking. Use oven gloves.

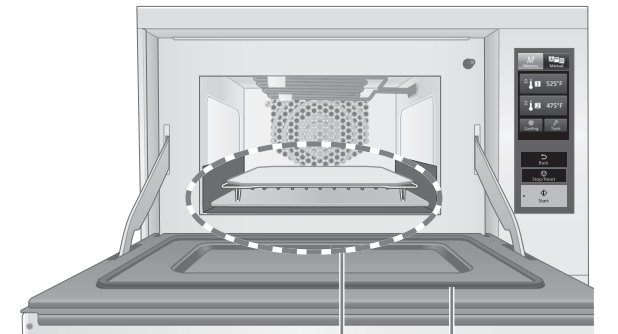

There is a seam in the door seal - this is not damage.

Use to prevent the oven from getting dirty or to remove multiple items at once.
E.g. Hash browns or sandwich

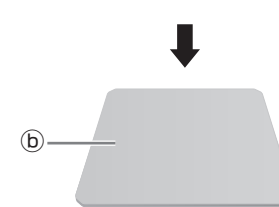
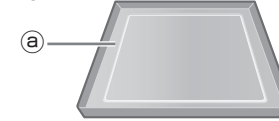

For baking the bottom of a food
E.g. Pizza

or
(Select either depending on the food.)

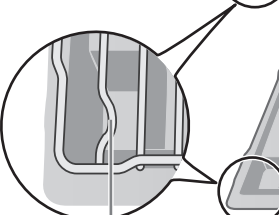
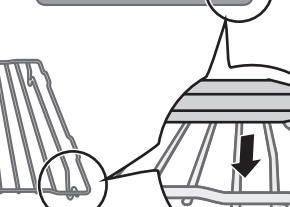
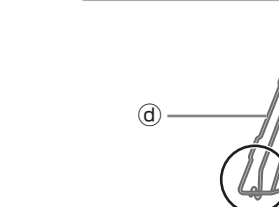

Place the rack so that it is within the tabs of the Ceramic Tray.

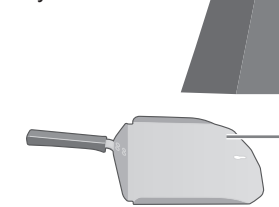

Aluminum Paddle

- Use Aluminum Paddle to take out Oven Sheet or food directly. Do not use for removing the other accessories.
- Do not place in contact with acidic or alkaline food for long periods of time.

- Oven Sheet**
Place on the Ceramic Plate only. Do not place on the Pizza Plate. Place food on the Oven Sheet.
● It is recommended to replace it every 3 to 6 months depending on the stain level.
- Ceramic Plate**
Place on the Wire Rack. Place food on the Ceramic Plate.
- Pizza Plate**
Place on the Wire Rack. Place food on the Pizza Plate.
- Wire Rack**
Place on the Ceramic Tray.
- Ceramic Tray**
Place on the Base Plate Liner. Use as a drip tray for the food.
- Base Plate Liner**
Place on the bottom surface of the oven. Use to prevent the food and oil stains.
● It is recommended to replace it every 3 to 6 months depending on the stain level.

Parts of your Oven

Front

Door Handle

Door
Opening this while cooking will stop the operation.

Intake Vent

Note

Always install the air filter, drip tray, and front cover before using the oven. Continuous use of the oven without these parts will result in malfunction.

Back

Exhaust Vent

Catalyst
The oil smoke that circulates inside the oven cavity is decomposed and purified by going through the catalyst converter.

- The catalyst reaction will lower when the cooking temperature is low [approximately 475°F (250°C) or lower].

Power Supply Plug

Please only plug in to outlets compatible with 20 Amp Plug to NEMA #6-20P. Equipment is dedicated to single phase power supply.

- Illustrations may differ to the actual items. Caution labels are affixed to the actual oven.

GROUNDING

IMPORTANT: FOR PERSONAL SAFETY, THIS OVEN MUST BE PROPERLY GROUNDED. When an outlet is not grounded, it is personal responsibility and obligation of the customer to have it replaced with a properly grounded outlet.

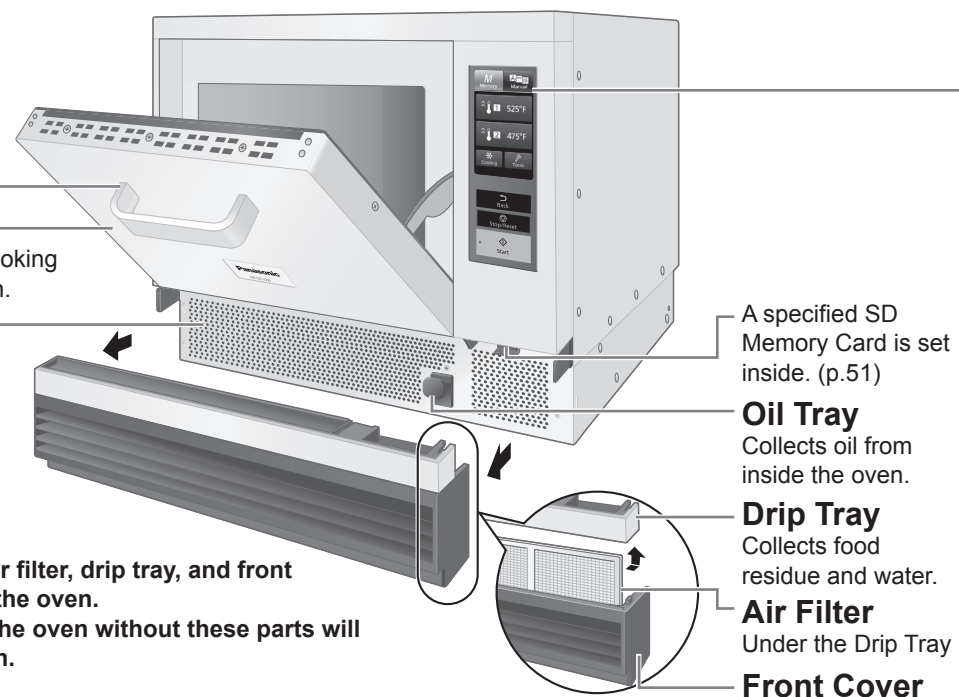

A specified SD Memory Card is set inside. (p.51)

Oil Tray

Collects oil from inside the oven.

Drip Tray

Collects food residue and water.

Air Filter

Under the Drip Tray

Front Cover

- How to remove the front cover, drip tray, air filter, and oil tray. (p.44)

An external equipotential bonding conductor is provided at the back side of the oven and it is marked by this symbol.

Control Panel (initial screen)

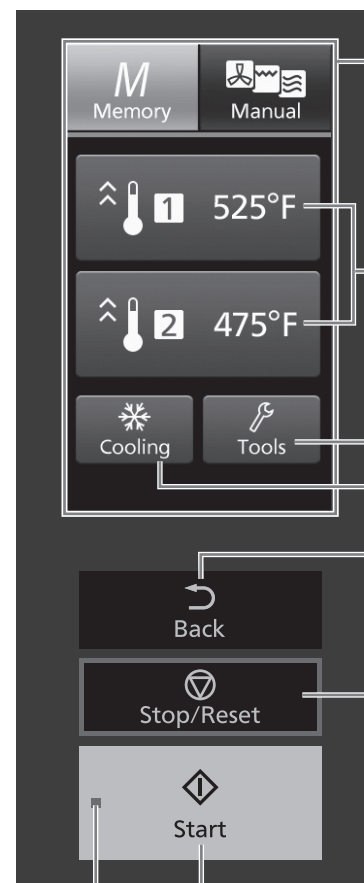

Touch Screen (display) (p.20)

- Tap on the screen directly to use the controls.
- Shows details such as the cooking temperature, cooking time, stored cooking program, beep information, and so on.
- Do not touch the screen with a sharp object. Doing so will cause damage.

Please contact a service agent to change the temperature display from Fahrenheit to Celsius.

Tools (pp.23–27)

Cooling (p.22)

Back Pad

- Returns to the previous control screen so that settings can be changed.
- Unavailable after cooking has started.

Stop/Reset Pad

- Press once to temporarily stop the cooking process. To resume cooking, press the Start pad.
- Press twice to clear your instructions (returns to the initial screen) or cancel cooking.
- Press once to cancel cooking of a stored program when the memory lock is turned on.

Lamp

Start Pad

- After setting preheating or cooling, press this pad.
- After preheating, setting memory cooking or manual cooking and press this pad to start cooking.
- The lamp will flash to encourage you to press the pad.

■ Auto Power OFF Function

The initial screen of the display turns off automatically if it is not used for 5 minutes.

■ To turn the power ON

In Auto Power OFF mode, opening the door turns the power ON.

How to Operate the Touch Screen

Memory

When cooking with the stored heating program → “Cooking with a Saved Cooking Program” (p.41)

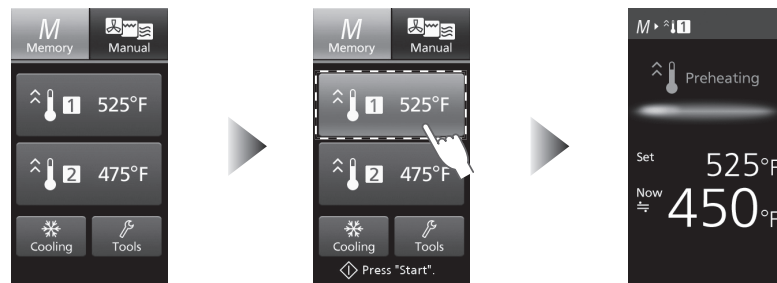

- Approximate preheating time; 525°F (280°C): 7 min. 475°F (250°C): 6 min.

● The **Memory** cooking screen is the initial screen.

● You can change the preheat temperature. (p.25)



● After preheating is finished, you can select a menu when you open the door.

Manual

When cooking manually → “Manual Cooking” (pp.29–35)

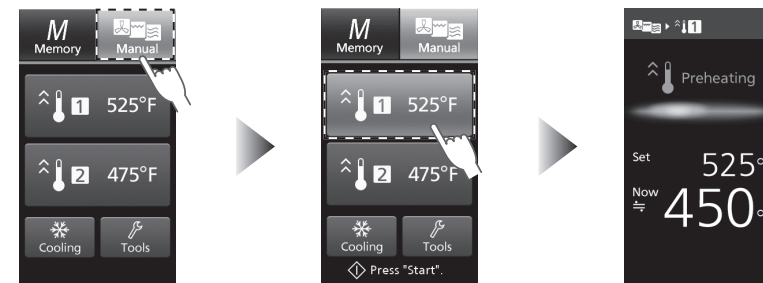

- Approximate preheating time; 525°F (280°C): 7 min. 475°F (250°C): 6 min

● Select **Manual**.

● You can change the preheat temperature. (p.25)

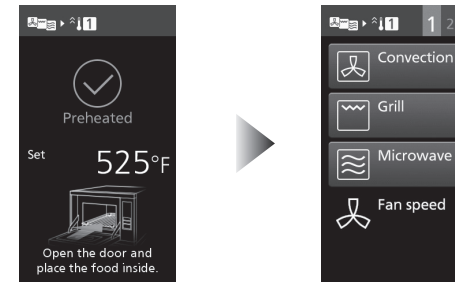

● After preheating is finished, you can select the cooking mode when you open the door.

How to Operate the Touch Screen

Cooling

The inside of the oven can be cooled when the cavity is hot after cooking.

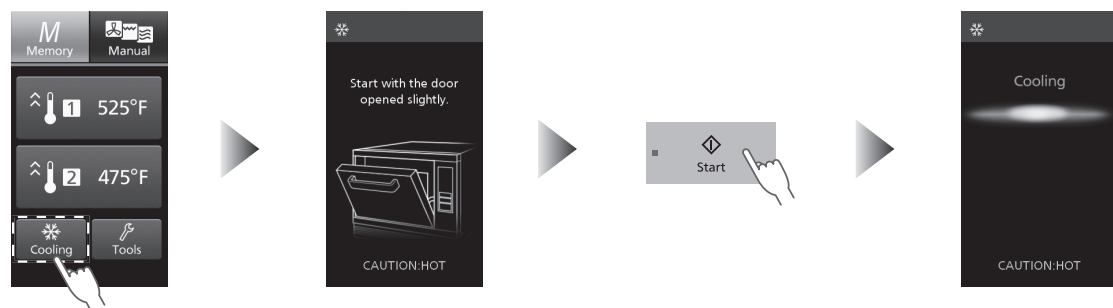

- Open the door slightly to lock it in place. (Keep your face away.)

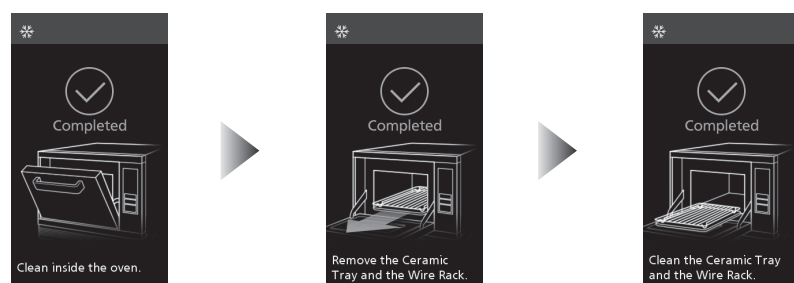

- The cooling time depends on the temperature inside the oven. (up to 45 minutes)

CAUTION

Be careful of hot air when opening door.

Tools

You can change and confirm various settings, such as memory or beep.

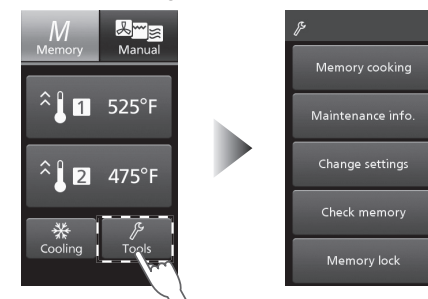

- When memory lock is ON, **Memory cooking** and **Change settings** are not displayed.

Memory cooking

- This feature cannot be used when memory lock is ON. Please cancel memory lock. (p.27)

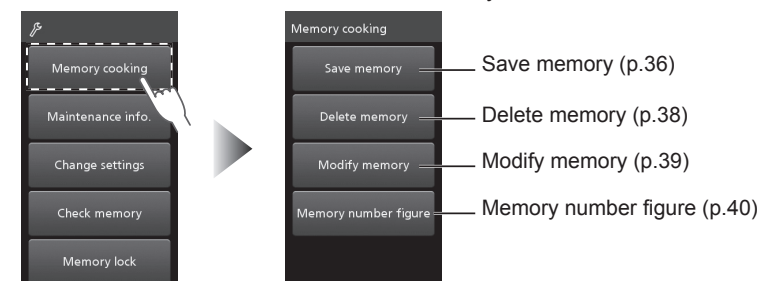

- Save memory (p.36)
- Delete memory (p.38)
- Modify memory (p.39)
- Memory number figure (p.40)

Maintenance info.

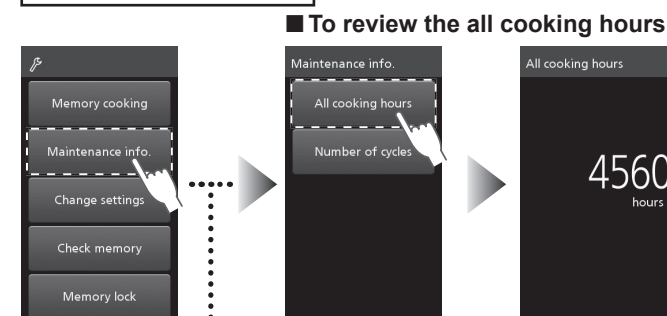

■ To review the all cooking hours (including preheating)

Notes

- The highest figure of the counter is 999999 hours. It returns to "0" the next time it is used.
- A total of all cooking hours is rounded down to the nearest hour.

e.g.)

All cooking hours	Display
59 min	0
1 hr 59 min	1

- Returns to the initial screen after 3 seconds.

■ To review the number of cycles (including preheating)

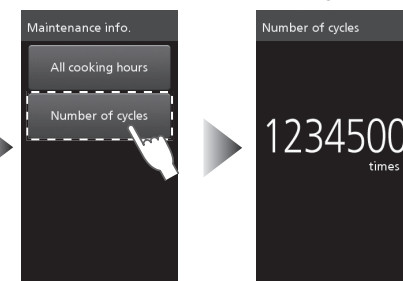

Notes

- The highest figure of the counter is 3999999 times. It returns to "0" the next time it is used.
- If you start cooking again after a pause in the middle, it also counts as a new cycle.
- The last two figures of the total number of cycles are rounded down.

e.g.)

Number of cycles	Display
99 times	0
101 times	100
1100 times	1100

- Returns to the initial screen after 3 seconds.

How to Operate the Touch Screen Tools

Change settings

- This feature cannot be used when memory lock is ON. Please cancel memory lock. (p.27)

Beep

To change the loudness of the beep (Default setting: Level3)

- Depending on the setting, **Pitch of beep clean** may be displayed.
- Select the loudness with **+** or **-**, and tap **OK**.

To change the length of beep at the end of program (Default setting: Type1)

- Type1 — Beeps in three short pulses every 15 seconds
- Type2 — Beeps in longer pulses continuously
- Type3 — Beeps in one long pulse then beeps in three longer pulses every 30 seconds
- The beep stops when you open the door.
- Select the length of beep and tap **OK**.

To change the tone pitch of the beep at the end of program (Default setting: Normal)

- Select the tone pitch and tap **OK**.

To select ON or OFF for the preheated beep (Default setting: ON)

To select ON or OFF for the door alarm (Default setting: ON)

- Select **Preheated beep** or **Door alarm**.
- Select **ON** or **OFF**, and tap **OK**.

The oven returns to the initial screen after displaying the settings for 3 seconds.

Preheat temperature

- You can change the preheat temperature displayed on the initial screen.
 [Default setting: Preheat 1 → 525°F (280°C), Preheat 2 → 475°F (250°C)]
- Please note that the preheat temperature previously saved for the memory cooking (p.36) will also be changed if you change the setting here.

- Select **Preheat1** or **Preheat2**.
- Set Required temp. From 350°F (180°C) to 525°F (280°C) in 25°F increments.
- Set Cook available temp. From 350°F (180°C) to 525°F (280°C) in 25°F increments.

● Returns to the initial screen after 3 seconds.

LCD brightness

You can choose the brightness of the touch screen.

(Default setting: Level3)

Bright ↑
Dark ↓

- Select the brightness with **+** or **-**, and tap **OK**.

The oven returns to the initial screen after displaying the settings for 3 seconds.

How to Operate the Touch Screen

Tools

Check memory

Memory list Saved cooking contents, beep, and memory lock setting, etc. are displayed in order every 4 seconds.

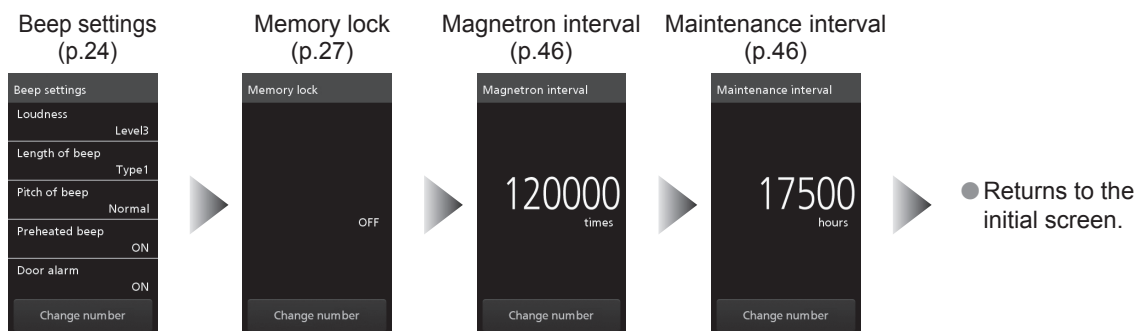
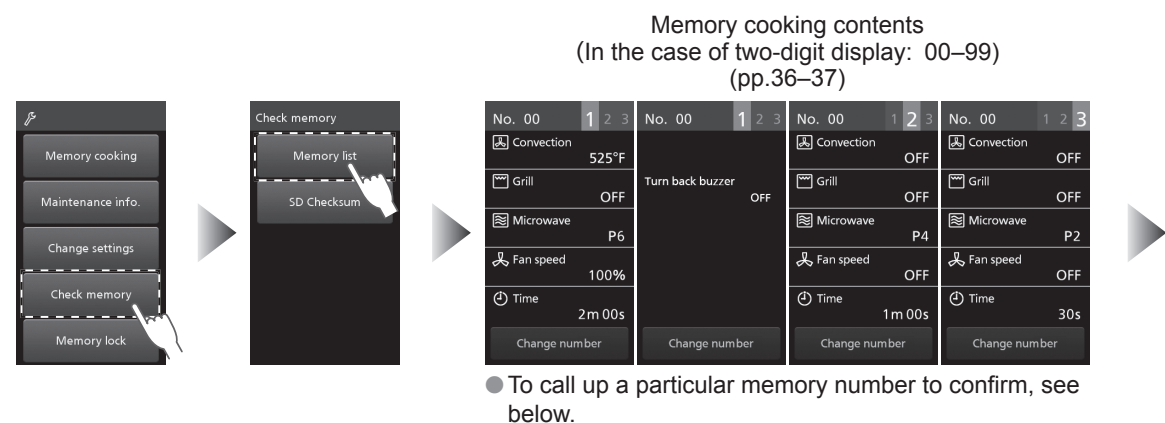

● In order to call up a particular memory number to confirm, press the Stop/Reset pad while the display is changing, then tap **Change number**, enter the memory number, and tap **OK**. The memory contents are displayed by pressing the Start pad.
(e.g.: To call up memory number 52)

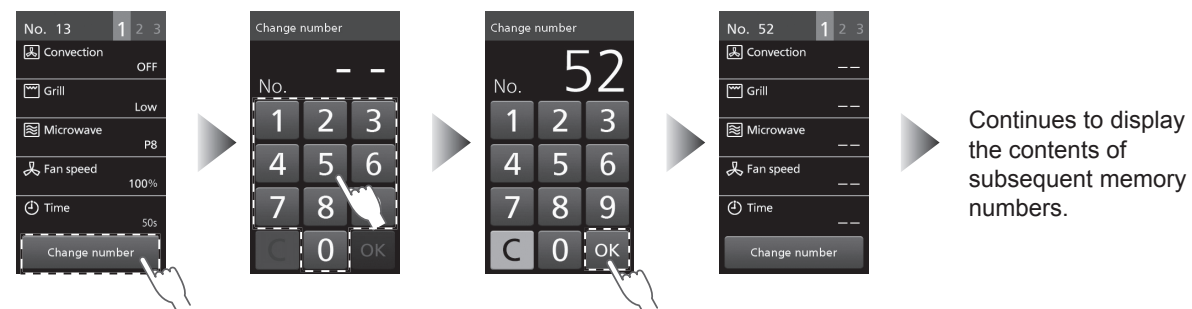

SD Checksum

Use to confirm whether the contents of multiple SD Memory Cards are the same.
The memory contents in the SD Memory Card are displayed as four-figure alphanumeric characters.
If the alphanumeric characters are the same, the memory contents of those SD Memory Cards are the same.

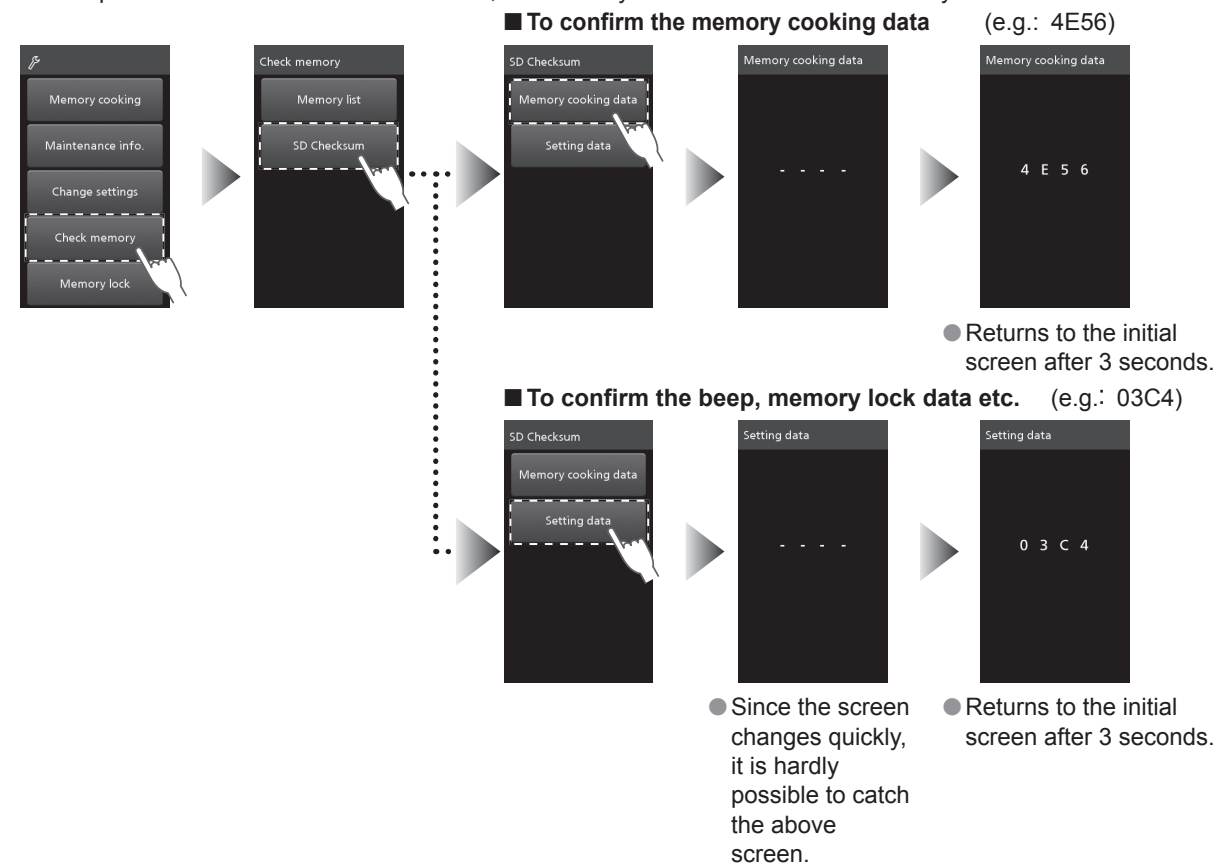

Memory lock

You can choose memory lock ON or OFF.
(Default setting: OFF)

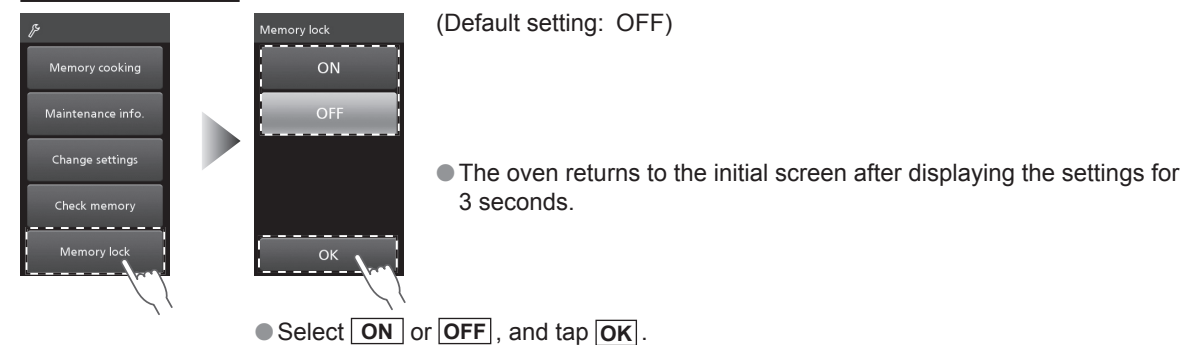

Notes

■ **When the memory lock is ON**

- Memory cooking starts automatically after you select a memory number even without pressing the Start pad.
- **Memory cooking** and **Change settings** are not displayed.

■ **When the memory lock is OFF**

- Memory cooking starts when you press the Start pad after entering the memory number.

Preheating

Use the preheating function to warm up the oven in advance.

1 525°F (280°C) and **2 475°F** (250°C) are set as default.

Preheating will resume automatically every time cooking has finished once the preheating has been set.

● Set the provided Base Plate Liner, Ceramic Tray, Wire Rack, and other accessories suitable for the intended cooking mode, in the oven before starting preheating, except Oven Sheet and Aluminum Paddle.

(e.g.: **Memory**, **1 525°F**)

1 Select **1 525°F**



2 Press the Start pad

- Pausing or opening and closing the door during preheating will automatically resume preheating after 10 seconds.

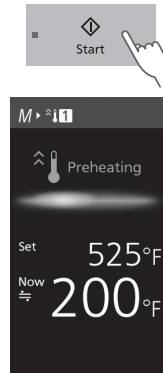

3 Preheating has been completed

- Approximate preheating time:
525°F (280°C): 7 min.
475°F (250°C): 6 min.

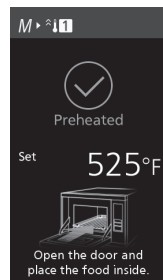

- The default setting is that the beep sounds after preheating is complete. After putting the food into the oven, close the door immediately and set memory cooking (p.41) or manual cooking (pp.29–35).
- You can turn off the beep.
“To select ON or OFF for the preheated beep” (p.24)
- If you leave the door open during preheating or after preheating is complete, the beep sounds after 30 seconds and 50 seconds.
- If the pads are not used after preheating is complete, preheating will be cancelled after 4 hours.

■ To cancel preheating

Press the Stop/Reset pad twice.

Manual Cooking

Convection Cooking

(e.g.: **Manual**, Preheating 525°F (280°C), Convection 525°F (280°C), Fan speed 100 %, 10 min 30 sec)

1 After **Manual** preheating, select **Convection**

- “Preheating” (p.28)

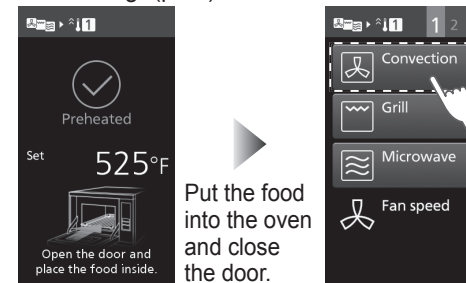

Put the food into the oven and close the door.

2 Set the oven temperature, and tap **OK**

- From 350°F (180°C) to 525°F (280°C) in 25°F increments
- Tap **OFF** to cancel the already selected cooking process.

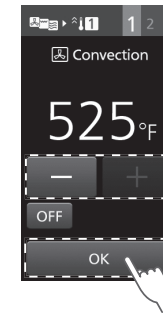

3 Set **Fan speed**, and tap **OK**

- From 30 % to 100 % in 10 % increments
- “Fan Speed” (p.13)

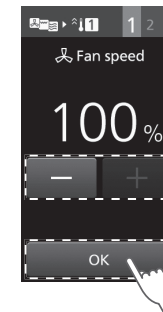

4 Tap **Set time**

- Tap **Convection** and **Fan speed** when changing those settings.



5 Set the cooking time

- Maximum cooking time: 30 min.
- Tap **Next** when setting Step 2.
“Cooking in Steps” (p.34)

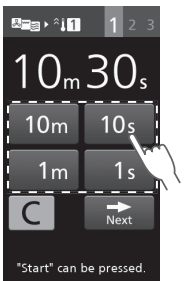

6 Press the Start pad (Cooking will start.)

- Tap **Recall** when verifying the settings for the current step.

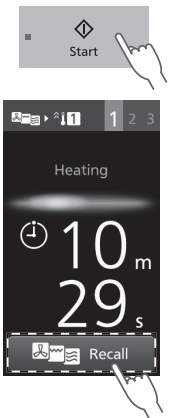

Notes

- Holding down the pad moves the temperature, fan speed, and time forward faster. This is convenient for setting a longer cooking time, and so on.
- After a cooking has finished, the cooking process can be saved into the SD Memory Card. (p.36)

Manual Cooking

Grill Cooking

(e.g.: **Manual**, Preheating 525°F (280°C), Grill High, Fan speed 100 %, 10 min 30 sec)

1 After **Manual** preheating, select **Grill**

- “Preheating” (p.28)



Put the food into the oven and close the door.

2 Select **High**

- Tap **OFF** to cancel the already selected cooking process.

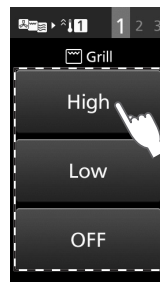

3 Set **Fan speed**, and tap **OK**

- From 30 % to 100 % in 10 % increments
- “Fan Speed” (p.13)

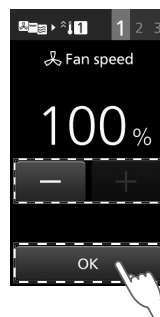

4 Tap **Set time**

- Tap **Grill** and **Fan speed** when changing those settings.

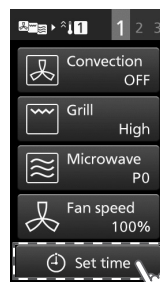

5 Set the cooking time

- Maximum cooking time: 30 min.
- Tap **Next** when setting Step 2. “Cooking in Steps” (p.34)

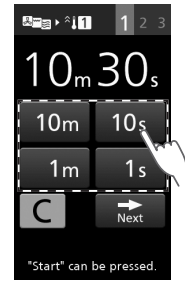

6 Press the **Start** pad (Cooking will start.)

- Tap **Recall** when verifying the settings for the current step.

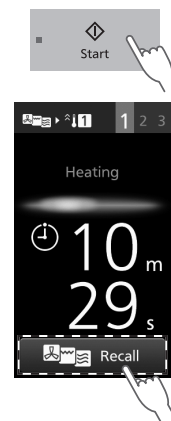

Notes

- Holding down the pad moves the temperature, fan speed, and time forward faster. This is convenient for setting a longer cooking time, and so on.
- After a cooking has finished, the cooking process can be saved into the SD Memory Card. (p.36)

Convection-and-Grill Cooking

(e.g.: **Manual**, Preheating 525°F (280°C), Convection 525°F (280°C), Fan speed 100 %, Grill High, 2 min 30 sec)

1 After **Manual** preheating, select **Convection**

- “Preheating” (p.28)

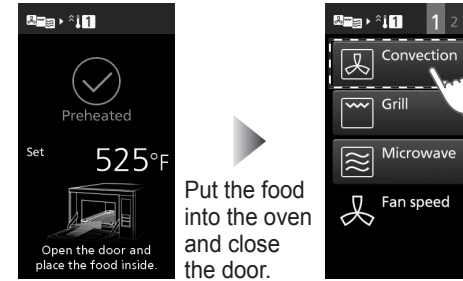

Put the food into the oven and close the door.

2 Set the oven temperature, and tap **OK**

- From 350°F (180°C) to 525°F (280°C) in 25°F increments
- Tap **OFF** to cancel the already selected cooking process.

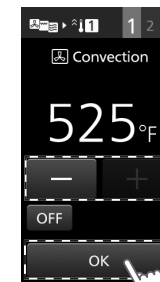

3 Set **Fan speed**, and tap **OK**

- From 30 % to 100 % in 10 % increments
- “Fan Speed” (p.13)

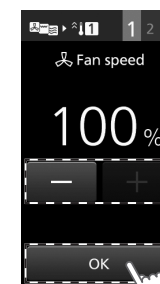

4 Select **Grill**



5 Select **High**

- Tap **OFF** to cancel the already selected cooking process.

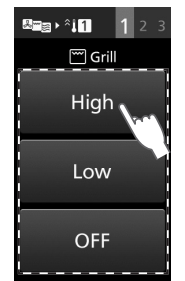

6 Tap **Set time**

- Tap **Convection**, **Grill** and **Fan speed** when changing those settings.

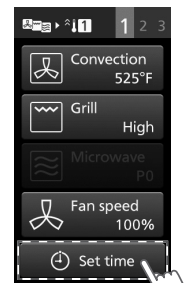

7 Set the cooking time

- Maximum cooking time: 30 min.
- Tap **Next** when setting Step 2. “Cooking in Steps” (p.34)

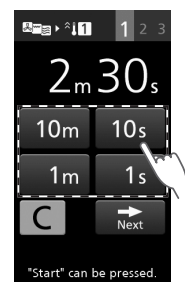

8 Press the **Start** pad (Cooking will start.)

- Tap **Recall** when verifying the settings for the current step.

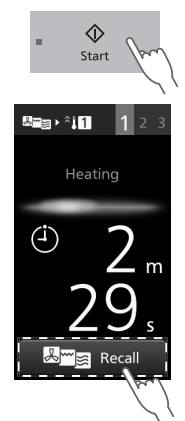

Notes

- Holding down the pad moves the temperature, fan speed, and time forward faster. This is convenient for setting a longer cooking time, and so on.
- After a cooking has finished, the cooking process can be saved into the SD Memory Card. (p.36)

Manual Cooking

Convection-and-Microwave Cooking

(e.g.: **Manual**, Preheating 525°F (280°C), Convection 525°F (280°C), Fan speed 100 %, Microwave P3, 1 min 30 sec)

1 After **Manual** preheating, select **Convection**

- “Preheating” (p.28)



Put the food into the oven and close the door.

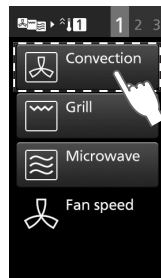

2 Set the oven temperature, and tap **OK**

- From 350°F (180°C) to 525°F (280°C) in 25°F increments
- Tap **OFF** to cancel the already selected cooking process.

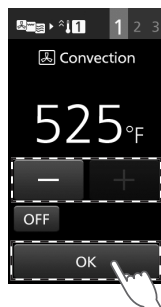

3 Set **Fan speed**, and tap **OK**

- From 30 % to 100 % in 10 % increments
- “Fan Speed” (p.13)

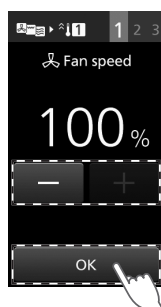

4 Select **Microwave**

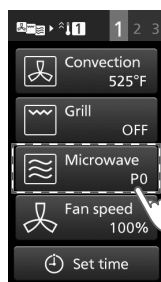

5 Select the microwave power

- From P0 to P8

Display	Power	Display	Power
P8	1200 W	P3	500 W
P7	1050 W	P2	300 W
P6	900 W	P1	200 W
P5	750 W	P0	0 W
P4	600 W		

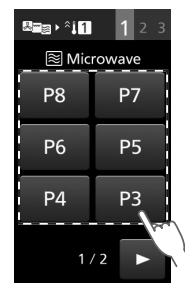

6 Tap **Set time**

- Tap **Convection**, **Microwave** and **Fan speed** when changing those settings.



7 Set the cooking time

- Maximum cooking time: 3 min.
- Tap **Next** when setting Step 2. “Cooking in Steps” (p.34)

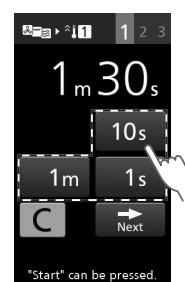

8 Press the **Start** pad (Cooking will start.)

- Tap **Recall** when verifying the settings for the current step.

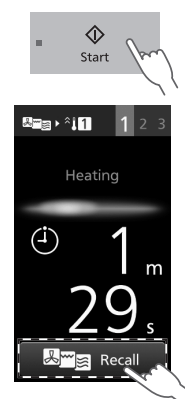

Notes

- Holding down the pad moves the temperature, fan speed, and time forward faster. This is convenient for setting a longer cooking time, and so on.
- After a cooking has finished, the cooking process can be saved into the SD Memory Card. (p.36)

Grill-and-Microwave Cooking

(e.g.: **Manual**, Preheating 525°F (280°C), Grill High, Fan speed 100 %, Microwave P3, 1 min 30 sec)

1 After **Manual** preheating, select **Grill**

- “Preheating” (p.28)



Put the food into the oven and close the door.

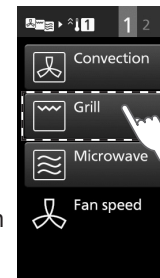

2 Select **High**

- Tap **OFF** to cancel the already selected cooking process.

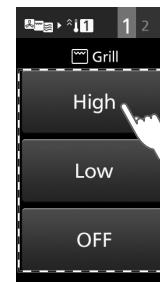

3 Set **Fan speed**, and tap **OK**

- From 30 % to 100 % in 10 % increments
- “Fan Speed” (p.13)

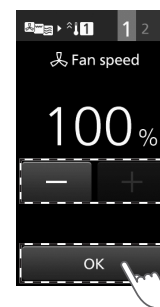

4 Select **Microwave**



5 Select the microwave power

- From P0 to P6*

Display	Power	Display	Power
P6	900 W	P2	300 W
P5	750 W	P1	200 W
P4	600 W	P0	0 W
P3	500 W		

*You can also select P7 (1050 W) and P8 (1200 W) when using Grill Low.

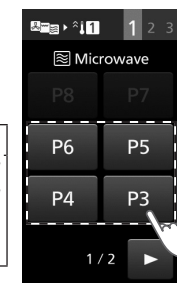

6 Tap **Set time**

- Tap **Grill**, **Microwave** and **Fan speed** when changing those settings.

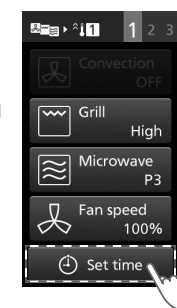

7 Set the cooking time

- Maximum cooking time: 3 min.
- Tap **Next** when setting Step 2. “Cooking in Steps” (p.34)

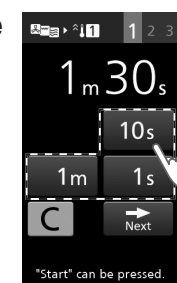

8 Press the **Start** pad (Cooking will start.)

- Tap **Recall** when verifying the settings for the current step.

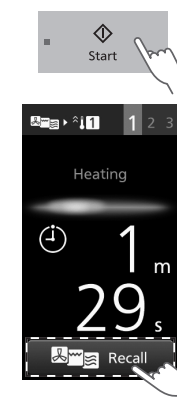

Notes

- Holding down the pad moves the temperature, fan speed, and time forward faster. This is convenient for setting a longer cooking time, and so on.
- After a cooking has finished, the cooking process can be saved into the SD Memory Card. (p.36)

Manual Cooking

Cooking in Steps

The microwave power, temperature, cooking time or other can be set for up to three continuous steps.
Use Convection, Grill and Microwave functions to suit your recipe.

e.g.: **Manual**, Preheating 525°F (280°C) → **Step 1** Convection 525°F (280°C), Fan speed 100%, Microwave P5, 1 min → **Step 2** Microwave P4, 50 sec → **Step 3** Grill High, Fan speed 30%, 30 sec

● You can use microwave only cooking at Step 2 and Step 3 in Cooking in Steps.

Step 1

- After **Manual** preheating, select **Convection**
- Set the oven temperature, and tap **OK**
- Set **Fan speed**, and tap **OK**
- Select **Microwave**
- Select the microwave power
- Tap **Set time**
- Set the cooking time, and tap **Next**

● "Preheating" (p.28)

■ Maximum power and cooking time for Convection-and-Microwave/Grill-and-Microwave cooking

	Maximum microwave power	Maximum cooking time
Step 1	P8 (1200 W)*	3 min.
Step 2	P4 (600 W)	3 min.
Step 3	P2 (300 W)	10 min.

*You cannot select P7 (1050 W) and P8 (1200 W) when using Grill High.

● Maximum cooking time for Convection/Grill/Convection-and-Grill is 30 minutes for each step.

Step 2

- Select **Microwave**
- Select **P4**
- Tap **Set time**
- Set the cooking time, and tap **Next**

Step 3

- Select **Grill**
- Select **High**
- Set **Fan speed**, and tap **OK**
- Tap **Set time**
- Set the cooking time

Press the Start pad.

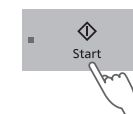

● The oven starts cooking in order from Step 1 → Step 2 → Step 3.

Notes

- Holding down the pad moves the temperature, fan speed, and time forward faster. This is convenient for setting a longer cooking time, and so on.
- After a cooking has finished, the cooking process can be saved into the SD Memory Card. (p.36)
- When "Turn back buzzer" is enabled, the buzzer beeps between steps when using the Cooking in Steps feature. (p.52)

Memory Cooking

e.g.: **Memory**, Preheating 525°F (280°C) → **Step 1** Convection 525°F (280°C), Fan speed 100 %, Microwave P6, 1 min → **Step 2** Convection 525°F (280°C), Fan speed 60 %, 50 sec → **Step 3** Grill High, Fan speed 30 %, 30 sec

Memory number: 37

How to Save Memory

There are two methods to save memory cooking – saving a cooking program after manual cooking and saving a cooking program in advance.

Up to 1000 programs of cooking programs can be saved to the memory.

[You can also set 10 programs, and default setting is 100 programs. (p.40)]

● The default menu is registered in No. 00–No. 18.

It is useful to cook everyday menus.

You can also overwrite, change or erase previously saved contents.

● This feature cannot be used when memory lock is ON. Please cancel memory lock. (p.27)

Save the program after manual cooking

1 After cooking is complete, take the food out

- After taking out the food, you can save the cooking program.

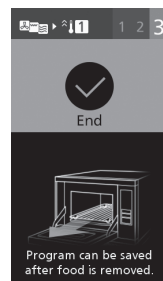

2 Tap **Memory**

- Tap **Cancel** to return to the initial screen.

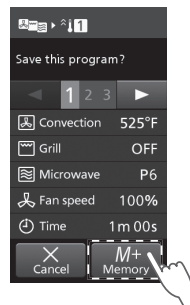

3 Enter the desired memory number

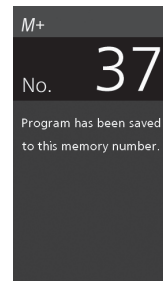

- When the memory number is empty

Save successful
Returns to the initial screen after 3 seconds.

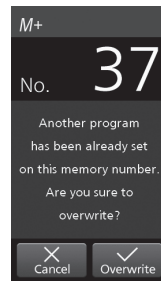

- When the memory number is already used
- Tap **Overwrite** and this screen appears.

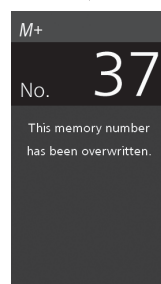

Save successful
Returns to the initial screen after 3 seconds.

Save a program in advance

1 Select **Tools**

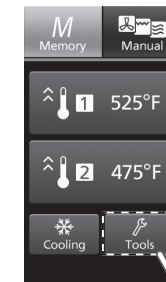

2 Select **Memory cooking**

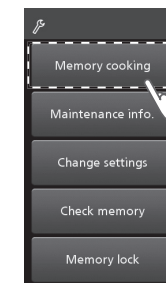

3 Select **Save memory**

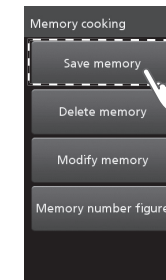

4 Enter the desired memory number and tap **OK**



5 Select preheating

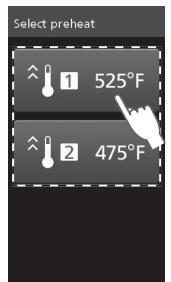

Carry out procedures 1 to 6 of Step 1 of “Cooking in Steps” (p.34)

6 Set the cooking time, and tap **Next**

- Tap **Memory** here to display the confirmation screen and complete.

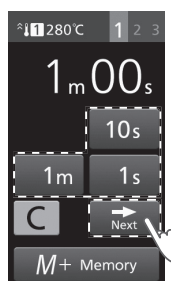

Carry out procedures 1 to 4 of Step 2 of “Cooking in Steps” (p.35)

7 Set the cooking time, and tap **Next**

- Tap **Memory** here to display the confirmation screen and complete.

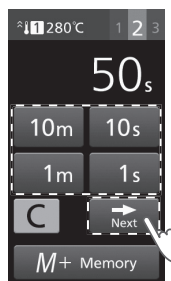

Carry out procedures 1 to 4 of Step 3 of “Cooking in Steps” (p.35)

8 Set the cooking time, and tap **Memory**

- The oven returns to the initial screen after displaying the confirmation screen for 3 seconds.

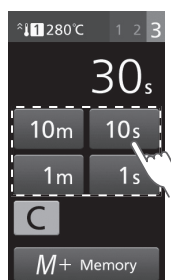

Please note that the preheat temperature saved for the memory cooking will be changed if you change the setting of Preheat temperature. (p.25)

Memory Cooking

How to Delete Memory

● This feature cannot be used when memory lock is ON. Please cancel memory lock. (p.27)

1 Select **Tools**



4 Enter the memory number to delete and tap **OK**



2 Select **Memory cooking**

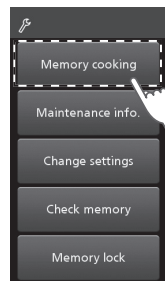

5 Confirm the data and tap **Delete**

- The oven returns to the initial screen after displaying the confirmation screen for 3 seconds.
- Tap **Cancel** to return to the procedure 4.

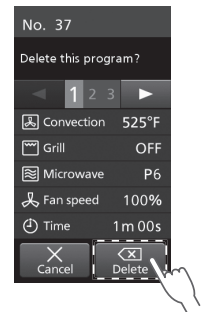

3 Select **Delete memory**

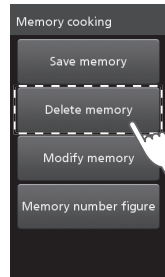

How to Modify Memory

● This feature cannot be used when memory lock is ON. Please cancel memory lock. (p.27)

1 Select **Tools**



5 The previously saved program is displayed. Modify the item you want to change as per the instructions written in "Save a program in advance" (p.37)

2 Select **Memory cooking**

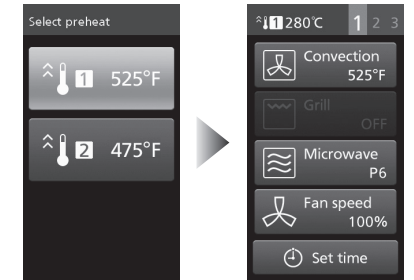
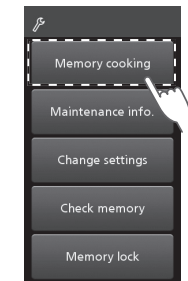

3 Select **Modify memory**

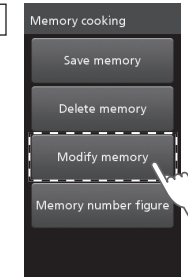

6 Tap **Memory**

- The oven returns to the initial screen after displaying the confirmation screen for 3 seconds.

4 Enter the memory number to edit and tap **OK**

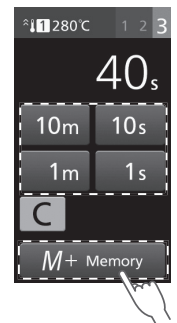

Memory Cooking

How to Set the Memory Number Figure

The number of figures for the memory number is set to double as default setting (100 programs: 00–99). You can also set single-figure (10 programs: 0–9) or triple figures (1000 programs: 000–999).

● This feature cannot be used when memory lock is ON. Please cancel memory lock. (p.27)

1 Select **Tools**



4 Select the desired number of figures and tap **OK**

● The oven returns to the initial screen after displaying the settings for 3 seconds.



2 Select **Memory cooking**

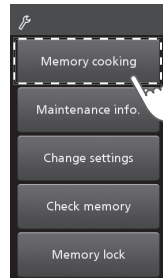

3 Select **Memory number figure**

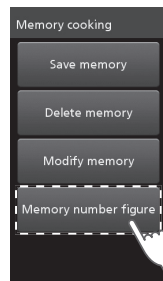

Cooking with a Saved Cooking Program

1 Select **1 525°F**



2 Press the **Start** pad

● Pausing or opening and closing the door during preheating will automatically resume preheating after 10 seconds.

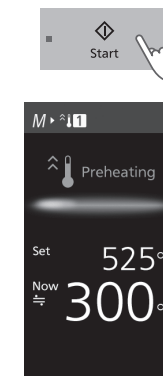

3 Preheating has been completed



4 Select a menu after putting the food into the oven and close the door

● **ON** is displayed on the screen when memory lock is ON.
● When memory lock is ON, cooking starts automatically.

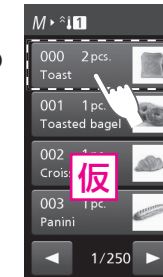

5 The program is displayed

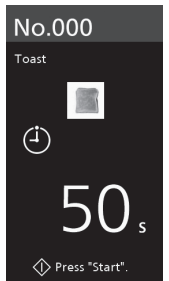

6 Press the **Start** pad (Cooking will start.)

● Tap **Recall** when verifying the settings for the current step.
● When memory lock is OFF, cooking starts after pressing the Start pad.

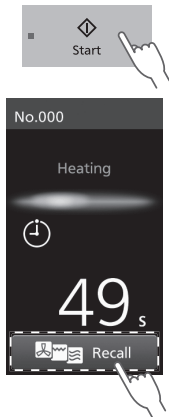

Care of your Oven

It is essential that you follow these points to get the maximum use from your oven. Microwaves are attracted to moisture and grease: therefore a dirty oven does not cook EFFICIENTLY. Failure to maintain the oven in a clean condition could lead to deterioration of the surface that could adversely affect the life of the appliance and possibly result in a hazardous situation.

- This oven requires regular maintenance. (p.46)

⚠ WARNING

- **Pull out the power plug before maintenance.**
If not, this may result in electric shock.
- **Wait for the oven cavity to cool down first before cleaning.**
If not, this may result in burns and injuries.

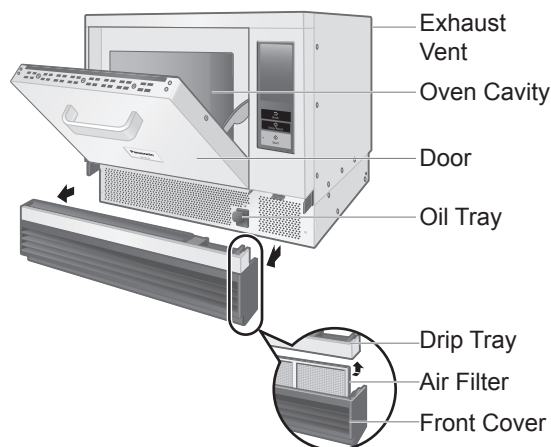

■ Before Cleaning

- Do not clean this oven with a water jet.
- Do not pour detergent and leftover food into the gap and punching holes. This will result in a malfunction.
- If the oven becomes damaged in any way, contact the dealer or a service agent before continuing use.
- Only part that is dishwasher-safe is the Wire Rack. It is prohibited for other accessories, since they may deteriorate due to detergent (possibility of strong alkaline used), or chipping or cracking due to ceramic parts hitting each other under strong water stream.

Clean these parts Every Day.

■ Oven Cavity • Door Inner Side • Door Seal

Wipe with a damp cloth

Thoroughly wipe away water, oil, and leftover food stains frequently to prolong the use of the oven. Failure to remove burnt food and dust may cause rust.

If the stains are bad, wipe away with a cloth soaked in a neutral kitchen detergent.

- Do not use alkaline detergent.
- If the stains are even worse, only for the metal part on the inner side of the door, you can use an abrasive cleanser with a hard scrubber.

- Do not scrape the parts other than the metal part inside the door (door seal area etc.) with a hard scrubber, which may cause damage of the door seal and malfunction of the oven. Be sure to use only a soft scrubber.
- Do not splash detergent directly onto the top and rear surfaces of oven cavity. This will result in a malfunction.

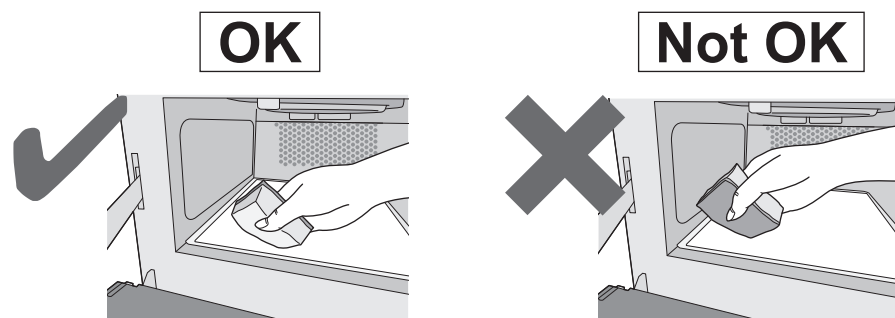

■ Outer Areas

Wipe with a damp cloth

Wipe away oil and food stains immediately.

- Do not use thinner, benzene, abrasive cleanser, bleaching agent, alkaline residential or household synthetic detergent.

If the stains are bad, wipe away with a cloth soaked in a neutral kitchen detergent. Take care not to allow the kitchen detergent to enter the exhaust vent and gaps.

- Outer side of the door • handle area
After wiping with a wet cloth, wipe the areas with soft, dry cloth.

■ Ceramic Tray • Wire Rack • Ceramic Plate • Pizza Plate • Oven Sheet • Aluminum Paddle • Base Plate Liner

- Be careful not to rub on the Base Plate Liner when removing accessories.

Wash with a soft scrubber soaked in a neutral kitchen detergent

- Do not use alkaline detergent.

Clean them every time you use them if the stains become a concern. Only when the dirt is severe, wipe away dirt with rollup plastic wrap or aluminium soaked in water and abrasive cleanser.

- Except for Base Plate Liner, Oven Sheet, and Aluminum Paddle.
- Do not wash in the Dish Washer.

PTFE coating may peel off, or ceramic product may crack.

Disassemble and clean this part Every Day.

■ Drip Tray



Wipe with a damp cloth

- Refer to "How to remove/attach parts". (p.44)
- Do not use alkaline detergent.

Disassemble and clean these parts Once a Week.

- Refer to "How to remove/attach parts". (p.44)

■ Front Cover

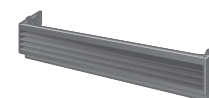

Wipe with a damp cloth

Wipe away oil and food stains immediately. If the stains are bad, wipe away with a cloth soaked in a neutral kitchen detergent.

- Do not use alkaline detergent.

■ Air Filter

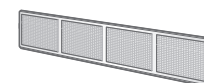

Dry after washing with water

Clean it after every use if the stains are bad. The filter may lose its effect if the stains are left behind. The temperature of the internal parts may also rise, resulting in a malfunction.

■ Oil Tray

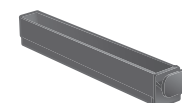

Wipe away oil stains with a soft cloth or paper towel

If the stains are bad, clean the area with a soft scrubber dipped in a neutral kitchen detergent and dry.

- Do not use alkaline detergent.

Care of your Oven

■How to remove/attach parts

Front Cover

● Removing

Pull out the front cover and remove it.

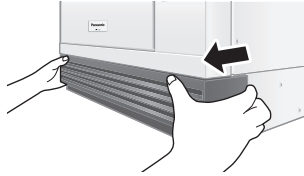

● Attaching

Install the main unit (A) into the groove of the drip tray.

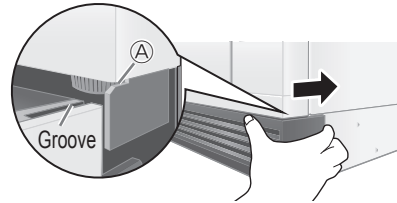

Drip Tray/Air Filter

● Removing

Remove the front cover, and then press and shift both ends of the drip tray to detach. Then, pull out the air filter.

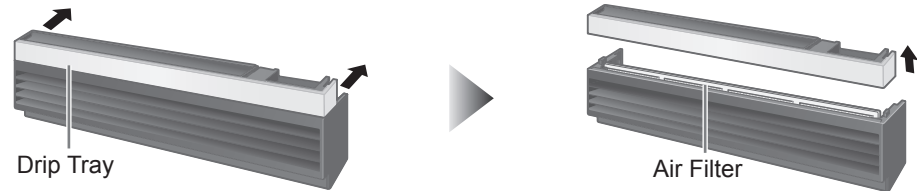

● Attaching

Insert the air filter into the groove on the front cover all the way inside, then place the drip tray back in the original position.

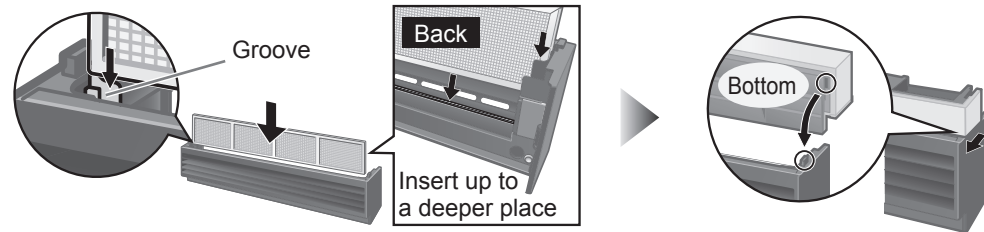

Oil Tray

● Removing

Remove the front cover first, and take out the oil tray.

● Attaching

Follow the reverse procedure to install the oil tray.

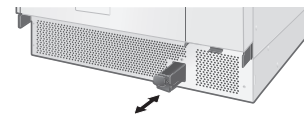

Clean this part once a month.

■Exhaust Vent

Clean the rear exhaust vent with a toothbrush and a towel

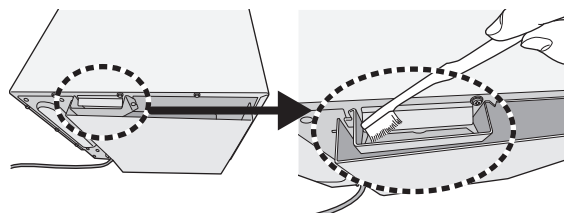

■Kitchen counter surface

For single Installation

•Wait until it cools down. Please see p.22 if the oven is hot.

● Remove the Air Filter from the Microwave Oven.

● Remove all the accessories from the oven cavity.

When removing all the accessories or when cooling it down by Cool Down Operation. (p.22) Please be careful because it may still be hot.

● You can move the Microwave Oven.

Move the Microwave Oven to other location and wipe it on the kitchen counter. Please be careful when moving the oven because it may be very heavy. We recommend it to be moved by two people.

For stacking

Please contact the dealer or an authorized service center according to the situation of the kitchen. Please seal it with Silicone Sealant after service as described in p.10.

Regular Maintenance

When one of the following is displayed, oven maintenance is required. Continuing to use the oven may cause failure.

Please contact the dealer or a service agent promptly. (p.3)

- Displays until maintenance is done when the power plug is removed and reinserted or when there has been no operation for a while. In addition, the oven will beep 6 times after completing cooking regardless of the settings.

Display	Cause
It is time to perform regular maintenance.	<ul style="list-style-type: none"> ● Displays when the oven has been used for 17,500 hours. Please contact the dealer or a service agent to replace the parts.
It is time to replace the Magnetrons in this oven.	<ul style="list-style-type: none"> ● Displays when the magnetron has been used 120,000 times. Please contact the dealer or a service agent to replace the parts.

- The above time and number of operations is not a guarantee.

Troubleshooting

Troubleshoot following the next procedure when there is a problem.

Symptom	Cause
It does not operate at all	<ul style="list-style-type: none"> ● Is there a power outage? ● Is the breaker in the power distribution board tripped, or the power supply plug unplugged? ● Is the initial screen displayed in the control panel? If the auto power OFF function is in operation, perform the operation after the initial screen is displayed by opening the door.
It does not cook correctly	<ul style="list-style-type: none"> ● Is the cook setting, accessory, or the cook time incorrect? ● Has the oven been sufficiently preheated?
There is a sound	<ul style="list-style-type: none"> ● There will be a sound of cooking starting, and the fan will sound.
There is smoke or harsh odor	<ul style="list-style-type: none"> ● A smoke or harsh odor may occur due to burning of the oil for oven cavity protection when the heater is turned on for the first time. Always ventilate and perform a blank baking if it concerns you. (p.10)
There are sparks during cooking	<ul style="list-style-type: none"> ● A metal container can only be used in the oven when not using microwave power. (p.11) ● Is a container containing gold or silver particles used? ● Is any metal (aluminium foil, metallic skewer, etc.) touching the wall of the oven cavity? ● Is the oven cavity rusted? Rust may cause sparks.
The buzzer does not beep	<ul style="list-style-type: none"> ● Is the loudness of the beep set to OFF? The buzzer will not beep when it is set to OFF. (p.24)
There is an odor or smoke	<ul style="list-style-type: none"> ● This is not a malfunction. The catalyst reaction will lower when the cooking temperature is low (approximately 475°F (250°C) or lower). Also, it may exceed the processing ability when the amount of oil smoke generated during cooking is high.
There is a sour odor	<ul style="list-style-type: none"> ● Depending on the food, a sour odor may occur during cooking, but this is caused by the catalyst reaction and it is not abnormal.
Foods “explode” during heating	<ul style="list-style-type: none"> ● Microwave power level is too high. Reduce power level. ● Skins of foods i.e potatoes, chicken are not pierced. Pierce skins on foods to release pressure build up during heating. NEVER try to boil eggs in shells.
Smoke appears around the door when grilling	<ul style="list-style-type: none"> ● Fat from food is splashing on to the grill elements and burning. Stop the oven and drain away all excess fat and juices. Watch the food carefully as it grills. Ensure the cavity ceiling and all accessories are cleaned regularly.

Troubleshooting

Symptom	Cause
The cooking result of a certain memory cooking is different from that of the previous time	<ul style="list-style-type: none"> Did the preheat temperature or cooking mode that were set into memory change? (p.25)

Common Queries

Question	Answer
Where can I obtain additional oven accessories?	<ul style="list-style-type: none"> Contact the manufacturer or the dealer from whom you purchased the oven.
Can the oven be stacked?	<ul style="list-style-type: none"> Only the same oven can be stacked. Be sure to fix with optional parts. For details, refer to "Instruction for Stacking". (p.9)
Can I dry tea towels and clothes in the oven?	<ul style="list-style-type: none"> No. Never put these, or similar items, in your Panasonic Oven.
How often should the oven be serviced?	<ul style="list-style-type: none"> When the message referring p.46 is displayed, oven maintenance is required. Please contact the dealer or a service agent. (p.3) Continuing to use the oven may cause failure.

When to Call a Service Agent

If a "U" or "F" Appears In The Display

Start all over again after checking the contents when the following display appears. Display disappears when Stop/Reset pad is pressed.

Display	Cause
U16	<p>The SD Memory Card is locked.</p> <ul style="list-style-type: none"> Insert the SD Memory Card again after releasing the lock. (p.51) 
U17	<p>A card other than the specified SD Memory Card is inserted.</p> <ul style="list-style-type: none"> Take out the SD Memory Card and check. (p.51) <p>If the "U17" appears even after inserting the specified SD Memory Card, the SD Memory Card may be damaged.</p>
U19	<p>The SD Memory Card is not inserted.</p> <ul style="list-style-type: none"> Please insert the specified SD Memory Card. (p.51)
U41 or U43	<p>Grounding is incomplete.</p> <ul style="list-style-type: none"> Contact the dealer or a service agent. (p.3)
U88	<p>The touch screen is touched for a while.</p> <ul style="list-style-type: none"> Has the screen been touched for 25 seconds or more? Is there any dirt stuck on the screen?
F09	<p>The oven is connected to 50 Hz. Connect to 60 Hz.</p>
F code other than F09 (F97, etc.)	<p>If the "F" code does not disappear even after pressing the Stop/Reset pad, pull out the plug and then plug it in again after 5 seconds. The oven is faulty if the "F" code still appears. Unplug the oven or shut off the power at the circuit breaker, and contact the dealer or a service agent. (p.3)</p>

When to Call a Service Agent

If There Is Damage To The Oven

Contact a service agent immediately if you find damage to the supply cord, control panel, cavity, accessories, or the door. It is best not to use the oven again until you have ascertained from the service agent that it is safe to do so. Remember to give the service agent as much information as possible. (p.3)

If The Oven Is Not Working

If you find the oven is not working, follow these points before contacting a service agent.

Check:

1. The oven door is closed.
2. The required function(s) have been set correctly and the Start pad pressed. (pp.28–41)
3. The program lock has not been activated or deactivated against your requirements.
4. The oven is connected to a 20 amp outlet and the supply is operational. Try another power point, there maybe a problem with the outlet or even a total power failure.
5. The oven is not connected to the electrical supply by means of an adaptor or extension cable.
6. The air vents are not blocked. If they are, unblock them, leave the oven for 15 minutes and then try again.
7. The “Troubleshooting” and “Common Queries” section on pp.47–48.

If the oven is still not operational, contact your service agent with all your details. (p.3)

SD Memory Card

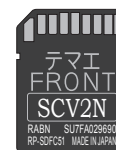

Specified SD Memory Card

- Set in the main unit when shipped from the factory.
- When saving or deleting a cooking process, or when cooking according to a saved program, be sure to set up and use the specified SD Memory Card. If a card other than the specified SD Memory Card is set up, “U17” appears. (p.49)
- You can also save a cooking program data onto the specified SD Memory Card using your personal computer. (pp.52–53)

Notes

- Be careful not to impart static electricity to the SD Memory Card while it is not set in the main unit.
- Do not dismantle or modify.
- Do not bend, drop, wet or subject the SD Memory Card to strong impacts.
- Do not touch the metal terminals with your hands or metal.
- Do not peel off the pasted labels. Also, do not paste new labels or stickers.
- Do not expose to direct sunlight or place in other hot locations.
- Do not place in humid or dusty locations.
- Do not place in locations where corrosive and other gases are generated.
- Always close the SD Memory Card cover except when inserting and taking out the card to prevent contamination by water and dirt.
- If the SD Memory Card is lost or becomes faulty, please contact the dealer or a service agent to obtain a replacement. (p.3)

How to insert/remove

- Before you insert / remove an SD Memory Card, always unplug the oven for personal safety. Insert and remove the SD Memory Card with the display unit turned off. Data may be destroyed when it is inserted or removed immediately after the power supply plug is inserted or when the display unit is turned on.

How to remove

- ① Remove the front cover

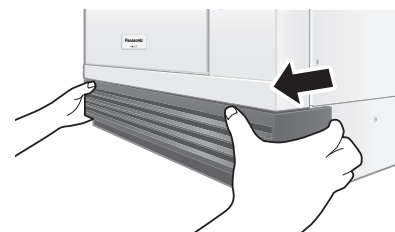

- ② Turn the screw and open the SD Memory Card cover by tools

SD Memory Card Cover Screw

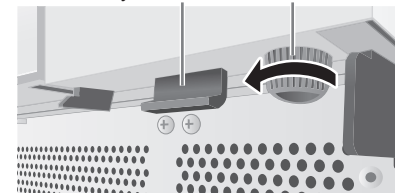

- ③ Push in the SD Memory Card with your finger
Take out the SD Memory Card when it comes out.

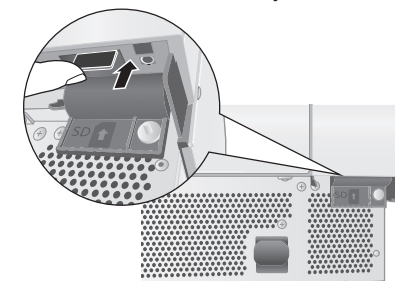

How to insert

- ① Insert the SD Memory Card all the way inside

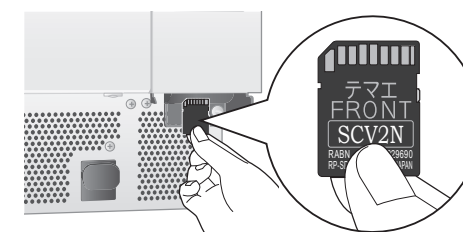

- ② Close the SD Memory Card cover and tighten the screw by tools

SD Memory Card Cover Screw

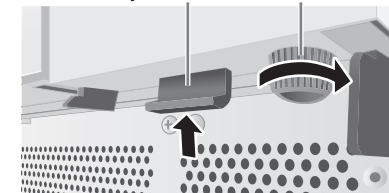

- ③ Attach the front cover
Install the main unit (A) into the groove of the drip tray.

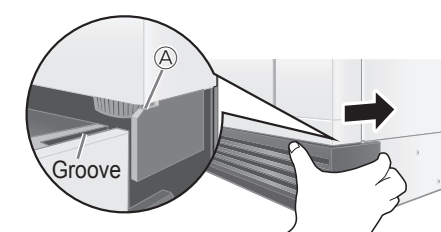

SD Memory Card

Saving a Cooking Program on SD Memory Card

You can save a cooking program data onto the specified SD Memory Card using your personal computer.

⚠ WARNING

1. It is prohibited to copy the data on an SD Memory Card for business purposes or reproduce it on a website.
2. The "SD" logo is a trademark.
3. Microsoft Windows is a trademark of Microsoft Corporation, U.S.A.
4. The other various designations, brand names, etc. are the registered trademarks of their respective companies.
5. The names of oven you use may be different from those used in this booklet. Windows, messages, etc. used in this booklet may be different from those on your personal computer depending on the environment (OS versions, etc.). Carefully read the instructions for your personal computer for how to use it.
6. Editing the data directly on the SD Memory Card without copying it to your personal computer may not work properly depending on your environment.
7. Our company assumes no responsibility whatsoever for damage of the data on the SD Memory Card.

⚠ CAUTION

1. It is recommended to use SD Memory Cards with Microsoft Windows 7, Microsoft Excel 2010, or later.
2. Unlock the SD Memory Card otherwise the program data cannot be stored.

How to Save a Cooking Program on SD Memory Card using your personal computer *As of December 2018

■ Preparing pictures

- ① Turn on your personal computer and activate Windows.
- ② Save desired pictures in an appropriate folder on your personal computer.
 - The recommended size of the image is VGA 640 × 480. When using images other than this size, images may be overlooked or rough.
 - Do not use spaces or symbols for the user names or folder names, etc.

■ Inserting the specified SD Memory Card

- ③ Inserting the specified SD Memory Card into the SD card reader on your personal computer.
- ④ Double-click the SD Memory Card drive in "My Computer" folder.
- ⑤ Move "meigroup" folder to your personal computer such as Desktop. Avoid moving the folder to a deeper layer of your personal computer.

■ Rewriting the program in your personal computer

- ⑥ Double-click "meigroup" folder. Double-click "NE-SCV2NAPR" folder. DO NOT TOUCH other files and folders.
- ⑦ Open "NE_SCV2NAPR_MemoryCookingData.xlsx". If "Enable Content" is displayed, click it. Please input the below data (at least "Preheat Temp" and "Step 1" data is necessary.)
 - Dish Name
 - Picture File
 - pcs.
 - Preheat Temp
 - Step 1 data
 - Turn back buzzer

⑦-1 How to select Picture file

Click "Picture File" cell for a desired Memory Number, then select a picture. Please note that only "jpg" data is acceptable.

⑦-2 How to input cooking data

Click the "Function" cell for Step 1, and the drop-down menu will appear. Select a cooking function from the drop-down list.

- GR: Grill
- CV: Convection
- GR+CV: Grill and Convection
- MW+GR: Microwave and Grill
- MW+CV: Microwave and Convection
- MW: Microwave (You cannot use at Step 1.)

Once you select Function, options will appear in yellow. Select options from the drop-down menus. Enter the data for each cooking step.

⑧ When all the program data has been entered, click "Save Data" in the upper right. (It is not "Overwrite" of Excel file.)

Click "OK" when done.

⑨ Record Checksum 4-digit number for verification.

Overwrite and close "NE_SCV2NAPR_MemoryCookingData.xlsx".

- If it is not operational, contact the dealer or a service agent. (p.3)

■ Updating the data on the SD Memory Card

- ⑩ Copy "meigroup" folder of your personal computer such as Desktop to "meigroup" folder on the SD Memory Card to overwrite.

How to verify the data (SD Checksum)

- ① Insert the specified SD Memory Card to the oven.
- ② Follow steps as instructed in p.27 and verify the 4-digit number is same with the one you recorded in step ⑨ above.

How to delete the program data

- ① Follow steps ① to ⑥ in p.52.
- ② Click "Data Clear".
- ③ The confirmation screen is displayed. Click "Yes". The program data will be all deleted.

SD-USB Adapter

Only use the included SD Memory Card.

● Compatible OSes

Windows 7 (32-bit/64-bit)
Windows 8 (32-bit/64-bit)
Windows 8.1 (32-bit/64-bit)
Windows 10 (32-bit/64-bit)
Mac OS X 10.8 or later

Specifications

Power Source		208/240 V AC, 60 Hz, Single phase
Required Power		3750 W 19 A (208 V) 17 A (240 V)
Receptacle Required		20 A (NEMA #6-20R)
Output	Microwave	1200 W (IEC 60705)
	Convection	1265 W
	Grill	1915 W
Frequency		2450 MHz
Convection Temperature Range		350–525 °F (180–280 °C)
Preheating Temperature Range		475 °F (250 °C) / 525 °F (280 °C) (Default) Can be changed between 350–525 °F (180–280 °C) in 25 °F increments
Net Weight		Approx. 83.8 lbs. (38.0 kg) (including accessories)
Outer Dimensions (W×D×H)		18- ¹¹ / ₁₆ "×22- ¹ / ₄ "×16- ⁷ / ₃₂ " (474 mm×565 mm×412 mm)
Cavity Dimensions (W×D×H)		10- ⁵ / ₈ "×13"×4- ⁵ / ₁₆ " (270 mm×330 mm×110 mm)

Specifications subject to change without notice.

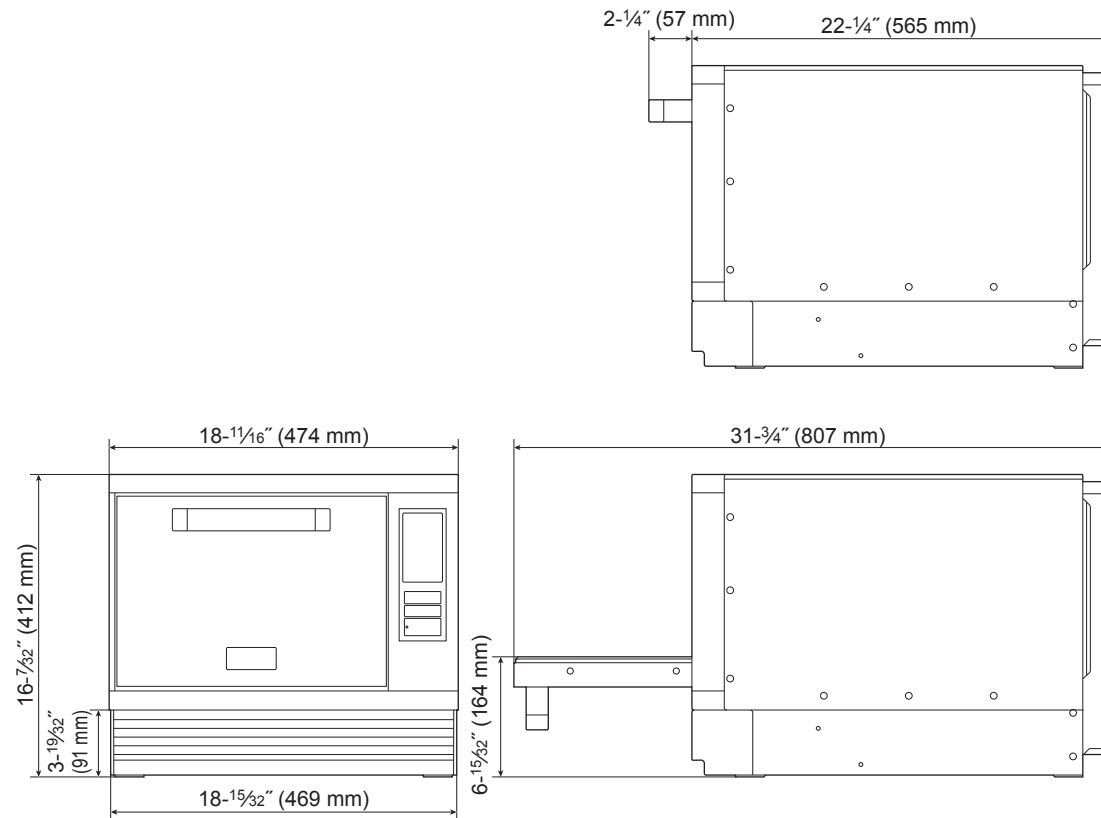

www.us.panasonic.com/cmo

Panasonic Corporation of North America

Two Riverfront Plaza,
Newark, NJ 07102-5490

For Parts and Service:

1-877-266-6836

For Sales, Test Kitchen and Technical Support:

1-877-266-6836 (1-877-CMO-OVEN)

© Panasonic Corporation 2018

A05063G80AP

F1118-0

Printed in Japan