

Panasonic®

Owner's Manual Compact Stereo System

Model No. SC-HC55
SC-HC35

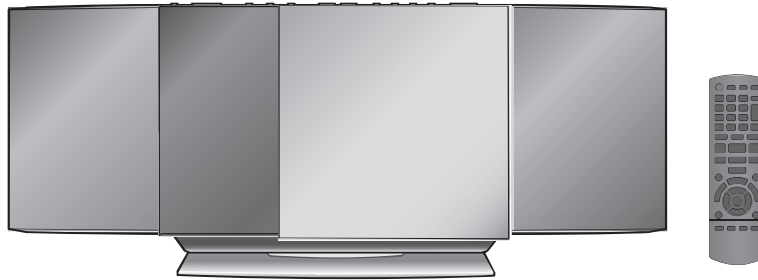

Dear customer

Thank you for purchasing this product.
For optimum performance and safety, please read these instructions carefully.
Please keep this manual for future reference.

If you have any questions contact
U.S.A. and Puerto Rico: 1-800-211-PANA (7262)
Canada: 1-800-561-5505

Only for U.S.A. and Puerto Rico: The warranty can be found on page 26
Only for Canada: The warranty can be found on page 27

Included Installation Instructions (⇒ 2, 6)

The installation should never be done by any other than a qualified installation specialist.
Before commencing work, carefully read these installation instructions and the operating instructions to ensure that installation is performed correctly.
(Please keep these instructions. You may need them when maintaining or moving this unit.)

La referencia rápida en español se puede encontrar en la página 18-24.

P PC

RQTX1260-P

Confidential until
2011/02/28

IMPORTANT SAFETY INSTRUCTIONS

Read these operating instructions carefully before using the unit. Follow the safety instructions on the unit and the applicable safety instructions listed below. Keep these operating instructions handy for future reference.

- 1 Read these instructions.
- 2 Keep these instructions.
- 3 Heed all warnings.
- 4 Follow all instructions.
- 5 Do not use this apparatus near water.
- 6 Clean only with dry cloth.
- 7 Do not block any ventilation openings. Install in accordance with the manufacturer's instructions.
- 8 Do not install near any heat sources such as radiators, heat registers, stoves, or other apparatus (including amplifiers) that produce heat.
- 9 Do not defeat the safety purpose of the polarized or grounding-type plug. A polarized plug has two blades with one wider than the other. A grounding-type plug has two blades and a third grounding prong. The wide blade or the third prong are provided for your safety. If the provided plug does not fit into your outlet, consult an electrician for replacement of the obsolete outlet.
- 10 Protect the power cord from being walked on or pinched particularly at plugs, convenience receptacles, and the point where they exit from the apparatus.
- 11 Only use attachments/accessories specified by the manufacturer.
- 12 Use only with the cart, stand, tripod, bracket, or table specified by the manufacturer, or sold with the apparatus. When a cart is used, use caution when moving the cart/apparatus combination to avoid injury from tip-over.
- 13 Unplug this apparatus during lightning storms or when unused for long periods of time.
- 14 Refer all servicing to qualified service personnel. Servicing is required when the apparatus has been damaged in any way, such as power-supply cord or plug is damaged, liquid has been spilled or objects have fallen into the apparatus, the apparatus has been exposed to rain or moisture, does not operate normally, or has been dropped.



Batteries

- Danger of explosion if battery is incorrectly replaced. Replace only with the type recommended by the manufacturer.
- Mishandling of batteries can cause electrolyte leakage and may cause a fire.
 - Do not heat or expose to flame.
 - Do not leave the battery(ies) in a car exposed to direct sunlight for a long period of time with doors and windows closed.
 - Do not take apart or short circuit.
 - Do not recharge alkaline or manganese batteries.
 - Do not use batteries if the covering has been peeled off.
 - Remove batteries if you do not intend to use the remote control for a long period of time. Store in a cool, dark place.
- When disposing the batteries, please contact your local authorities or dealer and ask for the correct method of disposal.

WARNING

Unit

- To reduce the risk of fire, electric shock or product damage,
 - Do not expose this unit to rain, moisture, dripping or splashing.
 - Do not place objects filled with liquids, such as vases, on this unit.
 - Use only the recommended accessories.
 - Do not remove covers.
 - Do not repair this unit by yourself. Refer servicing to qualified service personnel.

Power cord

- Install this unit so that the power cord can be unplugged from the socket outlet immediately if any problem occurs.

CAUTION

Unit

- This unit utilizes a laser. Use of controls or adjustments or performance of procedures other than those specified herein may result in hazardous radiation exposure.
- Do not place sources of naked flames, such as lighted candles, on this unit.

Placement

- To reduce the risk of fire, electric shock or product damage,
 - Do not install or place this unit in a bookcase, built-in cabinet or in another confined space. Ensure this unit is well ventilated.
 - Do not obstruct this unit's ventilation openings with newspapers, tablecloths, curtains, and similar items.

CAUTION

**RISK OF ELECTRIC SHOCK
DO NOT OPEN**

CAUTION: TO REDUCE THE RISK OF ELECTRIC SHOCK, DO NOT REMOVE SCREWS. NO USER-SERVICEABLE PARTS INSIDE. REFER SERVICING TO QUALIFIED SERVICE PERSONNEL.

The lightning flash with arrowhead symbol, within an equilateral triangle, is intended to alert the user to the presence of uninsulated "dangerous voltage" within the product's enclosure that may be of sufficient magnitude to constitute a risk of electric shock to persons.

The exclamation point within an equilateral triangle is intended to alert the user to the presence of important operating and maintenance (servicing) instructions in the literature accompanying the appliance.

The model number and serial number of this product can be found on either the back or the bottom of the unit. Please note them in the space provided below and keep for future reference.

MODEL NUMBER _____

SERIAL NUMBER _____

User memo:

DATE OF PURCHASE _____

DEALER NAME _____

DEALER ADDRESS _____

TELEPHONE NUMBER _____

CAUTION -	NEVER AVOID EYE LASER RADIATION WHEN OPEN < and INTERLOCKS OPERATED >. DO NOT STARE INTO BEAM. (FDA # CD14 1111a)
CAUTION -	CLASS 1M EYE AND VISIBLE LASER RADIATION WHEN OPEN < and INTERLOCKS DEACTED >. DO NOT STARE INTO BEAM. (FDA # CD14 1111a)
ATTENTION -	PROHIBITED LASER RADIATION CLASS 1M LASER PRODUCT. (FDA # CD14 1111a)
WARNING -	CLASS 1M LASER RADIATION. LASER STRAHLUNG NUR BEI OFFENEM LASERKOPF. (FDA # CD14 1111a)
FORNITIG -	SYMBOLI LASERSTRÅLING KLASSE 1M. LASERSTRÅLING ENKASTET. (FDA # CD14 1111a)
VAROITUS -	VAIKATTUSSA LASERVALON SÄTEETÄSSÄ KÄYTTÖNÄ LUOKAN 1M LASERIN. (FDA # CD14 1111a)
VOORSICHT -	VERBODEN LASERSTRALING KLASSE 1M. LASERSTRALING VERBODEN. (FDA # CD14 1111a)
PRECAUTION -	PROHIBIT USER SERVICEABLE PARTS. CLASS 1M LASER RADIATION. (FDA # CD14 1111a)
注意 -	本機はレーザー放射線が危険な場合があります。レーザー光線に目を注ぐことは危険です。 (RQTX1260)

(Inside of product)

Listening Caution

Selecting fine audio equipment such as the unit you've just purchased is only the start of your musical enjoyment. Now it's time to consider how you can maximize the fun and excitement your equipment offers. This manufacturer and the Electronic Industries Association's Consumer Electronics Group want you to get the most out of your equipment by playing it at a safe level. One that lets the sound come through loud and clear without annoying blaring or distortion—and, most importantly, without affecting your sensitive hearing.

We recommend that you avoid prolonged exposure to excessive noise.

Sound can be deceiving. Over time your hearing "comfort level" adapts to higher volumes of sound. So what sounds "normal" can actually be loud and harmful to your hearing. Guard against this by setting your equipment at a safe level BEFORE your hearing adapts.

To establish a safe level:

- Start your volume control at a low setting.
- Slowly increase the sound until you can hear it comfortably and clearly, and without distortion.

Once you have established a comfortable sound level:

- Leave it there.

Taking a minute to do this now will help to prevent hearing damage or loss in the future. After all, we want you listening for a lifetime.

Product Identification Marking is located on bottom of the unit.

Made for

"Made for iPod" and "Made for iPhone" mean that an electronic accessory has been designed to connect specifically to iPod, or iPhone, respectively, and has been certified by the developer to meet Apple performance standards. Apple is not responsible for the operation of this device or its compliance with safety and regulatory standards. Please note that the use of this accessory with iPod, or iPhone may affect wireless performance. iPhone, iPod, iPod classic, iPod nano, and iPod touch are trademarks of Apple Inc., registered in the U.S. and other countries.

The Bluetooth word mark and logos are owned by the Bluetooth SIG, Inc. and any use of such marks by Panasonic Corporation is under license. Other trademarks and trade names are those of their respective owners.

MPEG Layer-3 audio coding technology licensed from Fraunhofer IIS and Thomson.

-If you see this symbol-

Information on Disposal in other Countries outside the European Union

This symbol is only valid in the European Union. If you wish to discard this product, please contact your local authorities or dealer and ask for the correct method of disposal.

About descriptions in this Owner's Manual

- Operations in these instructions are described using remote control, but you can do the operations with the main unit if the controls are the same. Your unit may not look exactly as illustrated.
- This Owner's Manual is applicable to models SC-HC55 and SC-HC35. Unless otherwise indicated, illustrations in this Owner's Manual are of SC-HC55.
- **HC55** : indicates features applicable to SC-HC55 only.
- **HC35** : indicates features applicable to SC-HC35 only.
- Pages to be referred to are indicated as "⇒ ○○".
- **CD** : indicates CD-DA (except MP3).
- **MP3** : indicates MP3 files.

Accessories

Check the supplied accessories before using this unit.

- 1 Remote control**
(HC55 N2QAYB000643)
(HC35 N2QAYB000641)
- 1 AM loop antenna**
(N1DY00010)
- 1 FM indoor antenna**
(RSAX0002)
- 1 AC power supply cord**
(K2CB2CB00021)
- 1 Battery for remote control**

Wall mounting accessories

- 2 Safety holder screws** (XYN4+8FJK)
- 2 Safety holders** (RGQ0634-K)
- 2 Wall mount brackets** (RMQX1082-K)
- 2 Rear pads** (RKA0252-K)

(ONLY FOR CANADA)

The enclosed Canadian French label sheet corresponds to the English display on the top of the unit.



- Product numbers correct as of January 2011. These may be subject to change.
- Do not use AC power supply cord with other equipment.
- Only for U.S.A. and Puerto Rico:
To order accessories, refer to "Accessory Purchases (United States and Puerto Rico)" on page 26.
For Canada: To order accessories, call the dealer from whom you made your purchase.

■ The remote control information

Insert so the poles (+ and -) match those in the remote control.

Place this side in before the other side.

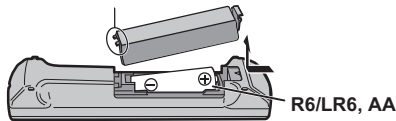

- Use alkaline or manganese batteries.

Table of contents

IMPORTANT SAFETY INSTRUCTIONS	2
Listening Caution.....	3
Accessories.....	4
Unit and media care.....	4
Connections.....	5
Attaching the unit to a wall (optional).....	6
Control reference guide.....	8
Opening/Closing the sliding door.....	9
Disc operations.....	9
Sound adjustment.....	10
Radio operations.....	11
Timer.....	11
Listening to audio from iPod or iPhone.....	12
HC55 Using a Bluetooth compatible device.....	13
Others.....	15
Troubleshooting.....	15
Specifications.....	17

Spanish Quick Reference/ Referencia rápida en español

Conexiones.....	18
Guía de referencia del mando a distancia.....	19
Abrir/Cerrar la puerta deslizante.....	20
Operaciones con discos.....	20
Operaciones con la radio.....	21
Ajuste de sonido.....	22
Sincronizador.....	22
Escuchar audio de un iPod o iPhone.....	23
HC55 Uso de un dispositivo compatible con Bluetooth.....	24

Limited Warranty (ONLY FOR U.S.A. AND PUERTO RICO).....	26
Limited Warranty (ONLY FOR CANADA).....	27

Unit and media care

Pull out the AC power plug from the outlet before maintenance.

■ Clean this unit with a soft, dry cloth

- Never use alcohol, paint thinner or benzine to clean this unit.
- Before using chemically treated cloth, carefully read the instructions that came with the cloth.
- When dirt is heavy, wring the cloth moistened in water tightly to wipe the dirt, and then wipe it with a dried cloth.
- Do not use tissues or other materials that can fall apart. Small grains may get stuck inside the speaker cover.

■ Maintenance of the lens

- Clean the lens regularly to prevent malfunctions. Use a blower to remove dust and a cotton swab if it is extremely dirty.
- You cannot use a CD type lens cleaner.
- Do not leave the sliding door open for prolonged periods of time. This will cause the lens to get dirty.
- Be careful not to touch the lens with your fingers.

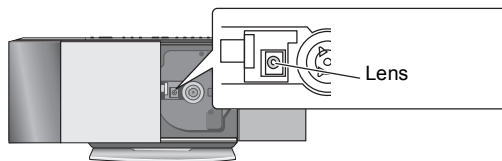

■ Clean discs

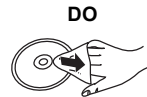

Wipe with a damp cloth and then wipe dry.

■ Disc handling precautions

- Handle discs by the edges to avoid inadvertent scratches or fingerprints on the disc.
- Do not attach labels or stickers to discs.
- Do not use record cleaning sprays, benzine, thinner, static electricity prevention liquids or any other solvent.
- Do not use the following discs:
 - Discs with exposed adhesive from removed stickers or labels (rented discs etc.).
 - Discs that are badly warped or cracked.
 - Irregularly shaped discs, such as heart shapes.

Connections

Notes on speakers

- These speakers do not have magnetic shielding. Do not place them near a television, personal computer or other devices easily influenced by magnetism.

Back View

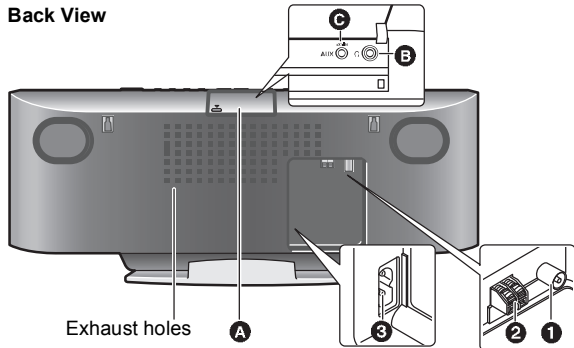

Additional Connections

Open the EXT-IN AUX/Headphone cover to connect headphones or external music devices (e.g. MP3 player).
Push the projecting part to open the cover A.
Top View

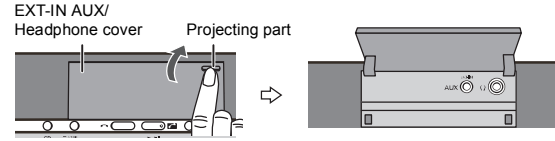

Connect the headphones (not supplied)

Reduce the volume level and connect the headphones.

Plug type: $\varnothing 3.5$ mm (1/8") stereo B



- To prevent hearing damage, avoid listening for prolonged periods of time. Excessive sound pressure from earphones and headphones cause hearing loss.

Connect an external music device (for AUX mode)

① Plug the audio cable (not supplied) into the EXT-IN AUX jack C.

Plug type: $\varnothing 3.5$ mm (1/8") stereo

② Press [EXT-IN, RADIO] repeatedly to select "AUX" and start playback on the connected device.

EXT-IN



You can select the sound input level of the external device.

HC55 ① Press [SOUND] repeatedly to select "INPUT LEVEL".

② Press [◀, ▶] to select "HIGH" or "NORMAL".

HC35 Press [INPUT LEVEL] repeatedly to select "HIGH" or "NORMAL".

- Switch the equalizer off or turn the volume of the external device down to reduce the input signal. High level of input signal will distort the sound.
- For details, refer to the instruction manual of the other equipment.
- Cables and devices are not supplied.

Basic Connections

1 Connect the FM indoor antenna.

- Tape the antenna to a wall or column, in a position with the least amount of interference.

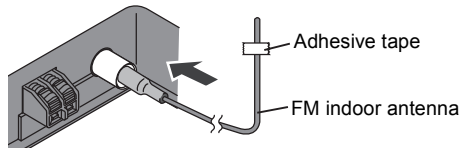

2 Connect the AM loop antenna.

- Keep the loop antenna cord away from other wires and cords.

A Stand the antenna up on its base until it clicks.

B AM loop antenna

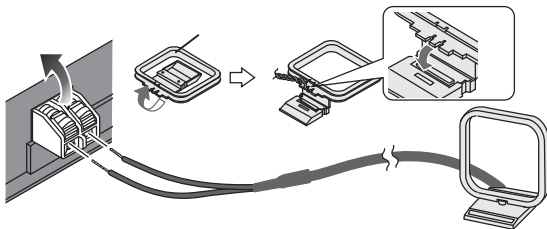

3 Connect the AC power supply cord.

Connect the AC power supply cord after all other connections are complete.

Turn the unit on after a few seconds.

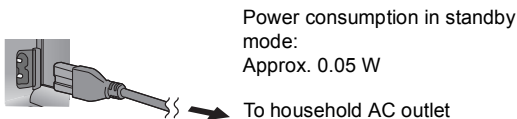

Attaching the unit to a wall (optional)

Installation accessories

■ Supplied accessories

- 2 Safety holder screws **B**
- 2 Safety holders
- 2 Wall mount brackets
- 2 Rear pads

■ Commercially available accessories (not supplied)

- 4 Wall bracket fixing screws **C**

- Keep the wall mount brackets out of reach of children to prevent swallowing.
- Keep the rear pads out of reach of children to prevent swallowing.
- Keep the screws out of reach of children to prevent swallowing.
- Keep the safety holder out of reach of children to prevent swallowing.



- Use screws with a nominal diameter of $\varnothing 4$ mm ($5/32$ "), which are suitable to the material of the wall (e.g., wood, steel, concrete, etc.)

Safety precautions

WARNING!

- Only a qualified building contractor shall install or uninstall this unit.
 - Improper installation may cause the unit to fall, resulting in injury.
- To prevent injury, the unit must be securely attached to the wall in accordance with the installation instructions.
- Do not install the unit where it cannot support the load.
 - If the mounting parts are not strong enough, this may cause the unit to fall, resulting in injury.
- Do not use installation methods other than instructed.
 - This may cause the unit to fall and be damaged, resulting in injury.
- Do not install the unit at locations other than vertical walls.
 - This may cause the unit to fall and be damaged, resulting in injury.
- Take the safety factor for mounting strength into account (approx. 10 times the product weight).
 - Insufficient strength will cause the unit to fall, resulting in injury.
- The wall on which the unit is to be attached to should be capable of supporting 20 kg (44 lbs) per screw.
 - Insufficient strength of the walls will cause the unit to fall in the long run.
- Do not disassemble or modify the wall-mounting hanger.
 - This will cause the unit to fall and be damaged, resulting in injury.

CAUTIONS!

- Do not install this unit at humid or dusty locations, or locations where airborne grease or steam may come into contact with the unit, or under an air conditioner where water may drip onto the unit.
 - This may have negative impact on the unit, resulting in fire or electric shock.
- Secure enough space of more than 30 cm (11 $3/16$ ") above the main unit and more than 10 cm (3 $9/16$ ") on the left and right sides respectively. Keep space between the wall and rear of the unit clear of obstructions.
 - Blocking the exhaust holes on the main unit may result in fire.
- Use the designated components for installation.
 - Otherwise, the main unit may fall and be damaged, resulting in injury.
- Prevent the mounting screws or power cord from coming into contact with metal parts inside the wall during installation.
 - Failure to do so may cause electric shock.
- When removing the main unit, remove the wall mounting screws as well.
 - Otherwise the wall mounting screws may hit a person and lead to injury.
- Install the unit at a height where the EXT-IN AUX jack and operation buttons can be seen for safe operation.
 - Operating at improper position may cause the unit to fall and be damaged, resulting in injury.

■ Notes on installation

- Before installation, read the "Safety precautions" and "Wall mount instructions" for correct installation.
- For optimal performance and to prevent potential problems, do not install this unit:
 - at locations other than vertical walls.
 - near a sprinkler or a sensor.
 - near high-voltage lines or power sources.
 - near heating device.
 - at locations where the unit is subject to vibration or impact.
 - near sources of magnetism, heat, vapor, airborne grease, etc.
 - at locations where there may be water droplets (e.g. under an air conditioner).
- Do not install this unit under ceiling lights (e.g. spotlight, halogen light, etc.).
 - Failure to do so may bend the cabinet or lead to damage caused by high heat.
- Use a proper installation method that suits the structure and material of the wall.
- Use a soft blanket or cloth to prevent damage to the product or floor during installation.
- When tightening screws, make sure the screws are not loosely-tightened or overtightened.
- Secure a safe surrounding area and pay attention to safety during installation.
- Panasonic is not liable for incidental or consequential damages resulting from improper installation or operation.

Wall mount instructions

- Before installation, turn the unit off and disconnect the AC power supply cord from the AC outlet.

1 Detach the stand from the unit.

- ① Unscrew the fixing screw **A** (4 pieces) at the bottom of the unit.

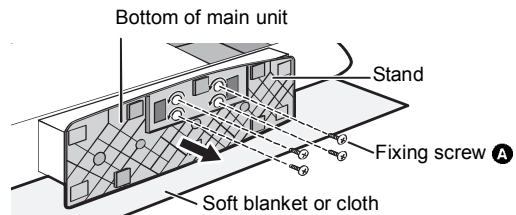

- ② Gently pull the bottom of the stand and slide the stand off the unit.

- Keep the removed screws and stand in a safe place.

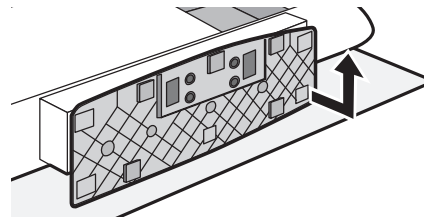

2 Measure and mark the position of the wall mount brackets (Both sides).

- Use figures below to identify the screwing positions.

The position to attach the wall mount brackets

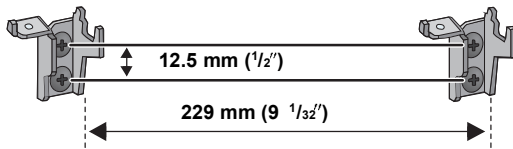

Space required

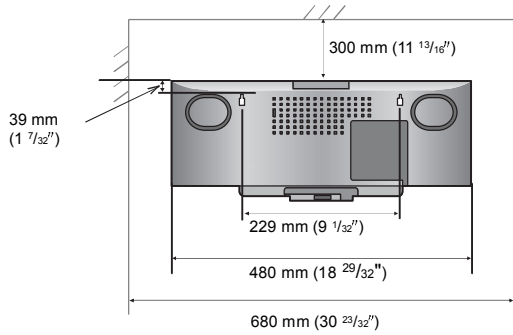

3 Attach the wall mount bracket to the wall with 2 screws (Both sides)

- Use a spirit level to ensure both wall mount brackets are level.
- Use a screw which is strong enough to support the weight of at least 20 kg (44.1 lbs).

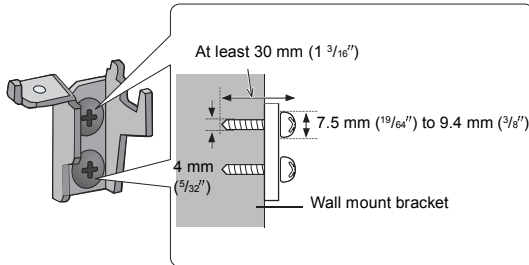

4 Hang the unit on the wall.

Hook the unit securely onto the wall mount brackets.

- Connect the FM/AM antenna and the AC power supply cord to the unit before hanging the unit onto the wall. (→ 5)
- After hanging the unit, release your hand carefully to confirm the unit sits securely on the wall.
- Before attaching, stick the rear pads (supplied) to (A).

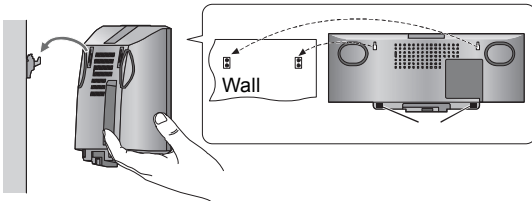

5 Fix the safety holders onto the wall mount brackets with the safety holder screws (B).

- Screw tightening torque: 80 N•cm (17.98 lbf-ft) to 120 N•cm (26.98 lbf-ft).

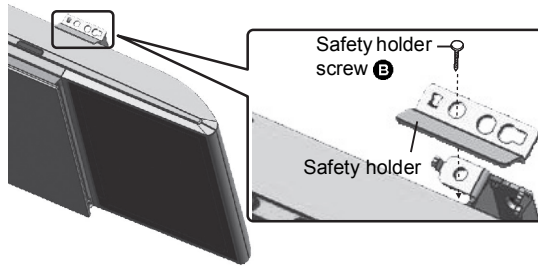

■ Fall-prevention measure (optional)

This measure is only designed as a backup feature to prevent the unit from falling.

This will not guarantee that the unit will not fall or get damaged.

- ① Thread a cord (not supplied) through the 2 holes in the safety holder before step 5.
- ② Fix the cord to the wall with a screw (not supplied) after step 5.

- Fix the cord to the screw so that a slack of no more than 5 cm (1 3/16 inches) is kept.

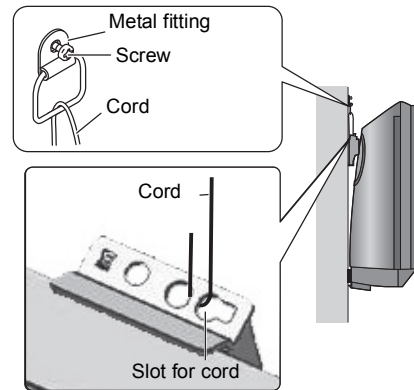

Control reference guide

Remote control

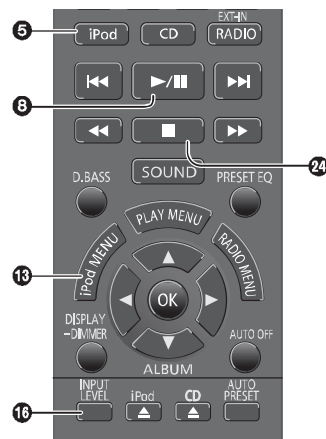
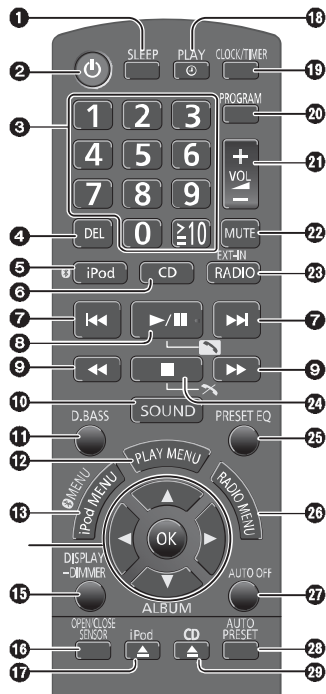

Front view

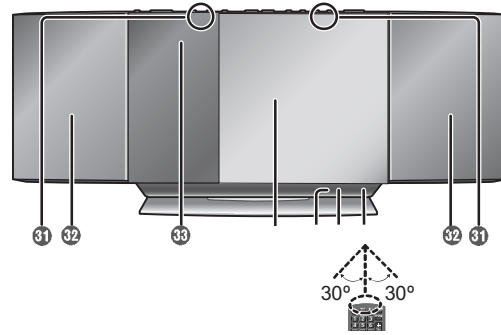

- 1 [SLEEP] (⇨ 11)
- 2 Standby/on switch [⏻], [POWER, ⏻/⏪] (⇨ 9, 11, 15)
- 3 Numeric buttons [1-9, 0, ≧10] (⇨ 9, 10, 11, 15)
To select a 2-digit number
e.g. 16: [≧10] → [1] → [6]
To select a 3-digit number
e.g. 226: [≧10] → [≧10] → [2] → [2] → [6]
- 4 [DEL] (⇨ 10)
- 5 HC55 [⏻], iPod (⇨ 12, 13)
- 6 HC35 [iPod] (⇨ 12)
- 7 [CD] (⇨ 9)
- 8 [◀▶], [▶▶] (⇨ 9, 10, 11, 12, 13)
- 9 [▶/||] (⇨ 9, 10, 12, 13)
- 10 HC55 [↶] (⇨ 14)
- 11 [◀◀], [▶▶] (⇨ 9, 11, 12)
- 12 [SOUND] (⇨ 5, 9, 10)
- 13 [D.BASS] (⇨ 10)
- 14 [PLAY MENU] (⇨ 9, 10)
- 15 [iPod MENU] (⇨ 12)
- 16 HC55 [⊗ MENU] (⇨ 14)
- 17 [▲, ▼, ◀, ▶], [OK] (⇨ 5, 9, 10, 11, 12, 14)
- 18 [DISPLAY] (⇨ 9, 14)
- 19 [-DIMMER]
- 20 Press and hold to dim the display panel. Press and hold again to cancel.
- 21 HC55 [OPEN/CLOSE SENSOR] (⇨ 9)
- 22 HC35 [INPUT LEVEL] (⇨ 5)
- 23 [iPod ▲, OPEN/CLOSE] (⇨ 9)
- 24 HC55 Sensor activity indicator*
- 25 [PLAY, ⏻] (⇨ 11)
- 26 [CLOCK/TIMER] (⇨ 11)
- 27 [PROGRAM] (⇨ 10, 11)
- 28 [+ , VOL , -] (⇨ 14)
- 29 [- VOLUME +] (⇨ 14)
- 30 Adjusts sound volume.
- 31 [MUTE] (⇨ 14)
Mutes the sound. Press again to cancel. "MUTE" is also canceled when the volume is adjusted or the unit is turned off.
- 32 [EXT-IN, RADIO] (⇨ 11, 15)
- 33 [RADIO/EXT-IN] (⇨ 11, 15)
- 34 [■] (⇨ 9, 10, 12, 13)
- 35 HC55 [↯] (⇨ 14)
- 36 [PRESET EQ] (⇨ 10)
- 37 [RADIO MENU] (⇨ 11)
- 38 [AUTO OFF]
- 39 This function allows you to turn the unit off (except in radio mode) after the unit is left unused for about 30 minutes.
When the function is turned on, the "A.OFF" indicator light.
- 40 [AUTO PRESET] (⇨ 11)
- 41 [CD ▲] (⇨ 9)
- 42 [CD ▲, OPEN/CLOSE] (⇨ 9)
- 43 HC55 Sensor activity indicator*
- 44 Standby indicator
- 45 HC55 Open/Close sensor (⇨ 9)
- 46 Speaker
- 47 Display
- 48 Sliding door
- 49 HC55 Microphone (⇨ 14)
- 50 HC55 Bluetooth indicator (⇨ 13)
- 51 Remote control signal sensor
Distance:
Within approx. 7 m (23 ft) directly in front.

Main unit

Buttons such as 2 function the same as the remote control. They can be used interchangeably.

Top view

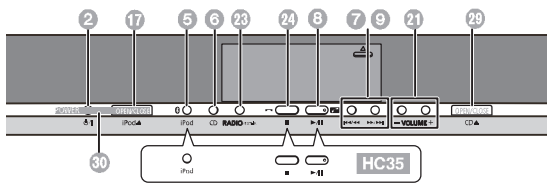

RQTX1260

* The sensor activity indicator will light when the Open/Close sensor is turned on.
One of the indicators will flash while the sliding door is opening or closing.

Opening/Closing the sliding door

Preparation

Press [⏻] to turn the unit on.

Opening the sliding door

For disc operations:

- Ⓐ While the sliding door is closed, press [CD ▲] to open the sliding door.

For iPod/iPhone operations:

- Ⓑ While the sliding door is closed, press [iPod ▲] to open the sliding door.

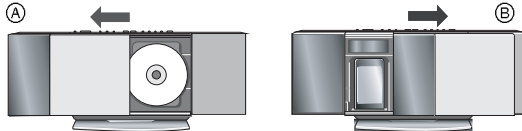

Closing the sliding door

Press [CD ▲] or [iPod ▲] again.

- Keep fingers away from the sliding door when it is closing to avoid possible minor injuries.



- Damage may occur if the sliding door is forced closed.
- Be careful of CD hitting the sliding door while being removed.
- The sliding door will not close if the docking switch lever is not returned to the original position.

HC55 Open/Close sensor

With this function the sliding door can be opened without pressing a button. The sliding door will open or close by moving your hand over the sensor.

For disc operations:

While the sliding door is closed, move your hand from Ⓑ to Ⓐ.

- To close the sliding door, move your hand from Ⓐ to Ⓑ.

For iPod/iPhone operations:

While the sliding door is closed, move your hand from Ⓐ to Ⓑ.

- To close the sliding door, move your hand from Ⓑ to Ⓐ.



To turn the Open/Close sensor off

Press [OPEN/CLOSE SENSOR].

- Each time the button is pressed, the sensor is turned on ("ON SENSOR") or off ("OFF SENSOR").

To add a sound effect when the sliding door opens/closes (when the sensor is used.)

- 1 Press [SOUND] repeatedly to select "BUZZER".
- 2 Press [◀] or [▶] to select the following setting.

LOW: Set the sound effect level to low.
MID: Set the sound effect level to medium.
HIGH: Set the sound effect level to high.
OFF: Turn the sound effect off.



- The open/close sensor might be unintentionally activated if an object, hand, part of your arm, pets or children move near the sensor.
- If the open/close sensor does not work or if the sensor's reaction range becomes smaller, open/close the sliding door using the buttons on the unit or the remote control.
- The disc operation side of the sliding door will not open during CD playback or pause.

Disc operations

Inserting a disc

- 1 Press [⏻] to turn the unit on.
- 2 Open the sliding door. (⇒ left)
- 3 With the label of the disc facing towards you, tilt the disc into the disc tray under the sliding door.
- 4 Place the disc onto the spindle in the center and then push the disc down until it clicks into place.
- 5 Close the sliding door. (⇒ left)

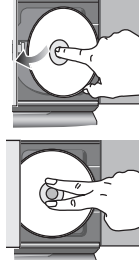

Removing a disc

- 1 Open the sliding door.
- 2 Hold the center and the top right of the disc and pull the top right of the disc to unlock it from the spindle.
- 3 Tilt the disc so as not to touch the sliding door or the lens and remove the disc.

Basic play

- 1 Press [⏻] to turn the unit on.
- 2 Insert the disc to be played (⇒ above).
- 3 Press [CD].
- 4 Press [▶/||] to start play.

Stop	Press [■].
Pause	Press [▶/]. Press again to resume play.
Skip	Press [◀◀] or [▶▶] to skip track. Press [▲, ▼] to skip album. (MP3)
Search CD	Press and hold [◀◀] or [▶▶].
Direct access play (Play starts from the track you selected.)	CD: Press the numeric buttons to select the track. MP3: ① Press [▲, ▼] to select the album. ② Press [▶▶] once and then the numeric buttons to select the track. • This function does not work during random play or program play. (⇒ 10)
View contents information	Press [DISPLAY] repeatedly during play or pause. The current track's information, etc. is displayed. • Maximum number of displayable characters: approximately 30 • This unit supports ver. 1.0, 1.1 and 2.3 ID3 tags. Text data that is not supported will not be displayed or shown differently.

Repeat play

After performing steps 1-3 in "Basic play" (⇒ above)

- 1 Press [PLAY MENU] repeatedly to select "REPEAT".
 - 2 Press [◀, ▶] to select "ON REPEAT" and press [OK].
 - 3 Press [▶/||] to start play.
- To stop repeat play, select "OFF REPEAT" in step 2.

Disc operations (Continued)

Play mode function

After performing steps 1-3 in "Basic play" (⇒ 9)

1 Press [PLAY MENU] repeatedly to select "PLAY MODE".

2 Press [◀, ▶] to select the following mode and press [OK].

1-TRACK <small>1TR:</small>	Plays one selected track on the disc.
1-ALBUM <small>1ALBUM:</small>	Plays one selected album on the disc. ● Press [▲, ▼] to select the album.
RANDOM <small>RND:</small>	Plays a disc randomly.
1-ALBUM RANDOM <small>1ALBUM RND:</small>	Plays all tracks in one selected album randomly. ● Press [▲, ▼] to select the album.

3 Press [▶/||] to start play.



- During random play, you cannot skip to the previous track.
- The current play mode is cleared when you open the sliding door.
- To repeat program play or selected play mode, select "ON REPEAT" in PLAY MENU. (⇒ 9)

Program play

Enables you to program up to 24 tracks.

After performing steps 1-3 in "Basic play" (⇒ 9)

1 Press [PROGRAM] during the stop mode.

2 [CD]:

Press the numeric buttons to select the track.

- To program more tracks, continue by pressing the numeric buttons.

[MP3]:

- ① Press [▲, ▼] to select the album.
- ② Press [▶▶] once and then the numeric buttons to select the track.
- ③ Press [OK].

To program more tracks, repeat steps ① - ③.

3 Press [▶/||] to start play.

Cancel program mode	Press [PROGRAM] in the stop mode to clear "PGM" indicator from the display.
Check program contents	Press [◀◀] or [▶▶] when "PGM" is displayed in the stop mode.
Delete last programmed track	Press [DEL] in the stop mode.
Clear all programmed tracks	① Press [■] in the stop mode. ② Press [■] again while blinking "CLR ALL".



- The program memory is cleared when you open the sliding door.

Notes on CD-R/CD-RW

- This unit can play CD-R and CD-RW recorded with CD-DA or MP3.
- Use an audio recording disc for CD-DA and finalize* it when you finish recording.
* A process performed after recording that enables CD-R or CD-RW players to play audio CD-R and CD-RW.
- The unit may not be able to play some discs due to the condition of the recording.
- Do not use irregularly shaped CDs.
- Do not attach extra labels and stickers.
- Do not use CDs with labels and stickers that are coming off or with excessive adhesive under the labels and stickers.
- Do not attach scratch-proof covers or any other kind of accessories.
- Do not write anything on the CDs.
- Do not clean CDs with liquids (Wipe with a soft and dried cloth).

Note about using a DualDisc

- The digital audio content side of a DualDisc does not meet the technical specifications of the Compact Disc Digital Audio (CD-DA) format so play may not be possible.
- Do not use a DualDisc in this unit as it may not be possible to insert it correctly and it may get scratched or scraped.

Creating MP3 files playable on this unit

- Maximum number of tracks and albums: 999 tracks and 254 albums (Excluding Root folder).
- Compatible compression rate: Between 64 kbps and 320 kbps (stereo). 128 kbps (stereo) is recommended.
- Disc formats: ISO9660 level 1 and level 2 (except for extended formats).
- The time for reading TOC depends on the number of the tracks, folders or folder structures.

Limitations on MP3

- This unit is compatible with multi-sessions and it takes more time to start playing.
- This unit cannot play files recorded using packet write.
- If the disc includes both MP3 and normal audio data (CD-DA), the unit plays the type recorded in the inner part of the disc. If the disc includes both MP3 and other types of audio data (e.g. WMA or WAV), the unit plays only the MP3.
- Depending on how you create the MP3 files, they may not play in the order you numbered them or may not play at all.

Sound adjustment

The following sound effects can be added to the audio output.

Preset EQ	Press [PRESET EQ] repeatedly to select "HEAVY", "SOFT", "CLEAR", "VOCAL" or "FLAT".
Bass or Treble	① Press [SOUND] repeatedly to select "BASS" or "TREBLE". ② Press [◀, ▶] to adjust the level (-4 to +4).
Surround Sound	① Press [SOUND] repeatedly to select "SURROUND". ② Press [◀, ▶] to select "ON SURROUND". ● To cancel surround sound, select "OFF SURROUND" in step ②. ● If interference in FM stereo reception increases, cancel the surround sound effect.
D.Bass	Press [D.BASS] during play to select "ON D.BASS" or "OFF D.BASS".

- You may experience a reduction in sound quality when these effects are used with some sources. If this occurs, turn the sound effects off.

Radio operations

Manual tuning

- 1 Press [EXT-IN, RADIO] repeatedly to select "FM" or "AM".
- 2 Press [◀◀] or [▶▶] to select the frequency of the required station.
 - "ST" is displayed when a stereo FM broadcast is being received.
 - To tune automatically, press and hold [◀◀] or [▶▶] until the frequency starts changing rapidly.
 - To cancel auto tuning, press [◀◀] or [▶▶] once again.
 - Auto tuning may not function when there is excessive interference.

To improve FM sound quality

- ① Press [RADIO MENU] while receiving FM broadcasts.
- ② Press [▲, ▼] to select "FM MODE".
- ③ Press [◀, ▶] to select "MONO".
 - Select "STEREO" in Step ③ to return to stereo broadcasts.
 - "MONO" is canceled if the frequency is changed.

To improve AM sound quality

- ① Press [RADIO MENU] to select "B.PROOF" while receiving AM broadcasts.
- ② Press [◀, ▶] to select the beat proof setting ("BP 1" or "BP 2") and press [OK].
 - This setting is reset to "BP 1" when changes are made (e.g. frequency is changed).

Memory preset

You can preset up to 30 FM channels and 15 AM channels.

Preparation

Press [EXT-IN, RADIO] repeatedly to select "FM" or "AM".

Automatic presetting

- ① Press [OK] to switch between the "LOWEST" and "CURRENT" frequency.
- ② Press [AUTO PRESET].
"PGM" starts to flash and the tuner starts to preset all the stations it can receive into the channels in ascending order.

Manual presetting

- ① Press [◀◀] or [▶▶] to tune to the required station.
- ② Press [PROGRAM].
- ③ While "PGM" is flashing, press the numeric buttons to select a channel.
 - The station occupying a channel is erased if another station is preset in that channel.
 - To preset more stations, repeat steps ① - ③.

Selecting a preset station

Press [◀◀] or [▶▶] to select the channel.

- Alternatively, press the numeric buttons to select the channel.

FM/AM frequency step

This unit is factory-set to FM 0.2 MHz and AM 10 kHz, but you can change it to receive broadcasts allocated in FM 0.1 MHz or AM 9 kHz steps.

- ① Press [EXT-IN, RADIO] to select "FM".
 - Select "AM" to change the AM frequency steps
- ② Press and hold [RADIO/EXT-IN] on the main unit.
After a few seconds the display changes to display current minimum frequency.
- ③ Continue to hold down [RADIO/EXT-IN] on the main unit.
When the minimum frequency changes, release the button.
 - To return to the original step, repeat steps ① - ③.
 - After the setting is changed, any previously preset frequency will be cleared.

Timer

Setting the clock

This is a 12-hour clock.

- 1 Press [CLOCK/TIMER] to select "CLOCK".
- 2 Within 10 seconds, press [▲, ▼] to set the time.
- 3 Press [OK].



- To display the clock, press [CLOCK/TIMER].
- Reset the clock regularly to maintain accuracy.

Play timer

You can set the timer to come on at a certain time to wake you up. This unit offers 3 optional play timers.

Preparation

- Turn the unit on and set the clock (⇨ above).
- Prepare the music source (disc, radio, iPod/iPhone or AUX) and set the volume.

- 1 Press [CLOCK/TIMER] repeatedly to select "ⓄPLAY 1", "ⓄPLAY 2" or "ⓄPLAY 3".
 - 2 Within 10 seconds, press [▲, ▼] to set the starting time.
 - 3 Press [OK].
 - 4 Set the finishing time by repeating steps 2 and 3.
- To activate the timer
- 5 Press [PLAY, Ⓞ] repeatedly to set the desired play timer on.
 - 6 Press [⏻] to turn the unit off.

Check the settings (When the unit is on or in standby mode)	Press [CLOCK/TIMER] twice. (The setting is displayed.)
Cancel	Press [PLAY, Ⓞ] twice to clear the timer indicator from the display.



- The timer will start at the preset time, with the volume increasing gradually to the preset level.

Sleep timer

The sleep timer can turn the unit off after a set time.

Press [SLEEP] to turn the sleep function on or off.

30MIN → 60MIN → 90MIN → 120MIN
 ↑ OFF (Cancel) ↓

Press [SLEEP] once to check the remaining time.

- The play timer and sleep timer can be used together. The sleep timer always has the priority. Be sure not to overlap the timer settings.
- When "AUTO OFF" is "ON" and the unit is left unused for about 30 minutes, the unit will shut down even if the play time or sleep time has not expired.

Listening to audio from iPod or iPhone

Inserting/Removing an iPod/iPhone

■ Inserting an iPod/iPhone

- 1 Open the sliding door. (⇒ 9)
- 2 Insert the suitable dock adapter (not supplied) for the iPod/iPhone.

- Insert the side of the iPod/iPhone dock adapter with the clips facing towards you first and then push the opposite side until it clicks into place.

- (A) Clips
- (B) Dock adapter
- (C) iPod/iPhone docking switch lever
- (D) Connector

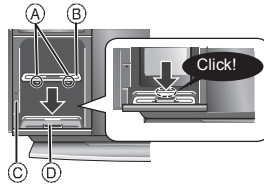

- 3 Press [▲] to unlock the iPod/iPhone dock and then pull the docking switch lever to tilt the iPod/iPhone dock.

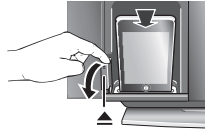

- 4 Connect the iPod/iPhone (not supplied) firmly.

- Be sure to remove the iPod/iPhone from its case.

- 5 Push the docking switch lever back until it clicks into place.



- 6 Close the sliding door. (⇒ 9)

■ Removing an iPod/iPhone

- ① Repeat step 1 and 3 (⇒ above).
- ② To remove, simply pull the iPod/iPhone straight out.
- ③ Repeat step 5 and 6 (⇒ above).



- If the iPod/iPhone dock is not tilted when connecting or disconnecting the iPod/iPhone, it may cause damage to the connector.
- Be sure to use a dock adapter that is compatible with your iPod/iPhone. To purchase a dock adapter, consult your iPod/iPhone dealer.
- Reduce the volume of the main unit to minimum before connecting or disconnecting the iPod/iPhone.

iPod operations

Preparation

Press [iPod] (HC55: [Ⓢ], iPod) repeatedly to select "IPOD".

Play	Press [▶/].
Pause	Press [▶/] or [■]. Press again to resume play.
Skip track	Press [◀◀] or [▶▶].
Search the current track	Press and hold [◀◀] or [▶▶].
Display iPod/iPhone menu/return to previous menu	Press [iPod MENU] in the play mode. (Remote control only)
Select contents from iPod/iPhone menu	Press [▲, ▼] and then [OK]. (Remote control only)

- The operations may vary or not work depending on the iPod/iPhone models.

■ Compatible iPod/iPhone (as of January 2011)

Compatibility depends on the software version of your iPod/iPhone.

Name	Memory size
iPod touch 4rd generation	8 GB, 32 GB, 64 GB
iPod nano 6th generation	8 GB, 16 GB
iPod touch 3rd generation	32 GB, 64 GB
iPod nano 5th generation (video camera)	8 GB, 16 GB
iPod touch 2nd generation	8 GB, 16 GB, 32 GB
iPod classic	120 GB, 160 GB (2009)
iPod nano 4th generation (video)	8 GB, 16 GB
iPod classic	160 GB (2007)
iPod touch 1st generation	8 GB, 16 GB, 32 GB
iPod nano 3rd generation (video)	4 GB, 8 GB
iPod classic	80 GB
iPod nano 2nd generation (aluminum)	2 GB, 4 GB, 8 GB
iPod 5th generation (video)	60 GB, 80 GB
iPod 5th generation (video)	30 GB
iPod nano 1st generation	1 GB, 2 GB, 4 GB
iPhone 4	16 GB, 32 GB
iPhone 3GS	8 GB, 16 GB, 32 GB
iPhone 3G	8 GB, 16 GB
iPhone	4 GB, 8 GB, 16 GB

- Depending on the model, it may be necessary to remove the iPod/iPhone and select the album, artist, etc. on the iPod/iPhone.

Notes on iPhone:

- All phone features can only be controlled by the iPhone's touch screen.
- The unit does not display incoming calls or the phone status (Connect iPhone to this unit via Bluetooth to enjoy extended capabilities).
- The ringtone of incoming call can be heard from the iPhone's speaker. When the unit is in iPod/iPhone mode, the ringtone can also be heard from the unit's speakers (Connect iPhone to this unit via Bluetooth to enjoy extended capabilities).
- Connecting or disconnecting the iPhone from the unit will not cancel a call.
- There is no Apple Inc. specification that will guarantee the iPhone responses above. iPhone responses may vary on new iPhone models or iPhone new software updates.

■ Charging the iPod/iPhone

- When iPod/iPhone is being charged in standby mode, "IPOD CHARGING" is shown on the main unit's display.
- Check iPod/iPhone to see if the battery is fully charged. If you are not using iPod/iPhone for an extended period of time after recharging has completed, disconnect it from the main unit as the battery will be depleted naturally. (Once fully recharged, additional recharging will not occur.)

HC55

Listening to the Internet Radio

This unit can output internet radio if "vTuner for Panasonic" is installed on your iPhone/iPod touch.

- Visit the below website for the following information about "vTuner for Panasonic":

<http://radio.vtuner.com/panasonic/en/>

(Compatible iPhone/iPod touch models and software versions, purchasing, installation and operation details.)

Preparation

Install "vTuner for Panasonic" to your iPhone/iPod touch.

- 1 Insert the iPhone/iPod touch to this unit.
- 2 Press [Ⓢ, iPod] repeatedly to select "INTERNET RADIO".
"vTuner for Panasonic" starts.

HC55 Using a Bluetooth compatible device

About using Bluetooth

What is Bluetooth?

Bluetooth technology allows you to make a wireless connection with another electronic device.

Frequency band used

This unit uses the 2.4 GHz frequency band, however other devices may use this frequency as well. To avoid interference with other wireless devices, please follow the cautions listed below.

Certification of this device

This unit conforms to frequency restrictions and has received certification based on frequency laws, so a wireless permit is not necessary.

However, the following actions are punishable by law in some countries:

- Taking apart/modifying the unit.
- Removing specification indications from the rear part of this unit.

Usage restrictions

- Wireless transmission and/or usage with all Bluetooth equipped devices is not guaranteed.
- Compatible mobile phones capable of wireless transmission include and comply to standards set by the Bluetooth SIG, Inc. However, if the mobile phone is optimized to meet standard specifications, some functions may work. Even so, depending on the specifications and settings of the mobile phone, a connection may not be established, nor are the methods of operation, display, or operation guaranteed.
- This unit supports Bluetooth security features, however depending on the operating environment and/or settings, this security may not be sufficient. Use caution when transmitting data wirelessly.
- Please be aware that Panasonic accepts no responsibility for data and/or information that may be compromised during a wireless transmission.

Range of use

Use this device within an unobstructed 10 m (33 ft) range. The range of usage or perimeter may be shortened depending on any obstructions, devices causing interference, other people in the room, or the construction of the building. Please note that the range mentioned above is not guaranteed.

Effects from other devices

- It is possible that this unit may not operate correctly or you may experience other effects of instability such as "broken up" audio, etc. when other devices are placed within close proximity. Therefore, in order to prevent signal interference, we recommend separating this unit from the following devices during use:

Microwave oven/Wireless LAN/Electronic devices/Audio & Video devices/Office Assistant machines & devices/Digital cordless phones/Fax machines, etc.

- If you live in close proximity to a broadcasting studio and the signal is too strong, the unit may not operate correctly.
- When using a notebook PC with a wireless LAN transmitter, do not use this unit and the wireless LAN at the same time.
- If you are still experiencing noise even outside of the 5 m (16.4 ft) range of a wireless LAN device, turn the power to the wireless LAN device off.

Intended usage limitations

This unit is intended for normal, general use. This unit is not developed or manufactured with the intention of use in "high safety" or hazardous occupations. Do not use this unit in these kinds of environments or occupations.

* The following examples require extreme caution, and can directly result in loss of life, or extreme bodily harm.

e.g.)

Nuclear Engineering, and control of a nuclear reaction/automated control of aircraft/air traffic control management/controlling movement of heavy freight systems/control of life support or extension systems/control of weapons systems and/or missile launch systems, etc.

Bluetooth pairing

Preparation

Pair the Bluetooth device with this unit to create an audio connection.

- 1 Press [**0**, iPod] repeatedly to select "BLUETOOTH".
When using it for the first time, it enters pairing mode automatically.
- 2 While this unit is in pairing mode, access the Bluetooth menu of the Bluetooth device and execute a Bluetooth search to find this unit (SC-HC55).
 - Please refer to the Bluetooth device user manual for further instruction on how to connect a Bluetooth device.
 - If prompted for the passkey, enter "0000".
- 3 If pairing is successful, the paired device's name will be displayed for 2 seconds. The Bluetooth indicator lights up. The unit is now ready to be used with the Bluetooth device.



- Make sure the Bluetooth device supports A2DP (Advance Audio Distribution Profile).
- This unit supports the A2DP reception which is copyright-protected by SCMS-T method.
- A2DP enables you to stream stereo sound from an audio source (mobile phone, PC or laptop) to this unit via Bluetooth.
- Depending on the specification or setting of mobile phones, connection may not be established, or operation and display may vary.
- You can register up to 6 devices into this unit. Disconnect the current Bluetooth device and refer to "To register more devices" (→ 14).
- If you register more than the maximum device number, the oldest device in connection history will be overwritten.
- If a registered device is re-registered, it will be overwritten.

Basic play

Pair the Bluetooth device with this unit to create an audio connection.

- 1 Press [**0**, iPod] repeatedly to select "BLUETOOTH".
- 2 On the Bluetooth device:
Select this unit (SC-HC55) on the Bluetooth setup screen to make the connection.
- 3 On the Bluetooth device:
Start playback of a music source.
 - If the device is connected, the music will be heard on this unit.
 - The Bluetooth indicator lights when there is a connection.
 - Please refer to the Bluetooth device user manual if required.
- 4 You can also make the following controls with the remote control.

Play	Press [▶/] to start play.
Stop	Press [■].
Pause	Press [▶/]. Press again to resume play.
Skip track	Press [◀◀] or [▶▶].
Display information	Press [DISPLAY] repeatedly.

HC55 Using a Bluetooth compatible device (Continued)



- To utilize these functions, the Bluetooth device must support AVRCP (Audio Video Remote Control Profile).
- This unit cannot transmit data to a Bluetooth device.
- When playing iPod/iPhone by Bluetooth with the main unit, intermittent sound may be experienced if you leave the iPod/iPhone Bluetooth menu screen active or when making Bluetooth registration and connection. If this occurs, please exit the iPod/iPhone Bluetooth menu screen.
- When playing music by iPod/iPhone via Bluetooth connection and the iPod/iPhone is connected into this unit iPod/iPhone dock, the audio will not be re-produced while "BLUETOOTH" is selected. Select "IPOD" to continue enjoying the music.

Input level

You can select the sound input level of the Bluetooth device.

- 1 Press [**0**, iPod] repeatedly to select "BLUETOOTH".
- 2 Press [SOUND] repeatedly to select "INPUT LEVEL".
- 3 Press [◀, ▶] to select "0", "+1" or "+2".
 - Select "0" if the sound is distorted.

Display function

Press [DISPLAY] repeatedly to view the information of the current connected device.

BLUETOOTH → Connected device name
 ↑ Connected profiles ←

Hands-Free Profile (HFP)

This unit works as a Bluetooth hands-free for your mobile phones.

To answer a call ("IN CALL" blinks)	Press [↶]. "CALLING" starts blinking on the display (Talk into the unit's microphone). Press [↶] again to transfer the call to the mobile phones ("TRANSFER" blinks. You may now converse using the mobile phone).
To cancel a call	Press [✕].
To adjust the sound volume	Press [+ , VOL , -] (Adjustable from "TEL VOL 1" to "TEL VOL 10").
To mute the microphone	Press [MUTE]. Press again to cancel. (During "MIC MUTE", the caller is not able to hear your voice).



- This unit does not work with Headset Profile (HSP).
- When the mobile phone is too close to the microphone of this unit, noise may occur. Always keep the mobile phone away from the microphone of this unit when making a call.
- The audio from a disc will be paused while calling in hands-free mode.

Disconnecting a Bluetooth device

- 1 Press [**0**, iPod] repeatedly to select "BLUETOOTH".
- 2 Press [**0** MENU] to display "DISCONNECT?" and then press [OK].
A confirmation message is displayed.
- 3 Press [◀, ▶] to select "YES" and then press [OK].



- The connection can also be stopped when you disable Bluetooth transmission on the connected Bluetooth device.

Advanced functions

Preparation

Press [**0**, iPod] repeatedly to select "BLUETOOTH".

- These functions are unavailable if a device is connected. Disconnect the Bluetooth devices to display these functions.

To register more devices

- 1 Press [**0** MENU] repeatedly to select "NEW DEV." and then press [OK].
 - The unit enters pairing mode and "PAIRING" starts blinking on the display.
- 2 While this unit is in pairing mode, access the Bluetooth menu of the Bluetooth device and execute a Bluetooth search to find this unit (SC-HC55).
 - If prompted for the passkey, enter "0000".

To select communication quality

- 1 Press [**0** MENU] repeatedly to select "LINK MODE".
- 2 Press [◀, ▶] to select the following modes and then press [OK].
 MODE 1: Connection with emphasis on communication stability
 MODE 2: Connection with high bit rate for good audio quality (Communication might easily be disconnected in this mode, select "MODE 1" if this occurs).

To select Auto Link mode

- 1 Press [**0** MENU] repeatedly to select "AUTO LINK".
- 2 Press [◀, ▶] to select the following modes and then press [OK].
 ON: This unit will automatically select "BLUETOOTH" when a Bluetooth device is connected.
 OFF



- When "LINKING" is displayed, pressing [**0** MENU] is invalid.
- Auto Link works only if your device supports A2DP.
- The communication quality settings also depend on the settings on the connected device. If the communication quality of the connected device is set for stable communication, the quality of the audio will remain low even if this unit is set to "MODE 2".

Others

Changing the main unit and remote control mode

Other Panasonic audio/video equipment may start functioning when you operate the unit using the supplied remote control. You can operate this unit in another mode by setting the remote control operating mode to "REMOTE 2".

The main unit and remote control must be set to the same mode.

- 1 Press [EXT-IN, RADIO] to select "AUX".
- 2 Press and hold [RADIO/EXT-IN] on the main unit and [2] on the remote control until the main unit's display shows "REMOTE 2".
- 3 Press and hold [OK] and [2] on the remote control for at least 4 seconds.

To change the mode back to "REMOTE 1", repeat the steps above by replacing [2] with [1].

Memory reset (Initialization)

When the following situations occur, reset the memory:

- There is no response when buttons are pressed.
- You want to clear and reset the memory contents.

■ To reset memory

- 1 Disconnect the AC power supply cord. (Wait for at least 3 minutes before proceeding to step 2.)
- 2 While pressing and holding down [POWER, ⏻] on the main unit, reconnect the AC power supply cord.
"-----" appears on the display.
- 3 Release [POWER, ⏻].
All the settings are returned to the factory preset. You will need to reset the memory items.

Troubleshooting

Before requesting service, make the following checks. If you are in doubt about some of the check points, or if the solutions indicated in the following guide do not solve the problem, refer to "Customer Services Directory (United States and Puerto Rico)" on page 26 if you reside in the U.S.A. or Puerto Rico, or refer to "Limited Warranty (ONLY FOR CANADA)" on page 27 if you reside in Canada.

Common problems

Incorrect display or play will not start.

- You have not inserted the disc properly. Insert it correctly.
- The disc is scratched or dirty (Tracks skipped).
- There is moisture on the lens. Wait for about an hour and then try again.

MP3 cannot be read.

- You may not be able to play MP3 if you have copied a multi-session disc that has no data between sessions.
- When creating a multi-session disc, it is necessary to close the session.
- The amount of data on the disc is too small. Set the amount of data to above 5 MB.

Noise is heard or no sound.

- While playing MP3, noise may occur if the recording is poor.
- Keep this unit away from mobile phones if the interference is apparent.

- Turn the volume up.
- Switch the unit off, check and correct the connection and then switch the unit on. Causes include straining of the speakers through excessive volume or power and using the unit in a hot environment.

Humming heard during play.

- An AC power supply cord or fluorescent light is near the cords. Keep other appliances and cords away from this unit's cables.

A beat sound or noise is heard while receiving radio broadcast.

- Switch the television or other audio player off or separate it from the unit.
- Switch the portable audio player off if connected to the EXT-IN AUX port.

A low hum or noise is heard during AM broadcast.

- Keep the antenna away from other cables and cords.
- Keep the AM antenna away from the unit.

The picture on the television near the unit disappears or stripes appear on the screen.

- The location and orientation of the antenna are incorrect.
- The television antenna wire is too close to the unit. Separate the antenna wire of the television from the unit.

No response when remote control buttons are pressed.

- Check that the battery is inserted correctly (⇨ 4).

HC55 Open/close sensor

The sliding door does not open (or malfunctions).

- Is the unit turned on?
- Is the open/close sensor turned off? (⇨ 9)
- During CD playback or pause, the CD operation side of the sliding door will not open.
- The open/close sensor may not react to dark objects.
- Depending on the lighting, the open/close sensor may malfunction.
In this case, try moving the unit to a different place. (Do not place this unit under strong lighting.)
- When the open/close sensor is on, the sliding door may open/close while operating the buttons on the top of the unit.
In this case, use the remote control.

The open/close button lights are flashing.

- If there is an object close to both open/close sensors, both open/close button lights will flash and the open/close sensor will not function. In this case, move the unit away from the object, or vice versa. (It will take approx. 10 sec. for the unit to check if the clearance is sufficient.)

The open/close sensor sound effect cannot be heard when the sliding door opens/closes.

- This is normal while listening to the radio, during playback, etc. or when linked to a Bluetooth device.

Troubleshooting (Continued)

iPod/iPhone operations

iPod/iPhone does not turn on.

Cannot operate with [iPod MENU] button.

- Verify that the iPod/iPhone battery is not depleted before connecting it to the unit.
- Before inserting the iPod/iPhone into the dock, turn both the unit and the iPod/iPhone off. Turn the power on and select the appropriate source.

No sound is heard from the speakers.

- The iPod/iPhone is not inserted correctly into the dock. Turn the iPod/iPhone off and remove it from the dock connector. Reinsert it and turn it on again.
- Make sure that the iPod/iPhone is actually playing something.
- Adjust the volume.

Distorted sound or the sound level is too low.

- Make sure the equalizer function of the iPod/iPhone is turned off.

iPod/iPhone cannot be controlled by the remote control or main unit.

- Make sure the iPod/iPhone is inserted properly into the dock.
- Check the dock connection and make sure that iPod/iPhone is selected as the source of music (⇒ 12).

iPod/iPhone does not charge

- Check all connections (⇒ 5, 12).

HC55 Bluetooth operations

The name of the connected device is shown as “*”.

- Character that cannot be displayed will be replaced by “*”.
- An unknown device name is detected and displayed as “*****”.

Noise is heard or broken sound.

- The Bluetooth communication distance has exceeded 10 m (33 ft). Bring the device closer to the unit.
- There are obstructions between the device and the unit. Remove or avoid the obstacles.
- Select “MODE 1” to improve connection quality (⇒ 14).
- Interference from mobile phones.

Displayed messages

The following messages or service numbers appear on the unit’s display when something unusual is detected during startup and use.

“--:--”

- You plugged the AC power supply cord in for the first time or there was a power failure recently. Set the time (⇒ 11).

“ADJUST CLOCK”

- Clock is not set. Adjust the clock accordingly.

“ADJUST TIMER”

- Play timer is not set. Adjust the play timer accordingly.

“PGM FULL”

- The number of programmed tracks is limited to 24. No further tracks can be programmed.

“NO PLAY”

- A CD-ROM disc that is not in CD-DA or MP3 format is inserted. It cannot be played.
- Check the content. Only MP3 format files can be played.

“ERROR”

- Incorrect operation is performed. Read the instructions and try again.

“F61” or “F76”

- There is a power supply problem. Consult the dealer.

“AUTO OFF”

- The unit has been left unused for about 30 minutes and will shut down in a minute. Press any button to cancel it.

“ILLEGAL OPEN”

- Sliding door is not in correct position. Turn the unit off and on again.

“NODEVICE”

- The iPod/iPhone device is not inserted correctly. Read the instructions and try again (⇒ 12).

“REMOTE 1”

- The main unit is in “REMOTE 1” mode. Switch the remote control to “REMOTE 1” mode (⇒ 15).

“REMOTE 2”

- The main unit is in “REMOTE 2” mode. Switch the remote control to “REMOTE 2” mode (⇒ 15).

“DIMMER”

- Appears 10 seconds after the volume is turned to “0”.

“F70”

- There is a Bluetooth module problem. Disconnect the AC power supply cord and consult your dealer.

“NO DISC”

- Insert the disc to be played (⇒ 9).

“NOT SUPPORTED”

- You have inserted an iPod/iPhone that cannot be played (⇒ 12).

HC55 “START ERROR”

- Check the iPhone/iPod touch.
Visit the below website for more information:
<http://radio.vtuner.com/panasonic/en/>

“UNLOCKED”

- The iPod/iPhone docking switch lever is not locked in position. Make sure that the iPod/iPhone docking switch lever is properly pushed back into place (⇒ 12).

HC55 “CANNOT SET”

- Select an audio source other than “BLUETOOTH” or “INTERNET RADIO”.

Specifications

AMPLIFIER SECTION

RMS Output Power Stereo mode	
Front Ch (both ch driven)	20 W per channel (6 Ω), 1 kHz, 10 % THD
Total RMS Stereo mode power	40 W
FTC Output Power Stereo mode	
Front Ch (both ch driven)	15 W per channel (6 Ω), 20 Hz to 20 kHz, 10 % THD
Total FTC Stereo mode power	30 W

TUNER SECTION

Preset Memory	FM 30 stations AM 15 stations
Frequency Modulation (FM)	
Frequency range	87.9 MHz to 107.9 MHz (200 kHz step) 87.5 MHz to 108.0 MHz (100 kHz step)
Antenna terminals	75 Ω (unbalanced)
Amplitude Modulation (AM)	
Frequency range	520 kHz to 1710 kHz (10 kHz step) 522 kHz to 1629 kHz (9 kHz step)

DISC SECTION

Disc played [8 cm (3") or 12 cm (5")]	CD, CD-R/RW (CD-DA, MP3*)
Pick up	
Wavelength	790 nm
Laser power	For U.S.A. CLASS I For Canada CLASS 1, CLASS 1M
Audio Output (Disc)	
Number of channels	FL, FR, 2 ch

* MPEG-1 Layer 3, MPEG-2 Layer 3

SPEAKER SECTION

HC55	
Type	2 way, 2 speaker system (Passive Radiator)
Speaker unit(s)	
Woofer	6.5 cm (2 1/2") Cone type×1 per channel
Tweeter	1.5 cm (5/8") Piezo type×1 per channel
Passive Radiator	8 cm (3 1/8")×2 per channel
Impedance	6 Ω
HC35	
Type	1 way, 1 speaker system (Passive Radiator)
Speaker unit(s)	
Full range	6.5 cm (2 1/2") Cone type×1 per channel
Passive Radiator	8 cm (3 1/8")×2 per channel
Impedance	6 Ω

HC55 BLUETOOTH SECTION

Bluetooth system specification	V2.1 + EDR
Wireless equipment classification	Class 2 (2.5 mW)
Supported profiles	A2DP, AVRCP, HFP
Frequency band	2402 MHz to 2480 MHz (Adaptive Frequency Hopping)
Driving distance	10 m (33 ft) Line of Sight (iPhone 4, at height 1 m (3.3 ft), in "MODE 1")

TERMINAL SECTION

Phone jack	
Terminal	Stereo, Ø3.5 mm (1/8") jack
AUX (Rear)	
Terminal	Stereo, Ø3.5 mm (1/8") jack

GENERAL

Power consumption	25 W
Power consumption in standby mode	Approx. 0.1 W
Power supply	AC 120 V, 60 Hz
Dimensions (W×H×D)	With stand 480 mm×194 mm×84 mm (19"×7 3/4"×3 1/2") Without stand 480 mm×194 mm×69 mm (19"×7 3/4"×2 3/4")
Mass (Weight)	Approx. 2.4 kg (5.3 lbs)
Operating temperature range	0 °C to +40 °C (+32 °F to +104 °F)
Operating humidity range	35 % to 80 % RH (no condensation)



- Specifications are subject to change without notice.
- Mass and dimensions are approximate.
- Total harmonic distortion is measured by a digital spectrum analyzer.

Spanish Quick Reference/ Referencia rápida en español

Conexiones

Vista posterior

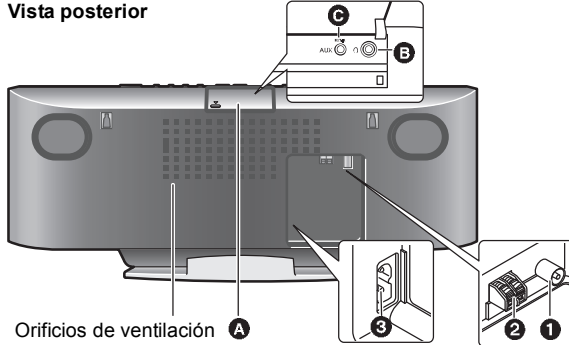

Conexiones básicas

1 Conecte la antena interior FM.

- Fije con cinta la antena a un muro o columna en un lugar que tenga la menor cantidad de interferencia.

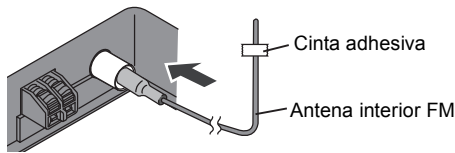

2 Conecte la antena de cuadro AM.

- Mantenga el cable de la antena suelto alejado de otros cables o hilos.
- Ⓐ Coloque la antena en forma vertical en su base hasta que quede calzada y haga clic.
- Ⓑ Antena de cuadro AM

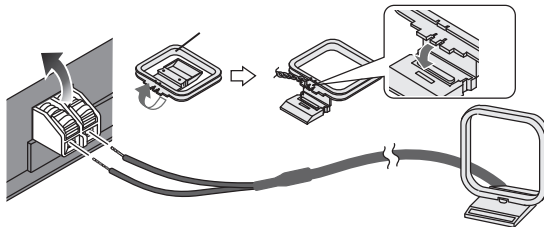

3 Conecte el cable de alimentación AC.

Conecte el cable de alimentación AC después de que todas las demás conexiones estén completas. Encienda la unidad después de unos segundos.

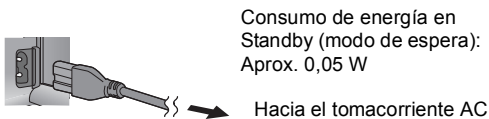

Consumo de energía en Standby (modo de espera):
Aprox. 0,05 W

Hacia el tomacorriente AC

Otras Conexiones

Abra la tapa EXT-IN AUX/Tapa para conectar los auriculares o dispositivos de música externos (por ejemplo, reproductor MP3).

Empuje la parte saliente para abrir la tapa Ⓐ.

Vista superior



■ Conecte los auriculares (no provistos)

Reduzca el volumen y conecte los auriculares.

Tipo de enchufe: Ø3,5 mm (1/8") estéreo Ⓑ



- Para evitar daños a la audición, evite escuchar durante períodos prolongados.
- La excesiva presión sonora de audífonos y auriculares puede causar pérdida de la audición.

■ Conectar un dispositivo de música externo (para modo AUX)

① Enchufe el cable de audio (no provisto) en el jack EXT-IN AUX Ⓒ.

Tipo de enchufe: Ø3,5 mm (1/8") estéreo

② Presione [EXT-IN, RADIO] repetidamente para seleccionar "AUX" y comience la reproducción en el dispositivo conectado.

EXT-IN



Usted puede seleccionar el nivel de sonido de entrada del dispositivo externo.

HC55 ① Presione [SOUND] repetidamente para seleccionar "INPUT LEVEL".

② Presione [◀, ▶] para seleccionar "HIGH" o "NORMAL".

HC35 Presione [INPUT LEVEL] repetidamente para seleccionar "HIGH" o "NORMAL".

- Apague el ecualizador o baje el volumen del dispositivo externo para reducir la señal de entrada. El nivel alto de la señal de entrada distorsiona el sonido.
- Para más detalles, consulte el manual de instrucciones del otro equipo.
- Los cables y dispositivos no se suministran.

Guía de referencia del mando a distancia

Mando a distancia

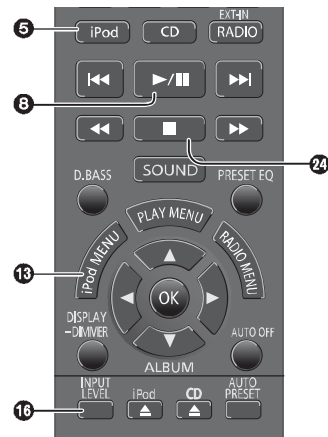

Vista frontal

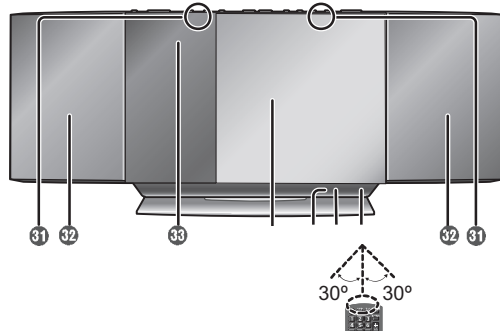

- 1** [SLEEP] (⇒ 22)
- 2** Interruptor Standby/On [⏻], [POWER, ⏻/⏿] (⇒ 20, 22)
Presione para conmutar la unidad desde el modo On a Standby, o viceversa. En el modo Standby, la unidad sigue consumiendo una pequeña cantidad de energía.
- 3** Botones numéricos [1-9, 0, ≧10] (⇒ 20, 21)
Para seleccionar un número de 2 dígitos
Por ejemplo 16: [≧10] → [1] → [6]
Para seleccionar un número de 3 dígitos
Por ejemplo 226: [≧10] → [≧10] → [2] → [2] → [6]
4 [DEL] (⇒ 21)
- 5** **HC55** [⏻], iPod] (⇒ 23, 24)
HC35 [iPod] (⇒ 23)
- 6** [CD] (⇒ 20)
- 7** [◀◀], [▶▶] (⇒ 20, 21, 22, 23, 24)
- 8** [▶/||] (⇒ 20, 21, 23)
HC55 [↶] (⇒ 24)
- 9** [◀◀], [▶▶] (⇒ 20, 21, 23, 24)
- 10** [SOUND] (⇒ 18, 20, 22)
- 11** [D.BASS] (⇒ 22)
- 12** [PLAY MENU] (⇒ 21)
- 13** [iPod MENU] (⇒ 23)
HC55 [⊗] MENU]
- 14** [▲, ▼, ◀, ▶], [OK] (⇒ 18, 21, 23, 24)
- 15** [DISPLAY] (⇒ 20)
[-DIMMER]
- 16** **HC55** [OPEN/CLOSE SENSOR] (⇒ 20)
HC35 [INPUT LEVEL] (⇒ 18)
- 17** [iPod ▲] (⇒ 20)
[iPod ▲, OPEN/CLOSE] **HC55** Indicador de la actividad del sensor
- 18** [PLAY, ⏻] (⇒ 22)
- 19** [CLOCK/TIMER] (⇒ 22)
- 20** [PROGRAM] (⇒ 21)
- 21** [+ , VOL - , -]
[- VOLUME +] (⇒ 24)
- 22** [MUTE] (⇒ 24)
Silencia el sonido. Presione nuevamente para cancelar. "MUTE" también se cancela cuando se regula el volumen o se apaga la unidad.
- 23** [EXT-IN, RADIO]
- 24** [■] (⇒ 20, 21, 23, 24)
HC55 [↷] (⇒ 24)
- 25** [PRESET EQ] (⇒ 22)
- 26** [RADIO MENU] (⇒ 21)
- 27** [AUTO OFF]
Esta función le permite apagar la unidad (excepto en modo radio) después de que no se usa durante aproximadamente 30 minutos.
- 28** [AUTO PRESET] (⇒ 21)
- 29** [CD ▲] (⇒ 20)
[CD ▲, OPEN/CLOSE] **HC55** Indicador de la actividad del sensor
- 30** Indicador de Standby
- 31** **HC55** Sensor Abrir/Cerrar (⇒ 20)
- 32** Altavoz
- 33** Visor
- 34** Puerta deslizante
- 35** **HC55** Micrófono (⇒ 24)
- 36** **HC55** Indicador de Bluetooth (⇒ 24)
- 37** Sensor de señal del mando a distancia
Distancia:
Aprox. 7 m (23 pies) directamente en el frente.

Unidad principal

Los botones tales como **2** funcionan igual que el mando a distancia. Se pueden usar indistintamente.

Vista superior

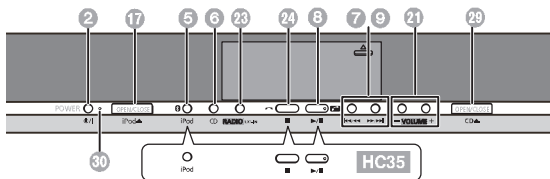

Información del mando a distancia

Inserte de forma tal que los polos (+ y -) concuerden con los del mando a distancia.

Coloque primero este lado adentro.

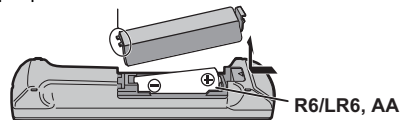

● Use baterías alcalinas o de manganeso.

Abrir/Cerrar la puerta deslizante

Preparación

Presione [⏻] para encender la unidad.

Abrir la puerta deslizante

Para operaciones con discos:

Ⓐ Mientras la puerta deslizante está cerrada, presione [CD ▲] para abrirla.

Para operaciones con iPod/iPhone:

Ⓑ Mientras la puerta deslizante está cerrada, presione [iPod ▲] para abrirla.

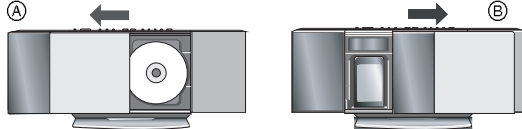

Cerrar la puerta deslizante

Presione [CD ▲] o [iPod ▲] nuevamente.

● Mantenga los dedos alejados de la puerta deslizante cuando se está cerrando para evitar posibles daños menores.



- Si fuerza la puerta deslizante para cerrarla, se puede dañar.
- Al extraer el CD, tenga cuidado de no golpear la puerta deslizante.
- La puerta deslizante no se cerrará si la palanca del interruptor del conector no se coloca en la posición original.

HC55 Sensor Apertura/Cierre

Con esta función, la puerta deslizante se puede abrir sin presionar un botón. La puerta se abrirá y cerrará cuando mueva su mano sobre el sensor.

Para operaciones con discos:

Mientras la puerta deslizante está cerrada, mueva su mano de Ⓑ a Ⓐ.

● Para cerrar la puerta deslizante, mueva su mano de Ⓐ a Ⓑ.

Para operaciones con iPod/iPhone:

Mientras la puerta deslizante está cerrada, mueva su mano de Ⓐ a Ⓑ.

● Para cerrar la puerta deslizante, mueva su mano de Ⓑ a Ⓐ.



Para deshabilitar el sensor de Apertura/Cierre Presione [OPEN/CLOSE SENSOR].

● Cada vez que pulsa el botón, el sensor se enciende ("ON SENSOR") o apaga ("OFF SENSOR").

Para agregar un efecto de sonido cuando la puerta deslizante se abre/cierra (cuando se usa el sensor).

① Presione [SOUND] repetidamente para seleccionar "BUZZER".

② Presione [◀] o [▶] para seleccionar el siguiente ajuste.

- LOW:** Fije el nivel de sonido bajo.
MID: Fije el nivel de sonido medio.
HIGH: Fije el nivel de sonido alto.
OFF: Apague el efecto de sonido.



- El sensor de apertura/cierre podría activarse accidentalmente si un objeto, la mano, una parte del brazo, animales domésticos o niños se mueven cerca de él.
- Si el sensor de apertura/cierre no funciona o el rango de reacción disminuye, abra/cierre la puerta deslizante usando los botones de la unidad o el mando a distancia.
- La puerta deslizante no se abrirá durante la reproducción de CD.

Operaciones con discos

Insertar un disco

- 1 Presione [⏻] para encender la unidad.
- 2 Abra la puerta deslizante. (⇒ izquierda)
- 3 Con la etiqueta del disco volteada hacia usted, incline el disco sobre la bandeja ubicada debajo de la puerta deslizante.
- 4 Coloque el disco sobre el sujetador central y luego empuje el disco hacia abajo hasta que quede bien calzado y haga clic.
- 5 Cierre la puerta deslizante. (⇒ izquierda)

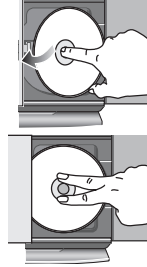

Sacar un disco

- ① Abra la puerta deslizante.
- ② Sostenga el centro y la parte superior derecha del disco, y tire de la parte superior derecha para separarlo del sujetador.
- ③ Incline el disco para no tocar la puerta deslizante ni las lentes, y sáquelo.

Reproducción básica

- 1 Presione [⏻] para encender la unidad.
- 2 Inserte el disco que desea reproducir (⇒ arriba).
- 3 Presione [CD].
- 4 Presione [▶/||] para comenzar a reproducir.

Detención	Presione [■].
Pausa	Presione [▶/]. Presione nuevamente para reiniciar la reproducción.
Saltear	Presione [◀◀] o [▶▶] para saltar una pista. Presione [▲, ▼] para saltar el álbum. (MP3)
Búsqueda (CD solamente)	Mantenga presionado [◀◀] o [▶▶].
Reproducción de acceso directo (La reproducción inicia en la pista que seleccionó.)	CD: Presione los botones numéricos para seleccionar la pista. MP3: ① Presione [▲, ▼] para seleccionar el álbum. ② Presione [▶▶] una vez y luego los botones numéricos para seleccionar la pista. ● Esta función no funciona durante la reproducción aleatoria o programada. (⇒ 21)
Ver la información del contenido	Presione [DISPLAY] repetidamente durante la reproducción o la pausa. Se despliega la información de la pista actual, etc. ● Cantidad máxima de caracteres desplegados: aproximadamente 30 ● Esta unidad es compatible con etiquetas de la versión 1.0 y 1.1 ID3. Los datos de texto no soportados no se desplegarán.

Repetir la reproducción

Después de realizar los pasos 1-3 de "Reproducción básica" (⇒ 20)

- 1 Presione [PLAY MENU] repetidamente para seleccionar "REPEAT".
- 2 Presione [◀, ▶] para seleccionar "ON REPEAT" y presione [OK].
- 3 Presione [▶/||] para comenzar a reproducir.
 - Para detener la repetición de la reproducción, seleccione "OFF REPEAT" en el paso 3.

Función de modo de reproducción

Después de realizar los pasos 1-3 de "Reproducción básica" (⇒ 20)

- 1 Presione [PLAY MENU] repetidamente para seleccionar "PLAY MODE".
- 2 Presione [◀, ▶] para seleccionar el modo siguiente y presione [OK].

1-TRACK <small>TRK:</small>	Reproduce una pista seleccionada del disco.
1-ALBUM <small>1ALBUM:</small> (MP3 solamente)	Reproduce un álbum seleccionado del disco. <ul style="list-style-type: none"> • Presione [▲, ▼] para seleccionar el álbum.
RANDOM <small>RND:</small>	Reproduce un disco en modo aleatorio.
1-ALBUM RANDOM <small>1ALBUM RND:</small> (MP3 solamente)	Reproduce en modo aleatorio todas las pistas de un álbum seleccionado. <ul style="list-style-type: none"> • Presione [▲, ▼] para seleccionar el álbum.

- 3 Presione [▶/||] para comenzar a reproducir.



- Durante la reproducción aleatoria, no se puede saltar a la pista anterior.
- El modo de reproducción actual se cancela cuando usted abre la puerta deslizante.
- Para repetir la reproducción programada o el modo de reproducción seleccionado, seleccione "ON REPEAT" en PLAY MENU. (⇒ 20)

Reproducción programada

Le permite programar hasta 24 pistas.
Después de realizar los pasos 1-3 de "Reproducción básica" (⇒ 20)

- 1 Presione [PROGRAM] durante el modo de detención.
- 2 **CD:**
Presione los botones numéricos para seleccionar la pista.
 - Para programar más pistas, siga pulsando los botones numéricos.**MP3:**
 - 1 Presione [▲, ▼] para seleccionar el álbum.
 - 2 Presione [▶▶] una vez y luego los botones numéricos para seleccionar la pista.
 - 3 Presione [OK].
 Para programar más pistas, repita los pasos ① - ③.

- 3 Presione [▶/||] para comenzar a reproducir.

Cancelar el modo de programación	Presione [PROGRAM] en el modo de detención para cancelar el indicador "PGM" del visor.
Verificar el contenido del programa	Presione [◀◀] o [▶▶] cuando "PGM" se visualiza en el modo de detención.
Borrar la última pista programada	Presione [DEL] en el modo de detención.
Borrar todas las pistas programadas	<ol style="list-style-type: none"> 1 Presione [■] en el modo de detención. 2 Presione [■] nuevamente mientras parpadea "CLR ALL".



- La memoria del programa se borra cuando abre la puerta deslizante.

Operaciones con la radio

Sintonización manual

- 1 Presione [EXT-IN, RADIO] repetidamente para seleccionar "FM" o "AM".
- 2 Presione [◀◀] o [▶▶] para seleccionar la frecuencia de la estación requerida.
 - "ST" se visualiza cuando se está recibiendo de una emisora FM estéreo.
 - Para sintonizar automáticamente, mantenga presionado [◀◀] o [▶▶] hasta que la frecuencia comience a cambiar rápidamente.
 - Para cancelar la sintonización automática, presione [◀◀] o [▶▶] nuevamente.
 - La sintonización automática puede no funcionar cuando hay exceso de interferencia.

Para mejorar la calidad del sonido FM

- 1 Presione [RADIO MENU] mientras recibe emisoras FM.
- 2 Presione [▲, ▼] para seleccionar "FM MODE".
- 3 Presione [◀, ▶] para seleccionar "MONO".
 - Seleccione "STEREO" en el paso ③ para volver a las emisoras estéreo.
 - "MONO" también se cancela si se cambia la frecuencia.

Para mejorar la calidad de sonido AM

- 1 Presione [RADIO MENU] para seleccionar "B.PROOF" mientras recibe transmisiones AM.
- 2 Presione [◀, ▶] para seleccionar la prueba beat ("BP 1" o "BP 2") y presione [OK].
 - Este ajuste se restaura a "BP 1" cuando se realizan cambios (por ejemplo, se cambia la frecuencia).

Predefinición de memoria

Usted puede predefinir hasta 30 canales FM y 15 canales AM.

Preparación

Presione [EXT-IN, RADIO] repetidamente para seleccionar "FM" o "AM".

Predefinición automática

- 1 Presione [OK] para conmutar la frecuencia entre "LOWEST" y "CURRENT".
- 2 Presione [AUTO PRESET].
"PGM" comienza a destellar y la radio comienza a predefinir todas las estaciones que puede recibir en los canales, en orden ascendente.

Predefinición manual

- 1 Presione [◀◀] o [▶▶] para sintonizar la estación requerida.
- 2 Presione [PROGRAM].
- 3 Mientras "PGM" destella, presione los botones numéricos para seleccionar un canal.
 - La estación que ocupa un canal se borra si otra estación se predefine en ese canal.
 - Para predefinir más estaciones, repita el paso ① - ③.

Seleccionar una estación predefinida

- Presione [◀◀] o [▶▶] para seleccionar el canal.
- Alternativamente, presione los botones numéricos para seleccionar el canal.

Definición de asignación FM/AM

Esta unidad se define en fábrica como FM 0,2 MHz y AM 10 kHz, pero puede cambiar estos ajustes para recibir emisoras asignadas en el paso FM 0,1 MHz o AM 9 kHz.

- 1 Presione [EXT-IN, RADIO] para seleccionar "FM".
 - Seleccione "AM" para cambiar a los pasos de frecuencia AM.
- 2 Mantenga presionado [RADIO/EXT-IN] en la unidad principal.
Después de unos segundos, el visor cambia y muestra la frecuencia mínima actual.
- 3 Continúe manteniendo pulsando [RADIO/EXT-IN] en la unidad principal.
Cuando la frecuencia mínima actual cambia, suelte el botón.
 - Para volver al paso original, repita los pasos ① a ③.
 - Después de que se cambia la definición, se borrará cualquier frecuencia previa.

Ajuste de sonido

Se pueden agregar los siguientes efectos de sonido a la salida de audio.

EQ predeterminado	Presione [PRESET EQ] repetidamente para seleccionar "HEAVY", "SOFT", "CLEAR", "VOCAL" o "FLAT".
Bajos o agudos	① Presione [SOUND] repetidamente para seleccionar "BASS" o "TREBLE". ② Presione [◀, ▶] para graduar el nivel (-4 a +4).
Sonido Surround	① Presione [SOUND] repetidamente para seleccionar "SURROUND". ② Presione [◀, ▶] para seleccionar "ON SURROUND". ● Para cancelar el sonido surround, seleccione "OFF SURROUND" en el paso ②. ● Si la interferencia en la recepción de FM estéreo aumenta, cancele el efecto de sonido surround.
D.Bass	Presione [D.BASS] durante la reproducción para seleccionar "ON D.BASS" o "OFF D.BASS".

- Puede experimentar una reducción de la calidad del sonido cuando se usan estos efectos con algunas fuentes. Si esto sucede, desactive los efectos de sonido.

Sincronizador

Ajuste del reloj

Éste es un reloj de 12 horas.

- 1 Presione [CLOCK/TIMER] para seleccionar "CLOCK".
- 2 En 10 segundos, presione [▲, ▼] para fijar la hora.
- 3 Presione [OK].



- Para visualizar el reloj, presione [CLOCK/TIMER].
- Vuelva a fijar el reloj regularmente para mantener la precisión.

Sincronizador de reproducción

Usted puede fijar el sincronizador para que se active a una hora determinada para despertarlo.

Esta unidad ofrece 3 sincronizadores opcionales de reproducción.

Preparación

- Encienda la unidad y fije el reloj (⇨ arriba).
- Prepare la fuente musical (disco, radio, iPod/iPhone o AUX) y fije el volumen.

- 1 Presione [CLOCK/TIMER] repetidamente para seleccionar "ⓄPLAY 1", "ⓄPLAY 2" o "ⓄPLAY 3".
- 2 En 10 segundos, presione [▲, ▼] para fijar la hora de inicio.
- 3 Presione [OK].
- 4 Fije la hora de finalización repitiendo los pasos 2 y 3.
- Para activar el sincronizador
- 5 Presione [PLAY, Ⓞ] repetidamente para activar el sincronizador de reproducción deseado.
- 6 Presione [⏻] para apagar la unidad.

Verificar las definiciones (Cuando la unidad está encendida o en modo standby)	Presione [CLOCK/TIMER] dos veces. (Se visualiza la definición.)
---	--

Cancelar	Presione [PLAY, Ⓞ] dos veces para cancelar el indicador del sincronizador del visor.
----------	--



- El sincronizador comenzará a la hora predefinida y el volumen aumentará gradualmente hasta el nivel predefinido.

Apagado automático

El apagado automático puede apagar la unidad después de una hora predefinida.

Presione [SLEEP] para activar o desactivar la función de apagado automático.

30MIN → 60MIN → 90MIN → 120MIN
↑ OFF (Cancelar) ←

Presione [SLEEP] una vez para verificar el tiempo restante.

- El sincronizador de reproducción y el apagado automático se pueden usar juntos. El apagado automático siempre tiene prioridad. Asegúrese de no superponer los ajustes del sincronizador.
- Cuando "AUTO OFF" está en "ON" y la unidad se deja sin usar durante aproximadamente 30 minutos, la unidad se apagará aun cuando no haya expirado el tiempo de reproducción o el de apagado automático.

Escuchar audio de un iPod o iPhone

Insertar/Extraer un iPod/iPhone

■ Insertar un iPod/iPhone

- 1 Abra la puerta deslizante. (⇒ 20)
- 2 Inserte el adaptador del conector apropiado (no provisto) para el iPod/iPhone.

- Inserte el lado del adaptador del conector del iPod/iPhone con los clips enfrentados hacia usted primero y luego empuje el lado opuesto hasta que quede bien calzado y haga clic.

- (A) Clips
- (B) Adaptador del conector
- (C) Palanca del interruptor de acoplamiento del iPod/iPhone
- (D) Conector

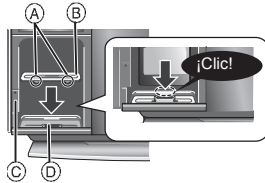

- 3 Presione [▲] para desbloquear el puerto de iPodR/iPhone y luego tire de la palanca del interruptor del puerto para inclinar el puerto de iPodR/iPhone.



- 4 Conecte el iPod/iPhone (no provisto) firmemente.

- Asegúrese de sacar el iPod/iPhone del estuche.

- 5 Empuje la palanca del interruptor del puerto hasta que haga clic en su sitio.

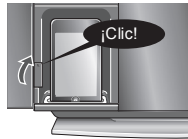

- 6 Cierre la puerta deslizante. (⇒ 20)

■ Extraer el iPod/iPhone

- ① Repita los pasos 1 y 3 (⇒ arriba).
- ② Para extraer, simplemente tire del iPod/iPhone hacia afuera.
- ③ Repita los pasos 5 y 6 (⇒ arriba).



- El conector del iPod/iPhone se puede dañar si no está inclinado cuando se conecta o desconecta el iPod/iPhone.
- Asegúrese de usar un adaptador del conector que sea compatible con su iPod/iPhone. Para comprar un adaptador del conector, consulte al distribuidor de iPod/iPhone.
- Reduzca el volumen de la unidad principal al mínimo antes de conectar o desconectar el iPod/iPhone.

Operaciones con el iPod

Preparación

Presione [iPod] (HC55: [0], iPod) repetidamente para seleccionar "IPOD".

Reproducir	Presione [▶/].
Pausa	Presione [▶/] o [■]. Presione nuevamente para reiniciar la reproducción.
Saltear pista	Presione [◀◀] o [▶▶].
Buscar la pista actual	Mantenga presionado [◀◀] o [▶▶].
Visualizar el menú iPod/iPhone/volver al menú anterior	Presione [iPod MENU] en modo de reproducción. (Mando a distancia solamente)
Seleccione los contenidos en el menú iPod/iPhone	Presione [▲, ▼] y luego [OK]. (Mando a distancia solamente)

■ iPod/iPhone compatibles (a junio de 2011)

La compatibilidad depende de la versión de software de su iPod/iPhone.

Nombre	Capacidad de memoria
iPod touch 4ta generación	8 GB, 32 GB, 64 GB
iPod nano 6ta generación	8 GB, 16 GB
iPod touch 3ra generación	32 GB, 64 GB
iPod nano 5ta generación (videocámara)	8 GB, 16 GB
iPod touch 2da generación	8 GB, 16 GB, 32 GB
iPod classic	120 GB, 160 GB (2009)
iPod nano 4ta generación (video)	8 GB, 16 GB
iPod classic	160 GB (2007)
iPod touch 1ra generación	8 GB, 16 GB, 32 GB
iPod nano 3ra generación (video)	4 GB, 8 GB
iPod classic	80 GB
iPod nano 2da generación (aluminio)	2 GB, 4 GB, 8 GB
iPod 5ta generación (video)	60 GB, 80 GB
iPod 5ta generación (video)	30 GB
iPod nano 1ra generación	1 GB, 2 GB, 4 GB
iPhone 4	16 GB, 32 GB
iPhone 3GS	8 GB, 16 GB, 32 GB
iPhone 3G	8 GB, 16 GB
iPhone	4 GB, 8 GB, 16 GB

- Según el modelo, puede ser necesario extraer el iPod/iPhone y seleccionar el álbum, artista, etc. en él.

HC55 Escuchar radio por Internet

Esta unidad puede reproducir radio por Internet si está instalado "vTuner for Panasonic" en su iPhone/iPod touch.

- Visite el sitio web que se indica a continuación para obtener más información sobre "vTuner for Panasonic": <http://radio.vtuner.com/panasonic/en/> (Modelos de iPhone/iPod touch sensibles al tacto y versiones de software compatibles, compra, instalación y funcionamiento.)

Preparación

Instale "vTuner for Panasonic" en su iPhone/iPod touch.

- 1 Inserte el iPhone/iPod touch en la unidad.
- 2 Presione [0, iPod] repetidamente para seleccionar "INTERNET RADIO". Se iniciará "vTuner for Panasonic".

HC55 Uso de un dispositivo compatible con Bluetooth

Operaciones con Bluetooth

Preparación

Sincronice el dispositivo Bluetooth a esta unidad para crear una conexión de audio.

- 1 Presione [0], iPod] repetidamente para seleccionar "BLUETOOTH".**
Cuando lo usa por primera vez, entra automáticamente en el modo de sincronización.
- 2 Mientras la unidad está en modo de sincronización, acceda al menú del dispositivo Bluetooth y ejecute la búsqueda de Bluetooth para encontrar esta unidad (SC-HC55).**
 - Consulte el manual del usuario del dispositivo Bluetooth para conocer más detalles sobre cómo conectar un dispositivo Bluetooth.
 - Si se le solicita la clave, ingrese "0000".
- 3 Si la sincronización es satisfactoria, se visualizará el nombre del dispositivo sincronizado durante 2 segundos. Se encenderá el indicador de Bluetooth. La unidad ahora está lista para usarse con el dispositivo Bluetooth.**



- Asegúrese de que el dispositivo Bluetooth soporte A2DP (Advance Audio Distribution Profile).
- Esta unidad soporta la recepción A2DP que está protegida por derechos de autor mediante el método SCMS-T.
- A2DP le permite reproducir sonido estéreo desde una fuente de audio (teléfono móvil, PC o laptop) en esta unidad a través del Bluetooth.
- Según la especificación o la configuración del teléfono móvil, la conexión puede no establecerse o el funcionamiento y la visualización pueden variar.
- Si registra más de la cantidad máxima de dispositivos, se sobregabará el dispositivo más viejo en la historia de conexiones.
- Si un dispositivo ya registrado se vuelve a registrar, se sobregabará.

Reproducción básica

Sincronice el dispositivo Bluetooth a esta unidad para crear una conexión de audio.

- 1 Presione [0], iPod] repetidamente para seleccionar "BLUETOOTH".**
- En el dispositivo Bluetooth:
Selecione esta unidad (SC-HC55) en la pantalla de configuración Bluetooth para hacer esta conexión.
- En el dispositivo Bluetooth:
Comience a reproducir música de una fuente
 - Si el dispositivo está conectado, la música se escuchará en esta unidad.
 - El indicador de Bluetooth se enciende cuando hay una conexión.
 - Si es necesario, consulte el manual del usuario del dispositivo Bluetooth.
- 4 También puede realizar los siguientes controles con el mando a distancia.**

Reproducir	Presione [▶/] para comenzar a reproducir.
Detención	Presione [■].
Pausa	Presione [▶/]. Presione nuevamente para reiniciar la reproducción.
Saltar pista	Presione [◀◀] o [▶▶].
Visualizar información	Presione [DISPLAY] repetidamente.



- Para usar estas funciones, el dispositivo Bluetooth debe soportar AVRCP (Audio Video Remote Control Profile).
- Esta unidad no puede transmitir datos al dispositivo Bluetooth.
- Cuando reproduce contenido del iPod/iPhone a través del Bluetooth con la unidad principal, se puede sentir un sonido intermitente si deja la pantalla del menú iPod/iPhone Bluetooth activa o cuando registra o conecta el Bluetooth. Si esto ocurre, salga de la pantalla del menú iPod/iPhone Bluetooth.
- Cuando reproduce música del iPod/iPhone a través de una conexión Bluetooth y el iPod/iPhone está conectado al conector de iPod/iPhone de esta unidad, el audio no será reproducido mientras está seleccionado "BLUETOOTH". Seleccione "IPOD" para seguir escuchando la música.

Hands-Free Profile (HFP)

Esta unidad funciona como un Bluetooth manos libres para su teléfono móvil.

Para responder una llamada ("IN CALL" parpadea)	Presione [↵]. "CALLING" comienza a parpadear en el visor (hable en el micrófono de la unidad). Presione [↵] nuevamente para transferir la llamada al teléfono móvil ("TRANSFER" parpadea. Ahora puede conversar usando el teléfono móvil).
Para cancelar una llamada	Presione [✕].
Para ajustar el volumen del sonido	Presione [+ , VOL , -] (regulable de "TEL VOL 1" a "TEL VOL 10").
Para silenciar el micrófono	Presione [MUTE]. Presione nuevamente para cancelar. (Durante "MIC MUTE", la persona que llama no puede escuchar su voz).



- Esta unidad no funciona con Headset Profile (HSP).
- Cuando el teléfono móvil está demasiado cerca del micrófono de esta unidad, se puede escuchar ruido. Cuando hace una llamada mantenga siempre el teléfono alejado del micrófono de esta unidad.
- El audio de un disco se detendrá cuando llama en modo manos libres.

Desconectar el dispositivo Bluetooth

- 1 Presione [0], iPod] repetidamente para seleccionar "BLUETOOTH".**
- 2 Presione [0 MENU] para visualizar "DISCONNECT?" y luego presione [OK].**
Se visualizará un mensaje de confirmación.
- 3 Presione [◀, ▶] para seleccionar "YES" y luego presione [OK].**



- La conexión también se puede detener cuando desactiva la transmisión Bluetooth en el dispositivo Bluetooth conectado.



Horizontal lines for text entry, partially obscured by a black redaction box on the right side.

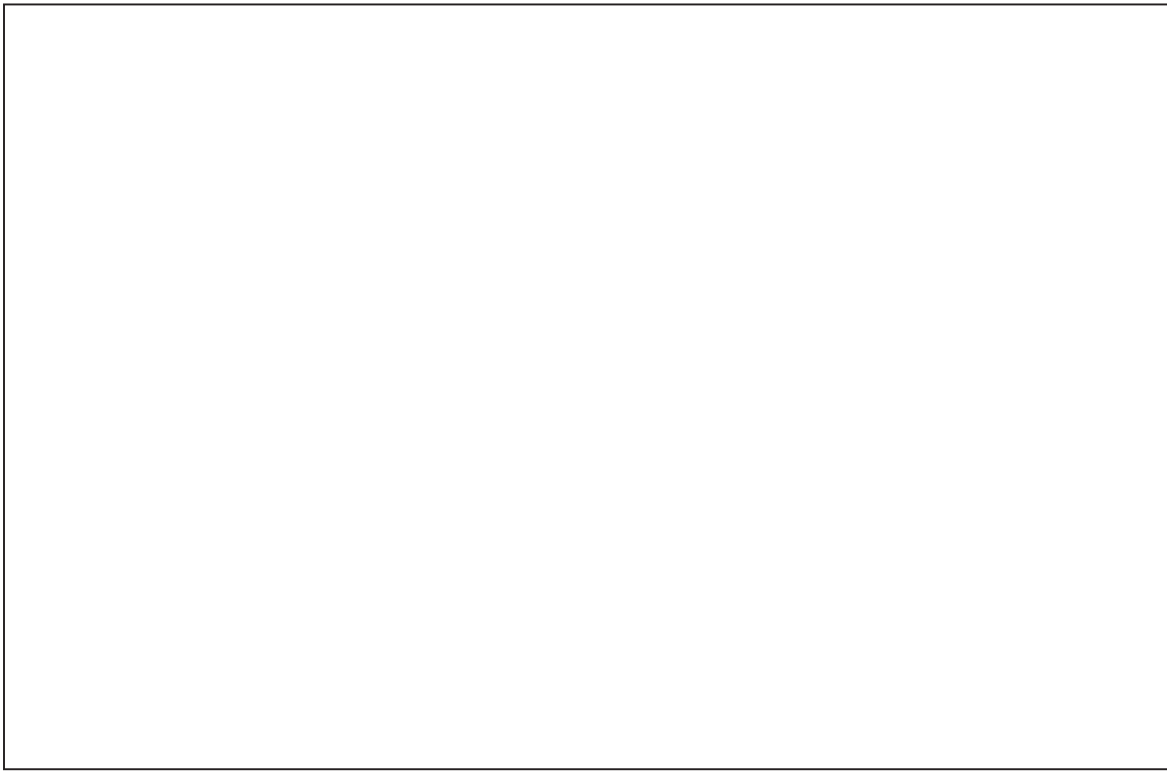
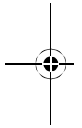

Limited Warranty (ONLY FOR U.S.A. AND PUERTO RICO)

Panasonic Consumer Electronics Company,
Division of Panasonic Corporation of North America
One Panasonic Way, Secaucus, New Jersey 07094

Panasonic Home Audio Products Limited Warranty

Limited Warranty Coverage (For USA and Puerto Rico Only)

If your product does not work properly because of a defect in materials or workmanship, Panasonic Consumer Electronics Company (referred to as "the warrantor") will, for the length of the period indicated on the chart below, which starts with the date of original purchase ("warranty period"), at its option either (a) repair your product with new or refurbished parts, (b) replace it with a new or a refurbished equivalent value product, or (c) refund your purchase price. The decision to repair, replace or refund will be made by the warrantor.

Product or Part Name	Parts	Labor
Audio Products (except items below)	1 year	1 year
DVD Home Theater System	1 year	1 year
Home Theater Audio System	1 year	1 year
USB Reader-writer, PC Card Adapters (defective exchange)	1 year	Not Applicable
Accessories: Headphones, cartridges, Microphones, Adapters	90 days	90 days
Rechargeable Batteries, DVD-RAM Disc (defective exchange)	10 days	Not Applicable
SD Memory Cards, Rechargeable Battery Packs (defective exchange)	90 days	Not Applicable

During the "Labor" warranty period there will be no charge for labor. During the "Parts" warranty period, there will be no charge for parts. This Limited Warranty excludes both parts and labor for non-rechargeable batteries, antennas, and cosmetic parts (cabinet). This warranty only applies to products purchased and serviced in the United States or Puerto Rico. This warranty is extended only to the original purchaser of a new product which was not sold "as is".

Carry-In or Mail-In Service

To find a service center please visit <http://www.panasonic.com/help> or call 1-800-211-PANA (7262).

When shipping the unit, carefully pack, include all accessories, and send it prepaid, adequately insured and preferably in the original carton. When shipping Lithium Ion batteries please visit our Web Site at www.panasonic.com/BatteryHandling as Panasonic is committed to providing the most up to date information. Include a letter detailing the complaint, a return address and provide a daytime phone number where you can be reached. A valid registered receipt is required under the Limited Warranty.

IF REPAIR IS NEEDED DURING THE WARRANTY PERIOD, THE PURCHASER WILL BE REQUIRED TO FURNISH A SALES RECEIPT/ PROOF OF PURCHASE INDICATING DATE OF PURCHASE, AMOUNT PAID AND PLACE OF PURCHASE. CUSTOMER WILL BE CHARGED FOR THE REPAIR OF ANY UNIT RECEIVED WITHOUT SUCH PROOF OF PURCHASE.

Limited Warranty Limits And Exclusions

This warranty ONLY COVERS failures due to defects in materials or workmanship, and DOES NOT COVER normal wear and tear or cosmetic damage. The warranty ALSO DOES NOT COVER damages which occurred in shipment, or failures which are caused by products not supplied by the warrantor, or failures which result from accidents, misuse, abuse, neglect, mishandling, misapplication, alteration, faulty installation, set-up adjustments, misadjustment of consumer controls, improper maintenance, power line surge, lightning damage, modification, introduction of sand, humidity or liquids, commercial use such as hotel, office, restaurant, or other business or rental use of the product, or service by anyone other than a Factory Service Center or other Authorized Servicer, or damage that is attributable to acts of God.

THERE ARE NO EXPRESS WARRANTIES EXCEPT AS LISTED UNDER "LIMITED WARRANTY COVERAGE". THE WARRANTOR IS NOT LIABLE FOR INCIDENTAL OR CONSEQUENTIAL DAMAGES RESULTING FROM THE USE OF THIS PRODUCT, OR ARISING OUT OF ANY BREACH OF THIS WARRANTY. (As examples, this excludes damages for lost time, travel to and from the servicer, loss of or damage to media or images, data or other memory or recorded content. The items listed are not exclusive, but for illustration only.) **ALL EXPRESS AND IMPLIED WARRANTIES, INCLUDING THE WARRANTY OF MERCHANTABILITY, ARE LIMITED TO THE PERIOD OF THE LIMITED WARRANTY.**

Some states do not allow the exclusion or limitation of incidental or consequential damages, or limitations on how long an implied warranty lasts, so the exclusions may not apply to you.

This warranty gives you specific legal rights and you may also have other rights which vary from state to state. If a problem with this product develops during or after the warranty period, you may contact your dealer or Service Center. If the problem is not handled to your satisfaction, then write to the warrantor's Consumer Affairs Department at the addresses listed for the warrantor.

PARTS AND SERVICE, WHICH ARE NOT COVERED BY THIS LIMITED WARRANTY, ARE YOUR RESPONSIBILITY.

Customer Services Directory (United States and Puerto Rico)

Obtain Product Information and Operating Assistance; locate your nearest Dealer or Service Center; purchase Parts and Accessories; or make Customer Service and Literature requests by visiting our Web Site at:

<http://www.panasonic.com/help>

or, contact us via the web at:

<http://www.panasonic.com/contactinfo>

You may also contact us directly at:

1-800-211-PANA (7262)

Monday-Friday 9am-9pm,

Saturday-Sunday 10am-7pm EST

**For hearing or speech impaired TTY users, TTY:
1-877-833-8855**

Accessory Purchases (United States and Puerto Rico)

Purchase Parts, Accessories and Instruction Books online for all Panasonic Products by visiting our Web Site at:

<http://www.pstc.panasonic.com>

Or, send your request by E-mail to:

npcparts@us.panasonic.com

You may also contact us directly at:

1-800-332-5368 (Phone) 1-800-237-9080 (Fax Only)

(Monday-Friday 9am-9pm EST)

Panasonic Service and Technology Company

20421 84th Avenue South, Kent, WA 98032

(We accept Visa, MasterCard, Discover Card, American Express, and Personal Checks)

**For hearing or speech impaired TTY users, TTY:
1-866-605-1277**

As of December 2010

Limited Warranty (ONLY FOR CANADA)

Panasonic Canada Inc.
5770 Ambler Drive, Mississauga, Ontario L4W 2T3

PANASONIC PRODUCT - LIMITED WARRANTY EXCHANGE PROGRAM

Panasonic Canada Inc. warrants this product to be free from defects in material and workmanship under normal use and for a period as stated below from the date of original purchase agrees to, at its option either (a) repair your product with new or refurbished parts, (b) replace it with a new or a refurbished equivalent value product, or (c) refund your purchase price. The decision to repair, replace or refund will be made by Panasonic Canada Inc.

Panasonic Portable / Clock Radio (without Tape, CD, MD)	One (1) year
Panasonic Audio Product	One (1) year
Panasonic DVD Product	One (1) year
Accessories including rechargeable batteries	Ninety (90) days

This warranty is given only to the original purchaser, or the person for whom it was purchased as a gift, of a Panasonic brand product mentioned above sold by an authorized Panasonic dealer in Canada and purchased and used in Canada, which product was not sold "as is", and which product was delivered to you in new condition in the original packaging.

IN ORDER TO BE ELIGIBLE TO RECEIVE WARRANTY SERVICE HEREUNDER, A PURCHASE RECEIPT OR OTHER PROOF OF DATE OF ORIGINAL PURCHASE, SHOWING AMOUNT PAID AND PLACE OF PURCHASE IS REQUIRED

LIMITATIONS AND EXCLUSIONS

This warranty ONLY COVERS failures due to defects in materials or workmanship, and DOES NOT COVER normal wear and tear or cosmetic damage. The warranty ALSO DOES NOT COVER damages which occurred in shipment, or failures which are caused by products not supplied by Panasonic Canada Inc., or failures which result from accidents, misuse, abuse, neglect, mishandling, misapplication, alteration, faulty installation, set-up adjustments, misadjustment of consumer controls, improper maintenance, power line surge, lightning damage, modification, introduction of sand, humidity or liquids, commercial use such as hotel, office, restaurant, or other business or rental use of the product, or service by anyone other than an Authorized Servicer, or damage that is attributable to acts of God.

Dry cell batteries are also excluded from coverage under this warranty.

THIS EXPRESS, LIMITED WARRANTY IS IN LIEU OF ALL OTHER WARRANTIES, EXPRESS OR IMPLIED, INCLUDING ANY IMPLIED WARRANTIES OF MERCHANTABILITY AND FITNESS FOR A PARTICULAR PURPOSE. IN NO EVENT WILL PANASONIC CANADA INC. BE LIABLE FOR ANY SPECIAL, INDIRECT OR CONSEQUENTIAL DAMAGES RESULTING FROM THE USE OF THIS PRODUCT OR ARISING OUT OF ANY BREACH OF ANY EXPRESS OR IMPLIED WARRANTY. (As examples, this warranty excludes damages for lost time, travel to and from the Authorized Servicer, loss of or damage to media or images, data or other memory or recorded content. This list of items is not exhaustive, but for illustration only.)

In certain instances, some jurisdictions do not allow the exclusion or limitation of incidental or consequential damages, or the exclusion of implied warranties, so the above limitations and exclusions may not be applicable. This warranty gives you specific legal rights and you may have other rights which vary depending on your province or territory.

CONTACT INFORMATION

For product information and operation assistance, please contact:

Our Customer Care Centre: Telephone #: 1-800-561-5505
Fax #: (905) 238-2360
Email link: "Support → contact us → email" on www.panasonic.ca

For defective product exchange within the warranty period, please contact the original dealer or our Customer Care Centre.

HC55

THE FOLLOWING APPLIES ONLY IN THE U.S.A.

FCC Note:

This equipment has been tested and found to comply with the limits for a Class B digital device, pursuant to Part 15 of the FCC Rules. These limits are designed to provide reasonable protection against harmful interference in a residential installation. This equipment generates, uses, and can radiate radio frequency energy and, if not installed and used in accordance with the instructions, may cause harmful interference to radio communications.

However, there is no guarantee that interference will not occur in a particular installation. If this equipment does cause harmful interference to radio or television reception, which can be determined by turning the equipment off and on, the user is encouraged to try to correct the interference by one or more of the following measures:

- Reorient or relocate the receiving antenna.
- Increase the separation between the equipment and receiver.
- Connect the equipment into an outlet on a circuit different from that to which the receiver is connected.
- Consult the dealer or an experienced radio/TV technician for help.

FCC caution: To maintain compliance with FCC regulations, shielded interface cables must be used with this equipment. Operation with non-approved equipment or unshielded cables may result in interference to radio and TV reception. Any changes or modifications not approved by the party responsible for compliance could void the user's authority to operate this equipment.

This device complies with Part 15 of the FCC Rules.

Operation is subject to the following two conditions:

- (1) This device may not cause harmful interference, and
- (2) this device must accept any interference received, including interference that may cause undesired operation.

Responsible Party:

Panasonic Corporation of North America
One Panasonic Way
Secaucus, NJ 07094

Support Contact:

Panasonic Consumer Electronics Company
Telephone No.: 1-800-211-PANA (7262)



WARNING:

To satisfy FCC RF exposure requirements for mobile transmitting devices, a separation distance of 20 cm (7 7/8") or more should be maintained between the antenna of this device and persons during device operation. To ensure compliance, operations at closer than this distance is not recommended. The antenna used for this transmitter must not be co-located in conjunction with any other antenna or transmitter.

HC35

THE FOLLOWING APPLIES ONLY IN THE U.S.A.

FCC Note:

This equipment has been tested and found to comply with the limits for a Class B digital device, pursuant to Part 15 of the FCC Rules.

These limits are designed to provide reasonable protection against harmful interference in a residential installation. This equipment generates, uses and can radiate radio frequency energy and, if not installed and used in accordance with the instructions, may cause harmful interference to radio communications. However, there is no guarantee that interference will not occur in a particular installation. If this equipment does cause harmful interference to radio or television reception, which can be determined by turning the equipment off and on, the user is encouraged to try to correct the interference by one or more of the following measures:

- Reorient or relocate the receiving antenna.
- Increase the separation between the equipment and receiver.
- Connect the equipment into an outlet on a circuit different from that to which the receiver is connected.
- Consult the dealer or an experienced radio/TV technician for help.

Any unauthorized changes or modifications to this equipment would void the user's authority to operate this device.

This device complies with Part 15 of the FCC Rules. Operation is subject to the following two conditions: (1) This device may not cause harmful interference, and (2) this device must accept any interference received, including interference that may cause undesired operation.

Responsible Party:

Panasonic Corporation of North America
One Panasonic Way
Secaucus, NJ 07094

Support Contact:

Panasonic Consumer Electronics Company
Telephone No.: 1-800-211-PANA (7262)



As an ENERGY STAR® Partner,* Panasonic has determined that this product meets the ENERGY STAR® guidelines for energy efficiency.

*For Canada only: The word "Participant" is used in place of the word "Partner".

For SC-HC55 only



For U.S.A. and Puerto Rico
Panasonic Consumer Electronics Company,
Division of Panasonic Corporation of North America
One Panasonic Way, Secaucus,
New Jersey 07094
<http://www.panasonic.com>

For Canada
Panasonic Canada Inc.
5770 Ambler Drive
Mississauga, Ontario
L4W 2T3
www.panasonic.ca

