

## Owner's Manual Compact Stereo System

Model No. SC-HC38

ENGLISH

ESPAÑOL



Thank you for purchasing this product.  
Please read these instructions carefully before using this product,  
and save this manual for future use.

If you have any questions, contact: 1-800-211-PANA (7262)

Register online at [www.panasonic.com/register](http://www.panasonic.com/register) (U.S. customers only)

### **Included Installation Instructions (→ 2, 3 and 16, 17)**

**The installation work should be done by a qualified installation specialist.**

Before commencing work, carefully read these installation instructions and the operating instructions to ensure that installation is performed correctly.

(Please keep these instructions. You may need them when maintaining or moving this unit.)

La referencia rápida en español se puede encontrar en la página 18.

# IMPORTANT SAFETY INSTRUCTIONS

Read these operating instructions carefully before using the unit. Follow the safety instructions on the unit and the applicable safety instructions listed below. Keep these operating instructions handy for future reference.

- 1 Read these instructions.
- 2 Keep these instructions.
- 3 Heed all warnings.
- 4 Follow all instructions.
- 5 Do not use this apparatus near water.
- 6 Clean only with dry cloth.
- 7 Do not block any ventilation openings. Install in accordance with the manufacturer's instructions.
- 8 Do not install near any heat sources such as radiators, heat registers, stoves, or other apparatus (including amplifiers) that produce heat.
- 9 Do not defeat the safety purpose of the polarized or grounding-type plug. A polarized plug has two blades with one wider than the other. A grounding-type plug has two blades and a third grounding prong. The wide blade or the third prong are provided for your safety. If the provided plug does not fit into your outlet, consult an electrician for replacement of the obsolete outlet.
- 10 Protect the power cord from being walked on or pinched particularly at plugs, convenience receptacles, and the point where they exit from the apparatus.
- 11 Only use attachments/accessories specified by the manufacturer.
- 12 Use only with the cart, stand, tripod, bracket, or table specified by the manufacturer, or sold with the apparatus. When a cart is used, use caution when moving the cart/apparatus combination to avoid injury from tip-over.
- 13 Unplug this apparatus during lightning storms or when unused for long periods of time.
- 14 Refer all servicing to qualified service personnel. Servicing is required when the apparatus has been damaged in any way, such as power-supply cord or plug is damaged, liquid has been spilled or objects have fallen into the apparatus, the apparatus has been exposed to rain or moisture, does not operate normally, or has been dropped.



## -If you see this symbol-

### Information on Disposal in other Countries outside the European Union



This symbol is only valid in the European Union.

If you wish to discard this product, please contact your local authorities or dealer and ask for the correct method of disposal.

## WARNING

### Unit

- To reduce the risk of fire, electric shock or product damage,
  - Do not expose this unit to rain, moisture, dripping or splashing.
  - Do not place objects filled with liquids, such as vases, on this unit.
  - Use only the recommended accessories.
  - Do not remove covers.
  - Do not repair this unit by yourself. Refer servicing to qualified service personnel.

### AC power supply cord

- The power plug is the disconnecting device. Install this unit so that the power plug can be unplugged from the socket outlet immediately.

### Button-type battery (Lithium battery)

- Risk of fire, explosion and burns. Do not disassemble, heat above 60 °C (140 °F) or incinerate.



### DO NOT INGEST BATTERY, CHEMICAL BURN HAZARD

This product contains a coin/button cell battery. If the coin/button cell battery is swallowed, it can cause severe internal burns in just 2 hours and can lead to death. Keep new and used batteries away from children. If the battery compartment does not close securely, stop using the product and keep it away from children. If you think batteries might have been swallowed or placed inside any part of the body, seek immediate medical attention.

If any electrolyte should come into contact with your hands or clothes, wash it off thoroughly with water. If any electrolyte should come into contact with your eyes, never rub the eyes. Rinse eyes thoroughly with water, and then consult a doctor.

<For USA-California only>

This product contains a CR Coin Cell Lithium Battery which contains Perchlorate Material – special handling may apply.  
See [www.dtsc.ca.gov/hazardouswaste/perchlorate](http://www.dtsc.ca.gov/hazardouswaste/perchlorate).

CAUTION - VISIBLE AND  
INVISIBLE LASER RADIATION  
WHEN OPEN AND  
INTERLOCK DEFEATED.  
DO NOT STARE INTO BEAM.  
FDA 21CFR / CLASS II (IIa) RGL50475

(Inside of product)

**CAUTION**

**Unit**

- This unit utilizes a laser. Use of controls or adjustments or performance of procedures other than those specified herein may result in hazardous radiation exposure.
- Do not place sources of naked flames, such as lighted candles, on this unit.

**Placement**

- To reduce the risk of fire, electric shock or product damage,
  - Do not install or place this unit in a bookcase, built-in cabinet or in another confined space. Ensure this unit is well ventilated.
  - Do not obstruct this unit's ventilation openings with newspapers, tablecloths, curtains, and similar items.

**Button-type battery (Lithium battery)**

- Danger of explosion if battery is incorrectly replaced. Replace only with the type recommended by the manufacturer.
- Keep out of reach of children.
- Insert with poles aligned.
- Mishandling of batteries can cause electrolyte leakage and may cause a fire.
  - Remove batteries if you do not intend to use the remote control for a long period of time. Store in a cool, dark place.
  - Do not heat or expose to flame.
  - Do not leave the battery(ies) in a car exposed to direct sunlight for a long period of time with doors and windows closed.
  - Do not touch the terminals (+ and -) with metal objects.
  - Do not recharge, disassemble, remodel, heat or throw into fire.
- When disposing the batteries, please contact your local authorities or dealer and ask for the correct method of disposal.

**Table of contents**

**IMPORTANT SAFETY INSTRUCTIONS**..... 2

**Accessories** ..... 3

**Control reference guide**..... 4

**Connections** ..... 5

**Unit and media care** ..... 5

**Inserting media**..... 6

**Bluetooth® operations** ..... 7

**Media playback operations** ..... 8

**Listening to the radio**..... 9

**Sound adjustment**..... 10

**Clock and Timer** ..... 10

**Others**..... 11

**Troubleshooting** ..... 11

**Licenses**..... 13

**Playable media** ..... 14

**About Bluetooth®** ..... 14

**Specifications** ..... 15

**Attaching the unit to a wall (optional)** ..... 16

**Spanish Quick Reference / Referencia rápida en español** ..... 18

**Limited Warranty (ONLY FOR U.S.A. AND PUERTO RICO)**..... 19

**About descriptions in this Owner's Manual**

- Pages to be referred to are indicated as "→ ○○"





**CAUTION**

**RISK OF ELECTRIC SHOCK  
DO NOT OPEN**



CAUTION : TO REDUCE THE RISK OF ELECTRIC SHOCK, DO NOT REMOVE SCREWS. NO USER-SERVICEABLE PARTS INSIDE. REFER SERVICING TO QUALIFIED SERVICE PERSONNEL

-  The lightning flash with arrowhead symbol, within an equilateral triangle, is intended to alert the user to the presence of uninsulated "dangerous voltage" within the product's enclosure that may be of sufficient magnitude to constitute a risk of electric shock to persons.
-  The exclamation point within an equilateral triangle is intended to alert the user to the presence of important operating and maintenance (servicing) instructions in the literature accompanying the appliance.

Product Identification Marking is located on the bottom of the unit.

**Accessories**

Check the supplied accessories before using this unit.

- 1 Remote control (with a battery)** (N2QAYC000082)
- 1 FM indoor antenna** (RSAX0002)
- 1 AC power supply cord** (K2CB2CB00022)



**Wall mounting accessories**

- 1 Safety holder** (RGQ0660-K)
- 2 Wall mount brackets** (RMQX1082-S)
- 1 Screw** (XTB3+8JFJK)

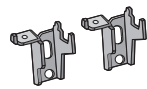

- Do not use AC power supply cord with other equipment.
- Product numbers provided in this Owner's Manual are correct as of December 2012. These may be subject to change.



# Connections

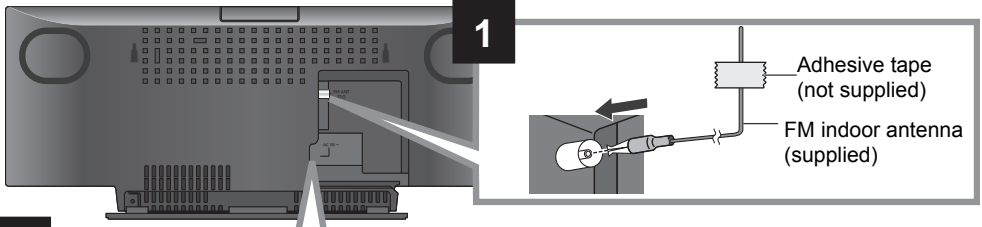

## **2** Connect the AC power supply cord after all other connections are completed.

This unit consumes a small amount of AC power (→ 15) even when turned off.

- In the interest of power conservation, if you will not be using this unit for an extended period of time, unplug it from the household AC outlet.

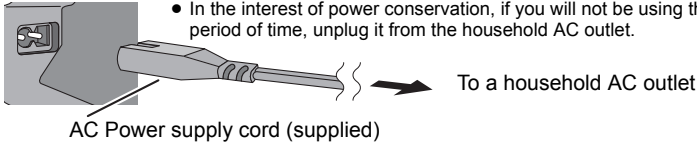

- These speakers do not have magnetic shielding. Do not place them near a television, personal computer or other devices easily influenced by magnetism.
- Tape the antenna to a wall or column in a position with the least amount of interference. (Use an FM outdoor antenna if radio reception is poor.)

## Unit and media care

Pull out the AC power plug from the outlet before maintenance.

### ■ Clean this unit with a soft, dry cloth

- When dirt is heavy, wring a cloth moistened in water tightly to wipe the dirt, and then wipe it with a dry cloth.
- Never use alcohol, paint thinner or benzine to clean this unit.
- Before using chemically treated cloth, carefully read the instructions that came with the cloth.

### ■ Maintenance of the lens

- Clean the lens regularly to prevent malfunctions. Use a blower to remove dust and a cotton swab if it is extremely dirty.
- You cannot use a CD type lens cleaner.
- Do not leave the sliding door open for prolonged periods of time. This will cause the lens to get dirty.
- Be careful not to touch the lens with your fingers.

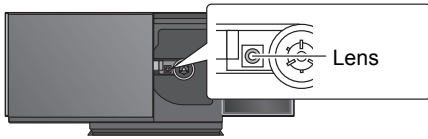

### ■ Clean discs

DO

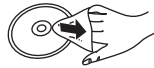

Wipe with a damp cloth and then wipe dry.

DO NOT



### ■ Disc handling precautions

- Handle discs by the edges to avoid inadvertent scratches or fingerprints on the disc.
- Do not attach labels or stickers to discs.
- Do not use record cleaning sprays, benzine, thinner, static electricity prevention liquids or any other solvent.
- Do not use the following discs:
  - Discs with exposed adhesive from removed stickers or labels (rented discs etc.).
  - Discs that are badly warped or cracked.
  - Irregularly shaped discs, such as heart shapes.

### ■ To dispose or transfer this unit

The unit may keep the user settings information in the unit. If you discard this unit either by disposal or transfer, then follow the procedure to return all the settings to the factory presets to delete the user settings. (→ 11, "To return all settings to the factory preset")

- The operation history may be recorded in the memory of this unit.

# Inserting media

## Select "IPOD\_PORT" as the source

Connect using the dedicated USB cable (not supplied) \*1, 2

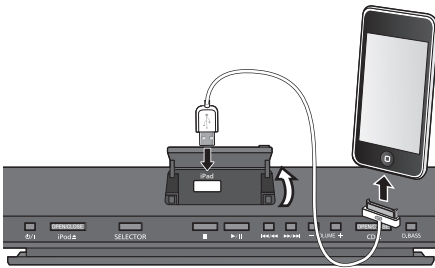

## Select "CD" as the source

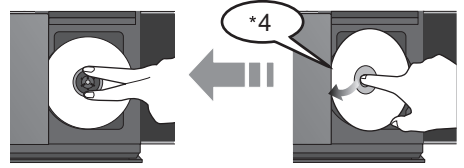

## Select "IPOD\_DOCK" as the source

Connect Lightning connector models \*1

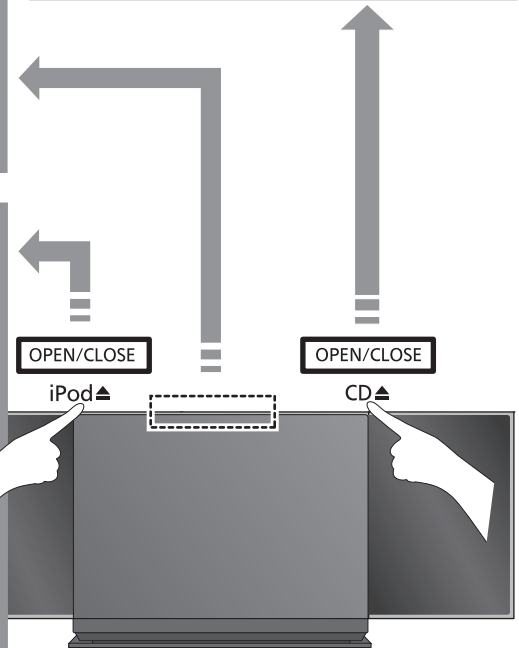
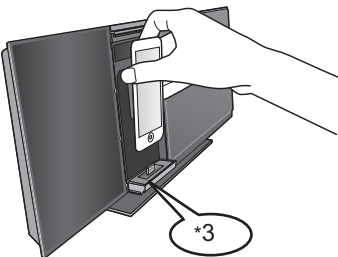

\*1: Refer to "Playable media" for compatible models. (→ 14)

\*2: Do not connect the following models to this unit's iPod port:

- iPod classic®, iPod [4th (color display), and 5th (video) generation]
- Unexpected behavior may occur.

\*3: When using the Lightning connector:

- Be sure to remove the iPod/iPhone from its case.
- Do not push or pull the dock manually.
- Make sure that the iPod/iPhone is fully inserted and its back is resting against the cushion pad.
- Make sure to hold the dock when removing the iPod/iPhone.

\*4: Make sure to tilt the disc so as not to touch the sliding door.

- Do not open the sliding door manually.
- Make sure that the unit does not fall when inserting or removing media.
- When moving this unit, be sure to remove all media and turn this unit to standby mode.

## Charging an iPod/iPhone/iPad

Charging starts when an iPod\*/iPhone/iPad is connected to this unit.

- During standby mode, charging will not start from the USB cable connection, however it will start as usual from the Lightning connector.
  - To charge from the USB cable connection, start the charging before turning this unit to standby mode.



- Check the iPod/iPhone/iPad to see if the battery is fully charged. (Once fully recharged, additional recharging will not occur.)
- If this unit is switched to standby mode "IPOD CHARGING" is shown on the unit's display.



# Media playback operations







The following marks indicate the availability of the feature.

- CD** : CD audio in CD-DA format
- iPod** : Compatible iPod/iPhone/iPad (→ 14)
- Bluetooth** : Connected Bluetooth® device (→ 7)

## Preparation

- Turn the unit on.
- Insert the media (→ 6) or connect the Bluetooth® device (→ 7).
- Press [CD], [iPod] or [] to select the audio source.

## Basic play (**CD**, **iPod**, **Bluetooth**)

Play	Press [  /  ].
Stop	Press [  ].
Pause	Press [  /  ]. Press again to restart play.
Skip	Press [  /  ] or [  /  ] to skip track.
Search	During play or pause Press and hold [  /  ] or [  /  ]. <ul style="list-style-type: none"><li>• <b>iPod</b> : Backwards search is only within the current track.</li></ul>



## **CD** **Bluetooth** To display information

Press [DISPLAY] repeatedly.



- To use this unit's remote control with a Bluetooth® device, the Bluetooth® device must support AVRCP (Audio Video Remote Control Profile). Depending on the device or the status of the device, some operations may not work.

## **iPod** To navigate through the iPod/iPhone menu



- Open the Music App to use this feature with iPod touch®/iPhone.
- [, ]: To navigate menu items.
- [OK]: To go to the next menu.
- [iPod MENU]: To return to the previous menu.



- To view the operation, open the sliding door.
- The operation may vary among iPod/iPhone/iPad models.
- Depending on the model, it may be necessary to select the album, artist, etc. on the iPod/iPhone/iPad.

## Playback modes (**CD**)

Select the playback mode.

- 1 Press [PLAY MENU] to select "PLAYMODE" or "REPEAT".
- 2 Press [, ] to select the setting and then press [OK].

### PLAYMODE

OFF PLAYMODE	Select to cancel the play mode setting.
1-TRACK	Only plays the selected track. <ul style="list-style-type: none"><li>• "1, 2" is displayed. (Skip to the desired track)</li></ul>
RANDOM	Plays the contents randomly. <ul style="list-style-type: none"><li>• "RND" is displayed.</li></ul>

### REPEAT

ON REPEAT	Turn on repeat mode. <ul style="list-style-type: none"><li>• " " is displayed.</li></ul>
OFF REPEAT	Turn off repeat mode.



- When using an iPod/iPhone/iPad or Bluetooth® device, use the setting on the device, if available.
- During random play, you cannot skip to the previous track.
- The mode is canceled when you open the sliding door for discs.



# Listening to the radio

You can preset up to 30 channels.

## Preparation

- Make sure that the FM antenna is connected. (→ 5)
- Turn the unit on.
- Press [RADIO] to select "FM".



A station previously stored is overwritten when another station is stored in the same channel preset.

## Presetting stations automatically

- 1 Press [PLAY MENU] to select "A.PRESET".
- 2 Press [▲, ▼] to select "LOWEST" or "CURRENT" and then press [OK].

### LOWEST:

To begin auto preset with the lowest frequency (FM 87.9 or FM 87.5).

### CURRENT:

To begin auto preset with the current frequency.\*

\* To change the frequency, refer to "Manual tuning and presetting".

The tuner starts to preset all the stations it can receive into the channels in ascending order.

## Listening to a preset channel

### Preparation

- 1 Press [PLAY MENU] repeatedly to select "TUNEMODE".
- 2 Press [▲, ▼] to select "PRESET" and then press [OK].

Press [◀◀/▶▶] or [▶▶/▶▶] to select the channel.

## Manual tuning and presetting

Select a radio broadcast.

- 1 Press [PLAY MENU] repeatedly to select "TUNEMODE".
- 2 Press [▲, ▼] to select "MANUAL" and then press [OK].
- 3 Press [◀◀/▶▶] or [▶▶/▶▶] to tune to the required station.

- To start automatic tuning, press and hold [◀◀/▶▶], [▶▶/▶▶] until the frequency starts scrolling. Tuning stops when a station is found.

To preset the channel

- 4 While listening to the radio broadcast Press [OK].
- 5 Press [▲, ▼] to select the channel and then press [OK].

## To improve FM sound quality

- 1 While receiving FM broadcasts, press [PLAY MENU] repeatedly to select "FM MODE".
- 2 Press [▲, ▼] to select "MONO" and then press [OK].

- This setting can be preset and memorized. To do so, continue to step 4 of "Manual tuning and presetting".



- Select "STEREO" in step 2 to return to stereo broadcasts.
- "MONO" is canceled if the frequency is changed.
- If "MONO" is selected, regardless of the type of signal this unit is receiving, "FM MONO" is displayed when [DISPLAY] is pressed. (→ below)

## To display the current signal status

Press [DISPLAY].

"FM ST": The FM signal is in stereo.

"FM": The FM signal is in monaural.

- "FM" is also displayed even if this unit is not tuned to a station.



- "STEREO" is displayed when this unit tunes to a stereo broadcast.



# Others

## Automatic standby

As a factory preset, this unit will always turn off automatically if there is no sound output and no operation for approx. 30 minutes.

**To cancel this function**

- 1 Press [SETUP] repeatedly to select "AUTO OFF".
- 2 Press [▲, ▼] to select "OFF" and then press [OK].



- To turn automatic standby on, select "ON" in step 2.
- This setting cannot be selected when "FM" is the source.

## Display brightness

The brightness of this unit's display can be changed.

- 1 Press [SETUP] repeatedly to select "DIMMER".
- 2 Press [▲, ▼] to select "ON" and then press [OK].



To cancel the dimmer, select "OFF" in step 2.

## Changing the unit and remote control code

When other Panasonic equipment responds to the supplied remote control, change the remote control code.

- 1 Press [CD] to select "CD".
- 2 While pressing and holding [SELECTOR] on the unit, press and hold [CD/RADIO] on the remote control until the unit's display shows "REMOTE 2".
- 3 Press and hold [OK] and [CD/RADIO] on the remote control for at least 4 seconds.



- To change the mode back to "REMOTE 1", repeat the steps above but replace the button pressed on the remote control from [CD/RADIO] to [⊗].

# Troubleshooting

Before requesting service, make the following checks. If you are in doubt about some of the check points, or if the solutions indicated in the following guide do not solve the problem, refer to "Customer Services Directory (United States and Puerto Rico)" on page 19.

## To return all settings to the factory preset

When the following situations occur, reset the memory:

- There is no response when buttons are pressed.
- You want to clear and reset the memory contents.

- ① Disconnect the AC power supply cord. (Wait for at least 3 minutes before proceeding to step ②.)
- ② While pressing and holding down [⏻/I] on the unit, reconnect the AC power supply cord.
  - "-----" appears on the display.
- ③ Release [⏻/I].



All the settings are returned to the factory preset. You will need to reset the memory items.

## Common problems

### Humming heard during play.

- An AC power supply cord or fluorescent light is near the cords. Keep other appliances and cords away from this unit's cables.

## Disc operations

### Incorrect display or play will not start.

- Make sure that the disc is compatible with this unit. (→ 14)
- There is moisture on the lens. Wait for about an hour and then try again.

## Radio

### A beat sound or noise is heard while receiving radio broadcast.

- Confirm the FM antenna is properly connected. (→ 5)
- Adjust the position of the antenna.
- Try to keep a certain amount of distance between the antenna and AC power supply cord.
- Try using an outdoor antenna if there are buildings or mountains nearby.
- Switch the television or other audio players off or separate it from this unit.
- Keep this unit away from mobile phones if the interference is apparent.

## Stations cannot be selected.

Change the FM frequency step.

- ① Press [RADIO] to select "FM".
- ② Press and hold [SELECTOR] on the unit.

After a few seconds the display changes to show the current lowest frequency. Continue to hold the button down. The lowest frequency changes and the step is changed.

## iPod/iPhone/iPad operations

### Cannot charge or operate.

- Have you selected the appropriate selector? Press [iPod] to select either "IPOD\_DOCK" or "IPOD\_PORT".
- Check that the iPod/iPhone/iPad is connected properly. (→ 6)
- The battery of the iPod/iPhone/iPad is depleted. Charge the iPod/iPhone/iPad, and then operate again.
- Connect the iPod/iPhone/iPad again or try to restart the iPod/iPhone/iPad.
- When this unit is in standby mode, charging will not start when using the USB cable connection. Turn this unit on and make sure the charging has started before switching this unit to standby mode.

## Bluetooth®

### Pairing cannot be done.

- Check the Bluetooth® device condition.

### The device cannot be connected.

- The pairing of the device was unsuccessful or the registration has been replaced. Try pairing the device again. (→ 7)
- This unit might be connected to a different device. Disconnect the other device and try pairing the device again. (→ 7)

### The device is connected but audio cannot be heard through this unit.

- For some built-in Bluetooth® devices, you have to set the audio output to "SC-HC38" manually. Read the operating instructions for the device for details.

### The sound is interrupted.

- The device is out of the 10 m (33 ft) communication range. Bring the Bluetooth® device closer to this unit.
- Remove any obstacle between this unit and the device.
- Other devices that use the 2.4 GHz frequency band (wireless LAN, microwaves, cordless phones, etc.) are interfering. Bring the Bluetooth® device closer to this unit and distance it from the other devices.
- Select "MODE1" for stable communication. (→ 7)

## Remote control

### The remote control doesn't work properly.

- The remote control and this unit are using a different code. (→ right, "REMOTE □")
- Is the battery depleted or is the battery inserted incorrectly? (→ 4)

## Messages

### The following messages or service numbers may appear on the unit's display.

"--:--"

- You plugged the AC power supply cord in for the first time or there was a power failure recently. Set the time (→ 10).

"ADJUST CLOCK"

- Clock is not set. Adjust the clock accordingly.

"ADJUST TIMER"

- Play timer is not set. Adjust the play timer accordingly.

"AUTO OFF"

- The unit has been left unused for about 30 minutes and will shut down within a minute. Press any button to cancel it.

"CANNOT SET"

- Select an audio source other than "BLUETOOTH".

"CHECKING CONNECTION"

- The unit is checking the connected iPod/iPhone/iPad.
- If this display keeps appearing, make sure that the battery of the iPod/iPhone/iPad is not depleted and that the iPod/iPhone/iPad is turned on and connected correctly. (→ 6)

"DIMMER"

- Appears 10 seconds after the volume is turned to "0".

"ERROR"

- Incorrect operation is performed. Read the instructions and try again.

"F□□" ("□" stands for a number.)

- There is a problem with this unit. Note down the displayed number, disconnect the AC supply cord and consult your dealer.

---

### “ILLEGAL OPEN”

- Sliding door is not in correct position. Turn the unit off and on again. If this display appears again, consult the dealer.
- 

### “IPOD\_DOCK OVER CURRENT ERROR”

### “IPOD\_PORT OVER CURRENT ERROR”

- The iPod/iPhone/iPad is drawing too much power. Disconnect the iPod/iPhone/iPad and turn the unit off and on again.
- 

### “NODEVICE”

- The iPod/iPhone/iPad device is not inserted correctly. Read the instructions and try again. (→ 6)
  - The battery of the iPod/iPhone/iPad is depleted. Charge the iPod/iPhone/iPad and turn it on before connecting.
- 

### “NO DISC”

- Insert a disc to be played. (→ 6)
- 

### “NO PLAY”

- A CD that is not in CD-DA format is inserted. It cannot be played.
- 

### “NOT SUPPORTED”

- You have connected an iPod/iPhone/iPad that cannot be played. (→ 14)
  - If the iPod/iPhone/iPad is compatible, turn it on and connect it correctly.
- 

### “READING”

- The unit is checking the CD information. After this display has disappeared, start operating.
- 

### “REMOTE □” (“□” stands for a number.)

- The remote control and this unit are using different codes. Change the code on the remote control.
    - When “REMOTE 1” is displayed, press and hold [OK] and [Ⓜ] for more than 4 seconds.
    - When “REMOTE 2” is displayed, press and hold [OK] and [CD/RADIO] for more than 4 seconds.
- 

## Licenses

Made for



iPod



iPhone



iPad

“Made for iPod”, “Made for iPhone”, and “Made for iPad” mean that an electronic accessory has been designed to connect specifically to iPod, iPhone, or iPad, respectively, and has been certified by the developer to meet Apple performance standards.

Apple is not responsible for the operation of this device or its compliance with safety and regulatory standards.

Please note that the use of this accessory with iPod, iPhone, or iPad may affect wireless performance.

iPad, iPhone, iPod, iPod classic, iPod nano, and iPod touch are trademarks of Apple Inc., registered in the U.S. and other countries.

The Bluetooth® word mark and logos are owned by the Bluetooth SIG, Inc. and any use of such marks by Panasonic Corporation is under license. Other trademarks and trade names are those of their respective owners.

# Playable media

## Compatible iPod/iPhone/iPad

### Compatible with Lightning connector

iPod touch® (5th generation)
iPod nano® (7th generation)
iPhone® 5

### Compatible with iPod port connection

iPod touch® 1st, 2nd, 3rd, 4th, and 5th generation
iPod nano® 2nd, 3rd, 4th, 5th, 6th, and 7th generation
iPhone® 5 / iPhone® 4S / iPhone® 4 / iPhone® 3GS / iPhone® 3G / iPhone®
iPad® (1st, 3rd, and 4th generation) / iPad® 2 (2nd generation)
iPad® mini

(as of December 2012)



- Compatibility depends on the software version. Update your iPod/iPhone/iPad to the latest software before using it with this unit.
- Please be aware that Panasonic accepts no responsibility for the loss of data and/or information.

## Compatible CD

- A disc with the CD Logo.



- This unit can play back discs that conform to the CD-DA format.
- The unit may not be able to play some discs due to the condition of the recording.
- This unit cannot play back MP3 files.

### Note about using a DualDisc

- The digital audio content side of a DualDisc does not meet the technical specifications of the Compact Disc Digital Audio (CD-DA) format so play may not be possible.
- Do not use a DualDisc in this unit as it may not be possible to insert it correctly and it may get scratched or scraped.

# About Bluetooth®

Panasonic bears no responsibility for data and/or information that is compromised during a wireless transmission.

## Frequency band used

This unit uses the 2.4 GHz frequency band.

## Certification of this device

- This system conforms to frequency restrictions and has received certification based on frequency laws. Thus, a wireless permit is not necessary.
- The action below are punishable by law in some countries:
  - Taking apart or modifying the unit.
  - Removing specification indications.

## Restrictions of use

- Wireless transmission and/or usage with all Bluetooth® equipped devices is not guaranteed.
- All devices must conform to standards set by Bluetooth SIG, Inc.
- Depending on the specifications and settings of a device, it can fail to connect or some operations can be different.
- This system supports Bluetooth® security features. But depending on the operating environment and/or settings, this security is possibly not sufficient. Transmit data wirelessly to this system with caution.
- This system cannot transmit data to a Bluetooth® device.

## Range of use

Use this device at a maximum range of 10 m (33 ft).

The range can decrease depending on the environment, obstacles or interference.

## Interference from other devices

- This unit may not function properly and troubles such as noise and sound jumps may arise due to radio wave interference if this unit is located too close to other Bluetooth® devices or the devices that use the 2.4 GHz band.
- This unit may not function properly if radio waves from a nearby broadcasting station, etc. is too strong.

## Intended usage

- This unit is for normal, general use only.
- Do not use this system near an equipment or in an environment that is sensitive to radio frequency interference (example: airports, hospitals, laboratories, etc).

# Specifications

## ■ GENERAL

Power consumption	34 W
Power consumption in standby mode*1	Approx. 0.1 W
Power consumption in standby mode (With the iPod dock out)	Approx. 0.4 W
Power supply	AC 120 V, 60 Hz

## Dimensions (W×H×D)

500 mm×204 mm×84 mm  
(19 11/16"×8 1/32"×3 5/16")  
(Depth without stand: 75 mm (3"))

## Mass (Weight)

Approx. 2.6 kg (5.7 lbs)

## Operating temperature range

0 °C to +40 °C (+32 °F to +104 °F)

## Operating humidity range

35 % to 80 % RH (no condensation)

## ■ AMPLIFIER SECTION

### Output power:

#### RMS Output Power Stereo mode

##### Front Ch (both ch driven)

20 W per channel (6 Ω), 1 kHz, 10 % THD

##### Total RMS Stereo mode power

40 W

#### FTC Output Power Stereo mode

##### Front Ch (both ch driven)

15 W per channel (6 Ω),  
20 Hz to 20 kHz, 1 % THD

##### Total FTC Stereo mode power

30 W

## ■ TUNER SECTION

### Preset Memory

FM 30 stations

### Frequency Modulation (FM)

#### Frequency range

87.9 MHz to 107.9 MHz (200 kHz step)

87.5 MHz to 108.0 MHz (100 kHz step)

#### Antenna terminals

75 Ω (unbalanced)

## ■ DISC SECTION

### Disc played [8 cm (3") or 12 cm (5")]

CD, CD-R/RW (CD-DA)

### Pick up

#### Wavelength

790 nm (CD)

### Audio output (Disc)

#### Number of channels

2 ch (FL, FR)

## ■ SPEAKER SYSTEM SECTION

### Type

1 way, 1 speaker system (Passive Radiator)

### Speaker unit(s)

#### Full range

6.5 cm (2 1/2") Cone type×1 per channel

#### Passive Radiator

8 cm (3 1/8")×2 per channel

### Impedance

6 Ω

## ■ TERMINAL SECTION

### Lightning Connector

DC OUT 5 V, 1.0 A MAX

### iPod Port

DC OUT 5 V, 2.1 A MAX

## ■ BLUETOOTH SECTION

### Bluetooth system specification

V 3.0

### Wireless equipment classification

Class 2

### Supported profiles

A2DP, AVRCP, GAVDP

### Frequency band

2402 MHz to 2480 MHz  
(Adaptive Frequency Hopping)

### Driving distance

10 m (33 ft) Line of sight



- Specifications are subject to change without notice. Mass and dimensions are approximate.
- Total harmonic distortion is measured by a digital spectrum analyzer.

\*1: When the iPod/iPhone/iPad is not charging and the dock is closed.

# Attaching the unit to a wall (optional)

## Installation accessories

### Supplied accessories

- 1 Safety holder
- 1 Screw
- 2 Wall mount brackets

### Commercially available accessories (not supplied)

- 4 Wall mount bracket fixing screws
- 1 Safety holder fixing screw
- 1 Fall prevention cord
- 1 Screw eye

- Keep the safety holder out of reach of children to prevent swallowing.
- Keep the screws out of reach of children to prevent swallowing.
- Keep the wall mount brackets out of reach of children to prevent swallowing.



Use screws with a nominal diameter of 4 mm ( $\frac{5}{32}$ " ), which are suitable to the material of the wall (e.g., wood, steel, concrete, etc.)

## Safety precautions

**Professional installation is required.**

**The installation should never be done by any other than a qualified installation specialist. PANASONIC DISCLAIMS ANY PROPERTY DAMAGE AND/OR SERIOUS INJURY, INCLUDING DEATH RESULTING FROM IMPROPER INSTALLATION OR INCORRECT HANDLING.**

- Be sure to install this unit as indicated within this Owner's Manual.

## Wall mount instructions

**Before installation, turn the unit off and disconnect the AC power supply cord from the AC outlet.**

- 1 Detach the stand from the unit.
  - ↳ Unscrew the fixing screw (2 pieces) at the bottom of the unit.
  - ↳ Gently pull the stand off the unit as illustrated.
  - Keep the removed screws and stand in a safe place.

Bottom of the unit

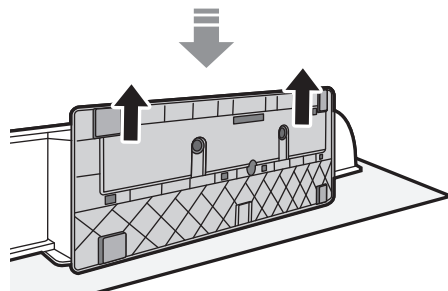
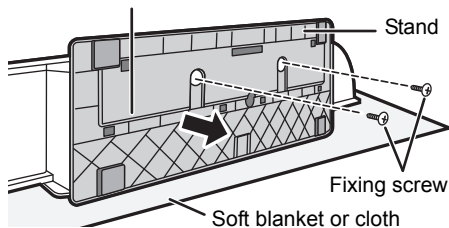

- 2 Measure and mark the position of the wall mount brackets (Both sides).

↳ Use figures below to identify the screwing positions.

### The position to attach the wall mount brackets

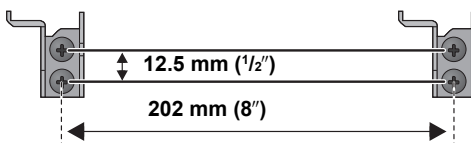

### Space required

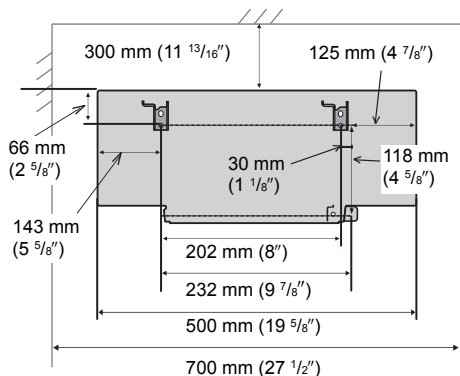



- 3** Attach the wall mount bracket to the wall with 2 screws (not supplied). (Both sides)
- Use a spirit level to ensure both wall mount brackets are level.
  - Make sure that the screw used and the wall are strong enough to support the weight of at least 33 kg (72.8 lbs).

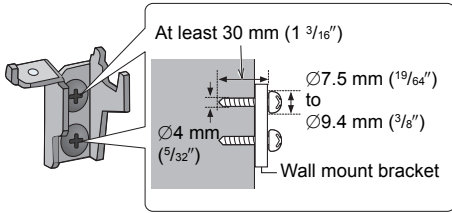

- 4** Fix the safety holder onto the unit with the screw (supplied).
- ↳ Screw tightening torque: 50 N•cm (0.4 lbf•ft) to 70 N•cm (0.5 lbf•ft).

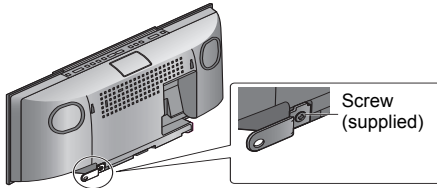

- 5** Attach the fall prevention cord (not supplied) to this unit.
- Use a cord that is capable of supporting over 33 kg (72.8 lbs) (with a diameter of about 1.5 mm (1/16")).

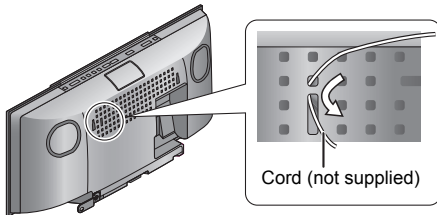

- 6** Hook the unit securely onto the wall mount brackets with both hands.
- Connect the FM antenna and the AC power supply cord to the unit before hanging the unit onto the wall. (→ 5)
  - After hanging the unit, release your hand carefully to confirm the unit sits securely on the wall.

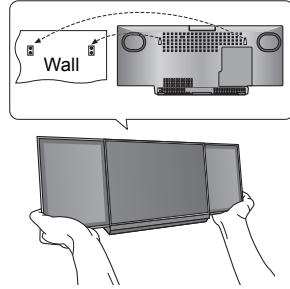

- 7** Drive the safety holder fixing screw (not supplied) to secure the safety holder onto the wall.
- Make sure that the screw used and the wall are strong enough to support the weight of at least 33 kg (72.8 lbs).
  - Refer to step 3 for requirements before screwing.

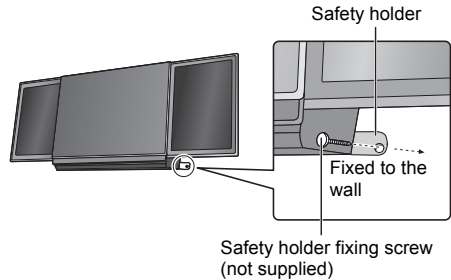

- 8** Attach the fall prevention cord (not supplied) to the wall.
- Make sure that the screw used and the wall are strong enough to support the weight of at least 33 kg (72.8 lbs).
  - Make sure that the slack of the cord is minimal.

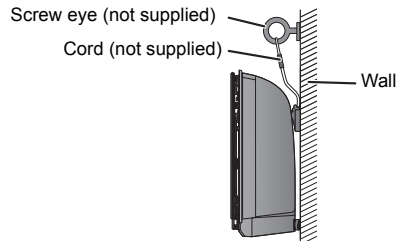

# Spanish Quick Reference / Referencia rápida en español

## Conexiones

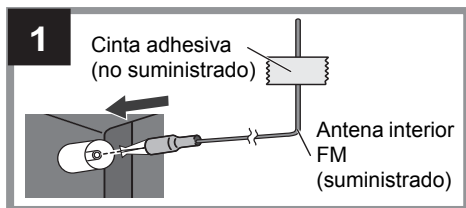

**2** Conecte el cable de alimentación AC después de que todas las demás conexiones estén completas.

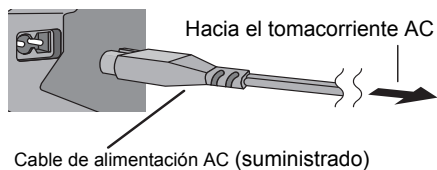

- Consumo de energía en Standby (modo de espera): Aprox. 0,1 W

## Insertar o sacar los medios

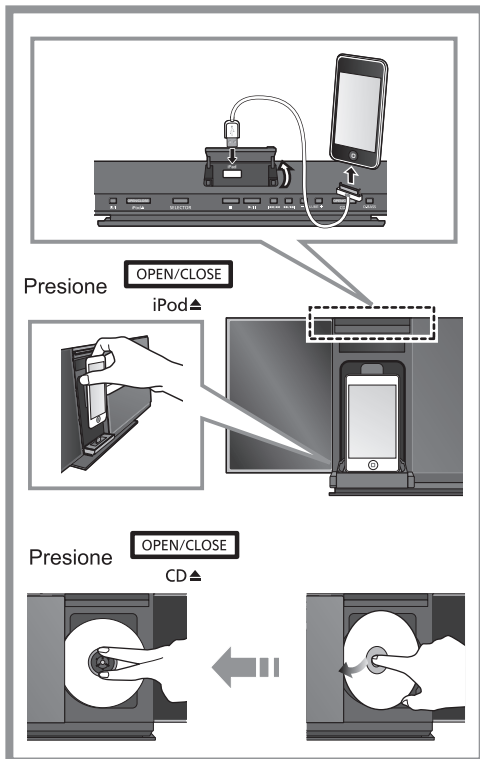

## Operaciones de reproducción de medios

### Preparación

- Encienda la unidad.
- Inserte el medio. (→ arriba)
- Presione [CD] o [iPod] para seleccionar la fuente de audio.

### Reproducción básica

<b>Reproducir</b>	Presione [▶/  ].
<b>Detención</b>	Presione [■].
<b>Pausa</b>	Presione [▶/  ]. Presione nuevamente para reiniciar la reproducción.
<b>Saltear</b>	Presione [◀◀/▶▶] o [▶▶/▶▶] para saltar una pista.
<b>Búsqueda</b>	Durante la reproducir o pausa Mantenga presionado [◀◀/▶▶] o [▶▶/▶▶].

## Reloj y temporizador

### Ajuste del reloj

Éste es un reloj de 12 horas.

- 1 Presione [SETUP] para seleccionar "CLOCK".
- 2 Presione [▲, ▼] para seleccionar la hora y luego presione [OK].

# Limited Warranty (ONLY FOR U.S.A. AND PUERTO RICO)

Panasonic Consumer Marketing Company of North America,  
Division of Panasonic Corporation of North America  
One Panasonic Way, Secaucus, New Jersey 07094

## Panasonic Products Limited Warranty

### Limited Warranty Coverage (For USA and Puerto Rico Only)

If your product does not work properly because of a defect in materials or workmanship, Panasonic Consumer Marketing Company of North America (referred to as "the warrantor") will, for the length of the period indicated on the chart below, which starts with the date of original purchase ("warranty period"), at its option either (a) repair your product with new or refurbished parts, (b) replace it with a new or a refurbished equivalent value product, or (c) refund your purchase price. The decision to repair, replace or refund will be made by the warrantor.

Product or Part Name	Parts	Labor
Compact Stereo System	1 Year	1 Year
All included Accessories (Except Non-Rechargeable Batteries)	90 Days	Not Applicable
Only Non-Rechargeable Batteries	10 Days	Not Applicable

During the "Labor" warranty period there will be no charge for labor. During the "Parts" warranty period, there will be no charge for parts. This Limited Warranty excludes both parts and labor for non-rechargeable batteries, antennas, and cosmetic parts (cabinet). This warranty only applies to products purchased and serviced in the United States or Puerto Rico. This warranty is extended only to the original purchaser of a new product which was not sold "as is".

### Mail-In Service

For assistance in the U.S.A. and Puerto Rico in obtaining repairs, please ship the product prepaid to:

**Panasonic Exchange Center**  
4900 George McVay Drive  
Suite B  
McAllen, TX 78503  
[panacare@us.panasonic.com](mailto:panacare@us.panasonic.com)

### Online Repair Request

To submit a new repair request and for quick repair status visit our Web Site at [www.panasonic.com/repair](http://www.panasonic.com/repair).

When shipping the unit, carefully pack, include all supplied accessories listed in the Owner's Manual, and send it prepaid, adequately insured and packed well in a carton box. When shipping Lithium Ion batteries please visit our Web Site at [www.panasonic.com/BatteryHandling](http://www.panasonic.com/BatteryHandling) as Panasonic is committed to providing the most up to date information. Include a letter detailing the complaint, a return address and provide a daytime phone number where you can be reached. A valid registered receipt is required under the Limited Warranty.

**IF REPAIR IS NEEDED DURING THE WARRANTY PERIOD, THE PURCHASER WILL BE REQUIRED TO FURNISH A SALES RECEIPT/ PROOF OF PURCHASE INDICATING DATE OF PURCHASE, AMOUNT PAID AND PLACE OF PURCHASE. CUSTOMER WILL BE CHARGED FOR THE REPAIR OF ANY UNIT RECEIVED WITHOUT SUCH PROOF OF PURCHASE.**

### Limited Warranty Limits And Exclusions

This warranty ONLY COVERS failures due to defects in materials or workmanship, and DOES NOT COVER normal wear and tear or cosmetic damage. The warranty ALSO DOES NOT COVER damages which occurred in shipment, or failures which are caused by products not supplied by the warrantor, or failures which result from accidents, misuse, abuse, neglect, mishandling, misapplication, alteration, faulty installation,

set-up adjustments, misadjustment of consumer controls, improper maintenance, power line surge, lightning damage, modification, introduction of sand, humidity or liquids, commercial use such as hotel, office, restaurant, or other business or rental use of the product, or service by anyone other than a Factory Service Center or other Authorized Servicer, or damage that is attributable to acts of God.

**THERE ARE NO EXPRESS WARRANTIES EXCEPT AS LISTED UNDER "LIMITED WARRANTY COVERAGE". THE WARRANTOR IS NOT LIABLE FOR INCIDENTAL OR CONSEQUENTIAL DAMAGES RESULTING FROM THE USE OF THIS PRODUCT, OR ARISING OUT OF ANY BREACH OF THIS WARRANTY.** (As examples, this excludes damages for lost time, travel to and from the servicer, loss of or damage to media or images, data or other memory or recorded content. The items listed are not exclusive, but for illustration only.) **ALL EXPRESS AND IMPLIED WARRANTIES, INCLUDING THE WARRANTY OF MERCHANTABILITY, ARE LIMITED TO THE PERIOD OF THE LIMITED WARRANTY.**

Some states do not allow the exclusion or limitation of incidental or consequential damages, or limitations on how long an implied warranty lasts, so the exclusions may not apply to you.

This warranty gives you specific legal rights and you may also have other rights which vary from state to state. If a problem with this product develops during or after the warranty period, you may contact your dealer or Service Center. If the problem is not handled to your satisfaction, then write to the warrantor's Consumer Affairs Department at the addresses listed for the warrantor.

**PARTS AND SERVICE, WHICH ARE NOT COVERED BY THIS LIMITED WARRANTY, ARE YOUR RESPONSIBILITY.**

### Customer Services Directory (United States and Puerto Rico)

Obtain Product Information and Operating Assistance; locate your nearest Dealer or Service Center; purchase Parts and Accessories; or make Customer Service and Literature requests by visiting our Web Site at:

<http://www.panasonic.com/help>

or, contact us via the web at:

<http://www.panasonic.com/contactinfo>

You may also contact us directly at:

1-800-211-PANA (7262)

Monday-Friday 9am-9pm,

Saturday-Sunday 10am-7pm EST

**For hearing or speech impaired TTY users, TTY: 1-877-833-8855**

### Accessory Purchases (United States and Puerto Rico)

Purchase Parts, Accessories and Instruction Books online for all Panasonic Products by visiting our Web Site at:

<http://www.pstc.panasonic.com>

Or, send your request by E-mail to:

[npcparts@us.panasonic.com](mailto:npcparts@us.panasonic.com)

You may also contact us directly at:

1-800-332-5368 (Phone) 1-800-237-9080 (Fax Only)

(Monday-Friday 9am-9pm EST)

Panasonic National Parts Center

20421 84th Ave S., Kent, WA 98032

(We accept Visa, MasterCard, Discover Card, American Express)

**For hearing or speech impaired TTY users, TTY: 1-866-605-1277**

As of October 2012

### User memo:

DATE OF PURCHASE	_____
DEALER NAME	_____
DEALER ADDRESS	_____
TELEPHONE NUMBER	_____

The model number and serial number of this product can be found on either the back or the bottom of the unit. Please note them in the space provided below and keep for future reference.

MODEL NUMBER SC-HC38

SERIAL NUMBER \_\_\_\_\_

ENGLISH

ESPAÑOL

**FCC Note:**

This equipment has been tested and found to comply with the limits for a Class B digital device, pursuant to Part 15 of the FCC Rules.

These limits are designed to provide reasonable protection against harmful interference in a residential installation. This equipment generates, uses and can radiate radio frequency energy and, if not installed and used in accordance with the instructions, may cause harmful interference to radio communications.

However, there is no guarantee that interference will not occur in a particular installation. If this equipment does cause harmful interference to radio or television reception, which can be determined by turning the equipment off and on, the user is encouraged to try to correct the interference by one or more of the following measures:

- Reorient or relocate the receiving antenna.
- Increase the separation between the equipment and receiver.
- Connect the equipment into an outlet on a circuit different from that to which the receiver is connected.
- Consult the dealer or an experienced radio/TV technician for help.

Any unauthorized changes or modifications to this equipment would void the user's authority to operate this device.

This device complies with Part 15 of the FCC Rules.

Operation is subject to the following two conditions:

- (1) This device may not cause harmful interference, and
- (2) this device must accept any interference received, including interference that may cause undesired operation.

Responsible Party:

Panasonic Corporation of North America  
One Panasonic Way  
Secaucus, NJ 07094

Support Contact:

Panasonic Consumer Marketing Company of North America  
Telephone No.: 1-800-211-PANA (7262)

This transmitter must not be co-located or operated in conjunction with any other antenna or transmitter.

This equipment complies with FCC/IC radiation exposure limits set forth for an uncontrolled environment and meets the FCC radio frequency (RF) Exposure Guidelines in Supplement C to OET65 and RSS-102 of the IC radio frequency (RF) Exposure rules. This equipment has very low levels of RF energy that is deemed to comply without maximum permissive exposure evaluation (MPE). But it is desirable that it should be installed and operated keeping the radiator at least 20 cm (7 7/8") or more away from person's body (excluding extremities: hands, wrists, feet and ankles).



As an ENERGY STAR® Partner, Panasonic has determined that this product meets the ENERGY STAR® guidelines for energy efficiency.



Panasonic Consumer Marketing  
Company of North America,  
Division of Panasonic Corporation of  
North America

One Panasonic Way, Secaucus,  
New Jersey 07094

<http://www.panasonic.com>

