

Panasonic[®]

Operating Instructions
Wireless System

Model No. **SH-FX71**

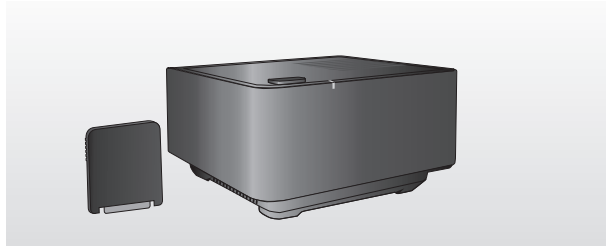

Designed for Panasonic Home Theater Sound Systems that are compatible with the SH-FX71.

If you have any questions contact
In the U.S.A. and Puerto Rico:
1-800-211-PANA (7262)
In Canada: 1-800-561-5505

Only for U.S.A. and Puerto Rico:
The warranty can be found on page 13.
Only for Canada: The warranty can be found on page 15.

Panasonic Consumer Electronics
Company, Division of Panasonic
Corporation of North America
One Panasonic Way, Secaucus,
New Jersey 07094
<http://www.panasonic.com>

Panasonic Canada Inc.
5770 Ambler Drive
Mississauga, Ontario
L4W 2T3
www.panasonic.ca

PP En

© Panasonic Corporation 2009
Printed in Malaysia

RQTX1122-Y
F1209SA0

Confidential until
2009/12/30

WARNING:

TO REDUCE THE RISK OF FIRE, ELECTRIC SHOCK OR PRODUCT DAMAGE,

- **DO NOT EXPOSE THIS APPARATUS TO RAIN, MOISTURE, DRIPPING OR SPLASHING AND THAT NO OBJECTS FILLED WITH LIQUIDS, SUCH AS VASES, SHALL BE PLACED ON THE APPARATUS.**
- **USE ONLY THE RECOMMENDED ACCESSORIES.**
- **DO NOT REMOVE THE COVER (OR BACK); THERE ARE NO USER SERVICEABLE PARTS INSIDE. REFER SERVICING TO QUALIFIED SERVICE PERSONNEL.**

CAUTION!

DO NOT INSTALL OR PLACE THIS UNIT IN A BOOKCASE, BUILT-IN CABINET OR IN ANOTHER CONFINED SPACE. ENSURE THE UNIT IS WELL VENTILATED. TO PREVENT RISK OF ELECTRIC SHOCK OR FIRE HAZARD DUE TO OVERHEATING, ENSURE THAT CURTAINS AND ANY OTHER MATERIALS DO NOT OBSTRUCT THE VENTILATION VENTS.

The socket outlet shall be installed near the equipment and easily accessible.
The mains plug of the power supply cord shall remain readily operable.
To completely disconnect this apparatus from the AC Mains, disconnect the power supply cord plug from AC receptacle.

THE FOLLOWING APPLIES ONLY IN THE U.S.A. FCC Note:

This equipment has been tested and found to comply with the limits for a Class B digital device, pursuant to Part 15 of the FCC Rules. These limits are designed to provide reasonable protection against harmful interference in a residential installation. This equipment generates, uses and can radiate radio frequency energy and, if not installed and used in accordance with the instructions, may cause harmful interference to radio communications. However, there is no guarantee that interference will not occur in a particular installation. If this equipment does cause harmful interference to radio or television reception, which can be determined by turning the equipment off and on, the user is encouraged to try to correct the interference by one or more of the following measures:

- Reorient or relocate the receiving antenna.
- Increase the separation between the equipment and receiver.
- Connect the equipment into an outlet on a circuit different from that to which the receiver is connected.
- Consult the dealer or an experienced radio/TV technician for help.

FCC caution: To maintain compliance with FCC regulations, shielded interface cables must be used with this equipment. Operation with non-approved equipment or unshielded cables may result in interference to radio and TV reception. Any changes or modifications not approved by the party responsible for compliance could void the user's authority to operate this equipment.

This device complies with Part 15 of the FCC Rules.

Operation is subject to the following two conditions:

- (1) This device may not cause harmful interference, and
- (2) this device must accept any interference received, including interference that may cause undesired operation.

Responsible Party:

Panasonic Corporation of North America
One Panasonic Way
Secaucus, NJ 07094

Support Contact:

Panasonic Consumer Electronics Company
Telephone No.: 1-800-211-PANA (7262)



WARNING:

To satisfy FCC RF exposure requirements for mobile transmitting devices, a separation distance of 20 cm or more should be maintained between the antenna of this device and persons during device operation.

To ensure compliance, operations at closer than this distance is not recommended. The antenna used for this transmitter must not be co-located in conjunction with any other antenna or transmitter.

IMPORTANT SAFETY INSTRUCTIONS

Read these operating instructions carefully before using the unit. Follow the safety instructions on the unit and the applicable safety instructions listed below. Keep these operating instructions handy for future reference.

- 1) Read these instructions.
- 2) Keep these instructions.
- 3) Heed all warnings.
- 4) Follow all instructions.
- 5) Do not use this apparatus near water.
- 6) Clean only with dry cloth.
- 7) Do not block any ventilation openings. Install in accordance with the manufacturer's instructions.
- 8) Do not install near any heat sources such as radiators, heat registers, stoves, or other apparatus (including amplifiers) that produce heat.
- 9) Do not defeat the safety purpose of the polarized or grounding-type plug. A polarized plug has two blades with one wider than the other. A grounding-type plug has two blades and a third grounding prong. The wide blade or the third prong are provided for your safety. If the provided plug does not fit into your outlet, consult an electrician for replacement of the obsolete outlet.
- 10) Protect the power cord from being walked on or pinched particularly at plugs, convenience receptacles, and the point where they exit from the apparatus.
- 11) Only use attachments/accessories specified by the manufacturer.
- 12) Use only with the cart, stand, tripod, bracket, or table specified by the manufacturer, or sold with the apparatus. When a cart is used, use caution when moving the cart/apparatus combination to avoid injury from tip-over.
- 13) Unplug this apparatus during lightning storms or when unused for long periods of time.
- 14) Refer all servicing to qualified service personnel. Servicing is required when the apparatus has been damaged in any way, such as power-supply cord or plug is damaged, liquid has been spilled or objects have fallen into the apparatus, the apparatus has been exposed to rain or moisture, does not operate normally, or has been dropped.



IMPORTANT SAFETY INSTRUCTIONS

Product Identification Marking is located on the bottom of unit.

THE FOLLOWING APPLIES ONLY IN CANADA.
This Class B digital apparatus complies with Canadian ICES-003.

THE FOLLOWING APPLIES ONLY IN CANADA.
This device complies with RSS-210 of the IC Rules. Operation is subject to the following two conditions:
(1) This device may not cause harmful interference,
(2) This device must accept any interference received, including interference that may cause undesired operation of the device.

The following mark and symbols are located on bottom of the unit.

	CAUTION RISK OF ELECTRIC SHOCK DO NOT OPEN	
CAUTION: TO REDUCE THE RISK OF ELECTRIC SHOCK, DO NOT REMOVE SCREWS. NO USER-SERVICEABLE PARTS INSIDE. REFER SERVICING TO QUALIFIED SERVICE PERSONNEL.		



The lightning flash with arrowhead symbol, within an equilateral triangle, is intended to alert the user to the presence of uninsulated "dangerous voltage" within the product's enclosure that may be of sufficient magnitude to constitute a risk of electric shock to persons.



The exclamation point within an equilateral triangle is intended to alert the user to the presence of important operating and maintenance (servicing) instructions in the literature accompanying the appliance.

RQTX1122

Accessories

Dear customer

Thank you for purchasing this product. For optimum performance and safety, please read these instructions carefully.

**Before connecting, operating or adjusting this product, please read the instructions completely.
Please keep this manual for future reference.**

User memo:

DATE OF PURCHASE _____
DEALER NAME _____
DEALER ADDRESS _____
TELEPHONE NUMBER _____

The model number and serial number of this product can be found on either the back or the bottom of the unit. Please note them in the space provided below and keep for future reference.

MODEL NUMBER _____ SH-FX71 _____
SERIAL NUMBER _____

- If you see this symbol-

Information on Disposal in other Countries outside the European Union



This symbol is only valid in the European Union. If you wish to discard this product, please contact your local authorities or dealer and ask for the correct method of disposal.

Accessories

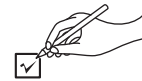

Please check and identify the supplied accessories. Use numbers indicated in parentheses when asking for replacement parts. (Product numbers correct as of December 2009. This may be subject to change.)

For U.S.A. and Puerto Rico:
To order accessories, refer to "Accessory Purchases (United States and Puerto Rico)" on page 14.
For Canada:
To order accessories, call the dealer from whom you made your purchase.

- Digital transmitter (RFAX1012)



- AC power supply cord (K2CB2CB00021)
For use with this unit only. Do not use it with other equipment. Also, do not use cords for other equipment with this unit.



- 2 Speaker cables
[REEX0992 (Blue), REEX0993 (Gray)]



RQTX1122

Control reference guide

Table of contents

■ Top of the main unit

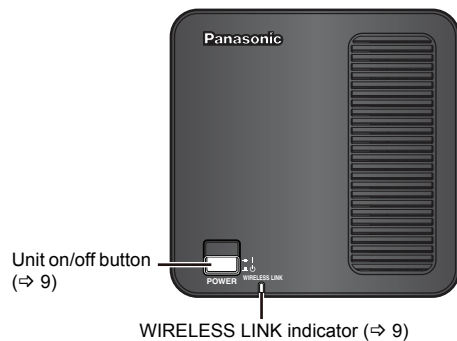

■ Rear of the main unit

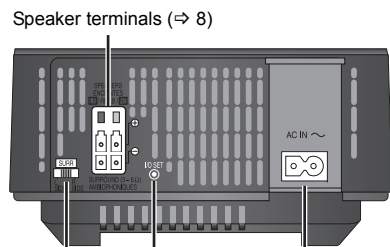

Note

- Place the main unit in a horizontal position with the top panel facing upward.
- To allow for proper ventilation and to maintain good airflow around the main unit, position it with at least 5 cm (2") of space on all sides.

Introduction

IMPORTANT SAFETY INSTRUCTIONS.....	3
Accessories	4
Control reference guide	5

Use

Setup	6
Connections	7
Making the wireless link	9
Using the surround back speakers	10

Reference

Product service.....	11
Troubleshooting guide	11
Specifications	12
Maintenance	12
Limited Warranty (ONLY FOR U.S.A. AND PUERTO RICO).....	13
Limited Warranty (ONLY FOR CANADA).....	15

Control reference guide / Table of contents

Setup

Setup

Preparation

- Turn off all equipment before connection and read the appropriate operating instructions.
- **Connect the AC power supply cord after all other connections are complete.**

Note

- Do not use the wireless system and digital transmitter inside a metal cabinet or bookshelf.
- Do not attempt to connect any extra surround speakers to the home theater unit.
- Place the wireless system within approximately 10 m (33 ft) from the home theater unit.

To avoid interference, maintain the following distances between the wireless system and other electronic devices that use the same radio frequency (2.4 GHz band).

e.g.

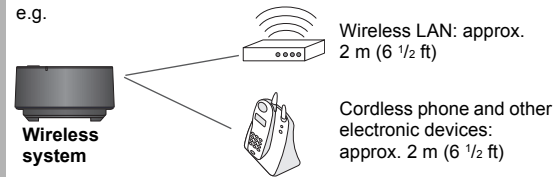

The wireless system will automatically seek a clear channel if any of these other devices interfere with its communication. When this happens, the wireless link indicator ("W") or an indicator flashes on the home theater unit, and there will be a brief audio interruption coming from the surround speakers.

This is the normal operation of the product working to assure the best possible performance of your home theater unit.

If the interference persists, try moving the other devices to another location outside the range of the wireless system, or move the wireless system nearer to your home theater unit.

■ Wireless setup diagram

e.g. **5.1ch**

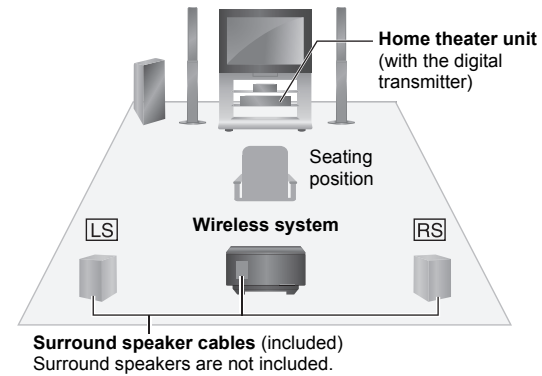

LS: Surround (left), RS: Surround (right)

- Place on the side of or slightly behind the seating position.

e.g. **7.1ch** (Using two units of the wireless system)

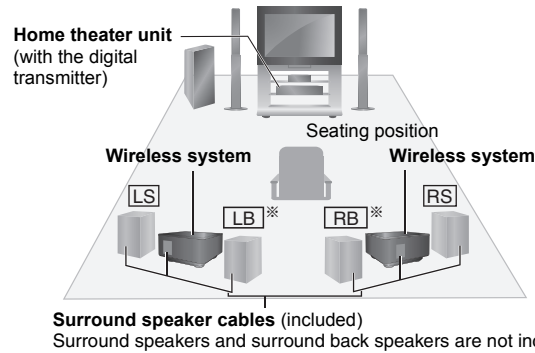

This placement offers 7.1-channel playback. Your home theater unit must be capable of 7.1-channel playback.

LS: Surround (left), **RS:** Surround (right)
● Place on the side of the seating position.

LB*: Surround back (left), **RB*:** Surround back (right)
● Place behind the seating position, about 1 m (3 ft) higher than ear level.
*LB or SBL RB or SBR

Connections

■ Digital transmitter

Refer also to the operating instructions for your home theater unit.

Do not insert or remove while the home theater unit is on.

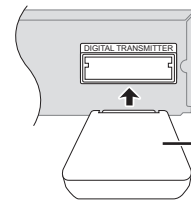

e.g.
Rear of the home theater unit

Digital transmitter (included)
Insert fully until you hear a click.

Setup

(Continued on next page)

Setup

Connections

Setup

■ Wireless system

Preparation

If the surround speaker cables (with a blue connector and a gray connector) have already been connected, disconnect the surround speaker cables from your home theater unit.

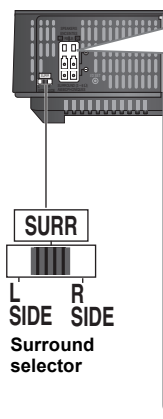

Connecting the speakers to the wireless system
Connect to terminals of the same color.

Speaker cable
Insert fully.

Impedance: 3 Ω to 6 Ω
Speaker input power: 100 W (Min)

For 5.1ch connection
SURROUND (LS): Blue
SURROUND (RS): Gray

Selector setting for the left and right speakers



For 7.1ch connection
SURROUND (LS): Blue
SURROUND BACK (LB): Gray

Selector setting for the left speakers



SURROUND (RS): Gray
SURROUND BACK (RB): Blue

Selector setting for the right speakers



■ AC power supply cord

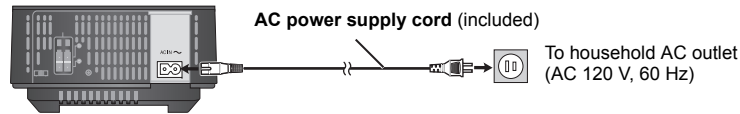

Making the wireless link

- Refer also to the operating instructions for your home theater unit.
- When you enjoy 7.1-channel playback, refer also to "Using the surround back speakers" (⇒ 10).

1 Turn on the wireless system.

Unit on/off button [POWER I,]

Use this button to turn the unit on and off.

 I: The unit is on.  : The unit is off.

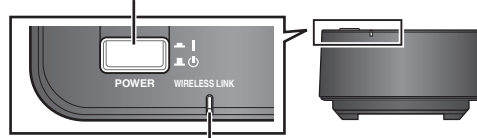

WIRELESS LINK indicator

Red: The unit is on and the wireless link is deactivated.
Green: The unit is on and the wireless link is activated.

2 Turn on your home theater unit.

The wireless link indicator on your home theater unit will be turned on.

- The type of the indicator varies according to the home theater unit.
e.g. Display on the home theater unit



- If the indicator is flashing, refer to Troubleshooting guide (⇒ 11).

3 Start play on the home theater unit.

Conserving power

The wireless system consumes a small amount of power, even when it is off (approx. 0.2 W). To save power when the unit is not to be used for a long time, unplug it from the household AC outlet.

Setup

RQTX1122

Setup

Using the surround back speakers

Setup

By using 2 sets of SH-FX71, you can enjoy 7.1-channel playback, making the surround speakers and surround back speakers wireless (⇒ 7).

Use only a digital transmitter supplied with the SH-FX71. Wireless system is originally paired to work with the digital transmitter that comes along with it. For the digital transmitter to work with the additional wireless system, pairing is necessary.

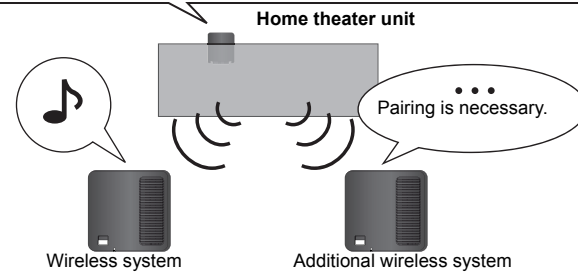

e.g. After pairing

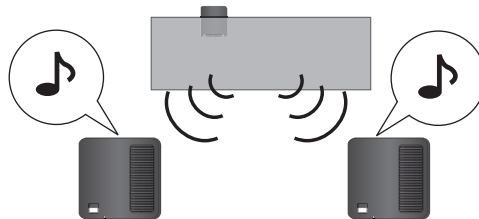

10

- Keep the digital transmitter of the additional wireless system for later use.

■ Pairing

Preparation

- Make sure to connect the AC power supply cord of the additional wireless system.
- Turn on the home theater unit and reduce the volume.

- 1 Turn on the additional wireless system.
- 2 While pressing the stop button (e.g. [■]) on the home theater unit, press the numbered button [2] on the remote control until "P" lights in the home theater unit's display.
- 3 While "P" is displayed, press [I/D SET] on the rear of the additional wireless system.
 - The indicator on the additional system turns green.
 - If "P" goes off before you press [I/D SET], repeat step 2 and then continue the procedure.
- 4 While pressing the stop button on the home theater unit, press the numbered button [2] on the remote control.
- 5 Turn off and on the additional wireless system.
 - Make sure the indicator on the additional wireless system lights up green.

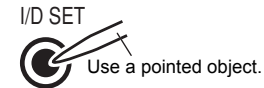

Note

- If you should change the digital transmitter card, repeat the pairing steps using the new digital transmitter.
- SH-FX71 cannot be used with SH-FX65, SH-FX67 or SH-FX70.

Product service

- 1 **Damage requiring service**—The unit should be serviced by qualified service personnel if:
 - (a) The AC power supply cord or AC adaptor has been damaged; or
 - (b) Objects or liquids have gotten into the unit; or
 - (c) The unit has been exposed to rain; or
 - (d) The unit does not operate normally or exhibits a marked change in performance; or
 - (e) The unit has been dropped or the cabinet damaged.
- 2 **Servicing**—Do not attempt to service the unit beyond that described in these operating instructions. Refer all other servicing to authorized servicing personnel.
- 3 **Replacement parts**—When parts need replacing ensure the servicer uses parts specified by the manufacturer or parts that have the same characteristics as the original parts. Unauthorized substitutes may result in fire, electric shock, or other hazards.
- 4 **Safety check**—After repairs or service, ask the servicer to perform safety checks to confirm that the unit is in proper working condition.

The servicer will require all components to service your system. Therefore, should service ever be necessary, be sure to bring the entire system.

Product information

For product information or assistance with product operation:

In the U.S.A. and Puerto Rico, refer to “Customer Services Directory (United States and Puerto Rico)” on page 14.

In Canada, contact the Panasonic Canada Inc. Customer Care Centre at 1-800-561-5505, or visit the website (www.panasonic.ca), or an authorized Servicentre closest to you.

Troubleshooting guide

Before requesting service, make the following checks. If you are in doubt about some of the check points, or if the solutions indicated in the table do not solve the problem, refer to “Customer Services Directory (United States and Puerto Rico)” on page 14 if you reside in the U.S.A. or Puerto Rico, or refer to “Product information” on the left if you reside in Canada.

Main unit

No power.	<ul style="list-style-type: none"> • Ensure the AC power supply cord is connected properly.
The indicator does not turn green even though [I/D SET] is pressed and completed the pairing.	<ul style="list-style-type: none"> • Turn the wireless system off and then back on.
No sound from the left or right surround speaker.	<ul style="list-style-type: none"> • Refer to page 8 for the surround selector setting details and ensure that the selector is set at the correct position. Then, turn the wireless system off and then back on. • Verify the surround sound setting on the home theater unit.

On your home theater unit

The wireless link indicator (e.g. “W” or an indicator) is flashing.	<ul style="list-style-type: none"> • There is no link between the home theater unit and the wireless system. Turn the wireless system off and then back on. Alternatively, turn the wireless system off, disconnect the AC power supply cord, and then reconnect it.
The wireless link indicator (e.g. “W” or an indicator) does not light.	<ul style="list-style-type: none"> • Check that the home theater unit is turned on, and the wireless system is turned on. • Ensure that the digital transmitter is fully inserted into the slot of the home theater unit.

Specifications

Maintenance

AMPLIFIER SECTION

Output power

RMS output power

Surround Ch	125 W per channel (3 Ω), 1 kHz, 10 % THD
Total RMS power	250 W

FTC output power

Surround Ch	34 W per channel (3 Ω), 120 Hz to 20 kHz, 1 % THD
Total FTC power	68 W

GENERAL

Power supply

AC 120 V, 60 Hz

Power consumption

Digital transmitter	1.2 W
Wireless system	35 W

Dimensions (W×H×D)

Digital transmitter	43.3 mm×37.3 mm×8.2 mm (1 11/16"×1 15/32"×5/16")
Wireless system	165 mm×91.5 mm×164 mm (6 1/2"×3 5/8"×6 15/32")

Mass [Weight]

Digital transmitter	0.0095 kg (0.0209 lbs)
Wireless system	0.662 kg (1.4595 lbs)

Wireless module

Frequency range	2.4 GHz to 2.4835 GHz
Number of channels	3

Operating temperature range 0 °C to +40 °C (+32 °F to +104 °F)

Operating humidity range 20 % to 80 % RH (no condensation)

Power consumption in off mode	approx. 0.2 W
--------------------------------------	---------------

Note

- Specifications are subject to change without notice. Mass and dimensions are approximate.
- Total harmonic distortion is measured by a digital spectrum analyzer.

Limited Warranty (ONLY FOR U.S.A. AND PUERTO RICO)

Panasonic Consumer Electronics Company,
 Division of Panasonic Corporation of North America
 One Panasonic Way, Secaucus, New Jersey 07094

Panasonic Audio Products Limited Warranty

Limited Warranty Coverage (For USA and Puerto Rico Only)

If your product does not work properly because of a defect in materials or workmanship, Panasonic Consumer Electronics Company (referred to as "the warrantor") will, for the length of the period indicated on the chart below, which starts with the date of original purchase ("warranty period"), at its option either (a) repair your product with new or refurbished parts, or (b) replace it with a new or a refurbished product. The decision to repair or replace will be made by the warrantor.

Product or Part Name	Parts	Labor
Audio Products (except items listed below)	One (1) year	One (1) year
USB Reader-Writer, Personal Computer Card Adapters (in exchange for defective item)	One (1) year	Not Applicable
Accessories: Headphones, Cartridges, Microphones, Adapters	Ninety (90) days	Ninety (90) days
Rechargeable Batteries, DVD-R/-RAM Discs (in exchange for defective item)	Ten (10) days	Not Applicable
SD Memory Cards, Rechargeable Battery Packs (in exchange for defective item)	Ninety (90) days	Not Applicable

During the "Labor" warranty period there will be no charge for labor. During the "Parts" warranty period, there will be no charge for parts. You must carry-in or mail-in your product during the warranty period. If non-rechargeable batteries are included, they are not warranted. This warranty only applies to products purchased and serviced in the United States or Puerto Rico. This warranty is extended only to the original purchaser of a new product which was not sold "as is". A purchase receipt or other proof of the original purchase date is required for warranty service.

Carry-In or Mail-In Service

For Carry-In or Mail-In Service in the United States and Puerto Rico call 1-800-211-PANA (7262) or visit Panasonic Web Site: <http://www.panasonic.com>

Limited Warranty Limits And Exclusions

This warranty ONLY COVERS failures due to defects in materials or workmanship, and DOES NOT COVER normal wear and tear or cosmetic damage. The warranty ALSO DOES NOT COVER damages which occurred in shipment, or failures which are caused by products not supplied by the warrantor, or failures which result from accidents, misuse, abuse, neglect, mishandling, misapplication, alteration, faulty installation, set-up adjustments, misadjustment of consumer controls, improper maintenance, power line surge, lightning damage, modification, or commercial use (such as in a hotel, office, restaurant, or other business), rental use of the product, service by anyone other than a Factory Service Center or other Authorized Servicer, or damage that is attributable to acts of God.

THESE ARE NO EXPRESS WARRANTIES EXCEPT AS LISTED UNDER "LIMITED WARRANTY COVERAGE". THE WARRANTOR IS NOT LIABLE FOR INCIDENTAL OR CONSEQUENTIAL DAMAGES RESULTING FROM THE USE OF THIS PRODUCT, OR ARISING OUT OF ANY BREACH OF THIS WARRANTY.

(As examples, this excludes damages for lost time, travel to and from the servicer, loss of media or images, data or other memory content. The items listed are not exclusive, but are for illustration only.) **ALL EXPRESS AND IMPLIED WARRANTIES, INCLUDING THE WARRANTY OF MERCHANTABILITY, ARE LIMITED TO THE PERIOD OF THE LIMITED WARRANTY.**

Some states do not allow the exclusion or limitation of incidental or consequential damages, or limitations on how long an implied warranty lasts, so the exclusions may not apply to you.

This warranty gives you specific legal rights and you may also have other rights which vary from state to state. If a problem with this product develops during or after the warranty period, you may contact your dealer or Service Center. If the problem is not handled to your satisfaction, then write to the warrantor's Consumer Affairs Department at the addresses listed for the warrantor.

PARTS AND SERVICE WHICH ARE NOT COVERED BY THIS LIMITED WARRANTY ARE YOUR RESPONSIBILITY.

(Continued on next page)

RQTX1122 Limited Warranty (ONLY FOR U.S.A. AND PUERTO RICO)

Customer Services Directory (United States and Puerto Rico)

Obtain Product Information and Operating Assistance; locate your nearest Dealer or Service Center; purchase Parts and Accessories; or make Customer Service and Literature requests by visiting our Web Site at:

<http://www.panasonic.com/help>

or, contact us via the web at:

<http://www.panasonic.com/contactinfo>

You may also contact us directly at: 1-800-211-PANA (7262),
Monday-Friday 9 am-9 pm; Saturday-Sunday 10 am-7 pm, EST.

For hearing or speech impaired TTY users, TTY : 1-877-833-8855

Accessory Purchases (United States and Puerto Rico)

Purchase Parts, Accessories and Instruction Books online for all Panasonic Products by visiting our Web Site at:

<http://www.pstc.panasonic.com>

or, send your request by E-mail to:

npcparts@us.panasonic.com

You may also contact us directly at: 1-800-332-5368 (Phone) 1-800-237-9080 (Fax Only) (Monday – Friday 9 am to 9 pm, EST.)

Panasonic Service and Technology Company

20421 84th Avenue South, Kent, WA 98032

(We Accept Visa, MasterCard, Discover Card, American Express, and Personal Checks)

For hearing or speech impaired TTY users, TTY : 1-866-605-1277

As of October 2008

Limited Warranty (ONLY FOR U.S.A. AND PUERTO RICO)

Limited Warranty (ONLY FOR CANADA)

Panasonic Canada Inc.
5770 Ambler Drive, Mississauga, Ontario L4W 2T3

PANASONIC PRODUCT – LIMITED WARRANTY EXCHANGE PROGRAM

Panasonic Canada Inc. warrants this product to be free from defects in material and workmanship and agrees to replace the product for a period as stated below from the date of original purchase.

Panasonic Portable / Clock Radio (without Tape, CD, MD)	One (1) year
Panasonic Audio Product	One (1) year
Panasonic DVD Product	One (1) year
Accessories including rechargeable batteries	Ninety (90) days

LIMITATIONS AND EXCLUSIONS

This warranty does not apply to products purchased outside Canada or to any product which has been improperly installed, subjected to usage for which the product was not designed, misused or abused, damaged during shipping, or which has been altered or repaired in any way that affects the reliability or detracts from the performance, nor does it cover any product which is used commercially. Dry cell batteries are also excluded from coverage under this warranty.

This warranty is extended to the original end user purchaser only. A purchase receipt or other proof of date of original purchase is required before warranty service is performed.

THIS EXPRESS, LIMITED WARRANTY IS IN LIEU OF ALL OTHER WARRANTIES, EXPRESS OR IMPLIED, INCLUDING ANY IMPLIED WARRANTIES OF MERCHANTABILITY AND FITNESS FOR A PARTICULAR PURPOSE.

IN NO EVENT WILL PANASONIC CANADA INC. BE LIABLE FOR ANY SPECIAL, INDIRECT OR CONSEQUENTIAL DAMAGES.

In certain instances, some jurisdictions do not allow the exclusion or limitation of incidental or consequential damages, or the exclusion of implied warranties, so the above limitations and exclusions may not be applicable.

CONTACT INFORMATION

For product information and operation assistance, please contact:

Our Customer Care Centre:	Telephone #:	(905) 624-5505
	1-800 #:	1-800-561-5505
	Fax #:	(905) 238-2360
	Email link:	"customer support" on www.panasonic.ca

For defective product exchange within the warranty period, please contact the original dealer or our Customer Care Centre.

Limited Warranty (ONLY FOR CANADA)

RQTX1122