

OPERATING INSTRUCTIONS

CF-45 Series



TOUGHBOOK

95

**[Additional Manual]
Reference Manual**

This manual can be accessed on your computer and explains extended measures on how to make greater use of the computer. For information on how to access the Reference Manual, please refer to page 14.

Contents

Getting Started

Read Me First	6
First-time Operation	7

Operation

Starting Up/Shutting Down	11
Usage, Carrying and Maintenance	15

Troubleshooting

Computer Diagnosis	16
Dealing with Problems	17
Reinstalling Software	19

Appendix

LIMITED USE LICENSE AGREEMENT	22
Names and Functions of Parts	24
Specifications	26



Customer's Record	
Model No.* _____	Dealer's Name _____
Serial No. _____	_____
or	
Code No. _____	Dealer's Address _____
Date of Purchase _____	_____

For the Model No., insert the 11 digit number (for example, CF-45NJ48AAM) located on the bottom of the computer.

Introduction

Thank you for purchasing the Panasonic computer. Please read the operating instructions thoroughly for proper operation of your new computer.

Illustrations in this Manual

- NOTE:** **NOTE** provides a useful fact or helpful information.
- CAUTION:** **CAUTION** indicates a condition that may result in minor or moderate injury.
- WARNING:** **WARNING** indicates a hazard that may result in moderate or serious injury.
- [Start]-[Shut Down]: This illustration means to click [Start], then to click [Shut Down].
(For some applications, you may need to double-click.)
- Enter** : This illustration means to press the [Enter] key.
- Fn** + **F5** : This illustration means to press [Fn], and while holding down on [Fn], to press [F5].
-  : Where to go for referred information.
-  Reference Manual : This illustration means to refer to the Reference Manual, which is available on your computer. On how to access the manual, please refer to page 14.

Copyright

This manual is copyrighted by Matsushita Electric Industrial Co., Ltd. with all rights reserved. No part of this manual may be reproduced in any form without the prior written permission of Matsushita Electric Industrial Co., Ltd. No patent liability is assumed with respect to the use of the information contained herein.

©Matsushita Electric Industrial Co., Ltd. 1998. All Rights Reserved.

Disclaimer

Computer specifications and manuals are subject to change without notice. Matsushita Electric Industrial Co., Ltd. assumes no liability for damage incurred directly or indirectly from errors, omissions or discrepancies between the computer and the manuals.

Trademarks

PS/2™ is a trademark of International Business Machines Corporation.

Microsoft®, MS-DOS® and Windows® are registered trademarks of Microsoft Corporation of the United States and/or other countries.

Pentium® is a registered trademark, and MMX™ is a trademark of Intel Corporation.

PhoenixCard Manager™ and Phoenix Card Executive™ are trademarks of Phoenix Technologies Ltd.

Acrobat® is a registered trademark of Adobe Systems Incorporated.

Panasonic® is a registered trademark of Matsushita Electric Industrial Co., Ltd.

For U.S.A.

Federal Communications Commission Radio Frequency Interference Statement

Note: This equipment has been tested and found to comply with the limits for a Class B digital device, pursuant to Part 15 of the FCC Rules. These limits are designed to provide reasonable protection against harmful interference in a residential installation. This equipment generates, uses and can radiate radio frequency energy and, if not installed and used in accordance with the instructions may cause harmful interference to radio communications. However, there is no guarantee that interference will not occur in a particular installation. If this equipment does cause harmful interference to radio or television reception, which can be determined by turning the equipment off and on, the user is encouraged to try to correct the interference by one or more of the following measures:

- Reorient or relocate the receiving antenna.
- Increase the separation between the equipment and receiver.
- Connect the equipment into an outlet on a circuit different from that to which the receiver is connected.
- Consult the Panasonic Service Center or an experienced radio/TV technician for help.

Warning

To assure continued compliance, use only shielded interface cables when connecting to a computer or peripheral. Also, any changes or modifications not expressly approved by the party responsible for compliance could void the user's authority to operate this equipment.

This device complies with Part 15 of the FCC Rules. Operation is subject to the following two conditions:

- (1) This device may not cause harmful interference, and
- (2) This device must accept any interference received, including interference that may cause undesired operation.

Lithium Battery

Lithium Battery!

This computer contains a lithium battery to enable the date, time, and other data to be stored in it.

The battery should only be exchanged by service personnel.

Warning! Risk of explosion from incorrect installation or mis-application!

Warnung bezüglich der Lithiumbatterie (Sicherungsbatterie)

Lithiumbatterie!

Dieser Computer enthält eine Lithiumbatterie zur Sicherung von Datum und Uhrzeit der eingebauten Uhr sowie anderer Systemdaten im Speicher bei einer Unterbrechung der Hauptstromversorgung. Diese Sicherungsbatterie darf nur von Kundendienstpersonal ausgewechselt werden.

Warnung! Bei falschem Gebrauch besteht Explosionsgefahr! Entsorgung gebrauchter Batterien nach Angaben des Herstellers.

Avertissement concernant la pile au lithium (pile de sauvegarde)

Pile au lithium!

Le micro-ordinateur renferme une pile au lithium qui permet de sauvegarder certaines données comme la date et l'heure notamment. Elle ne devra être remplacée que par un technicien qualifié.

Avertissement! Risque d'explosion en cas de non respect de cette mise en garde!

CD-ROM Drive Caution

CAUTION!

THIS PRODUCT UTILIZES A LASER.

USE OF CONTROLS, ADJUSTMENTS OR PERFORMANCE OF PROCEDURES OTHER THAN THOSE SPECIFIED HEREIN MAY RESULT IN HAZARDOUS RADIATION EXPOSURE.

DO NOT OPEN COVERS AND DO NOT REPAIR YOURSELF.

REFER SERVICING TO QUALIFIED PERSONNEL

WARNUNG!

DIESES PRODUKT ERZEUGT LASERSTRAHLUNG.

DURCHFÜHRUNG ANDERER VORGÄNGE ALS DER HIER ANGEGEBENEN KANN ZU GEFÄHRLICHER STRAHLUNG FÜHREN.

REPARATUREN DÜRFEN NUR VON QUALIFIZIERTEM FACHPERSONAL DURCHGEFÜHRT WERDEN.

AVERTISSEMENT!

CET APPAREIL UTILISE UN LASER.

L'UTILISATION DE COMMANDES OU DE RÉGLAGES OU L'EXÉCUTION DE PROCÉDURES AUTRES QUE CELLES SPÉCIFIÉES ICI PEUVENT PROVOQUER UNE EXPOSITION À DES RADIATIONS DANGEREUSES.

NE PAS OUVRIR LES COUVERCLES NI ESSAYER DE RÉPARER SOI-MÊME.

CONFIER TOUT TRAVAIL D'ENTRETIEN À UN PERSONNEL QUALIFIÉ.

Bottom

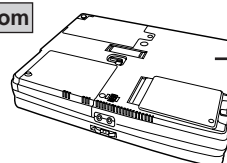

CLASS 1 LASER PRODUCT
LASER KLASSE 1

Precautions

● Usage

Avoid Extreme Heat and Cold

Do not store or use the computer in locations exposed to heat, direct sunlight, or extreme cold.

Avoid moving the computer between locations with large temperature differences.

Operation: 5 °C to 35 °C (41 °F to 95 °F)

Storage: -20 °C to 60 °C (-4 °F to 140 °F)



Avoid Direct Sunlight on the LCD Panel

The LCD panel should not be exposed to direct sunlight or ultraviolet light.



Avoid Humidity, Liquids and Dust

Do not store or use the computer in locations exposed to high humidity, liquids (including rain) or dust.



Prevent Shock

Avoid subjecting the computer to severe vibrations or impact. Do not place the computer inside a car trunk.

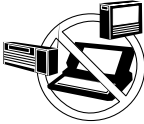

Avoid Radio Frequency Interference

Do not place the computer near a television or radio receiver.

● Handling



Avoid Magnetic Fields

Keep the computer away from magnets.



Avoid Stacking

Do not place heavy objects on top of the computer.



Keep Small Objects Away

Do not insert paper clips or other small objects into the computer.



Do Not Disassemble the Computer

Do not attempt to disassemble your computer.



Avoid Excessive Force on the LCD Panel

Do not apply excessive downward force on the display when it is completely opened, especially when plugs and/or cables are connected to the rear of the computer.

● Peripherals

Incorrectly using peripheral devices may lead to a decrease in performance, an increase in temperature and/or damage your computer. For more information on peripheral devices, please refer to the Reference Manual.

● Cables

Use of an interface cable longer than 3 m (9.84 feet) is not recommended.

Battery Pack Usage

- Care should be exercised with regard to the following in order to avoid the possibility of liquid leakage, overheating, or bursting.



Avoid Heat

Do not throw the battery pack into a fire or expose it to excessive heat.



Keep Articles Away

Do not place the battery pack together with articles such as necklaces or hairpins when carrying or storing.



Do Not Disassemble

Do not insert sharp objects into the battery pack, expose it to bumps or shocks, deform, disassemble, or modify it.



Do Not Short

Do not short the positive (+) and negative (-) contacts.



Avoid Extreme Heat, Cold and Direct Sunlight

Do not charge, use or leave the battery pack for extended periods where it will be exposed to direct sunlight, in a hot place (in an automobile on a sunny day, for example), or in a cold place.



Do Not Use With Other Computer

The battery pack is a rechargeable and was intended for the specified computer or charger. Do not use it with a computer other than the one for which it was designed.



Do Not Put into a Microwave

Do not put the battery into a microwave oven or a pressurized chamber.



Discontinue Use

Should the battery emit an abnormal odor, become hot to the touch, become discolored, change shape, or become in any way different from normal, remove it from the unit or charger and discontinue use.

- Do not touch the terminals on the battery pack. The battery pack may no longer function properly if the contacts are dirty or damaged.
- Do not expose the battery to water, or allow it to become wet.
- If the battery pack will not be used for a long period of time (a month or more), charge the battery pack until the remaining battery level becomes 30% to 50% and store it in a cool, dry place.
- This computer prevents overcharging of the battery by recharging only when the remaining power is less than approx. 95% of capacity.
- The battery pack is not charged when the computer is first purchased. Be sure to charge it before using it for the first time. When the AC adapter is connected to the computer, charging begins automatically.
- Should the battery leak and some of the fluid gets into your eyes, do not rub your eyes. Immediately flush your eyes with clear water and see a doctor for medical treatment as soon as possible.

NOTE

- The battery pack may become warm during recharging or normal use. This is completely normal.
- Recharging will not commence outside of the allowable temperature range (0 °C to 35 °C (32°F to 95 °F)). To allow the battery to charge, adjustments have to be made to the temperature. Once the allowable range requirement is satisfied, charging begins automatically. Note that the recharging time varies based on the usage conditions. (Recharging takes longer than usual when the temperature is 10 °C (48 °F) or less.)
- If the temperature is low, the operating time is shortened. Therefore, please use the computer within the allowable temperature range.
- Although the battery has not begun to run out, the battery indicator may light up red or emit a beep. This indicates a significant rise in the temperature of the battery pack. This is typically caused by the fact that the battery pack has been delivering a high level of power because the computer has been used with the display at the brightest setting and with the power-saving function off.
To protect the battery pack from increases in temperature, the brightness of the display automatically decreases, allowing the temperature of the battery to drop. In this condition, if the computer is left as is, it will automatically go off after about three minutes have elapsed. Within that period, therefore, be sure to connect the AC adapter or shut the computer OFF after saving any open data (if necessary).

Read Me First

Saving Data on the Hard Disk

- **Do not expose your computer to shock.**
Please use care when handling your computer, shock may damage your hard disk or make your software applications and data unusable.
- **Do not power down your computer while software applications are running or HDD indicator (⊞) is on.**
Properly shut Windows* down to avoid problems ([Start]-[Shut Down]).
- **Save all valuable data to floppy disks.**
Backing up data to floppy disks will limit damage should trouble occur to your computer or should you inadvertently change or erase data.
- **Use the security function for all important data.** (☞ Reference Manual "Security Measures")

* This computer uses Microsoft® Windows® 95 Operating System.

Saving Data on Floppy Disks

- **Do not power down your computer or press the floppy disk drive eject button while the FDD indicator (⊞) is on.**
Doing so may damage the data on the floppy disk and render the disk useless.
- **Use care when handling floppy disks.**
To protect the data on your floppy disks or to prevent a floppy disk from becoming stuck in your computer, avoid the following:
 - Sliding the shutter on the floppy disk manually.
 - Exposing the disk to a magnetic field.
 - Storing the disk in locations prone to high temperatures, low pitched noise, dampness, or dust.
 - Applying more than one label on the disk.
- **Confirm the contents of a floppy disk before formatting it.**
Confirm that no important data is on the disk, because all data on the disk will be erased.
- **Use the write-protect tab.**

This is a must for preserving important data. This prevents your data from being erased or overwritten.

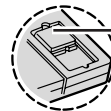

Write Enable

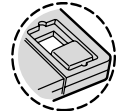

Write Disable

Computer Viruses

- **Users are advised to purchase the latest versions of virus protection software and use them regularly.**

We recommend you run the software:

- When booting your computer.
- After receiving data.

We recommend that you check data received on floppy disks or from external sources, such as data downloaded from the Internet, e-mail, etc. (For compressed files, please uncompress them before running a check).

First-time Operation





Please read the steps below to help you learn what parts are included, and to gain an understanding of some basic computer-related operations.

1 Confirm the inclusion of all parts

Make sure the parts shown in the figure have been supplied. If any of these items are missing or is not working properly, please contact Panasonic Technical Support.

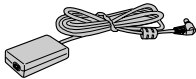
CAUTION

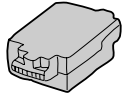
Have 2HD floppy disks prepared to create disks that will allow you to reinstall the operating system should a problem occur. Be sure that these disks are not write-protected. (It is not necessary for these disks to be preformatted.)

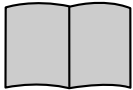
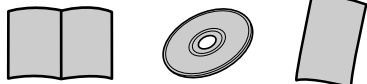
AC Adapter 1  CF-AA1639	AC Cord 1 	Battery Pack ... 1  CF-VZS251AW
FIRSTAID CD 1 	Operating Instructions ... 1 	Windows 95 System Pack 1  Windows® 95 Book CD-ROM Registration Card

2 Connect the battery pack

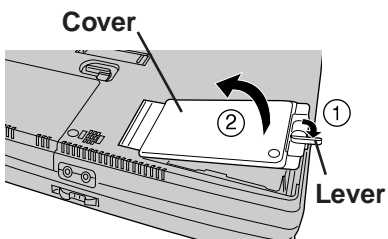

- ① Turn the computer over, unlock the lever then open the cover.

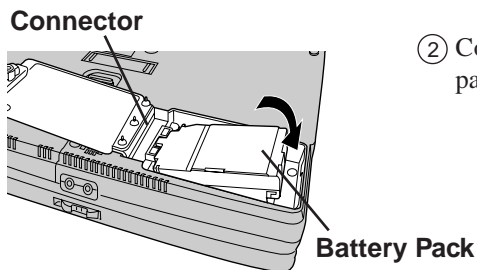

- ② Connect the battery to the connector part, and return it to its proper location.

CAUTION

Be sure the battery pack is properly connected to the connector.

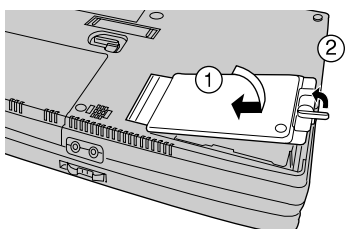

- ③ Put the cover back by using the arrow as a guide. Then, lock the lever into place.

CAUTION

Confirm that the lever lock is correctly in place. Should you decide to carry your computer without the lever lock in place, the cover may open causing the battery pack to fall out.

First-time Operation

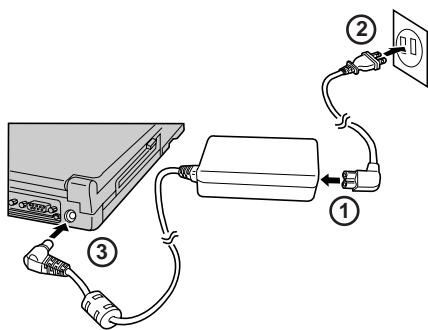

3 Connect your computer to a power outlet

CAUTION

Be sure the AC adapter is connected until completing Step 8 on page 10.

Handling the AC adapter

- Do not twist or pull the AC power cord forcefully. Doing so may damage the connections.
- Use only the specified AC adapter with your computer. Using an AC adapter other than the one supplied might damage the battery and/or the computer.
- When the DC plug is not connected to the computer, disconnect the AC cord from your AC wall outlet well.
- Problems such as sudden voltage drops/surges may arise during periods of thunder and lightning. Since this could adversely affect your computer, an uninterruptible power source (UPS) is highly recommended.

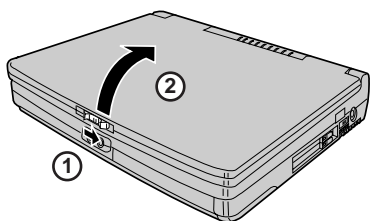

4 Read the LIMITED USE LICENSE AGREEMENT (page 22)

To open the display, slide the latch located at the front and lift open the display. Before removing the seal covering the power switch, please read the LIMITED USE LICENSE AGREEMENT. Removal of this seal indicates agreement to the terms specified. After you have agreed to the terms, you may turn your computer on.

5 Turn your computer on

Slide the power switch toward the rear of the computer and hold it for approximately one second until the power indicator turns on before releasing it.

CAUTION

- Do not slide the power switch and hold it for more than four seconds.
- Do not slide the power switch repeatedly.
- Once the computer is powered off, you must wait at least ten seconds before powering it on again.

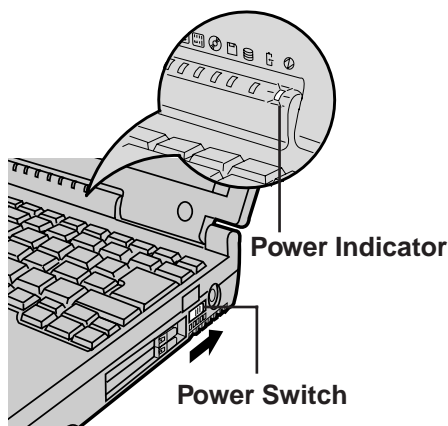

NOTE

The power saving function is factory set to remove power from the LCD if the computer is not operated or no access is made to a device for two minutes. The LCD will resume normal operation if the trackball is moved or if a key on the keyboard is depressed.

6 Set Windows 95 up

- ① Select settings for your region, then press [Next].

NOTE

Moving the cursor (mouse) or clicking buttons can be performed with the trackball (page 12).

- ② Select your keyboard layout, then press [Next].
(for U.S.A.: United States 101)
- ③ Enter your name and your company's name, then press [Next].
(It is possible to omit the company name item.)
The License Agreement will be displayed.
- ④ After reading the agreement, select [I accept the agreement] or [I don't accept the agreement], then press [Next].

NOTE

If [I accept the agreement] is selected, the [Certificate of Authenticity] will appear. If [I don't accept the agreement] is selected, the Windows setup will be aborted.

- ⑤ Input the Product Number written on the "Certificate of Authenticity" located in the Windows® 95 book that comes with this computer then press [Next].
- ⑥ Press [Finish].
- ⑦ Input the correct time, date and time zone and press [Close].
You can also complete these settings at a later time.
- ⑧ If you wish to complete the printer settings, press [Next]. If not, press [Cancel].

NOTE

Simply follow the on-screen instructions. You can also complete these settings at a later time.

- ⑨ Press [Next] to install Internet Explorer. Simply follow the on-screen instructions.



7 Create floppy disks

Prepare 2HD floppy disks and make sure they are not in the write-protected state (for the number to prepare, follow the on-screen instructions). Then, select [Start] - [Programs] - [Panasonic] - [Create FIRST AID FD]. Follow the instructions on the display. After this, place a label on each disk for identification purposes.

Names of created backup disks
FIRST AID FD, Backup Disk*

* There are instances where it is not necessary to create backup disks.

CAUTION

- It may take several minutes to reboot the computer.
- Please store the floppy disks in a safe place. They will enable you to return your computer to factory default settings should any problems occur.
- Do not remove the floppy disk while the FDD indicator () is on, power down your computer or use the suspend function ( ^{Reference Manual} "Suspend / Hibernation Functions").
- When creating floppy disks, do not run any other application program.
- When creating floppy disks and the message [Insufficient files to copy] is displayed, press [OK] and then contact Panasonic Technical Support.

Label-side up
Label on the top surface, and inserting the shutter-side headfirst.

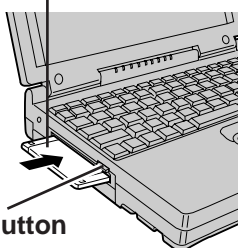

Eject Button

First-time Operation

8 Install the Acrobat® Reader 3.0

- ① In [Start] - [Run], input [c:\util\avapp\reader\setup.exe], then press [OK].
- ② Press [Next] and set up the Acrobat® Reader 3.0.
- ③ After reading the "Software License Agreement", select [Yes] if you agree to the terms.
- ④ Press [Next].
- ⑤ Press [Finish].

NOTE

- Read the [Readme] file as necessary. To close the file, click in the top right corner of the window.
- Use Acrobat® Reader to view the Reference Manual, which explains detailed operational procedures concerning your computer.

- ⑥ Press [OK].

This concludes the first-time use operation guidelines.

Starting Up/Shutting Down

Starting Up

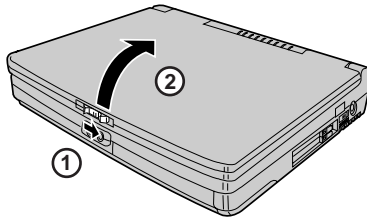

1 Open the display

Slide the latch as shown and lift open the display.

2 Turn your computer on

Slide the power switch toward the rear of the computer and hold it for approximately one second until the power indicator turns on before releasing it.

CAUTION

- The computer will not power on when the LCD panel is closed.
- Do not slide the power switch and hold it for more than four seconds.
- Do not slide the power switch repeatedly.
- Once the computer is powered off, you must wait at least ten seconds before powering it on again.
- If the computer does not power on when the power switch is activated, the CPU temperature may have exceeded its normal operating temperature. In this case, a function designed to prevent it from overheating is triggered automatically and prevents the computer from turning on. Should this happen, allow the computer to cool down then switch the power on again. If the computer still does not turn on, please contact Panasonic Technical Support.
- Do not perform any keyboard or trackball (or mouse) operations until Windows has completely started up.

● If security indicator () is displayed,

you must first enter your User Password ( Reference "Security Measures")

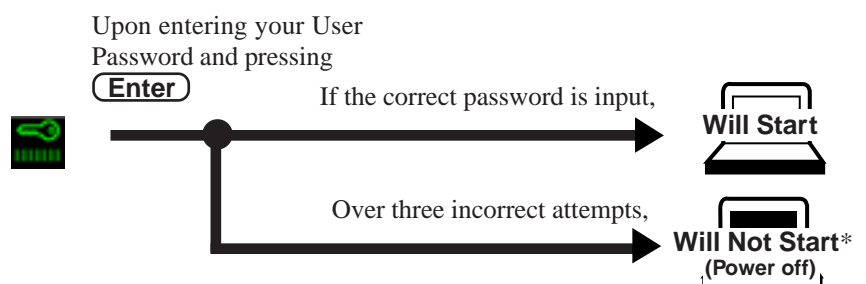

* If you are starting from the suspend mode ( Reference "Suspend / Hibernation Functions"), if after three attempts the correct password is not input, or if no password is entered for about a minute, the computer returns to the suspend mode.

NOTE

If the display on the right appears, The network password has been set. To read and write data to other computers, the correct password must be entered.



● When an application or file that was previously displayed appears on your screen,

The suspend or hibernation mode ( Reference "Suspend / Hibernation Functions") has been set.

Starting Up/Shutting Down

3 Select your application

You are able to start working on your computer.

NOTE

- The power saving function is factory set to remove power from the LCD if the computer is not operated or no access is made to a device for two minutes. The LCD will resume normal operation if the trackball is moved or if a key on the keyboard is depressed.
- [System Devices] in [Device Manager] contains a device bearing an exclamation mark. This does not indicate a malfunction.

Using the Trackball

Use the trackball to move the cursor on the display and perform normal computer operations.

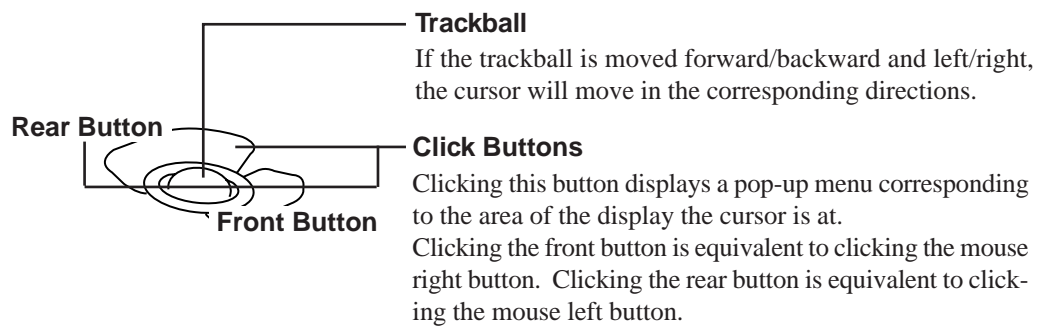

● Basic Operations

Clicking: Simply tap and release a finger on the front or rear button.



Double-clicking: Simply tap and release a finger two times in succession on the front or rear button.



Dragging: While holding down the rear button or front button, spinning the trackball with your fingers.

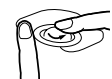

NOTE

- The action of the two buttons vary according to the software application being used. Normally the rear button is used to perform actions.
- To change the settings for the front and rear buttons of the trackball, and the left and right buttons of the mouse, select [Start] - [Settings] - [Control Panel] - [Mouse].

Using the CD-ROM Drive

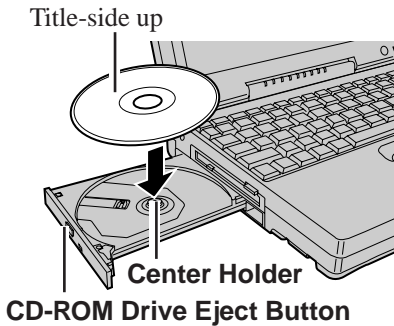

Installing the CD

- 1 Turn your computer on
- 2 Press the CD eject button
- 3 Place the CD securely on the center holder
- 4 Close the tray

CAUTION

- Do not place items other than CDs on the tray.
- Do not leave the tray in the open position. **Also, Do not touch the lens area with your fingers.**
- When the tray is opened, applying too much force to it could cause it to break.
- Do not open the CD-ROM drive or move the computer while an application is in the process of accessing the CD-ROM drive. Doing so could cause it to malfunction.
- Cleaning the CD-ROM drive using a CD lens cleaner (except the liquid type cleaner) is recommended if it malfunctions.
- Do not use the CD-ROM drive in a location where there is a lot of oily smoke or tobacco smoke. Doing so could shorten the service life of the lens.
- Never insert foreign objects such as paper clips into the slot in the CD-ROM drive.
- Do not use CDs that have become deformed (warped, not completely round, etc.).

Shutting Down (power off your computer)

This procedure is shutting down without using the suspend or hibernation function.

1 Display the shutdown screen

After saving important data:

Select [Shut Down] from the [Start] menu.

NOTE

From the keyboard,

You may choose to press down on , then select the menu with  or .

2 Confirm shutdown

Select [Shut down].

Your computer will power off automatically.

(In the OFF state, if you are not recharging your battery pack or if the pack is fully charged, your computer consumes approximately 3.0W.)

● Restarting your computer (without shutting down)

Select [OK] after selecting [Restart].

NOTE

To quickly resume computer operation after shutting down,

The suspend or hibernation function is available( Reference Manual "Suspend / Hibernation Functions")

Starting Up/Shutting Down

About the "Reference Manual"

The Reference Manual can be accessed on your computer. When a printer is connected, it is also possible to print out the manual.

This manual explains functions for you to make greater use of the computer, such as how to add peripheral devices, how the Setup Utility works and other useful information.

CAUTION

When you read the "Reference Manual", it is necessary to install the Acrobat Reader 3.0. (☞ page 10)

Run the Reference Manual

1 Turn your computer on

2 Select [Reference Manual] in [Start] - [Program] - [Panasonic]

Zoom-In: Go forward or back a page, or to the beginning or end of a document

Hand Tool: To move around the current page.

Cancel or correct an operation

Change the display size

Do a "find" operation

Exit

Table of Content (Items): By clicking an item, the corresponding page will be displayed.

Display of the manual

(The display varies depending on the models.)

Change the display size: You can choose to magnify/de-magnify the display.

Page indicator: A desired page can be displayed by inputting the page number.

Movable splitter bar: This bar can be dragged, for example, to the right to enlarge the display of the Table of Contents.

Contents	
Key Combinations	2
LED Indicators	3
Suspend/Hibernation Functions	4
Security Measures	7
Computing On the Road	11
Battery Power	13
Using PC Cards	15
Adding Memory	17
Port Replicator	18
Using a Printer	19
Using an External Display	20
Using USB Devices	21

CAUTION

- Illustrations may be difficult to view depending on the magnification. If this is the case, we recommend that the display be magnified.
- When the taskbar is hidden at the bottom portion of Acrobat® Reader, set the maximum display window size.
- If a printer is connected, we recommend printing the Reference Manual. The illustrations and display samples may not print with a high quality.

Usage, Carrying and Maintenance

Usage Environment

● Environment

- Place the computer on a flat stable surface.
- In use: Temperature: 5 °C to 35 °C (41 °F to 95 °F)
Humidity: 30% to 80% RH (No condensation)
- Not in use: Temperature: -20 °C to 60 °C (-4 °F to 140 °F)
Humidity: 30% to 90% RH (No condensation)

● Places not to use your computer

- Such areas may result in damage to the computer.
Areas exposed to direct sunlight

Areas with electronic equipment

These areas may interfere with your display or cause your computer to produce strange sounds.

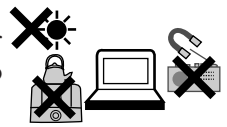

Areas with extremely high/low temperatures

- Do not leave things near the computer that are sensitive to heat. During operation, the computer can become quite hot.

Transporting

- It is a good idea to make backup copies on floppy disks and carry them with you.
- Do not leave a floppy disk in the drive while transporting your computer.
- Do not carry your computer when it is ON.
- Remove all cables before transporting your computer.
- We recommend preparing a fully charged battery (and optional charger, if possible).
When transporting spare batteries inside a package, briefcase, etc., it is recommended that the batteries be stored in a plastic bag.
- Do not carry the computer while the display is open, or carry it by gripping the display.
- Do not put anything (e.g., a piece of paper) between the display and keyboard.
- Do not drop or hit your computer against solid objects.
- Always carry your computer with you. Never check it with luggage. For use of the computer inside an aircraft, we recommend asking the airlines regarding their policy on this issue.

Maintenance

Areas excluding the display:

Wipe these areas with a soft cloth, after applying water or detergent diluted with water to the soft cloth and firmly wringing it.

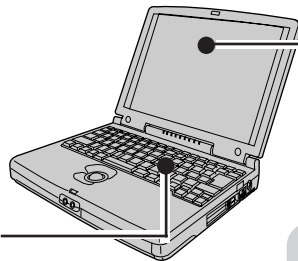

Display:

Use a soft dry cloth like gauze to lightly wipe the display.

CAUTION

- Do not use benzene or thinner, or disinfectant-type alcohol.
- Do not directly use water, liquid detergents or spray-type cleaners. If liquid enters the computer, this may cause the computer to malfunction or become defective.

CD-ROM

- Do not allow CDs to become dirty or scratched.
- Do not place or store CD in locations exposed to heat, direct sunlight, humidity or dust.
- Do not write on the surface of the CD with a ball-point pen or other writing instrument, or apply label on the CD.
- Do not drop, bend, or place heavy objects on top of CDs.
- If the CD is brought from a cold into a warm environment, moisture may form on the disc. Wipe this moisture off with a soft, dry, lint-free cloth before using the CD.
- Cleaning the CD using a CD disk cleaner (LF-K022DC) is recommended once every 2 or 3 months.

After wiping the CD with a moist, soft cloth, wipe it with a dry cloth. Always wipe from the center toward the edge.

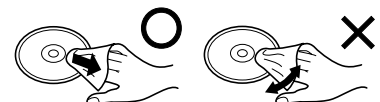

Computer Diagnosis

List of Error Codes

If a problem occurs with your hardware, and [POST Start up Error(s)] is displayed along with the error code(s), follow the on-screen instructions.

Setup: Setup Utility (☞ ^{Reference} _{Manual} "Setup Utility") is started. Run [Load Default Settings (PnP)]. Rerun the Setup Utility to input the appropriate operating environment settings.

Exit: Ignore the error message(s), and restart the computer.

Code	Description
062	Boot failure--default configuration used
101	System Board Failure
102	System Board Failure
106	System Board Failure
114	Adapter ROM Error
151	System Board Failure
161	Bad CMOS Battery
162	Configuration Change Has Occurred
162	Configuration Error
163	Date and Time Incorrect
173	Configuration Change Has Occurred
201	Memory Size Error
301	Keyboard Error
303	Keyboard Error
604	Diskette Drive Error
605	Diskette Drive Error
1780	Hard Disk Error
1800	PCI Error
1801	PCI Error
1802	PCI Error
1803	PCI Error
1804	PCI Error
1805	PCI Error
1962	
8603	Pointing Device Error
I9990301	
I9990305	

Using the Self-diagnosis Program

Follow the procedure below to check whether each part of your computer is operating properly.

- 1** To run the program, insert the FIRST AID FD you created into the floppy disk drive, then turn your computer on
- 2** Select [1] from the menu
- 3** At the MS-DOS prompt (A:\WINDOWS\COMMAND>), input the following:
diag45 (Enter)

Follow the messages on the screen.

Dealing With Problems

When a problem occurs, please refer to this page. The "Reference Manual" also contains detailed information. If a problem appears to be related to a software application, read the software related manual. If you still cannot troubleshoot the problem, please contact Panasonic Technical Support.

● Starting Up

The power indicator or battery indicator is not lit	<ul style="list-style-type: none"> ● Check the cable connection for the AC adapter. ● Check to see if a fully charged battery is properly installed. ● Pressing the reset button (☞ page 24) will solve the problem. ● Remove the battery pack and disconnect the AC adapter, then connect them again.
 is displayed	Please input your password. If you have forgotten it, contact Panasonic Technical Support.
[POST Start Up Error(s)] is displayed	☞ page 16
The pre-memory count, Windows startup, or an operation is extremely slow	Run [Load Default Settings] (PnP) in the Setup Utility (☞ <small>Reference Manual</small> "Setup Utility"). This will restore the Setup Utility's settings to their default values (except the password settings). Then, the Setup Utility must be run once again for you to input the appropriate operating environment settings. (The processing speed depends on the application software used, so this operation may not cause the processing speed to increase.)
The date and time are incorrect	<ul style="list-style-type: none"> ● You can set the date and time through [Date/Time] in [Start] - [Settings] - [Control Panel]. If you continue to experience problems, the internal battery maintaining the clock may need to be replaced. Please contact Panasonic Technical Support.
When the previous item is not the cause	<ul style="list-style-type: none"> ● Run [Load Default Settings] (PnP) in the Setup Utility (☞ <small>Reference Manual</small> "Setup Utility"). This will restore the Setup Utility's settings to their default values (except the password settings). ● Try removing all peripheral devices. ● In the MS-DOS mode, run SCANDISK to check the hard disk. ● At start-up, press (F8) to operate the computer in the Safe mode.

● Battery Indicator

The red battery indicator lights. Repeated beeps sound while the computer is in use.	The battery level is low. Save your data and power off your computer. After connecting the AC adapter or replacing the battery pack with a fully charged one, turn your computer on.
The red indicator blinks	<ul style="list-style-type: none"> ● The battery pack or recharging function may be defective. Quickly remove the battery pack and disconnect the AC adapter, then connect them again. ● If the problem persists, contact Panasonic Technical Support.
After the AC adapter is connected, the orange indicator blinks five times	Unable to charge because of an improper temperature range.

● Character Input

Unable to input anything but numerals	If NumLk and Key Pad are on, the Numeric Key Pad is ON. To switch it OFF, press (Fn) + (Key Pad) .
Only capital letters are being input	If CapsLock is on, the Caps Lock function is ON. To switch it OFF, press (Caps Lock) .
How to input European characters (ß, à, ç) or symbols is unclear	Select [Start] - [Programs] - [Accessories] - [Character Map]. The Character Map will be displayed. Point to the desired font name and select it.

Dealing with Problems

● Display

No display after powering on	<ul style="list-style-type: none"> ● At the time of purchase, the display setting is preset for an external display. If you connect an external display, the screen is displayed on the external display. ● When there is no display to an external display, <ul style="list-style-type: none"> • Check your cable connection to the external display. • Confirm your display is powered on. • Check the settings for your external display. ● Try changing the display by pressing (Fn) + (F3) ● If your computer is connected to an external display and the internal LCD has been set to "off", and the computer is placed in the hibernation or suspend mode, the internal LCD will remain in the "off" mode if the external display is not connected when the computer is restarted. In this case, re-connect the external display and reboot the computer.
The power has not been cut, but after a certain period of time, there is no display	<ul style="list-style-type: none"> ● Has the computer been set to the power-saving mode? To resume operation of your computer, press any key, or move the trackball or mouse. ● To save power, your computer may have automatically entered the suspend or hibernation mode. (☞ <small>Reference Manual</small> "Suspend / Hibernation Functions")
An afterimage appears	If an image is displayed for a prolonged period of time, an afterimage may appear. This is not a malfunction. The afterimage will disappear when a different screen is displayed.
The motion of the mouse cursor is not smooth	Select [Start]-[Settings]-[Control Panel]-[Mouse]-[Motion] and check [Show pointer trails].

● Disk Operations

Cannot read/write to a floppy disk	<ul style="list-style-type: none"> ● Has the floppy disk been correctly inserted? ● Has the floppy disk been correctly formatted? ● Has the Setup Utility been used to set [Floppy Operation] to [Enable]? (☞ <small>Reference Manual</small> "Setup Utility")
Unable to write to a floppy disk	Is the floppy disk write-protected?
How to format a floppy disk is unclear	Select [Format] in [My Computer] - [3 1/2 Floppy (A:)] - [File]. After confirming the disk volume and format type, start formatting.
Unable to read/write to the hard disk	<ul style="list-style-type: none"> ● Your drive or file may not have been properly set. ● Check to see if the hard disk is full. If it is full, delete unnecessary files. ● Your hard disk content may be corrupted. Contact Panasonic Technical Support.
Trouble has occurred with the CD	You may need to clean the lens or CD; refer to (☞ page 16) on how to do so.
When the previous item is not the cause	Try testing another drive or media.
The access lamp (Ⓛ) does not light	Is the CD loaded on the tray correctly?
Cannot play CD or read data from it	Is the CD bent, scratched, or dirty?
Cannot eject CD	<p>Is the computer powered on?</p> <p>To remove a CD when the computer is powered off, insert a sharp object such as the bent-out tip of a paper clip into the emergency hole. Pushing it completely to the end will free the tray so that it can be pulled out.</p>
The CD-ROM drive vibrates a lot	Is the CD bent or labeled?

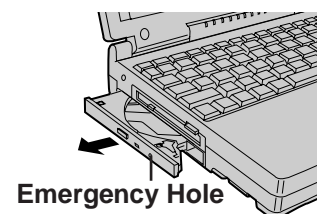

Reinstalling Software

Before Reinstallation

● Preparing

- You will need the FIRSAID CD, CD-ROM included in the Windows 95 System Pack and the FIRSAID FD you made earlier.

NOTE

If you have not created the FIRSAID FD, you can create by selecting [Create FIRSAID FD] in [Start]-[Programs]-[Panasonic]. If for some reason, you do not have this disk or it is corrupted, please contact Panasonic Technical Support.

● Important

- Save all important data. If reinstallation is carried out, all data existing prior to the installation will be lost. The reinstallation will return the computer to factory condition.
- Be sure to remove all PC Cards and disconnect all peripherals before the reinstallation procedure.
- Be sure the AC adapter is connected until completing reinstallation.

Reinstalling

● Windows 95 (HDD format)

CAUTION

If data on your hard disk is compressed, the data should be uncompressed.

- 1 Insert the FIRSAID FD, and turn the computer on; this screen should appear.

```
Microsoft Windows 95 Startup Menu
-----
1. Boot
2. Initialize the HDD for the Hibernation function
3. Restore the HDD to factory default

Enter a choice: 1
```

- 2 You can choose to create the hibernation domain. To use the hibernation function, follow this procedure and be sure to create the hibernation domain. (If you decide not create this domain, after restarting the computer, go on to step ④.)
 - ① Select [2.Initialize the HDD for the Hibernation function].
 - ② At the confirmation message, press **(Y)**.
 - ③ When the message [Press any key to continue...] is displayed, confirm that the FIRSAID FD has been set in the floppy drive, and then press a key. The computer will reboot.
 - ④ When the message [Press F1 for Setup] is displayed, press **(F1)** and then run the Setup Utility.
 - ⑤ Select [Load Default Settings (PnP)], then press **(Enter)**.
At the confirmation message, press **(Enter)**.
 - ⑥ In [Power Management], set [Power Switch] to [On-Off] and set [Power Saving] to [OFF], press **(Esc)**.
 - ⑦ Set [USB Controller] in [Supervisor Setup] to [Enable], press **(Esc)**.
 - ⑧ Save the settings and then close the Setup Utility. The computer will reboot, and will then return to the display shown in step 1.

● Windows 95 (reinstalling)

- 3 Select [3. Restore the HDD to factory default].
- 4 At the confirmation message, press any key.
- 5 When your computer prompts you to insert the FIRSAID CD, please set the specified CD and press any key.
- 6 When your computer prompts you to insert the "Windows 95 CD-ROM", please set the specified CD and press any key.
- 7 When the [To continue, press Enter...] appears, press **(Enter)**.
After Microsoft ScanDisk completes, the computer will automatically return to the Windows 95 setup. Simply follow the on-screen instructions .

NOTE

- With the exception of the instruction below, please select all default values displayed by the Setup Wizard. Be sure to add the check mark to [Sound, MIDI, or Video Capture Card] at the [Analyzing Your Computer].
 - Have a floppy disk on hand to create a "Windows 95 Startup Disk". Immediately after creating this disk, enter the FIRSAID FD into the floppy disk drive and press [OK]. (Note: A system error will result if the FIRSAID FD is not inserted. If this occurs, insert the FIRSAID FD and press [Retry].)
- 8 At the [Finishing Setup], remove the floppy disk and press [Finish]. Windows will restart after all the settings have automatically been made.
 - 9 At the [Date/Time Properties], press [Close].
 - 10 At the [Add Printer Wizard], press [Cancel].
 - 11 When the display appears indicating the establishment of the system settings, press [OK]. The computer will reboot.

Reinstalling Software

● System setup

- 12 In [Start] - [Run], input [c:\install.bat], then press [OK]. Rebooting will be done automatically. It may take several minutes to reboot the computer.
- 13 In [Start] - [Programs] - [Windows Explorer], delete the "c:\install.bat" and "c:\install.pif" files.

● Device Manager 1

- 14 In [Start] - [Settings] - [Control Panel] - [System] - [Device Manager], select [PCIC or compatible PCMCIA controller] in [PCMCIA socket]. Remove the check for [Disable in this hardware profile] in [Properties] - [General] and then press [OK].
- 15 Press [Next] at the display for the [Display Driver Wizard for PC Cards (PCMCIA)], press [Next] again and then press [Finish].
- 16 When the message appears asking whether to reboot the computer, select [No].
- 17 Check [View devices by connection] at [Device Manager] and select [PCI bus] in [Plug and Play BIOS], press [Remove], then press [OK]. The display will ask you to restart Windows, press [Yes]. Rebooting will be done automatically. If the computer asks you to insert the Windows 95 CD-ROM, press [OK]. Input [c:\cabs], then press [OK].
 - Then, when the [Version Conflict] appears, select [Yes].
- 18 Press [Next] at the [Update Device Driver Wizard of PCI Universal Serial Bus] and [Finish].
- 19 Press [Next] at the [Update Device Driver Wizard of Standard PCI Graphics Adapter (VGA)] and [Finish]. The display will ask you to restart Windows, press [Yes]. (at times, the message may appear a few times)

● Sound driver

- 20 In [Control Panel] - [System] - [Device Manager], for each item in [Sound, video and game controller], press [Remove] to delete it, then press [OK] to confirm the deletion.
- 21 Press [Refresh] and press [Next] at the [Update Device Driver Wizard of Unknown Devices].
- 22 Select [Other Locations], input [c:\util\drivers\sound], then press [OK].
- 23 At the [Update Device Driver Wizard of YAMAHA OPL3-SAx], press [Finish].

● Video Driver

- 24 In [Device Manager] - [Display adapters] - [Standard PCI Graphics Adapter (VGA)] - [Driver] - [Update Driver], select [Yes (Recommended).], then press [Next].
- 25 Select [Other Locations], input [c:\util\drivers\video], press [OK], then press [Finish]. The display will ask you to restart Windows; remove the floppy disk and press [Yes].

● Power Management

- 26 Delete the check mark ✓ for [When powered by AC power] and [When powered by batteries] in [Start] - [Settings] - [Control Panel] - [Power] - [Disk Drives], then press [OK].

● Device Manager 2

- 27 Add the check mark ✓ for [DMA] in [Control Panel] - [System] - [Device Manager] - [CDROM] - [TEAC CD-220EA] - [Settings].
- 28 Set [L:] for [Reserved drive letters], then press [OK].
- 29 Add the check mark ✓ for [DMA] in [Device Manager] - [Disk drives] - [GENERIC IDE DISK TYPE**] - [Settings], then press [OK].
- 30 Set [Mobile or docking system] in [System] - [Performance] - [File System] - [Hard Disk] - [Typical role of this machine], then press [OK].
- 31 At the [System Properties], press [Close]. The display will ask you to restart Windows, then press [Yes].

● Display Driver

- 32 Select [Super VGA 1024 X 768] for [Models] in [Control Panel] - [Display] - [Settings] - [Advanced Properties] - [Monitor] - [Change], then press [OK].
- 33 Confirm that there is a check mark for [Automatically detect Plug & Play monitor] in [Options] for the [Monitor], and then press [Close].
- 34 Set [True Color (24 bit)] for the [Color palette], set [800 by 600 pixels] for the [Desktop area] and then press [OK].
 - When [Compatibility Warning] is displayed, press [OK].

● Tone and Volume adjustment

- 35 Select [Control Panel] - [OPL3-SAx Config], increase both the Treble and Bass in [Tone Control] by two orders and then press [OK].
- 36 Select  on the taskbar, set the maximum volume.
- 37 Decrease the volume by pressing **(Fn) + (F5)** twice.

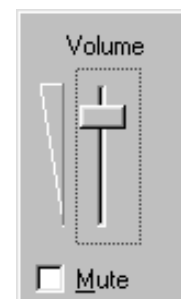

● DMI Viewer setup

- 38 Insert the FIRSTAI CD.
- 39 In [Start] - [Run], input [L:\en\dm\setup.exe], then press [OK].
DMI Viewer setup will start automatically. Simply follow the on-screen instructions. The display will ask you to restart Windows; press [Yes].

● Infrared

- 40 Select [Control Panel] - [Add New Hardware].
- 41 Press [Next] at the [Add New Hardware Wizard].
- 42 Select [No], then press [Next].
- 43 Select [Infrared] in [Hardware types] and press [Next].
- 44 Press [Next], and press [Next] again.
- 45 Select [Generic Ir Serial Port[COM2]] in [Select the port that infrared device...].
- 46 From here on, follow the instructions given on the display followed by pressing [Next].
If the computer asks you to insert the Windows 95 CD-ROM, press [OK]. Input [c:\cabs], then press [OK].
- 47 Press [Finish].

Installing USB

- 1 Insert the Windows 95 CD-ROM.
- 2 In [Start] - [Run], input [L:\other\updates\usb\usbsupp.exe], then press [OK].
At the confirmation message, press [Yes].
- 3 Read the [END-USER LICENSING AGREEMENT] and press [Yes] or [No].
 - Installation will start if [Yes] is pressed. A message will appear asking whether to restart the computer; press [OK].
 - Installation will be aborted if [No] is pressed.
- 4 At the display indicating the completion of installation, press [OK]. The computer will automatically restart.
- 5 In [Start] - [Run], input [L:\other\updates\usb\usbupd2.exe], then press [OK].
- 6 In [Start] - [Shut Down], select [Restart the computer], then press [OK].
- 7 In [Start] - [Run], input [c:\util\msupdate\usbcopy.bat], then press [OK].
- 8 Click at the upper right corner to close the display.
- 9 In [Start] - [Settings] - [Control Panel] - [System] - [Device Manager], select [PCI Universal Serial Bus] in [Other devices], press [Remove], then press [OK].
- 10 Press [Refresh].
- 11 At the [System Properties], press [Close].
- 12 In [Start] - [Shut Down], select [Restart the computer], then press [OK].
- 13 When the message [Press F1 for Setup] is displayed, press **F1** and then run the Setup Utility.
- 14 Set [USB Controller] in [Supervisor Setup] to [Disable], press **Esc**.
- 15 Save the settings and then close the Setup Utility.

Installing Internet Explorer 4.0

Reinstalling Windows causes an older version of Internet Explorer to be installed.

To return the computer to the state it was in when you purchased it, follow the steps below to install the newer version of Internet Explorer.

- 1 Insert the Windows 95 CD-ROM included in the Windows 95 System Pack.
- 2 In [Start] - [Run], input [L:\win95\ie4setup.exe], then press [OK]. Follow the on-screen instructions. The display will ask you to restart Windows, then press [Yes].

Installing Acrobat Reader 3.0

☞ page 10, Step 8

LIMITED USE LICENSE AGREEMENT

THE SOFTWARE PROGRAM(S) ("PROGRAMS") FURNISHED WITH THIS PANASONIC® PRODUCT ("PRODUCT") ARE LICENSED ONLY TO THE END-USER ("YOU"), AND MAY BE USED BY YOU ONLY IN ACCORDANCE WITH THE LICENSE TERMS DESCRIBED BELOW. YOUR USE OF THE PROGRAMS SHALL BE CONCLUSIVELY DEEMED TO CONSTITUTE YOUR ACCEPTANCE OF THE TERMS OF THIS LICENSE.

Matsushita Electric Industrial Co., Ltd. ("MEI") has developed or otherwise obtained the Programs and hereby licenses their use to you. You assume sole responsibility for the selection of the Product (including the associated Programs) to achieve your intended results, and for the installation, use and results obtained therefrom.

LICENSE

- A. MEI hereby grants you a personal, non-transferable and non-exclusive right and license to use the Programs in accordance with the terms and conditions stated in this Agreement. You acknowledge that you are receiving only a LIMITED LICENSE TO USE the Programs and related documentation and that you shall obtain no title, ownership nor any other rights in or to the Programs and related documentation nor in or to the algorithms, concepts, designs and ideas represented by or incorporated in the Programs and related documentation, all of which title, ownership and rights shall remain with MEI or its suppliers.
- B. You may use the Programs only on the single Product which was accompanied by the Programs.
- C. You and your employees and agents are required to protect the confidentiality of the Programs. You may not distribute or otherwise make the Programs or related documentation available to any third party, by time-sharing or otherwise, without the prior written consent of MEI.
- D. You may not copy or reproduce, or permit to be copied or reproduced, the Programs or related documentation for any purpose, except that you may make one (1) copy of the Programs for backup purposes only in support of your use of the Programs on the single Product which was accompanied by the Programs. You shall not modify, or attempt to modify, the Programs.
- E. You may transfer the Programs and license them to another party only in connection with your transfer of the single Product which was accompanied by the Programs to such other party. At the time of such a transfer, you must also transfer all copies, whether in printed or machine readable form, of every Program, and the related documentation, to the same party or destroy any such copies not so transferred.
- F. You may not remove any copyright, trademark or other notice or product identification from the Programs and you must reproduce and include any such notice or product identification on any copy of any Program.

YOU MAY NOT REVERSE ASSEMBLE, REVERSE COMPILE, OR MECHANICALLY OR ELECTRONICALLY TRACE THE PROGRAMS, OR ANY COPY THEREOF, IN WHOLE OR IN PART.

YOU MAY NOT USE, COPY, MODIFY, ALTER, OR TRANSFER THE PROGRAMS OR ANY COPY THEREOF, IN WHOLE OR IN PART, EXCEPT AS EXPRESSLY PROVIDED IN THE LICENSE.

IF YOU TRANSFER POSSESSION OF ANY COPY OF ANY PROGRAM TO ANOTHER PARTY, EXCEPT AS PERMITTED IN PARAGRAPH E ABOVE, YOUR LICENSE IS AUTOMATICALLY TERMINATED.

TERM

This license is effective only for so long as you own or lease the Product, unless earlier terminated. You may terminate this license at any time by destroying, at your expense, the Programs and related documentation together with all copies thereof in any form. This license will also terminate effective immediately upon occurrence of the conditions therefor set forth elsewhere in this Agreement, or if you fail to comply with any term or condition contained herein. Upon any such termination, you agree to destroy, at your expense, the Programs and related documentation together with all copies thereof in any form.

YOU ACKNOWLEDGE THAT YOU HAVE READ THIS AGREEMENT, UNDERSTAND IT AND AGREE TO BE BOUND BY ITS TERMS AND CONDITIONS. YOU FURTHER AGREE THAT IT IS THE COMPLETE AND EXCLUSIVE STATEMENT OF THE AGREEMENT BETWEEN US, WHICH SUPERSEDES ANY PROPOSAL OR PRIOR AGREEMENT, ORAL OR WRITTEN, AND ANY OTHER COMMUNICATIONS BETWEEN US, RELATING TO THE SUBJECT MATTER OF THIS AGREEMENT.

Contrat de licence d'usage limité

Le(s) logiciel(s) (les "Logiciels") fournis avec ce produit Panasonic® (le "Produit") sont exclusivement concédés en licence à l'utilisateur ultime ("vous"), et ils ne peuvent être utilisés que conformément aux clauses contractuelles ci-dessous. En utilisant les logiciels, vous vous engagez de manière définitive à respecter les termes, clauses et conditions des présentes.

Matsushita Electric Industrial Co., Ltd. ("MEI") a mis au point ou obtenu les Logiciels et vous en concède l'utilisation par les présentes. Vous assumez l'entière responsabilité du choix de ce Produit (y compris des Logiciels associés) pour obtenir les résultats escomptés, ainsi que de l'installation, de l'utilisation et des résultats obtenus.

Licence

- A. MEI vous octroie par les présentes le droit et la licence personnels, non cessibles et non exclusifs d'utiliser les Logiciels conformément aux termes, clauses et conditions de ce Contrat. Vous reconnaissez ne recevoir qu'un droit limité d'utiliser les Logiciels et la documentation les accompagnant et vous vous engagez à n'obtenir aucun droit de titre, propriété ni aucun autre droit vis-à-vis des Logiciels et de la documentation les accompagnant ni vis-à-vis des algorithmes, concepts, dessins, configurations et idées représentés par ou incorporés dans les Logiciels et la documentation les accompagnant, dont les titres, propriété et droits resteront tous à MEI ou à leurs propriétaires.
- B. Vous ne pouvez utiliser les Logiciels que sur le Produit unique qui est accompagné par les Logiciels.
- C. Vous et vos employés ou agents êtes requis de protéger la confidentialité des Logiciels. Vous ne pouvez ni distribuer ni mettre les Logiciels et la documentation les accompagnant à la disposition d'un tiers, par partage de temps ou de quelque autre manière que ce soit, sans l'autorisation écrite préalable de MEI.
- D. Vous ne pouvez ni copier ni reproduire ni permettre la copie ni la reproduction des Logiciels ni de la documentation les accompagnant pour quelque fin que ce soit, à l'exception d'une (1) copie des Logiciels à des fins de sauvegarde uniquement pour soutenir votre utilisation des Logiciels sur le Produit unique qui est accompagné par les Logiciels. Vous ne pouvez ni modifier ni tenter de modifier les Logiciels.
- E. Vous ne pouvez céder les Logiciels et en octroyer la licence à une autre partie qu'en rapport avec votre cession du Produit unique qui est accompagné par les Logiciels à cette autre partie. Au moment de cette cession, vous devez céder également toutes les copies, que ce soit sous forme imprimée ou lisible par la machine, de tous les Logiciels ainsi que de la documentation les accompagnant, à la même partie ou détruire les copies non cédées.
- F. Vous ne pouvez retirer aucune marque de droits d'auteur, marque ou autre ni aucune identification de produit des Logiciels et vous devez reproduire et inclure toutes ces notices ou identifications de produit sur toutes les copies des Logiciels.

Vous ne pouvez assembler en sens inverse, compiler en sens inverse ni retracer les Logiciels ni aucune de leurs copies, de façon électronique ou mécanique, en tout ou en partie.

Vous ne pouvez utiliser, copier, modifier, altérer ni céder les Logiciels ni aucune de leurs copies, en tout ou en partie, à l'exception de ce qui est expressément stipulé dans ce contrat.

Si vous cédez la possession de toute copie ou de tout Logiciel à une autre partie, à l'exception de ce qui est autorisé au paragraphe E ci-dessus, votre licence est automatiquement résiliée.

Termes, clauses et conditions

Cette licence n'est effective que pour la durée de possession ou de crédit-bail du Produit, à moins d'une résiliation antérieure. Vous pouvez résilier cette licence à tout moment en détruisant, à vos frais, les Logiciels et la documentation les accompagnant avec toutes leurs copies, sous quelque forme que ce soit. Cette licence sera également résiliée, avec application immédiate, si les conditions de résiliation définies ailleurs dans ce contrat se sont réalisées ou si vous ne respectez pas les termes, clauses et conditions qui y sont contenues. Au moment de la résiliation, vous acceptez de détruire, à vos frais, les Logiciels et la documentation les accompagnant avec toutes leurs copies, sous quelque forme que ce soit.

Vous reconnaissez avoir lu ce contrat, en avoir compris toute la substance et avoir accepté de respecter ses termes, clauses et conditions. Vous reconnaissez en outre qu'ils sont la description complète et exclusive du contrat conclu entre nous, contrat qui remplace et annule toute proposition ou contrat précédent, écrit ou oral, et toute autre communication entre nous, relativement à l'objet du présent contrat.

Names and Functions of Parts

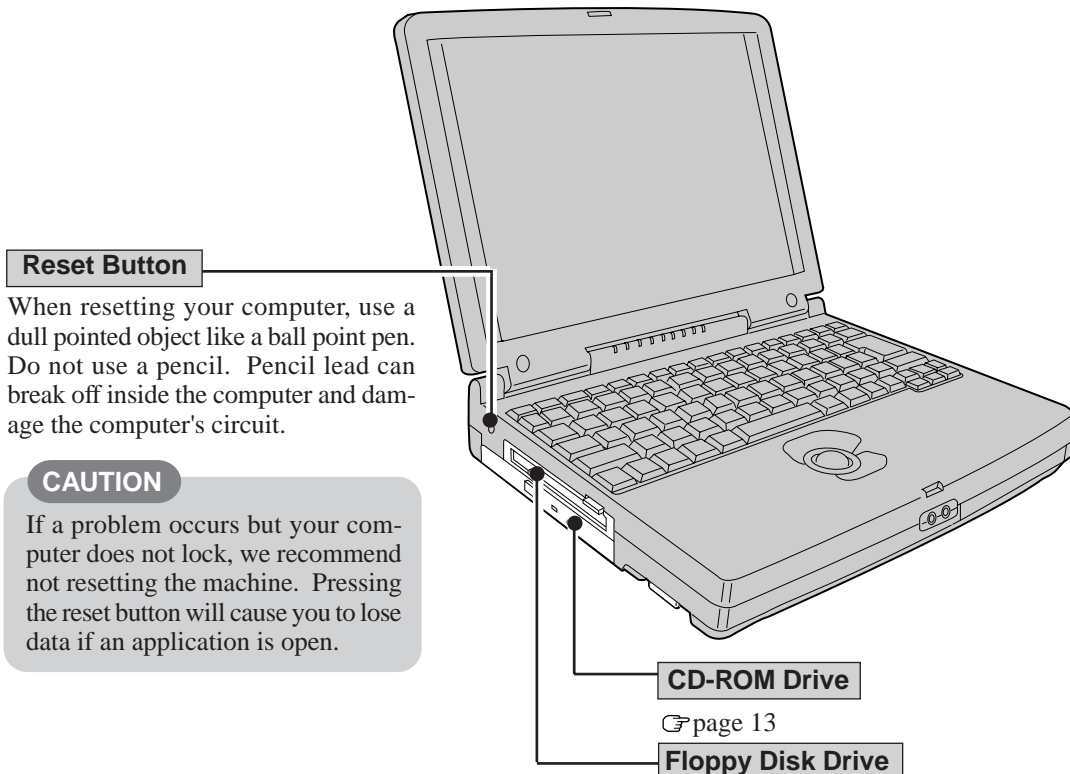
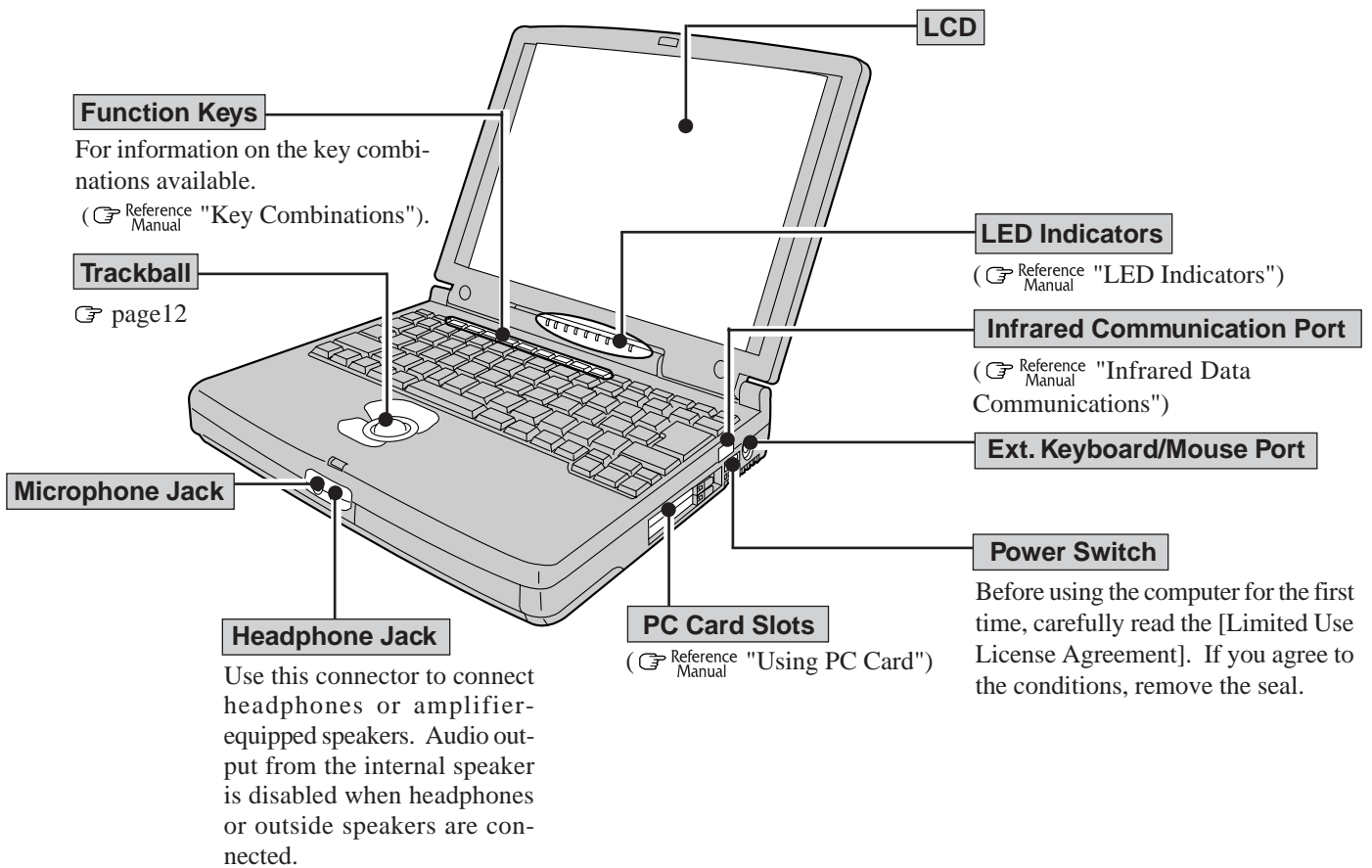

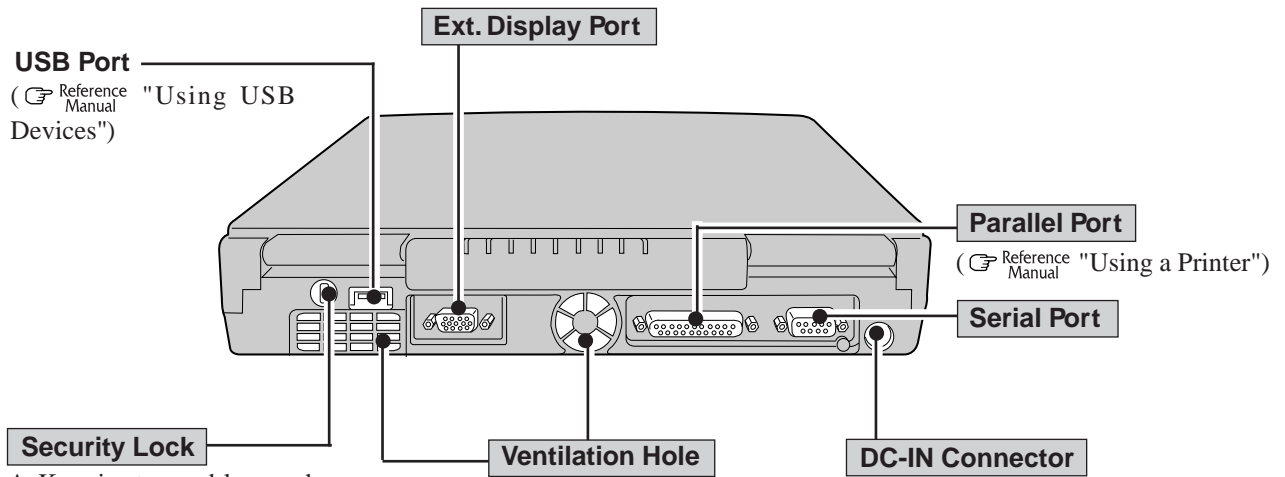



Security Lock
A Kensington cable can be connected to prevent theft of your computer. For more information, please read the manual that comes with the cable.

These holes allow heat to exit.

CAUTION
Do not block or place the computer in a location that may prevent proper ventilation.

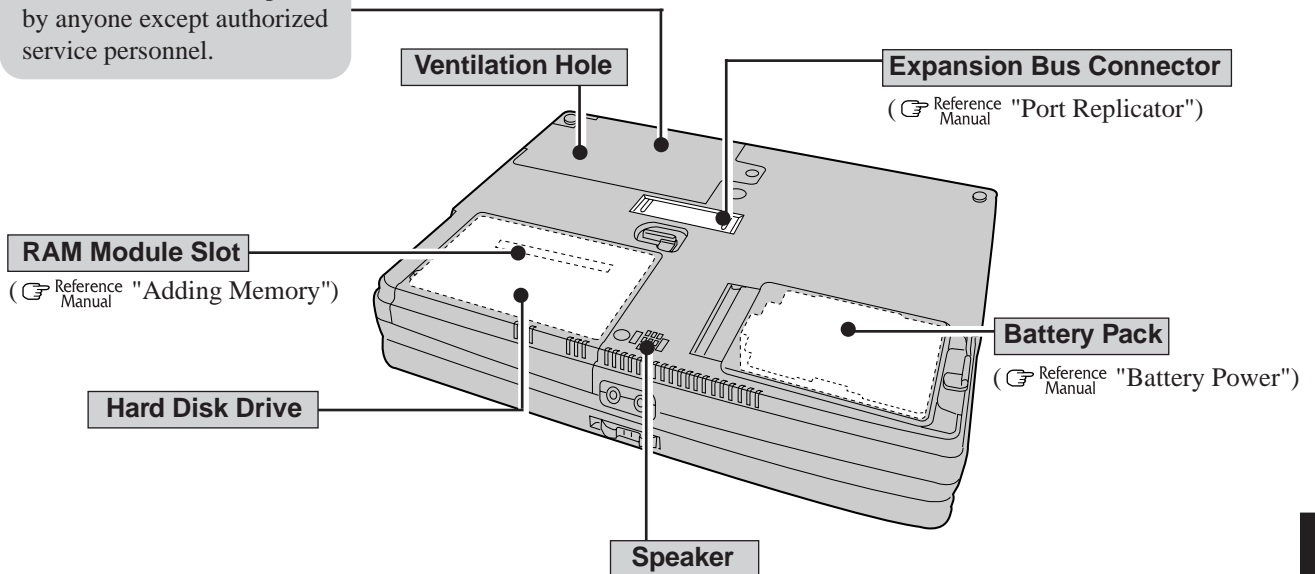
CAUTION
This cover is not to be opened by anyone except authorized service personnel.



● To adjust the volume*, select the  on the task bar, then [Volume Control].

* You may also use the function keys to perform this operation (Fn) + (F5) or (F6).

● Speaker on/off : (Fn) + (F4)

Specifications

● Main Specifications

Model No.		CF-45MJF8AAM	CF-45NJ48AAM/CF-45NJ48JAM/CF-45NJ48JCM
CPU		Pentium® Processor with MMX™ technology	
		200 MHz	233 MHz
Cache Memory (second cache memory)		32 KB (256 KB)	
EDO Memory (Expandable to)		32MB (96 MB Max.)	
Video Memory		2 MB	
LCD	Type	12.1" (TFT)	
	Displayed Colors*	256/65536/262144 colors (640 x 480 dots/800 x 600 dots)	
Hard Disk Drive (including about 200 MB used specifically by the system)		2 GB**	4 GB**

* 800 x 600 16-color resolution is not supported. If this resolution is selected, the message "There is an error in the display settings" will appear when you reboot. Start up again, selecting 256 Colors, High Color (16 bits), or True Color (24 bits), following the instructions on the screen.

Besides this phenomenon, you might encounter some unexpected behavior. Do not select 16 color mode in any resolution.

** 1GB = 10⁹ bytes

● Other Specifications

Keyboard	Windows 95 keyboard (for U.S.A.: 87 keys)			
Floppy Disk Drive	720 KB/1.44 MB (two-mode)			
CD-ROM Drive	20X speed (MAX)			
Slots	PC Card Slots	Two Type I or Type II, or one Type III		
		Allowable current (total for two slots)	3.3 V: 400 mA, 5 V: 400 mA, 12 V: 120 mA	
	RAM Module Slot	144-pin, 3.3-V, SO-DIMM  page 25		
Interface	Parallel Port	Dsub 25-pin female		
	Ext. Display Port	Mini Dsub 15-pin female		
	Serial Port	Dsub 9-pin male		
	Microphone Jack	Miniature jack, 3.5 DIA Input impedance 600 Ω, Input voltage range 0.01 Vp-p		
	Headphone Jack	Miniature jack, 3.5 DIA Impedance 32 Ω, Output Power 4 mW (Impedance 32 Ω) x 2		
	Infrared Communication Port	IrDA 1.1 compliant, 4 Mbps data transmission speed*		
	Ext. Keyboard/Mouse Port	Mini DIN 6-pin female		
	Expansion Bus Connector	Dedicated 100-pin female		
USB Connector	4-pin			
Pointing Device	Optical Trackball (Φ19)			
Speaker	Mono Speaker (built in)			
Sound	16 bits, 44.1 kHz PCM/FM sound (Sound Blaster PRO Compatible)			
Battery	Battery Pack	Lithium Ion 10.8 V, 2300 mAh		
	Operating Time	Approx. 1.0 - 2.5 hours**		
	Charging Time	Power On	Approx. 3.5 hours**	
		Power Off	Approx. 2.0 hours**	
Clock Battery	Coin type lithium battery 3.0 V			
	Operating Time	Approx. 10 years		
AC Adapter***	Input	100 -240 V AC, 50 / 60 Hz	Output 15.6 V DC, 3.2 / 3.85A	
Power Consumption	Approx. 55 W**** (maximum when recharging in the ON state)			
Physical Dimensions (W x H x D)	297 mm X 50.7mm X 230 mm (11.7 " X1.9 " X 9.1 ")			
Weight	Approx. 2.9 kg (Approx. 6.4 lbs)			

* Separate communications software is necessary.

** Varies depending on the usage conditions.

*** The AC adapter is compatible with power sources up to 240 V AC adapter.

The unit for North America (identified by the suffix 'M' on the model number) is supplied with a 125 V AC compatible AC cord.

**** Approx. 1.5 W when the battery pack is fully charged (or not being charged) and the computer is OFF.

● Software

Operating System	Microsoft® Windows® 95 (FAT32 File System)
Utility Programs	Diagnostics program Setup Utility DMI Viewer PhoenixCard Manager™ for Windows® 95



As an ENERGY STAR® Partner, Panasonic has determined that this product meets the ENERGY STAR® guidelines for energy efficiency.

Outline of the International ENERGY STAR® Office Equipment Program

The international ENERGY STAR® Office Equipment Program is an international program that promotes energy saving through the use of computers and other office equipment. The program backs the development and dissemination of products with functions that effectively reduce energy consumption. It is an open system in which business proprietors can participate voluntarily. The targeted products are office equipment such as computers, displays, printers, facsimiles, and copiers. Their standards and logos are uniform among participating nations.