

Panasonic

Digital Cordless Phone

Operating Instructions

Model No. **KX-TCD410AL**

Preparation

Cordless Telephone

Useful Information

Contents

Preparation

Before Initial Use	2
Important Information	3
Setting up	6

Cordless Telephone

Using the Telephone	11
Making Calls	12
Caller ID	13
Answering Calls	16
Phonebook	17
Handset Settings	21
Base Unit Settings	27
Initial Settings	29
Multi-unit User Operation	31
Intercom	35

Useful Information

Before Requesting Help	36
Technical Information	38
Index	39



Caller ID Compatible

PLEASE READ BEFORE USE AND SAVE.

Charge the battery for about 7 hours before initial use.

Before Initial Use

Thank you for purchasing your new Panasonic digital cordless telephone.

Dear purchaser,

You have acquired a KX-TCD410AL, which is a product made in regard with the Digital Enhanced Cordless Telecommunications (DECT). DECT technology is characterized by high-security protection against interceptions as well as high-quality digital transmission. This telephone was designed for a wide range of applications. For example, this telephone can be used within a network of base units and handsets, constituting a telephone system which:

- operates up to 6 handsets at one base unit.
- allows an intercom between 2 handsets.
- allows the operation of a handset at up to 4 base units, expanding the communication radio area.

Caller ID Service, where available, is a telephone company service. After subscribing to Caller ID, this phone will display the caller's phone number.

Accessories (included)

- AC Adaptor
PQLV19AL

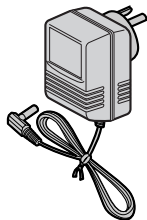

- Telephone Line Cord



- Rechargeable Batteries
(AAA size)
HHR-4EPT/BA2



- Telephone Plug

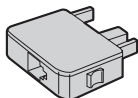

- Battery Cover

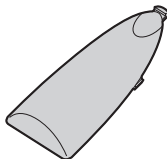

Additional accessories are available for purchase. Contact your Panasonic Service Centre for further details.

Important Information

Instructions to customer

Installation

Attached to this apparatus is an approval label. This label is evidence that it is a "Permitted Attachment" which has been authorised to be connected to your telephone service.

Conditions relating to connection and operation of this Permitted Attachment are contained in Telecommunications General By-Law 220 (5).

You are authorised to install this Permitted Attachment yourself by plugging it into the line socket of any regular telephone. You may connect it in place of your existing telephone or to any spare telephone socket installed in your premises.

To disconnect your existing telephone you must first remove its plug from the line socket. You can then insert the plug of your Permitted Attachment into the socket and use your equipment.

If the plug of your existing telephone cannot be readily removed, you will have to remove the screw securing it. To do this proceed as follows:

1. Loosen screw "A" sufficiently to remove the socket cover. (See Fig. 1.)
2. Remove screw "B" and withdraw the plug. (See Fig. 2.)
3. Replace screw "B". (See Fig. 3.) Ensure that it screws completely into the socket recess. (If the screw is too long, increase the hole depth or replace the screw with one 5 mm shorter.)
4. Replace socket cover and tighten screw "A". (See Fig. 4.)

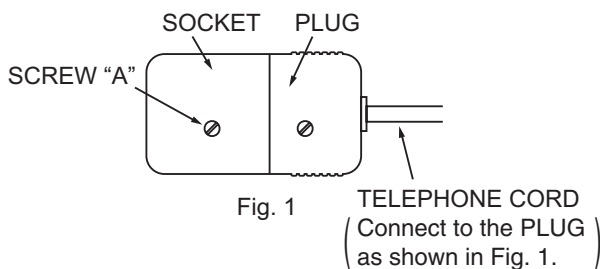

Fig. 1

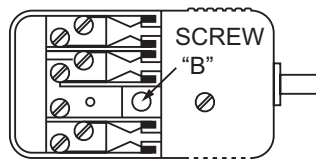

Fig. 2

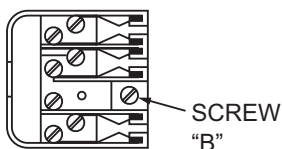

Fig. 3

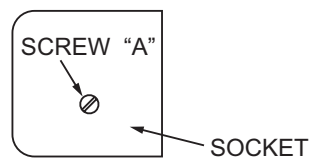

Fig. 4

Important Information

If you are satisfied with the operation of your telephone service after plugging in your Permitted Attachment, your installation is completed.

You will be unable to connect this Permitted Attachment if your telephone service consists only of a wall phone or an old style telephone which is not connected by means of a modern plug and socket. In such cases a new socket will need to be installed.

Should the Permitted Attachment not operate when plugged into a socket, it is either faulty or unsuitable for operation with your telephone service. It should be returned to the store where purchased or an Authorised Service Centre.

Service difficulties

If at any time a fault occurs on your telephone service, carry out the following checks before you call for service:

- Disconnect the Permitted Attachment and try using the service with the normal telephone.
- If the telephone service then operates satisfactorily, the fault is in your Permitted Attachment. Leave the Permitted Attachment disconnected and report the fault to its supplier or agent to arrange for repair.
- If when using the telephone the service is still faulty, report the fault to "Service Difficulties and Faults" for attention.

You are required to keep this Permitted Attachment in good working order while it is connected to your telephone service. Its construction or internal circuit must not be modified in any way without permission.

WARNING

This cordless telephone system does not incorporate provision for secrecy of conversations. Appropriately tuned radio equipment and other cordless telephone systems in close proximity may be used by a third party to monitor and possibly interrupt conversations in progress when this system is on radio operation.

Important Information

Only use the power supply included with the product.

Do not connect the AC Adaptor to any AC outlet other than the standard AC230 V.

The apparatus is approved for use with PQLV19AL power supply.

This apparatus is unable to make emergency telephone calls under the following conditions:

- The portable handset batteries need recharging, or have failed.
- During a mains power failure.
- When the Key Lock is set to ON.
- When the unit is in Direct Call mode.

Do not open the base unit or handset (other than to change the batteries).

This apparatus should not be used near emergency/intensive care medical equipment and should not be used by people with pacemakers.

Care should be taken that objects do not fall onto, and liquids are not spilled into the unit. Do not subject this unit to excessive smoke, dust, mechanical vibration or shock.

Environment

Do not use this unit near liquid—for example, near a bath tub, washbowl, sink, etc. Damp basements should also be avoided.

The unit should be kept away from heat sources such as heaters, kitchen stoves, etc. It also should not be placed in rooms where the temperature is less than 5 °C or greater than 40 °C.

The AC Adaptor is used as the main disconnect device, ensure that the AC outlet is located/installed near the unit and is accessible.

WARNING:

TO PREVENT THE RISK OF FIRE OR ELECTRICAL SHOCK, DO NOT EXPOSE THIS PRODUCT TO RAIN OR ANY TYPE OF MOISTURE. THE CORDLESS HANDSET IS MAGNETISED AND MAY RETAIN SMALL METALLIC OBJECTS.

Battery Caution

Use only specified batteries.

Only use rechargeable batteries.

Do not mix old and new batteries.

Do not dispose of batteries in a fire, they may explode.

Check local waste management codes for special disposal instructions.

Do not open or mutilate the batteries.

Released electrolyte is corrosive and may cause burns or injury to the eyes or skin.

The electrolyte may be toxic if swallowed.

Exercise care in handling the batteries in order not to short the batteries with conductive materials such as rings, bracelets and keys.

The batteries and/or conductor may overheat and cause burns.

Charge the batteries provided in accordance with the information given in this operating guide.

Location

- For maximum distance noise-free operation, place your base unit:
 - Away from electrical appliances such as TV, radio, personal computer or another phone.
 - In a convenient high and central location.

Setting up

◆◆ Connection

Plug in the AC adaptor and the telephone line cord in order 1, 2, 3, 4.

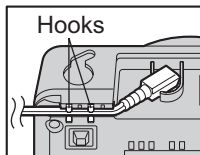

Fasten the AC adaptor cord to prevent it from being disconnected.

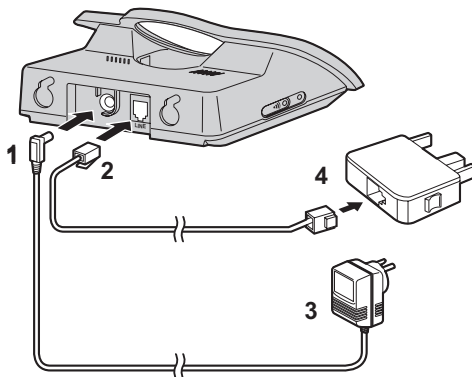

The AC adaptor must remain connected at all times. (It is normal for the adaptor to feel warm during use.)

- Never install telephone wiring during a lightning storm.
- KX-TCD410AL is not designed to be used with rotary (pulse dialling) services.

◆◆ Battery Installation

Please ensure the batteries are inserted as shown. ⊖ part should be inserted first. Close the cover as indicated by the arrow.

- When you replace the batteries, ⊕ part should be removed first.

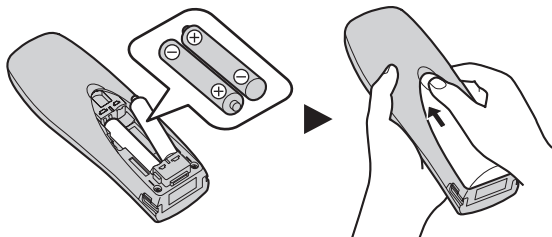

To replace the battery:

Press the notch on the cover firmly and slide it as indicated by the arrow. Replace 2 batteries and close the cover then charge the handset for about 7 hours.



◆◆ Battery Charge

At the time of shipment, the batteries are not charged. To charge, place the handset on the base unit. **Please charge the batteries for about 7 hours before initial use.** During charging, the battery icon is as shown below.

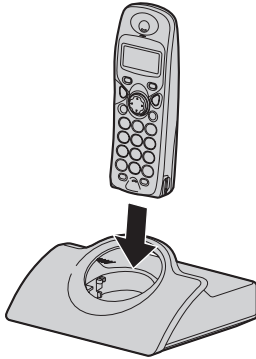

Fully charged **During charging**

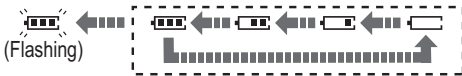

Display icon	Battery strength
	High
	Medium
	Low
	Needs to be charged

The handset which power is off will be turned on automatically when it is placed on the base unit.

In normal use, the handset and the base unit should be powered on at all times.

◆◆ Battery Life

Battery life is dependent on use and conditions but in general when using fully charged Ni-MH batteries (700 mAh):

Talk time: 10hrs approx.

Standby time: 120hrs approx.

When using Ni-Cd batteries (250 mAh):

Talk time: 4hrs approx.

Standby time: 40hrs approx.

(Times indicated are for peak performance.)





The batteries reach peak performance after several full charge/discharge cycles. The batteries cannot be overcharged unless they are repeatedly removed and replaced.

If battery life is shortened then please check that battery and charge terminals are clean.

For maximum battery life, it is recommended that the handset not be recharged until battery icon flashes .

Setting up

◆◆ Symbols Used in This Operating Instructions

Symbol	Meaning
	To search the desired item, press UP or DOWN .
	To select the desired item, press RIGHT .
	To search and then to select the desired item, press UP or DOWN then RIGHT .
	To move the cursor to the right or to the left, press RIGHT or LEFT .
	To go to the next step.
" "	The words in " " indicate the words in display.





◆◆ Replacing the Batteries



If the  icon flashes after a few telephone calls even when the handset batteries have been fully charged, 2 batteries must be replaced.

Charge new batteries for approximately 7 hours before initial use.

When replacing the batteries, ensure that the correct battery type is selected.

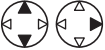
Selecting the Battery Type

1  Press MENU .	2  Search/Select "SETTING HS".	3  Search/Select "OTHER OPT".	4  Search/Select "BATTERY TYPE".
5  Search/Select "NI - CD" or "NI - MH".			

- To exit the operation, press  any time.
- When Ni-Cd batteries are fitted with the "BATTERY TYPE" setting in "NI-MH",  icon will disappear and stop charging even if the handset is on the cradle.
- Do not use non-rechargeable batteries. If non-rechargeable batteries are fitted and start charging, it may cause the leakage of the battery electrolyte.

Please use only Panasonic HHR-4EPT(Ni-MH) or P-4NPT(Ni-Cd) batteries.

◆◆ Location of Controls

Handset

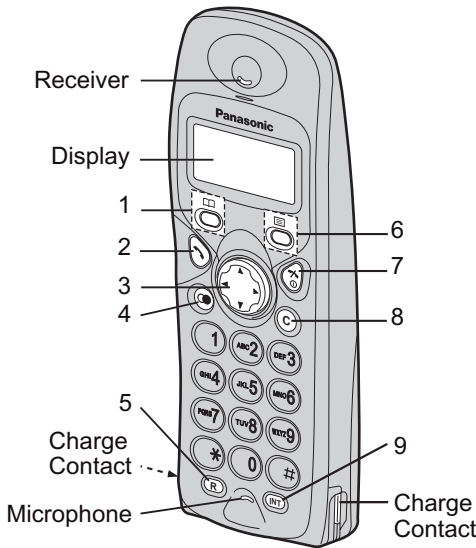

- 1 - **PHONEBOOK** Button
- 2 - **TALK** Button
- 3 - **Navigator** Key
- 4 - **REDIAL/PAUSE** Button
- 5 - **RECALL** Button
- 6 - **MENU/OK** Button
- 7 - **OFF/POWER** Button
- 8 - **CLEAR** Button
- 9 - **INTERCOM** Button

Base unit

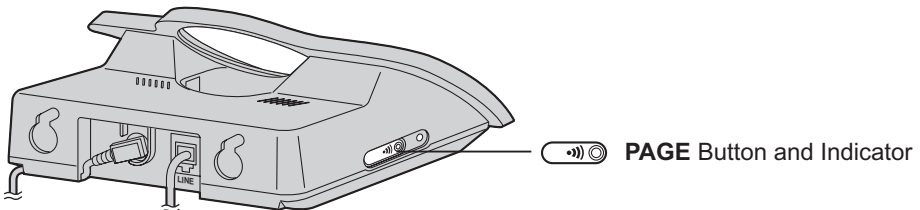

◆◆ Handset Display

- Within range of a base unit
- Out of range/No registration/
No power on base unit
- Paging or using the handset
- Making or answering calls
- Phonebook Mode
- In Setting Mode
- Battery strength is low.
- Battery strength is high.
- Call BAR ON** (p. 24)
- Direct Call ON** (p. 25)
- Key Lock ON** (p. 26)
- Ringer Volume OFF** (p. 22)
- Dialling Pause** (p. 26)

Setting up

◆◆ Wall Mounting

This unit can be mounted on a wall.

- Insert screws into the wall. The centre of the screw hole should be 8 cm horizontally apart.
- Connect the AC adaptor and the telephone line cord.
- Arrange the wires as shown, then mount the unit.

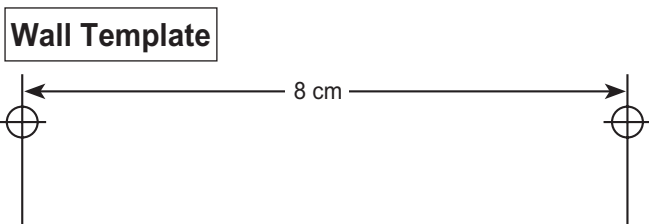
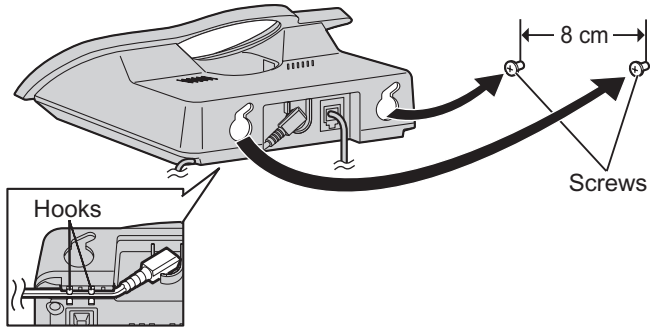

Using the Telephone

◆◆ Power On/Off

Power on



Press for more than 1 second.*1

Power off



Press for more than 2 seconds.*2

*1 When  button is released, the display changes to the standby mode.

*2 The display goes blank.

◆◆ Making a Call

Pre-dialling

1 Phone Number*1

2



Press TALK.

Post-dialling

1



Press TALK.

2 Phone Number

*1 If you need correction, press **CLEAR**. Digit is cleared to the left, then enter numbers.

◆◆ Answering a Call



Press TALK.*1

Terminating a Call

(During a call) →



Press OFF.

*1 You can also answer a call by pressing any dialling button, **INTERCOM**, **#** or *****.

◆◆ Setting the Clock/Date

After a mains power failure the clock needs to be reset. Ensure that  icon is not flashing.

1



Press **MENU**.

2



Search/Select
"SETTING BS".

→ "INPUT CODE"

3



Time
Enter time.
4-digit
(24 hour clock)*1

4



Press **OK**.

5



Press
RIGHT.

→ "INPUT CODE"

6



twice → Date
Enter day,
month then
year.*2

7



Press **OK**.

• To exit the operation, press  any time.

*1 For example, to set 7:15, enter 0715.

*2 For example, to set the 16th of February, 2003, enter 160203.

Making Calls

◆◆ Redialling







The last 10 numbers dialled are stored in the redial list automatically.

Dialling with the Redial List





Dialling the Last Number Dialled

1  Press REDIAL .*1	2  Search the desired dialled item.	3  Press TALK .	1  Press TALK .	2  Press REDIAL .
---	--	---	---	---

Editing the Dialled Number in the Redial List

1  Press REDIAL .*1	2  Search/Select the desired dialled item.	3  Search/Select "EDIT CALL NO".	The 1st digit of the desired dialled number blinks.
4  Move cursor.	5  Press CLEAR .*2	AND/OR Edit the phone number.*3	
6  Press TALK . OR  Press OK 3 times to store the number.			If you need to store a name, go to Name on page 17 or press OK .

Clearing One/All Dialled Item(s) in the Redial List

1  Press REDIAL .*1	2  Search/Select the desired dialled item.	3  Search/Select "CLEAR" or "ALL CLEAR".	4  Search/Select "YES".
---	---	---	--

- To exit the operation, press  any time.

*1 If there is no item stored in the redial list, the display shows "NO ITEM".

*2 Digits are cleared to the left of the flashing digit.

*3 Digits are added to the left of the flashing digit. If you need to clear and/or add more than one number, repeat from step 4.

◆◆ Caller ID Service

Caller ID is a service of your Network provider and will only operate if you have subscribed to this feature.

After subscribing to Caller ID, this phone will display the caller information.

If your unit is connected to a PBX or a telephone line that does not support this service, you will not be able to use it.

Caller ID does not display caller information while using the handset for an intercom call. However, the caller information will be stored to the Caller ID List.

Call Waiting and Caller ID Compatible: If you subscribe to Caller ID service, your handset displays the second caller's information while talking. After you hear a call-waiting tone, the caller's phone number will be displayed.

You can answer the second call, keeping the first call on hold. Follow Telstra or your service provider instructions using **RECALL**.

- If the phone number is stored in the phonebook with its name, the caller's name will also be displayed.
- Please contact Telstra or your service provider for details and availability in your area.

Using Caller ID Type II

When you receive a second call during a conversation, you will hear a signal tone following the call waiting tone and the **conversation will be interrupted or muted for a short period of time**. This is not the fault of the product as these events are normal.

Note: The tones are generated by the telephone company.

Caller ID

◆◆ Caller ID Service

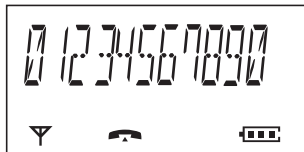

When receiving a call, the display shows its phone number.

For example, a caller whose phone number is 01234567890 has been received.

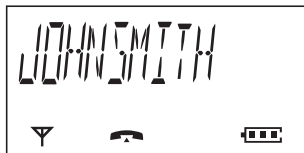

If you store a phone number with a name in the phonebook, the display shows caller's name when receiving a call.



If the caller has requested not to display his/her information, the display shows "PRIVATE".

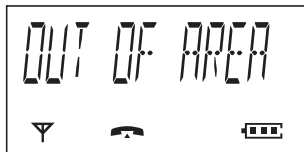

If the caller dialed from an area which does not provide Caller ID service, the display shows "OUT OF AREA".

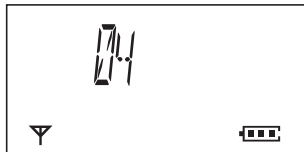

When new calls have been received, the display shows the numbers of calls.

For example, 4 new calls have been received.









◆◆ Caller ID List

Information up to 50 different callers is stored from the most recent call to the oldest call in the caller list. When the 51st call is received, the oldest caller information is cleared. If you receive a call from the same phone number you stored with a name in the phonebook, the display will show the caller's name.







Calling Back

1  Search the desired received item.*1	2  Press TALK .
---	---

Editing the Received Number in the Caller List

1   Search/Select the desired received item.*1	2   Search/Select "EDIT CALL NO".	3  Move cursor.
4  AND/OR Press CLEAR .*2	Number 5  Edit the number.*3	Press TALK . OR  Press OK 3 times to store the number.
		The 1st digit of the desired received number blinks.
		If you need to store a name, go to Name on page 17 or press OK .

Clearing One/All Received Item(s) in the Caller List

1   Search/Select the desired received item.*1	2   Search/Select "CLEAR" or "ALL CLEAR".	3   Search/Select "YES".
--	---	--

- To exit the operation, press  any time.

*1 If there is no item stored in the caller list, the display shows "NO ITEM".  on the right edge of the display when searching the item in the caller list indicates that the item has been already shown previously.





*2 Digits are cleared to the left of the flashing digit.

*3 Digits are added to the left of the flashing digit. If you need to clear and/or add more than one number, repeat from step 3.

Answering Calls

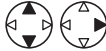
◆◆ Auto Talk

If you set Auto Talk to on, you can answer the phone by lifting the handset off the base unit.

1 	2 	3 	4 	5 
Press MENU .	Search/Select "SETTING HS".	Search/Select "OTHER OPT".	Search/Select "AUTO TALK".	Search/Select "ON" or "OFF".

- To exit the operation, press  any time.

◆◆ Temporary Bell Off

When an external call is incoming, you can temporarily turn off the handset ringer. This function will not work when the handset is on the base unit or if an internal call is incoming.

	
Press and hold DOWN for over 1 second.	



◆◆ Receiver Volume

During a call, press **UP** or **DOWN** to change the volume setting to LOW (0), MEDIUM (00), HIGH (000).

(During a call) 	
Press UP or DOWN .	

◆◆ Handset Locator/Paging





Using this feature, you can locate a misplaced handset by paging.

1 Press  on the base unit.	2 All registered handsets ring for 1 minute.
<To stop paging>	
3 Press  on the base unit	OR  *1 on one of the handsets.

*1 You can also stop paging by pressing any dialling buttons, **INTERCOM**, **#** or *****.

You can store up to 20 caller information in the phonebook. If you received a call from the same phone number you stored with a name in the phonebook, the display will show the caller's name.

◆◆ Storing a Caller Information











1  Press MENU .	2  Select "NEW PHONE".	3 Phone Number Enter phone number. (max. 24 digits)*1	4  Press OK .
5 Name Enter name. (max. 9 characters)*1	6  Press OK .*2		

• To exit the operation, press  any time.











































*1 If you need to make a correction, press **RIGHT** or **LEFT** to move cursor then clear digit/character by pressing **CLEAR**, and/or enter digits/characters. Digits/characters are cleared or added to the left of the flashing digit/character. To enter digits/characters, see Character Selection below.

*2 To continue storing another caller information, repeat from step 3.

Character Selection

Keys	Number of times key is pressed								Keys	Number of times key is pressed				
	1	2	3	4	5	6	7	8		1	2	3	4	5
	#	[]	*	'	-	/	1		M	N	O	6	
	A	B	C	2						P	Q	R	S	7
	D	E	F	3						T	U	V	8	
	G	H	I	4						W	X	Y	Z	9
	J	K	L	5						Blank	0			









Character Table

A	B	C	D	E	F	G	H	I	J	K	L	M	N	O	P	Q	R	S	T	U	V	W	X	Y
																								
Z	1	2	3	4	5	6	7	8	9	*	0	#	-	/	[]	,							
																								





Cordless Telephone

Phonebook

Editing a Caller Information

1 	2 	3 	➔ The 1st digit of the desired phone number blinks.
Press PHONEBOOK . ^{*1}	Search/Select desired item.	Select "EDIT".	
<Phone Number>			
4 	5 	AND/OR	Number
Move cursor.	Press CLEAR . ^{*2}		Edit the phone number. ^{*3}
<Name>			
7 	8 	AND/OR	Name
Move cursor.	Press CLEAR . ^{*2}		Edit the name. ^{*4}
			9 
			Press OK .

Clearing a Caller Information

1 	2 	3 	4 
Press PHONEBOOK . ^{*1}	Search/Select desired item.	Search/Select "CLEAR".	Search/Select "YES". ^{*5}

Dialling with the Phonebook

1 	2 	3 
Press PHONEBOOK . ^{*1}	Search desired item.	Press TALK .

- To exit the operation, press  any time.

*1 If there is no item stored in the phonebook, the display shows "NO ITEM".



*2 Digits are cleared to the left of the flashing digit.

*3 Digits are added to the left of the flashing digit. If you need to clear or add more than one digit, repeat from step 4.

*4 Characters are added to the left of the flashing character. If you need to clear or add more than one character, repeat from step 7.

*5 To continue clearing another caller information, repeat from step 2.

◆◆ Storing the Phone Number into the Phonebook When Pre-dialling





1 Phone Number*1	2  Press OK to store the number.	3  Press OK twice.	4 Name Enter name.*2
5  Press OK .			

• To exit the operation, press  any time.

*1 If you need correction, press **CLEAR**. Digit is cleared to the left, then enter numbers.

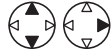
*2 To enter characters, see Character Selection on page 17.

◆◆ Storing the Number from the Redial/Caller List into the Phonebook

1	 Press REDIAL .*1 OR  Search/Select the desired received number.*1	 Search/Select the desired dialled number.	2	 Search/Select "SAVE TEL NO".*2	3	 Press OK .
4	If you need to store a name, go to Name on page 17. OR  Press OK .					

• To exit the operation, press  any time.

*1 If there is no item stored in the redial/caller list, the display shows "NO ITEM".

*2 If you need to make a correction, press **RIGHT** or **LEFT** to move cursor then clear a digit by pressing **CLEAR**, and/or enter digits. Digits are cleared or added to the left of the flashing digit.





Cordless Telephone

Phonebook

◆◆ Hot Key

You can assign the dialling buttons 1 through 9 as hot keys. You can choose 9 phone numbers from the phonebook.

Registering a Phone Number as a Hot Key

1  Press PHONEBOOK . ^{*1}	2  Search/Select desired item.	3  Search/Select "HOT KEY REG".	4  Search/Select desired dialling button number. ^{*2}
5  Search/Select "YES".			

Dialling with Hot Key

1 Press and hold the dialling button registered as a hot key.	2  Press TALK .
--	---

Clearing the Hot Key Registration

1 Press and hold the dialling button registered as a hot key.	2  Press RIGHT .	3  Select "CLEAR".	4  Search/Select "YES". ^{*3}
--	--	---	---

- To exit the operation, press  any time.

*1 If there is no item stored in the phonebook, the display shows "NO ITEM".

*2 The number is flashing if the dialling button is already assigned as a hot key.

*3 Phonebook registration will be remained even hot key registration is cleared.



TIME ALARM : Time Alarm

Before programming, please follow steps 1 to 3.



You must set the clock before setting the time alarm.

- 1  Press **MENU**.
- 2  Search/Select
"SETTING HS".
- 3  Search/Select
"TIME ALARM".

Setting Alarm Time

- 4  Search/Select
"SET TIME".
- 5 **Time**
Enter time.
4-digit
(24 hour clock)
- 6  Press **OK**.
- 7  Search/Select
"OFF",
"ONCE" or
"REPEAT DAILY".

Setting Time Alarm On/Off

- 4  Search/Select
"SET ALARM".
- 5  Search/Select
"OFF",
"ONCE" or
"REPEAT DAILY".

- To exit the operation, press  any time.

To stop time alarm: Time alarm will sound for 3 minutes. When the alarm sounds, press any dialling buttons or key. Alarm stops and display returns to the standby mode. If "ONCE" is selected, the setting is turned off. When in talk or intercom mode, the alarm will not sound until the call is ended.

Handset Settings

: Ringer Option

Before programming, please follow steps 1 to 3.

- 1**  Press **MENU**.
- 2**   Search/Select
"SETTING HS".
- 3**   Search/Select
"RINGER OPT".

Setting the Ringer Volume





The choices are 6 levels and off.

- 4**   Search/Select
"RINGER VOL".
- 5**   Search/Select
desired ringer volume.

- If "RINGER OFF" is selected, .... is displayed.

Setting the Ringer Pattern for External Call/Internal Call/Paging/Alarm

There are 20 patterns available on each ringer.

- 4**   Search/Select
"EXT RINGER",
"INT RINGER",
"PAGING" or
"ALARM".
- 5**   Search/Select
desired ringer pattern.*1

- To exit the operation, press  any time.
- *1 If you select one of the melody ringer patterns, it keeps ringing for 10 seconds even if a caller hangs up a call. Therefore, you may hear dial tone or no one there after you answer a call.

◆◆ TONE OPT : Tone Option





You can set the following sounds on or off.

Key Tone: Key tone will sound when you press any key, and a confirmation tone and an error tone will be heard during operation.

Call Waiting Tone: Call waiting tone will sound when an incoming external call is received during an intercom call.

Range Warning Alarm: Alarm will sound when you move out of range of a base unit.





Battery Low Alarm: Alarm will sound when the batteries need to be charged.

1  Press MENU .	2  Search/Select "SETTING HS".	3  Search/Select "TONE OPT".	4  Search/Select "KEY TONE", "CALL WAITING", "RANGE ALARM" or "BATTERY LOW".
5  Search/Select "ON" or "OFF".			

- To exit the operation, press  any time.

◆◆ DISPLAY OPT : Display Option

Selecting the Standby Mode Display

1  Press MENU .	2  Search/Select "SETTING HS".	3  Search/Select "DISPLAY OPT".	4  Search/Select "STANDBY MODE".
5  Search/Select "CLOCK",*1 "OFF", "BS NO"(Base unit number) or "HS NO"(Handset number).			

- To exit the operation, press  any time.

*1 Time will only be displayed if the clock has been set. When new calls have been received, the display shows the number of new call.



Handset Settings

Before programming, please follow steps 1 to 3.

- 1  Press **MENU**.
- 2  Search/Select "SETTING HS".
- 3  Search/Select "DISPLAY OPT".

Selecting the Talk Mode Display

Even if you select "PHONE NO", the other party's phone number will not appear on your display when you receive calls without subscribing to a Caller ID service.

- 4  Search/Select "TALK MODE".
- 5  Search/Select "TALK TIME"(Length of the call) or "PHONE NO"(Phone number).

Selecting the Display Language

- 4  Search/Select "LANGUAGE".
- 5  Search/Select desired language.*1

- To exit the operation, press  any time.
- If "F43 00" is selected, the Command Interface will be displayed instead of a language. Each menu will be displayed as an alphanumeric code. The Command Interface codes for each menu item are shown on page 4 of the Quick Guide.





*1 You can select one of 10 languages. If you set a language you cannot read, reset the handset to its initial settings.

Press **MENU** \blacktriangleright **DOWN** \blacktriangleright **RIGHT** \blacktriangleright **UP** \blacktriangleright **RIGHT** \blacktriangleright **4-digit Handset PIN** \blacktriangleright **UP** \blacktriangleright **OK**.
All handset setting will be reset to their initial settings (p. 29), however, the Phonebook data will be saved.

: Call Option

Call BAR On/Off

This allows you to make an emergency and internal call.

- 1  Press **MENU**.
- 2  Search/Select "SETTING HS".
- 3  Search/Select "CALL OPT".
- 4  Search/Select "CALL BAR".
- 5 **4-digit Handset PIN***1
- 6  Search/Select "ON" or "OFF".*2

- To exit the operation, press  any time.

*1 The factory preset is 0000.

*2 If "ON" is selected,  is displayed.



Handset Settings

Before programming, please follow steps 1 to 3.



-  Press **MENU**.
-  Search/Select
"SETTING HS".
-  Search/Select
"CALL OPT".

Setting the Direct Call Number

After a direct call number has been set and on, you can dial the direct call number only by pressing **TALK**. Incoming calls are accepted.

-  Search/Select
"DIRECT NO".
- 5 Phone Number**
Enter the direct call number. (max. 24 digits)
-  Press **OK** 3 times.*1

Setting the Direct Call On/Off

-  Search/Select
"SET DIRECT".
-  Search/Select
"ON" or "OFF".*1





- To exit the operation, press  any time.

*1 If "ON" is selected,  is displayed.

OTHER OPT : Other Options

Changing Handset PIN

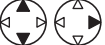
The factory preset is 0000. Once you have programmed the handset PIN, you cannot confirm it. We recommend you write down the handset PIN. If you forget it, please consult your nearest Panasonic Service Centre.

-  Press **MENU**.
-  Search/Select
"SETTING HS".
-  Search/Select
"OTHER OPT".
-  Search/Select
"HSPIN CHANGE".
- 5 Current 4-digit Handset PIN**
- 6 New 4-digit Handset PIN**
- 7 New 4-digit Handset PIN again to verify**

- To exit the operation, press  any time.

Handset Settings

◆◆ Key Lock

You can lock the handset dialling buttons. Only incoming calls are accepted while the key lock is on. The key lock is cancelled if the handset is turned off.

When the key lock is on, emergency calls cannot be made until key lock is cancelled.

Key Lock On



Press **OK** for more than 2 seconds.

Key Lock Off



Press **OK** for more than 2 seconds.

-  is displayed and all dialling buttons are locked.

◆◆ Recall Feature

RECALL is used to access special telephone services. Contact your Network provider for details. If your unit is connected to a PBX, pressing **RECALL** allows you to access some features of your host PBX such as transferring an extension call.

- Users in Australia can access Telstra's "EASY CALL" service by having the recall time set at 100 msec (this is the factory default setting), and then follow Telstra's "EASY CALL" instructions to operate this service.

◆◆ Dialling Pause (for PBX line/long distance service users)

A dialling pause is used when a pause in the dialling of the phone number is necessary using a PBX or accessing a long distance service.

For example, when 0 (line access number) is dialled followed by a pause to access an outside line through a PBX:

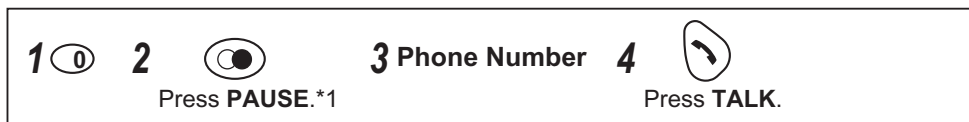

- Entering a pause prevents misdialling when you redial or dial a stored number.
- Pressing **PAUSE** once creates one pause. To extend the pause requirement time, press **PAUSE** accordingly.

*1  is displayed on the LCD.

Base Unit Settings

Before programming, please follow steps 1 to 2.

- 1**  Press **MENU**.
- 2**  Search/Select
"SETTING BS".
- ➔ "INPUT CODE"





Changing Base Unit PIN

The factory preset is 0000. **Once you have programmed the base unit PIN, you cannot confirm it. We recommend you write down the base unit PIN. If you forget it, please consult your nearest Panasonic Service Centre.**



- 3**  **4** Current 4-digit Base Unit PIN **5** New 4-digit Base Unit PIN
- 6** New 4-digit Base Unit PIN again to verify

Call Restriction

You can restrict selected handset(s) from dialling selected phone numbers. You can assign up to 10 call restriction numbers (up to 8 digits). If you dial a restricted number, the call does not connect and restricted number flashes.

- 3**  **4** 4-digit Base Unit PIN*1
- 5** Handset Number
Select desired handset number.*2
- 6**  Press **RIGHT**.
- 7** Phone Number
Enter phone number to be restricted.
(up to 8 digits)
- 8**  Press **RIGHT**.
- 9**  Press **OFF**.
OR
To continue entering call restriction numbers, repeat the steps 7 to 8.
(up to 10 numbers)

Cancelling Call Restricted Handset(s)

- 3**  **4** 4-digit Base Unit PIN*1
- 5** Handset Number
Select desired handset number.*3
- 6**  Press **RIGHT**.
- 7**  Press **OFF**.

- To exit the operation, press  any time.

*1 The factory preset is 0000.

*2 The selected handset number flashes.



*3 The selected handset(s) number(s) will stop flashing.

Base Unit Settings

Before programming, please follow steps 1 to 2.

- 1  Press **MENU**.
- 2  Search/Select
"SETTING BS".
- ➔ "INPUT CODE"

Cancelling Call Restricted Number

3  4 **4-digit Base Unit PIN*1** 5  Press **RIGHT** repeatedly until desired call restriction number is displayed.

6  Press **CLEAR**.







7  Press **RIGHT**.

8 **<to continue>** OR **<to finish>**
Repeat the steps 5 to 7.

 Press **OFF**.





Selecting the Recall Time

You can select the recall time, 700 msec (milliseconds), or 100 msec depending on your PBX requirements.

3  4 **4-digit Base Unit PIN*1** 5  6  7  700 msec OR  100 msec 8  Press **OK**.

Pause Timing

You can set the pause timing to 3 or 5 seconds, depending on your PBX requirements.

3  4 **4-digit Base Unit PIN*1** 5  6  3 Seconds OR  5 Seconds 7  Press **OK**.





- To exit the operation, press  any time.
- The factory preset is in shade.

*1 The factory preset is 0000.

Initial Settings

◆◆ RESET HS : Reset Handset Settings

You can reset all of the handset settings to their initial settings.

1  Press MENU .	2  Search/Select "SETTING HS".	3  Search/Select "RESET HS".	4 4-digit Handset PIN*1
5  Search/Select "YES" or "NO".			

- To exit the operation, press  any time.

*1 The factory preset is 0000.

Handset Initial Settings



Function	Initial Setting
Time Alarm Mode	OFF
Alarm Time	Clear
Handset Ringer Volume	6
Handset External Ringer Pattern	1
Handset Internal Ringer Pattern	1
Handset Paging Tone Pattern	1
Handset Alarm Tone Pattern	1
Key Tone	ON
Call Waiting Tone	ON
Range Warning Alarm	OFF
Battery Low Alarm	ON
Standby Mode Display	Clock
Talk Mode Display	Length of the Call
Display Language	English
Call BAR	OFF
Direct Call Mode	OFF
Direct Call Number	Clear
4-Digit Handset PIN	0000
Auto Talk	OFF
Base Unit Access	Automatic Base Unit Access
Redial Memory	All Clear
Handset Receiver Volume	Medium

Cordless Telephone

Initial Settings

◆◆ Reset Base Unit Settings

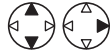
If the base unit is reset, the Caller ID list will clear.

1 	2 	3 
Press MENU .	Search/Select "SETTING BS".	"INPUT CODE"
4 4-digit Base Unit PIN*1	5 	
	Press OK .	

- To exit the operation, press  any time.
- *1 The factory preset is 0000.

Base Unit Initial Settings

Function	Initial Setting
Ringer Mode	All Handsets
Number of Rings	3
Recall Time	100 msec
Pause Timing	3 seconds
Call Restricted Handsets	All Clear
Call Restriction Numbers	All Clear
4-Digit Base Unit PIN	0000

Multi-unit User Operation









◆◆ REGISTRATION : Handset Registration to a Base Unit

Handset Registration

The handset supplied with the base unit is already registered. If an optional handset is purchased, it must be registered. Additional **KX-A142AL** handsets are available to purchase separately. Up to 6 handsets can be registered to a single base unit. Using additional handsets allows you to have an intercom call while simultaneously conducting a call to an outside line.

Handset must be registered within 1 minute after pressing **PAGE** button. If over 1 minute, press  then start over again.

Charge the optional handset batteries for 7 hours before initial use.

1  Press MENU .	2  Search/Select "SETTING HS".	3  Search/Select "REGISTRATION".	▶ "REGISTER HS"
4  Press RIGHT .	5 Press and hold  on the Base Unit (for about 10 seconds) until the green indicator flashes. • If all registered handsets start ringing (Paging), press  to stop paging then start over again.		
6  Search/Select desired base unit number available to register the handset.	7 4-digit Base Unit PIN after "BS PIN" is displayed.*1	8  Press OK .	▶ When a handset is registered successfully, a confirmation tone sounds and  icon lights.

• To exit the operation, press  any time.

*1 The factory preset is 0000.







KX-A142AL Handset: You can see the illustrations for answering system feature on additional KX-A142AL handset body, but KX-TCD410AL does not have an answering system feature. Therefore, the answering system does not work even if KX-A142AL handset has been registered to KX-TCD410AL.

Cordless Telephone

Multi-unit User Operation



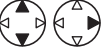

Cancelling a Base Unit

You can cancel any base unit that your handset is registered to.

1  Press MENU .	2  Search/Select "SETTING HS".	3  Search/Select "REGISTRATION".	4  Search/Select "CANCEL BS".
5 4-digit Handset PIN*1	6  Search/Select desired base unit number to cancel.*2	7  Press RIGHT .	8  Search/Select "YES" or "NO".

Cancelling a Handset

Each handset can cancel itself or another handset.

1  Press MENU .	2  → "INPUT CODE"	3 
4 4-digit Base Unit PIN*1	5 Handset Number Select desired handset number.*3	6  → Please wait until "SETTING BS" is displayed.

- To exit the operation, press  any time.



*1 The factory preset is 0000.

*2 The selected base unit number flashes.

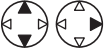

*3 The selected handset number flashes.

Multi-unit User Operation



Before programming, please follow steps 1 to 4.

- 1  Press MENU.
- 2  Search/Select "SETTING BS".
- 3  "INPUT CODE"
- 4  4-digit Base Unit PIN*1

Ringer Mode Selection; Setting the All Handsets Mode



- 5  All handsets mode.
- 6  Press OK.

Setting the Selected Handsets Mode

- 5  Selected handsets mode.
- 6 Handset Numbers*2 Press desired handset numbers.
- 7  Press OK.

Setting the Selected then All Handsets Mode



The specific handset(s) will ring for a selected number of rings.
If not answered, all handsets will ring.

- 5  Selected then all handsets mode.
- 6 Handset Numbers*2 Press desired handset numbers.
- 7  Press RIGHT.
- 8 Number of Rings*3 Select how many times it rings. (up to 6 rings)
- 9  Press OK.

- To exit the operation, press  any time.
- The factory preset is in shade.

*1 The factory preset is 0000.

*2 The selected handset number flashes.

*3 Press dialling button  through  to enter the number of rings.

Multi-unit User Operation

◆◆ SELECT BS : Base Unit Selection

When Automatic Base Unit Access is selected, if you move outside of the radio range of the current base unit the handset automatically searches for other registered bases. When a specified base unit is selected, the handset will access that base unit only. Calls (both incoming and outgoing) can be conducted only via the selected base unit, even if the radio cells overlap with neighbouring base units.

1 	2 	3 	4 
Press MENU .	Search/Select "SETTING HS".	Search/Select "SELECT BS".	Search/Select "AUTO" or specific base unit number.

- To exit the operation, press  any time.

Operating Additional Base Units: You can register and operate your handset with up to 4 base units. Each base unit forms 1 radio cell. If the individual bases are linked to the same telephone line then you can extend the operating range of the system by positioning the bases so that the two radio cells overlap. If the handset is set to AUTO base selection, then in standby mode the handset will automatically swap to the second base if the range on the first base is exceeded. It is not possible to transfer calls between bases (only between handsets linked to the same base unit).

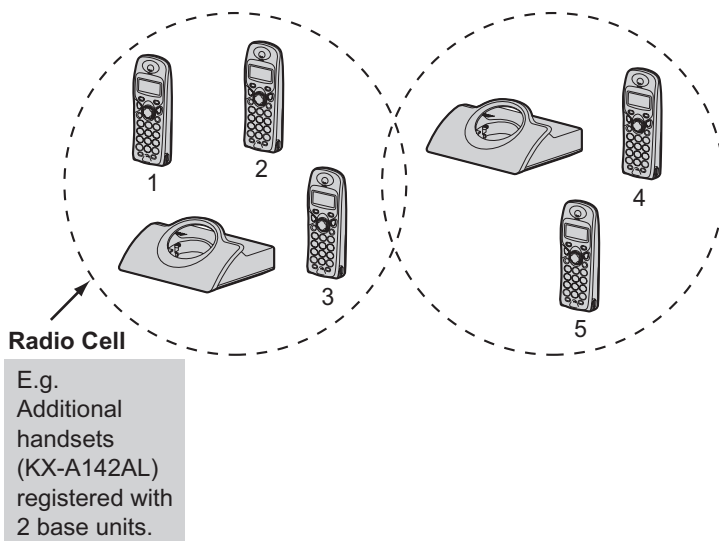

Note: Calls are disconnected when the handset moves from one radio cell to another.

Intercom between Handsets

You can use your handsets as a 2-way intercom.

For example, when Handset 1 calls Handset 2. To hang up, press .

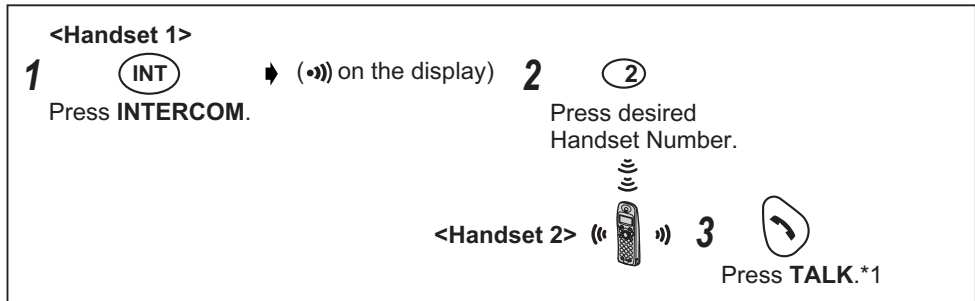

- Intercom calls can be conducted within the radio cell of the current base unit, but not with units in neighbouring radio areas.

Transferring a Call to Another Handset/Conference Call

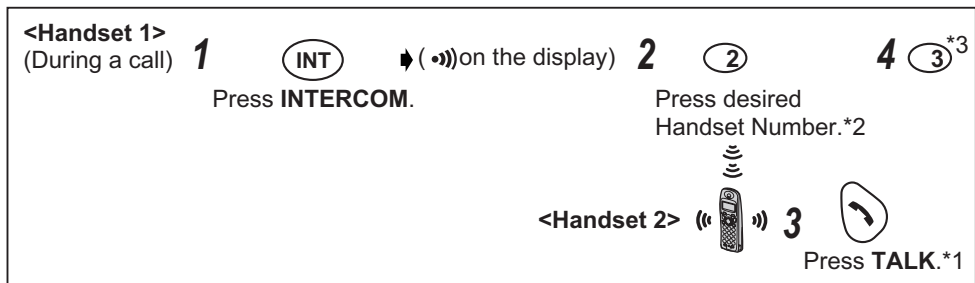

Intercom can be used during a call to transfer an external call between handsets that are registered to the same base unit. For example, when handset 1 transfers a call to Handset 2. To hang up, press .



^{*1} You can also press any dialling button, **INTERCOM**, **#** or *****.

^{*2} If you press  after pressing desired handset number, a call can be transferred to another handset without speaking to another handset.

If the transferred call is not answered within 30 seconds, Handset 1 will ring again.

^{*3} When Handset 2 answers a call transferred, press  to complete a call transfer or press dialling button  to establish the conference call.

Before Requesting Help

If you experience any problems with the normal use of your apparatus, you should unplug it from the telephone outlet and connect a known working telephone in its place. If the known working telephone still has problems, then please contact the customer service department of your Network provider.



If it operates correctly, then the problem is likely to be a fault in your apparatus.

In this case, contact your supplier for advice. Your Network provider may charge you if they attend a service call that is not due to apparatus supplied by them.

Turn the power OFF then ON (Handset)/Disconnect then connect the AC adaptor (Base unit).

Problem	Possible cause	Solution
NO LCD display in handset.	<ul style="list-style-type: none"> • Handset not turned on. 	<ul style="list-style-type: none"> • Turn on power (p. 11).
Handset will not turn on.	<ul style="list-style-type: none"> • Batteries not inserted. • Batteries not charged. 	<ul style="list-style-type: none"> • Insert the 2 rechargeable batteries supplied (p. 6). • Place handset in base and connect AC adaptor to base and AC outlet (full charge period 7 hrs).
Batteries charge icon not counting up.	<ul style="list-style-type: none"> • Dirty charge contact. • Base not powered up. 	<ul style="list-style-type: none"> • Clean charge/battery contact and retry charge. • Connect AC adaptor to base unit and AC outlet.
📶 icon flashes.	<ul style="list-style-type: none"> • Handset not registered to base. • Handset out of range of base. • No power into base unit. 	<ul style="list-style-type: none"> • Register handset to base. • Move handset closer to base. • Connect AC adaptor to base unit and AC outlet.
Handset busy tone heard when  is pressed.	<ul style="list-style-type: none"> • Handset out of range of base. • Another handset in use. 	<ul style="list-style-type: none"> • Move handset closer to base. • Wait for the other user to complete call.
No dial tone.	<ul style="list-style-type: none"> • Telephone line not connected. 	<ul style="list-style-type: none"> • Insert telephone cord to network. • Turn power OFF then ON.
Cannot dial out.	<ul style="list-style-type: none"> • Call BAR set. • Particular dialled number is restricted. • Key lock mode ON. 	<ul style="list-style-type: none"> • Turn feature off. • Remove number from call restricted list. • Turn key lock OFF.

Before Requesting Help

Problem	Possible cause	Solution
Handset will not ring.	<ul style="list-style-type: none"> • Ringer switched off. 	<ul style="list-style-type: none"> • Set ringer to one of 6 volume levels. (see “Handset Settings”.)
Last number redial does not work.	<ul style="list-style-type: none"> • Number exceeded 24 digits. 	<ul style="list-style-type: none"> • Redial manually.
No Caller ID number displayed.	<ul style="list-style-type: none"> • Service not supplied. • Caller has withheld info. 	<ul style="list-style-type: none"> • Caller ID service must be arranged with Network provider.
 icon flashes.	<ul style="list-style-type: none"> • Battery low. 	<ul style="list-style-type: none"> • Recharge batteries.
 icon is disappeared.	<ul style="list-style-type: none"> • Wrong battery type selected. 	<ul style="list-style-type: none"> • Set the correct battery type.
Cannot register handset to base.	<ul style="list-style-type: none"> • Max. number of bases already registered to handset. • Max. number of handsets already registered to base unit. • Wrong PIN number entered (Default 0000). • Electrical noise in local area. 	<ul style="list-style-type: none"> • Delete unused base registrations from handset. • Delete unused handset registrations from base. • If PIN number is lost, contact the Panasonic Service Centre. • Move base/handset away from sources of electrical noise (TVs, radios, etc.).

Panasonic Australia operates a toll free Customer Support Centre. Please phone Panasonic on 132600 for assistance.

Technical Information

Specifications:

Standard:	DECT=(<u>D</u> igital <u>E</u> nhanced <u>C</u> ordless <u>T</u> elecommunications) GAP=(<u>G</u> eneric <u>A</u> ccess <u>P</u> rofile)
Number of channels:	120 Duplex Channels
Frequency range:	1.88 GHz to 1.9 GHz
Duplex procedure:	TDMA (Time Division Multiple Access)
Channel spacing:	1728 kHz
Bit rate:	1152 kbit/s
Modulation:	GFSK
RF Transmission Power:	Approx. 250 mW
Voice coding:	ADPCM 32 kbit/s
Power source:	AC Adaptor 220 - 240 V, 50 Hz
Power consumption, base unit:	Standby: Approx. 3.5 W Maximum: Approx. 9.2 W
Operating conditions:	5 - 40 °C, 20 - 80 % relative air humidity (dry)
Dimensions, Base Unit:	About (58 mm x 128 mm x 105 mm) x 170 g
Dimensions, Handset:	About (143 mm x 48 mm x 32 mm) x 120 g

- Specifications are subject to change.
- The illustrations used in this manual may differ slightly from the original device.

Connections:

The unit will not work during a power failure. We recommend you connect a standard telephone on the same line for power protection.

AC Adaptor	2, 6	Handset	
Accessories	2	Display	9
Answering Calls	16	Initial Settings	29
Auto Talk	16	Locator	16
Base Unit		Paging	16
Initial Settings	30	PIN	25
PIN	27	Registration	31
Reset	30	Reset	29
Selection	34	Ringer	22
Battery		Intercom	35
Caution	5	Key	
Charge	7	Lock	26
Installation	6	Tone	23
Life	7	Making Calls	
Battery Low Alarm	23	Redialling	12
Call Restriction		with the Phonebook	18
Cancelling Call Restricted		Phonebook	
Handset(s)	27	Hot Key	20
Cancelling Call Restricted Number ...	28	Storing	17
Call Waiting	13	Power On/Off	11
Caller ID List		Range Warning Alarm	23
Calling Back	15	Recall	26
Clearing	15	Recall Time	28
Editing	15	Receiver Volume	16
Storing	19	Ringer Pattern	22
Calls		Ringer Volume	22
Answering	11	Setting up	6
Making	11, 12	Specifications	38
Redialling	12	Time Alarm	21
Terminating	11	Tone Option	23
Cancelling a Base Unit	32	Wall Mounting	10
Cancelling a Handset	32		
Clock/Date	11		
Conference Call	35		
Dialling Pause	26		
Direct Call Number	25		
Display			
Standby Mode	23		
Talk Mode	24		

For your future reference

Serial No.

Date of purchase

(found on the bottom of the unit)

Name and address of dealer

Attach or keep original receipt to assist with any repair under warranty.



Technical specifications are subject to change.

Panasonic Australia Pty. Limited
Austlink Corporate Park
1 Garigal Road
Belrose
NSW 2085
Australia

Panasonic Communications Co., Ltd.
1-62, 4-chome, Minoshima, Hakata-ku, Fukuoka 812-8531, Japan