

# Panasonic

## Operating Instructions and Cookbook

उपयोग के निर्देश और पाक-पुस्तक  
چلانے سے متعلق ہدایات اور پکوان کی کتاب  
دفترچہ راہنما و کتاب آشپزی  
تعلیمات التشغيل و کتاب الطبخ



## Microwave Oven

माइक्रोवेव ओवन

مائکرو ویو اوون

اجاق مائیکروویو

فرن مائیکروویف

**Models NN-SM330W**

**NN-ST340W**

**Panasonic Corporation**

Web Site: <http://panasonic.net>

F00039V20KP  
IP1110-0

Before operating this oven, please read these instructions completely and keep for future reference.

اس اوون کو چلانے سے پہلے، براہ کرم یہ ہدایات پوری طرح پڑھیں اور آئندہ کے حوالے کے لئے سنبھال کر رکھیں۔

قبل از راه اندازی این اجاق، لطفاً این دستورات را بطور کامل بخوانید و برای رجوع در آینده نگه دارید.

قبل تشغيل هذا الفرن، يرجى قراءة هذه التعليمات بالكامل والاحتفاظ بها كمرجع في المستقبل.

# Important Safety Instructions

## READ CAREFULLY AND KEEP FOR FUTURE REFERENCE

### Precautions to be taken when using Microwave Ovens for Heating Foodstuffs

#### Inspection for Damage:

A microwave oven should only be used if an inspection confirms all of the following conditions:

1. The door fits squarely and securely and opens and closes smoothly.
2. The door hinges are in good condition.
3. The metal plates of a metal seal on the door are neither buckled nor deformed.
4. The door seals are neither covered with food nor have large burn marks.

#### Precautions:

Microwave radiation from microwave ovens can cause harmful effects if the following precautions are not taken:

1. Never tamper with or deactivate the interlocking devices on the door.
2. Never poke an object, particularly a metal object, through a grille or between the door and the oven while the oven is operating.
3. Never place saucepans, unopened cans or other heavy metal objects in the oven.
4. Do not let other metallic articles, e.g. fast food foil containers, touch the side of the oven.
5. Clean the oven cavity, the door and the seals with water and a mild detergent at regular intervals. Never use any form of abrasive cleaner that may scratch or scour surfaces around the door.
6. Always use the oven with the trays or cookware recommended by the manufacturer.
7. Never operate the oven without a load (i.e. an absorbing material such as food or water) in the oven cavity unless specifically allowed in the manufacturer's literature.
8. For horizontally hinged doors, never rest heavy objects such as food containers on the door while it is open.
9. Do not place sealed containers in the microwave oven. Baby bottles fitted with a screw cap or a teat are considered to be sealed containers.
10. This appliance is not intended for use by persons (including children) with reduced physical, sensory or mental capabilities, or lack of experience and knowledge, unless they have been given supervision or instruction concerning use of the appliance by a person responsible for their safety.
11. Young children should be supervised to ensure that they do not play with the appliance.
12. It is hazardous for anyone other than a competent person to carry out any service or repair operation that involves the removal of a cover which gives protection against exposure to microwave energy.

#### Earthing Instructions

This microwave oven must be earthed. In the event of an electrical short circuit, earthing reduces the risk of electric shock by providing an escape wire for the electric current. This microwave oven is equipped with an earthing plug. The plug must be plugged into an outlet that is properly installed and earthed.

**WARNING**—Improper use of the earthing plug can result in electric shock.

#### Important Instructions

**WARNING**—To reduce the risk of burns, electric shock, fire, injury to persons or excessive microwave energy:

1. Read all instructions before using microwave oven.
2. Some products such as whole eggs and sealed containers - (for example, closed glass jars **and sealed baby bottles with teat**) may explode and should not be heated in microwave oven.
3. Use this microwave oven only for its intended use as described in this manual.
4. As with any appliance, close supervision is necessary when used by children.
5. Do not operate this microwave oven, if it is not working properly, or if it has been damaged or dropped.
6. Do not store or use this appliance outdoors.
7. Do not immerse cord or plug in water.
8. Keep cord away from heated surfaces.
9. Do not let cord hang over edge of table or counter.
10. To reduce the risk of fire in the oven cavity:
  - (a) Do not overcook food. Carefully attend microwave oven if paper, plastic, or other combustible materials are placed inside the oven to facilitate cooking.
  - (b) Remove wire twist-ties from bags before placing bag in oven.
  - (c) If materials inside the oven should ignite, keep oven door closed, turn oven off at the wall switch, or shut off power at the fuse or circuit breaker panel.
  - (d) Never leave microwave unattended while cooking or reheating.
11. Do not remove outer panel from oven.
12. Appliances are not intended to be operated by means of an external timer or separate remote-control system.
13. Failure to maintain the oven in a clean condition could lead to deterioration of the surface that could adversely affect the life of the appliance and possibly result in a hazardous situation.

#### Circuits

Your microwave ovens should be operated on a separate circuit from other appliances. The voltage used must be the same as specified on this microwave oven. Failure to do this may cause the power board fuse to blow, and/or food to cook slower. Do not insert higher value fuse in the power board.

#### Warning

- (a) The door seals and door seal areas should be cleaned with a damp cloth. The appliance should be inspected for damage to the door seals and door seal areas and if these areas are damaged the appliance should not be operated until it has been repaired by a service technician trained by the manufacturer.
- (b) It is dangerous for anyone other than a service technician trained by the manufacturer to perform repair service.
- (c) If the supply cord of this appliance is damaged, it must be replaced by the manufacturer or its service agent or a similarly qualified person in order to avoid a hazard.
- (d) Before use, the user should check that whether the utensils are suitable for use in microwave ovens.
- (e) Liquids or other foods must not be heated in sealed containers since they are liable to explode, at the same time it should avoid the boiling liquids splash.
- (f) Only allow children to use the oven without supervision when adequate instructions have been given so that the child is able to use the oven in a safe way and understands the hazards of improper use.

# Installation and General Instructions

## General Use

1. In order to maintain high quality, do not operate the oven when empty. The microwave energy will reflect continuously throughout the oven if no food or water is present to absorb energy. This can lead to damage to the microwave oven including arcing within the oven cavity.
2. If smoke is observed, press the **Stop/Reset** Pad or return "TIMER/WEIGHT SELECT DIAL" back to zero, and leave door closed. Disconnect the power cord, or shut off power at the fuse or circuit breaker panel.
3. Do not dry clothes, newspapers or other materials in oven. They may catch on fire.
4. Do not use recycled paper products, as they may contain impurities which may cause sparks and/or fires when used.
5. Do not use newspapers or paper bags for cooking.
6. Do not hit or strike control panel. Damage to controls may occur.
7. POT HOLDERS may be needed as heat from food is transferred to the cooking container and from the container to the glass tray. The glass tray can be very hot after removing the cooking container from the oven.
8. Do not store flammable materials next to, on top of, or in the oven. It could be a fire hazard.
9. Do not cook food directly on glass tray unless indicated in recipes. (Food should be placed in a suitable cooking utensil.)
10. DO NOT use this oven to heat chemicals or other non-food products. DO NOT clean this oven with any product that is labeled as containing corrosive chemicals. The heating of corrosive chemicals in this oven may cause microwave radiation leaks.
11. If glass tray is hot, allow to cool before cleaning or placing in water.
12. During cooking, some steam will condense inside and/or on the oven door. This is normal and safe. Steam will disappear after the oven is cool down.

## Placement of Oven

1. The oven must be placed on a flat, stable surface, more than 85 cm above the floor. For correct operation, the oven must have sufficient air flow. Allow 15 cm of space on the top of the oven, 10 cm at back and 10 cm on both sides. If one side of the oven is placed flush to a wall, the other side or top must not be blocked. Do not remove feet.

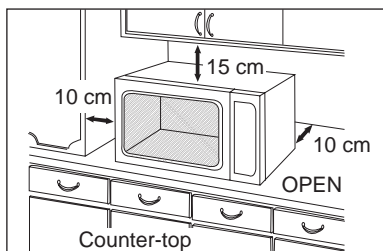

- (a) Do not block air vents. If they are blocked during operation, the oven may overheat. If the oven overheats, a thermal safety device will turn the oven off. The oven will remain inoperable until it has cooled.
  - (b) Do not place oven near a hot or damp surface such as a gas stove, electric range or sink etc.
  - (c) Do not operate oven when room humidity is too high.
2. This oven was manufactured for household use only.
  3. The microwave oven shall not be placed in a cabinet.

## Food

1. Do not use your oven for home canning or the heating of any closed jar. Pressure will build up and the jar may explode. In addition, the microwave oven cannot maintain the food at the correct canning temperature. Improperly canned food may spoil and be dangerous to consume.
2. Do not attempt to deep fat fry in your microwave oven.
3. Do not boil eggs in their shell (unless otherwise stated in cookbook). Pressure will build up and the eggs will explode.
4. Potatoes, apples, egg yolks, whole squash and sausages are examples of foods with nonporous skins. This type of food must be pierced before cooking, to prevent bursting.
5. When heating liquids, e.g. soup, sauces and beverages in your microwave oven, overheating the liquid beyond boiling point can occur without evidence of bubbling. This could result in a sudden boil over the hot liquid. To prevent this possibility the following steps should be taken.
  - (a) Avoid using straight-sided containers with narrow necks.
  - (b) Do not overheat.
  - (c) Stir the liquid before placing the container in the oven and again halfway through cooking time.
  - (d) After heating, allow to stand in the oven for a short time, stirring again before carefully removing the container.
6. **DO NOT USE A CONVENTIONAL MEAT THERMOMETER IN THE MICROWAVE OVEN. To check the degree of cooking of roasts and poultry use a MICROWAVE THERMOMETER.** Alternatively, a conventional meat thermometer may be used after the food is removed from the oven. If undercooked, return meat or poultry to the oven and cook for a few more minutes at the recommended power level. It is important to ensure that meat and poultry are thoroughly cooked.
7. **COOKING TIMES given in the cookbook are APPROXIMATE.** Factors that may affect cooking time are preferred degree of moisture content, starting temperature, altitude, volume, size, shape of food and utensils used. As you become familiar with the oven, you will be able to adjust for these factors.
8. It is better to **UNDERCOOK RATHER THAN OVERCOOK** foods. If food is undercooked, it can always be returned to the oven for further cooking. If food is overcooked, nothing can be done. Always start with minimum cooking times recommended.
9. Extreme care should be taken when cooking popcorn in a microwave oven. Cook for minimum time as recommended by manufacturer. Use the directions suitable for the wattage of your microwave oven. **NEVER** leave oven unattended when popping popcorn.
10. When heating food in plastic or paper containers, check the oven frequently due to the possibility of ignition.
11. The contents of feeding bottles and baby food jars are to be stirred or shaken and the temperature is to be checked before consumption, in order to avoid burns.

# Feature Diagram

## NN-ST340W

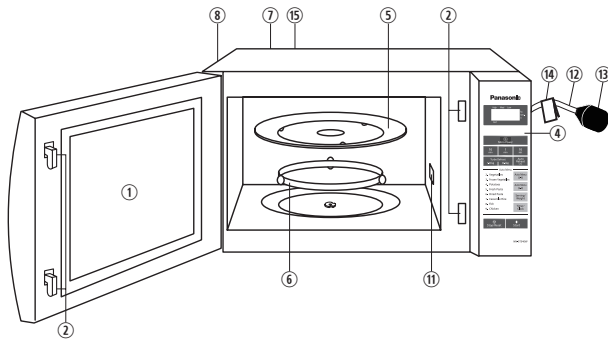

## NN-SM330W

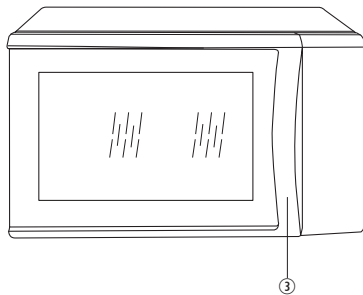
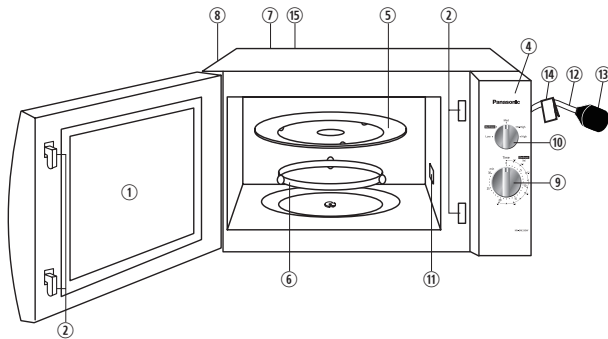

- ① **Oven Window**
- ② **Door Safety Lock System**
- ③ **Pull Door Handle**  
Pull to open the door. Opening the door during cooking will stop the cooking process without cancelling the program. It is quite safe to open the door at any time during a cooking program and there is no risk of Microwave exposure. For NN-ST340W model, cook resumes as soon as the door is closed and **Start Pad** is pressed.
- ④ **Control Panel**
- ⑤ **Glass Tray**
  - a. **DO NOT** operate the oven without the Roller Ring and Glass Tray in place.
  - b. Only use the Glass Tray specifically designed for this oven. Do not substitute any other Glass Tray.
  - c. If the Glass Tray is hot, allow to cool before cleaning or placing in water.
  - d. **DO NOT** cook directly on the Glass Tray. Always place food on a microwave-safe dish, or on a rack set in a microwave-safe dish.
  - e. If food or utensil on the Glass Tray touches oven walls, causing the tray to stop moving, the tray will automatically rotate in the opposite direction. This is normal.
  - f. Glass Tray can rotate in either direction.
- ⑥ **Roller Ring**
  - a. Roller Ring should be cleaned regularly to avoid excessive noise.
  - b. Roller Ring and Glass Tray should be used at the same time.
- ⑦ **Identification Plate**
- ⑧ **Oven Air Vent**
- ⑨ **Time/Weight Select Dial**
- ⑩ **Cook Mode Select Dial**
- ⑪ **Waveguide Cover** (do not remove)
- ⑫ **Power Supply Cord**
- ⑬ **Power Supply Plug**
- ⑭ **Power Supply Cord Label**
- ⑮ **Warning Label**

**Note:**  
The illustration is for reference only.

# Control Panel (NN-ST340W)

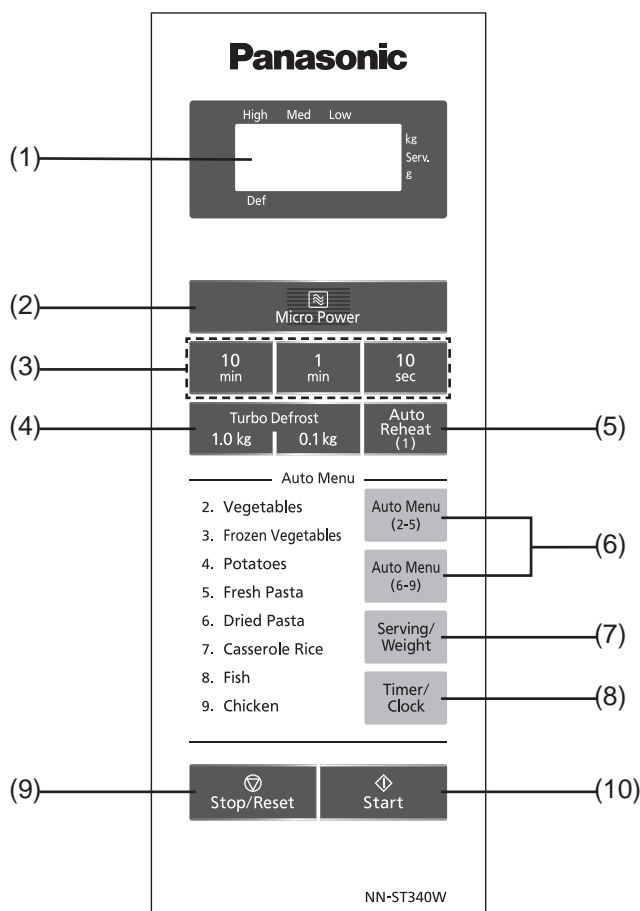

- (1) **Display Window**
- (2) **Micro Power Pad** (pg. 7)
- (3) **Time Pads**
- (4) **Turbo Defrost Pads** (pg. 8)
- (5) **Auto Reheat Pad** (pg. 9)
- (6) **Auto Cook Pads** (pg. 9)
- (7) **Serving/Weight Pad**
- (8) **Timer/Clock Pad** (pg. 5, 11)
- (9) **Stop/Reset Pad**

**Before cooking:** One tap clears all your instructions.

**During cooking:** One tap temporarily stops the cooking process. Another tap cancels all your instructions and colon or time of day appears in the display window.

**(10) Start Pad**

After cooking program setting, one tap allows oven to begin functioning. If door is opened or **Stop/Reset** Pad is pressed once during oven operation, **Start** Pad must be pressed again to restart oven.

**Beep Sound:**

When a pad is pressed correctly, a beep will be heard.

If a pad is pressed and no beep is heard, the unit did not or cannot accept the instruction. The oven will beep twice between programmed stages. At the end of any complete program, the oven will beep 5 times.

**Note:**

If an operation is set and **Start** Pad is not pressed, after 6 minutes, the oven will automatically cancel the operation. The display will revert back to clock or colon mode.

# Setting Clock (NN-ST340W)

To Set Clock: **Example: To set 11:25 a.m.**

English

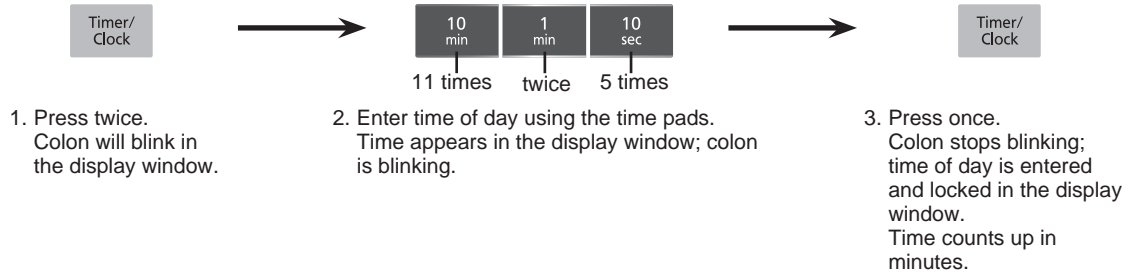

## Notes:

1. To reset time of day, repeat steps 1-3.
2. The clock will keep the time of day as long as oven is plugged in and electricity is supplied.
3. Clock is a 12-hour display.
4. Oven will not operate while colon is blinking.

# To Use Child Safety Lock (NN-ST340W)

To set:



To cancel:



## Notes:

1. Child Safety Lock can be set when colon or time of day is displayed.
2. This feature allows you to prevent operation of the oven by a young child; however, the door will open.
3. To set or cancel child safety lock, **Start** pad or **Stop/Reset** pad must be pressed 3 times within 10 seconds.

# Operation (NN-SM330W)

English

## To Set Cooking Program

1. Put the food into the oven

2. Set the Power Level

3. Set Cooking Time

Note: When selecting the time for shorter than 5 minutes, turn Time/Weight Select Dial past 5 minutes and then return to the correct time.

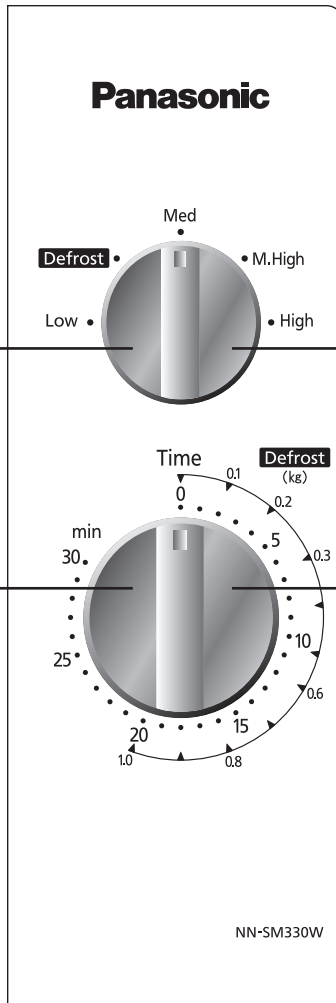

## To Defrost by Setting Weight of Food

1. Put the food into the oven

2. Set the Power Level at Defrost

3. Set the Weight of Food

Note: When selecting weight for less than 0.2 kg, turn Time/Weight Select Dial past 0.2 kg and then return to correct weight.

Power Level	Example of Use
HIGH	Boil water. Cook fresh fruit, vegetables, rice, pasta, noodles.
MEDIUM-HIGH	Cook poultry, meat, cakes, desserts and heat milk.
MEDIUM	Cook pot roasts, casseroles and meat loaves, melt chocolate. Cook eggs and cheeses. Cook fish.
DEFROST	Thaw foods.
LOW	Keep cooked foods warm, simmer slowly.

### Notes:

- As soon as the TIME/WEIGHT SELECT DIAL is turned, the oven will start cooking the food.
- ALWAYS RETURN TIME/WEIGHT SELECT DIAL BACK TO "0" position if food is removed from oven before set cooking time is complete and when oven is not in use.
- TO STOP OVEN when a cooking program is set, open the door—microwaves automatically stop entering the oven cavity because of the safety door lock system. If the remaining cooking time is not required, turn the Time/Weight Select Dial back to "0" before closing the door.

# Operation (NN-ST340W)

## To Set Power and Time

English

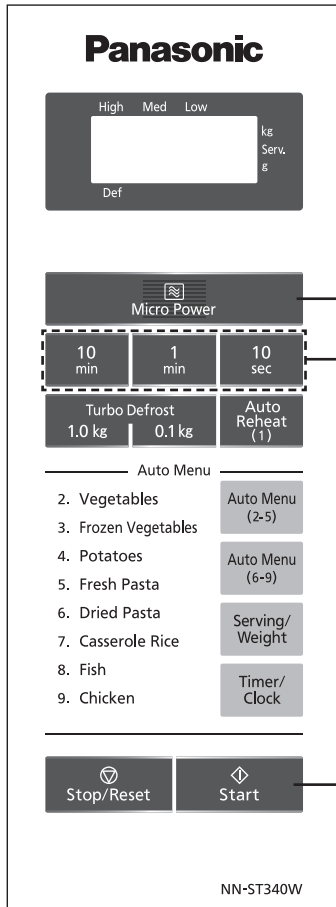

1. Put the food into the oven

2. Press to Select Power

(see chart below)

No. of taps	Power Level	Example of Use
1	HIGH	Boil water. Cook fresh fruit, vegetables, rice, pasta and noodles.
2	MEDIUM-HIGH	Cook poultry, meat, cakes, desserts, heat milk.
3	MEDIUM	Cook pot roasts, casseroles and meat loaves, melt chocolate. Cook eggs and cheeses. Cook fish.
4	DEFROST	Thaw foods.
5	LOW	Keep cooked foods warm, simmer slowly.

3. Set Cooking Time

(High Power: up to 30 minutes  
Other Powers: up to 99 minutes 50 seconds)

4. Press

The time in the display window will count down.

### Note:

It is possible to programme no more than 3 stages cooking as one cooking set. For 2 or 3 stages cooking, repeat steps 2 and 3 above before pressing **Start** Pad. When operating, two beeps will be heard between each stage. This feature is not available for Auto Menu and Turbo Defrost.

**Example: Continually set [High power] 2 minutes, [Medium power] 3 minutes and [Low power] 2 minutes.**

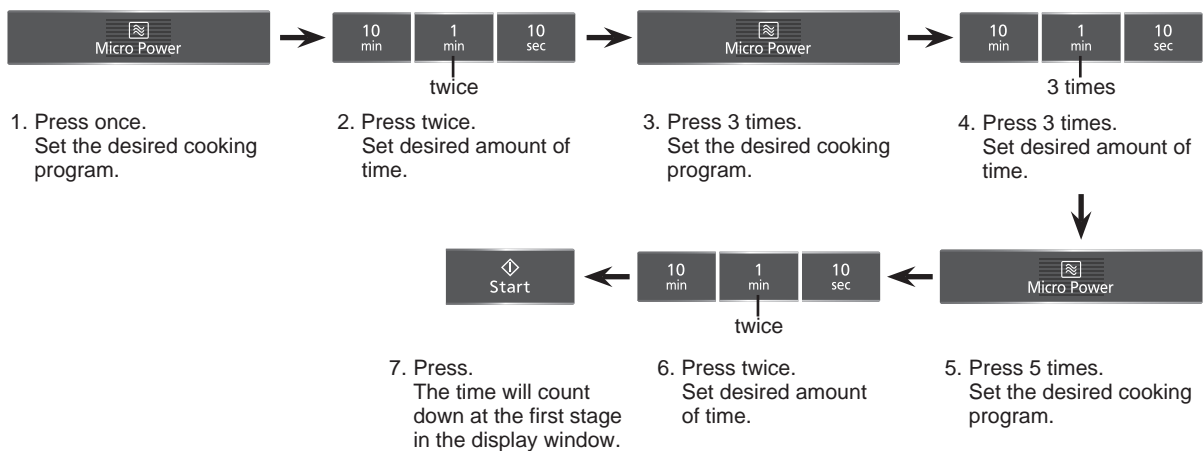

**Note:** When selecting high power on the first stage, you can skip step 1.

## To Use Turbo Defrost (0.1~2.0 kg):

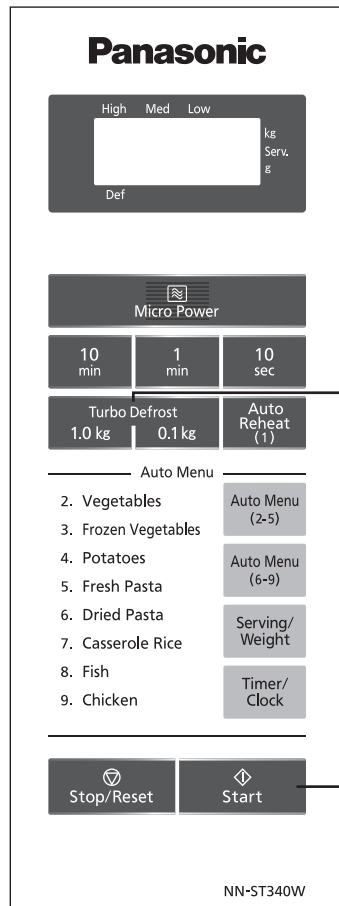

1. Put the food into the oven

2. Select the Weight of Food

Example: To defrost 1.5 kg of meat.

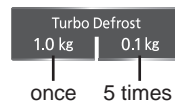

Food	Maximum Weight
Minced meat, Chicken Pieces, Chops	2 kg
Beef roast, lamb, whole chickens	2 kg
Whole fish, scallops, prawns, fish fillets	1 kg

3. Press

Defrosting time appears in the display window and begins to count down.

### Notes:

1. Turbo Defrost can be used to defrost many cuts of meat, poultry and fish by weight. To use, simply program Turbo Defrost and the weight of the food in kg (1.0) and tenths of a kg (0.1). The oven will determine the defrosting time and power levels. Once the oven is programmed, the defrosting time will appear in the display. For best results the minimum recommended weight is 0.2 kg.
2. BONE-IN ROASTS, such as a Beef Rib Roast have a smaller muscle than a boneless roast of the same weight. Therefore, for bone-in roasts weighing over 2 kg reduce weight by 0.5 kg. For bone-in roasts weighing less than 2 kg, reduce weight by 0.25 kg.
3. Turn over or remove or shield food when buzzer rings.

## To Reheat/Cook using Auto Cook Pads

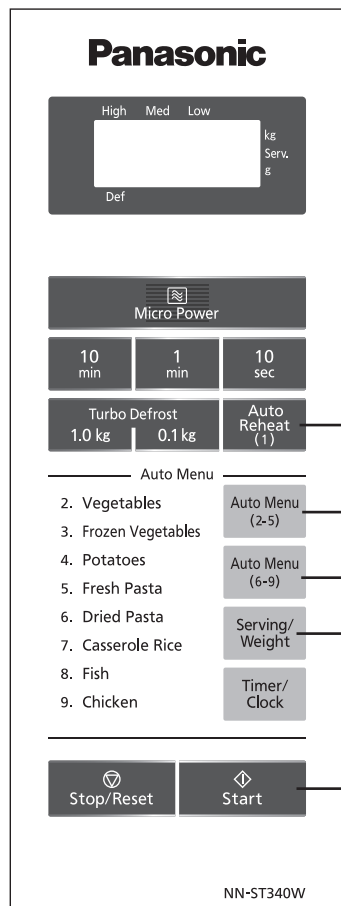

**1. Put the food into the oven**

**2. Select desired Auto Menu Pad**

Select and press the appropriate pad for the food you are cooking until the desired menu number appears in the display window.

**3. Select desired Serving/Weight**

Press the Serving/Weight pad until the desired serving or weight appears in the display window.

**4. Press**

The time in the display window will count down.

Menu No.	Category	Serving/Weight			
		1 tap	2 taps	3 taps	4 taps
1	Auto Reheat	200 g	400 g	600 g	800 g
2	Vegetables	120 g	180 g	250 g	370 g
3	Frozen Vegetables	150 g	300 g	450 g	600 g
4	Potatoes	200 g	400 g	600 g	-
5	Fresh Pasta	150 g	250 g	375 g	-
6	Dried Pasta	150 g	250 g	375 g	-
7	Casserole Rice	100 g	200 g	300 g	-
8	Fish	100 g	200 g	300 g	400 g
9	Chicken	200 g	400 g	600 g	800 g

## 1. Auto Reheat

Pre-cooked foods are reheated automatically by setting the food's weight. You need not select power level or reheating time. The foods should be at refrigerator temperature (5-7°C). Use suitable size microwave safe bowl, add 1-4 tbsp of water, and cover with a microwave safe plastic wrap. Stir after beep sounds. After cooking, stir the food.

**Note:** When reheating items such as soups, stews, and casseroles, it is recommended that they are stirred at half of reheating time and at completion of reheating.

## 2. Vegetables

Suitable for cooking all types of leaf, green and soft varieties, including broccoli, squash, cauliflower, cabbage, asparagus, beans, celery, zucchini, spinach, capsicum or a mixture of these. All vegetables should be trimmed or prepared and cut into even size pieces. Add 2-4 tablespoons water if vegetables appear slightly dehydrated. Add water if you prefer a softer cooked texture. Place in a suitable size dish. Butter, herbs etc. may be added before heating, but do not add salt until serving. Cover with plastic wrap or a well fitting lid. Stir after beep sounds.

## 3. Frozen Vegetables

Suitable for all types of frozen vegetables, like frozen peas, sweetcorn or mixed vegetables. Place prepared vegetables into a container. Add 2-6 tablespoons of water. Cover with pierced cling film or lid. The oven will 'beep' to prompt you to stir the vegetables.

## 4. Potatoes

Potatoes can be trimmed or prepared and cut into evenly sliced pieces. If you cook whole potatoes, you can pierce first. If dehydrated or softer texture is desired. Place in a appropriate size dish and cover with plastic wrap or well fitting lid. Halfway through the cooking time, the oven will 'beep' to prompt you to stir potatoes.

## 5. Fresh Pasta

Suitable for cooking fresh pasta. Place the pasta into a suitable size microwave-safe dish with boiling water. Use the following as a guide:

Pasta	Boiling Water
150 g	3 cups
250 g	4 cups
375 g	5 cups

Leave dish uncovered. The oven will 'beep' to prompt you to stir.

## 6. Dried Pasta

Suitable for cooking dried pasta. Place the pasta into a suitable size microwave-safe dish with boiling water. Use the following as a guide:

Pasta	Boiling Water
150 g	4 cups
250 g	5 cups
375 g	6 cups

Add a little oil before cooking to prevent pasta from sticking together. Cook without lid. Stir after beep sounds.

## 7. Casserole Rice

It is suitable for cooking white rice including short, long grain, jasmine and basmati. Place rice in a suitable size microwave safe casserole. Add recommended water listed below. Allow at least ½ depth of volume for evaporation to prevent boiling over. Cover with lid.

Rice	Recommended Water
100 g	150 ml
200 g	300 ml
300 g	450 ml

## 8. Fish

It is suitable for cooking whole fish and fish fillets. Put the prepared fish in a microwave safe dish. Add recommended sauce and water listed below. Cover dish securely with plastic wrap.

Fish	Recommended Sauce and Water
100 g	1 tbsp sauce and little water
200 g	2 tbsps sauce and little water
300 g	3 tbsps sauce and little water
400 g	4 tbsps sauce and little water

## 9. Chicken

It is suitable for cooking chicken pieces such as wings, drumsticks, thighs, half breasts etc. Pierce the chicken pieces before cooking. Place prepared chicken pieces in a suitable size microwave safe casserole. Add 1-5 tbsp oil if desired. Cover with lid. Stir after beep sounds.

## Timer Setting (Kitchen Timer/Standing Time/Delay Time)

This feature allows you to program standing time after cooking is completed and to program the oven as a minute or 10 seconds timer or program delay start.

### To use as a Kitchen Timer: **Example: To count 5 minutes**

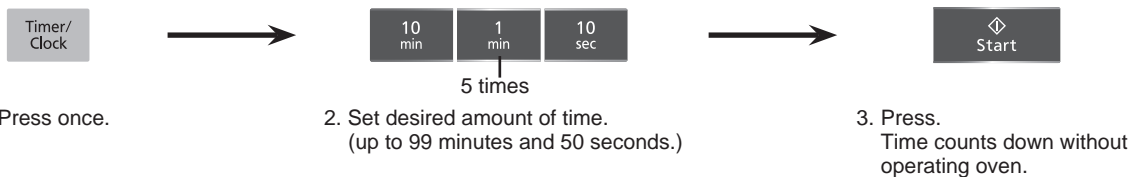

1. Press once.
2. Set desired amount of time.  
(up to 99 minutes and 50 seconds.)
3. Press.  
Time counts down without operating oven.

### To Set Standing Time: **Example: To stand for 5 minutes after cooking (3 mins. at Medium)**

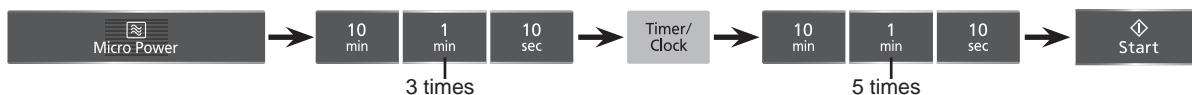

1. Press 3 times.  
Set the desired cooking program. (See page 7 for directions.)
2. Press 3 times.  
Set the desired cooking time.  
(High Power: up to 30 minutes.)  
(Other Powers: up to 99 minutes and 50 seconds.)
3. Press once.
4. Press 5 times.  
Set desired amount of standing time.  
(Up to 99 minutes and 50 seconds.)
5. Press.  
Cooking starts. After cooking, standing time will count down without operating oven.

### To Set Delay Start: **Example: To start cooking 5 minutes later (3 mins. at Medium)**



1. Press once.
2. Press 5 times.  
Set desired amount of delay time.  
(Up to 99 minutes and 50 seconds.)
3. Press 3 times.  
Set the desired cooking program. (See page 7 for directions.)
4. Press 3 times.  
Set the desired cooking time.  
(High Power: up to 30 minutes.)  
(Other Powers: up to 99 minutes and 50 seconds.)
5. Press.  
Delayed time counts down. After delay time, cooking will start.

## Notes:

1. If oven door is opened while Standing Time, Delay Start or Kitchen Timer has been set, the time in the display window will continue to count down.
2. Delay Start and Standing Time can not be programmed before any Auto control Function. This is to prevent the standing temperature of the food from rising before defrosting or cooking begins. A change in the starting temperature could cause in accurate results.
3. When using Standing Time or Delay Start, it's up to 2 Power stages.

# Before Requesting Service

## ALL THESE THINGS ARE NORMAL:

The oven causes interference with my TV.	Some radio and TV interference might occur when you cook with the microwave oven. This interference is similar to the interference caused by small appliances such as mixers, vacuums, hair dryers, etc. It does not indicate a problem with your oven.
The oven lights dim.	When cooking with a power other than HIGH, the oven must cycle to obtain the lower power levels. The oven light will dim and clicking noises can be heard when the oven cycles.
Steam accumulates on the oven door and warm air comes from the oven vents.	During cooking, steam and warm air are given off from the food. Most of the steam and warm air are removed from the oven by the air which circulates in the oven cavity. However, some steam will condense on cooler surfaces such as the oven door. This is normal and safe. Steam will disappear after the oven is cool down.
I accidentally operate my microwave oven without any food in it.	Operating the oven empty for a short time will not damage the oven. However, we do not recommend this to be done.

PROBLEM	POSSIBLE CAUSE	REMEDY
<b>For All models:</b>		
Oven will not turn on.	The oven is not plugged in securely.	Remove plug from outlet, wait 10 seconds and re-insert.
	Circuit breaker or fuse is tripped or blown.	Contact the specified service center.
	There is a problem with the outlet.	Plug another appliance into the outlet to check if the outlet is working.
When the oven is turning on, there is noise coming from Glass Tray.	The roller ring and oven bottom are dirty.	Clean these parts according to care of your oven (See next page).
Oven will not start cooking.	The door is not closed completely.	Close the oven door securely.
<b>For NN-ST340W only:</b>		
Oven will not start cooking.	<b>Start</b> Pad was not pressed after programming.	Press <b>Start</b> Pad.
	Another program has already been entered into the oven.	Press <b>Stop/Reset</b> Pad to cancel the previous program and program again.
	The program has not been entered correctly.	Program again according to the Operating Instructions.
	<b>Stop/Reset</b> Pad has been pressed accidentally.	Program oven again.
The word "Child" appears in the display window.	The Child Safety Lock was activated by pressing <b>Start</b> Pad 3 times.	Deactivate Lock by pressing <b>Stop/Reset</b> Pad 3 times.

If it seems there is a problem with the oven, contact an authorized Service Center.

# Care of your Microwave Oven

1. Turn the oven off and remove the power plug from the wall socket before cleaning, if possible.
2. Keep the inside of the oven clean. When food splatters or spilled liquids adhere to oven walls, wipe with a damp cloth. Mild detergent may be used if the oven gets very dirty. The use of harsh detergent or abrasives is not recommended.
3. The outside oven surfaces should be cleaned with a damp cloth. To prevent damage to the operating parts inside the oven, water should not be allowed to seep into the ventilation openings.
4. Do not allow the Control Panel to become wet. Clean with a soft, damp cloth. Do not use detergents, abrasives or spray-on cleaners on the Control Panel.  
When cleaning the Control Panel, leave oven door open to prevent oven from accidentally turning on. After cleaning press **Stop/Reset** Pad to clear display window or make sure TIMER/WEIGHT SELECT DIAL is set to zero position.
5. If steam accumulates inside or around the outside of the oven door, wipe with a soft cloth. This may occur when the microwave oven is operated under high humidity conditions and in no way indicates malfunction of the unit.
6. It is occasionally necessary to remove the glass tray for cleaning. Wash the tray in warm sudsy water or in a dishwasher.
7. The roller ring and oven cavity floor should be cleaned regularly to avoid excessive noise. Simply wipe the bottom surface of the oven with mild detergent, water or window cleaner and dry. The roller ring may be washed in mild sudsy water or dish washer. Cooking vapors collect during repeated use but in no way affect the bottom surface or roller ring wheels. When removing the roller ring from cavity floor for cleaning, be sure to replace in the proper position.
8. When it becomes necessary to replace the oven light, please consult a dealer to have it replaced.
9. The oven should be cleaned regularly and any food deposits removed.

## Technical Specifications











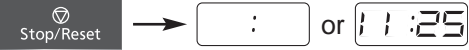

Model:	NN-SM330WPTE/KTE	NN-SM330WKPQ	NN-ST340WPTE/KTE	NN-ST340WSTM	NN-ST340WKPQ
Power Supply:	220 V 50 Hz	230-240 V 50 Hz	220 V 50 Hz	220 V 50-60 Hz	230-240 V 50 Hz
Power Consumption:	5.3 A 1,125 W	4.9 A 1,125 W	6.2 A 1,275 W	8.3 A 1,725 W	5.9 A 1,300 W
Cooking Power*:	700 W		800 W		
Outside Dimensions (W x H x D):	488 mm x 279 mm x 405 mm				
Oven Cavity Dimensions (W x H x D):	315 mm x 206 mm x 353 mm				
Overall Cavity Volume:	23 L				
Glass Tray Diameter:	Ø245 mm		Ø285 mm		
Operating Frequency:	2,450 MHz				
Net Weight:	Approx. 12.0 kg		Approx. 12.5 kg		

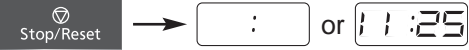
\* IEC Test Procedure

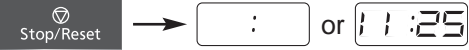
Specifications subject to change without notice.

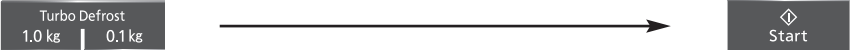
As for the voltage requirement, the production month, country and serial number, please refer to the identification plate on the microwave oven.

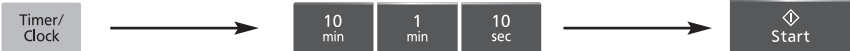
# Quick Guide (NN-ST340W)

Feature	How to Operate		
<b>To Set Clock</b> (page 5)	 <p>Press twice. Set Time of day. Press once.</p>		
<b>To Set / Cancel Child Safety Lock</b> (page 5)	<table border="0" style="width: 100%;"> <tr> <td style="width: 50%; vertical-align: top;"> <b>To Set:</b>   <p>Press 3 times.</p> </td> <td style="width: 50%; vertical-align: top;"> <b>To Cancel:</b>   <p>Press 3 times.</p> </td> </tr> </table>	<b>To Set:</b>  <p>Press 3 times.</p>	<b>To Cancel:</b>  <p>Press 3 times.</p>
<b>To Set:</b>  <p>Press 3 times.</p>	<b>To Cancel:</b>  <p>Press 3 times.</p>		
<b>To Cook / Reheat / Defrost by Micro Power and Time Setting</b> (page 7)	 <p>Select power. Set the cooking time. Press.</p>		
<b>To Use Turbo Defrost Pads</b> (page 8)	 <p>Select the weight of food. Press.</p>		
<b>To Reheat using Auto Reheat Pad</b> (page 9)	 <p>Press once. Press to select the weight. Press.</p>		
<b>To Cook using Auto Cook Pads</b> (page 9)	<p>eg:</p>  <p>Press to select the desired category number. Press to select the weight. Press.</p>		
<b>To Use as a Kitchen Timer</b> (page 11)	 <p>Press. Set the kitchen time. Press.</p>		
<b>To Set Standing Time</b> (page 11)	<p>Set the desired cooking program.</p>  <p>Press. Set the standing time. Press.</p>		
<b>To Set Delay Start</b> (page 11)	 <p>Press. Set the delay time. Set the desired cooking program. Press.</p>		

# Introduction

## Cooking with Microwave Energy

Microwaves are a form of high frequency electromagnetic waves (approx 12cm wavelength) similar to those used by a radio. Electricity is converted into microwave energy by the magnetron tube. The microwaves travel from the magnetron tube to the oven cavity where they are reflected, transmitted or absorbed.

English

### Reflection

Microwaves are reflected by metal just as a ball is bounced off a wall. A combination of stationary (interior walls) and rotating metal (turntable or stirrer fan) helps assure that the microwaves are well distributed within the oven cavity to produce even cooking.

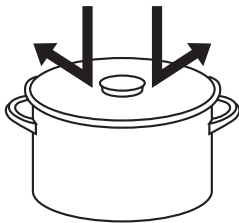

### Transmission

Microwaves pass through some materials such as paper, glass and plastic much like sunlight shining through a window. Because these substances do not absorb or reflect the microwave energy, they are ideal materials for microwave oven cooking containers.

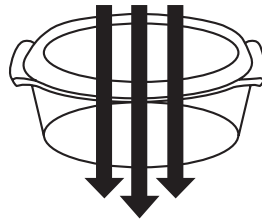

### Absorption

Microwaves are absorbed by food. They penetrate to a depth of about 2 to 4cm. Microwave energy excites the molecules in the food (especially water, fat and sugar molecules), and causes them to vibrate very quickly. The vibration causes friction and heat is produced. In large foods, the heat which is produced by friction is conducted to the center to finish cooking.

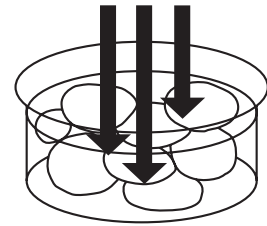

# Cookware and Utensil Guide

	Microwave Oven
Aluminum Foil	For Shielding
Grill Tray	No
Browning Dish	Yes
Browning Paper Bags	No
Dinnerware: Oven/Microwave Safe	Yes
Non Oven/Microwave Safe	No
Disposable Polyeser Paperboard Dishes	Yes
Glassware: Oven Glassware & Ceramic	Yes
Non-heat Resistant	No
Metal Cookware	No
Metal Twist-ties	No
Oven Cooking Bag	Yes
Oven Rack	No
Paper Towels and Napkins	Yes
Plastic Dishes: Microwave Safe	Yes
Non-microwave Safe	No
Plastic Wrap	Yes
Straw, Wicker, Wood	Yes
Thermometers: Microwave Safe	Yes
Conventional	No
Wax Paper	Yes

# Microwave Cooking Techniques



## Dish Size

Follow the dish sizes given in the recipes, as these affect the cooking times. A quantity of food spread in a bigger dish cooks more quickly.

## Standing Time

Dense foods e.g. meat, jacket potatoes and cakes, require **STANDING TIME** (inside or outside of the oven) after cooking, to allow heat to finish conducting to cook the centre completely.

### **Meat Joints**

Stand 15 mins. wrapped in tin foil.

### **Jacket Potatoes**

Stand 10 mins. wrapped in tin foil.

### **Light Cakes**

Stand 5 mins. before removing from dish.

### **Rich dense Cakes**

Stand 15-20 mins.

## Cling Film

Cling film helps keep the food moist and the trapped steam assists in speeding up cooking times. However, it should be pierced before cooking, to allow excess steam to escape. Always take care when removing cling film from a dish as the build-up of steam will be very hot. Always purchase cling film that states on the packet "suitable for microwave cooking" and use as a covering only. Do not line dishes with cling film.

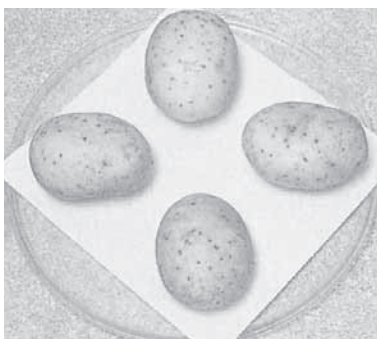

## Quantity

Small quantities cook faster than large quantities, also small meals will reheat quicker than large portions.



If food is not cooked after **STANDING TIME**, return to oven and cook for additional time.

## Moisture Content

Many fresh foods e.g. vegetables and fruit, vary in their moisture content throughout the season-jacket potatoes are a particular example of this. For this reason cooking times may have to be adjusted throughout the year. Dry ingredients e.g. rice, pasta, can dry out further during storage and cooking times may differ from ingredients freshly purchased.

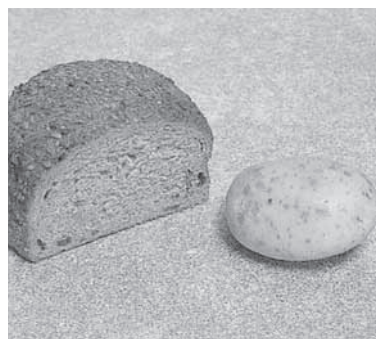

## Density

Porous airy foods heat quicker than dense heavy foods.

### **Fish**

Stand 2-5 mins.

### **Egg Dishes**

Stand 2-3 mins.

### **Precooked Convenience Food**

Stand for 5 mins.

### **Plated Meals**

Stand for 2-5 mins.

### **Vegetables**

Boiled potatoes benefit from standing 1-2 mins., however most other types can be served immediately.

## Piercing

The skin or membrane on some foods will cause steam to build up during cooking. These foods must be pierced or a strip of skin should be peeled before cooking to allow the steam to escape. Eggs, potatoes, apples, sausages etc, will all need to be pierced before cooking. **DO NOT ATTEMPT TO BOIL EGGS IN THEIR SHELLS.**

# Microwave Cooking Techniques

English



## Covering

Cover foods with microwave cling film or a self-fitting lid. Cover fish, vegetables, casseroles, soups. Do not cover cakes, sauces, jacket potatoes, pastry items.



## Starting Temperature

The colder the food, the longer it takes to heat up. Food from a fridge takes longer to reheat than food at room temperature.

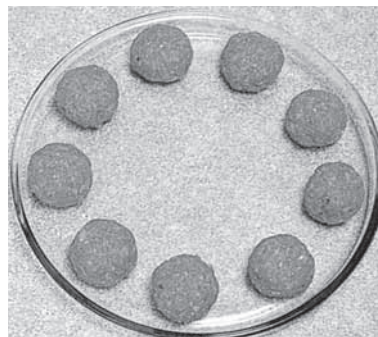

## Spacing

Foods cook more quickly and evenly if spaced apart. NEVER pile foods on top of each other.



## Turning and Stirring

Some foods require stirring during cooking. Meat and poultry should be turned after half the cooking time. All liquid must be stirred before and during heating. Water, especially must be stirred before and during heating, to avoid eruption.



## Shape

Even shapes cook evenly. Food cooks better by microwaves when in a round container rather than a square one.

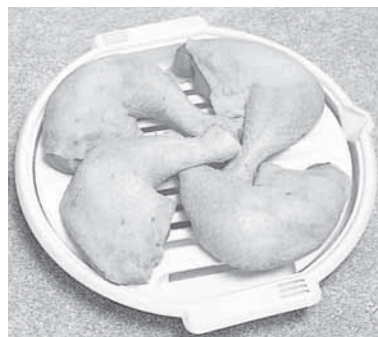

## Arranging

Individual foods e.g. chicken portions or chops, should be placed on a dish so that the thicker parts are on the outside.

## Checking Food

It is essential that food is checked during and after a recommended cooking time, even if an AUTO PROGRAM has been used (just as you would check food cooked in a convectional oven). Return the food to the oven for further cooking if necessary.

# Defrosting Guidelines/Turbo Defrost

This feature allows you to enter the weight in kilos and the oven will select the correct defrosting time for most foods. However, do not use for

porous foods e.g. bread and cakes etc.

During the defrosting process, the oven will beep to remind you to check the food i.e. turn, shield or break the food apart, as shown below.

English

## Tips for Defrosting

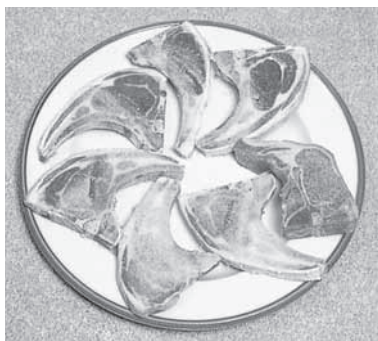

Separate chops and small items e.g. Quiche slice where possible.



Give large joints of meat further standing to ensure meat is not still icy in the center.



Break up small items e.g. scallops, minced meat, halfway through defrosting.



Remove wrappers from meat. Place on microwave rack or up-turned saucer.



Shield edges, back of fat of joints and thin edges of fish with small pieces of SMOOTH tin foil to prevent over-defrosting.

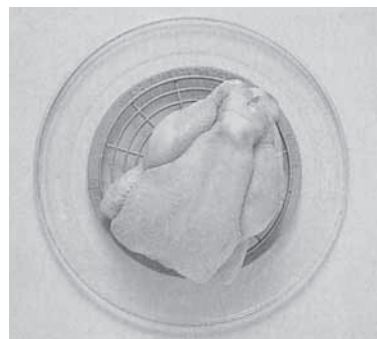

Turn dense foods and meat 2-3 times during defrosting.



# Reheating by Microwave

Check that food is piping hot before serving. If not hot enough, return to oven for further reheating.

The times given in the charts below are guidelines only, and will vary depending on STARTING temperature, dish size, etc.

- Transfer canned foods from cans to a suitable microwave safe container. Stir halfway during heating and again at the end of heating.

- Always use the glass tray when reheating.

## Stirring and Turning

Whenever possible, foods should be stirred or turned over during reheating. This helps ensure that the food reheats evenly on the outside and in the centre.

## Standing Time

Many foods require a STANDING TIME after reheating. Standing time

is a rest time which allows the heat in the food to continue to transfer to the centre, thus eliminating cold spots. If the food has been covered during the reheating time, then leave the covering on during the standing time. Standing time is particularly important for dense foods e.g. Lasagnes, Shepherd's Pie, etc. and those foods that cannot be stirred during reheating.

Food	Weight/ Quantity	Power Level	Time (approx)
<b>Breads</b>			
Croissants	1	HIGH	10 secs.
	4	HIGH	30 secs.
Naan Bread	225 g	HIGH	40 secs.
Pitta Bread	1	HIGH	20 secs.
	2	HIGH	30 secs.
Rolls	1	HIGH	10 secs.
	4	HIGH	30 secs.
<b>Canned Beans, Rice – Pasta – Stir during Heating</b>			
Baked Beans	225 g	HIGH	2 mins.
	450 g	HIGH	3 mins.
Macaroni Cheese	210 g	HIGH	1-2 mins.
	430 g	HIGH	3 mins.
Ravioli	440 g	HIGH	3-4 mins.
Spaghetti	215 g	HIGH	2 mins.
Bolognese	430 g	HIGH	3-4 mins.
Spaghetti Shapes	215 g	HIGH	1-2 mins.
	425 g	HIGH	3-4 mins.
<b>Canned Meat – Drain</b>			
Beef Curry	425 g	HIGH	3-4 mins.
Frankfurters*	300 g	HIGH	3 mins.
Hamburgers	2/160 g	HIGH	1-2 mins.
	4/425 g	HIGH	4 mins.
Irish Stew	425 g	HIGH	3-4 mins.
Meatballs & Gravy	410 g	HIGH	3-4 mins.
Meat Pudding	140 g	HIGH	1-2 mins.
Minced Beef	190 g	HIGH	1-2 mins.
	400 g	HIGH	3-4 mins.
Steak & Kidney Pudding	425 g	HIGH	4-5 mins.
Stewed Steak	400 g	HIGH	3-4 mins.
<b>Canned Soups &amp; Jars</b>			
Chicken	425 g	HIGH	3-4 mins.
Curry	540 g	HIGH	4-5 mins.
Lentil	425 g	HIGH	4-5 mins.
Prawn Bisque	425 g	HIGH	4-5 mins.
Tomato	295 g	HIGH	2-3 mins.
	800 g	HIGH	6 mins.

Food	Weight/ Quantity	Power Level	Time (approx)
<b>Canned Pudding &amp; Cartons</b>			
Creamed Rice	213 g	HIGH	1 min. 30 secs.
	425 g	HIGH	3 mins.
Sponge Pudding	300 g	HIGH	1-2 mins.
Custard	150 g	HIGH	50 secs.
	290 g	HIGH	1 min. 40 secs.
	532 g	HIGH	3 mins.
<b>Canned Vegetables-* Do not drain</b>			
Asparagus Spears	340 g	HIGH	2 mins.
Beans, butter	439 g	HIGH	2 mins.
Chilli*	415 g	HIGH	3-4 mins.
Green cut	410 g	HIGH	2-3 mins.
Kidney	432 g	HIGH	2 mins. 30 secs.
Cabbage Saute*	397 g	HIGH	3-4 mins.
Carrots, cut	300 g	HIGH	1 min. 30 secs.
Carrots, whole	397 g	HIGH	1 min. 30 secs.
	539 g	HIGH	2 mins.30 secs.
Corn Niblets	326 g	HIGH	2 mins. 30 secs.
Corn Creamed	298 g	HIGH	2-3 mins.
Mixed Vegetables	410 g	HIGH	2-3 mins.
Mushrooms, Creamed	213 g	HIGH	2 mins. 30 secs.
	300 g	HIGH	1-2 mins.
Whole Pudding*	430 g	HIGH	3 mins.
	300 g	HIGH	1-2 mins.
Peas, Garden	145 g	HIGH	50-60 secs.
	300 g	HIGH	2 mins.
Marrowfat	300 g	HIGH	2 mins.
	300 g	HIGH	2-3 mins.
Potatoes, new	283 g	HIGH	1 min. 30 secs.
	540 g	HIGH	3-4 mins.
	780 g	HIGH	3-4 mins.
Tomatoes	227 g	HIGH	2 mins
	397 g	HIGH	2 mins.
	780 g	HIGH	3-4 mins.

# Common Queries Answered

English

Problem	Cause	Solution
Food cools quickly after being MICROWAVED.	Food not cooked through.	Put back in oven for extra time. Remember foods at fridge temperature require more cooking time than food at room temperature.
Soup/Casserole boils over after cooking by MICROWAVE.	Container too small.	For liquid foods use container twice the volume of food.
Food cooks too slowly when cooked by MICROWAVE.	Oven not receiving correct power.	Oven should be on a separate 13 amp circuit.
	Food temperature from fridge colder than room temperature.	Extra time required for cooking colder foods.
Meat is tough when cooked by MICROWAVE.	Power setting too high.	Use reduced power level for meats.
	Meat salted before cooking.	Do not salt before cooking. Salt if necessary after cooking.
Cakes remain uncooked in center when cooked by MICROWAVE.	Too short cooking and/or standing time.	Add extra cooking time/standing time.
Scrambled or poached eggs tough and rubbery when cooked by MICROWAVE.	Cooking time too long.	Take care cooking small quantities of eggs, once spoiled they cannot be saved.
Quiche/Egg custards tough and rubbery when cooked by MICROWAVE.	Power level too high.	Use reduced power levels for these items.
Cheese sauce tough and stringy when cooked by MICROWAVE.	Cheese cooked with sauce.	Add at the end of cooking time, the heat of the sauce will melt the cheese.
Vegetables are dry when cooked by MICROWAVE.	Cooked uncovered. Low moisture content e.g. old root vegetables. Salt added before cooking.	Cover with a lid or cling film. Add extra 2-4 tbsps of water. Slat after cooking.
Condensation appears on the door of your oven.	This is normal and means the food is cooking faster than the moisture can be expelled from the oven.	Wipe condensation off with a soft cloth.
Turntable rotates in both directions.		This is normal.

# European Recipes



Pate

## Meatballs in Tomato Mint Sauce

Serves : 4 – 6

### Ingredients:

500 g mince  
375 g fresh breadcrumbs  
1 onion chopped  
1 clove garlic, crushed  
1 large egg, lightly beaten  
15 ml Worcestershire sauce  
15 ml tomato sauce  
60 g freshly chopped mixed herbs  
ground black pepper  
1 small onion, chopped  
15 g pine nuts  
15 g butter  
250 g tomato purée  
15 g chopped mint  
30 g grated Parmesan cheese

### Method:

Place mince, breadcrumbs, onion, garlic, egg, Worcestershire sauce, tomato sauce, herbs, and pepper in a large bowl and mix well. Roll mixture into 2.5 cm balls. Place half the meatballs onto a paper towel-lined dinner plate, evenly spaced. Cook on MEDIUM- HIGH for 3 to 4 minutes, turning halfway through cooking. Set aside.

Repeat above procedure with remaining meatballs. Place onion, pine nuts and butter in a 500 ml jug and cook on HIGH for 2 to 3 minutes. Add tomato purée and mint, and stir well. Place meatballs and sauce in a 2-litre dish and combine gently. Sprinkle with Parmesan cheese and heat on MEDIUM-HIGH for 4 to 5 minutes.

## Tomato Soup

Serves : 4-6

### Ingredients:

30 g butter  
1 kg ripe tomatoes, peeled and chopped  
1 onion, sliced  
1 carrot, sliced  
625 ml chicken stock  
5 g oregano  
salt & pepper to taste

### Method:

Place butter in a 4-litre casserole dish and heat on HIGH for 30 to 60 seconds. Add vegetables. Cook on HIGH for 8 to 10 minutes. Pour in stock and oregano. Cover and cook on HIGH for 15 minutes. Purée in a food processor or blender. Season to taste with salt and pepper. Serve in individual soup bowls.

## Pate

Makes : 500 ml

### Ingredients:

1 small onion, finely chopped  
1 clove garlic, crushed  
125 g butter  
375 g chicken livers, trimmed and cut in half  
2 g pepper  
30 ml sour cream

### Method:

Place onion, garlic and butter in a small casserole dish. Cook on High for 4 to 5 minutes. Add chicken livers and pepper to mixture. Cover and cook on MEDIUM- HIGH for 6 to 7 minutes, stirring halfway through cooking. Set aside and allow to cool. Place cooled mixture in a blender or food processor. Add sour cream and blend until smooth. Pour into a 500-ml mould and refrigerate until set.

## Mexican Dip

### Ingredients:

310 g can red kidney beans  
60 ml oil  
125 g grated cheese  
2 g salt  
5-7 g chilli powder

### Method:

Place oil and beans in a food processor. Blend until smooth. Pour into a bowl, then stir in cheese, salt and chilli powder. Cook on HIGH for 1 to 1½ minutes or until cheese melts. Stir well. Serve with corn chips.

## Spicy Nuts

Makes : 500 g

### Ingredients:

60 g butter or margarine  
15-30 g curry powder  
15 g Worcestershire sauce  
330 g mixed nuts

### Method:

Place butter in an oblong dish. Cook on HIGH for 1½ minutes until melted. Add remaining ingredients. Stir well to coat nuts.

Cook on HIGH for 5 to 6½ minutes.

# European Recipes

## Mushroom Soup

Serves : 4

### Ingredients:

15 g butter  
250 g mushrooms, sliced  
15 g flour  
500 ml chicken stock  
125 ml white wine  
5 g mustard  
125 ml cream

### Method:

Place butter and mushrooms in a 2-litre casserole dish. Cover and cook on HIGH for 5 minutes. Add flour, stock, wine, mustard and cream to mushrooms, and mix well. Cover and cook on HIGH for 6 to 8 minutes, stirring halfway through cooking.

**Tip:** This soup can be puréed if desired.



Roast Chicken

## Vegetable Soup

Serves : 4-6

### Ingredients:

500 g prepared vegetables of your choice (carrot, turnips, celery, etc), finely chopped  
1 onion, chopped  
30 g butter  
30 g cake flour  
875 ml chicken stock  
salt and pepper  
45 g parsley, chopped

### Method:

Place vegetables, except onion, in a 3-litre casserole dish. Cover and cook on HIGH for 8 to 10 minutes. Set aside. Place onion and butter in a large casserole dish and cook on HIGH for 2 to 3 minutes. Add flour to onion mixture and mix well.

Gradually add 250 ml of stock. Stir well. Cook on HIGH for 3 minutes, stirring halfway through cooking. Add remaining stock and vegetables. Cook on HIGH for 12 to 14 minutes. Season with salt and pepper. Serve sprinkled with chopped parsley.

## Cheese Sauce

Makes : 375 ml

### Ingredients:

30 g butter  
30 g flour  
310 ml milk  
salt and pepper  
75 g tasty cheese

### Method:

Melt butter in a 500 ml jug on HIGH for 1 minute. Add flour and mix well. Gradually stir in milk, salt and pepper. Cook on HIGH for 4 to 5 minutes, stirring halfway through cooking. Add cheese and cook on HIGH for a further 1 to 2 minutes. Stir and serve with the vegetable of your choice.

## Baked Custard

Serves : 4-5

### Ingredients:

425 ml milk  
3 large eggs, lightly beaten  
60 g sugar  
5 ml vanilla essence  
pinch ground nutmeg

### Method:

Place milk in a 1-litre glass jug. Cook on HIGH for 2 minutes. Add eggs, sugar and vanilla to milk, whisking all the time. Strain mixture into a 20-cm round dish and sprinkle with nutmeg. Cook on MEDIUM for 11 to 13 minutes. Allow to stand covered for 5 minutes before serving.

## Roast Chicken

Serves : 4 to 6

### Ingredients:

1.5 kg chicken  
15 g melted butter  
pepper

### Method:

Clean and pat chicken dry with paper towel. Brush chicken with melted butter and sprinkle with pepper. Place chicken breast-side down on a rack in a shallow dish.

Cook on MEDIUM-HIGH for 36 to 42 minutes, turning halfway through cooking. Stand for one third of cooking time, wrapped in foil before carving.

## Irish Stew

Serves : 8

### Ingredients:

750 g lamb, cut into 2 cm cubes  
2 carrots, peeled and sliced  
2 potatoes, peeled and sliced  
500 ml water  
40 g packet French Onion Soup mix  
1 bay leaf

### Method:

Arrange lamb, carrots and potatoes in a 2-litre casserole dish. Combine water, soup mix and bay leaf in a mixing bowl. Pour over meat, carrots and potatoes.

Cook on MEDIUM-HIGH for 6 to 8 minutes and then cook on MEDIUM for 50 to 60 minutes. Stand covered for 5 minutes. Serve with steamed vegetables.

# European Recipes



Roast Lamb

## Roast Lamb

Serves : 4 to 6

### Ingredients:

60 g apricot jam  
1.2 kg leg lamb

### Method:

Place lamb fat side down on a rack in a shallow dish. Brush with half the apricot jam.

Cook on MEDIUM-HIGH for 30 to 35 minutes. Turn halfway through cooking. Stand covered 10 minutes before carving.

## Italian Chicken Casserole

Serves : 4 to 6

### Ingredients:

15 ml oil  
1 clove garlic, crushed  
6 chicken pieces  
250 g baby onions  
425 g can tomatoes  
60 ml tomato paste  
2 g marjoram  
2 g oregano  
100 g button mushrooms  
20 g black olives  
30 g chopped parsley  
salt and pepper

### Method:

Preheat a browning dish on HIGH for 6 minutes. Add oil, garlic and chicken pieces to dish. Cook on HIGH for 4 minutes, turn and cook on HIGH for a further 4 minutes. Set aside. Place onion in a 3-litre casserole dish, cover and cook on HIGH for 4 minutes. Add chicken, tomatoes, tomato paste, marjoram and oregano to dish and cook on MEDIUM-HIGH for 10 minutes. Add remaining ingredients to dish and cook on MEDIUM-HIGH for a further 5 minutes. Serve with garden salad and crusty bread.

## Tarragon Chicken and Mushrooms

Serves : 6 to 8

### Ingredients:

1.5 kg chicken pieces  
1 onion, sliced  
2 g dried tarragon leaves  
salt and pepper  
150 g mushrooms, finely sliced  
440 ml can cream of mushroom soup  
125 ml sour cream

### Method:

#### To Cook by Microwave:

Place chicken and onion in a 4-litre casserole dish. Cook on MEDIUM-HIGH for 25 to 30 minutes. Drain away any excess fat. Season with tarragon, salt and pepper. Add mushrooms. Cook on MEDIUM-HIGH for 3 to 4 minutes. Blend together soup and sour cream. Spoon over chicken. Cook covered on MEDIUM-HIGH for 12 to 15 minutes. Remove chicken to a serving platter. Stir sauce and spoon over chicken. Serve with rice and vegetables.

## Mediterranean Curry

Serves : 4

### Ingredients:

15 ml oil  
1 large onion, chopped  
1 large tomato, chopped  
30 g curry powder  
15 g chilli powder  
1 kg chuck steak, fat removed and cut into  
2.5 cm cubes  
5 g salt  
125 ml water  
15 ml malt vinegar

### Method:

Place oil, onion and tomato in a large casserole dish and cook on HIGH for 4 to 5 minutes. Stir in curry powder, chilli powder and meat. Cook on HIGH for a further 5 minutes. Add remaining ingredients, ensuring the meat is covered by the liquid. Cook, uncovered, on HIGH for 5 minutes, then on MEDIUM for 1 to 1½ hours. Stir occasionally during cooking. Serve with rice.



Lamb Chops with Spicy Sauce

## Lamb Chops with Spicy Sauce

Serves : 4

### Ingredients:

#### Marinade:

45 g tomato paste  
30 ml vegetable oil  
30 ml lemon juice  
2 cloves garlic, crushed  
5 g chilli powder  
5 g coriander powder  
5 g ground ginger  
15 g finely chopped fresh parsley  
freshly ground black pepper to taste  
8 lamb chops (approx. 800 g)

### Method:

Combine all marinade ingredients to form a thick mixture. Place chops in a single layer in a shallow dish and pour marinade mixture over them. Allow to marinate for at least 6 to 8 hours in the refrigerator.

Remove chops from marinade (reserving this mixture) and place on a rack in a shallow dish. Cook on HIGH for 8 to 10 minutes, turning over halfway through cooking. Place marinade mixture into a jug and heat on HIGH for 30 to 40 seconds. Arrange chops on a serving platter, then pour the sauce over them. Serve garnished with parsley or watercress.

# European Recipes

English



*Fish Roll*

## Fish Roll

Serves : 4 to 6

### Ingredients:

170 g can crabmeat, drained  
2 large egg whites  
60 ml cream  
salt and pepper  
7 to 8 spinach leaves, stalks removed  
5 small, skinned and boned snapper fillets  
200 g sliced smoked salmon

### Sauce:

15 g butter  
15 g flour  
125 ml chicken stock  
125 ml cream  
15 g pink peppercorns, crushed  
pinch salt

### Method:

Place crabmeat into a bowl. Set aside. Beat egg whites until stiff peaks form. Beat cream in a separate bowl until thick. Add egg whites, cream, salt and pepper to crabmeat. Mix lightly. Set aside. Place spinach in a covered bowl and cook on HIGH for 1 to 2 minutes. Remove and drain. Lay a large sheet of plastic wrap on a flat surface. Lay fillets on wrap so they form a rectangle. Place spinach evenly on top of fish and then spoon crab mixture over. Place smoked salmon on top of crab mixture and roll on a plate and cook on MEDIUM for 6 to 8 minutes. Stand for 15 minutes. Remove wrap and slice.

### Sauce:

Melt butter in a 500 ml jug on HIGH for 30 seconds. Add flour, stir well. Add stock stirring continuously. Cook on HIGH for 2 to 3 minutes, stirring halfway through cooking. Add cream, peppercorns and salt. Stir well. Pour sauce over fish roll and serve with prawns and lemon wedges.

## Whole Stuffed Fish

Serves : 2

### Ingredients:

500 g whole fish, cleaned and scaled (Bream or Snapper)  
30 g melted butter

### Stuffing:

250 g fresh breadcrumbs  
4 spring onions, sliced  
5 g dried basil  
juice of ½ lemon  
30 g chopped parsley  
freshly ground black pepper

### Method:

Brush fish cavity with melted butter. Combine remaining butter with remaining ingredients to make stuffing. Stuff fish cavity with mixture and secure opening with wooden toothpicks.

Place fish in a shallow dish. Cover and cook on MEDIUM for 7 to 9 minutes. Stand covered for 5 minutes before serving.

## Smoked Haddock

Serves : 2 to 4

### Ingredients:

2 medium sized smoked haddock fillets (approx. 500 g)  
15 g butter, melted  
45 ml water or milk  
freshly ground black pepper

### Method:

Place all ingredients in a 3-litre casserole dish. Cover and cook on MEDIUM-HIGH for 6 to 8 minutes, or until cooked and fish flakes when tested with a fork.

## Scalloped Potatoes

Serves : 6 to 8

### Ingredients:

1 kg old potatoes, peeled and thinly sliced  
30 ml water  
300 ml sour cream  
60 ml milk  
salt and pepper  
paprika  
15 g snipped chives

### Method:

Place potatoes and water in a 3-litre casserole dish. Cover and cook on HIGH for 10 to 12 minutes. Drain. In a small bowl mix together sour cream, milk, salt and pepper. Pour over potatoes. Sprinkle with paprika and chives. Cook on HIGH for 4 to 5 minutes, until thoroughly heated. Serve hot.

## Seafood Marinara

Serves : 4

### Ingredients:

250 g scallops  
250 g prawns, shelled and deveined  
1 squid (approx. 275 g) cleaned and sliced  
30 g butter  
1 clove garlic, crushed  
2 tomatoes, peeled and chopped  
15 g tomato paste  
60 ml white wine  
5 g basil  
pepper  
chopped parsley

### Method:

Place cleaned seafood into a 2-litre casserole dish. Set aside. Place butter and garlic in a 1-litre casserole dish and cook on HIGH for 1 minute. Add remaining ingredients to dish, except seafood, and cook on HIGH for 5 minutes. Purée tomato mixture in a blender or food processor and pour over seafood. Cook on MEDIUM-HIGH for 5 to 7 minutes. Stand for 5 minutes. Serve with salad or pasta.

# European Recipes

## Ratatouille

Serves : 4

### Ingredients:

60 ml vegetable oil  
1 large onion, chopped  
2 cloves garlic, crushed  
2 g dried thyme  
1 small eggplant, cut in 2.5cm cubes  
1 large red pepper, deseeded and cubed  
1 small green pepper, deseeded and cubed  
2 courgettes, sliced  
3 large tomatoes, chopped  
6 to 8 small mushrooms, halved  
pepper to taste

### Method:

Place half the oil in a shallow dish with onion, garlic and herbs. Heat on HIGH for 2½ to 3 minutes. Spoon onion mixture into a deep dish, then add remaining oil to shallow dish. Add eggplant to oil and cook on HIGH for 1½ to 2 minutes. Spoon eggplant into a deep dish. Put peppers in a shallow dish and cook on HIGH for 2 to 3 minutes. Add peppers, plus remaining ingredients, to deep dish. Cook covered on HIGH for 5 minutes, then on MEDIUM-HIGH for 6 to 8 minutes. Stand for 5 minutes. Serve.

## Hollandaise Sauce

Makes : 190 ml

### Ingredients:

60 g butter  
30 ml lemon juice  
2 large egg yolks  
60 ml cream  
2 g mustard  
1 g salt

### Method:

Place butter in a 500 ml jug and cook on HIGH for 40 seconds. Add lemon juice, egg yolks and cream. Mix well. Cook on MEDIUM-HIGH for 60 to 90 seconds. Add mustard and salt. Mix until smooth. Serve with eggs, vegetables or fish dishes.

## Tomato Chutney

### Ingredients:

250 g onions, finely chopped  
1.5 kg ripe tomatoes, skins removed and tomatoes chopped  
5 g salt  
5 g paprika  
pinch cayenne pepper  
150 ml malt vinegar  
175 ml sugar

### Method:

Place onions in a 3-litre casserole dish. Cover and cook on HIGH for 4 to 5 minutes. Add tomatoes, cover and cook on HIGH for 5 to 6 minutes. Add salt, spices and vinegar. Stir well and cook on HIGH for 10 minutes, stirring once during cooking. Add sugar, stir well and cook on HIGH for 35 to 40 minutes, stirring occasionally. Pour into sterilised jars and seal.

## Spaghetti Meat Sauce

Serves : 4 to 6

### Ingredients:

500 g minced beef  
1 small onion, chopped  
1 clove garlic, crushed  
190 g finely sliced celery  
425 g can tomatoes, chopped  
250 g tomato paste  
2 beef stock cubes (or 10 g beef stock powder)  
30 g finely chopped parsley  
15 ml Worcestershire sauce  
5 g salt  
5 g brown sugar  
2 g pepper  
1 bay leaf

### Method:

In a 3-litre casserole dish combine minced beef, onion, garlic and celery. Cover and cook on MEDIUM-HIGH for 8 to 10 minutes. Drain off fat. Add remaining ingredients and mix well. Cover and cook on MEDIUM-HIGH for 25 to 30 minutes, stirring halfway through cooking. Serve with spaghetti.

## Lemon Butter

Makes : 250 g

### Ingredients:

grated rind and juice of 3 lemons  
85 g sugar  
3 large egg yolks  
15 g butter  
15 g cornflour

### Method:

Blend all ingredients in a 500 ml glass jug. Cook on MEDIUM-HIGH for 3 minutes, or until thickened, stirring every minute. Pour into hot sterilised jars and seal immediately.

## Orange Marmalade

### Ingredients:

700 g oranges  
1 lemon  
750 g sugar

### Method:

Wash fruit and cut in half. Squeeze juice from fruit and set aside. Remove rind from fruit, being careful not to include white pith. Cut rind into fine strips. Set aside. Pour fruit juice into a 1-litre jug. Add enough water to make 750 ml of liquid. Add seeds. Cover and cook on HIGH for 20 minutes. Strain. Add sugar and rind to mixture. Mix well. Cook on HIGH for a further 30 minutes, or until marmalade is setting. Pour into clean sterilised jars. Seal.

## Apricot Chutney

### Ingredients:

250 g dried apricots  
375 ml water  
5 g ground ginger  
190 ml white vinegar  
5 g chilli powder  
250 g sugar

### Method:

Combine apricots and water in a 2-litre casserole dish. Cook on HIGH for 8 to 10 minutes. Strain and purée apricots in a blender or food processor. Place remaining ingredients in a 2-litre casserole dish and cook on HIGH for 5 minutes. Add apricot purée and cook on MEDIUM-HIGH for 20 to 25 minutes. Cool and pour into sterilised jars. Serve with turkey or lamb.



Spaghetti Meat Sauce, Hollandaise Sauce

# Chinese Recipes

English



*Hammour Won Ton Soup*

## Stuffed Mushrooms with Shrimp Paste

Serves : 4

### Ingredients:

12 black Chinese mushrooms, small  
1 spring onion, chopped  
10 g ginger root, sliced  
400 g raw shrimps  
3 g salt  
1 egg white  
10 ml soy sauce  
30 g cornstarch  
2 g black pepper  
10 ml sesame oil  
30 ml cooking oil  
8 stalks Chinese broccoli  
100 ml fish stock  
20 g starch  
8 g green coriander leaves, chopped

### Method:

Soak mushrooms in water for 20 minutes. Drain and combine with spring onions and ginger in a 1-litre bowl. Cover with cling film and steam on HIGH for 20 minutes. De-vein the rinsed shrimps. Cut into pieces and keep aside. In another 1-litre bowl combine shrimps, salt, egg white, soy sauce, cornstarch, pepper and sesame oil. Mix well. Divide into 12 portions. Dip each mushroom in starch and fill with the paste. Lightly oil a flat platter, place mushrooms in a single layer and cook on HIGH for 6 minutes. Keep aside. Heat oil in a 1-litre bowl on HIGH for 2 minutes. Stir in broccoli, cover and cook on HIGH for 10 minutes. Arrange broccoli along with the mushrooms on the platter. Cook stock and starch with a dash of sesame oil in a small bowl for 2 minutes on HIGH. Pour over the broccoli and mushrooms and serve garnished with coriander leaves.

## Hammour Won Ton Soup

Serves : 4

### Ingredients:

400 g Hammour fish, ground  
20 g spring onions, chopped  
10 g cornstarch  
6 g salt  
10 ml sesame oil  
24 Won Ton skins  
1 litre stock or water  
3 g pepper  
400 g Bok Choy or baby green vegetables

### Method:

Combine Hammour, spring onions, cornstarch, salt, sesame oil and 20 ml of water. Fill Won Ton Skins with this mixture and fold. Keep aside. Pour stock into a 2-litre bowl. Add pepper and cook on HIGH for 8 minutes. Add Won Tons to the soup. Cover and cook on HIGH for another 8 minutes. Set aside. Cook Bok Choy in salty water in a 1-litre bowl on HIGH for 5 minutes. Drain and add to the soup. Serve hot.



*Chicken in Paper Packs*

## Chicken in Paper Packs

Serves : 4

### Ingredients:

300 g fresh chicken, boneless  
6 Chinese mushrooms  
2 g salt  
15 ml light soy sauce  
5 g sugar  
2 g pepper  
5 ml sesame oil  
5 ml wine  
10 ml oil  
20 g green onions, chopped  
10 g parsley, chopped  
10 g carrots, shredded  
1 large sheet glass paper

### Method:

Cut chicken into thin slices. Soak mushrooms for 30 minutes or until soft. Cut into thin slices. Combine together chicken, mushrooms, salt, light soy sauce, sugar, pepper, sesame oil, wine and oil. Keep aside. Cut glass paper into small pieces. Fill each piece with green onions, parsley, carrots and the mushroom-chicken mixture. Fold into small packs. Place these packs onto a platter and cook on HIGH for 3 to 4 minutes. Serve hot.

# Chinese Recipes

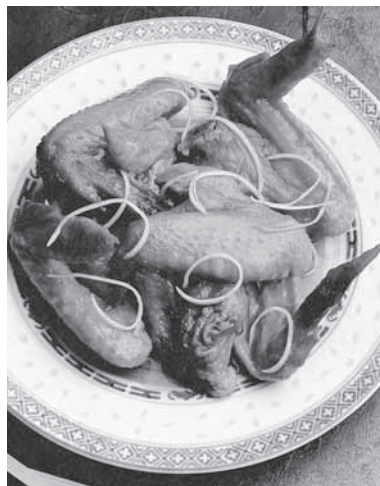

Chicken Wings in Lemon Sauce

## Chicken Wings in Lemon Sauce

Serves : 4-6

### Ingredients:

1 kg chicken wings  
60 ml soy sauce  
60 ml water  
5 g ginger powder  
2 cloves garlic, crushed  
60 ml lemon juice

### Method:

Place chicken wings in a 3-litre casserole dish. Mix together remaining ingredients and pour on chicken wings. Keep the marinated chicken in the refrigerator for 45 minutes. Cook, covered on MEDIUM-HIGH for 20 to 25 minutes, or until chicken is tender. Serve hot with rice.

## Szechuan Lamb

Serves : 4

### Ingredients:

500 g lamb meat, shredded  
20 ml oil  
½ dried chilli pepper, crushed  
40 ml soy sauce  
100 ml stock  
20 g cornstarch  
3 sticks celery, shredded  
1 medium sized sweet red pepper, shredded

### Method:

Combine meat and oil and divide into 3 portions. Take 1 portion at a time, place in a 2-litre casserole dish and cook covered on HIGH for 5-6 minutes each. Mix together all three. Add crushed chilli pepper. Keep aside. Mix the soy sauce and stock, and gradually stir into the cornstarch. Pour over the meat and cook on MEDIUM-HIGH for 4 to 5 minutes. Add celery and red pepper, and mix well. Cook for another 1 minute on HIGH until sauce thickens and the vegetables still remaining crisp.

## Stir-Fried Rice

Serves : 4

### Ingredients:

15 ml vegetable oil  
1 clove garlic, crushed  
1 cm piece root ginger, finely chopped  
1 small carrot, finely chopped  
1 stick celery, sliced  
½ green or red pepper, cut into strips  
6-8 medium-sized mushrooms, sliced  
3 spring onions, chopped  
2 eggs  
15-30 ml soy sauce  
500 g cooked rice

### Method:

Place oil, garlic and ginger in a large shallow dish and cook on HIGH for 2½ minutes. Keep aside. Add the carrot, celery and pepper. Cook for 3 minutes on HIGH. Break eggs into a small dish, add salt and pepper to taste, mix well and cook on HIGH for 2 minutes. Slice the cooked egg into thin strips. Add these strips, soy sauce and cooked rice to the vegetable mixture, stir well and cook on HIGH for 4 minutes. Serve hot.

**Note:** 250 g uncooked rice will yield about 500 g of cooked rice.



Chinese Beef and Vegetables

## Chinese Beef and Vegetables

Serves : 4-6

### Ingredients:

500 g rump steak  
5 g root ginger, grated  
1 clove garlic, crushed  
15 ml oil  
125 ml beef stock  
15 ml soy sauce  
30 ml Hoi Sin sauce  
10 g cornflour  
375 g frozen vegetables (egbroccoli, mushrooms, onions, cauliflower, snow peas, pepper chunks, etc.)

### Method:

Cut beef into paper thin strips. Place ginger, garlic and oil in a casserole dish. Cook on HIGH for 1 minute. Keep aside. Combine stock, soy sauce, Hoi Sin sauce and cornflour. Add to ginger-garlic mixture. Cook on HIGH for 2 minutes. Add vegetables and cook covered on HIGH for 5 minutes. Mix well. Add meat strips and cook on HIGH for 8 minutes, stirring midway. Stand covered for 3 minutes before serving with boiled rice.

# Indian/Pakistani Recipes

## Upma (Semolina Snack)

Serves : 4

### Ingredients:

250 g mixed frozen vegetables, diced and thawed  
200 g semolina  
100 ml oil  
5 g mustard seeds  
5 g washed split urad dal (lentils)  
2 red chillies, whole  
12 curry leaves  
20 ml cold water  
800 ml hot boiling water  
10 g salt

### Method:

Place semolina in a 1-litre casserole dish and brown on HIGH for 5 minutes, stirring frequently. Set aside. Heat oil in a 2-litre dish and cook on HIGH for 2 minutes. Add mustard seeds, lentils, red chillies and curry leaves and cook on HIGH for 2 minutes. Add vegetables and 20 ml cold water. Mix well. Cover and cook on HIGH for 5 minutes. Add boiling water and salt. Add semolina and mix well. Cook on HIGH for 4 minutes, stirring frequently. Serve hot with coconut chutney.

## Vegetable Pulao (Vegetable Rice)

Serves : 4

### Ingredients:

350 g rice  
400 g frozen mixed vegetables, thawed  
60 ml oil  
100 g onions, sliced  
10 g ginger, chopped  
1 clove garlic, chopped  
10 g cumin seeds, roasted  
4 green cardamoms, crushed  
8 cloves  
8 black peppercorns  
5 g cinnamon sticks  
6 bay leaves  
6 g salt  
700 ml hot boiling water  
1 black cardamom, crushed

### Method:

Clean, wash and soak rice in double the quantity of water for 1 hour. Heat oil in a 3-litre casserole dish on HIGH for 1 minute. Add onions and brown on HIGH for 8 minutes, stirring frequently. Remove onions from the oil and keep aside. Reheat the oil on HIGH for 1 minute. Add ginger, garlic, cumin seeds, green cardamoms, cloves, peppercorns, cinnamon sticks and bay leaves. Mix well and cook on HIGH for 1 minute. Add vegetables, cover and cook on HIGH for 5 minutes, stirring midway. Drain rice and add to the vegetables. Add hot water and salt. Mix well and cook covered on HIGH for 10 minutes. Stir, and cook on MEDIUM-HIGH for 15 minutes. Serve hot sprinkled with black cardamom powder and garnished with the fried onions.

## Masale Wali Gobhi (Spicy Cauliflower)

Serves : 4

### Ingredients:

700 g whole cauliflower  
40 ml hot boiling water  
50 ml oil  
5 g coriander leaves, chopped

### Marinade:

100 g yoghurt  
100 g tomato purée  
10 g ginger, crushed  
1 big clove garlic, crushed  
1 green chilli, crushed  
3 g red paprika powder  
3 g garam masala  
2 g turmeric powder  
5 g coriander powder  
5 g cumin seed powder  
10 g salt

### Method:

Trim the cauliflower, removing the stalk and leaves. Wash well. Pour the hot water in a 2-litre casserole dish. Stir in turmeric powder and salt. Place the cauliflower in the dish, cover and cook on HIGH for 10 minutes. Keep aside. Pour 10 ml oil in a 1-litre casserole dish and heat on HIGH for 2 minutes. Combine all the rest of the marinade ingredients and add to the oil. Stir and cook on MEDIUM-HIGH for 3 minutes. Pour marinade over the cauliflower ensuring it is covered well. Set aside for 4 hours. Heat oil in a small bowl on HIGH for 2 minutes. Pour it over the cauliflower. Cook on MEDIUM-HIGH for 15 minutes, turning it over after 8 minutes. Serve hot, garnished with coriander leaves.



Upma

# Indian/Pakistani Recipes

## Sukhe Alu (Spicy Potatoes)

Serves : 4

### Ingredients:

500 g potatoes  
10 g coriander powder  
10 g cumin seed powder  
3 g red chilli powder  
5 g garam masala  
10 g mango powder  
2 g dried ginger powder  
5 g dried mint powder  
10 g salt  
30 ml oil  
3 g cumin seeds, roasted  
5 g coriander leaves, chopped

### Method:

Wash and dry the potatoes. Prick lightly with a fork and place in a dish lined with a paper towel. Cook on HIGH for 8-9 minutes. Cool and cut into small pieces. Combine all the dry spices and sprinkle on the potato pieces. Mix well. Keep aside. Place oil in a 1-litre casserole dish, cover and heat on HIGH for 2 minutes. Add cumin seeds and potatoes, and cook on HIGH for 3 minutes. Mix well. Serve hot, garnished with coriander leaves.



Masoor Dal, Sukhe Alu, Bhari Hui Bhindi

## Masoor Dal (Lentils)

Serves : 4

### Ingredients:

200 g Masoor Dal (Lentil)  
800 ml hot boiling water  
10 g salt  
3 g turmeric powder  
20 g ghee  
80 g onions, finely chopped  
10 g ginger, finely chopped  
1 clove garlic, finely chopped  
1 green chilli, finely chopped  
5 g cumin seeds  
1 pinch asafoetida powder  
3 g red chilli powder  
3 g garam masala  
5 g coriander leaves, chopped

### Method:

Wash and soak lentils for 4 hours. Drain and place in a 3-litre bowl along with hot water, salt and turmeric powder. Mix well, cover and cook on HIGH for 20 minutes. Stir, cover and cook on MEDIUM-HIGH for another 10 minutes. Set aside. Place ghee, chopped onions, ginger and garlic in a small bowl. Cover and cook on HIGH for 3 minutes, stirring midway. Add cumin seeds, asafoetida powder and red chilli powder, and mix well. Cook on HIGH for 1 minute. Add to the cooked lentils and mix well. Cook on HIGH for 1 minute. Serve hot, sprinkled with garam masala and garnished with coriander leaves.

## Bhari Hui Bhindi (Stuffed Okra)

Serves : 4

### Ingredients:

500 g okra  
30 g coriander powder  
30 g cumin seed powder  
15 g dried mango powder  
5 g red chilli powder  
5 g turmeric powder  
5 g garam masala  
10 g salt  
50 ml oil  
10 g coriander leaves, chopped

### Method:

Wash and dry the okra. Cut off the heads and a small portion of the tails and slit each down the middle ensuring that it doesn't split into 2 halves. Keep aside. Combine all the dry spices in a small bowl and cook on HIGH for 2 minutes, stirring after every 30 seconds. Stuff this mixture into the slits in the okra. Place the okra in a 2-litre shallow casserole dish. Heat oil in a small bowl on HIGH for 2 minutes and pour it on the okra. Cover the casserole and cook okra on HIGH for 10 minutes. Remove the lid and cook uncovered on HIGH for 6 minutes till it becomes dark green and almost crisp. Serve hot, garnished with coriander leaves.

# Indian/Pakistani Recipes

## Chicken Korma (Chicken Curry)

Serves : 4

### Ingredients:

700 g chicken cut into medium-sized pieces  
100 ml oil  
150 g onions, sliced  
100 g onions, grated  
10 g cashew nuts, chopped (optional)  
4 cloves  
5 g cinnamon sticks  
4 green cardamoms  
10 g ginger, crushed  
1 clove garlic, crushed  
10 g poppy seeds, crushed (optional)  
3 g turmeric powder  
5 g cumin seed powder, roasted  
5 g coriander leaves, chopped  
5 g cashew nuts, chopped (for garnish)

### Marinade:

250 g yoghurt  
10 g ginger  
2 cloves garlic  
1 green chilli  
3 g red paprika  
5 g coriander powder  
5 g garam masala  
15 g salt

### Method:

Clean, trim, wash the chicken pieces. Pat dry. Combine marinade ingredients and add to the chicken. Set aside for 4 hours. Heat oil in a 2-litre bowl on HIGH for 2 minutes. Add sliced onions and brown on HIGH for 7 minutes, stirring occasionally. Remove the onions from the oil, mix with cashew nuts and grind into a fine paste. Reheat the oil on HIGH for 1 minute. Add cloves, cinnamon sticks and cardamoms and stand for 30 seconds. Add ginger, garlic, grated onions, poppy seeds and turmeric powder, and mix well. Cook on HIGH for 5 minutes, stirring occasionally. Add marinated chicken and the onion-cashew nut paste. Mix well. Cook, covered on HIGH for 20 minutes, stirring frequently. Serve hot, sprinkled with cumin seed powder and garnished with coriander leaves and cashew nuts.



Chicken Korma

## Hari Machhi (Coriander Fish)

Serves : 4

### Ingredients:

750 g fish  
20 ml lemon juice  
20 g salt

### Marinade:

150 g yoghurt  
100 g coriander leaves, crushed  
3 big cloves garlic, crushed  
6 green chillies, crushed  
40 ml oil

### Method:

Wash and cut the fish into medium-sized pieces. Prick all over with a fork. Mix half the lemon juice and salt, and pour on the fish. Keep aside for 15 minutes and then drain off excess liquid. Combine yoghurt, coriander leaves, garlic, green chillies, salt and the rest of the lemon juice, and stir well. Marinade the fish with this mixture, add oil and keep aside for 3 hours.

Remove the fish pieces. Pour the marinade into a 2-litre casserole dish and cook on HIGH for 10 minutes or until the gravy thickens, stirring midway. Add the fish pieces and cook on HIGH for 6 minutes, stirring occasionally. Serve hot with rice or chapattis.

## Makhni Gravy (Butter Gravy)

Serves : 6

### Ingredients:

1 kg Chicken/Paneer/  
Vegetables  
30 g butter  
10 g ginger, crushed  
1 clove garlic, crushed  
80 g onion, grated  
100 g tomato purée  
10 g red paprika powder  
10 g salt  
200 ml fresh cream  
200 ml fresh milk  
200 g yoghurt  
5 g garam masala  
5 g coriander leaves, chopped

### Method:

Place butter in a 2-litre casserole dish. Add onion-ginger-garlic paste and cook on HIGH for 4-5 minutes, stirring frequently. Add tomato purée and red paprika powder. Mix well and cook on HIGH for 3 minutes, stirring halfway. Add salt, cream, milk and yoghurt, and mix well. Cook on HIGH for 5 minutes. Add chicken, paneer or vegetables and cook till done. Serve hot, sprinkled with garam masala and garnished with coriander leaves.

# Indian/Pakistani Recipes

## Mutton Curry

Serves : 4

### Ingredients:

500 g mutton  
10 g coriander seeds  
10 g cumin seeds  
10 g poppy seeds  
8 almonds  
6 peppercorns  
2 cloves  
1 black cardamom  
5 g cinnamon sticks  
2 bay leaves  
10 g ginger, crushed  
2 big cloves garlic, crushed  
1 green chilli, crushed  
100 ml oil  
3 green cardamoms  
125 g onions, grated  
15 g salt  
3 g red paprika powder  
5 g turmeric powder  
30 g tomato purée  
100 g yoghurt  
5 g garam masala  
5 g coriander leaves, chopped

### Method:

Clean, trim and wash the meat pieces. Combine coriander seeds, cumin seeds, poppy seeds, almonds, peppercorns, cloves, black cardamom, cinnamon sticks and bay leaves in a small bowl, and cook on HIGH for 2 minutes. Remove from the oven. Add a little water, ginger, garlic and green chillies, and grind to a fine paste. Set aside. Place oil in a 2-litre bowl and heat on HIGH for 2 minutes. Add green cardamoms and grated onions. Brown on HIGH for 10 minutes, stirring frequently. Add salt, paprika, turmeric powder and the spices paste. Mix well and cook on HIGH for 1 minute. Add tomato purée and yoghurt. Mix well. Cook on HIGH for 3 minutes. Add meat pieces and mix well. Cook, covered on HIGH for 20 minutes or until light brown. Add water, stir and cook covered on MEDIUM-HIGH for 20 minutes or until tender. Serve hot, garnished with coriander leaves and garam masala.

## Sujji Ka Halwa (Semolina pudding)

Serves : 4

### Ingredients:

100 g sugar  
400 ml hot boiling water  
25 g ghee  
100 g semolina  
3 green cardamoms, crushed  
10 g almonds, chopped  
10 g raisins

### Method:

Combine sugar and water in a 1-litre bowl and cook on HIGH for 3 minutes, stirring midway. Heat ghee in a 2-litre casserole dish on HIGH for 1 minute. Add semolina and mix well. Cook on HIGH for 7 minutes, stirring after every minute. Add sugar syrup and mix well. Cook on HIGH for 6 minutes, stirring after every minute. Serve hot, garnished with raisins, chopped almonds and cardamom powder.

## Gajjar Ka Halwa (Carrot Pudding)

Serves : 6

### Ingredients:

500 g carrots  
1 litre milk  
20 g ghee  
40 g sugar  
10 g raisins  
4 green cardamoms, crushed  
10 g almonds, chopped  
10 g pistachios, chopped

### Method:

Wash, peel and grate carrots. Combine carrots and milk in a 3-litre bowl and cook on HIGH for 45 minutes, stirring frequently. Add ghee, sugar, raisins and cardamoms, and mix well. Cook on MEDIUM-HIGH for 30 minutes or till the milk evaporates. Serve either hot or cold, garnished with chopped almonds and pistachios.

English



Gajjar Ka Halwa

# Arabic Recipes

English

## Kima Soup

Serves : 10

### Ingredients:

25 g rice  
60 g minced lamb meat  
5 g salt  
3 g pepper  
25 g butter  
10 g onion  
300 ml lamb stock or 2 cubes  
of stock  
1 g Gum Mastic (optional)  
1 g cinnamon powder  
6 g parsley

### Method:

Soak rice in hot water for 15 minutes. Drain and keep aside. Mix minced lamb meat with salt and pepper, and shape into small balls. Cook on a platter on HIGH for 2 minutes. Keep aside. Place butter in a 2-litre casserole dish and add onions. Cook covered on HIGH for 3 minutes. Add lamb stock or cubes and water with the Gum Mastic. Cook on HIGH for another 5 minutes. Add rice, stir and cook on HIGH for 5 minutes. Add mince balls and cook on HIGH for another 10 minutes. Serve hot, sprinkled with cinnamon powder and garnished with parsley.

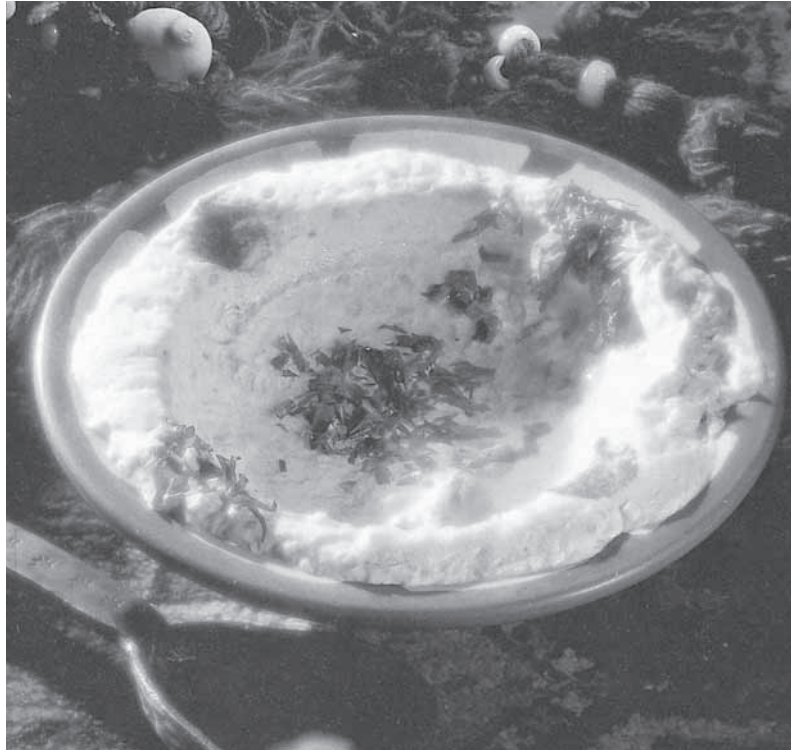

Mutable

## Stuffed Baby Marrow With Tomatoes

Serves : 10

### Ingredients:

250 g rice  
2.5 kg baby marrow  
500 g minced lamb meat  
25 g butter  
10 g salt  
6 g pepper  
30 ml water  
200 g onions, chopped  
4 cloves garlic, chopped  
20 ml oil  
1 kg tomatoes, sliced  
5 g cinnamon powder  
200 ml hot water

### Method:

Clean, wash and soak rice for 30 minutes. Drain. Clean and wash marrow. Make a small hole on top and scoop out the flesh from inside. Wash again and keep aside. Combine rice, minced lamb, butter, salt, pepper and water. Stuff two-thirds the length of the marrow with this mixture. In a shallow casserole dish, mix onions, garlic and oil, and cook on HIGH for 3 minutes. Evenly spread tomatoes on this mixture. Place stuffed marrows on top and press down firmly. Cover with hot water. Cook covered on HIGH for 20 minutes. Serve hot sprinkled with cinnamon powder.

## Mutabel

Serves : 10

### Ingredients:

250 g whole eggplant  
200 ml olive oil  
40 g tahina  
4 cloves garlic  
150 ml lemon juice  
10 g salt  
10 ml olive oil (for garnish)  
10 g parsley, chopped  
20 g pomegranate seeds, fresh

### Method:

Lightly pierce the eggplant with a fork. Place on a paper towel in a 1-litre casserole dish and cook on HIGH for 10 minutes. Cool, immerse in water and remove the skin. Mash the eggplant and combine with olive oil, tahina, garlic, lemon juice, and salt. Serve garnished with olive oil, parsley and fresh pomegranate seeds.

# Arabic Recipes

## Kibbeh Bil Leban

Serves : 10

### Ingredients:

400 g crushed wheat  
500 g minced lamb meat  
100 g onions, finely chopped  
20 g salt  
10 g pepper  
80 ml oil  
200 g lamb, roughly ground  
1 litre yoghurt  
80 ml water  
100 g cornflour  
200 g mint, chopped  
100 g garlic, chopped  
100 g pine nuts

### Method:

Clean, wash and soak crushed wheat in water for 1 hour. Drain. Combine with minced lamb, finely chopped onions, salt and pepper, and grind well. Shape into small balls and keep aside. Heat 40 ml of oil in a 1-litre bowl on HIGH for 2 minutes. Add roughly ground lamb, mix and cook covered on HIGH for 10 minutes. Stuff this mixture into the centre of the minced balls. Cook the stuffed balls (kibbeh) in a covered casserole on HIGH for 4 minutes. Keep aside. Mix yoghurt and water separately in a 2-litre bowl, and heat on HIGH for 3 minutes. Mix cornflour with a little water to make a fine paste. Add this to the yoghurt and mix well. Cook further on HIGH for 3 minutes. Separately combine 40 ml of oil, mint and garlic in a small bowl, and cook on HIGH for 3 minutes. Add to the yoghurt and mix well. Add the kibbeh to the mixture and heat on HIGH for 2 minutes. Sprinkle with pine nuts and serve hot with vermicelli or rice.

## Tajen Khudar Mushakal

Serves : 10

### Ingredients:

150 ml corn oil  
500 g eggplant, peeled and cubed  
500 g potatoes, peeled and cubed  
500 g marrow, peeled and cubed  
300 g green peppers, sliced  
150 ml olive oil  
175 g onions, finely chopped  
40 g garlic, finely chopped  
500 g tomatoes  
20 g salt  
10 g pepper  
30 ml water  
10 g white pepper

### Method:

Heat corn oil in a covered 3-litre casserole dish on HIGH for 3 minutes. Add eggplant, potatoes, marrow and green peppers, and mix well. Cook further on HIGH for 6 minutes, stirring midway. Remove the vegetables from the oil and keep aside. In another 2-litre casserole dish combine olive oil and onions, and brown on HIGH for 3 minutes. Add vegetables, tomatoes, salt, pepper and water, and cook covered on HIGH for 10 minutes. Serve hot, sprinkled with white pepper.

## Stuffed Vine Leaves

Serves : 10

### Ingredients:

300 g rice  
2 big onions chopped  
100 g parsley, finely chopped  
1 tsp dried mint, finely chopped  
500 g tomatoes, finely chopped  
150 ml olive oil  
300 ml lemon  
20 g salt  
3 g pepper  
500 g potatoes, peeled & sliced  
1 kg vine leaves

### Method:

Clean, wash and soak the rice for 30 minutes. Drain. Add parsley, mint, tomatoes, and half the portion of oil, lemon juice, salt and pepper, and mix well. Set aside. Arrange the tomatoes and potato slices on the base of a very shallow casserole dish. Wash the vine leaves in hot water. Stuff them with the rice mixture. Place them on the potato and tomato base. Cover with water and add the rest of the lemon juice, oil, salt and pepper. Weigh down the leaves with a plate and cook covered on HIGH for 20 minutes. Serve cold.

English



Stuffed Vine Leaves

# Arabic Recipes

English

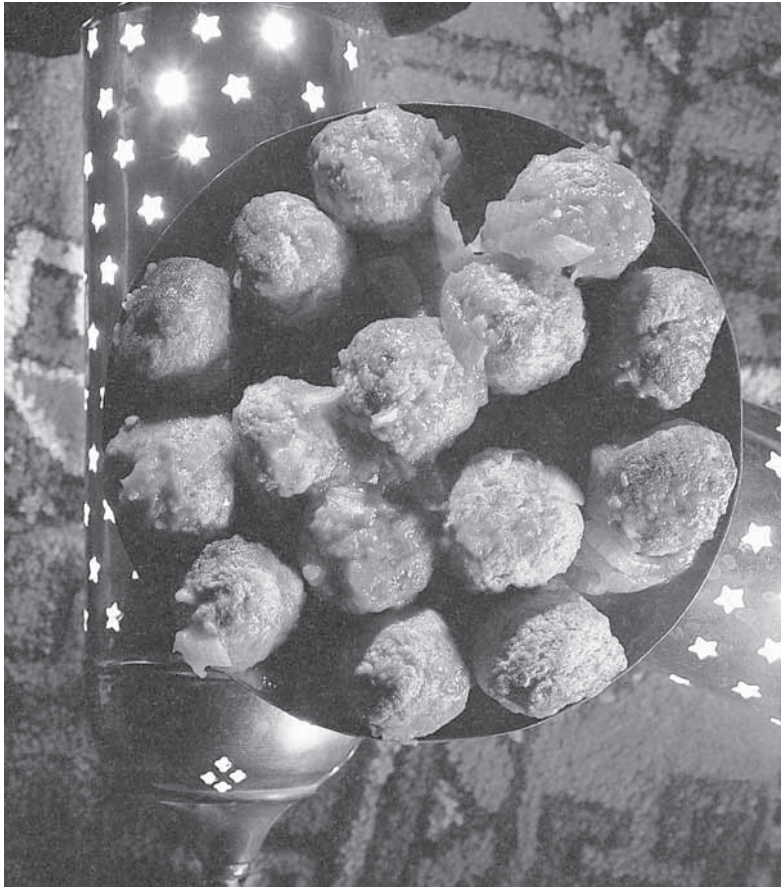

Daod Basha

## Daod Basha

Serves : 6

### Ingredients:

500 g minced lamb meat  
a pinch cinnamon  
20 g salt  
2 g bahrat al tahi (mixed spices)  
200 ml oil  
500 g onions, sliced  
75 g tomato purée  
½ litre water  
60 g pine nuts

### Method:

Combine minced lamb meat, cinnamon powder, 10 g salt and bahrat al tahi. Mix well and form into small balls. Place them in a shallow dish and cook on HIGH for 2 minutes. Set aside. Heat oil in a 2-litre covered casserole dish on HIGH for 2 minutes. Add onions and brown on HIGH for 6 minutes. Add tomato purée and water, and mix well. Cook covered on HIGH for 6 minutes. Add the meat balls and balance salt to the sauce, and cook further on HIGH for another 8 minutes. Serve hot, sprinkled with lemon juice and garnished with pine nuts.

## Kafta Bit Tahina

Serves : 10

### Ingredients:

1.5 kg minced lamb meat  
100 g onions, chopped  
150 g parsley, chopped  
6 g salt  
6 g pepper  
5 g cinnamon powder  
500 g tahina  
400 ml lemon juice  
150 ml water

### Method:

Combine minced lamb meat with onions, parsley, salt, pepper and cinnamon powder. Mix well and shape into small patties (Kaftas). Place Kaftas in a 2-litre casserole dish and cook covered on HIGH for 10 minutes. Keep aside. Mix tahina, lemon juice, water and a little salt to make tarator. Cook the tarator in a small bowl on HIGH for 8 minutes. Pour this over the kaftas and cook on MEDIUM-HIGH for 8 minutes. Garnish with pine nuts. Serve hot with vermicelli or rice.

## Chicken Musakhan

Serves : 10

### Ingredients:

2.5 kg chicken, each chicken cut into 4 pieces  
200 ml olive oil  
500 g onions, chopped  
20 g salt  
10 g pepper  
100 g semac  
100 g almonds, chopped  
200 ml water

### Method:

Place chicken in a 3-litre casserole dish, cover with water and cook covered on HIGH for 10 minutes. Drain and keep aside. Mix olive oil, onions, salt and pepper in a small bowl, and cook on HIGH for 3 minutes. Add semac, stir and cook on HIGH for another 2 minutes. Add the onion and spice mixture to chicken pieces, mix well and cook on HIGH for 20 minutes, stirring frequently. Garnish with almonds. Serve hot with rice/Arabic bread.

# Arabic Recipes

## Fish Sayodiya

Serves : 10

### Ingredients:

2.5 kg hamour fish  
200 ml olive oil  
1 kg onions, chopped  
5 g cumin seed powder  
25 g salt  
2.5 litre water  
800 g American rice  
100 g cornflour  
100 g pine nuts

### Method:

Clean, wash and cut fish into large pieces. Heat oil in a 3-litre covered casserole dish on HIGH for 2 minutes. Add fish and cook further on HIGH for 8 minutes. Remove fish from the oil and keep aside. Add onions to the same oil. Brown on HIGH for 8 minutes. Arrange the fish in another 2-litre casserole dish. Pour the olive oil and onions mixture on the fish. Add cumin powder, salt and water, and cook covered on HIGH for 4 minutes. Take out the fish again and strain the water left behind in the dish. Divide it into 2 equal portions. Pour one half into a 2-litre bowl, add rice and cook till done. To make the sauce mix the rest with cornflour and cook on HIGH for 2 minutes till thick. Serve the fish on a bed of rice. Garnish with pine nuts and serve the sauce separately.

## Samke Hara (Hot Fish)

Serves : 10

### Ingredients:

2 kg hamour fish, filleted  
600 g tahina  
200 ml lemon juice  
300 ml water  
100 g olive oil  
50 g onions, chopped  
50 g green peppers, chopped  
50 g red peppers, chopped  
500 g coriander leaves, chopped  
50 g green chillies, chopped  
25 cloves garlic, chopped  
20 g salt  
60 g pine nuts, fried

### Method:

Place fish fillets in a 2-litre casserole, cover with water and cook on HIGH for 3 minutes. Drain and keep aside. Combine tahina with lemon juice and water to make tarator. Heat oil in a 1-litre bowl on HIGH for 2 minutes. Add onions, green and red peppers, coriander leaves, green chillies, garlic and salt and cook covered on HIGH for 4 minutes. Add tarator, mix well and cook on HIGH for another 8 minutes. Spread this vegetable sauce on the fish and cook on HIGH for 7 minutes. Cool. Serve sprinkled with pine nuts.

## Muhlabbia

Serves : 8

### Ingredients:

50 g rice powder  
10 ml water  
1 litre milk  
200 g sugar  
15 ml rose water  
3 g miski  
20 g pistachios

### Method:

Make a fine paste with rice powder and water. Set aside. Pour milk in a 2-litre bowl and cook on HIGH for 3 minutes. Add sugar and stir well. Add the rice powder paste, mix well and cook on HIGH for 10-12 minutes, stirring frequently. Serve cold, sprinkled with rose water, powder miski and garnished with golden pistachios.

English



Muhlabbia

# Persian Recipes

## Nano Dok (Spice Mix)

### Ingredients:

15 - 45 g ghee  
5 g turmeric powder  
8 g dried mint

### Method:

Heat ghee in a small bowl on HIGH for 2 minutes. Stir in turmeric powder and cook for 10 seconds until turmeric colours a golden brown. Crush mint, add to the dish and stir. Let it stand for 5 minutes.

## Borani Esfanaj (Spinach Salad)

Serves : 6

### Ingredients:

750 g spinach  
60 g onions, finely chopped  
15 ml oil  
2 cloves garlic, crushed  
10 g salt  
3 g freshly ground black pepper  
450 g yoghurt  
Nano Dok for garnish

### Method:

Trim off roots and coarse stalks from the spinach. Wash leaves well, discarding any discoloured and damaged ones. Drain and shred coarsely. In a large casserole dish, heat oil on HIGH for 3 minutes. Add onions to the oil and cook on HIGH for 3 minutes. Add spinach and cook on HIGH for 4 minutes. Remove from the oven and add garlic, salt, and pepper. Cool. Place yoghurt in a mixing bowl and add spinach mixture. Toss well and adjust seasoning. Serve at room temperature, garnished with Nano Dok.

## Torshi Bademjan (Eggplant Pickle)

Serves : 6

### Ingredients:

1 kg eggplants (aubergines)  
(3-4 medium-sized)  
450 ml cider vinegar  
medium-sized piece tamarind  
115 ml hot water  
15 g white mustard seeds  
15 g coriander seeds, toasted  
10 g fennel seeds  
4-5 cloves garlic  
5 g ginger, chopped  
3 g chilli powder  
10 g freshly ground black pepper  
10 g salt

### Method:

Pierce eggplants with a fork, wrap in paper towels and place in a casserole dish. Cook on HIGH for 10 minutes or until soft. Hold onto the stem and peel skin from eggplants, then remove stems. Mash flesh and mix in ½ cup vinegar to prevent eggplant discolouring. Keep aside. Soak tamarind in hot water for 10-15 minutes until softened. Rub with fingertips to separate pulp, then press through a sieve and add to the eggplants. Combine another ½ cup vinegar, mustard seeds, coriander seeds, fennel seeds, peeled garlic cloves and ginger, and blend to a smooth paste. Add paste to eggplants with chilli powder, pepper, salt and remaining vinegar, and ladle into sterilised jars. Seal and store in a cool place.

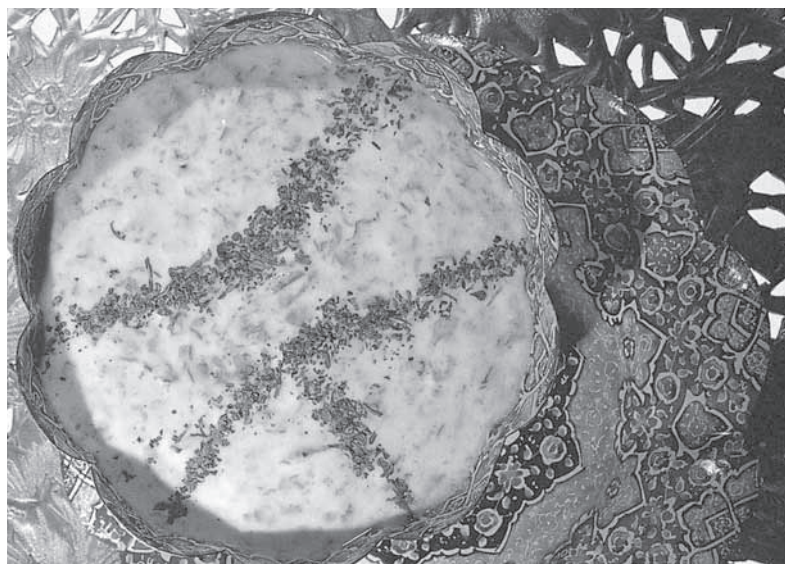

*Borani Esfanaj*

# Persian Recipes

## Eshkaneh (Onion Soup)

Serves : 5-6

### Ingredients:

300 g onions, sliced thinly  
75 g ghee  
75 g plain flour  
115 g finely chopped walnuts  
3 g turmeric powder  
1.2 litre water  
115 ml lemon juice  
115 g brown sugar  
10 g salt  
3 g freshly ground black pepper  
2 eggs  
Nano Dok for garnish

### Method:

Heat a little ghee in a casserole dish on HIGH for 2 minutes. Add half of onion slices and cook on HIGH for 8 minutes until brown. Remove and keep aside for garnishing. Take remaining ghee along with the rest of the onions. Cook on HIGH for 4 minutes. Stir in flour and cook on HIGH for 3 minutes until flour is golden. Add walnuts and turmeric powder, and stir. Cook on HIGH for 15 seconds. Stir in water and cook on HIGH for 6 minutes until thickened and bubbling, stirring after every 2 minutes. Cover and simmer on MEDIUM for 10 minutes. Add lemon juice, sugar, salt and pepper to taste. Cover and simmer on MEDIUM for 2 minutes. Beat the eggs lightly and pour into the dish slowly, stirring gently until eggs set in shreds. Garnish with reserved browned onions and Nano Dok.



*Kukuye Sibzamini*

## Khoreshe Alu (Prune and Meat Sauce)

Serves : 4-5

### Ingredients:

750 g boneless lamb or beef  
60 g onions, chopped  
15 g ghee or oil  
3 g turmeric powder  
pinch cinnamon powder  
340 ml water  
10 g salt  
3 g freshly ground black pepper  
225 g prunes  
10 ml lemon juice  
15 g brown sugar

### Method:

Trim meat and cut into 2 cm ( $\frac{3}{4}$  inch) cubes. Keep aside. Combine onions and oil in a casserole dish and cook covered on HIGH for 3 minutes. Add meat, turmeric powder and cinnamon. Cook on HIGH for 6 minutes, stirring after every 2 minutes. Add water, salt and pepper. Cover and cook on MEDIUM-HIGH for 20 minutes. Rinse prunes if necessary and add to meat with lemon juice and sugar. Cook on MEDIUM-HIGH for 20 minutes till meat is tender. Serve hot with chelou.

## Kukuye Sibzamini (Potato Omelet)

Serves : 4-6

### Ingredients:

500 g potatoes  
120 g onions, grated  
5 g turmeric powder  
10 g salt  
3 g freshly ground black pepper  
6 eggs  
60 g ghee

### Method:

Place potatoes in a deep casserole dish and cook on HIGH for 10 minutes. Remove skins and mash well. Blend in onions, turmeric powder, salt and pepper. Leave until cold. Beat the eggs and stir gradually into potato mixture. Blend thoroughly. Heat the ghee in a casserole dish on HIGH for 3 minutes. Pour in egg-potato mixture and cook on MEDIUM-HIGH for 8 minutes or till slightly set. Let it stand for 5 minutes. serve cut in wedges.

# Persian Recipes

## Khoreshe Holu (Peach Sauce with Chicken)

Serves : 5-6

### Ingredients:

1.5 kg chicken pieces  
10 g salt  
3 g freshly ground black pepper  
60 g ghee or butter  
60 g onions, chopped  
5 g turmeric powder  
225 ml water  
1 small piece cinnamon stick  
3 peaches, firm  
60 ml lemon or lime juice  
30 g brown sugar

### Method:

Wash chicken pieces and pat dry with paper towel. Season with salt and pepper. Keep aside. Heat half the ghee in a casserole dish on HIGH for 2 minutes. Add onions and cook for 3 minutes. Combine turmeric powder and water, and stir well. Add the chicken pieces and cinnamon stick. Cover and cook on MEDIUM-HIGH for 25 minutes. Peel peaches and cut into wedges, removing seeds. Heat remaining ghee in a separate bowl on HIGH for 2 minutes, add peaches and cook for a further 2 minutes. Arrange peaches on top of chicken. Sprinkle lemon juice and brown sugar. Cover and cook for 4 minutes on HIGH.



*Khoreshe Holu*

## Mohi Shekumpour (Stuffed Baked Fish)

Serves : 4-5

### Ingredients:

1 whole baking fish, approx  
1.5 kg  
10 g salt  
3 g freshly ground black pepper  
115 g finely chopped spring onions  
450 g chopped fresh herbs - parsley, coriander, dill and watercress, combined  
25 ml juice of 1 lemon  
60 ml olive oil  
herb sprigs and lemon wedges for garnish

### Method:

Clean and scale fish if necessary. Rub in salt and pepper, and keep aside. Combine spring onions and herbs with lemon juice and olive oil and season lightly. Fill cavity of fish with mixture and secure opening with cocktail picks or thread. Make 3 diagonal slashes on each side of fish. Place in a well-oiled casserole dish, and pour remaining lemon juice and oil over fish. Cover and cook on HIGH for 25 minutes until fish is tender. Serve garnished with fresh herb sprigs and lemon wedges.

## Abgushte Lubia Ghermez (Lamb and Bean Stew)

Serves : 6

### Ingredients:

1 can red kidneys beans (lubia ghermez)  
680 ml water  
1.5 kg lamb shoulder on the bone or 6 lamb foreshanks cut into 6 pieces  
60 g onions, finely chopped  
60 g ghee or butter  
5 tsp turmeric powder  
115 g tomato purée  
1 limu omani (dried lime) or  
10 ml lemon juice  
10 g salt  
3 g freshly ground black pepper

### Method:

Heat half the ghee in a covered casserole dish on HIGH for 2 minutes. Add the lamb meat and cook on MEDIUM-HIGH for 6 minutes. Remove from oven and set aside. Take remaining ghee, onions and turmeric powder, and cook on HIGH for 2 minutes. Add onion mixture to lamb and stir in beans, tomato purée and dried lime (pierced twice with a skewer) or the lemon juice. Add water, cover and cook on MEDIUM-HIGH for 25 minutes. Season with salt and pepper, and cook further for 20 minutes or until meat and beans are tender. Remove dried lime if used. Serve with pickles, fresh herbs, chopped onions, radishes and flat bread.

# Persian Recipes

## Dolmeh Kalam (Stuffed Cabbage Leaves with Sweet- Sour Sauce)

Serves : 6

### Ingredients:

18 cabbage leaves  
225 ml water  
750 g finely ground beef or lamb  
60 g onions, finely chopped  
60 g short grain rice  
60 g finely chopped parsley  
30 g finely chopped coriander  
5 g turmeric powder  
5 g salt  
3 g freshly ground black pepper  
115 g brown sugar  
115 ml cider vinegar

### Method:

Separate leaves from head of cabbage. Larger leaves may be halved and counted as 2. Blanch in a large pot of boiling water for 5 minutes until limp – do not overcook. Drain in a colander. Cut out thick section (ribs), only removing lower portion. Keep aside. Combine ground meat with onions, rice, herbs and turmeric. Add salt and pepper. Divide mixture into 18 portions. Place filling on base of cabbage leaf. Roll once, fold in sides and roll up into a firm package. Repeat with remaining portions. Line a casserole dish with cabbage trimmings or well-washed outer leaf. Pack rolls in close together in layers. Add water and place a heavy plate over rolls. Cover and cook on HIGH for 20 minutes. Blend sugar and vinegar, and pour over rolls. Tilt dish to blend liquids. Cover and cook for 15 minutes on MEDIUM. Serve with chelou or flat bread.

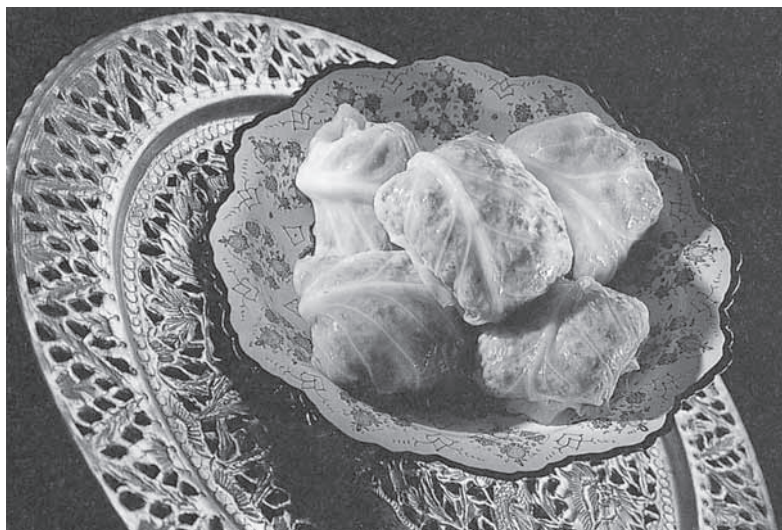

*Dolmeh Kalam*

## Shir Berenj (Rice Pudding)

Serves : 6

### Ingredients:

120 g short grain rice  
340 ml hot boiling water  
900 ml milk  
pinch salt  
60 g granulated sugar  
10-15 ml rose water  
3 g cardamom, ground  
honey for garnish, (optional)

### Method:

Rinse rice and place in a casserole dish with boiling water. Cook covered, for 10 minutes on MEDIUM-HIGH or until water is absorbed. Stir in milk, add salt and cook on MEDIUM-HIGH for 20 minutes, stirring after every 3 minutes until pudding is thick. Take care that it does not scorch. Add sugar, rose water and cardamom. Mix well. Serve warm or chilled in small bowls garnished with honey.

## Halvaye Shir (Milk Pudding)

Serves : 5-6

### Ingredients:

60 g ghee or unsalted butter  
115 g ground rice  
340 ml milk  
60 g granulated sugar  
15 ml rose water  
2-3 g cardamom, ground  
60 g chopped blanched almonds or pistachios nuts

### Method:

Heat ghee or butter in a casserole dish on HIGH for 4 minutes. Add ground rice and cook on MEDIUM-HIGH for 3 minutes, stirring often. Do not allow rice flour to colour. Add milk and cook on HIGH for 3 minutes, stirring after each minute until thick and bubbling. Blend in sugar, rose water and cardamom to taste. Cook on HIGH for 10 seconds. Pour into small bowls, sprinkle with nuts and serve warm or at room temperature. Alternatively pour into a lightly buttered 20 cm (8 inch) square cake pan and sprinkle with nuts. Leave until cold. Cut into squares to serve.