

# MATSUSHITA Compressor

## Model# DC57C84RBU6

Single Phase  
R-134a

115 V  
60 Hz

**Voltage Range** . . . . . 103 Volts to 127 Volts @ 60 Hz  
**Application** . . . . . Low Back Pressure  
**Compressor Cooling** . . . . . Fan/Static Cooling

**Refrigerant Control** . . . . . Capillary Tube  
**Evaporator**  
**Temp. Range** . . . . . -31°F to 23°F / -35°C to -5°C

### Rated Performance Data\*

	Cond. Temp I*	Cond. Temp II*
<b>Capacity</b> . . . . .	690 Btu/h ±7%	782 Btu/h ±7%
<b>E.E.R.</b> . . . . .	5.52 Btu/Wh ±7%	6.41 Btu/Wh ±7%
<b>Current</b> . . . . .	1.09 Amps	1.07 Amps

### Nominal Motor Data

Motor Input . . . . .	125 Watts	122 Watts
Rated Current . . . . .	1.04 Amps	
Type . . . . .	RSCR, PTC relay	

<b>Locked Rotor</b> . . . . .	8.6 Amps
<b>Start Current</b> . . . . .	15.8 Amps
<b>Coil Resistances</b>	Run . . . 4.68 Ohms
<b>@ 68°F (20°C)</b>	Start . . . 4.90 Ohms

### \*Test Conditions for Performance Specifications

Test Oil . . . . . ISO VG 10  
 Shell Temp . . . . . 150.0°F / 65.0°C  
 Condensing Temp . . . . . (I) 130.0°F / 54.4°C  
 . . . . . (II) 105.0°F / 40.6°C  
 Evaporating Temp . . . . . -10.0°F / -23.3°C  
 Ambient Temp . . . . . 90.0°F / 32.2°C  
 Gas Superheat . . . . . 90.0°F / 32.2°C  
 Liquid Sub-Cooling . . . . . 90.0°F / 32.2°C

### Electrical Accessories†

#### Overload Protector

Nominal Operating Characteristics

Model Name	4TM319NFBYY
Manufacturer	Texas Instruments
Temperature To . . . . .	Open: 248°F ± 9°F / 120°C ± 5°C
	Close: 142°F ± 16°F / 61°C ± 9°C
Trip Current. . . . .	@158°F (70°C) 2.82 Amps ± 7.5%
	@77°F (25°C) 12.5 Amps @ 16 sec. max.

#### P.T.C. Starting Device

Nominal Operating Characteristics

	PTH7M6R8	PTH490D-AS6R8	
Model Name	PTH7M6R8	PTH490D-AS6R8	
Manufacturer	Murata Mfg.	Murata Mfg.	
Base resistance			
@ 77°F(25°C) ±20%	6.8	6.8	Ohms
Power Consumption (max)	2.9	3.5	Watts
Operation time	0.6 to 1.8	1.0 to 2.7	seconds
Recovery time (max)	60	65	seconds

**Run Capacitor** . . . . . 12 µF 180 V (min.)

†Although these accessories are listed by UL/CSA for use with this compressor, Matsushita assumes no responsibility whatsoever for these or any other components sourced by the refrigeration system manufacturer from third parties.

### Performance Curves

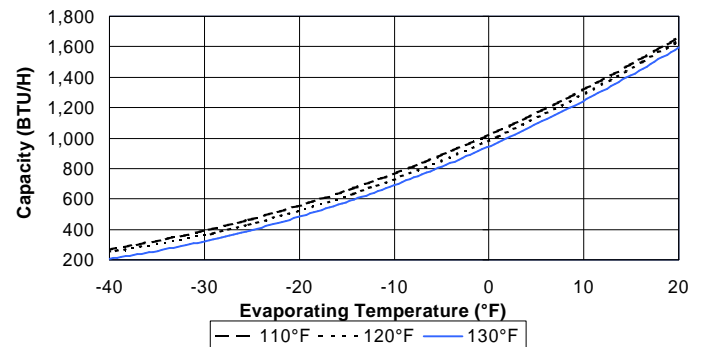
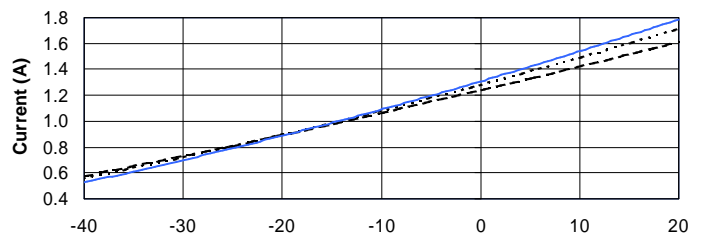
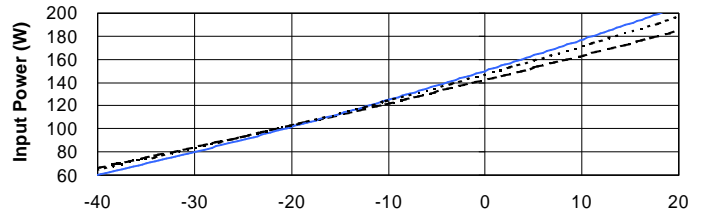

### 9 - Point Data

Condensing Temp.	Rating	Evaporating Temp.		
		-30°F	-10°F	+10°F
130°F	Btu/h	321	690	1,246
	Watts	80	125	177
	Amps	0.70	1.09	1.54
	E.E.R.	4.01	5.52	7.04
120°F	Btu/h	362	727	1,287
	Watts	83	124	171
	Amps	0.72	1.08	1.49
	E.E.R.	4.36	5.86	7.53
110°F	Btu/h	389	765	1,318
	Watts	84	122	163
	Amps	0.73	1.06	1.42
	E.E.R.	4.63	6.27	8.09

# Panasonic®

**Panasonic Industrial Company**  
**Refrigeration Products Department**  
 Tel: 201 - 392 - 4249  
 Fax: 201 - 392 - 4315

Rev#1-5/9

# MATSUSHITA Compressor

## MODEL# DC57C84RCU6

Single Phase  
R-134a

115 V  
60 Hz

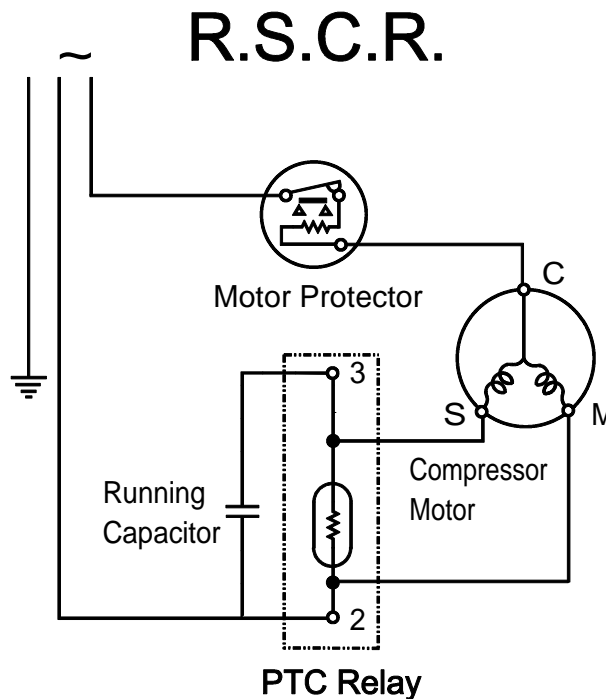
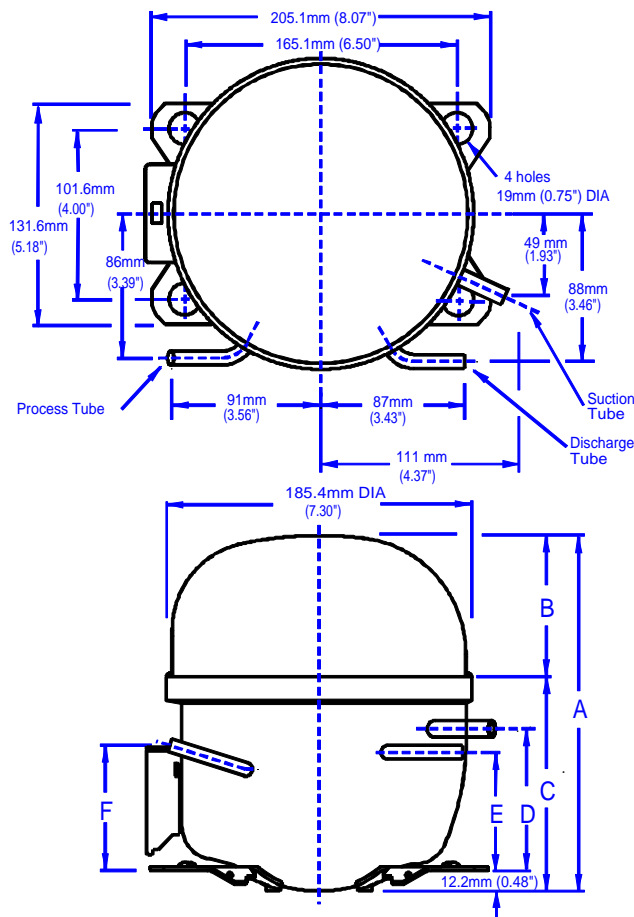

### Dimensions\*

	mm	inches
<b>A</b>	211.8	8.34
<b>B</b>	84.2	3.31
<b>C</b>	127.6	5.02
<b>D</b>	82.9	3.26
<b>E</b>	70.4	2.77
<b>F</b>	75.2	2.96

\* All dimensions are for reference only

This document sets forth certain operational parameters and conditions for operation of this product. If this product is operated outside of the parameters and conditions stated herein, buyer assumes sole and full responsibility and shall indemnify seller with respect to all product failures and all consequences thereof. Operation of the product outside of the parameters and conditions specified herein shall serve to invalidate all seller warranties, if any, with respect to the product. This document is for reference only. For specifications, please contact Panasonic's engineering department.

Tubes	Tube O.D.	Wall	Material
Suction	.0393 in. / 10 mm	0.037 in. / 0.95 mm	Copper
Process	0.33 in. / 8.3 mm	0.035 in. / 0.9 mm	Copper
Discharge	0.33 in. / 8.3 mm	0.035 in. / 0.9 mm	Copper

**U.L. File #** . . . . . SA 4615

**C.S.A. File #'s** . . . . . LR - 36593

General Data	Oil Charge	Net Weight With Oil	Approved Oils:
	250 cc ± 5 cc / 15.3 cu.in. ± 0.3 cu.in.	22.0 lbs, 10.0 kg	FREOL . . α 10, α 10E, α 15, α 15E, α 22, α 22E
			ICI . . . . . RL10H, RL15H, RL22H
			HENKEL . . . . . ProEco 10S, 15S, 22S
			Residual Moisture . . . . . 120 mg max.
			Impurities . . . . . 10 mg max.
			Displacement . . . . . 5.65 cc. / 0.345 cu. in.

# Panasonic®

**Panasonic Industrial Company**  
**Refrigeration Products Department**  
**Tel: 201 - 392 - 4249**  
**Fax: 201 - 392 - 4315**

Rev#1-5/9