



<b>System</b>	SC-HT822V
<b>Main unit</b>	SA-HT822V
<b>Front and surround speakers</b>	SB-FS822
<b>Center speaker</b>	SB-PC820
<b>Active subwoofer</b>	SB-WA822

Operations in these instructions are described mainly with the remote control, but you can do the operations on the main unit if the controls are the same.



INTRO

### CAUTION!

DO NOT INSTALL OR PLACE THIS UNIT IN A BOOKCASE, BUILT-IN CABINET OR IN ANOTHER CONFINED SPACE. ENSURE THE UNIT IS WELL VENTILATED. TO PREVENT RISK OF ELECTRIC SHOCK OR FIRE HAZARD DUE TO OVERHEATING, ENSURE THAT CURTAINS AND ANY OTHER MATERIALS DO NOT OBSTRUCT THE VENTILATION VENTS.

### WARNING:

TO REDUCE THE RISK OF FIRE, ELECTRIC SHOCK OR PRODUCT DAMAGE, DO NOT EXPOSE THIS APPARATUS TO RAIN, MOISTURE, DRIPPING OR SPLASHING AND THAT NO OBJECTS FILLED WITH LIQUIDS, SUCH AS VASES, SHALL BE PLACED ON THE APPARATUS.

### CAUTION!

THIS PRODUCT UTILIZES A LASER. USE OF CONTROLS OR ADJUSTMENTS OR PERFORMANCE OF PROCEDURES OTHER THAN THOSE SPECIFIED HEREIN MAY RESULT IN HAZARDOUS RADIATION EXPOSURE. DO NOT OPEN COVERS AND DO NOT REPAIR YOURSELF. REFER SERVICING TO QUALIFIED PERSONNEL.

### Note to CATV system installer:

This reminder is provided to call the CATV system installer's attention to Article 820-40 of the NEC that provides guidelines for proper grounding and, in particular, specifies that the cable ground shall be connected to the grounding system of the building, as close to the point of cable entry as practical.

<b>CAUTION</b>	- LASER RADIATION WHEN OPEN. DO NOT STARE INTO BEAM. FDA 21 CFR / Class II
<b>CAUTION</b>	- VISIBLE AND INVISIBLE LASER RADIATION WHEN OPEN. AVOID EXPOSURE TO BEAM. IEC60825-1 / Class 3B
<b>VARNING</b>	- SYNLIIG OCH USYNLIIG LASERSTRÅLNING NÄR DENNA DEL ÄR ÖPPNAD. BESTRÄKT EJ STRÅLEN.
<b>ADVARSEL</b>	- SYNLIIG OG USYNLIIG LASERSTRÅLING VED ÅBNING. UNDGÅ UDSÆTTELSE FOR STRÅLING.
<b>ADVARSEL</b>	- SYNLIIG OG USYNLIIG LASERSTRÅLING NÄR DEKSEL ÅPNES. UNNGÅ EKSPONERING FOR STRÅLEN.
<b>VARO!</b>	- AVATTAESSA OLET ALTTIINA NÄKYVÄÄ JA NÄKYMÄTÖN LASERSÄTEILYLLE. ÄLÄ KATSO SÄTEESEEN.
<b>VORSICHT</b>	- SICHTBARE UND UNSICHTBARE LASERSTRÄHLUNG, WENN ABDECKUNG GEÖFFNET. NICHT DEN STRAHL ANSETZEN.
<b>ATTENTION</b>	- RAYONNEMENT LASER VISIBLE ET INVISIBLE EN CAS D'OUVERTURE. EXPOSITION DANGEREUSE AU FAISCEAU.
<b>注意</b>	- 打开時有可见及不可见激光辐射。避免激光束照射。
<b>注意</b>	- ここを開くと可視及び不可視レーザー光が出ます。ビームを見たり、触れたりしないで下さい。 RCLXS0054

(Inside of product)

Before moving the unit, ensure the disc trays and video cassette slot are empty.

Failure to do so will risk severely damaging the discs, video cassette tape and the unit.

Avoid use or placing highly magnetic devices (Speakers etc.) or devices that emit strong electro-magnetic waves (mobile telephones etc.) near the main unit.

- The above may result in problems with audio and video, and recorded content may be lost.
- Be extra cautious when you are using a plasma television, keeping these devices as far away as possible.

### Stacking

Place the unit in a horizontal position, and do not place anything heavy on it.

### CAUTION:

This equipment has been tested and found to comply with the limits for a Class B digital device, pursuant to Part 15 of the FCC Rules.

These limits are designed to provide reasonable protection against harmful interference in a residential installation. This equipment generates, uses and can radiate radio frequency energy and, if not installed and used in accordance with the instructions, may cause harmful interference to radio communications. However, there is no guarantee that interference will not occur in a particular installation. If this equipment does cause harmful interference to radio or television reception, which can be determined by turning the equipment off and on, the user is encouraged to try to correct the interference by one or more of the following measures:

- Reorient or relocate the receiving antenna.
- Increase the separation between the equipment and receiver.
- Connect the equipment into an outlet on a circuit different from that to which the receiver is connected.
- Consult the dealer or an experienced radio/TV technician for help.

Any unauthorized changes or modifications to this equipment would void the user's authority to operate this device.

This device complies with Part 15 of the FCC Rules. Operation is subject to the following two conditions: (1) This device may not cause harmful interference, and (2) this device must accept any interference received, including interference that may cause undesired operation.



**CAUTION**  
RISK OF ELECTRIC SHOCK  
DO NOT OPEN



CAUTION: TO REDUCE THE RISK OF ELECTRIC SHOCK, DO NOT REMOVE SCREWS. NO USER-SERVICEABLE PARTS INSIDE. REFER SERVICING TO QUALIFIED SERVICE PERSONNEL.



The lightning flash with arrowhead symbol, within an equilateral triangle, is intended to alert the user to the presence of uninsulated "dangerous voltage" within the product's enclosure that may be of sufficient magnitude to constitute a risk of electric shock to persons.



The exclamation point within an equilateral triangle is intended to alert the user to the presence of important operating and maintenance (servicing) instructions in the literature accompanying the appliance.

- Operating while there is condensation in the unit or on the cassette tape may cause the tape to catch upon the cylinder resulting in the tape being cut, or not being able to remove the cassette tape from the unit. The unit also may not work properly if the unit's cylinder or heads have been damaged.
- Wait 1–2 hours for condensation to evaporate (do not operate the unit during this time).



**Accessories** . . . . . 4  
 The remote control . . . . . 4  
**IMPORTANT SAFETY INSTRUCTIONS** . . . . . 5  
**Tape information** . . . . . 5  
**Discs that can be played** . . . . . 6  
**Disc handling** . . . . . 6

**Control reference guide** . . . . . 7  
 Remote control—common buttons . . . . . 7  
 Remote control—DVD operation . . . . . 7  
 Remote control—VHS operation . . . . . 8  
 Remote control—TUNER operation . . . . . 8  
 Main unit and subwoofer . . . . . 9  
 Main unit display . . . . . 9



**Simple setup**  
**STEP 1 Assembly and connection of front and surround speakers** . . . . . 10  
 Other speaker setup options (Center speaker only) . . . . . 11  
**STEP 2 Locating** . . . . . 12  
**STEP 3 Connecting speakers with the subwoofer** . . . . . 13

**STEP 4 Television** . . . . . 14  
 Basic connection . . . . . 14  
 For better video from DVD . . . . . 15  
**STEP 5 Radio and system connection** . . . . . 16  
**STEP 6 Plug-in Auto Tuning** . . . . . 17  
**STEP 7 Operating the television** . . . . . 18  
**STEP 8 DVD QUICK SETUP** . . . . . 19



**Basic play** . . . . . 20  
**Convenient functions** . . . . . 22  
 Position memory . . . . . 22  
 Zoom . . . . . 22  
 Subtitle . . . . . 22  
 Audio . . . . . 22  
 Multi Re-master . . . . . 23  
 Page skip . . . . . 23  
 CD Mode (CD sequential play) . . . . . 23  
 Quick replay . . . . . 23  
 All group/Program/Random play . . . . . 24  
 Repeat play . . . . . 25

**Using navigation menus** . . . . . 26  
 Playing data discs . . . . . 26  
 Playing HighMAT discs . . . . . 27  
 Playing the programs . . . . . 27  
 Playing a play list . . . . . 27  
**Using On-Screen Menus** . . . . . 28  
 Main menus . . . . . 28  
 Other settings . . . . . 29  
**Changing the player settings** . . . . . 30  
 Changing the delay time (Speaker Setting) . . . . . 31



**Playback** . . . . . 32  
 Picture mode . . . . . 33  
 Repeat play . . . . . 33  
 Manual tracking . . . . . 33  
 Vertical locking adjustment . . . . . 33  
**Manual recording** . . . . . 34  
 Recording a program . . . . . 34  
 Using another source while recording . . . . . 35  
 Recording from other equipment . . . . . 35  
**Timer recording** . . . . . 36

**Finding programs with the Jet Navigator and VHS Index Search System (VISS)** . . . . . 38  
 Saving Jet Navigator data . . . . . 38  
 Using the Jet Navigator to find programs . . . . . 38  
 Finding programs—VHS Index Search System (VISS) . . . . . 39  
**Changing settings** . . . . . 40  
 LANGUAGE . . . . . 40  
 CLOCK SET . . . . . 40  
 CHANNEL SET . . . . . 41  
 OPTION . . . . . 42  
 On-screen display . . . . . 43  
 Changing audio . . . . . 43



**The radio** . . . . . 44  
 Automatic presetting . . . . . 44  
 Manual tuning . . . . . 44  
 Selecting the preset channels . . . . . 44  
 Optional FM antenna connection . . . . . 45  
**Sound field and sound quality** . . . . . 46  
 Sound Field Control . . . . . 46  
 Super Surround . . . . . 46  
 Center Focus . . . . . 46  
 Dolby Pro Logic II . . . . . 46  
 Dolby Pro Logic . . . . . 46

Custom Sound Memory . . . . . 47  
 Down-mixing . . . . . 47  
 Subwoofer level . . . . . 47  
 Speaker level adjustments . . . . . 47  
**Other convenient features** . . . . . 48  
 Sleep timer . . . . . 48  
 Muting . . . . . 48  
 Using headphones . . . . . 48



**Optional connections** . . . . . 49  
 Listening to an external source/  
 Recording to other equipment . . . . . 49  
 Connecting a cable TV box/satellite receiver . . . . . 49  
 If the antenna connector doesn't match . . . . . 50

**Specifications** . . . . . 51  
**Troubleshooting guide** . . . . . 52  
**Maintenance** . . . . . 54  
**Product Service** . . . . . 54  
**Limited Warranty** . . . . . 55  
**Index** . . . . . Back cover



# Accessories



Please check and identify the supplied accessories. Use numbers indicated in parentheses when asking for replacement parts.

To order accessories, refer to "Accessory Purchases" on page 55.



- 1 **Remote control**  
(EUR7722X20)
- 2 **Batteries**  
for remote control
- 2 **AC power supply cords**  
(K2CB2CB00006)
- 1 **AM loop antenna**  
(N1DAAAA00002)
- 1 **FM indoor antenna**  
(RSA0007-L)
- 1 **Video cable**  
(RJL1P016B15A)
- 1 **75 Ω coaxial cable**  
(VJA1125)
- 1 **System cable**  
(K1HA25HA0001)
- 5 **Speaker cables**  
3×4-m (13-foot) cables  
(REE1203A-J)  
2×10-m (33-foot) cables  
(REE1203C-J)
- 1 **Sheet of speaker-cable stickers**
- 8 **Silver screws**  
(XSN5+16FN)
- 4 **Black screws**  
(XTB3+10JFZ)
- 4 **Clampers**  
(RMR1503-W)
- 1 **Antenna plug**  
(K2RC021B0001)

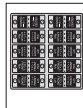
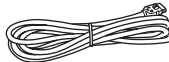
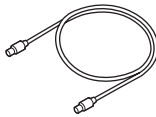
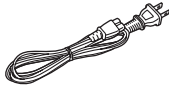

**Note**

The included AC power supply cords are for use with this unit only. Do not use them with other equipment.

# The remote control

Remote control

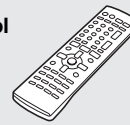

Batteries



**Batteries**

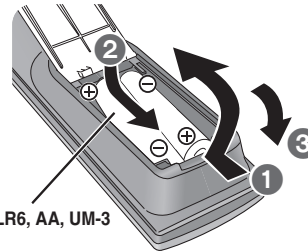

R6/LR6, AA, UM-3

- Insert so the poles (+ and -) match those in the remote control.
- Do not use rechargeable type batteries.

**Do not:**

- mix old and new batteries.
  - use different types at the same time.
  - heat or expose to flame.
  - take apart or short circuit.
  - attempt to recharge alkaline or manganese batteries.
  - use batteries if the covering has been peeled off.
- Mishandling of batteries can cause electrolyte leakage which can damage items the fluid contacts and may cause a fire.

Remove if the remote control is not going to be used for a long period of time. Store in a cool, dark place.

**Use**

Aim at the sensor (→ page 9), avoiding obstacles, at a maximum range of 7 m (23 feet) directly in front of the unit.

**User memo:**

DATE OF PURCHASE _____
DEALER NAME _____
DEALER ADDRESS _____
TELEPHONE NUMBER _____

The model number and serial number of this product can be found on either the back or the bottom of the unit. Please note them in the space provided below and keep for future reference.	
MODEL NUMBER _____	SC-HT822V
SERIAL NUMBER _____	

# IMPORTANT SAFETY INSTRUCTIONS

Read these operating instructions carefully before using the unit. Follow the safety instructions of the unit and the power supply cord listed below. Keep these operating instructions handy for future reference.

- 1) Read these instructions.
- 2) Keep these instructions.
- 3) Heed all warnings.
- 4) Follow all instructions.
- 5) Do not use this apparatus near water.
- 6) Clean only with dry cloth.
- 7) Do not block any ventilation openings. Install in accordance with the manufacturer's instructions.
- 8) Do not install near any heat sources such as radiators, heat registers, stoves, or other apparatus (including amplifiers) that produce heat.
- 9) Do not defeat the safety purpose of the polarized or grounding-type plug. A polarized plug has two blades with one wider than the other. A grounding-type plug has two blades and a third grounding prong. The wide blade or the third prong are provided for your safety. If the provided plug does not fit into your outlet, consult an electrician for replacement of the obsolete outlet.
- 10) Protect the power supply cord from being stepped on, particularly at plugs, power outlets, and the point where they exit the apparatus.
- 11) Only use attachments recommended by the manufacturer.
- 12) Use only with the voltage, frequency, and power rating specified by the manufacturer. Do not use the apparatus with a power source other than that specified. When using caution when moving the cord or the plug, do not pull on the cord to avoid injury from tripping.
- 13) Unplug this apparatus during lightning storms or when unused for long periods of time.
- 14) Refer all servicing to qualified service personnel. Servicing is required when the apparatus has been damaged in any way, such as power-supply cord or plug is damaged, liquid has been spilled or objects have fallen into the apparatus, the apparatus has been exposed to rain or moisture, does not operate normally, or has been dropped.



## Tape information

### ■ Tapes

- You can use tapes with the VHS and S-VHS marks, but this unit is unable to make full use of the characteristics of S-VHS tapes.
- Break out the tape's tab to prevent accidental erasure. Cover the hole with a double layer of adhesive tape when you want to use the tape for recording again.

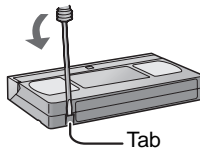

### ■ Tapes

Poor quality tapes may cause the heads to become dirty and the tape to be damaged. Replace the tapes regularly and discard when they become unusable.

### ■ S-VHS Quasi Playback (SQPB)

You can play tapes recorded with the S-VHS system, however some noise may occur with some tapes and this unit cannot take advantage of S-VHS's high resolution. This unit cannot make S-VHS recordings.

Selecting fine audio equipment is a personal choice. If you are considering how you can maximize your listening pleasure, consider the Consumer Electronics Group's recommendations. The Consumer Electronics Association's (CEA) recommendations are based on the sound that most people have hearing.

We recommend that you use a sound system that can reproduce sound that is clear and loud. Sound can be decreased by your environment. For more information, see the CEA's recommendations at [www.ces-association.org](http://www.ces-association.org).

# Discs that can be played



Disc	Logo	Indication in these operating instructions	Remarks
DVD-RAM		<b>RAM</b>	Recorded using Version 1.1 of the Video Recording Format (a unified video recording standard). ● Recorded with DVD video recorders, DVD video cameras, personal computers, etc. ● Remove discs from their cartridges before use.
		<b>JPEG</b>	Recorded using the DCF (Design rule for Camera File system) standard. ● Recorded with Panasonic DVD-Video recorders ● To play JPEG files, select "Play as Data Disc" in Other Menu (→ page 29).
DVD-Audio		<b>DVD-A</b>	—
		<b>DVD-V</b>	Some DVD-Audio discs contain DVD-Video content. To play DVD-Video content, select "Play as DVD-Video" in Other Menu (→ page 29).
DVD-Video		<b>DVD-V</b>	—
DVD-R			Panasonic DVD-R recorded and finalized* on a Panasonic DVD-Video recorders or DVD-Video cameras are played as DVD-Video on this unit.
Video CD		<b>VCD</b>	—
SVCD			Conforming to IEC62107
CD		<b>CD</b>	This unit is compatible with HDCD, but does not support the Peak Extend function. (A function which expands the dynamic range of high level signals) HDCD-encoded CDs sound better because they are encoded with 20 bits, as compared with 16 bits for all other CDs. ● During HDCD play, "HDCD" lights on the unit's display.
CD-R CD-RW	—	<b>WMA</b> <b>MP3</b> <b>JPEG</b> <b>CD</b> <b>VCD</b>	● This unit can play CD-R/RW (audio recording disc) recorded with the formats on the left. Close the sessions or finalize* the disc after recording. ● <b>HighMAT discs</b> WMA, MP3 or JPEG files only. To play without using the HighMAT function, select "Play as Data Disc" in Other Menu (→ page 29).

\*A process that allows play on compatible equipment.

● It may not be possible to play the above discs in all cases due to the type of disc or condition of the recording.

## Discs that cannot be played

PAL discs (except DVD-Audio), DVD-ROM, CD-ROM, CDV, CD-G, DVD+R, +RW, DVD-RW, SACD, Divx Video Discs and Photo CD, DVD-RAM that cannot be removed from their cartridge, 2.6-GB and 5.2-GB DVD-RAM, and "Chaoji VCD" available on the market including CVD, DVCD and SVCD that do not conform to IEC62107.

## Audio format of DVDs

This unit automatically recognizes and decodes discs with these symbols.



HighMAT™ and the HighMAT logo are either trademarks or registered trademarks of Microsoft Corporation in the United States and/or other countries.



HDCD®, HDCD®, High Definition Compatible Digital® and Pacific Microsonics™ are either registered trademarks or trademarks of Pacific Microsonics, Inc. in the United States and/or other countries.

HDCD system manufactured under license from Pacific Microsonics, Inc. This product is covered by one or more of the following: In the USA : 5,479,168, 5,638,074, 5,640,161, 5,808,574, 5,838,274, 5,854,600, 5,864,311, 5,872,531, and in Australia: 669114, with other patents pending.

## Disc handling

### To prevent damage

Do not;

- load more than one disc per tray.
- close the drawer by hand.

### To clean discs

**DVD-A** **DVD-V** **VCD** **CD**

Wipe with a damp cloth and then wipe dry.

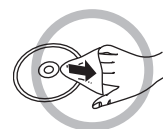

**RAM** **DVD-R**

- Clean with an optional DVD-RAM/PD disc cleaner (LF-K200DCA1, where available).
- Never use cloths or cleaners for CDs etc.

### Handling precautions

- Do not attach labels or stickers to discs (This may cause disc warping, rendering it unusable).
- Do not write on the label side with a ball-point pen or other writing instrument.
- Do not use record cleaning sprays, benzene, thinner, static electricity prevention liquids or any other solvent.
- Do not use scratch-proof protectors or covers.
- Do not use the following discs:
  - Discs with exposed adhesive from removed stickers or labels (rented discs etc).
  - Discs that are badly warped or cracked.
  - Irregularly shaped discs, such as heart shapes.



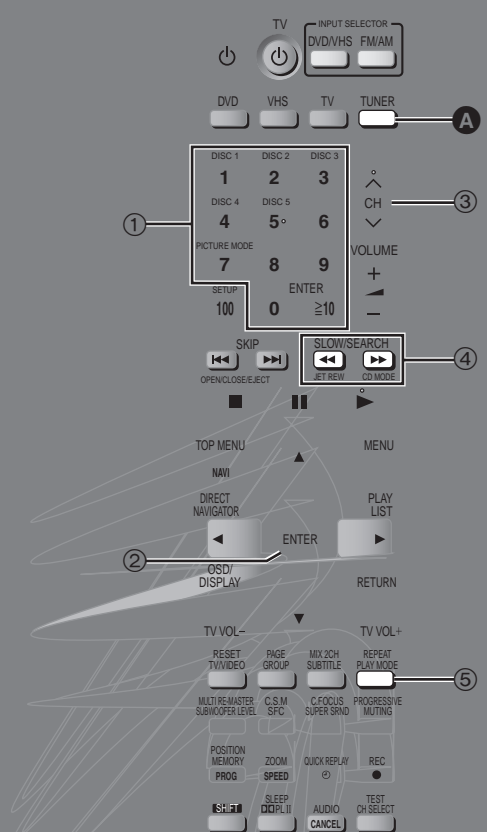



# Simple setup

## STEP 1 Assembly and connection of front and surround speakers

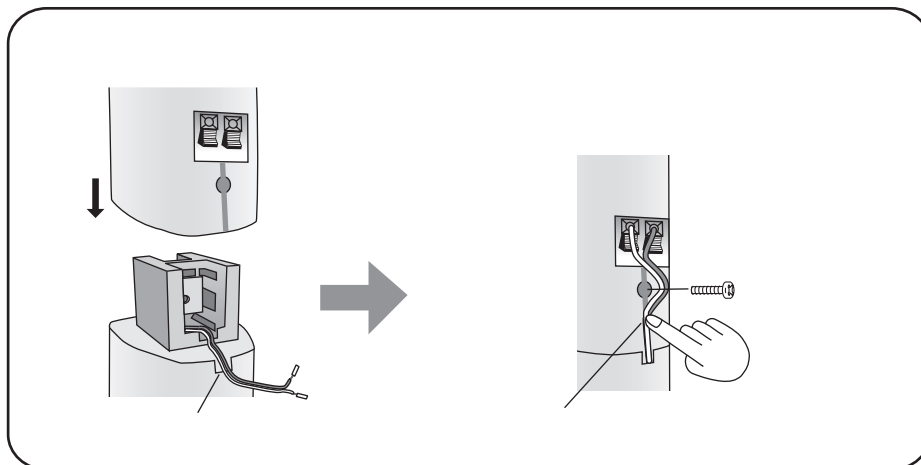
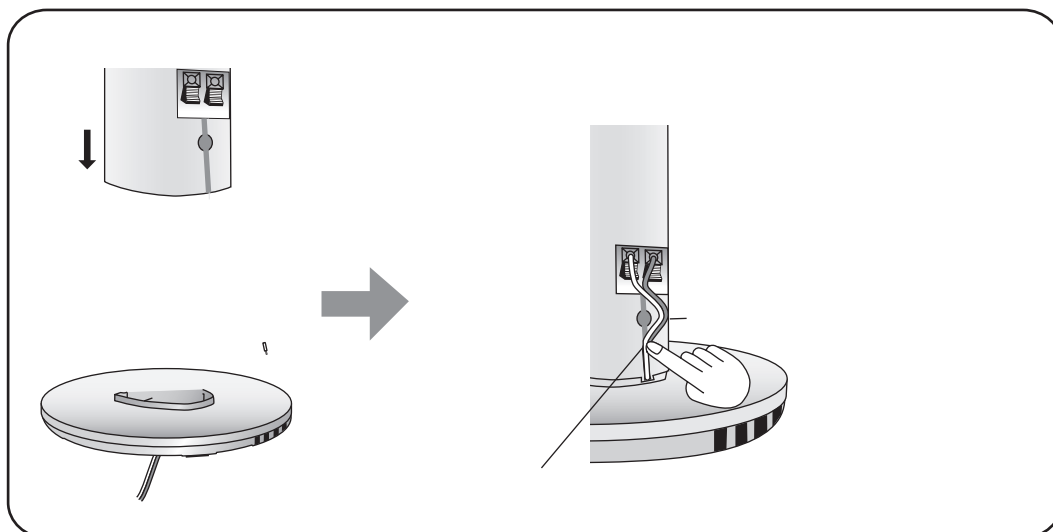

- You can attach the speakers directly to their bases (if you want to put them on shelves, for example).

### Note

- Never short-circuit positive (+) and negative (-) speaker wires.  
Be sure to connect only positive (copper) wires to positive (+) terminals and negative (silver) wires to negative (-) terminals.  
Incorrect connection can damage the speakers.

### Caution

Hold the speakers by the sides. Applying pressure to the front net can damage the speaker.

# Other speaker setup options (Center speaker only)

## ■ Attaching to a wall

### Note

- The wall or pillar on which the speakers are to be attached should be capable of supporting 10 kg (22 lb.) per screw. Consult a qualified building contractor when attaching the speakers to wall. Improper attachment may result in damage to the wall and speakers.
- Do not attempt to attach these speakers to walls using methods other than those described in this manual.

### 1 Drive a screw (not included) into a wall.

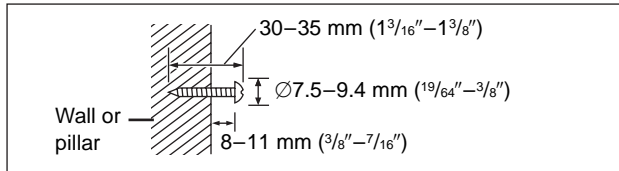

### 2 Fit the speaker securely onto the screws with the holes.

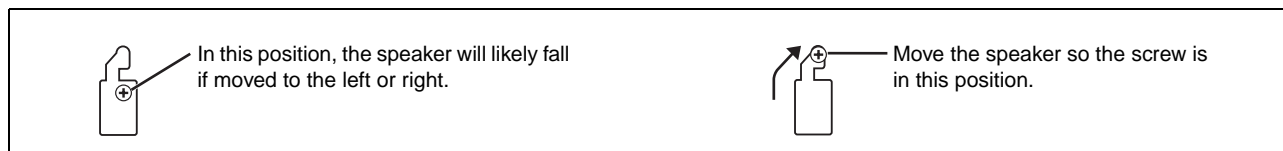
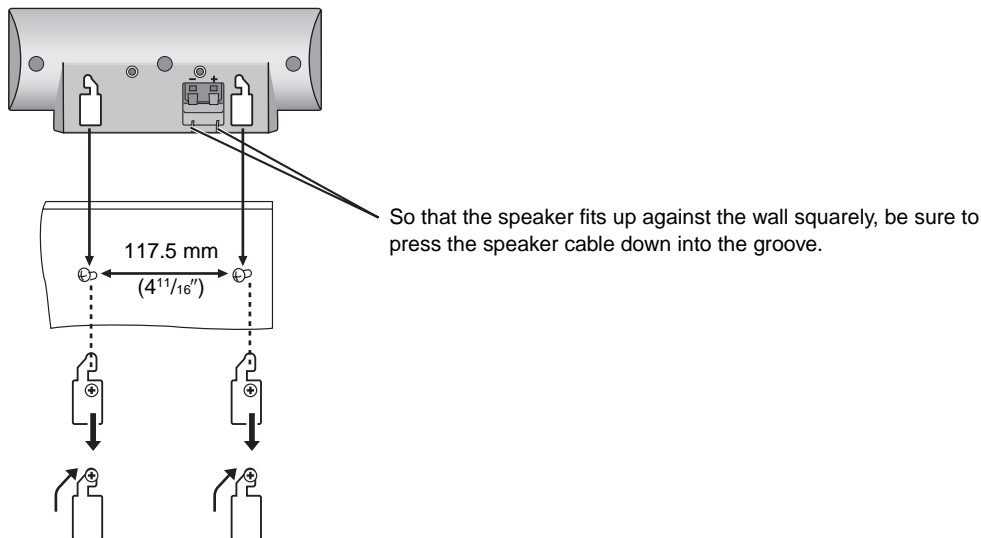

## ■ Fitting speaker stands (not included)

Ensure the stands meet these conditions before purchasing them. Observe the diameter and length of the screws and the distance between screws as shown in the diagram.

- The stands must be able to support over 10 kg (22 lb.).
- The stands must be stable even if the speakers are in a high position.

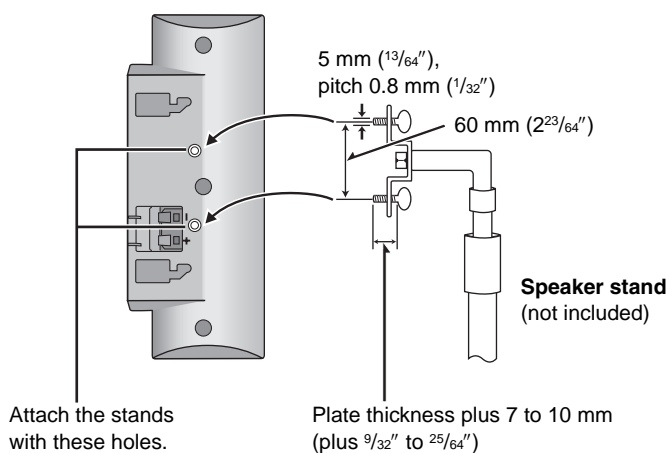

# STEP 2 Locating

How you set up your speakers can affect the bass and the sound field. Note the following points.

- Place speakers on flat secure bases.
- Placing speakers too close to floors, walls, and corners can result in excessive bass. Cover walls and windows with thick curtains.
- The front left, right and surround speakers are all the same.

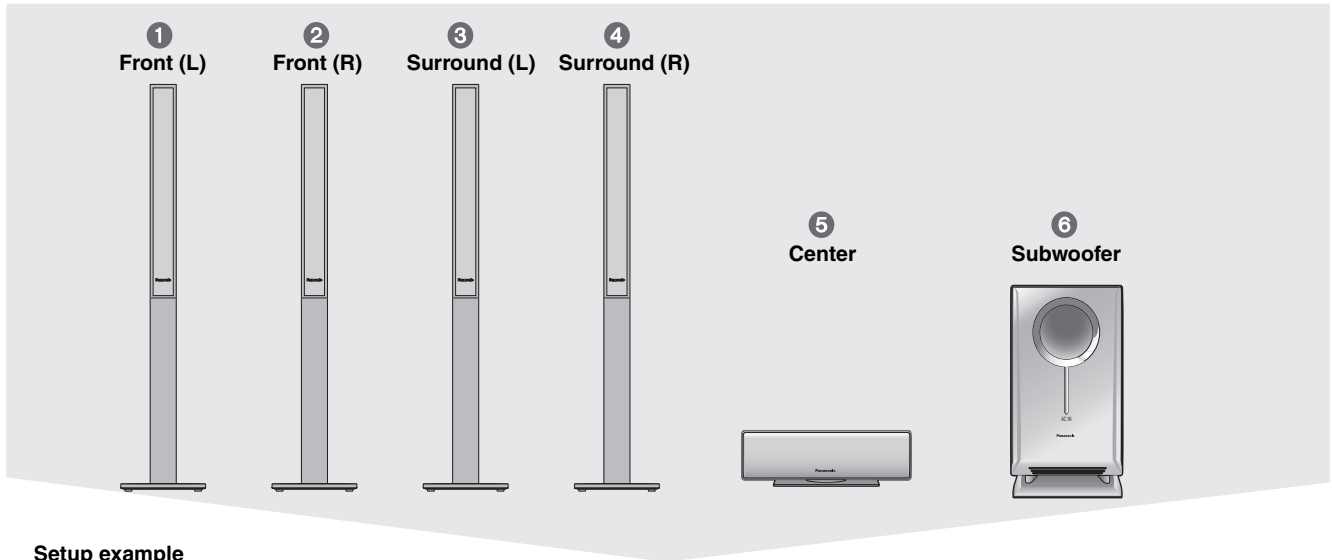

Setup example

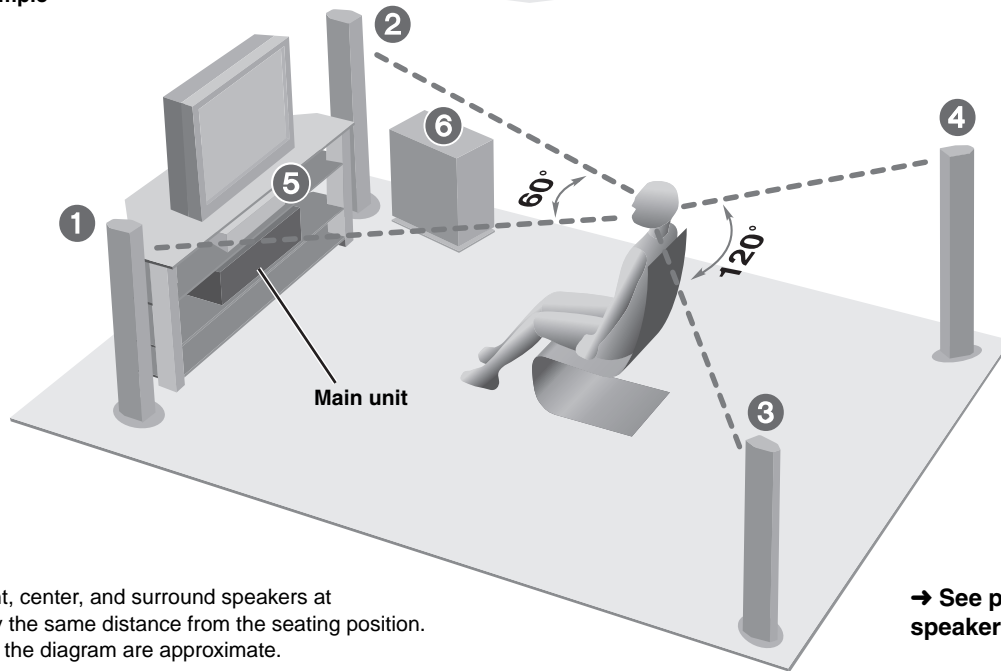

Place the front, center, and surround speakers at approximately the same distance from the seating position. The angles in the diagram are approximate.

→ See page 11 for other speaker setup options.

### Use only supplied speakers

Using other speakers can damage the unit and sound quality will be negatively affected.

- Set the speakers up on an even surface to prevent them from falling. Take proper precautions to prevent the speakers from falling if you cannot set them up on an even surface.

### Main unit

#### Note

Keep your speakers at least 10 mm (<sup>13</sup>/<sub>32</sub>" ) away from the system for proper ventilation.

### Center speaker

- Vibration caused by the center speaker can disrupt the picture if it is placed directly on the television. Put the center speaker on a rack or shelf.
- To prevent the speakers from falling do not place the speakers directly on top of the television.

### Subwoofer

Place to the right or left of the television, on the floor or a sturdy shelf so that it won't cause vibration.

Leave 10 cm (4") at the rear for ventilation.

### Notes on speaker use

- You can damage your speakers and shorten their useful life if you play sound at high levels over extended periods.
- Reduce the volume in the following cases to avoid damage.
  - When playing distorted sound.
  - When the speakers are receiving howling from a record player, noise from FM broadcasts, or continuous signals from an oscillator, test disc, or electronic instrument.
  - When adjusting the sound quality.
  - When turning the unit on or off.



### Caution

- The main unit and supplied speakers are only to be used as indicated in this setup. Failure to do so may lead to damage to the amplifier and/or the speakers, and may result in the risk of fire. Consult a qualified service person if damage has occurred or if you experience a sudden change in performance.
- Do not attempt to attach these speakers to walls using methods other than those described in this manual.



SETUP



# STEP 4 Television

## Basic connection

75 Ω coaxial cable

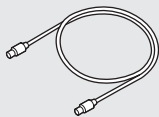

Video cable



SETUP

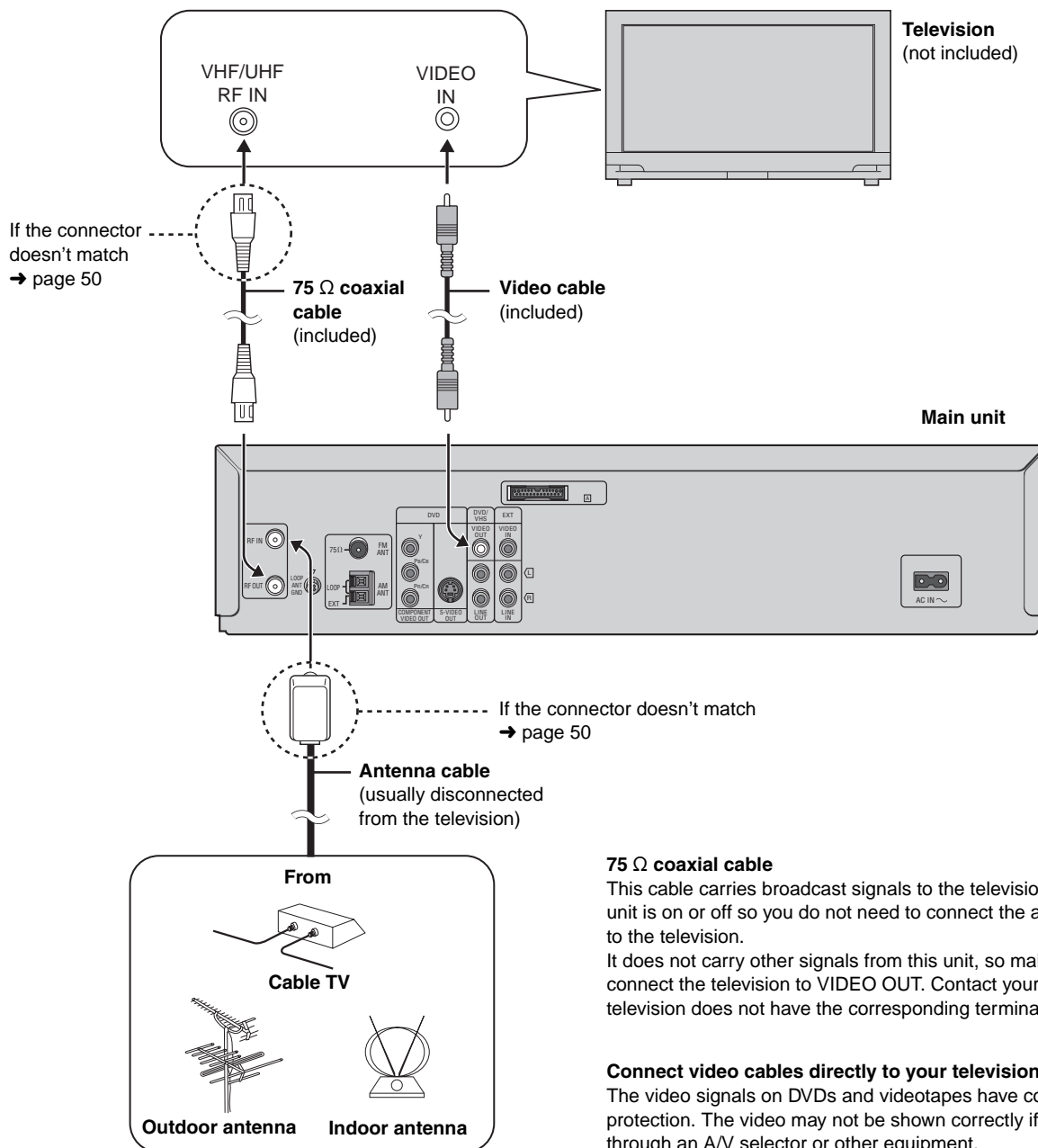

### 75 Ω coaxial cable

This cable carries broadcast signals to the television whether the unit is on or off so you do not need to connect the antenna directly to the television.

It does not carry other signals from this unit, so make sure you connect the television to VIDEO OUT. Contact your dealer if your television does not have the corresponding terminal.

### Connect video cables directly to your television

The video signals on DVDs and videotapes have copyright protection. The video may not be shown correctly if you connect through an A/V selector or other equipment.

### To enjoy cable and satellite television

Connection → page 49

Subscribe to a cable or satellite company.

### If irregular coloring occurs on your television

The supplied speakers are designed to be used close to a television, but the picture may be affected with some televisions and setup combinations.

### If this occurs, turn the television off for about 30 minutes.

The television's demagnetizing function should correct the problem. If it persists, move the speakers further away from the television.

you

#### S-video terminal

The S-video terminal achieves a more vivid picture than the VIDEO terminal by separating the chrominance (C) and luminance (Y) signals. (Actual results depend on the television.)

Connect to a different terminal group than that you used for the video cable (e.g., "VIDEO 2").

Picture from this unit's VHS will not appear when you use the same group input terminal connections because the S-video terminal input takes precedence.

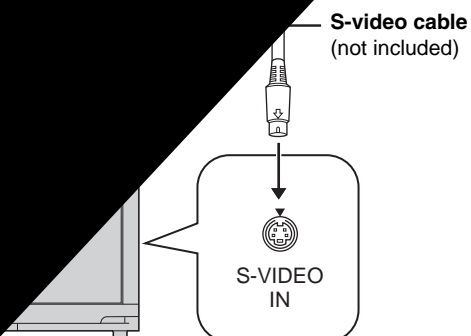

# STEP 5 Radio and system connection



SETUP

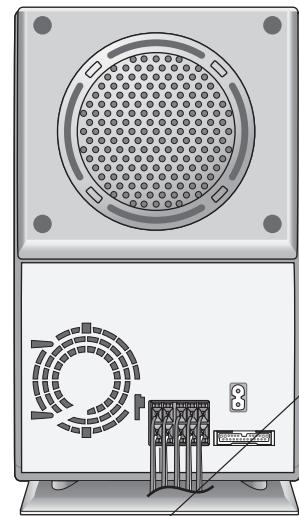
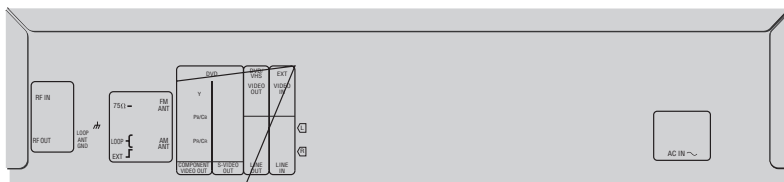

## Conserving power

The system consumes a small amount of power, even when it is turned off. The amount of power used depends on the display setting (→ page 42):

BRIGHT: 3.8 W    DIM: 3.5 W    OFF: 2.2 W

To save power when the unit is not to be used for a long time, unplug it from the household AC outlet.

You will need to reset some memory items after plugging the unit.

# STEP 6 Plug-in Auto Tuning

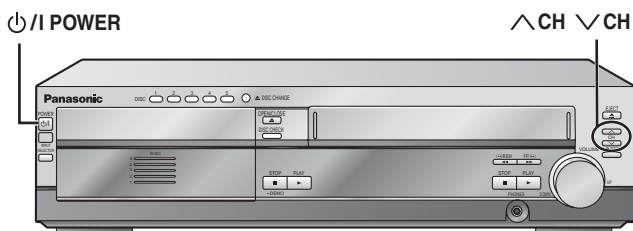
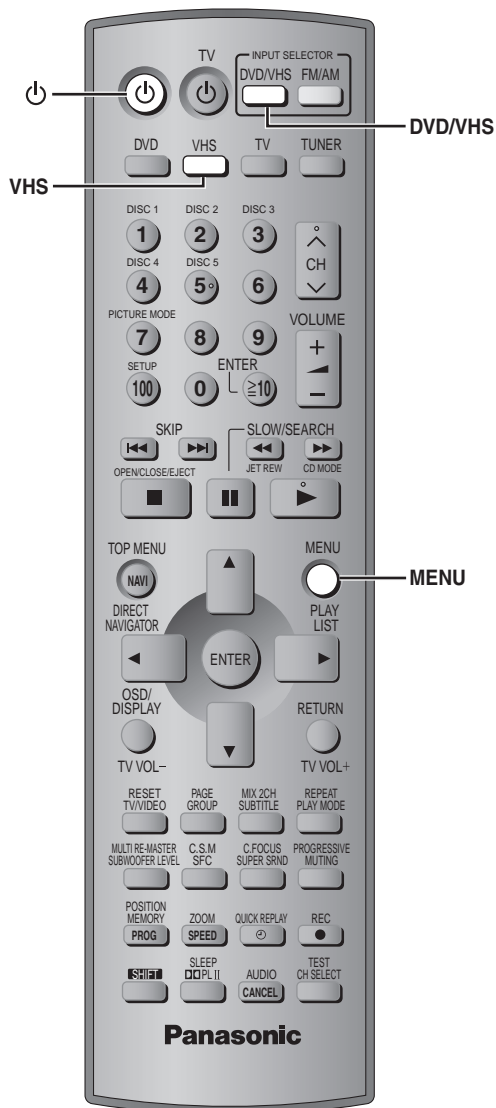

After plugging the unit into your household AC outlet and pressing [POWER] to turn the unit on for the first time, the unit automatically tunes in all the channels it can receive and sets the clock.

The unit determines the type of transmission, TV or CATV, as follows:

- TV: when there are less than 5 CATV channels.
- CATV: when there are 5 or more CATV channels.

### Preparation

- Confirm that the antenna is connected correctly.
- Turn on the television and select the video input for the VHS.
- Press [VHS] to put the remote control in VHS mode.

### Press [POWER] to turn on the unit.

Plug-in Auto Tuning starts and the unit puts the stations it can receive into channels (→ page 41, Channel range).

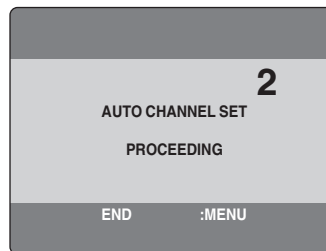

The unit starts auto clock setting when finished, then displays the time.

### Note

If auto tuning stops partway (by changing the source, turning the unit off, or due to a power failure.)

- 1 Disconnect the AC power supply cord on the main unit and then reconnect it.
- 2 Turn on the main unit.

### To cancel partway

Press [MENU].

### To start Plug-in Auto Tuning again (after relocation, for example)

#### Preparation

- Press [POWER] to turn on the unit.
- Make sure there is no video cassette tape loaded in the unit.
- Press [DVD/VHS] to select "VHS" as the source.

- 1 Press and hold [^ CH] and [v CH] on the main unit simultaneously for 3 seconds until the channel changes to "2".



Disappears → 2

- 2 Disconnect the AC power supply cord on the main unit and then reconnect it.
- 3 Turn on the main unit. Plug-in Auto Tuning restarts.

Antenna system and channel captions all revert to the default values when you perform the procedure above. Reset the timer recording settings. (If necessary reset the clock first. → page 40, CLOCK SET)

### To set the channels manually (→ page 41).

### If the unit couldn't set the clock automatically

The MANUAL CLOCK SET screen appears. Set the time manually (→ page 40).



# STEP 7 Operating the television

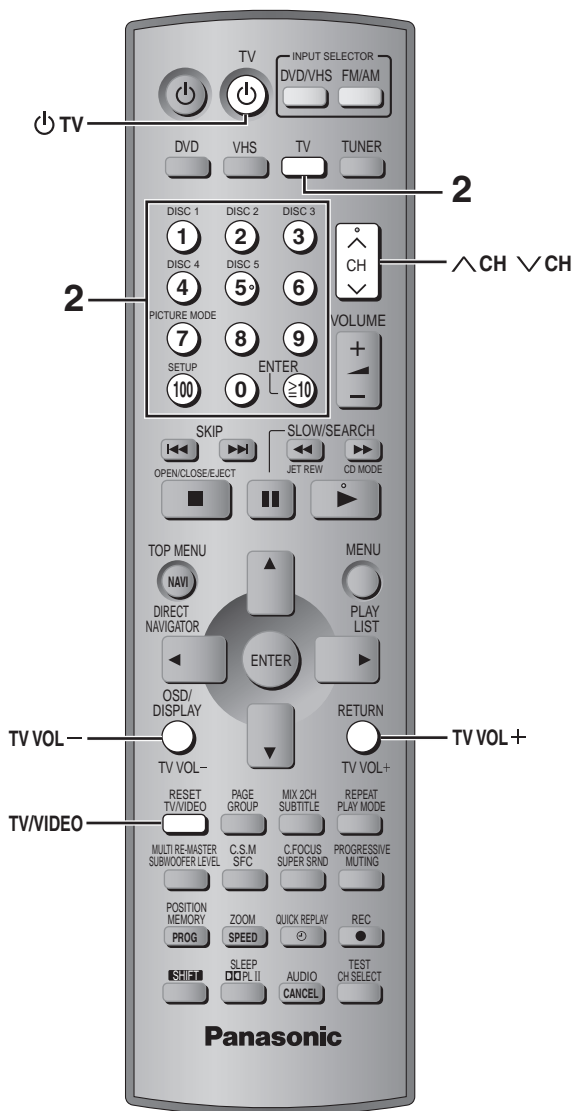

## ■ TV maker setting

You can control the television by entering the remote control code.

**1** Refer the chart below for the code for your television.

**2** Aiming the remote control at the television

While pressing and holding [TV] (  ), press the numbered buttons to enter the code number.

- Example: To select 01, press [0] → [1].
- The remote control outputs the on/off signal. If the code is correct, the equipment turns on or off. If it doesn't, try entering another code.

### Note

- If your television brand is not listed or if the code listed for your television does not allow control of your television, this remote control is not compatible with your television.
- Reenter the codes after you change the batteries.

## ■ TV operation

Operation	Buttons
Power on/standby	[TV]
Remote control TV mode	[TV] • Switch the remote control mode to TV. Press before doing TV operations. When in TV mode, the [TV] button lights each time you press an operation button.
TV/Video switch	[TV/VIDEO]
Selecting channels	[^ CH], [v CH] or numbered buttons [1-9, 100, 0, ≥10/ENTER]. • [≥10/ENTER] is used to confirm channel selection on some televisions manufactured by other companies.
Adjusting volume	[TV VOL-] [TV VOL+]

Manufacturer	Code No.	Manufacturer	Code No.
Panasonic	01, 02	PHILIPS	06
FISHER	14	PIONEER	02, 10, 19
G.E.	02, 03, 07, 09	QUASAR	02
GOLD STAR	07, 15	RCA	03, 07, 09, 13, 23, 24, 25
HITACHI	05, 07	SANYO	14
JVC	12	SHARP	08, 21
LXI	03, 06, 07, 10, 14, 15	SONY	04
MAGNAVOX	06, 07, 11, 15, 22	SYLVANIA	06, 07, 15
MITSUBISHI	07, 15, 16, 21	SYMPHONIC	17
NEC	07, 15	TOSHIBA	10, 21
PHILCO	06, 07	ZENITH	18, 20



SETUP



Turn on the television and select the appropriate video input for the DVD.

- Put the remote control in DVD mode.**
- Turn on the unit.**
- Select "DVD/CD".**
- Select the disc tray.**
- Open the disc tray and load the disc.**
  - Load double-sided discs so the label for the side you want to play is facing up.
- Close the disc tray.**
  - A disc indicator lights green to show the tray is in the play position.
  - To load discs on the other trays, repeat steps 4–6.
- Start play.**
- Adjust the volume.**

--dB 0dB  
(Minimum) (Maximum)



**Progressive video**

SHIFT + PROGRESSIVE MUTING

**Stop**

OPEN/CLOSE/EJECT

The position is memorized when " " flashes on the display.

- Press [▶] (play) to resume.
- DVD-V** To review the previous chapters (→ page 22, Position memory)
- Press [■] to clear the position.

**Pause**

Press [▶] (play) to start play.

**Search (during play)**

Up to 5 steps

Press [▶] (play) to start play.

**Slow-motion (during pause)**

SLOW/SEARCH

- VCD** Slow motion, forward direction only

**Frame-by-frame (during pause)**

- VCD** forward direction only

**Skip**

SKIP

**(Group skip)**

WMA MP3 JPEG

**(Content skip)**

WMA MP3 JPEG

**On-screen item select**

Select

Register

**Enter number**

RAM DVD-A DVD-V VCD CD

e.g. To select 12:  
[≥10] → [1] → [2]

**VCD** with playback control (PBC)

To cancel the playback control, press [■] and then press the numbered buttons.

WMA MP3 JPEG

e.g. To select 123:  
[1] → [2] → [3] → [ENTER]

- Press [CANCEL] to cancel the number(s).

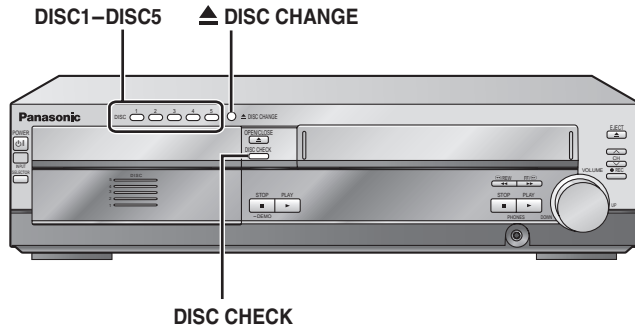
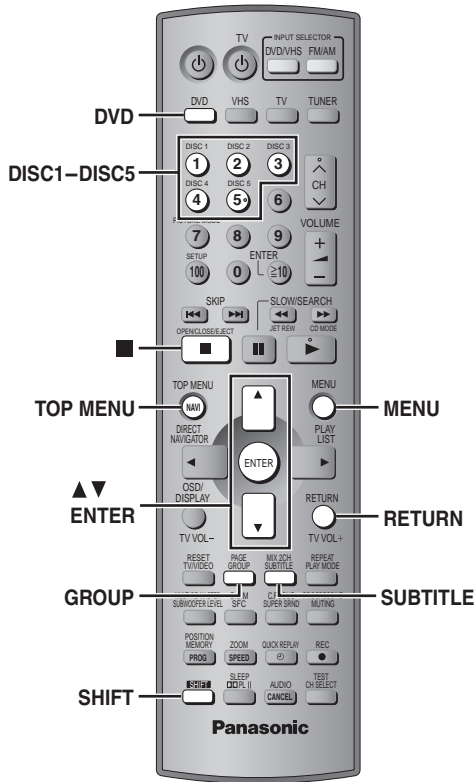

**Disc menu**

- TOP MENU** (DVD-A DVD-V) Shows a disc top menu
- MENU** (DVD-V) Shows a disc menu
- RETURN** (VCD) Shows a disc menu

**Return to previous screen**

- RETURN**

**Information screen**

- MIX 2CH SUBTITLE** (WMA MP3 JPEG) Turns the information screen on/off

**Starting play from a selected group (while stopped)**

**DVD-A WMA MP3 JPEG**  
A folder on WMA/MP3 and JPEG discs is treated as a "Group".

**Selecting the disc directly**

**SHIFT** + [1-5]

- You can select the disc with [DISC1-5] on the main unit.

**Checking the disc trays**

**(Main unit)**  
**DISC CHECK**

- All trays except the tray in play open without interrupting play. While stopped, all trays will open.
- Press [DISC CHECK] again to close the trays.
- Do not pull out the trays, remove, or insert discs during the disc check.

**Changing the discs during play**

**(Main unit)**  
**DISC CHANGE**

- You can change the other discs without interrupting play.
- After selecting the disc tray, press [DISC CHANGE] to close the tray.

**Note**  
Discs continue to rotate while menus are displayed. Press [■] when you finish to preserve the unit's motor and your television screen.

If you are experiencing problems, refer to troubleshooting (→ pages 52-54).

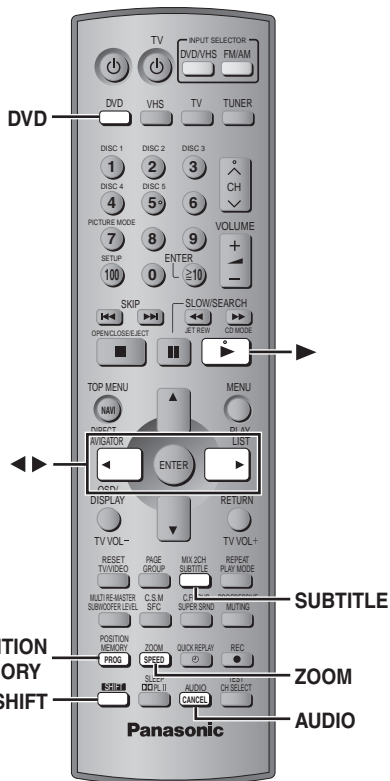

**Position memory**

Memorizes the position to resume play.



**Zoom**

Expands the letterbox picture to fit the screen.



**Subtitle**

Changes the subtitle language.

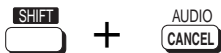

**Audio**

Changes the soundtrack.

See below for details.



DVD

**Position memory**

(Only when the elapsed play time can be displayed)  
**JPEG**: Works with all JPEG content  
 This position is memorized even after turning off the unit, changing the source or moving the disc out of the play position.

**Press [POSITION MEMORY].**



- Up to 5 discs.
- When the sixth disc is memorized, the earliest position is replaced.
- You cannot recall the position in CD Mode (→ page 23).

When the unit is turned on, "DVD/CD" is reselected or the disc comes to the play position,

**Press [▶] (play) to start play from that position.**

**To review the previous chapters DVD-V**  
 Press [▶] (play) while the following message is displayed.



Do not press [▶] (play) if you want to cancel review.

**Zoom**

**RAM DVD-V VCD**

**Press [ZOOM] several times to select the preset aspect ratio or "Auto". (Just Fit Zoom)**

**Fine adjustments (Manual Zoom)**  
 Press [◀▶].

- from ×1.00 to ×1.60 (in 0.01 units)
- from ×1.60 to ×2.00 (in 0.02 units)

• Press and hold [◀▶] to alter faster (in 0.05 units).



**Subtitle**

**DVD-V** (with multiple subtitles) **VCD** (SVCD only)

**RAM** (On/Off only)

**Press [SUBTITLE] several times to select the subtitle language.**

**To clear/display the subtitles**  
 Press [◀▶] to select "On" or "Off".



**Audio**

**DVD-A DVD-V** (with multiple soundtracks) **RAM VCD**

**Press [SHIFT] + [AUDIO] several times to select the soundtrack.**

**RAM VCD**  
 You can use this button to select "L", "R" or "LR".

**DVD-V** (Karaoke discs)  
 Press [◀▶] to select "On" or "Off" of vocals.  
 Read the discs instructions for details.



**Signal type/data**

LPCM/PPCM/Digital/DTS/MPEG: Signal type  
 kHz (Sampling frequency)/bit/ch (Number of channels)

Example:  
 3/2 .1ch

.1: Low frequency effect (not displayed if there is no signal)
0: No surround
1: Mono surround
2: Stereo surround (left/right)
1: Center
2: Front left+Front right
3: Front left+Front right+Center

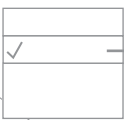

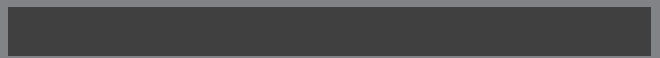
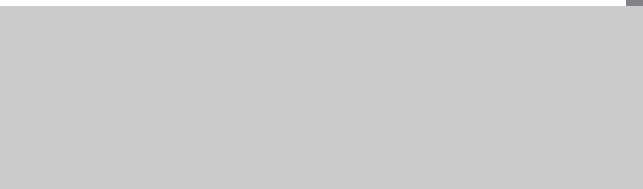

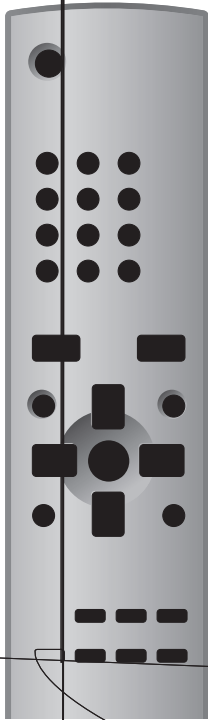

## Repeat play

See below for details.

**VCD** **CD**

- 1-DISC (RND): You can play all the items on a disc in the play position in random order.  
A-DISC (ALL RND): You can play all the items on all the discs in random order.

**DVD-A** **DVD-V** **WMA** **MP3** **JPEG**

You can play selected item(s) on a disc in the play position in random order.

**1**

**DVD-A** **DVD-V** **WMA** **MP3** **JPEG**

**Press the numbered buttons to select a group (WMA MP3 JPEG) then press [ENTER] or a title.**

**DVD-A**

- To enter all groups, press [◀ ▶] to select "All" and press [ENTER].
- To deselect a group, press the numbered buttons corresponding to the group you want to clear.

**2** Press [▶] (play).

(Only when the elapsed play time can be displayed)  
**JPEG**: Works with all JPEG content.)

**During play**

**Press [SHIFT] + [REPEAT] several times to select an item to be repeated.**

**RAM**

PG REPEAT → ALL REPEAT (Entire disc) → REPEAT OFF  
• During play list play  
SCENE REPEAT → PLAY REPEAT → REPEAT OFF

**DVD-A**

TRACK REPEAT → GROUP REPEAT\* → REPEAT OFF

**DVD-V**

CHAPTER REPEAT → TITLE REPEAT\* → REPEAT OFF

**VCD** **CD** (There is no on-screen display.)

TRACK REPEAT → ALL REPEAT (Entire disc) → REPEAT OFF

**WMA** **MP3** (There is no on-screen display.)

CONTENT REPEAT → GROUP REPEAT\* → REPEAT OFF

**JPEG** (There is no on-screen display.)

GROUP REPEAT\* → REPEAT OFF

\* During all group (**DVD-A**), program and random play "ALL REPEAT" is displayed.

# Using navigation menus

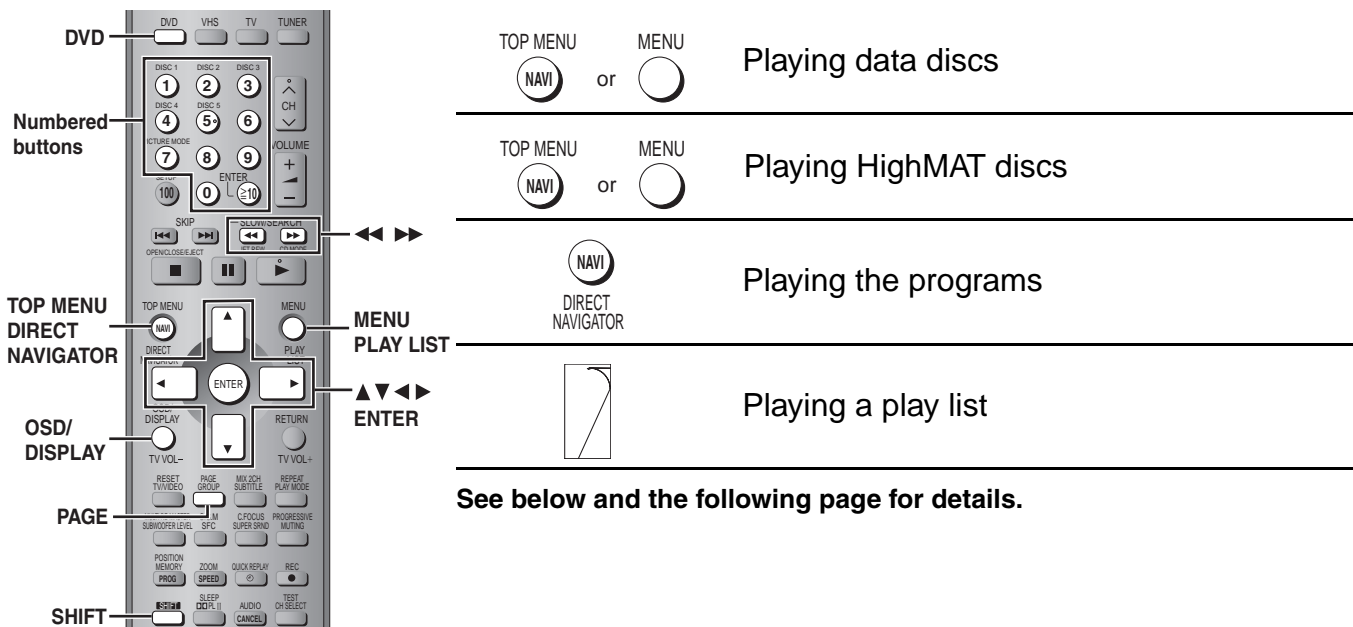

See below and the following page for details.



DVD

**WMA MP3 JPEG**

You can play JPEG files on DVD-RAM or play HighMAT discs without using the HighMAT function (→ page 29, “Play as Data Disc” in Other Menu).

■ **Using playback menus** (except JPEG files on DVD-RAM)

- 1 Press [TOP MENU].
- 2 Press [▲ ▼] to select “All”, “Audio” or “Picture” and press [ENTER].

•To exit the screen  
Press [TOP MENU].

■ **Using navigation menus**

- 1 Press [MENU].
- 2 Press [▲ ▼ ◀ ▶] to select the group or audio/picture content and press [ENTER].

•To enjoy listening to WMA/MP3 contents while showing a JPEG image on the screen

Select a JPEG file first, and then select tracks.  
(The opposite order is not effective.)

•To exit the screen  
Press [MENU].

- 1 Press [TOP MENU] or [MENU].
- 2 Press [▲ ▼] to move through the tracks and press [ENTER].

•Press [SHIFT]+[PAGE] to skip 10 at a time.

- 1 While the menu is displayed  
Press [OSD/DISPLAY].  
Items shown differ depending on the type of software.

- 2 Press [▲ ▼] to select the submenu and press [ENTER].

## Playing HighMAT discs

WMA MP3 JPEG

- 1 Press [TOP MENU].
- 2 Press [ $\blacktriangle$   $\blacktriangledown$   $\blacktriangleleft$   $\blacktriangleright$ ] to select the item following the on-screen instructions.

e.g. Menu: Takes you to the next menu which shows play lists or another menu

Play list: Play starts

- To change the menu background Press [OSD/DISPLAY]. The background changes to the one recorded on the disc.

### ■ Selecting from the list

- 1 During play Press [MENU].
- 2 Press [ $\blacktriangleleft$ ] then [ $\blacktriangle$   $\blacktriangledown$ ] to switch among Playlist, Group and Content lists.
- 3 Press [ $\blacktriangleright$ ] then [ $\blacktriangle$   $\blacktriangledown$ ] to select an item and press [ENTER].



- Press [SHIFT]+[PAGE] to skip 10 at a time.
- To exit the screen Press [MENU].

## Playing the programs

RAM

- 1 Press [DIRECT NAVIGATOR].
  - Titles appear only if you have entered them.
  - You cannot change program and disc titles.
- 2 Press [ $\blacktriangle$   $\blacktriangledown$ ] or the numbered buttons to select the program.
  - Press [SHIFT]+[PAGE] to skip 5 at a time.
  - To select a 2-digit number e.g. 23: [ $\geq 10$ ]  $\rightarrow$  [2]  $\rightarrow$  [3]
  - Press [ $\blacktriangleright$ ] to show the contents of the program.
- 3 Press [ENTER].

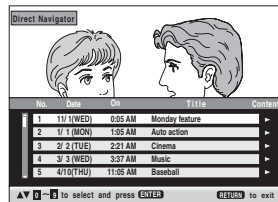

## Playing a play list

RAM

(Only when the disc contains a play list)

- 1 Press [PLAY LIST].
- 2 Press [ $\blacktriangle$   $\blacktriangledown$ ] or the numbered buttons to select the play list.
  - Press [SHIFT]+[PAGE] to skip 10 at a time.
  - To select a 2-digit number e.g. 23: [ $\geq 10$ ]  $\rightarrow$  [2]  $\rightarrow$  [3]
- 3 Press [ENTER].

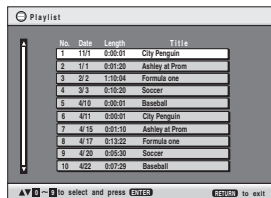

### Tips for making WMA/MP3 and JPEG discs (For CD-R/CD-RW)

- Discs must conform to ISO9660 level 1 or 2 (except for extended formats).
- This unit is compatible with multi-session but if there are a lot of sessions it takes more time for play to start. Keep the number of sessions to a minimum to avoid this.

### Naming folders and files

At the time of recording, prefix folder and file names with 3-digit numbers in the order you want to play them (this may not work at times).

Files must have the extension:

- ".WMA" or ".wma"
- ".MP3" or ".mp3"
- ".JPG", ".jpg", ".JPEG" or ".jpeg"

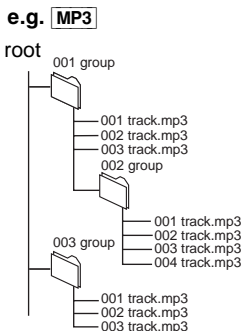

WMA

- You cannot play WMA files that are copy protected.

MP3

- This unit is not compatible with ID3 tags.
- Compatible sampling rate: 8, 11.02, 12, 16, 22.05, 24, 32, 44.1 and 48 kHz.

JPEG

- To view JPEG files on this unit:
  - Take them on a digital camera that meets the DCF Standard (Design rule for Camera File system) Version 1.0. Some digital cameras have functions that are not supported by the DCF Standard Version 1.0 like automatic picture rotation which may render a picture un-viewable.
  - Do not alter the files in any way or save them under a different name.
- This unit cannot display moving pictures, MOTION JPEG and other such formats, still pictures other than JPEG (e.g. TIFF) or play associated sound.



Windows Media, and the Windows logo are trademarks, or registered trademarks of Microsoft Corporation in the United States and/or other countries.



WMA is a compression format developed by Microsoft Corporation. It achieves the same sound quality as MP3 with a file size that is smaller than that of MP3.

MPEG Layer-3 audio decoding technology licensed from Fraunhofer IIS and Thomson multimedia.

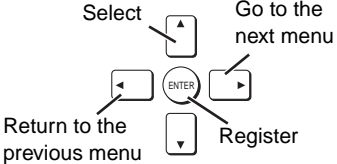
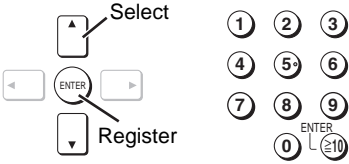
Refer to page 7 for remote control button positions.

<p><b>1</b></p>  <p>Press once. (When pressed twice, the elapsed play time indicator appears. → below)</p>	<p><b>2</b></p>  <p>Select the menu.</p>	<p><b>3</b></p>  <p>Make the settings.</p>	<p><b>4</b></p>  <p>Press to exit.</p>
---	---	--	---

Items shown differ depending on the type of software.

## Main menus

<b>Program Group</b>	To start from a specific item
<b>Title</b>	
<b>Chapter</b>	
<b>Track</b>	
<b>Playlist</b>	
<b>Content</b>	
<b>Time</b>	<p>To skip incrementally or decrementally (Time Slip)</p> <p>1 Press [ENTER] twice to show Time Slip indicator.</p> <p>2 Press [▲ ▼] to enter the time and press [ENTER].</p> <p>• Press and hold [▲ ▼] to alter faster.</p> <p>To start from a specific time (Time Search)</p> <p>To change remaining/elapsed time display</p>
<b>Audio</b>	(→ page 22)
	To display the current bitrate or sampling frequency

<b>Still Picture</b>	To switch still picture
<b>Thumbnail</b>	To show thumbnail images
<b>Subtitle</b>	(→ page 22)
<b>Marker(VR)</b>	<p>To recall a marker recorded on DVD-Video recorders</p> <p>To recall a marker: [▲ ▼] → [ENTER]</p>
<b>Angle</b>	<p>(with multiple angles)</p> <p>To select the angle</p>
<b>Rotate Picture</b>	To rotate pictures
<b>Slideshow</b>	<p>To turn on/off slideshow</p> <p>To change the slideshow timing (0–30 sec)</p>



DVD

**■ Elapsed play time indicator**

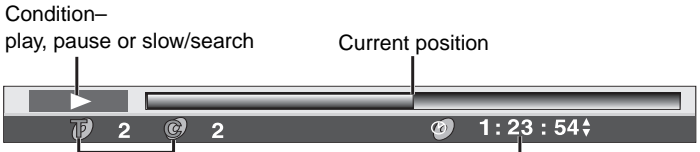

Condition—play, pause or slow/search

Current position

Current playback item

Press [▲ ▼] to select the elapsed play time or the remaining time. (except **JPEG**)

## Other settings

Play Speed	<b>RAM DVD-V</b> To change play speed –from ×0.6 to ×1.4 (in 0.1 units)
	<ul style="list-style-type: none"> <li>• After you change the speed           <ul style="list-style-type: none"> <li>–Output is in stereo.</li> <li>–Sampling frequency of 96 kHz is converted to 48 kHz.</li> </ul> </li> </ul>

## ■ Play Menu

(Only when the elapsed play time can be displayed)

**JPEG**: Works with all JPEG content.)

Repeat	(→ page 25)
A-B Repeat	Except <b>JPEG</b> <b>RAM</b> (still picture part) To repeat a specified section Press [ENTER] at the starting and ending points. Press [ENTER] again to cancel.
Marker	To mark up to 5 positions to play again Press [ENTER] (The unit is now ready to accept markers.) To mark a position: [ENTER] (at the desired point) To mark another position: [◀▶] → [ENTER] To recall a marker: [◀▶] → [ENTER] To erase a marker: [◀▶] → [CANCEL] • This feature doesn't work during program and random play.

## ■ Picture Menu

Picture Mode	<b>Normal</b> <b>Cinema1</b> : Mellows images and enhances detail in dark scenes. <b>Cinema2</b> : Sharpens images and enhances detail in dark scenes. <b>Animation</b> <b>Dynamic</b> <b>User</b> (Press [ENTER] to select "Picture Adjustment") (→ below)
	<b>Picture Adjustment</b> <b>Contrast Brightness Sharpness Color Gamma</b> (Adjusts the brightness of dark parts.) <b>Depth Enhancer</b> Reduce the rough noise in the background to give a greater feeling of depth. <ul style="list-style-type: none"> <li>• This does not work while using Cinema1 or Cinema2 (→ above).</li> </ul>
Video Output Mode	480I (Interlace) ↔ 480P (Progressive)
Transfer Mode	If you have chosen "480P" (→ above), select the method of conversion for progressive output to suit the type of material. <b>Auto1</b> (normal): For viewing film material <b>Auto2</b> : For viewing film material (the same as Auto1, but able to convert 30-frame-per-second progressive video) <b>Video</b> : For video material

## ■ Audio Menu

Dolby Pro Logic II	(→ page 46)
Dialogue Enhancer	To make the dialogue in movies easier to hear <b>DVD-V</b> (Dolby Digital, DTS, MPEG, 3-channel or over, with the dialogue recorded in the center channel) <b>On</b> ↔ <b>Off</b>
Multi Re-master	(→ page 23)

## ■ Display Menu

Information	On ↔ Off ( <b>JPEG</b> : Off, Date, Details)
Subtitle Position	0 to –60 (in 2 units)
Subtitle Brightness	Auto, 0 to –7
4:3 Aspect	To select how to show images made for 4:3 aspect screens on a 16:9 aspect television <b>Normal</b> : Laterally stretches images. <b>Auto</b> : Expands 4:3 letterbox images to fill more of the screen. Other images appear in full in the center of the screen. <b>Shrink</b> : Images appear in the center of the screen. <b>Zoom</b> : Expands all images fill the screen. If your television has a similar feature, use it instead for a better effect.
Just Fit Zoom	(→ page 22)
Manual Zoom	(→ page 22)
Bitrate Display	<b>RAM DVD-V VCD</b> On ↔ Off
GUI See-through	On ↔ Off
GUI Brightness	–3 to +3



## ■ Other Menu

Play as DVD-Video or Play as DVD-Audio	While stopped <ul style="list-style-type: none"> <li>• Select "Play as DVD-Video" to play DVD-Video contents on DVD-Audio.</li> </ul>
Play as DVD-VR Play as HighMAT or Play as Data Disc	While stopped <ul style="list-style-type: none"> <li>• Select "Play as Data Disc" to play JPEG files on DVD-RAM or to play HighMAT disc without using the HighMAT function.</li> </ul>

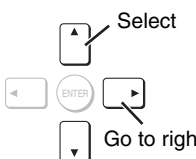
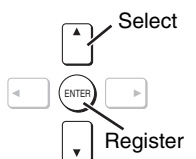
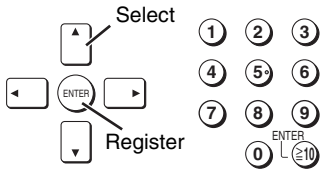

DVD

Refer to page 7 for remote control button positions.

<p><b>1</b></p>  <p>Shows Setup menu.</p>	<p><b>2</b></p>  <p>Select the tab.</p>	<p><b>3</b></p>  <p>Select the item.</p>	<p><b>4</b></p>  <p>Make the settings.</p>	<p><b>5</b></p>  <p>Press to exit.</p>
--	--	---	--	---

- The settings remain intact even if you switch the unit to standby.
- Underlined items are the factory preset.

The QUICK SETUP enables successive settings of the items in the shaded area.

**■ “Disc” tab**

<b>Audio</b> Choose the audio language.	<ul style="list-style-type: none"> <li>• <u>English</u>    • French    • Spanish    • Original*<sup>1</sup>    • Other*<sup>*</sup>*<sup>*</sup>*<sup>*</sup>*<sup>2</sup></li> </ul>
<b>Subtitle</b> Choose the subtitle language.	<ul style="list-style-type: none"> <li>• <u>Automatic</u>*<sup>3</sup>    • English    • French    • Spanish    • Other*<sup>*</sup>*<sup>*</sup>*<sup>*</sup>*<sup>2</sup></li> </ul>
<b>Menus</b> Choose the language for disc menus.	<ul style="list-style-type: none"> <li>• <u>English</u>    • French    • Spanish    • Other*<sup>*</sup>*<sup>*</sup>*<sup>*</sup>*<sup>2</sup></li> </ul> <p>Changing the menu language from QUICK SETUP</p>
<b>Ratings</b> Set a ratings level to limit DVD-Video play. • Follow the on-screen instructions.	<p>Setting ratings (When level 8 is selected)</p> <ul style="list-style-type: none"> <li>• <u>8 No Limit</u>: All DVD-Video can be played.</li> <li>• 1 to 7    • 0 Lock All: To prevent play</li> </ul> <p>Changing ratings (When level 0–7 is selected)</p> <ul style="list-style-type: none"> <li>• <u>Unlock Player</u>    • Change Parental Lock</li> <li>• <u>Change Level</u>    • Temporary Lock</li> </ul>

\*<sup>1</sup> The original language designed on the disc is selected.  
 \*<sup>2</sup> Input a code number referring to the table on page 31.  
 \*<sup>3</sup> If the language selected for “Audio” is not available, subtitle appears in that language.

**■ “Video” tab**

<b>TV Aspect</b> Choose the setting to suit your television and preference.	<ul style="list-style-type: none"> <li>• <u>4:3 Pan&amp;Scan</u>: Regular aspect television. The sides of the widescreen picture are prohibited by the disc).</li> <li>• 4:3 Letterbox: Regular aspect television. Widescreen picture is shown in the letterbox.</li> <li>• 16:9: Widescreen television (Full Screen)</li> </ul>
<b>TV Type</b> Select to suit the type of television.	<ul style="list-style-type: none"> <li>• <u>Standard (Direct View TV)</u></li> <li>• CRT Projector</li> <li>• Projection TV</li> </ul>
<b>Time Delay</b> When connected to a Plasma display, adjust if you notice the audio is out of the sync with the video.	<ul style="list-style-type: none"> <li>• <u>0ms</u>    • 20ms</li> </ul>
<b>Still Mode</b> Specify the type of picture shown when paused.	<ul style="list-style-type: none"> <li>• <u>Automatic</u></li> <li>• Freeze</li> <li>• Still</li> </ul>
<b>Black Level Control</b> Change the black level of the picture when you connected a television through the COMPONENT VIDEO OUTPUT terminals.	<ul style="list-style-type: none"> <li>• <u>Normal</u></li> <li>• Light</li> <li>• Dark</li> </ul>

**■ “Audio” tab**

<b>Dynamic Range</b> Choose the dynamic range setting.	<ul style="list-style-type: none"> <li>• <u>Normal</u></li> <li>• Loud</li> <li>• Quiet</li> </ul>
<b>Audio</b> Select the audio format.	<ul style="list-style-type: none"> <li>• <u>Auto</u></li> <li>• DTS</li> <li>• Dolby Digital</li> <li>• PCM</li> </ul>
<b>Subtitles</b> Select the subtitle format.	<ul style="list-style-type: none"> <li>• <u>Auto</u></li> <li>• On</li> <li>• Off</li> </ul>

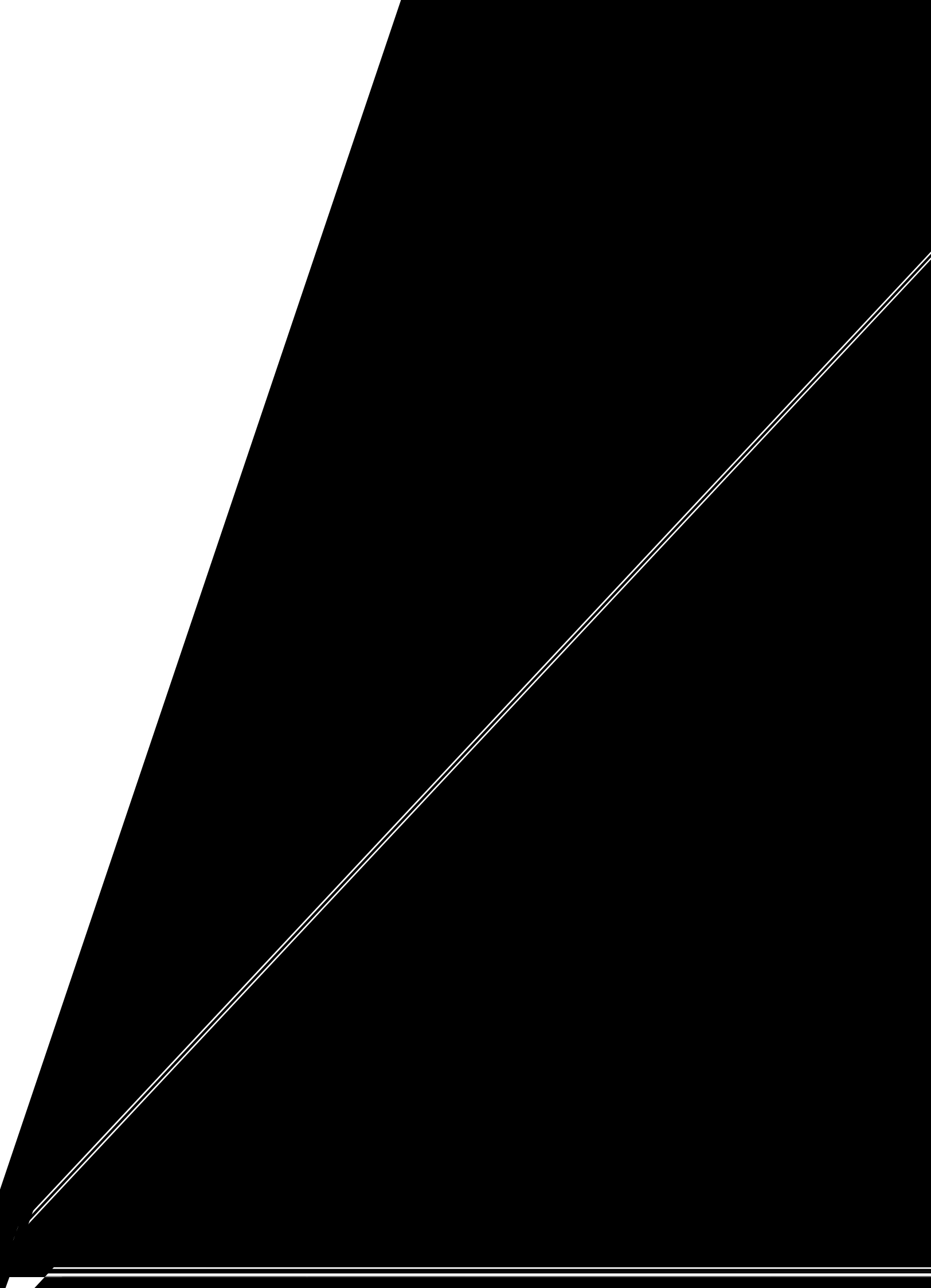

Turn on the television and select the appropriate video input for the VHS.

**1 Put the remote control in VHS mode.**



**2 Turn on the unit.**



**3 Select "VHS".**



**4 Insert a tape.**  
Play starts automatically if you insert a pre-recorded tape or one that has had its tab removed.



**5 Start play.**



**6 Adjust the volume.**

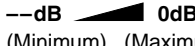

--dB (Minimum) 0dB (Maximum)



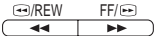





**Press to**  
-fast-forward and rewind  
-cue and review.  
Press twice to Jet search.



**Stop**



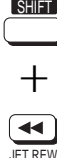

<b>Stop</b>		
<b>Pause</b>		• Press [▶] (play) to start play.
<b>Slow</b>		• There is no sound.
<b>Fast-forward and rewind (while stopped)</b>		• You can use fast-forward and rewind after pressing [VHS] while using another source.
<b>Cue and review (during play)</b>		• There is no sound. • Press and hold during play. Play restarts when you release the button.
<b>Jet search (during play)</b>		• Press [▶] (play) to start play. • There is no sound.
<b>Jet rewind (while stopped)</b>		• The tape counter does not appear. • You can use jet rewind after pressing [VHS] while using another source.
<b>Eject</b>		• You can eject tapes when the unit is in standby mode. It switches back to standby mode once it ejects the tape. • You cannot eject tapes when the unit is recording or in timer recording standby mode.

**Note**

- Pause stops after 5 minutes. Cue, review and jet search restart to play after 10 minutes.
- The tape moves at high speed during fast-forward, rewind, and jet rewind so the unit will make a noise. Also, it takes some time for the tape to stop after you press [■].

- The picture during cue, review, and jet search may be disrupted or otherwise affected on some televisions. During jet search at 35 times normal speed through EP or VP recordings, the picture may scroll vertically on some televisions. Change to 27-times normal speed if this occurs (→ page 42).

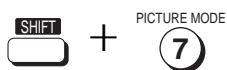
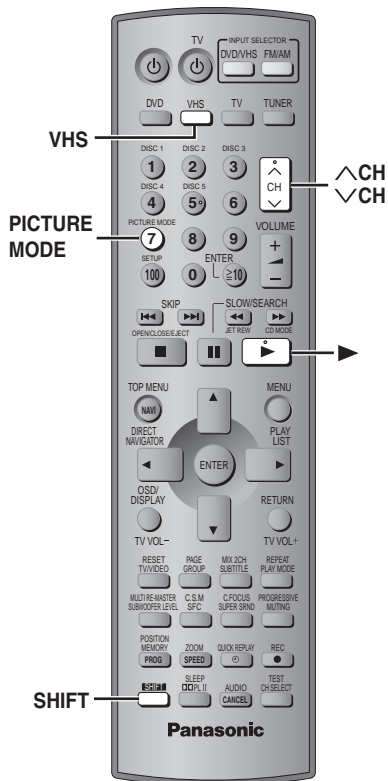

### Picture mode

Changes the picture quality to suit the material you are playing.

Press and hold



### Repeat play

Plays a program repeatedly.



### Manual tracking

Adjusts the tracking manually.



### Vertical locking adjustment

Adjusts the vertical hold to keep the picture from jiggling.

See below for details.



## Picture mode

Press [SHIFT]+ [PICTURE MODE].

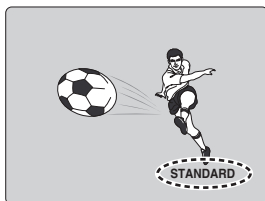

Each time you do this:

**STANDARD:** for recordings of television program (Factory preset)

**DYNAMIC:** Clear, vivid pictures for scenery and sports

**SOFT:** for prerecorded tapes

## Repeat play

Press and hold [▶] (play) for about five seconds.

"R▶" appears on the television.

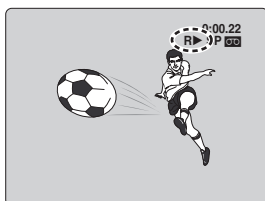

At the end of the program, the tape rewinds to the beginning of the program and plays it again. (It only works if there is a five-second blank at the end of the program.) This repeats until you cancel it.

### To cancel

Press [▶] (play).

• It also cancels if you stop, pause, cue, or review.

## Manual tracking

This unit has an automatic digital tracking control feature that usually makes tracking adjustments for you, but you may need to do it manually, such as if noise appears on a tape recorded on other equipment.

During play

Press [^ CH] or [v CH].

Repeat until the noise disappears.

**To return to automatic digital tracking control**

Press [^ CH] and [v CH] at the same time.

**To remove the noise from a paused picture**

Start slow play, then adjust the tracking.

**Note**

This may not be effective on some tapes.

## Vertical locking adjustment

While paused

Press [^ CH] or [v CH].

Repeat until the jiggling stops.

**To return to the previous condition**

Press [^ CH] and [v CH] at the same time.

**Note**

This may not work with some televisions. Try adjusting the vertical on the television itself.



VHS

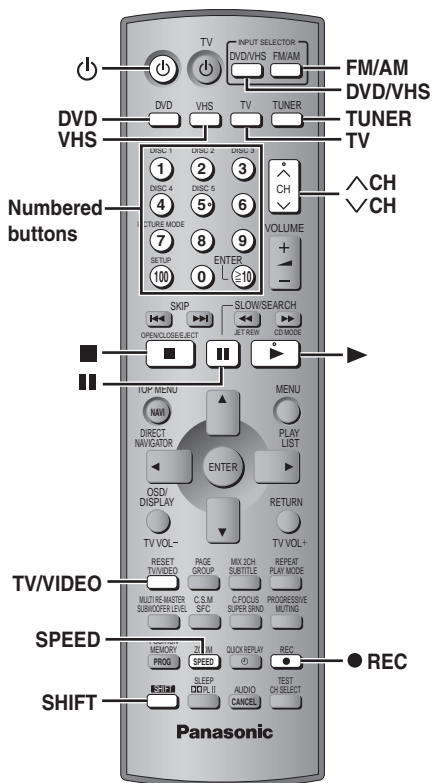

## Preparation

Turn on the television and select the video input for the VHS.

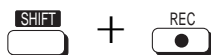

Recording a program

See below for details.



## Recording a program

- 1** Press [VHS] to put the remote control in VHS mode.
- 2** Press [⏻] to turn on the unit.
- 3** Press [DVD/VHS] to select “VHS” as the source.
- 4** Insert the tape you want to record to.  
Ensure its tab is in place (→ page 5).
- 5** Select the channel with the numbered buttons, [^ CH] or [v CH].
  - To select with the numbered buttons:  
e.g. channel 2: [0] → [2]  
channel 23: [2] → [3]  
channel 123: [100] → [2] → [3]
- 6** Press [SPEED] to select the tape speed.  
SP → EP → VP
- 7** Press [SHIFT] + [● REC] to start recording.

“REC” lights on the unit’s display.



### To stop recording

Press [■].

### To pause recording

Press [⏸].

Press it again or press [SHIFT] + [● REC] to continue recording.

### ■ To specify a time to stop recording (→ page 48, Sleep timer)

#### Note

- You cannot change channels while recording. You can change channels while paused.
- The unit will automatically return to the stop mode after a pause of 5 minutes while recording.
- Even if the tape you use is labeled “S-VHS”, the recordings you make do not use this system.
- You cannot record from the disc section to the unit.

### ■ Tape speeds

There are three tape speeds.

**SP:** You can record the length shown on the tape.

**EP:** Three times the length of SP mode.

**VP:** Five times the length of SP mode.

- You cannot play tapes recorded with VP mode on other equipment.
- It takes more time for automatic tracking to work when playing tapes recorded with VP mode, and it may not work at all with some tapes. Do tracking manually if this is the case (→ page 33).
- This unit can play tapes recorded with LP mode on other equipment (“LP” lights on the display).

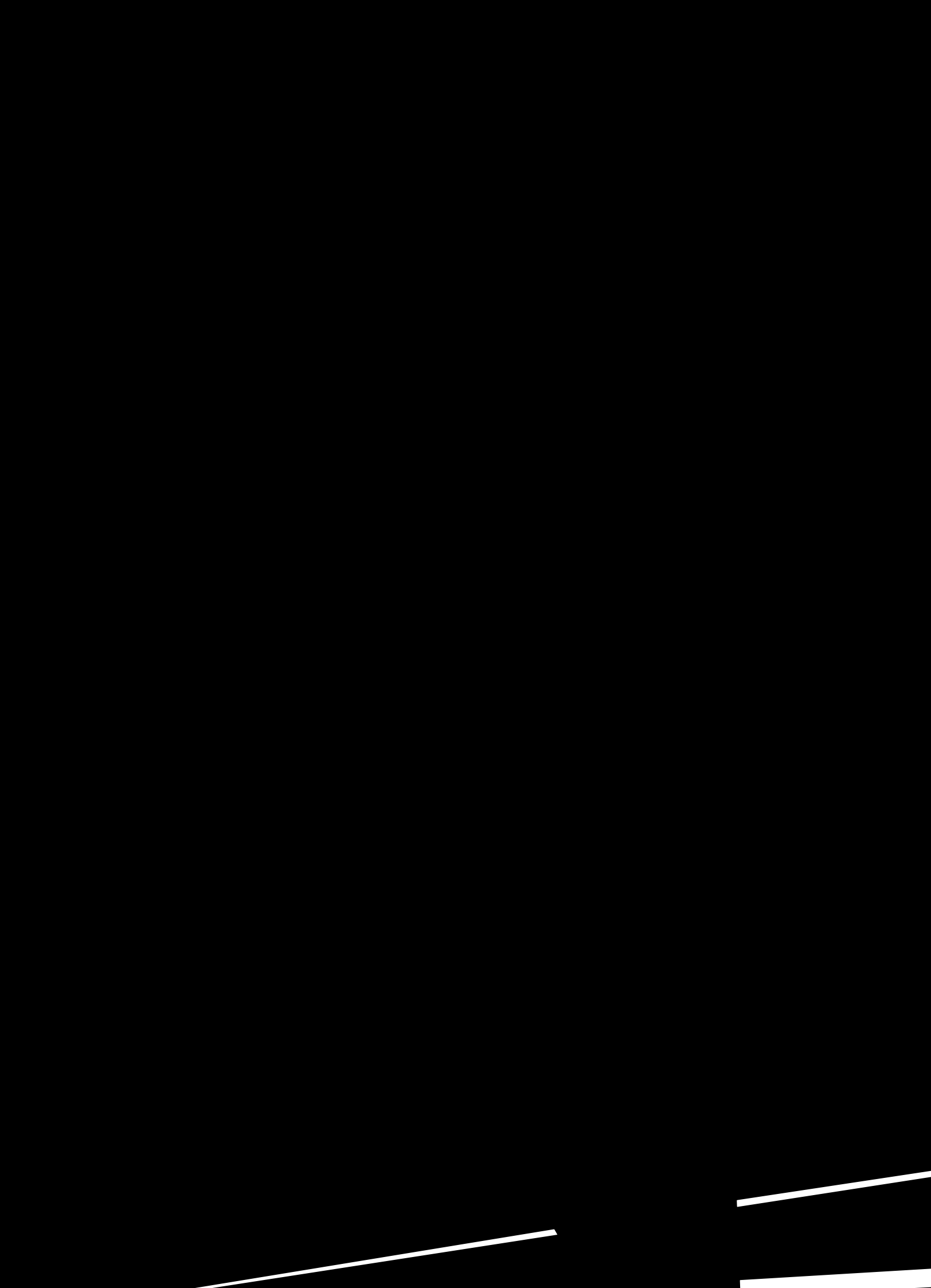

rding programs. You can set the timer to record an individual  
, record at the same time on the same day every week, or at

ect (→ page 40 to adjust it if necessary).  
n place (→ page 5).

## ner recording

---

**38),**

in. Press [▲ ▼] to enter  
elect a category with  
U].  
egory in the navigator list

**r programs.**

**it on timer**

**unit to**

ne unit is on or not, so  
dio (→ page 35). Switch  
l.

---

**standby**

**To check, correct, and cancel timer programs**

**■ To check a program**

Press [PROG].

The timer-programming screen appears.

**■ To correct a program**

While the timer programming screen is on the television,

- 1 Press [PROG] to highlight the program you want to correct and press [ENTER].
- 2 Select the item with [◀ ▶] and correct it with [▲ ▼].

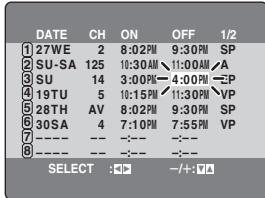

**■ To cancel a program**

While the timer programming screen is on the television,

- 1 Press [PROG] to highlight the program you want to cancel.
- 2 Press [CANCEL].

**To clear the timer programming screen**

Press [MENU].

**Auto SP/EP change**

The unit switches tape speed to EP if it determines there is not enough tape to record the entire program in SP mode. The change may start at the beginning of the recording or part way through, depending on the remaining tape.

Before using this function, set the length of the tape you are using (→ page 42). It may not work correctly if you use tapes with irregular lengths.

Example program combination

1st program (30 min.)	2nd program (60 min.)	
Example program combination		
30 min. at SP	15 min. at SP	45 min. at EP (when using a 60-min. tape)

**Note**

This function does not guarantee recording of the entire program.



VHS

The unit saves the date, channel, time, and category of the recordings you make and shows them on the Jet Navigator list, making it easier to find and play them. It can save the data for up to 14 recordings on a tape, for 20 different tapes, and for a total of 50 recordings.

## Saving Jet Navigator data

## Using the Jet Navigator to find programs

See below for details.

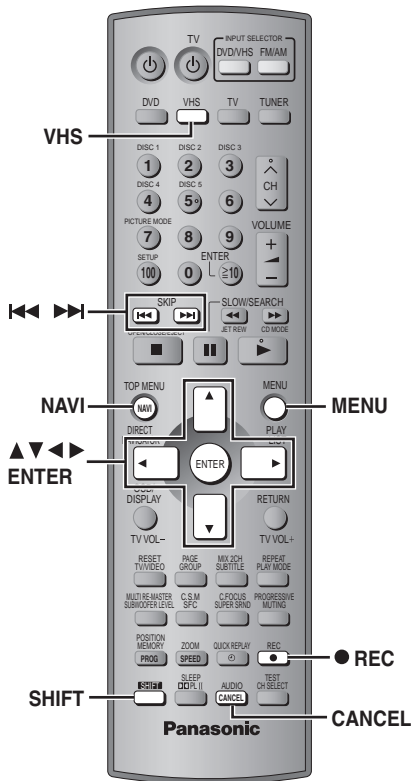

## Saving Jet Navigator data

- 1 Press [MENU] to display the “VHS MENU” screen.
- 2 Press [▲ ▼] to select “OPTION” menu and press [ENTER].
- 3 Press [▲ ▼] to select “JET NAVIGATOR” and press [◀ ▶] to change the setting to “ON”.

	OPTION	1/2
OSD	ON	OFF
TAPE SELECT	T120 T160 T180	
BLUE BACK	ON	OFF
JET NAVIGATOR	ON	OFF
DELETE NAVIDATA	NO	YES
JET SEARCH	x27 x35	
SELECT	:MENU	-/+:
END		

- 4 Press [▲ ▼] to select “TAPE SELECT” and press [◀ ▶] to set the length of the tape you are using.  
T120: T30, T60, T90, T120 tapes  
T160: T140, T160 tapes  
T180: T180 tapes
- 5 Record programs (→ pages 34–36).  
The unit makes the list as you record.

**To exit the settings screen**  
Press [MENU] until the screen disappears.

- 1 Press [NAVI] to show the “JET NAVIGATOR” screen.
- 2 Press [NAVI] to highlight the program you want to watch.  
The most recent program is highlighted first.

Once you have highlighted the program, wait about three seconds. The unit then starts searching for the program and starts play.

The channel, date, and time of a recording appear on the television when play starts.

**To clear the Jet Navigator list**  
Press [MENU].

■ **To delete the Jet Navigator on a video cassette tape**

Keep [CANCEL] pressed for more than 5 seconds while the Jet Navigator list appears. “- -” appears on the list.

■ **To delete all the Jet Navigator data stored in the unit’s memory (→ page 42).**

### Setting categories

Set categories to make it easier to see what kind of programs are in the list.

- 1 Press [▶] (cursor) while the program you want to categorize is highlighted.
- 2 Press [▲ ▼ ◀ ▶] to select a category and press [MENU] to confirm and return to the previous screen.

Category	Indication	Icon
Movie	MOVIE	
Music	MUSIC	
Drama	DRAMA	
Education	EDUCA	
Documentary	DOCUM	
Sports	SPORT	
Children	CHILD	
News	NEWS	
Others	OTHER	

#### To return to the Jet Navigator list

Press [MENU].

#### Note

- If you have already stored 14 programs on a tape and you then store another one, the new item is added and the oldest is deleted.
- "REMAINING PROGRAM 0 DELETE JET NAVIGATOR DATA" appears when you try to store more than fifty programs. The new item is added and the oldest item is deleted.
- "REMAINING CASSETTE 0 FOR JET NAVIGATOR DATA" appears when you try to store items for more than 20 tapes. Delete all the Jet Navigator data in the unit if you want to save the data for the tape (→ page 42).
- The list does not appear when playing tapes recorded on other equipment.
- Parts of the list data are recorded on the tape. Take care when recording over older recordings that you do not overlap it. It is recorded within a few minutes either side of the beginning of the recording (longer if you used EP or VP).

#### To demonstrate the Jet navigator function

Keep [NAVI] pressed for more than 5 seconds without inserting a cassette tape.

### Finding programs—VHS Index Search System (VISS)

Use the index marks on a tape to find sections to play. The unit adds index marks when recording starts. To add them manually during recording, press [SHIFT]+[● REC].

While stopped or during play

Press [◀◀] (backward) or [▶▶] (forward) to skip to the part you want to play.

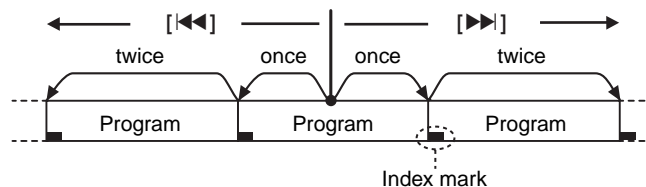

The channel, date, and time of a recording appear on the television when play restarts.

- Up to 20 index signals can be searched for in both directions.
- You can reduce the number of skips by pressing the opposite button.
- This feature may not work correctly if the marks are too close together. Make recordings of at least 15 minutes (25 minutes in VP mode).



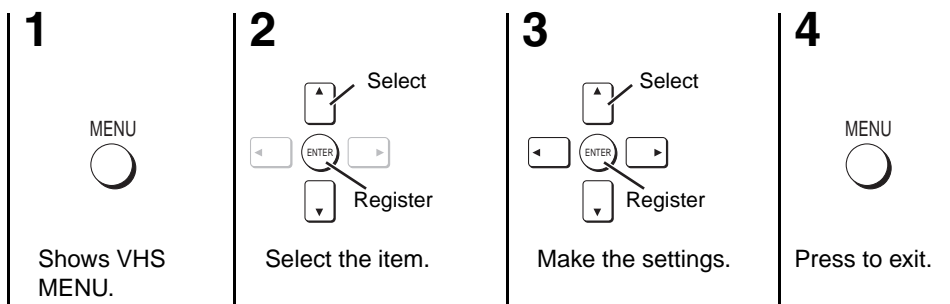
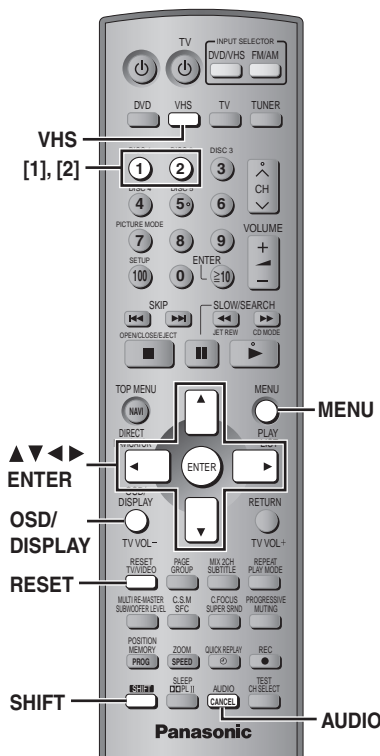

• The settings remain intact even if you switch the unit to standby.

See below and the following pages for details (while VHS MENU is displayed).

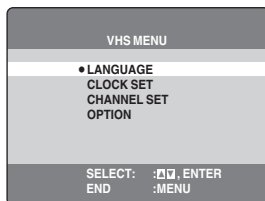

## LANGUAGE

Select the language for these menus and other on screen displays.

- Press [▲ ▼] to select "LANGUAGE" and press [ENTER].
- Press [▲ ▼] to choose the preferred language.
  - ENGLISH (Factory preset)
  - ESPAÑOL
  - FRANÇAIS

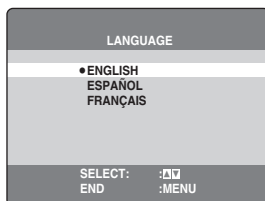

Press [MENU] to confirm and return to the previous screen.

## CLOCK SET

The clock is set automatically after Plug-in Auto Tuning (→ page 17). Do the following if you want to set it again or if the time is not set correctly.

- Press [▲ ▼] to select "CLOCK SET" and press [ENTER].

### AUTO CLOCK SET

- Press [▲ ▼] to select "AUTO CLOCK SET" and press [ENTER].

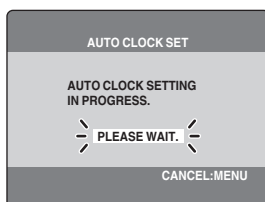

Auto setting starts. This can take some time.

To stop partway through Press [MENU].

### ■ If the unit cannot set the clock automatically

The MANUAL CLOCK SET screen appears. Set the time manually (→ below).

### MANUAL CLOCK SET

- Press [▲ ▼] to select "MANUAL CLOCK SET" and press [ENTER].
- Press [◀ ▶] to select the item you want to change and press [▲ ▼] to change the setting.
  - D.S.T.: Daylight Saving Time
- Press [MENU] to start the clock and exit the setting screen.

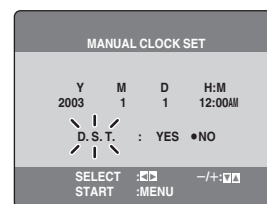

### ■ Time reset function

To return the clock to the exact hour, wait until the clock in the MANUAL CLOCK SET screen is within 2 minutes either side of the hour (e.g., between 11:58:00 and 12:01:59) press [MENU] to clear the screen. The clock changes to the exact hour.



Refer to the remote control illustration on page 40.

## OPTION

- 1 While VHS MENU is displayed (→ page 40)  
Press [**▲ ▼**] to select the “**OPTION**” and press [**ENTER**].
- 2 Press [**▲ ▼**] to select the item and press [**◀ ▶**] to change the setting (→ below).

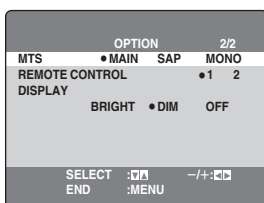
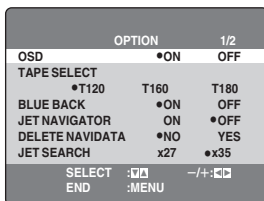

### To exit the settings screen

Press [MENU] until the screen disappears.

## REMOTE CONTROL

Panasonic video cassette recorders use the same remote control system so they may respond unintentionally to a command from this remote control. Change the code on this unit and its remote control (the two must match) if you place another Panasonic video cassette recorder close together.

- Use “1”, the factory preset, under normal circumstances.

- 1 While OPTION menu is displayed  
Press [**▲ ▼**] to select the “**REMOTE CONTROL**”.
- 2 Press [**◀ ▶**] to select the code (1 or 2) and press [MENU].  
The remote control code on the unit has been set.
- 3 While pressing [ENTER] on the remote control, press and hold the numbered button ([1] or [2]) corresponding to the code you selected in step 2.  
The remote control code on the remote control has been set.

The following is displayed when you use a remote control with the different code.



The unit's remote control code

Change its code to match the unit's (→ step 3).



VHS

Items	Settings (Underlined items are the factory preset.)
<b>OSD</b> (→ page 43, On-screen display)	<u>ON</u> : Messages appear on the television for about five seconds after you perform operations. OFF: Messages do not appear.
<b>TAPE SELECT</b> Set the length of tape you are using so the unit can show the correct remaining time.	<u>T120</u> : T30, T60, T90, T120 tapes T160: T140, T160 tapes T180: T180 tapes
<b>BLUE BACK</b>	<u>ON</u> : The screen shows a blue background when you play unrecorded portions. OFF
<b>JET NAVIGATOR</b> (→ page 38)	ON: Jet Navigator data automatically registered. <u>OFF</u> : Data not registered.
<b>DELETE NAVIDATA</b> Delete all the Navigation data registered in the unit. See page 38 to delete data on a single tape.	<u>NO</u> YES: Then press [ENTER] when you want to delete all the Jet navigator data.
<b>JET SEARCH</b> (→ page 32) Set the speed for JET SEARCH when playing EP and VP tapes.	×27 <u>×35</u> Select ×27 if the picture is poor at ×35.
<b>MTS</b> (→ page 43, Changing audio) Set the MTS (Multi-channel Television Sound Stereo) reception type.	<u>MAIN</u> : To receive stereo broadcasts. SAP: To receive SAP when being broadcast. MONO: To receive monaural broadcasts (e.g., when reception is poor).
<b>REMOTE CONTROL</b>	1 2
<b>DISPLAY</b> Set the brightness of the unit's display when the unit is in standby mode.	BRIGHT: The display is bright all the time. <u>DIM</u> : The display dims when the unit is in standby mode. OFF: The display turns off when the unit is in standby mode. •When Demo function is on, the display does not turn off even if “OFF” is selected. Select “DEMO OFF” to reduce power consumption (→ page 16).



# The radio

Press [TUNER] to put the remote control in TUNER mode.



Up to 15 stations can each be set in the FM and AM bands.

- 1 Press [FM/AM] to select “FM”.**
- 2 Press [◀◀] or [▶▶] to tune to the lowest frequency (“FM 87.9” MHz or “FM 87.5” MHz).**
- 3 Press and hold [ENTER].**  
Release the button when “AUTO” is displayed.  
The tuner presets all the stations it can receive into the channels in ascending order.  
•“SET OK” is displayed when the stations are set. The last station to be set is then played.
- 4 Repeat steps 1 to 3 to set the AM bands (the lowest frequency is “AM 520” kHz).**



- 1 Press [FM/AM] to select “FM” or “AM”.**
- 2 Press [◀◀] or [▶▶] to select the frequency.**  
Press and hold [◀◀] or [▶▶] until the frequency starts scrolling to start automatic tuning. Tuning stops when a station is found.
- 1 Tune to the station (→ above).**
- 2 Press [ENTER].**
- 3 While “PGM” is flashing on the display Press the numbered buttons to select a channel.**  
Alternatively, press [^ CH] or [v CH] then press [ENTER].

- 1 Press [FM/AM] to select “FM” or “AM”.**
- 2 Press the numbered buttons to select the channel.**

Alternatively, press [^ CH] or [v CH].  
To select a 2-digit number  
e.g. 12: [≥10] → [1] → [2].

When a stereo FM broadcast is being received.

- **If noise is excessive in FM**  
Press [PLAY MODE] to display “MONO”.

Press [PLAY MODE] again to cancel the mode.

The mode is also canceled when you change the frequency.

- **FM frequency step**

#### Main unit only

The step is factory-set to 0.2 MHz, but you can change it to receive broadcasts allocated in 0.1-MHz steps.

- 1 Press [INPUT SELECTOR] on the main unit to select “FM”.
- 2 Press and hold [INPUT SELECTOR].  
After a few seconds the display changes to show the current minimum frequency. Continue to hold the button down. The minimum frequency changes and the step is changed.  
To return to the original step, repeat the above steps.

#### **Note**

Any FM/AM frequencies preset in channels will be changed by this procedure. Preset them again.

vision antenna)

ision.

er.

d trademarks of

intellectual  
authorized by



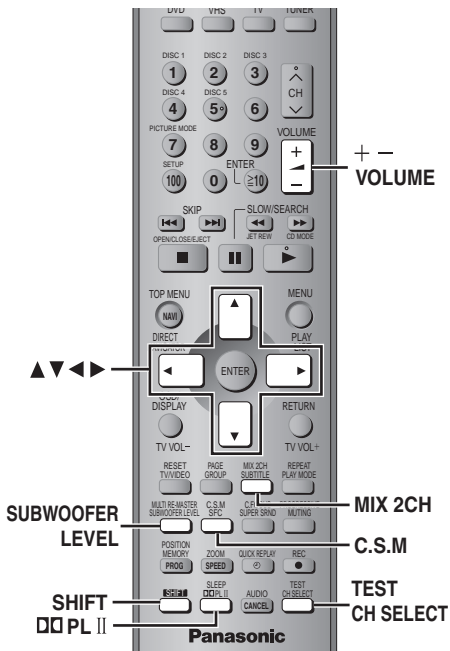

**“DVD/CD” as the source only**  
**Custom Sound Memory**  
 Stores up to 30 sound setting (one setting per disc).



**“DVD/CD” as the source only**  
**Down-mixing**  
 Down-mixes multi-channel signals to 2 channels.



**Subwoofer level**  
 Adjusts the amount of bass.

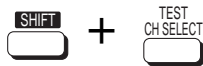

**Speaker level adjustments**

See below for details.



## Custom Sound Memory

DVD-A DVD-V VCD CD

### Available sound settings:

Subwoofer level, Center Focus, Sound Field Control, Super Surround

After making the sound field or sound quality settings

Press and hold  
**[SHIFT]+[C.S.M.]**



### Recall the settings

The unit recalls the settings when you play the disc again.

- The settings are replaced if you change them.
- When you store settings for the 31st disc, the settings for the earliest disc are cleared.
- Press [SHIFT]+[C.S.M.] while “CSM” is displayed and the settings return to those that were current before the settings were recalled.
- Press [SHIFT]+[C.S.M.] while “CSM” is out and you are playing a disc for which you stored settings and those settings are recalled.

## Down-mixing

You can output the down-mixed 2 channel signal when necessary (e.g. when you intend to record 5.1ch sound on other recording equipment).

Press  
**[SHIFT]+[MIX 2CH]**



### To cancel

Press [SHIFT]+[MIX 2CH] again.

### Note

- When “D.MIX” flashes on the display, the disc contains multiple-channel signals that cannot be down-mixed. **DVD-A**
- This does not work when Super Surround or Dolby Pro Logic II is turned on.

## Subwoofer level

Press **[SUBWOOFER LEVEL]**.



SUBW 1 → SUBW 2 → SUBW 3 → SUBW 4 (factory preset)



## Speaker level adjustments

This is one of the ways to get the appropriate surround effect. Adjust the speaker level to the same level as the front speakers.

- Dolby Digital and DTS: Turn off the other sound field systems.
- Dolby Pro Logic II and Dolby Pro Logic: Press [DOLBII].

**1**

While stopped

Press **[SHIFT]+[TEST]** to output a test signal.

Lch: Front left  
 Cch: Center  
 Rch: Front right  
 RSch: Right surround  
 LSch: Left surround

- There is no output from SW (subwoofer) channel.

**2**

Press **[VOLUME, +]** or **[−]** to set the volume level normally used for listening.

**3**

Press **[▲]** (increase) or **[▼]** (decrease) to adjust the speaker level for each speaker.

C, RS, LS: −6 dB to +6 dB

(L, R: Only the balance is adjustable.)

- To adjust the balance of the front speakers  
 While outputting the test signal, press **[◀▶]**.

### To stop the test signal

Press [SHIFT]+[TEST] again.

### To adjust speaker level during play

(Effective when playing multi-channel audio or Dolby Pro Logic II or Dolby Pro Logic is on.)

**1**

Press **[CH SELECT]** to select the speaker.

L→C→R→RS→LS→SW

↑

SW: Subwoofer

- You can only adjust SW if the disc includes a subwoofer channel.
- SW does not appear on the display and is not adjustable when Dolby Pro Logic II or Dolby Pro Logic is turned on.

**2**

Press **[▲]** (increase) or **[▼]** (decrease) to adjust the speaker level for each speaker.

C, RS, LS, SW: −6 dB to +6 dB

(L, R: Only the balance is adjustable.)

- To adjust the balance of the front speakers  
 During play, press **[◀▶]**.

### Super Surround

Press [SUPER SRND] then adjust the surround speaker level.

S: −6 dB to +6 dB



RADIO  
&  
OTHERS

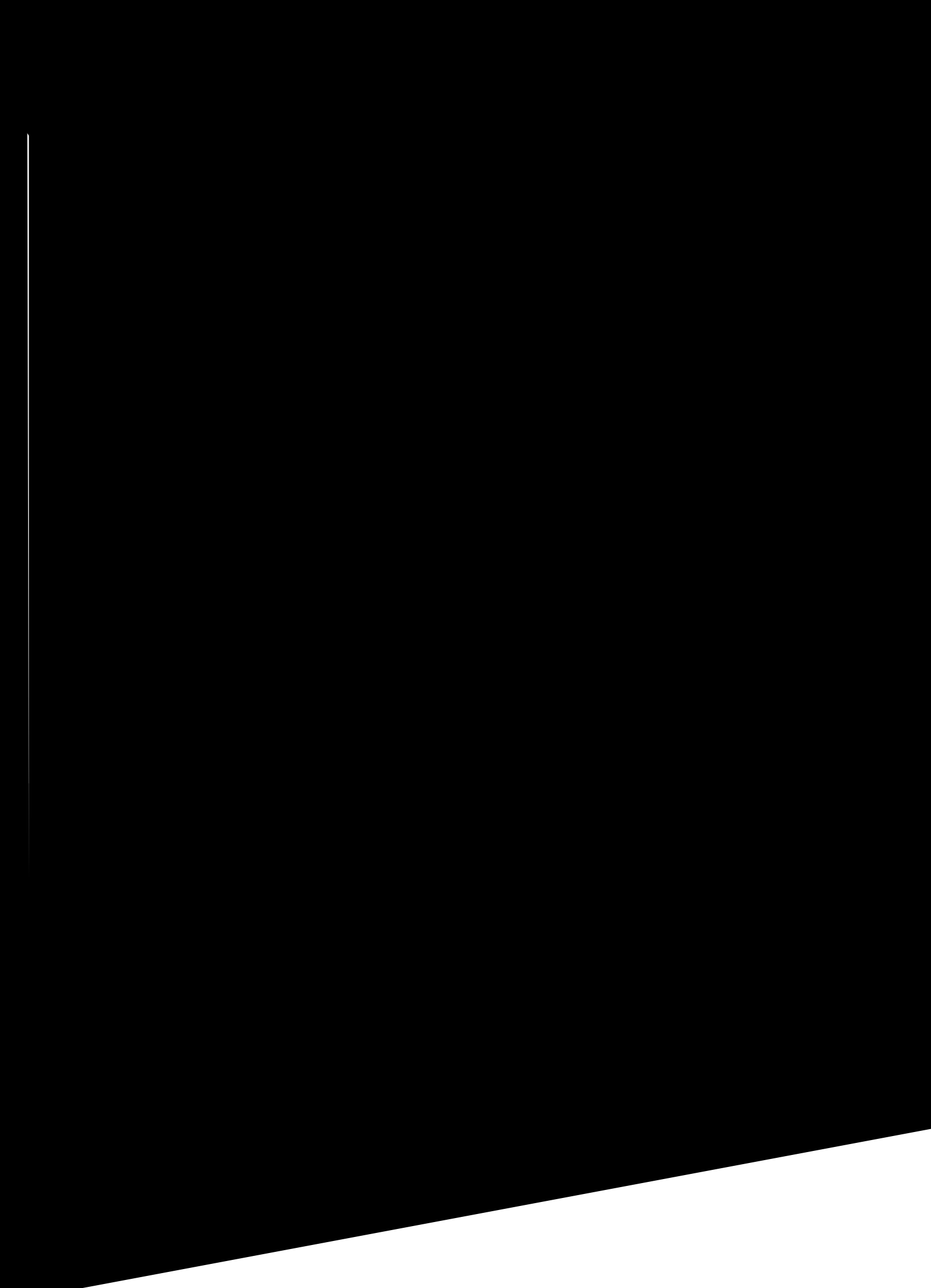



If the antenna connector doesn't match

**Other antenna connections to the unit**

Use one of the following connections to suit the antenna lead.

- If your television has both lead and coaxial VHF terminals, use the lead connection to minimize signal loss.

■ **A single twin lead**

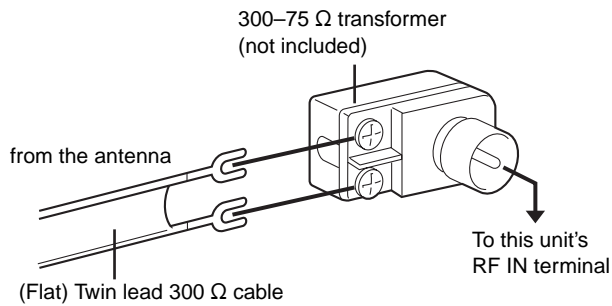

■ **A twin lead and a coaxial cable**

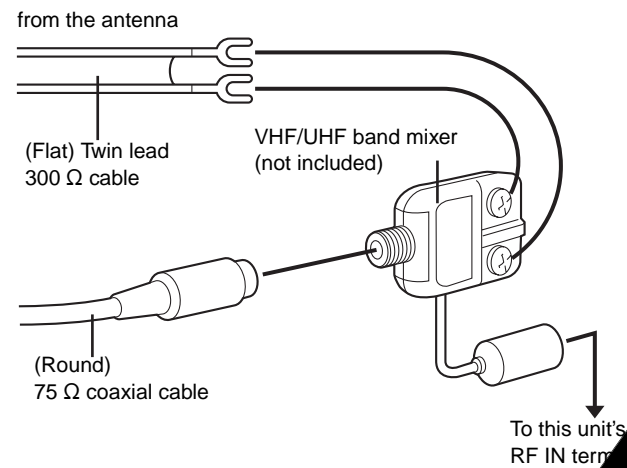

■ **Two twin leads**

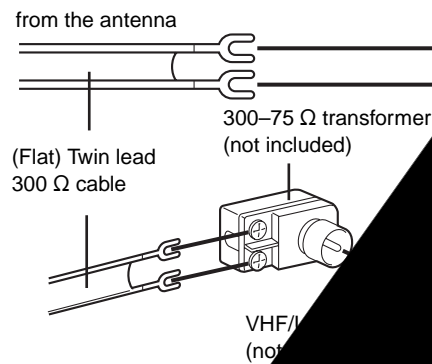

**Other antenna connections from the unit to the television**

Use one of the following connections to suit the antenna terminals on your television. Refer to the television's operating instructions.

■ **A twin lead and coaxial plug terminal**

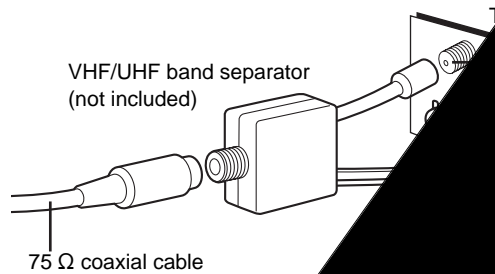

■ **A twin lead terminal**

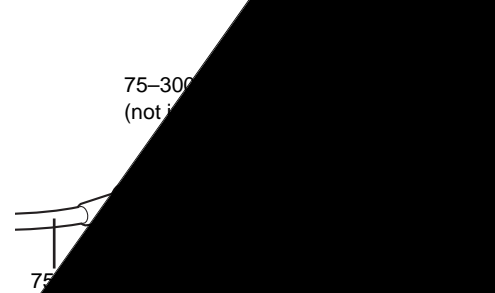

# Specifications

## ■ AMPLIFIER SECTION

<b>RMS output power, 10 % total harmonic distortion</b>	
1 kHz FL/FR	50 W per channel 6 Ω
1 kHz Center	150 W per channel 6 Ω
1 kHz SL/SR	50 W per channel 6 Ω
100 Hz Subwoofer	200 W per channel 4 Ω
<b>Total RMS Dolby Digital mode power</b> 550 W	
<b>FTC output power, 1 % total harmonic distortion</b>	
120 Hz–20 kHz FL/FR	28 W per channel 6 Ω
120 Hz–20 kHz Center	100 W per channel 6 Ω
120 Hz–20 kHz SL/SR	28 W per channel 6 Ω
45 Hz–120 Hz Subwoofer	128 W per channel 4 Ω
<b>Total FTC power in Dolby Digital mode (Band 1 % THD)</b> 340 W	
<b>Input sensitivity</b>	
AUX	250 mV
<b>Input impedance</b> 47 kΩ	

## ■ SPEAKER SECTION

### Front/Surround speakers SB-FS822

<b>Type</b>	2 way, 2 speaker system, Bass reflex
<b>Speaker unit(s)</b>	
Full range	6.5 cm (2 <sup>1</sup> / <sub>2</sub> " ), cone type, 6 Ω
Super Tweeter	Piezo type, 6 Ω
<b>Input power (IEC)</b>	60 W (Max)
<b>Output sound pressure</b>	79 dB/W (1.0 m)
<b>Cross over frequency</b>	10 kHz
<b>Frequency range</b>	85 Hz–25 kHz (–16 dB) 90 Hz–22 kHz (–10 dB)
<b>Dimensions (W×H×D)</b>	250×1061.5×250 mm (with stand) (9 <sup>27</sup> / <sub>32</sub> " × 41 <sup>25</sup> / <sub>32</sub> " × 9 <sup>27</sup> / <sub>32</sub> " ) (with stand)
<b>Mass</b>	4.1 kg (9.0 lb.) (with stand)

### Center speaker SB-PC820

<b>Type</b>	1 way, 2 speaker system, Bass reflex
<b>Speaker unit(s)</b>	
Full range	6.5 cm (2 <sup>1</sup> / <sub>2</sub> " ), cone type, 6 Ω
<b>Input power (IEC)</b>	160 W (Max)
<b>Output sound pressure</b>	83 dB/W (1.0 m)
<b>Frequency range</b>	97 Hz–25 kHz (–16 dB) 125 Hz–22 kHz (–10 dB)
<b>Dimensions (W×H×D)</b>	250×103×114 mm (9 <sup>27</sup> / <sub>32</sub> " × 4 <sup>1</sup> / <sub>16</sub> " × 4 <sup>15</sup> / <sub>32</sub> " )
<b>Mass</b>	1.31 kg (2.89 lb.)

### Active subwoofer SB-WA822

<b>Type</b>	1 way, 1 speaker system, Bass reflex
<b>Speaker unit(s)</b>	
Woofer	17 cm (6 <sup>3</sup> / <sub>4</sub> " ), cone type, 4 Ω
<b>Output sound pressure</b>	80 dB/W (1.0 m)
<b>Frequency range</b>	32 Hz–220 Hz (–16 dB) 36 Hz–190 Hz (–10 dB)
<b>Dimensions (W×H×D)</b>	209×360.5×463 mm (8 <sup>7</sup> / <sub>32</sub> " × 14 <sup>7</sup> / <sub>32</sub> " × 18 <sup>7</sup> / <sub>32</sub> " )
<b>Mass</b>	11.5 kg (25.4 lb.)

## ■ DISC SECTION

### Discs played [8 cm (3") or 12 cm (5")]

- DVD-RAM (DVD-VR formatted discs, JPEG formatted discs)
- DVD-Audio
- DVD-Video
- DVD-R (DVD-Video formatted discs)
- CD-Audio (CD-DA)
- Video CD
- SVCD (Conforming to IEC62107)
- CD-R/CD-RW (CD-DA, Video-CD, SVCD, MP3, WMA, JPEG formatted discs)
- MP3/WMA
  - Maximum number of tracks and groups recognizable: 999 tracks and 99 groups
  - Compatible compression rate:
    - MP3: between 32 kbps and 320 kbps
    - WMA: between 48 kbps and 320 kbps
- JPEG
  - Exif Ver 2.1 JPEG Baseline files
  - Maximum number of pictures and groups recognizable: 4000 pictures and 400 groups
  - Picture resolution: between 320×240 and 6144×4096 pixels (sub sampling is 4:2:2 or 4:2:0)
- HighMAT Level 2 (Audio and Image)

### Video

<b>Signal system</b>	NTSC
<b>Output level</b>	Composite video; 1 Vp-p (75 Ω) S-video; 1 Vp-p (Y), 0.286 Vp-p (C) (75 Ω) Component video; 1 Vp-p (Y) (75 Ω) 0.7 Vp-p (P <sub>B</sub> /C <sub>B</sub> , P <sub>R</sub> /C <sub>R</sub> ) (75 Ω)

### Audio

<b>Sampling frequency</b>	
CD	44.1 kHz
MP3	32 kHz, 44.1 kHz, 48 kHz
DVD-Linear	48 kHz, 96 kHz
DVD-Audio	192 kHz
<b>Decoding</b>	16/20/24 bit linear
<b>Pick up</b>	
Beam Source	Semiconductor Laser
<b>Wavelength</b>	
CD/VCD	785 nm
DVD	662 nm
<b>Number of channels</b>	5.1 ch (FL, FR, SL, SR, C, SW)
<b>Frequency response</b>	20 Hz–20 kHz (+1, –2 dB)

## ■ VHS SECTION

<b>Video recording system</b>	2 rotary heads, helical scanning system
<b>Video heads</b>	4 heads
<b>Audio heads</b>	2 heads
<b>Tape speed</b>	SP; 33.35 mm/s, EP; 11.12 mm/s
<b>Tape format</b>	VHS tape
<b>Recording/playback time</b>	SP; 120 min. with NV-T120 EP; 360 min. with NV-T120
<b>FF/REW time</b>	Approx. 54 s. with NV-T120 (FF/REW) Approx. 36 s. with NV-T120 (JET REW)

## VIDEO

<b>Television system</b>	EIA; Standard (525 lines, 60 fields), NTSC color signal
<b>Modulation system</b>	Luminance; FM azimuth recording Color signal; converted subcarrier phase shift recording
<b>Input level</b>	VIDEO IN; 1 Vp-p, 75 Ω
<b>Output level</b>	VIDEO OUT; 1 Vp-p, 75 Ω
<b>Antenna receive input</b>	VHF 2–13 CH, 75 Ω UHF 14–69 CH, 75 Ω CATV 5A and A-5–EEE CH, 75 Ω

## AUDIO

<b>Input level</b>	AUDIO IN (PHONO); –10 dBV, 47 kΩ
<b>Output level</b>	AUDIO OUT (PHONO); –8 dBV, 1 kΩ
<b>Audio track</b>	1 track (normal-mono only), 2 channels (Hi-Fi sound stereo)
<b>Video horizontal resolution</b>	Color; more than 200 lines
<b>Signal-to-Noise ratio</b>	Video; more than 40 dB/SP Audio; more than 60 dB/Hi-Fi
<b>Audio frequency response</b>	20 Hz–20 kHz/Hi-Fi
<b>Wow and flutter</b>	0.005 %

## ■ FM TUNER SECTION

<b>Frequency range</b>	87.9–107.9 MHz (200-kHz step) 87.5–108.0 MHz (100-kHz step)
<b>Sensitivity</b>	2.5 μV (IHF)
<b>S/N 26 dB</b>	2.2 μV
<b>Antenna terminals</b>	75 Ω (unbalanced)
<b>Preset station</b>	15

## ■ AM TUNER SECTION

<b>Frequency range</b>	520–1710 kHz (10-kHz step)
<b>AM Sensitivity S/N 20 dB at 1000 kHz</b>	560 μV/m
<b>Preset station</b>	15

## ■ GENERAL

<b>Power supply</b>	AC 120 V, 60 Hz
<b>Power consumption</b>	
Main unit	38 W
Subwoofer SB-WA822	250 W
<b>Dimensions (W×H×D)</b>	430×105×352 mm (16 <sup>15</sup> / <sub>16</sub> " × 4 <sup>1</sup> / <sub>8</sub> " × 13 <sup>7</sup> / <sub>8</sub> " )
<b>Mass</b>	5 kg (11 lb.)

### Power consumption in standby mode (when Demo function is off)

BRIGHT mode	Approx. 3.5 W (main unit) + 0.3 W (subwoofer)
DIM mode	Approx. 3.2 W (main unit) + 0.3 W (subwoofer)
OFF mode	Approx. 1.9 W (main unit) + 0.3 W (subwoofer)

### Note

- Specifications are subject to change without notice. Mass and dimensions are approximate.
- Total harmonic distortion is measured by the digital spectrum analyzer.



INFO

# Troubleshooting guide

Before requesting service, make the following checks. If you are in doubt about some of the check points, or if the remedies indicated in the chart do not solve the problem, refer to the "Customer Services Directory" on page 55.

Power		Page
No power.	•Insert the AC power supply cords and system cable securely.	16
The unit is automatically switched to the standby mode.	•The Sleep timer functioned.	48
No operation		
No response when any buttons pressed.	•This unit cannot play discs other than the ones listed in these operating instructions. •The unit may not be operating properly due to lightning, static electricity or some other external factor. Turn the unit off and then back to ON. Alternatively, turn the unit off, disconnect both AC power supply cords, and then reconnect them. •Condensation has formed: Wait 1 to 2 hours for it to evaporate.	6 — —
No response when remote control buttons pressed.	•Check that the batteries are installed correctly. •The batteries are depleted: Replace them with new ones. •Point the remote control at the remote control sensor and operate.	4 4 20
Cannot play DVDs.	•CD Mode is on. Press [SHIFT]+[CD MODE] to turn CD Mode off.	23
No picture or sound.	•Check the video and audio connection. •Check the power or input setting of the connected equipment. •Check that the DVD-RAM has something recorded on it.	13–16 — —
You have forgotten your ratings password. Reset all the settings to Factory Preset.	•While stopped and "DVD/CD" is the source, press [DVD] and then press and hold [■] (DVD) on the main unit and [≥10] on the remote control until "Initialized" disappears from the television. Turn the unit off and on again. All settings will return to the default values.	—
Cannot operate the DVD.	•Press [DVD] to switch the remote control mode to DVD.	—
Cannot operate the VHS.	•Press [VHS] to switch the remote control mode to VHS. •The unit is in timer recording standby ("Ⓞ" is on on the unit's display). •The remote control and main unit are using different codes. Change the code on the remote control.	— 36 42
Cannot operate the TV.	•Press [TV] to switch the remote control mode to TV. •Check the TV maker setting.	— 18
Television reception worsens after connecting the unit.	•This can occur because the signals are being divided between the unit and the television. You can solve this with a signal booster, available from audio-visual suppliers. Consult your dealer if reception does not improve.	—
Cannot eject cassette.	•The unit is recording or in timer recording standby mode. If you need to eject the tape, press [Ⓞ] first so "Ⓞ" goes out.	36
Specific operation impossible or incorrect		
It takes time before play starts. MP3	•Play may take time to begin when an MP3 track has still picture data. Even after the track starts, the correct play time will not be displayed, however this is normal.	—
Folders deeper than the eighth layer on a data CD are not displayed correctly. WMA MP3 JPEG	•Folders deeper than the eighth layer are displayed as the eighth layer.	—
Programmed items are not played. DVD-V	•Some items will not be played even if you have programmed them.	—
A menu screen appears during skip or search. VCD	•This is normal for Video CDs.	—
The on-screen menu shows "2" as a soundtrack option when [SHIFT]+[AUDIO] is pressed, but the audio does not change. DVD-A	•Even if a second soundtrack isn't recorded, two numbers will normally be shown.	—
Play restarts from the beginning of the track when soundtrack is changed. DVD-A	•This is normal on DVD-Audio.	—
Subtitle		
Subtitle position is wrong.	•Adjust the position. ("Subtitle Position" in Display Menu)	29
No subtitles.	•Display the subtitles.	22
The subtitles overlap closed captions recorded on discs.	•Clear the subtitles.	22
Marker		
Cannot add markers.	•You cannot add markers with DVD-RAM if the disc's play time doesn't appear on the unit's display.	—
A-B repeat		
Point B is automatically determined.	•The end of an item becomes point B when it is reached.	—
A-B repeat is automatically canceled.	•A-B repeat is canceled when you press [QUICK REPLAY].	—
Menu		
The Setup menu cannot be accessed.	•Select "DVD/CD" as the source. •Cancel all group, program and random play.	— 24, 25

## Picture incorrect

<b>Picture distorted.</b>	<ul style="list-style-type: none"> <li>● Ensure that the unit is connected directly to the television, and is not connected through an A/V selector or other equipment.</li> </ul>	<b>14</b>
<b>The television may display incorrectly or colors appear faded.</b>	<ul style="list-style-type: none"> <li>● The unit and television are using different video systems. Use a multi-system or NTSC television.</li> <li>● The system used on the disc doesn't match your television. PAL discs cannot be played. This unit converts DVD-Audio recorded in PAL to NTSC for play, however, play may not function properly.</li> </ul>	— —
<b>The picture on the television disappears or stripes appear on the screen.</b>	<ul style="list-style-type: none"> <li>● Mobile telephone chargers can cause some disturbance.</li> <li>● If you are using a TV indoor antenna, change to an outdoor antenna.</li> <li>● The television antenna wire is too close to the unit. Separate the antenna wire of the television from the unit.</li> </ul>	— — —

## Disc picture incorrect

<b>Picture size doesn't fit the screen.</b>	<ul style="list-style-type: none"> <li>● Change "TV Aspect" in "Video" tab.</li> <li>● Use the television to change the aspect. If your television does not have that function, change "4:3 Aspect" in Display Menu.</li> <li>● Change the Zoom setting.</li> </ul>	<b>30</b> <b>29</b> <b>22</b>
<b>Menus not displayed correctly.</b>	<ul style="list-style-type: none"> <li>● Restore the zoom ratio to <math>\times 1.00</math>.</li> <li>● Set "Subtitle Position" in Display Menu to "0".</li> <li>● Set "4:3 Aspect" in Display Menu to "Normal".</li> </ul>	<b>22</b> <b>29</b> <b>29</b>
<b>Auto zoom function does not work well.</b>	<ul style="list-style-type: none"> <li>● Turn off TV's zoom function.</li> <li>● Use the other preset aspect ratios or manual adjustment.</li> <li>● Zoom function may not work well, especially in dark scenes and may not work depending on the type of disc.</li> </ul>	— <b>22</b> —

## VHS picture incorrect

<b>The picture is noisy or is in black and white. Horizontal bars or lines run down the screen.</b>	<ul style="list-style-type: none"> <li>● Adjust the tracking.</li> <li>● Make sure the television's input setting is correct.</li> <li>● The video heads are dirty: clean them with a head-cleaning cassette.</li> <li>● The video heads are worn: consult your dealer.</li> <li>● The tape is old or damaged.</li> <li>● You cannot correctly play tapes recorded with other systems (e.g., PAL).</li> </ul>	<b>33</b> — <b>54</b> — — —
<b>Picture is distorted when stilled or during slow-motion.</b>	<ul style="list-style-type: none"> <li>● Some distortion is normal with tapes recorded using VP mode.</li> </ul>	—
<b>The blue back appears during play.</b>	<ul style="list-style-type: none"> <li>● You are playing a blank or poor quality part of the tape.</li> <li>● You can damage the unit if you play dirty or damaged tapes and this can cause the blue back to appear. Consult your dealer.</li> </ul>	— —
<b>The picture jiggles.</b>	<ul style="list-style-type: none"> <li>● Adjust the vertical hold.</li> </ul>	<b>33</b>

## Progressive video

<b>There is ghosting when progressive output is on.</b>	<ul style="list-style-type: none"> <li>● Change "Video Output Mode" in Picture Menu to "480i". This problem is caused by the editing method or material used on DVD-Video, but should be corrected if you use interlace output.</li> </ul>	<b>29</b>
<b>Pictures not in progressive output.</b>	<ul style="list-style-type: none"> <li>● If the unit is connected to the television through VIDEO OUT or S-VIDEO OUT output will be interlace.</li> <li>● Press [SHIFT]+[PROGRESSIVE]. Or select "480P" in "Video Output Mode" in Picture Menu.</li> </ul>	— <b>20, 29</b>
<b>Closed captions not displayed.</b>	<ul style="list-style-type: none"> <li>● When progressive output is on, closed captions will not be displayed.</li> </ul>	—

## Sound incorrect

<b>Sound distorted.</b>	<ul style="list-style-type: none"> <li>● Noise may occur when playing WMA files.</li> </ul>	—
<b>Effects do not work.</b>	<ul style="list-style-type: none"> <li>● Some audio effects do not work or have less effect with some discs.</li> <li>● Multi Re-master and Dolby Pro Logic II do not work if you have changed the play speed.</li> <li>● When connected with headphones, only Sound Field Control is effective.</li> </ul>	— — —
<b>Humming heard during play.</b>	<ul style="list-style-type: none"> <li>● An AC power supply cord or fluorescent light is near the subwoofer. Keep other appliances and cords away from the subwoofer.</li> </ul>	—
<b>There is noise when playing a video tape.</b>	<ul style="list-style-type: none"> <li>● Adjust the tracking.</li> <li>● The tape is old or damaged.</li> </ul>	<b>33</b> —

## Listening to the radio

<b>Noise is heard. "ST" flickers or doesn't light. Sound is distorted.</b>	<ul style="list-style-type: none"> <li>● Adjust the position of the FM or AM antenna.</li> <li>● Use an outdoor antenna.</li> </ul>	— <b>45</b>
<b>A beat sound is heard.</b>	<ul style="list-style-type: none"> <li>● Turn the television off or separate it from the unit.</li> </ul>	—
<b>A low hum is heard during AM broadcasts.</b>	<ul style="list-style-type: none"> <li>● Separate the antenna from other cables.</li> </ul>	—

## Recording

<b>"[Erase Prevention Tab Icon]" flashes when I try to start recording. Cannot record.</b>	<ul style="list-style-type: none"> <li>● If the erasure prevention tab has been removed, cover the hole with adhesive tape.</li> </ul>	<b>5</b>
<b>Timer recording doesn't record a program correctly.</b>	<ul style="list-style-type: none"> <li>● Check the clock and calendar.</li> <li>● Set the channel and start and end times correctly.</li> <li>● Be sure to press [⊙] after programming to put the unit in timer recording standby.</li> <li>● Program times may be overlapped.</li> </ul>	— — <b>36</b> —
<b>Cannot record from other equipment.</b>	<ul style="list-style-type: none"> <li>● Press [^ CH] or [v CH] to select "AU".</li> <li>● Check the connections to the other equipment.</li> </ul>	<b>35</b> <b>35</b>
<b>Black bands appear in the recording.</b>	<ul style="list-style-type: none"> <li>● Move the other equipment away from the television as it may be picking up interference.</li> </ul>	—
<b>The copy of a videotape or DVD is very poor.</b>	<ul style="list-style-type: none"> <li>● This unit complies with industry standards regarding the recording and duplication of copy-protected material. This includes commercial videotapes and DVDs. Consequently, copying not only infringes copyright laws but also presents serious technical difficulties. Even in cases where a copy can be made, the quality will be very poor.</li> </ul>	—



INFO



# Limited Warranty

**Panasonic Consumer Electronics Company,  
Division of Matsushita Electric Corporation of America**  
One Panasonic Way Secaucus, New Jersey 07094

**Panasonic Sales Company, Division of Matsushita Electric  
of Puerto Rico, Inc.,**  
Ave. 65 de Infantería, Km. 9.5  
San Gabriel Industrial Park, Carolina, Puerto Rico 00985

## **Panasonic Audio Products Limited Warranty**

### **Limited Warranty Coverage**

If your product does not work properly because of a defect in materials or workmanship, Panasonic Consumer Electronics Company or Panasonic Sales Company (collectively referred to as "the warrantor") will, for the length of the period indicated on the chart below, which starts with the date of original purchase ("warranty period"), at its option either (a) repair your product with new parts and labor, or (b) replace your product with a new one of similar kind.



**INFO**

## Common

Batteries.....	4
Center Focus .....	46
Cleaning	
Discs.....	6
Main unit.....	54
Video heads.....	54
Connection	
Antennas.....	16
Cable TV.....	49
LINE IN/OUT.....	35, 49
Optional antenna connection.....	50
Speakers.....	10, 13
Subwoofer.....	13
Television.....	14
Custom Sound Memory.....	47
Demo.....	16
Dolby Pro Logic.....	46
Dolby Pro Logic II.....	46
Down-mixing.....	47
Headphones.....	48
Muting.....	48
Remote control mode.....	7
Sleep timer.....	48
Sound field control.....	46
Source selector.....	7, 9
Speaker level adjustments.....	47
Subwoofer level.....	47
Super Surround.....	46

## DVD

A-B repeat.....	29
All group play.....	24
CD mode.....	23
COMPONENT VIDEO.....	15
Data discs.....	26
Dialogue Enhancer.....	29
Direct Navigator.....	27
HDCCD.....	6
HighMAT.....	6, 27, 31
JPEG.....	27
Marker.....	28, 29
MP3.....	27
Multi Re-master.....	23
Navigation menus.....	26, 27
On-Screen Menu.....	28, 29
Page skip.....	23
Picture mode.....	29
Play list.....	27
Play speed.....	29
Position memory.....	22
Program play.....	24
Progressive.....	15, 20
Quick replay.....	23
QUICK SETUP.....	19, 31
Random play.....	24, 25
Ratings.....	30
Region number.....	Cover
Repeat play.....	25
Rotate picture.....	28

Sampling frequency.....	23
Settings.....	30, 31
Speaker delay time.....	31
Subtitle.....	22
S-VIDEO.....	15
WMA.....	27
Zoom.....	22

## VHS

Auto bilingual choice function.....	43
Categories.....	39
Clock setting	
Auto clock setting.....	17, 40
Manual clock setting.....	40
Jet Navigator.....	38, 42
Jet rewind.....	32
Jet search.....	32, 42
MTS.....	42
On-screen display.....	43
Picture mode.....	33
Recording	
LINE IN.....	35
Timer recording.....	36
TV program.....	34
REMOTE CONTROL.....	42
Repeat play.....	33
SAP.....	43
Settings.....	40-43
SQPB.....	5
Tape counter.....	43
Tape length.....	42
Tape speed	
Auto SP/EP change.....	37
EP.....	34
LP.....	34
SP.....	34
VP.....	34
Tape's tab.....	5
Tracking.....	33
TV channel tuning	
Antenna system.....	41
Auto tuning.....	41
Manual tuning.....	41
Plug-in Auto Tuning.....	17
Vertical locking adjustment.....	33
VHS Index Search System (VISS).....	39

## TUNER

AM	
Antenna connection.....	16
FM	
Antenna connection.....	16, 45
Antenna plug.....	45
Frequency step.....	44

## TV

Connection.....	14, 15
TV maker setting.....	18
TV operation.....	18