

Panasonic

Color CCTV Cameras Operating Instructions

Model No. **WV-CL920**
WV-CL924

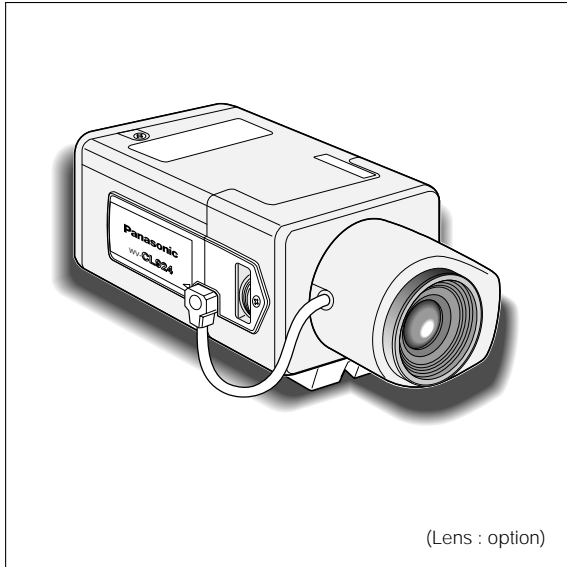

Before attempting to connect or operate this product,
please read these instructions carefully and save this manual for future use.



SA 1965

The lightning flash with arrowhead symbol, within an equilateral triangle, is intended to alert the user to the presence of uninsulated "dangerous voltage" within the product's enclosure that may be of sufficient magnitude to constitute a risk of electric shock to persons.



SA 1966

The exclamation point within an equilateral triangle is intended to alert the user to the presence of important operating and maintenance (servicing) instructions in the literature accompanying the appliance.

NOTE: This equipment has been tested and found to comply with the limits for a Class A digital device, pursuant to Part 15 of the FCC Rules. These limits are designed to provide reasonable protection against harmful interference when the equipment is operated in a commercial environment. This equipment generates, uses, and can radiate radio frequency energy and, if not installed and used in accordance with the instruction manual, may cause harmful interference to radio communications.

Operation of this equipment in a residential area is likely to cause harmful interference in which case the user will be required to correct the interference at his own expense.

FCC Caution: To assure continued compliance, (example - use only shielded interface cables when connecting to computer or peripheral devices). Any changes or modifications not expressly approved by the party responsible for compliance could void the user's authority to operate this equipment.

The serial number of this product may be found on the top of the unit.

You should note the serial number of this unit in the space provided and retain this book as a permanent record of your purchase to aid identification in the event of theft.

Model No. _____

Serial No. _____

WARNING:

To reduce the risk of fire or electric shock, do not expose this appliance to rain or moisture.

CONTENTS

PREFACE	4
FEATURES	4
PRECAUTIONS	5
MAJOR OPERATING CONTROLS AND THEIR FUNCTIONS	6
CONNECTIONS	9
FOCUS OR FLANGE-BACK ADJUSTMENT	13
INSTALLATION OF CAMERA	14
SETUP	16
1. CAMERA SETUP MENU	16
2. SETUP OPERATION	19
SETTING PROCEDURES	21
PREVENTION OF BLOOMING AND SMEAR	39
SPECIFICATIONS	40
STANDARD ACCESSORIES	42
OPTIONAL ACCESSORIES	43

PREFACE

Panasonic's WV-CL920 (WV-CL924) series digital color camera introduces a new level of high picture quality and high resolution through the use of a 1/2-inch frame interline transfer CCD image sensor having 768 hori-

zontal pixels (picture elements), and digital signal processing LSI's. This model offers cutting-edge technology for advanced video surveillance.

FEATURES

1. The following functions are built in.
 - (1) Auto Light Control (ALC)/Electronic Light Control (ELC)
 - (2) Back Light Compensation (Auto: Factory preset, Manual: Manual photometric measuring area set)
 - (3) Various External Sync Functions, including Gen-Lock
 - (4) Auto/Manual White Balance Function
 - (5) Electronic Shutter Function
2. Signal-to-noise ratio of 50 dB
3. Minimum illumination of 0.3 lux (0.03 footcandle) with F1.4 lenses (Color mode)
4. Minimum illumination of 0.02 lux (0.002 footcandle) with F1.4 lenses (Black and White mode)
5. 570 lines of horizontal resolution (Black and White mode)
480 lines of horizontal resolution (Color mode)
6. High quality picture:
 - (a) 2H type vertical enhancer for greater picture sharpness
 - (b) Chroma averaging circuit for better color signal to noise ratio
 - (c) Minimum of aliasing on fine objects
 - (d) Expanded dynamic range by use of knee circuit
 - (e) Highlight aperture correction for greater picture detail of bright objects
7. Ability to shoot indoor scenes with fixed iris lens by use of Electronic Light Control (ELC) function.
8. Selectable electronic sensitivity enhancing modes including: AUTO, MANUAL and OFF
9. Built in Digital Motion Detector
10. Auto Black/White mode enables the camera to switch between C/L and B/W in response to input lights.

PRECAUTIONS

1. Do not attempt to disassemble the camera.

To prevent electric shock, do not remove screws or covers.

There are no user serviceable parts inside. Ask a qualified service person for servicing.

2. Handle the camera with care.

Do not abuse the camera. Avoid striking, shaking, etc. The camera could be damaged by improper handling or storage.

3. Do not expose the camera to rain or moisture, or try to operate it in wet areas.

Turn the power off immediately and ask a qualified service person for servicing. Moisture can damage the camera and also create the danger of electric shock.

4. Do not use strong or abrasive detergents when cleaning the camera body.

Use a dry cloth to clean the camera when dirty.

In case the dirt is hard to remove, use a mild detergent and wipe gently.

5. Clean the CCD faceplate with care.

Do not clean the CCD with strong or abrasive detergents. Use lens tissue or a cotton tipped applicator and ethanol.

6. Never face the camera towards the sun.

Do not aim the camera at bright objects. Whether the camera is in use or not, never aim it at the sun or other extremely bright objects. Otherwise, blooming or smear may be caused.

7. Do not operate the camera beyond the specified temperature, humidity or power source ratings.

Use the camera under conditions where temperature is between -10°C - $+50^{\circ}\text{C}$ (14°F - 122°F), and humidity is below 90 %. The input power source is 120 V AC 60 Hz for WV-CL920 and 12 V DC/24 V AC for WV-CL924.

Caution:

To prevent fire or electric shock hazard, use a UL listed cable (VW-1, style 1007) for the 12 V DC or 24 V AC Input Terminal.

MAJOR OPERATING CONTROLS AND THEIR FUNCTIONS

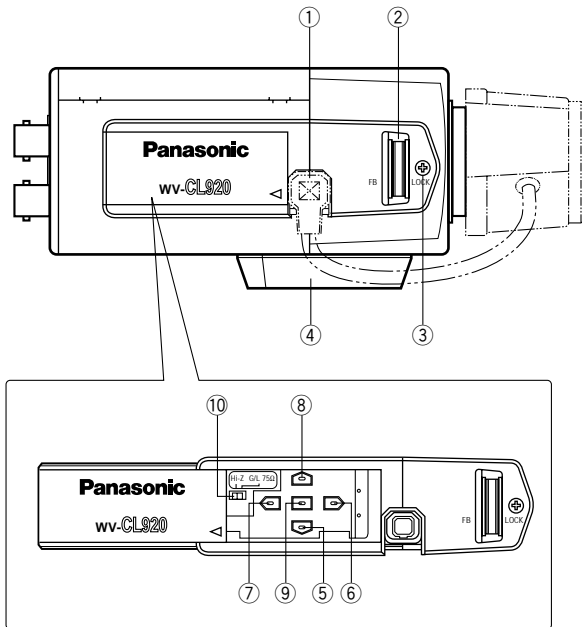

<WV-CL920>

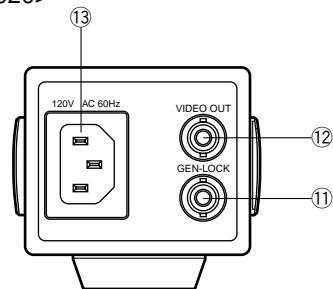

<WV-CL924>

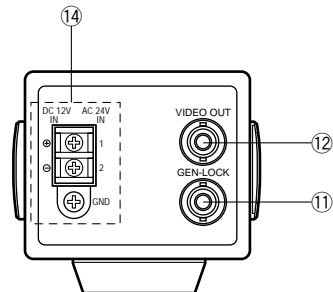

Slide the panel to the left until it locks.

- ① **Auto Iris Lens Connector**
This connector is used to connect the auto iris lens with a 4-pin male connector supplied as a standard accessory (Part No. YFE4191J100).
- ② **Flange-back Adjusting Ring (FB)**
This ring is used to adjust the back focal length or picture focus. Rotate this ring upward or downward for a CS-mount lens. In case of using a C-mount lens, adjust it with the C-mount adapter.
- ③ **Focus Fixing Screw (LOCK)**
- ④ **Camera Mounting Screw Hole**
This hole is used to mount the camera onto a mounting bracket.
- ⑤ **Down Button (⏮)**
This button is used to move the cursor downward. It is also used to select items in the CAM SET UP menu.
- ⑥ **Right Button (⏭)**
This button is used to move the cursor to the right. It is also used to select the mode and can be used to adjust some levels.
- ⑦ **Left Button (⏪)**
This button is used to move the cursor to the left. It is also used to select the mode and can be used to adjust some levels.
- ⑧ **Up Button (⏩)**
This button is used to move the cursor upward. It is also used to select items in the CAM SET UP menu.
- ⑨ **Set Button (⏹)**
This button is used to activate an item selected in the CAM SET UP menu.
- ⑩ **Gen-lock Termination Switch (Hi-Z, G/L 75Ω)**
Set this switch to Hi-Z when a gen-lock video input signal is looped through. In all other cases, set this switch to 75 Ω.
- ⑪ **Gen-lock Input Connector (GEN-LOCK)**
This connector is used to connect an external system for synchronization.
- ⑫ **Video Output Connector (VIDEO OUT)**
This connector is used to connect with the VIDEO IN connector of the monitor.

⑬ **Power Cord Socket**

This socket is used to connect the power cord (supplied as a standard accessory).

⑭ **AC/DC Compatible Input Terminal
(DC 12V IN/AC 24V IN)**

This terminal is for connecting the 12 V DC or 24 V AC power supply cord.

Cautions:

1. Connect to 12 V DC (10.5 V-16 V) or 24 V AC (19.5 V-28 V) class 2 power supply only. Make sure to connect the grounding lead to the GND terminal when the power is supplied from a 24 V AC power source.
2. To prevent fire or electric shock hazard, use a UL listed cable (VW-1, style 1007) for the Input Terminal.

CONNECTIONS

A. WV-CL920 (120 V AC 60Hz)

1. Plug the AC power cord (supplied as standard accessory) into the AC Inlet Socket.
2. Connect the AC power cord to a 120 V AC 60 Hz outlet.

Notes:

- Connect the power cord firmly.
- The power cord should be long enough for panning and tilting.
If the cable is too short, the power cord plug may be pulled off the camera when the camera pans or tilts.

B. WV-CL924 (12 V DC/24 V AC)

The WV-CL924 has an AC/DC compatible input terminal. The 12 V DC or 24 V AC power supply cord can be connected to this terminal. The camera detects the power source automatically.

1. 12 V DC Power Supply

Connect the power cord to the AC/DC compatible input terminal on the rear panel of the camera.

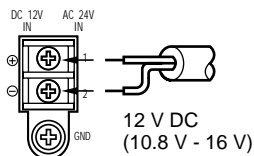

Resistance of copper wire [at 20°C (68°F)]

Copper wire size (AWG)	#24 (0.22 mm ²)	#22 (0.33 mm ²)	#20 (0.52 mm ²)	#18 (0.83 mm ²)
Resistance Ω /m	0.078	0.050	0.030	0.018
Resistance Ω /ft	0.026	0.017	0.010	0.006

- Calculation of maximum cable length between camera and power supply.

$$10.8 \text{ V DC} \leq V_A - (R \times 0.42 \times L) \leq 16 \text{ V DC}$$

L : Cable length (m)

R : Resistance of copper wire (Ω /m)

V_A : DC output voltage of power supply unit

$$L_{\text{standard}} = \frac{V_A - 12}{0.42 \times R} \quad (\text{m})$$

$$L_{\text{minimum}} = \frac{V_A - 16}{0.42 \times R} \quad (\text{m})$$

$$L_{\text{maximum}} = \frac{V_A - 10.5}{0.42 \times R} \quad (\text{m})$$

2. 24 V AC Power Supply

Connect the power cable to the AC/DC compatible input terminal on the rear panel of the camera.

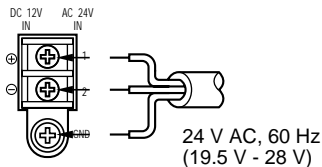

Recommended wire gauge sizes for 24 V AC line.

Copper wire size (AWG)		#24 (0.22 mm ²)	#22 (0.33 mm ²)	#20 (0.52 mm ²)	#18 (0.83 mm ²)
Length of Cable (Approx.)	(m)	95	150	255	425
	(ft)	314	495	842	1 403

Caution:

To prevent fire or electric shock hazard, use a UL listed cable (VW-1, style 1007).

Video Cable

1. It is recommended to use a monitor whose resolution is at least equal to that of the camera.
2. The maximum extensible coaxial cable length between the camera and the monitor is shown below.

Type of coaxial cable		RG-59/U (3C-2V)	RG-6/U (5C-2V)	RG-11/U (7C-2V)	RG-15/U (10C-2V)
Recommended maximum cable length	(m)	250	500	600	800
	(ft)	825	1 650	1 980	2 640

Installation of Auto Iris Lens Connector

Install the lens connector (YFE4191J100) when using a video drive ALC lens.

The installation should be made by qualified service personnel or system installers.

- (1) Cut the iris control cable at the edge of the lens connector to remove the existing lens connector and then remove the outer cable cover as shown in the diagram below.

The pin assignment of the lens connector is as follows:

Pin 1: Power source; +9 V DC, 50 mA Max.

Pin 2: Not used

Pin 3: Video signal; 1.3 V [p-p]/40 k Ω

Pin 4: Shield, ground

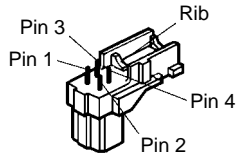

- (2) Solder the lens cable to the pins of the supplied connector.

Mounting the Lens

Caution:

Before you mount the lens, loosen the fixing screw on the side of the camera, and rotate this ring upward until it stops. If the ring is not at the end, the inner glass or CCD image sensor may be damaged.

1. Mount the lens by turning it clockwise on the lens mount of the camera.
2. Connect the lens cable to the auto iris lens connector on the side of the camera.

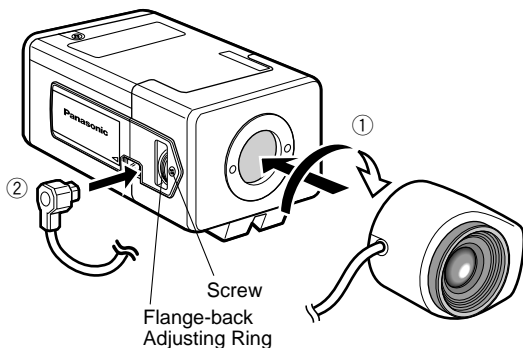

Caution for Mounting the Lens

The lens mount should be a CS-mount (1"-32UN). In case of a C-mount, it should be a C-mount adapter and the lens weight should be less than 450 g (0.99 lbs). If the lens is heavier, both the lens and camera should be secured by using the supporter.

The protrusion at the rear of the lens should be as shown below:

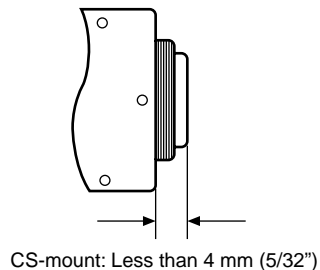

FOCUS OR FLANGE-BACK ADJUSTMENT

The following adjustment should be made by qualified service personnel or system installers.

1. Loosen the screw on the side of the camera.

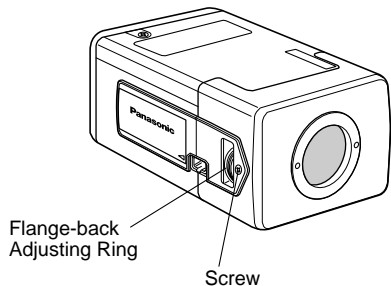

2. Turn the flange-back adjusting ring to the desired position.

Note: Adjusting a focus in the visible rays may be soft-focused with the near-infrared light.

3. Tighten the screws on the side of the camera.

Caution: Tightening the screw by force will cause damage to the screw or deviation of focus.

INSTALLATION OF CAMERA

- **Mounting from the top**

Remove the mount adapter from the bottom of the camera by removing the two fixing screws. Attach the mount adapter to the top as shown in the diagram, then mount the camera on the mounting bracket.

Make sure that the two original fixing screws are used when mounting the mount adapter as longer length screws may damage inner components.

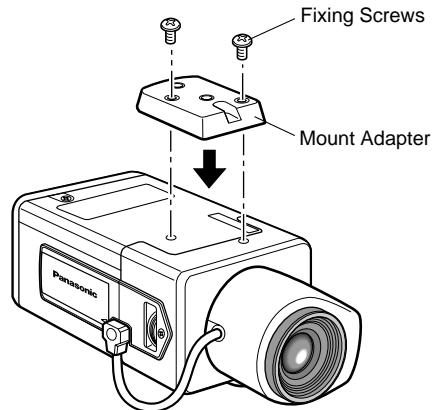

SETUP

1. CAMERA SETUP MENU

This camera utilizes a user setup menu that is displayed on-screen. The setup menu contains various items that form a tree type structure.

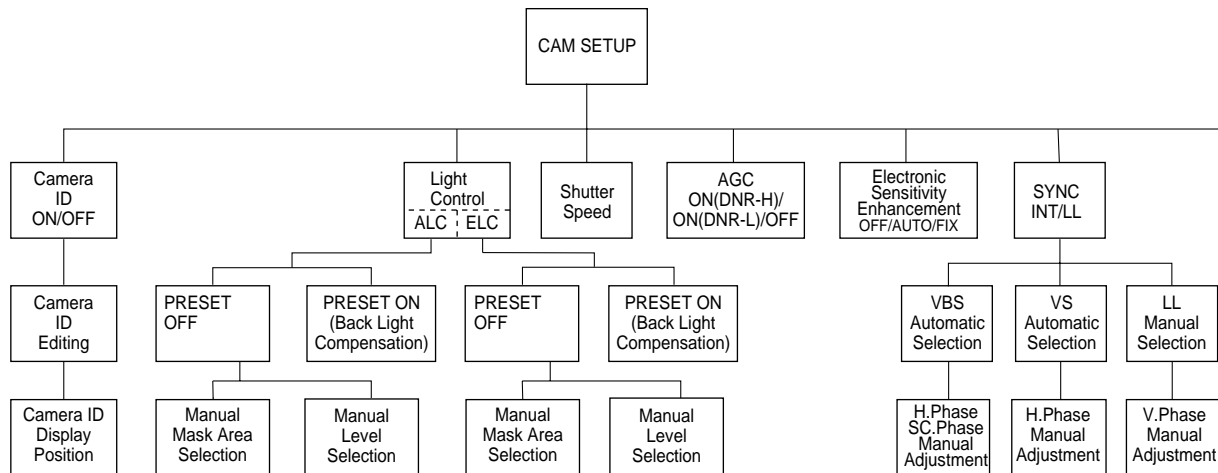

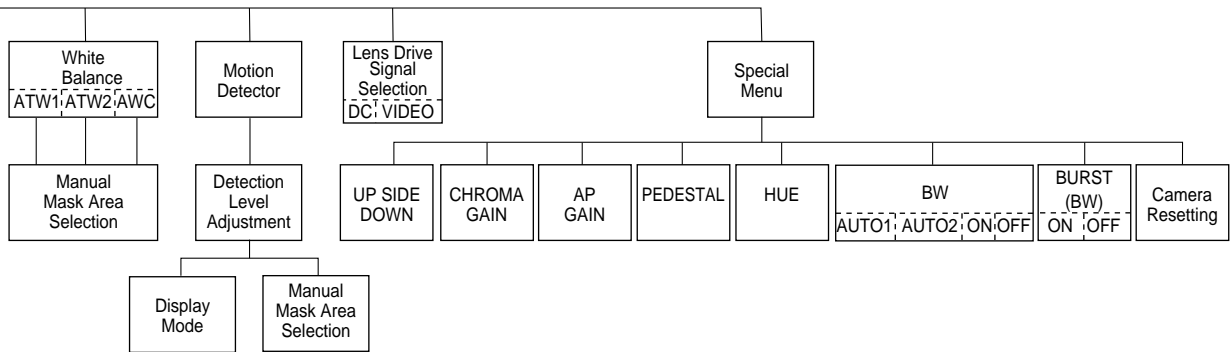

• Opening the Setup Menu

Press and hold down  for 2 seconds or more.

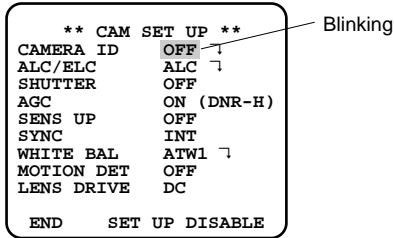

Note: If no button is pressed for 6 minutes while the CAM SET UP menu or any other menu is opened, the menu is automatically closed and the mode returns to the normal camera picture.

The CAM SET UP menu appears on the monitor as shown above.

Check the current settings on the menu.

Refer to the sections below for a detailed description of menu items. If you decide not to make any changes after checking the current settings, move the cursor to END at the start of the bottom line, and press  to close the CAM SET UP menu and return to normal camera picture mode.

2. SETUP OPERATION

This camera utilizes a user setup menu (CAM SET UP) that is displayed on the monitor.

To set items on the CAM SET UP menu, use the following buttons on the side panel.

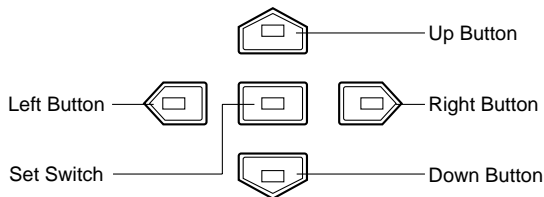

Up Button (🏠): Moves the cursor upwards. Use this button to select an item or adjust the parameters.

Down Button (⏴): Moves the cursor downwards. Use this button to select an item or adjust the parameters.

Right Button (➡): Moves the cursor to the right. Use this button to select or adjust the parameters of the selected item. The parameter changes each time this button is pressed.

Left Button (⏴): Moves the cursor to the left. Use this button to select or adjust the parameters of the selected item. The parameter changes each time this button is pressed.

Set Button (📁): Executes selection and displays a submenu for an item with ↓ mark. END: Close Setup menu. RET: Return to the previous menu or page.

To return to the CAM SET UP menu move the cursor to RET and press 📁.

• All Reset Operation





All Reset allows you to reset all setup menu items to the factory settings if you are unsure about the correct settings. Proceed as follows:

- (1) Make sure that the CAM SET UP menu is not displayed (a camera picture is displayed).
- (2) While pressing both ⏴ and ➡, press 📁 for a few seconds. The message ALL RESET momentarily appears on the monitor. This resets all adjustments and parameters to the factory default settings.

• Editing the CAM SET UP Menu

Important Notice:

When SET UP DISABLE appears in the bottom line of the CAM SET UP menu, you cannot change the currently active settings. This is to prevent accidental changing of the settings.

To edit the CAM SET UP menu (change settings), press  and  or  and  to move the cursor to SET UP DISABLE in the bottom line.

Press . SET UP DISABLE changes to SET UP ENABLE. Move the cursor to END, then to the item(s) you want to change.

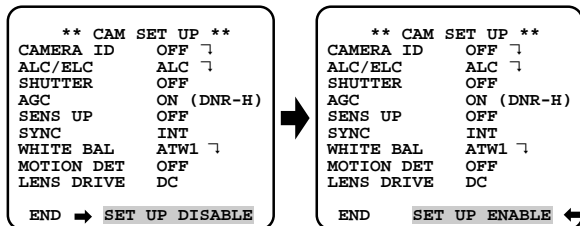

Important Notice:

When the cursor is moved to END and the CAM SET UP menu closed after changing the parameters, the new values are saved in the EEPROM (Electric Erasable and Programmable Read Only Memory). These values remain valid until new values are saved, even if the power of the camera is off.

SETTING PROCEDURES

1. Camera Identification (CAMERA ID) Setting

You can use the camera identification (CAMERA ID) to assign a name to the camera. The camera ID consists of up to 16 alphanumeric characters. The camera ID display can be switched on or off on the monitor screen.

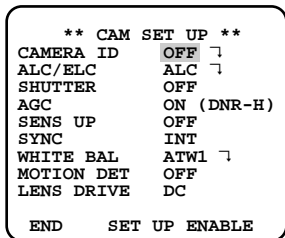

To edit the CAMERA ID

1. Move the cursor to the CAMERA ID parameter.
2. Press . The CAMERA ID menu appears. The cursor on the letter "0" is highlighted.

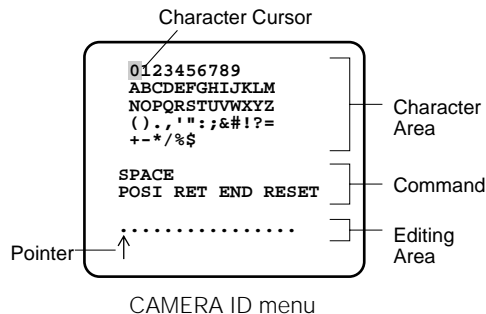

3. Move the cursor to the character you want to edit by pressing / / / .
4. After selecting the character, press . The selected character appears in the editing area. (The pointer in the editing area moves to the right automatically at this moment.)
5. Repeat the steps above until all characters are edited.

To enter a blank space in the CAMERA ID

Move the cursor to SPACE and press .

To replace a specific character in the CAMERA ID

1. Move the cursor to the editing area by pressing .

2. Move the pointer to the character to be replaced by pressing or . Then move the cursor to the character area and select a new character.
3. Press to determine the CAMERA ID.

To erase all characters in the editing area

Move the cursor to RESET and press . All characters in the editing area disappear.

To determine the display position of the CAMERA ID

1. Move the cursor to POSI, and press . The display shown below appears and the CAMERA ID is highlighted.

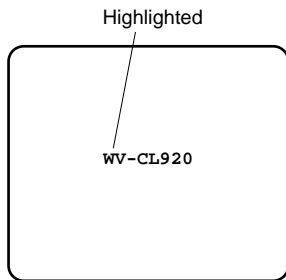

2. Move the CAMERA ID to the desired position by pressing / / / .

3. Press to fix the position of the CAMERA ID. The mode returns to the previous CAMERA ID menu.

Notes:

- The CAMERA ID stops at the edges of the monitor screen.
- The CAMERA ID moves faster if any of / / / is kept pressed for a second or more.

2. Light Control Setting (ALC/ELC)

You can select the mode for adjusting the lens iris.

The modes are as follows:

ALC: Select this mode when an auto iris lens (ALC lens) is used with this camera.

ELC: Select this mode when a fixed iris lens or manual iris lens is used with this camera.

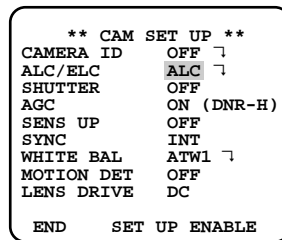

1. Move the cursor to the ALC/ELC parameter.
2. Select ALC or ELC.

Cautions:

1. Under bright lighting conditions such as outdoors, use an ALC type lens because the ELC control range is not wide enough under these conditions.
2. Use an ALC type lens if the following phenomena occur:
 - Strong smear and/or blooming on highlight objects such as spotlight or sunlight from windows.
 - Noticeable flicker in the picture and/or color rendition variations.
3. If ELC is selected, SHUTTER is not available.

Back Light Compensation (BACK LIGHT COMP)

Back light compensation is available for both the ALC and ELC modes. It eliminates strong background lighting which makes the camera picture dark, such as a spotlight. You can select one of two modes (PRESET ON or PRESET OFF) of back light compensation.

2-1. ALC Mode with PRESET ON

In normal use, the important object in a scene is placed in the center of the monitor's screen. In the factory setup mode, more photometric weight is given to the center of the screen (where the important object is located) than to the edge of the picture (where a bright backlight would most likely be located). In this mode, even though the backlight may vary, the object at the center of the screen can be still be clearly seen.

Note: If ELC is selected, set LEVEL according to this procedure.

```

** CAM SET UP **
CAMERA ID   OFF  ↵
ALC/ELC     ALC  ↵
SHUTTER     OFF
AGC         ON (DNR-H)
SENS UP     OFF
SYNC       INT
WHITE BAL   ATW1 ↵
MOTION DET  OFF
LENS DRIVE  DC

END        SET UP ENABLE

```

1. Select ALC and press . The ALC CONT menu appears.

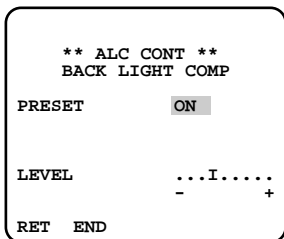
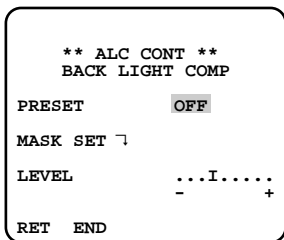

2. Move the cursor to the PRESET parameter and select ON.
The backlight compensation is automatically set.
3. If you want to change the video output level (picture contrast), move the "I" cursor for LEVEL and adjust the level.
4. Move the cursor to RET and press  to return to the CAM SET UP menu.

2-2. ALC Mode with PRESET OFF

These modes are effective when the main object in the scene is not located in the center of the screen and a source of bright light is located near the center of the screen. In these modes, the picture is divided into 48 areas that mask the light to keep the clarity of the picture.

Note: If ELC is selected, set MASK SET and LEVEL according to this procedure.

1. Move the cursor to the PRESET parameter and select OFF.
The item MASK SET appears on the menu.

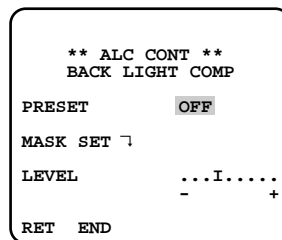

2. Move the cursor to MASK SET and press  .
The 48 mask areas appear on the monitor screen.
The cursor is blinking in the top left corner of the screen.

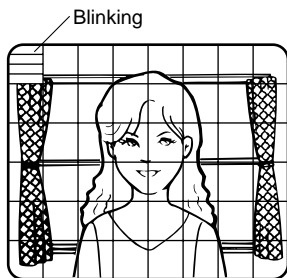

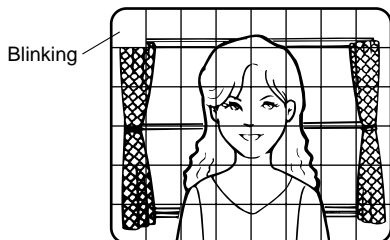

3. Move the cursor to the area where backlight is bright, and press  to mask that area. The mask turns white. (When the cursor is moved on an area that has already been masked, the mask and cursor start blinking.)

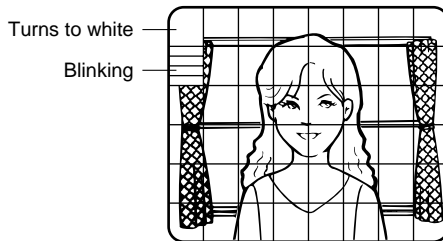

4. Repeat step 3 to mask the desired area. To cancel masking, move the cursor to that area and press  .



5. After masking is completed, press  for 2 seconds or more. The ALC CONT menu appears.
6. If you want to change the video output level (picture contrast), move the "I" cursor LEVEL and adjust the level.
7. Move the cursor to RET and press  to return to the CAM SET UP menu. (To return to the camera picture, move the cursor to END and press ).

Caution: When an auto iris lens requiring a DC control signal is used, the lens iris is fully opened in ELC mode.

3. Shutter Speed Setting (SHUTTER)

Note: When ELC is selected for ALC/ELC on the CAM SET UP menu, this item is not available.

You can select an electronic shutter speed of 1/60 (OFF), 1/100, 1/250, 1/500, 1/1 000, 1/2 000, 1/4 000, or 1/10 000 seconds.

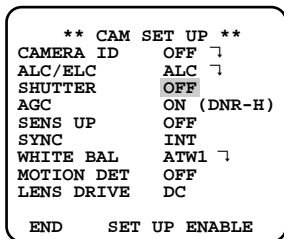

Move the cursor to the SHUTTER parameter and select the electronic shutter speed.

The preset values for SHUTTER (electronic shutter speed) change by pressing  or  as follows:

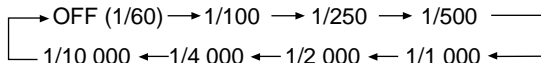

4. Gain Control Setting (AGC ON/OFF)

You can set the gain (brightness level portion of an image) to automatic level adjustment ON (DNR-H), ON (DNR-L) or fixed level (OFF).

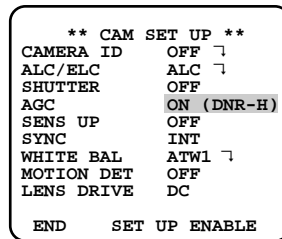

Move the cursor to the AGC parameter and select automatic level adjustment ON (DNR-H), ON (DNR-L) or fixed level (OFF).

Notes:

- If ON (DNR-H) is selected for the AGC parameter, the noise reduction function is automatically activated under low light conditions to reduce noise. In pictures containing a moving object, this may result in an afterimage.
- DNR-L is recommended for pictures containing a moving object that results in an afterimage. However, the noise slightly increases.
- DNR-H and DNR-L do not appear for the AGC parameter on the system controller setup menu.

5. Electronic Sensitivity Enhancement (SENS UP)



There are two modes for SENS UP.

AUTO: If you select x32 AUTO, for example, the sensitivity is raised automatically to x32 max. When AUTO is selected, AGC is automatically set to ON.

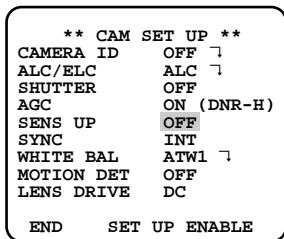
FIX: If you select x64 FIX, for example, the sensitivity is raised to just x64.



Move the cursor to the SENS UP parameter and select the parameter for electronic sensitivity enhancement.

The preset values for SENS UP (electronic sensitivity enhancement) change by pressing  or  as follows:

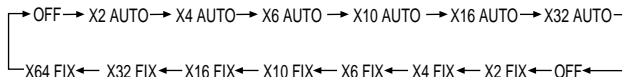

Notes:

- While the SENS UP function is selected, noise, spots or a whitish phenomenon may appear in the picture when the sensitivity of the camera is increased. This is a normal phenomenon.
- x64FIX does not appear for the SENS UP parameter on the system controller setup menu.
- In case of using the WV-CU204 or WV-CU254 Controller, status does not appear correctly for the SENS UP parameter on the setup menu.

6. Synchronization Setting (SYNC)

You can select internal sync mode (INT) or line-lock mode (LL). Additionally, this model accepts the VBS signal (color composite video or blackburst signal) and VS signal (B/W composite video or composite sync signal). The VD2 signal (multiplexed vertical drive signal) with the composite video output signal from external equipment such as a Matrix Switcher is also acceptable.

Whenever the VD2 signal is supplied to this camera, the camera automatically switches to the VD2 sync mode.

1. Move the cursor to the SYNC parameter and select line-lock(LL) or internal(INT).
2. Press .

If LL is selected, the SYNC menu appears. See page 31 (If INT is selected, the synchronization mode is automatically set to internal sync pulse, and the menu is not displayed.)

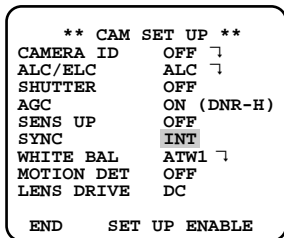

Important Notices:

1. The priority for the sync modes is as follows.
 1. Multiplexed Vertical Drive (VD2) (Highest priority)
 2. Line-lock (LL)
 3. Color Composite Video or Blackburst Signal (VBS)
 4. B/W Composite Video or Composite Sync Signal (VS)
 5. Internal Sync (INT) (Lowest priority)
2. When the internal sync mode is to be used, select INT. No gen-lock input signal should be supplied to the Gen-lock Input Connector on the rear panel.
3. Whenever the multiplexed vertical drive pulse (VD2) is supplied to the camera from an external equipment such as a Matrix Switcher, the camera sync mode is automatically switched to the VD2 mode.
4. When the VBS or VS gen-lock mode is to be used select INT from this menu and supply the gen-lock input signal to the Gen-lock Input Connector on the rear panel.
5. The VBS gen-lock mode has a submenu for horizontal and subcarrier phase adjustments. When the cable length of the video output or the gen-lock input is changed, the horizontal and subcarrier phase must be re-adjusted.

- The VS gen-lock mode has a submenu for horizontal phase adjustments. When the cable length of the video output or the gen-lock input is changed, the horizontal phase must be re-adjusted.
- The line-lock mode has a submenu for line-lock vertical phase adjustment. If the camera installation is relocated, check the vertical phase adjustment again since the AC line phase may be different.





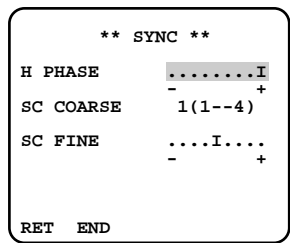
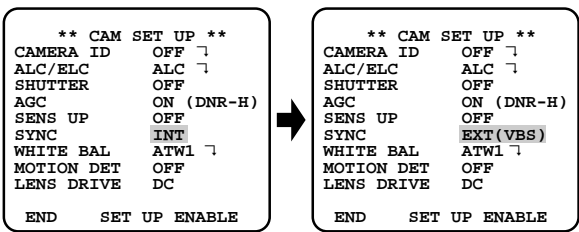

- Confirm that the INT parameter changed to EXT (VBS) on the menu.
Caution: The gen-lock input signal should meet the EIA RS-170A specifications and should not contain jitter, such as a VCR playback signal, as it could disturb synchronization.
- After confirming that the cursor is on EXT (VBS), press . The phase adjustment menu appears on the monitor.

6-1. VBS Gen-lock Mode (EXT(VBS))





- Move the cursor to the SYNC parameter and select INT.
- Connect the coaxial cable for the blackburst or composite color video signal to the gen-lock input connector.

- Supply the video output signal of the camera to be adjusted and the reference gen-lock input signal to a dual-trace oscilloscope.
- Set the oscilloscope to the horizontal rate and expand the horizontal sync portion on the oscilloscope.
- Move the cursor to H PHASE.

8. Adjust the horizontal phase by pressing  or . The adjustable range is 0 - 2.0μs.
9. Move the cursor to SC COARSE.
10. Press  or  to match the chroma phase of the camera's video signal, when observed at the output of the Special Effect Generator (SEG) or Switcher, as closely as possible to the color of the original scene. (SC COARSE adjustment can be incremented in steps of 90 degrees (4 steps) by pressing  or .)

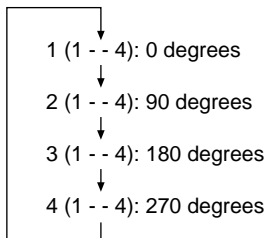



Note: After the fourth step, the adjustment returns to the first step.



11. Move the cursor to SC FINE.
12. Press  or  to match the color (hue) of the camera's video signal, when observed at the output of the Special Effect Generator (SEG) or Switcher, as closely as possible to the color of the original scene.

The SC FINE adjustment has a range of 90 degrees of color shift.

Notes:

- When the "I" cursor reaches the "+" end, it jumps back to "-" . At the same time, SC COARSE is incremented by one step to enable a continuous adjustment. The reverse takes place when the "I" cursor reaches the "-" end.
- When  or  is kept pressed for a second or more, the "I" cursor moves faster.
- For more accurate adjustment, supply both the original camera video output signal and the effect output video signal (program output video signal) of the special effects generator (SEG) to a vectorscope and compare the chroma phase of both signals.
- To reset SC COARSE and SC FINE to the values preset at the factory, press  and  simultaneously.

6-2. VS Gen-lock Mode (EXT(VS))

1. Move the cursor to the SYNC parameter and select INT.
2. Connect the coaxial cable for the composite sync or composite B/W video signal to the gen-lock input connector.
3. Confirm that the parameter INT changed to EXT (VS) on the menu.

Caution: The gen-lock input signal should meet with EIA RS-170 specifications and should not contain jitter, such as a VCR playback signal , as it could disturb synchronization.

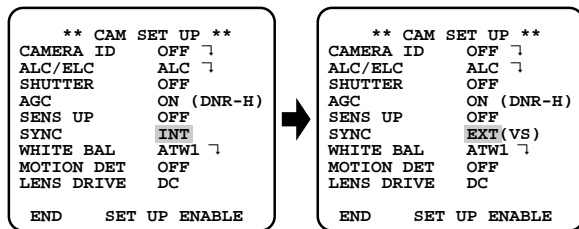

4. After confirming that the cursor is on EXT (VS), press . The phase adjustment menu appears on the monitor.

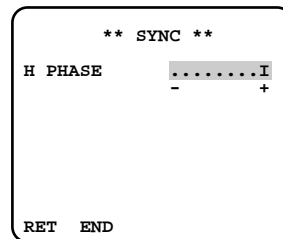

5. Supply the video output signal of the camera to be adjusted and the reference gen-lock input signal to a dual-trace oscilloscope.
6. Set the oscilloscope to the horizontal rate and expand the horizontal sync portion on the oscilloscope.
7. Move the cursor to H PHASE.
8. Adjust the horizontal phase by pressing or . The adjustable range is 0 - 2.0μs.

6-3. Line-lock Sync Mode (LL)

Note: The line-lock (LL) sync mode is not available when the camera operates on DC power.

1. Move the cursor to the SYNC parameter and select LL.

Note: The settings in this menu can be made only when the multiplexed vertical drive signal (VD2) is not supplied to the camera.

- After confirming the cursor is on LL, press . The vertical phase adjustment menu appears on the monitor.

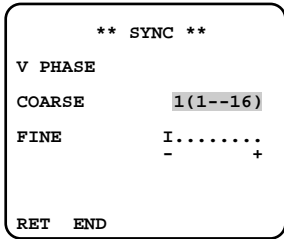

- Supply the video output signal of the camera to be adjusted and the reference camera video output signal to a dual-trace oscilloscope.
- Set the oscilloscope to the vertical rate and expand the vertical sync portion on the oscilloscope.
- Move the cursor to COARSE. The cursor starts blinking.
- Press or to match the vertical phase for both video output signals as closely as possible. (COARSE adjustment can be incremented in 16 steps by 22.5 degrees by pressing or .)

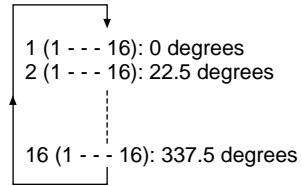



Note: After the sixteenth step, the adjustment returns to the first step.

- Move the cursor to FINE.
- Press or to match the vertical phase for both video output signals as closely as possible. (FINE adjustment can be made up to 22.5 degrees by pressing or .)

Notes:

- When the "I" cursor reaches the "+" end, it jumps back to "-". At the same time, COARSE is incremented by one step to enable a continuous adjustment. The reverse takes place when the "I" cursor reaches the "-" end.
- When or is kept pressed for a second or more, the "I" cursor moves faster.

- To reset COARSE and FINE to the values preset at the factory, press  and  simultaneously. COARSE and FINE adjustments are preset at the factory to zero-crossing of the AC line phase.
- If the AC line contains noise (spike noise, etc.), the stability of the vertical phase of the camera video output signal may be disturbed.

7. White Balance Setting (WHITE BAL)

7-1. Auto-Tracing White Balance Mode (ATW)

You can select one of four modes for white balance adjustment as follows:

- **ATW1 (Auto Tracing White Balance 1)**

In this mode, the color temperature is monitored continuously and thereby white balance is set automatically. The color temperature range for the proper white balance is approximately 2 600 - 6 000K. Proper white balance may not be obtained under the following conditions:

1. The color temperature is out of the 2 600 - 6 000K range.
2. When the scene contains mostly high color temperature objects, such as a blue sky or sunset.
3. When the scene is dim.

In these cases, select the AWC mode.

Move the cursor to the WHITE BAL parameter and select ATW1. The white balance of the camera is automatically set.

```

** CAM SET UP **
CAMERA ID    OFF ↵
ALC/ELC     ALC ↵
SHUTTER      OFF
AGC          ON (DNR-H)
SENS UP     OFF
SYNC        INT
WHITE BAL   ATW1 ↵
MOTION DET  OFF
LENS DRIVE  DC
END        SET UP ENABLE

```

- **ATW2 (Auto Tracing White Balance 2)**

Auto-tracing white balance of the sodium light mode (ATW2)

In case that you select ATW2 for sodium light, white balance is set automatically (Operation is not needed).

Note: ATW1 and ATW2 do not appear for the WHITE BAL parameter on the system controller setup menu.

- **Automatic White Balance Control Mode (AWC)**

In this mode, accurate white balance is obtained within a color temperature range of approximately 2 300-10 000K.

1. Move the cursor to the WHITE BAL parameter and select AWC → PUSH SW.

```

** CAM SET UP **
CAMERA ID   OFF  ↵
ALC/ELC    ALC  ↵
SHUTTER     OFF
AGC         ON (DNR-H)
SENS UP     OFF
SYNC       INT
WHITE BAL   AWC-PUSH SW
MOTION DET OFF
LENS DRIVE DC

END      SET UP ENABLE
  
```

2. Press  to start the white balance setup. The PUSH SW is highlighted to indicate that the white balance is being set.

```



** CAM SET UP **
CAMERA ID   OFF  ↵
ALC/ELC    ALC  ↵
SHUTTER     OFF
AGC         ON (DNR-H)
SENS UP     OFF
SYNC       INT
WHITE BAL   AWC-PUSH SW
MOTION DET OFF
LENS DRIVE DC

END      SET UP ENABLE
  
```

Highlighted

3. When the white balance setting is completed, the PUSH SW returns to normal display.

Note: In case that the white balance is not set, the PUSH SW is being highlighted.

4. When you want to adjust the white balance manually, press  to select AWC and press . The AWC menu appears on the monitor. (When ATW is selected, pressing  displays the ATW menu.)

```

** CAM SET UP **
CAMERA ID   OFF  ↵
ALC/ELC    ALC  ↵
SHUTTER     OFF
AGC         ON (DNR-H)
SENS UP     OFF
SYNC       INT
WHITE BAL   AWC  ↵
MOTION DET OFF
LENS DRIVE DC

END      SET UP ENABLE
  
```



```



** AWC **
R          ....I....
-          +
B          ....I....
-          +



MASK SET  ↵

RET END
  
```

Manual Fine Adjustment for AWC (ATW)

You can set the white balance items manually.

1. To set MASK SET, proceed as described in steps 2 to 4 of "ALC mode with PRESET OFF" (See page 24 and 25).
2. Move the cursor to R.
3. Press  or  to obtain the optimum amount of red gain.
4. Move the cursor to B.

5. Press  or  to obtain the optimum amount of blue gain.

Note: When you need to set MASK SET, re-adjust to obtain the optimum amount of red and blue gain.

8. Motion Detector Setting (MOTION DET)

The motion detector detects the moving objects in the scene by monitoring changes in brightness level. You can select the level of sensitivity for motion detection.

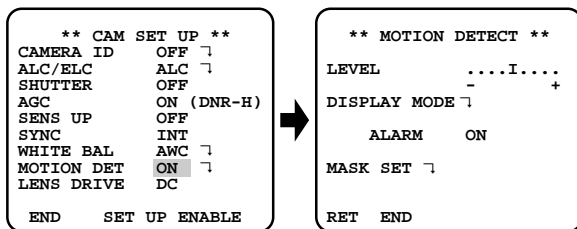

When this camera is connected to a compatible intelligent CCTV system, the camera transmits an alarm signal by multiplexing it with the video signal.

1. Move the cursor to the MOTION DET parameter and select ON.
2. Press . The MOTION DETECT menu appears on the monitor screen.



3. Move the cursor to MASK SET and press . MASK SET lets you set 48 mask areas. To set MASK SET, proceed as described in steps 2 to 4 of "ALC mode with PRESET OFF" (See page 24 and 25).
4. Move the cursor to the ALARM parameter and select ON or OFF to set the alarm for DISPLAY MODE.

Note: When the system controller WV-RM70, WV-CU550 series, WV-CU161 or WV-CU360 is used with this model, select OFF for ALARM.

5. Move the cursor to DISPLAY MODE and press  to see the current setting. The masks that detect the brightness changes start blinking.
6. To raise detection sensitivity, press  to return to the MOTION DETECT menu.
7. To obtain the optimum detection level, move the "I" cursor to adjust the level.
8. Repeat the procedures above to obtain a satisfactory setting.

Notes:

- Masking or adjusting the detection level is needed to prevent malfunction under the following conditions:
- When shooting an object under flickering fluorescent light or shooting in ELC.
- When leaves or curtains etc. are swayed by the wind.
- When the object is lighted by lighting equipment that constantly turns on and off.
- It takes about 0.2 seconds for the alarm signal to reach the alarm terminal of the VCR after the camera detects the object.

Because the alarm signal is multiplexed on the video signal, it may be mistakenly interpreted by other video equipment as a time code signal.

Therefore, when the camera is not used in a Panasonic Intelligent CCTV System, select OFF to prevent the above from occurring.

9. Lens Drive Signal Selection (LENS DRIVE)



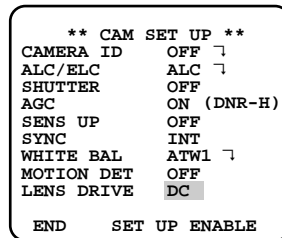

This item is used to select the type of auto iris lens drive signal to be supplied to the lens from the auto iris lens connector.



1. Move the cursor to the LENS DRIVE parameter.
2. Select DC if you are using the auto iris lens that requires a DC drive signal.
Select VIDEO if you are using the auto iris lens that requires a video drive signal.

10. Special Menu (SPECIAL)

This menu lets you adjust and set up the video signal of the camera to meet your requirements.

Move the cursor to END on the bottom line of the CAM SET UP menu and press  and  simultaneously (hold down  and press ) for 2 seconds or more. The SPECIAL menu appears on the monitor as shown below.

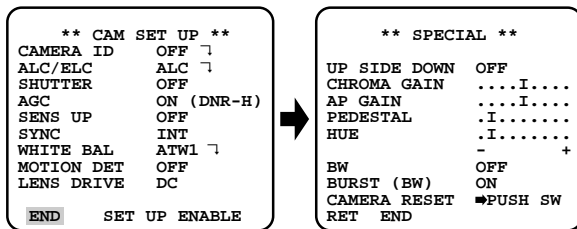

10-1. Camera Picture Upside Down Positioning (UP SIDE DOWN)

1. Move the cursor to the UP SIDE DOWN parameter.
2. Select ON when you want to turn the picture upside down.

10-2. Chroma Level Setting (CHROMA GAIN)

1. Move the cursor to the CHROMA GAIN parameter.
2. While observing the vectorscope or color video monitor, move the "I" cursor to adjust the chroma level.

10-3. Aperture Gain Setting (AP GAIN)

1. Move the cursor to the AP GAIN parameter.
2. While observing the waveform monitor or color video monitor, move the "I" cursor to adjust the aperture gain level.



10-4. Pedestal Level Setting (PEDESTAL)

1. Move the cursor to the PEDESTAL parameter.
2. While observing the waveform monitor or color video monitor, move the "I" cursor to adjust the pedestal level (black level).

10-5. Chroma Phase (Hue) Setting (HUE)

1. Move the cursor to the HUE parameter.
2. While observing the vectorscope or color video monitor, move the "I" cursor to adjust the hue (chroma phase) level.

10-6 BW

1. Move the cursor to the BW parameter.
2. Select AUTO1, AUTO2, ON or OFF using  or .

Default: OFF

AUTO1: The camera selects black and white mode if the picture is dark, or color mode if the picture is bright enough.

Note: Color picture switches to black-and-white picture and vice versa in approximately 1 or 2 minutes after recognition of illuminance.

AUTO2: Applying AUTO1 may cause malfunction when using a source of near-infrared light at night because the illuminance changes significantly when switching between the color picture and the black-and-white picture. But AUTO2 allows the unit to prevent malfunction because it simply recognizes a source of light.

Note: Because a source of light is simply recognized based on the information from CCD image pickup element, an object sometimes can not be recognized successfully when the object is always moving or the object and its background have the same color.

When you apply this mode, AUTO2, the wavelength of the light source should be 800 nm or more.

ON: Black and white mode is selected.

OFF: Color mode is selected.

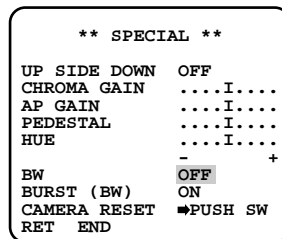

10.7 BURST (BW)

1. Move the cursor to the BURST (BW) parameter.
2. Select ON or OFF using or .

Default: ON



ON: The burst signal is supplied along with the black and white composite video signal.

OFF: The burst signal is not output.

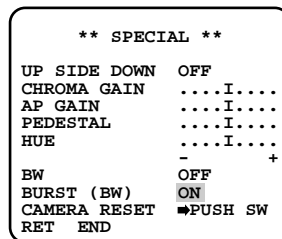
Note: We recommend that you usually select ON.



To reset to the factory settings

1. Move the cursor to the CAMERA RESET parameter. PUSH SW is highlighted.
2. While holding down  and , press  for 2 seconds or more. The camera is reset to the factory settings.

PREVENTION OF BLOOMING AND SMEAR

When the camera is aimed at a bright light, such as a spotlight, or a surface that reflects bright light, smear or blooming may appear. To avoid smear and blooming the camera should be operated carefully in the vicinity of extremely bright objects.

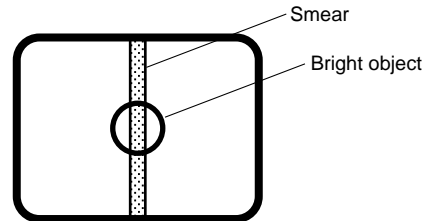

SPECIFICATIONS

Pick-up Device:	768 (H) x 494 (V) pixels, Interline Transfer CCD
Scanning Area:	6.45 (H) x 4.84 (V) mm (Equivalent to scanning area of 1/2" pick-up tube)
Scanning:	525 lines/60 fields/30 frames
Horizontal:	15.734 kHz
Vertical:	59.94 Hz
Synchronization:	Internal, Line-locked, External (VS/VBS) or Multiplexed Vertical Drive (VD2) selectable
Video Output:	1.0 V[p-p] NTSC composite 75 Ω /BNC connector
Horizontal Resolution:	480 lines (C/L), 570 lines (B/W)
Signal-to-Noise Ratio:	50 dB (AGC OFF, weight ON)
Minimum Illumination:	0.3 lx (0.03 footcandle) at F1.4 (C/L), 0.02 lx (0.002 footcandle) at F1.4 (B/W)
Gain Control:	AGC ON or OFF (SET UP MENU) selectable
White Balance:	ATW1, ATW2 or AWC (SET UP MENU) selectable
Aperture:	Variable (SET UP MENU)
Electronic Light Control:	Equivalent to continuous variable shutter speeds between 1/60 s and 1/10 000 s
AGC:	ON (DNR-H), ON (DNR-L) or OFF (SET UP MENU) selectable
Backlight Compensation:	Preset ON or OFF (SET UP MENU) selectable
Electronic Shutter Speed:	1/60 (OFF), 1/100, 1/250, 1/500, 1/1 000, 1/2 000, 1/4 000, 1/10 000 s selectable
Lens Mount:	CS-mount
ALC Lens:	DC or Video selectable
Ambient Operating Temperature:	-10°C - +50°C (14°F - 122°F)
Ambient Operating Humidity:	Less than 90 %
Power Source and	WV-CL920: 120 V AC 60 Hz 4.8 W
Power Consumption:	WV-CL924: 24 V AC 60 Hz 4.9 W
	12 V DC 460 mA

Dimensions (without lens): 74 mm (W) x 55 mm (H) x 120 mm (D)
[2-15/16" (W) x 2-3/16" (H) x 4-13/16" (D)]
Weights (without lens): WV-CL920: 0.45 kg (1.0 lbs.) (without power cord)
WV-CL924: 0.44 kg (1.0 lbs.)

Weights and dimensions indicated are approximate.
Specifications are subject to change without notice.

STANDARD ACCESSORIES

Body Cap	1 pc.
ALC Lens Connector (YFE4191J100)	1 pc.
AC Power Cord (only WV-CL920)	1 pc.
C-mount Adapter	1 pc.

OPTIONAL ACCESSORIES

Lenses : WV-LA2.8, WV-LA4R5A, WV-LA6A, WV-LA12A, WV-LZ80/2, WV-LZ81/10, WV-LZ81/6A, WV-LA4510, WV-LA608, WV-LA1208

Panasonic Security and Digital Imaging Company
A Division of Matsushita Electric Corporation of America

Executive Office: One Panasonic Way 3E-7, Secaucus, New Jersey 07094

Regional Offices:

Northeast: One Panasonic Way, Secaucus, NJ 07094 (201) 348-7303

Southern: 1225 Northbrook Parkway, Suite 1-160, Suwanee,
GA 30024 (770) 338-6838

Midwest: 1707 North Randall Road, Elgin, IL 60123 (847) 468-5211

Western: 6550 Katella Ave., Cypress, CA 90630 (714) 373-7840

Panasonic Canada Inc.

5770 Ambler Drive, Mississauga,
Ontario, L4W 2T3 Canada (905)624-5010

Panasonic Sales Company

Division of Matsushita Electric of Puerto Rico Inc.

Ave. 65 de Infanteria. Km. 9.5
San Gabriel Industrial Park, Carolina,
Puerto Rico 00985 (809)750-4300