



# User Guide

**TXT8010**

**CHAPTER 1. BEFORE USING TXT8010**

INSIDE THE PACKAGE.....	6
HANDSET DESCRIPTIONS .....	7
KEYS DESCRIPTIONS.....	8
DISPLAY INDICATORS .....	9
INSTALL/REMOVE BATTERY.....	11
CHARGING YOUR BATTERY .....	11
BATTERY HANDLING INFORMATION.....	12

**CHAPTER 2. BASIC OPERATION**

TURNING THE PHONE ON/OFF .....	14
ACCESSING THE MENU .....	14
MENU SUMMARY .....	15
MAKING A CALL .....	17
ANSWERING CALLS .....	17
MISSED CALL NOTIFICATION .....	17
WAIT/PAUSE FEATURE .....	18

ANSWERING A CALL .....	18
MAKING AN INTERNATIONAL CALL .....	18
3-WAY CALLING .....	18
CALL WAITING FUNCTION .....	19
CALLING A NUMBER FROM CONTACTS .....	19
ADJUSTING VOLUME.....	19
ADJUSTING THE CALL VOLUME .....	19
CALLER ID FUNCTION .....	20
VIBRATE ON/OFF MODE .....	20
SPEAKER PHONE MODE .....	20
USING AUTO KEYPAD LOCK FUNCTION .....	20
AVAILABLE OPTIONS DURING A CALL.....	20
MAKING AN EMERGENCY CALL.....	21

**CHAPTER 3. MEMORY FUNCTION**

STORING A PHONE NUMBER .....	24
ENTERING LETTERS, NUMBERS & SYMBOLS .....	25

ONE-TOUCH/TWO-TOUCH DIALING .....	26
-----------------------------------	----

**CHAPTER 4. MENU FUNCTION**

NEW CONTACT .....	28
CONTACT LIST .....	28
GROUPS .....	29
SPEED DIALS.....	30
IN CASE OF EMERGENCY .....	31
MY NAME CARD .....	32
MISSED .....	33
RECEIVED .....	33
DIALED.....	34
ALL .....	34
BLOCKED .....	35
VIEW TIMERS.....	35
BLUETOOTH .....	36
SOUNDS SETTINGS .....	37

DISPLAY SETTINGS .....	39
PHONE SETTINGS .....	41
CALL SETTINGS .....	45
MEMORY .....	46
PHONE INFO .....	46
VOICE COMMANDS .....	48
CALCULATOR.....	53
CALENDAR.....	53
ALARM CLOCK.....	55
WORLD CLOCK .....	55
NOTEPAD.....	56
STOP WATCH.....	57
MY ACCOUNT .....	58

**CHAPTER 5. MEDIA CENTER**

USING THE microSD CARD .....	60
MUSIC & TONES .....	61
PICTURES .....	64
GAMES .....	65
MOBILE WEB .....	66
BROWSE & DOWNLOAD .....	67

EXTRAS ..... 67  
 MEDIA CENTER INFO ..... 68

**CHAPTER 6. MESSAGING MENU**

WHEN A NEW MESSAGE ARRIVES ..... 70  
 NEW MESSAGE..... 70  
 INBOX ..... 72  
 SENT ..... 72  
 DRAFTS ..... 73  
 VOICEMAIL ..... 73  
 MOBILE IM ..... 74  
 E-MAIL ..... 75  
 CHAT ..... 75  
 ERASE ALL ..... 75  
 SETTINGS ..... 75

**CHAPTER 7. SAFETY AND WARRANTY**

SAFETY INFORMATION FOR WIRELESS HANDHELD PHONES ..... 78  
 SAFETY INFORMATION FOR FCC RF EXPOSURE ..... 81  
 SAR INFORMATION ..... 81  
 FCC HEARING-AID COMPATIBILITY (HAC) REGULATIONS FOR WIRELESS

DEVICES ..... 82  
 FDA CONSUMER UPDATE..... 84  
 AVOID POTENTIAL HEARING LOSS..... 88  
 12 MONTH LIMITED WARRANTY..... 90  
 INDEX LIST ..... 92

CHAPTER 1

**BEFORE USING TXT8010**

This chapter provides important information about using the  
 TXT8010 including:

- Inside the package
- Handset description
- Keys description
- Display indicators
- Install/Remove battery
- Charging your battery
- Battery handling information

## INSIDE THE PACKAGE

This package should include all items pictured below. If any are missing or different, immediately contact the retailer where you purchased the phone.



Handset



Standard Battery



User Guide



Travel Charger



Headset Adaptor with Charging Port



Headset must be connected to Headset Adaptor with Charging Port when you use it.

## HANDSET DESCRIPTIONS

The TXT8010 weighs 2.96oz. and the dimensions are 1.86" x 3.65" x 0.78".

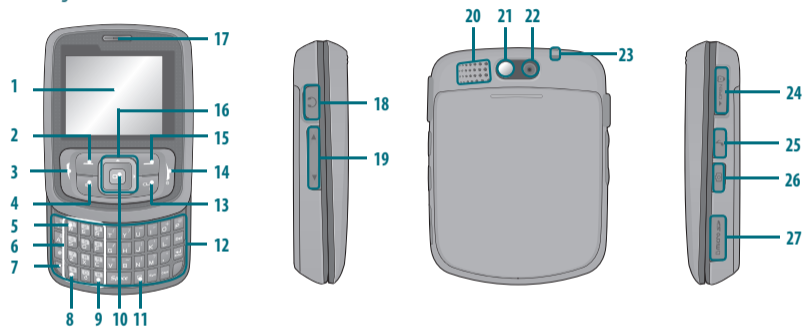

- |                     |                             |                      |                       |
|---------------------|-----------------------------|----------------------|-----------------------|
| 1. Display Screen   | 8. International Dial Key   | 15. Right Soft Key   | 22. Camera Lens       |
| 2. Left Soft Key    | 9. Manner Mode Key          | 16. Navigation Key   | 23. Strap Hole        |
| 3. SEND Key         | 10. Menu/OK Key             | 17. Ear Speaker      | 24. Charger Jack      |
| 4. Speakerphone Key | 11. My Messaging Key        | 18. Headset Jack     | 25. Music Key         |
| 5. Voicemail Key    | 12. QWERTY Keyboard         | 19. Side Volume Key  | 26. Camera Key        |
| 6. Dialing Keypad   | 13. CLR or AVR Key          | 20. External Speaker | 27. microSD Card Slot |
| 7. Microphone       | 14. END or Power On/Off Key | 21. Camera Mirror    |                       |

## KEYS DESCRIPTIONS



The following list correlates to the previous page's phone illustration.









1. **Display Screen:** This screen displays all the information needed to operate your phone.
2. **Left Soft Key:** Press to access the message menu or function displayed on bottom line.
3. **SEND Key:** Press to make or receive a call.
4. **Speakerphone Key:** Press to turn Speaker Phone On or Off.
5. **Voicemail Key:** Press and hold to automatically dial your voicemail.
6. **Dialing Keypad:** In idle mode, press to enter phone numbers using a dialing keypad interface.
7. **Microphone:** Allows the other caller to hear you clearly when you are speaking to them.
8. **International Dial Key:** To enter an international dialing prefix (+).
9. **Manner Mode Key:** Press and hold to place your device in manner mode.
10. **Menu/OK Key:** Allows you to access the menu screen. It also allows you to accept choices when navigating through a menu.









11. **My Messaging Key:** Press to access My Messaging menu.
12. **QWERTY Keyboard:** Press to enter numbers, letters, and characters using a full Qwerty keypad interface.
13. **CLR or AVR Key:** Press to clear a digit from the display or to return to the previous page. In idle mode, press and hold to activate VoiceSignal™.
14. **END or Power On/Off Key:** Press to turns the phone on and off, ends a call or browser session, and returns you to the idle mode.
15. **Right Soft Key:** Press to access contacts menu or function displayed on bottom line.
16. **Navigation Key:** The Navigation Keys allows you to scroll through phone menu options and provides a shortcut to phone functions from standby mode.
17. **Ear Speaker:** The earpiece allows you to hear the other caller.
18. **Headset Jack:** Plug in the Headset Interface Connector here to use a headset.
19. **Side Volume Key:** Allows you to adjust the master volume in standby mode or adjust the voice volume during a call.

20. **External Speaker:** Music, Ringtones, and Sounds are played through the speaker.
21. **Camera Mirror:** Displays your reflection when taking pictures.
22. **Camera Lens:** The lens of your built-in camera.
23. **Strap Hole:** Accessory eyelet (for optional straps and lanyards).
24. **Charger Jack:** Plug in the Travel Charger Interface Connector here to use a headset.
25. **Music Key:** In idle mode, press to activates BGM or MOD player.
26. **Camera Key:** Press to turn on camera viewfinder mode.
27. **microSD Card Slot:** Your phone has an external memory port for a microSD card.





## DISPLAY INDICATORS

Icon	Icon Discriptions
	<b>EV Signal Strength:</b> The EV service mode indicator shall display with/without a progress bar when a 1x-EVDO device has only acquired 1x-EVDO service.
	<b>1X Signal Strength:</b> The 1X signal strength indicators shall display with/without a progress bar when a 1x-RTT CDMA2000 services.

	<b>D Signal Strength:</b> The D signal strength indicators shall display with/without a progress bar when a CDMA IS-95 service.
	<b>EV &amp; 1X Signal Strength:</b> The EV and 1X signal strength indicators shall display with/without a progress bar when a 1x-EVDO device has acquired both 1x-RTT CDMA2000 and 1x- EVDO services.
	<b>EV &amp; D Signal Strength:</b> The EV and D signal strength indicators shall display with/without a progress bar when a 1x-EVDO device has acquired both 1x-EVDO service and CDMA IS-95 service.
	<b>Standalone:</b> Transmitting and receiving information is restricted.
	<b>Roaming:</b> Phone is out of home area.
	<b>Voice Icon</b>
	<b>Data Active Icon</b>
	<b>Dormant:</b> Phone is in a dormant state during a data call. Phone reverts to Dormant mode when there hasn t been activity on a page for some time — the connection is still active and you can make and receive calls.

	<b>No Service:</b> Phone cannot receive a signal from the system.
	<b>GPS Icon:</b> Location Service of your phone is disabled/enabled.
	<b>Voice Privacy:</b> Indicates Voice Privacy mode.
	<b>SSL (Secured Socket Layer):</b> Indicating that secure communication between client and server has been established during data communication using encryption.
	<b>TTY:</b> TTY mode is active.
	<b>Bluetooth:</b> Indicates Bluetooth mode.
	<b>Bluetooth Active:</b> Indicates Bluetooth Active mode.
	<b>Bluetooth Conn:</b> Indicates Bluetooth Connect.
	<b>BGM:</b> BGM mode is active.

	<b>Battery:</b> Battery charging level — the more blocks, the stronger the charge.
	<b>Keylock:</b> Indicates phone is locked.
	<b>New Message:</b> Indicates you have new message.
	<b>Voicemail:</b> Indicates you have voicemail messages.
	<b>Missed Calls:</b> Indicates you have missed calls.
	<b>Calendar Appointment:</b> Event Alarm is active.
	<b>Speaker Phone:</b> Phone is in Speaker Phone mode.
	<b>Alarm:</b> Appears when an alarm is set.
	<b>All Sounds Off:</b> Ringer volume is set to off.

	<b>Alarm Only:</b> Phone will alert you with an alarm tone.
	<b>Vibrate Only:</b> Phone will vibrate when call is received.
	<b>AVR Active:</b> AVR mode is active.
	<b>AVR Listening:</b> Indicates AVR listening.

## INSTALL/REMOVE BATTERY

1. Remove the battery cover from the unit.
2. Slide the battery into the slot located at the bottom of the unit and press until you hear the "click".



3. To remove the battery, push down on the top of the battery and slide it out.



4. Slide the battery cover back into the unit.



 If the battery is not correctly placed in the compartment, the handset will not turn on and/or the battery may detach during use.

## CHARGING YOUR BATTERY

1. To charge open the protective cover on the Right Side and connect the charger adapter. Plug the other end into a standard outlet.



2. To remove the adapter connection press the adapter's side buttons (1) and pull.



- When you charge the battery with the phone power off, you will see a charging status screen. You cannot operate the phone until it is powered on.
- The battery is not charged at the time of purchase.
- Fully charge the battery before use.
- It is more efficient to charge the battery with the handset powered off.
- The battery must be installed in the phone in order to charge it.
- Battery operating time gradually decreases over time.
- If the battery fails to perform normally, you may need to replace the battery.

## BATTERY HANDLING INFORMATION

### DO'S

- Only use the battery and charger approved for use with the CDM8960.
- Only use the battery for its original purpose.
- Try to keep batteries in a temperature between 41 °F (5 °C) and 95 °F (35 °C). If the battery is stored in temperatures above or below the recommended range, give it time to warm up or cool down before using.

- Completely drain the battery before recharging.
- Store the discharged battery in a cool, dark, and dry place.
- Purchase a new battery when its operating time gradually decreases after fully charging.
- Properly dispose of the battery according to local laws.

### DON'TS

- Don't attempt to disassemble the battery – it is a sealed unit with no serviceable parts.
- Don't accidentally short circuit the battery by carrying it in your pocket or purse with other metallic objects such as coins, clips and pens. This may critically damage the battery.
- Don't leave the battery in extremely hot or cold temperatures. Otherwise, it could significantly reduce the capacity and lifetime of the battery.
- Don't dispose of the battery by placing into fire.

## CHAPTER 2 BASIC OPERATION

This chapter addresses and explains the basic features of your phone including:

Turning the phone on/off	Call waiting function
Accessing the menu	Calling a number from contacts
Menu summary	Adjusting volume
Making a call	Adjusting the call volume
Answering calls	Caller ID function
Missed call notification	Vibrate on/off mode
Wait/Pause feature	Speaker phone mode
Answering a call	Using auto keypad lock function
Making an international call	Available options during a call
3-way calling	Making an emergency call

## TURNING THE PHONE ON/OFF

### TURNING THE PHONE ON

1. Press and hold **END Key** until your Power On logo appears on your internal display and the tone sounds.



- If "Enter Lock Code" appears on the display enter your 4-digit lock code to unlock your phone.
- Your default lock code is the last 4-digits of your Mobile Telephone Number.

### TURNING THE PHONE OFF

1. Press and hold **END Key** until your Power Off logo appears on the internal display.



- Immediately change or recharge the battery when "BATTERY LOW" appears on the display. Memory may possibly be damaged if the phone turns off due to the battery completely draining.
- Turn the phone off before removing or replacing the battery. If the phone is on, unsaved data may be lost.

## ACCESSING THE MENU

Your phone can be customized via the menu. Each function can be accessed by scrolling with the Navigation Key or by pressing the number that corresponds with the menu item.

1. To access the menu in idle mode, press **MENU**.
2. To scroll through the menu, press the Navigation Key up, down, left or right.
3. To return to the previous page, press **CLR Key**. To exit the current menu and return to the idle mode, press **END Key**.
4. Press **OK** to enter a function when its main page is displayed or press its assigned number to have direct access to the function.

## MENU SUMMARY

Main Menu	2 <sup>ND</sup> DEPTH	3 <sup>RD</sup> DEPTH
1. Media Center	1. Music & Tones  2. Pictures  3. Games 4. Mobile Web 5. Browse & Download  6. Extras	1. Get New Ringtones 2. My Ringtones 3. My Music 4. My Sounds 5. Sync Music 1. Get New Pictures 2. My Pictures 3. Take Picture 4. PIX Place  1. Get New Applications 2. VZ Navigator 1. Get New Applications
2. Messaging	1. New Message  2. Inbox 3. Sent 4. Drafts 5. Voicemail	1. TXT Message 2. Picture Message 3. Voice Message
2. Messaging	6. Mobile IM 7. E-mail 8. Chat Settings  Options	1. Entry Mode 2. Auto Save 3. Auto Erase 4. TXT Auto View 5. Pic-Voice Auto Receive 6. Quick Text 7. Voicemail # 8. Callback # 9. Signature 1. Erase Inbox 2. Erase Drafts 3. Erase Sent 4. Erase All
3. Contacts	1. New Contact 2. Contact List 3. Groups 4. Speed Dials 5. In Case of Emergency 6. My Name Card	



Main Menu	2 <sup>ND</sup> DEPTH	3 <sup>RD</sup> DEPTH
4. Recent Calls	1. Missed 2. Received 3. Dialed 4. Blocked ("Blocked" displays only Call Restriction is set) 5. All 6. View Timers	
5. Settings&Tools	1. My Account 2. Tools          3. Bluetooth Menu 4. Sounds Settings	1. Voice Commands 2. Calculator 3. Calendar 4. Alarm Clock 5. World Clock 6. Notepad 7. Stop Watch 1. Add New Device 1. Call Sounds 2. Alert Sounds 3. Keypad Volume 4. Service Alerts 5. Device Connect 6. Power On/Off

Main Menu	2 <sup>ND</sup> DEPTH	3 <sup>RD</sup> DEPTH
5. Settings&Tools	5. Display Settings	1. Banner 2. Backlight 3. Wallpaper 4. Display Themes 5. Main Menu 6. Dial Fonts 7. Clock Format
	6. Phone Settings	1. Standalone Mode 2. Set Shortcut Keys 3. Voice Commands 4. Language 5. Location 6. Security 7. System Select 8. NAM Selection
	7. Call Settings	1. Answer Options 2. Auto Retry 3. TTY Mode 4. One Touch Dial 5. Voice Privacy 6. DTMF Tones
	8. Memory	1. Save Options 2. Phone Memory 3. Card Memory

Main Menu	2 <sup>ND</sup> DEPTH	3 <sup>RD</sup> DEPTH
5. Settings&Tools	9. Phone Info	1. My Number 2. SW/HW Version 3. Icon Glossary 4. Software Update

## MAKING A CALL

1. Enter a phone number. > **SEND Key**.



- To erase one digit at a time press **CLR Key**.
- To erase the entire number, press and hold **CLR Key**.
- When you place or receive a call from phone numbers stored in your contact list with a contact name, the name will be displayed.

2. To end a call, press **END Key**.



- If "CALL FAILED" appears on the display or the line is busy, press **END Key** or **SEND Key**.
- If you activate the "AUTO RETRY" function, the phone will automatically re-dial the number (Refer to [page 45](#)).
- You can also place calls using Voice-Activated Dialing. Please refer to [page 48](#) for more details.
- If "Enter Lock Code" appears on the display enter your 4-digit lock code to unlock your phone.
- The default 4-digit lock code is the last 4 number of your mobile telephone number.

## ANSWERING CALLS

1. When your phone rings or vibrates, press **SEND Key** to answer the incoming call. (Depending on your phone's settings, you may also answer incoming calls by opening the phone or by pressing any key.)



To ignore incoming calls, press Right Soft Key **Ignore**.

2. To end a call, press **END Key**.



In Auto Answer Mode a call is automatically answered after a preset number of ring tones.

## MISSED CALL NOTIFICATION

When an incoming call is not answered, the Missed Call log is displayed on your screen.

### TO DISPLAY THE MISSED CALL ENTRY FROM THE NOTIFICATION SCREEN:

1. Highlight the entry "View Now" and press **OK**.
2. To dial the phone number, press **SEND Key**.

## TO DISPLAY A MISSED CALL ENTRY FROM STANDBY MODE:

1. Press **MENU**, then press the Navigation Key right once for the “Recent Calls” menu.
2. Press **1. Missed**.
3. Highlight the entry you wish to view, then press **Open**.
4. To dial the phone number, press **SEND Key**.

## WAIT/PAUSE FEATURE

Pauses are used for automated systems (i.e., voice mail, calling cards). Insert a pause after a phone number and then enter another group of numbers. The second set of numbers is dialed automatically after the pause. This feature is useful for dialing into systems that require a code.

1. To insert a wait/pause, enter a phone number and then press Right Soft Key **Options**. Select either 2-Sec Pause (“p”) or a Wait (“w”).
2. Press **SEND Key** to dial or Left Soft Key **Save**.

## ANSWERING A CALL

1. If your phone is set to “Slide Open” for “Answer Options,” simply open the phone to answer a call. If your phone is set to “Any Key” for “Answer Options,” press any key to answer a call except **END Key**, **Right Soft Key**, **CLR/Side AVR Key**, **Side Camera Key**, **Speaker Key**, **Side Volume Key** or **Left Soft Key**.
2. To end the call, press **END Key**.

## MAKING AN INTERNATIONAL CALL

1. Press and hold **\* Key**. The + required for international calls will be displayed.
2. Enter the country code, area code, and phone number, then press **SEND Key**.

## 3-WAY CALLING

With 3-Way Calling, you can talk to two people at the same time. When using this feature, the normal airtime rates will be applied for each of the two calls.

1. Enter the phone number you wish to call and then press **SEND Key**.

2. Once you have established the connection, enter the second phone number you wish to call and then press **SEND Key**.
3. When you’re connected to the second party, press **SEND Key** again to begin your 3-Way call.



If one of the people you called hangs up during your call, you and the remaining caller stay connected. If you initiated the call and are the first to hang up, all three CALLS are disconnected.

## CALL WAITING FUNCTION

Notifies you of an incoming call when you are already on a call by sounding a beep tone and displaying the caller’s phone number.

1. To answer another call while on the phone, press **SEND Key**. This places the first call on hold. To switch back to the first caller, press **SEND Key** again.



If one of the people you called hangs up during your call, you and the remaining caller stay connected. If you initiated the call and are the first to hang up, all three CALLS are disconnected.

## CALLING A NUMBER FROM CONTACTS

1. Press Right Soft Key **Contacts** to access the Contact List. Select the desired phone number and press **SEND Key**.

## ADJUSTING VOLUME

To adjust the master volume:

1. In idle mode, press the **Side Volume Key** up or down.
2. Select one of the following options and press **SET** to save it.
  - All Sounds Off
  - Alarms Only
  - Vibrate Only
  - Low / • Medium Low / • Medium / • Medium High / • High



Press the **Side Volume Key** up or down to adjust Earpiece volume during a call.

## ADJUSTING THE CALL VOLUME

During a call, if you want to adjust the earpiece volume, use the Volume Keys on the left side of the phone. Press the **Side Volume Key** up to increase the volume level and **Side Volume Key** down the key to decrease the level. In Idle mode, you can also adjust the ringer volume using these keys.

## CALLER ID FUNCTION

Identifies caller by displaying their phone number. If the caller's name and number are already stored in your contact list, name will appear. The caller ID is stored in the Recent Calls Menu.

## VIBRATE ON/OFF MODE

1. From the idle screen, press and hold the # Key.
2. To return to a previously set volume, from the idle screen press and hold # Key.

## SPEAKER PHONE MODE

The Speaker Phone feature lets you hear audio through the speaker and talk without holding the phone.

To activate the Speaker Phone in idle, mode or while on a call, press **Speaker Key**. If you press the **Speaker Key** when you are not on a call, speaker phone mode will be active for one minute, then turn itself off automatically.



When the speaker phone mode is on in the idle mode, the speaker phone mode will be off one minute later. When speaker phone mode is on in the idle mode, you make a call within one minute, the speaker phone mode will be off upon ending the call.

## USING AUTO KEYPAD LOCK FUNCTION

The slide is closed, touch keypad and navigation key are automatically locked. If you want to use touch keypad and navigation key, press and hold side any keys. > **OK**.

## AVAILABLE OPTIONS DURING A CALL

To display menu options during a call, press Right Soft Key **Options**.

### MESSAGING

(During a Call > Options > 1)

To send a message during a call.

### CONTACT LIST

(During a Call > Options > 2)

To select the phone number in your Contact List.

### RECENT CALLS

(During a Call > Options > 3)

To select the phone number in Recent Calls.

### BLUETOOTH MENU

(During a Call > Options > 4)

To access Bluetooth during a call.

## MAIN MENU

(During a Call > Options > 5)

To access the phone's main menu during a call.

Press the Navigation Key up, down, right or left to scroll through the menu screens.

## NOTEPAD

(During a Call > Options > 6)

To compose and store notes during a call.

## MAKING AN EMERGENCY CALL

The 911 feature automatically places the phone in the Emergency Call Mode when you dial the preprogrammed emergency number, 911. It also operates in the Lock Mode and out of the service area.

### 911 IN LOCK MODE

The 911 call service is available even in the Lock Mode.

1. Enter "911" and then press **SEND Key**.
2. The call connects.
3. The phone maintains the Emergency Mode for 5 minutes.

## 911 USING ANY AVAILABLE SYSTEM

The 911 call service is available even in the Lock Mode.

1. Enter "911" and then press **SEND Key**.
2. The call connects.
3. The phone will stay in Emergency Mode for 5 minutes. While the phone is in the Emergency Mode for 5 minutes, the phone can receive an incoming call from any available system or you can make outgoing calls even in the Emergency Callback Mode. In this case, making a call can automatically end the Emergency Callback Mode.



The 911 call is not recorded in the recent call list.

## MEMORY FUNCTION

This chapter addresses memory functions including:

- Storing a phone number
- Entering letters, numbers & symbols
- One-touch/Two-touch dialing

## STORING A PHONE NUMBER

The contact stores up to 1000 entries.

### ADDING A CONTACT THROUGH THE MENU

1. Press **MENU** > **1. New Contact**.
2. Enter a name for the entry using keypad. To change the input mode, press Left Soft Key **Abc**.
3. Press the Navigation Key down to add or edit other options.
  - **Contact Fields:** Name/ Mobile 1/ Home/ Work/ E-mail 1/ Group/ Picture/ Ringtone/ Mobile 2/ Fax/ E-mail 2.
  - Under " Mobile 1", " Mobile 2", " Home", " Work" or " Fax" input the phone number and then by pressing Right Soft Key **Options**, you can choose from the following: **1. Set Speed Dial/2. Set As Default/3. Add Pause**
4. To store the entry, press **SAVE**. "CONTACT SAVED" will be displayed.

### ADDING A CONTACT IN IDLE MODE

#### ADD NEW CONTACT

1. In idle Mode, enter phone number and press Left Soft Key **Save**.

2. Choose "**Add New Contact**", the phone number will appear above a list. Press the Navigation Key up or down to choose the type of number you're adding, as indicated by the icon. Press **OK** to select.
3. Enter a name for the entry using keypad. To change the input mode, press Left Soft Key **Abc**.
4. Press the Navigation Key down to add or edit other options.
  - **Contact Fields:** Name/ Mobile 1/ Home/ Work/ E-mail 1/ Group/ Picture/ Ringtone/ Mobile 2/ Fax/ E-mail 2.
  - Under " Mobile 1", " Mobile 2", " Home", " Work" or " Fax" input the phone number and then by pressing Right Soft Key **Options**, you can choose from the following: **1. Set Speed Dial/2. Set As Default/3. Add Pause**
5. To store the entry, press **SAVE**. "CONTACT SAVED" will be displayed.

#### UPDATE EXISTING

1. In idle Mode, enter phone number and press Left Soft Key **Save**.
2. Choose "**Update Existing**", your saved contact list is displayed. Choose the entry to add the phone number to, and then press **OK**. "CONTACT UPDATED" will be displayed.

## ENTERING LETTERS, NUMBERS & SYMBOLS

Your device has a specifically designed QWERTY keyboard that provides a superior typing experience on a small handheld for easy and comfortable input. You can use all of the handset functions with the keyboard either closed or open. When you open the keyboard you have the extra benefit of a full messaging keyboard.

The handheld includes a fully-functional QWERTY keyboard you can use to compose text for email messages, notes, and so on.

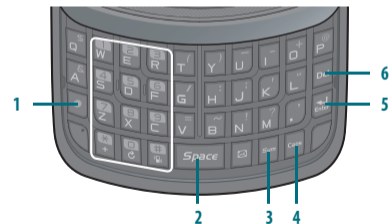

### 1. Mode Change Key:

- Press only **Mode Change Key** to change mode. [Abc][123]
- Press **Mode Change Key** + **Letter Key** to type the number or symbol printed in blue at the top of a key, hold down the blue-colored **Dot Key** and then press one or more letter keys. Alternatively, press and release the **Dot Key** and then press a letter key. To write in number or symbol printed in blue at the top of a key only, press the **Dot Key** twice.

**2. Space Key:** Press to accept a word and add a space.

**3. Symbols Key:** Press to open symbols list.

**4. Caps Key:** Press to select a letter case of the standard text input or text input mode. [Abc], [ABC] and [abc] indicate the standard text input.

**5. Enter Key:** Press the Enter key to insert a carriage return.

**6. Del Key:** Press to delete a character to the left of the cursor.



For best performance in low-light environments, your handset includes a backlight feature that can illuminate both the display and the keyboard so you can keep reading and typing.

## ONE-TOUCH/TWO-TOUCH DIALING

Ideal for frequently dialed numbers, this feature allows contact entries to be dialed via the keypad with only one or two key presses.

### ONE-TOUCH DIALING:

1-9 : Press and hold the number you wish to connect for more than 1 second.

### TWO-TOUCH DIALING:

10-22 : Press the first digit and second digits of the memory number short and long respectively.

97,98,99 : Pre-set numbers for Verizon Customer Service, and are free calls.

- **97 - #BAL:** The billing balance will read for you or sent in a text message.
- **98 - #MIN:** The minutes used will read for you or sent in a text message.
- **99 - #PMT:** Pay a bill with a one-time payment or other payment options.

## MENU FUNCTION

This chapter addresses accessing the menu and using its functions and features to customize your phone.

New contact	All	Phone info
Contact list	Blocked	Voice commands
Groups	View timers	Calculator
Speed dials	Bluetooth	Calendar
In case of emergency	Sounds settings	Alarm clock
My name card	Display settings	World clock
Missed	Phone settings	Notepad
Received	Call settings	Stop watch
Dialed	Memory	My Account

Stores up to 1000 entries, each of which can be assigned to a group. Entries can be retrieved by name or group.

## NEW CONTACT

(Menu > Contacts > 1)

Adds a new contact.

- To enter a name or number, press the Navigation Key up or down to select the contact field.

- Contact Fields:** Name/ Mobile 1/ Home/ Work/ E-mail 1/ Group/ Picture/ Ringtone/ Mobile 2/ Fax/ E-mail 2.
- Under " Mobile 1", " Mobile 2", " Home", " Work" or " Fax" input the phone number and then by pressing Right Soft Key **Options**, you can choose from the following: **1. Set Speed Dial/2. Set As Default/3. Add Pause**

- To save the entry, press **Save**.  
To return to the previous page, press **CLR Key**.



- For each new contact, at least 1 phone number or email address needs to be saved with the contact. "ADD AT LEAST ONE NUMBER OR E-MAIL ADDRESS" will be displayed if neither have been added.
- If the entry name is left empty and a phone number is provided, the entry will be saved and only the phone number will be displayed.

## CONTACT LIST

(Menu > Contacts > 2)

Retrieves an entry by name and calls by simply pressing Right Soft Key **Contacts**. You can review all the entries stored in your contact list or quickly find an entry by entering a name or its character string.

- The list of names in your contacts is displayed alphabetically.
- Enter a name or its character string or scroll through the list by pressing the Navigation Key up or down.
- To edit the entry, press Left Soft Key **Edit**. To show detail of the entry, press **View**.

Pressing Right Soft Key **Options**, you can choose from the following:

- New Contact:** To add a New Contact.
- Erase:** To delete a contact.
- New TXT Message:** To create a TXT message.
- New Picture Message:** To create a Picture message.
- New Voice Message:** To create a Voice message.
- Set As ICE Contact:** To set as emergency number.
- Call:** To call the contact.
- Erase All Contacts:** To delete all contact list.

- To call the selected number, press Right Soft Key **Options** and then select **Call** or press **SEND Key**.

## GROUPS

(Menu > Contacts > 3)

Groups allows you to classify phone entries into groups with up to 10 numbers in each group. The existing groups include No Group, Family and Work and they cannot be erased or renamed. You can add up to 27 more groups which can be changed or erased.

### TO ADD NEW GROUP

- Press Left Soft Key **New** > Input a new group name > **Save**.

### TO ASSIGN PHONE NUMBER TO GROUP

- Select the existing group name.
- To assign phone numbers to a Group, press the Right Soft Key **Options** > **Add** > **OK**.
- Your contact entries appear in alphabetical order. Select the contact you want to add by pressing the Navigation Key up or down > **Mark**.
- Press Left Soft Key **Done**. "CONTACT ADDED TO [GROUP NAME]" will be displayed. Repeat for each location for the Group.

### TO CHANGE GROUP NAME

- Press the Navigation Key up or down to select the existing group name that you want to change.
- Press Right Soft Key **Options** > **Rename**.
- Using the keypad enter the new group name > **Save**.

### TO SEND TXT MESSAGE TO A GROUP

- Press the Navigation Key up or down to select the existing group name that you want to change.
- Press Right Soft Key **Options** > **New TXT Message**.
- Input a "Text", and then press Right Soft Key **Options** to select "Save As Draft", "Add", "Edit Text Format", "Priority Level" and "Cancel Message".
- To send the TXT message, press **Send**.

### TO SEND PICTURE MESSAGE TO A GROUP

- Press the Navigation Key up or down to select the existing group name that you want to change.
- Press Right Soft Key **Options** > **New Picture Message**.

3. Input a "Text", "Picture", "Sound", "Subject", "Name Card", and then press Right Soft Key **Options** to select "Preview", "Save As Draft", "Add Quick Text", "Add Slide", "Priority Level", "Remove Picture", "Remove Sound", "Remove Name Card" or "Cancel Message".

4. To send the Picture Message, press **Send**.

#### TO SEND VOICE MESSAGE TO A GROUP

1. Press the Navigation Key up or down to select the existing group name that you want to change.
2. Press Right Soft Key **Options** > **New Voice Message**.
3. Input a "Voice", "Text", "Subject", "Name Card", and then press Right Soft Key **Options** to select "Review", "Save As Draft", "Add Quick Text", "Priority Level", "Remove Name Card" or "Cancel Message".
4. To send the Voice Message, press **Send**.

#### TO ERASE SAVED GROUP

1. Press the Navigation Key up or down to select the existing group name that you want to erase.
2. Press Right Soft Key **Options** > **Erase**.

3. "ERASE GROUP?" will appear on the screen. > **Yes** > **OK**.

#### SPEED DIALS

(Menu > Contacts > 4)

In idle mode, calls can be placed to numbers stored in speed dial by pressing & holding the location number on the key pad. For a 2-digit location number, press the first number and then press and hold the second number. Speed Dial 1 is assigned to Voice Mail and cannot be changed. Speed Dials 97, 98, and 99 are assigned to Verizon Wireless Account Information.

- **#BAL:** #BAL is a VZW Customer Service VRU number (Free call) that provides customers information on their Verizon Wireless billing balance.
- **#MIN:** #MIN is a VZW Customer Service VRU number (Free call) that provides customers information on their Verizon Wireless usage.
- **#PMT:** #PMT is a VZW Customer Service VRU number (Free call) that allows user to make a bill payment, either with a payment option they have already set up, or using a new, one time payment option.

1. To assign a phone number to a location use the Navigation Key to scroll up and down to select the location. > **Set**.
2. Select the contact by pressing the Navigation Key up or down > **OK**.
3. Select the phone number by pressing the Navigation Key up or down. > **OK**.

 "Unassigned" appears if the location is available.

4. "SET SPEED DIAL TO CONTACT" will appear on the screen. > **Yes** > **OK**. > "SPEED DIAL SET" will be displayed.

#### TO ERASE SAVED SPEED DIAL

1. Press the Navigation Key up or down to select the existing speed dial.
2. Press Right Soft Key **Remove** > **Yes** > **OK**.

#### IN CASE OF EMERGENCY

(Menu > Contacts > 5)

Your phone has a special menu to organize your emergency contacts and personal information.

#### TO ASSIGN EMERGENCY CONTACTS

1. Select one of the entries by pressing the Navigation Key up or down. To set a new emergency number, select **Contact 1**, **Contact 2**, or **Contact 3** > **Add**.
2. If **From Contacts** selected to select from an entry in your contact list or **New Contact** selected to enter a new phone number.
3. Your contact entries appear in alphabetical order. Select the contact you want to add by pressing the Navigation Key up or down > **OK**.

4. Press **OK** to save the In Case of Emergency Contact.

#### TO RE-ASSIGN EMERGENCY CONTACTS

1. Select one of the entries by pressing the Navigation Key up or down, press Right Soft Key **Options** > **Re-assign**.

#### TO ERASE ASSIGNED EMERGENCY CONTACTS

1. Select one of the entries by pressing the Navigation Key up or down, press Right Soft Key **Options** > **Unassign** > **Yes** > **OK**.

#### TO CALL WITH A ASSIGNED EMERGENCY CONTACT

1. Select one of the entries by pressing the Navigation Key up or down, press Left Soft Key **Call** or **SEND Key**.

#### TO ADD PERSONAL INFO

You can use the "Personal Info" field to add personal notes, including allergies, medications, and other health information.

1. Use the Navigation Key to scroll down to **Personal Info**. > **View**.
2. Select the Navigation Key up or down to select **Note 1**, **Note 2**, or **Note 3** > **Add**.



- Use the keypad to enter the text of a note that would prove useful in the case of an emergency. > **Save**.

### TO EDIT SAVED PERSONAL INFO







- Select one of the entries by pressing the Navigation Key up or down, > **View** > **Edit** > **Save**.

### TO ERASE SAVED PERSONAL INFO

- Select one of the entries by pressing the Navigation Key up or down, press Right Soft Key **Erase** > **Yes** > **OK**.

### MY NAME CARD (Menu > Contacts > 6)

Create your own business card, so that you can send all your details upon request by TXT message, by E-mail, by Bluetooth or etc...

- The name card in your phone book is displayed. To enter your information or edit it. > Press Left Soft Key **Edit**.
- Press the Navigation Key up to enter or edit your name. Press the Navigation Key down to enter or edit information in the remaining fields (  Mobile 1,  Home,  Work,  E-mail 1,  Mobile 2,  Fax,  E-mail 2). > **Save**.

### SEND MY NAME CARD

- Press Right Soft Key **Send** > Select **TXT**, **Picture** or **Video Message**.

### MISSED (Menu > Recent Calls > 1)

Displays information about the 90 most recently missed calls. Place a call to a missed call number by simply pressing **SEND Key**.

- To view missed call details, press **Open**.

-  • If the number is already stored in your contacts, only the name appears.
- If the number is not stored, only the phone number appears.
- Call details include date, time and phone number.

- Press **SEND Key** to place a call to a missed number or press Right Soft Key **Options** and then select one of the following options:

- **Save to Contacts:** To store the phone number in your contact list.
- **Details:** If the selected entry is already stored in the contacts list, view the caller's information.
- **Erase:** To erase a missed calls listing.
- **Lock/Unlock:** To lock or unlock a missed calls listing.
- **Erase All:** To erase all missed calls listings.
- **View Timers:** To display usage time.

-  • After 90 missed calls, the oldest call will automatically be erased from the history.
- Press Left Soft Key **Message**, to send a TXT, Picture or Voice Message.

### RECEIVED (Menu > Recent Calls > 2)

Displays information about the 90 most recently received calls. Place a call to a received call by simply pressing **SEND Key**.

- To view received call details, press **Open**.

-  • If the number is already stored in your contacts, only the name appears.
- If the number is not stored, only the phone number appears.
- Call details include date, time and phone number.

- Press **SEND Key** to place a call to a missed number or press Right Soft Key **Options** and then select one of the following options:

- **Save to Contacts:** To store the phone number in your phone book.
- **Details:** If the selected entry is already stored in the contacts list, view the caller's information.
- **Erase:** To erase a received calls listing.
- **Lock/Unlock:** To lock or unlock received calls listing.
- **Erase All:** To erase all received calls listings.
- **View Timers:** To display usage time.

-  • After 90 received calls, the oldest call will automatically be erased from the history.
- Press Left Soft Key **Message**, to send a TXT, Picture or Voice Message.

## DIALED

(Menu > Recent Calls > 3)

Displays information about the 90 most recently dialed numbers. Place a call to a dialed call by simply pressing **SEND Key**.

### 1. To view dialed call details, press **Open**.

-  If the number is already stored in your contacts, only the name appears.
- If the number is not stored, only the phone number appears.
- Call details include date, time and phone number.

### 2. Press **SEND Key** to place a call to a missed number or press Right Soft Key **Options** and then select one of the following options:

- **Save to Contacts:** To store the phone number in your contact list.
- **Details:** If the selected entry is already stored in the contacts list, view the caller's information.
- **Erase:** To erase a dialed calls listing.
- **Lock/Unlock:** To lock or unlock a dialed calls listing.
- **Erase All:** To erase all dialed calls listings.
- **View Timers:** To display usage time.

-  After 90 dialed calls, the oldest call will automatically be erased from the history.
- Press Left Soft Key **Message**, to send a TXT, Picture or Voice Message.

## ALL

(Menu > Recent Calls > 4)

Displays information about the most recently received, dialed and missed calls.

### 1. To view details, press **Open**.

-  If the number is already stored in your contacts, only the name appears.
- If the number is not stored, only the phone number appears.
- Call details include date, time and phone number.

### 2. Press **SEND Key** to place a call to call logs or press Right Soft Key **Options** and then select one of the following options:

- **Save to Contacts:** To store the phone number in your phone book.
- **Details:** If the selected entry is already stored in the contacts list, view the caller's information.
- **Erase:** To erase a all calls listing.
- **Lock/Unlock:** To lock or unlock all calls listing.
- **Erase All:** To erase all calls listings.
- **View Timers:** To display usage time.

-  After the 270 received, dialed or missed calls, the oldest call will automatically be erased from the history.
- Press Left Soft Key **Message**, to send a TXT, Picture or Voice Message.

## BLOCKED

(Menu > Recent Calls)

This menu appears only when "Incoming Call Restriction" is set.

### 1. To view received call details, press **Open**.

-  If the number is already stored in your contacts, only the name appears.
- If the number is not stored, only the phone number appears.
- Call details include date, time and phone number.

### 2. Press **SEND Key** to place a call to a missed number or press Right Soft Key **Options** and then select one of the following options:

- **Save to Contacts:** To store the phone number in your phone book.
- **Details:** If the selected entry is already stored in the contacts list, view the caller's information.
- **Erase:** To erase a blocked calls listing.
- **Lock/Unlock:** To lock or unlock blocked calls listing.
- **Erase All:** To erase all blocked calls listings.
- **View Timers:** To display usage time.

-  After 90 blocked calls, the oldest call will automatically be erased from the history.
- Press Left Soft Key **Message**, to send a TXT, Picture or Voice Message.
- Please refer to [page 43](#) for more details on "Restrictions".

## VIEW TIMERS

(Menu > Recent Calls > 5)

Checks the usage time and manages your calls within the limit you set.

The 11 timers include (Last Call, All Calls, Received Calls, Dialed Calls, Roaming Calls, Transmit Data, Received Data, Total Data, Last Reset, Lifetime Calls, Lifetime Data Counter):

### 1. Select "Last Call", "All Calls", "Received Calls", "Dialed Calls", "Roaming Calls", "Transmit Data", "Received Data", "Total Data".

To reset an individual, press Left Soft Key **Reset**, select "Yes," then press **OK**.

To reset all timers, press Right Soft Key **Reset All**, then select "Yes," press **OK**.

### 2. Select "Last Reset", "Lifetime Calls", "Lifetime Data Counter".

To reset all timers, press Right Soft Key **Reset All**, then select "Yes," press **OK**.

### 3. To return to the previous page, press **OK**.

## BLUETOOTH

(Menu > Settings & Tools > 3)

Bluetooth technology connectivity enables wireless connections between electronic devices. If connected with a Bluetooth Handsfree device, you can use your phone more freely. With DUN, you can also use the phone as a wireless modem. It can also be used to connect wirelessly to products that use Bluetooth wireless technology, such as computers. You can synchronize your phone and your PC using Bluetooth connectivity. Since devices with Bluetooth connectivity communicate using radio waves, your phone and the other device do not need to be in direct line-of-sight. The two devices only need to be within 10 meters (30 feet) of each other. The connection can be subject to interference from obstructions such as walls or other electronic devices. This device is compliant with Bluetooth specification 1.1, supporting the following profiles: HSP V1.1 (headset profile), HFP V1.0 (handsfree car kit profile), DUN V1.1 (dial-up networking), GAP (general access profile) and SPP V1.1 (serial port profile). To ensure interoperability between other devices supporting Bluetooth technology, use UTStarcom approved enhancements for this model. Check with the manufacturers of other devices to determine their compatibility with this phone. There may be restrictions on using Bluetooth technology in some locations. Check with your local authorities or Verizon. If you want more information on this function, visit the Bluetooth Technology organization Web site: <https://www.bluetooth.org/>.



**Important:** Features using Bluetooth technology, or allowing such features to run in the background while using other features, increase the demand on battery power and reduce the battery life.

### BLUETOOTH ON/OFF

The Power feature allows you to turn the Bluetooth function on and off.

1. Press Left Soft Key **Turn On/Turn Off** to activate/deactivate Bluetooth mode.

### ADD NEW DEVICE

Pairing is the process that allows the handset to locate, establish and register 1-to-1 connection with the target device.

1. Select "Add New Device", then press **OK**. If Bluetooth is turned off, "TURN BLUETOOTH POWER ON?" will appear. Select "Yes" and press **OK**.
2. By pressing Right Soft Key **Options**, you can choose from the following:
  - **My Phone Name:** Your phone's Bluetooth name will appear to other in-range Bluetooth devices, depending on your discovery mode. Enter a new name and press **OK** to save and exit.
  - **Discovery Mode:** Turns Discovery Mode "on" or "off." If Discovery Mode is turned on, other devices will be able to find your device for one minute.

• **Supported Profiles:** Displays the following list of options.

1. **Headset:** Supports use of a compatible Bluetooth headset for mono voice.
  2. **Handsfree:** Supports Bluetooth headsets, and may also support other installed compatible Bluetooth devices with speaker phone capabilities, such as car kits or a conference room device.
  3. **Stereo:** Supports use of a compatible Bluetooth headset for stereo voice.
3. Instructions "PLACE DEVICE YOU ARE CONNECTING TO IN DISCOVERABLE MODE" will be displayed. Highlight the device and press **OK**.
  4. The handset will prompt you for the passkey. Consult the Bluetooth accessory instructions for the appropriate passkey (typically "0000" - 4 zeroes). Enter the passkey and press **OK**.
 

 The default PIN code may differ depending on Bluetooth devices. Please refer to the user guide of the Bluetooth device that you wish to use.
  5. Once pairing is successful, select "Yes" and press **OK** to connect with the device.
  6. Once paired, you will see the device listed in the "Add New Device" menu. By pressing Right Soft Key **Options**, you can choose from the following:
    - **Remove Device:** Removing a device from the paired list.
    - **Rename Device:** Renaming the paired device.

• **Incoming Security:** To Select "Always Ask" or "Always Connect".

• **Device Info:** Reviewing information about the paired device.

## SOUNDS SETTINGS

(Menu > Settings & Tools > 4)

### CALL SOUNDS

(Menu > Settings & Tools > 4 > 1)

To select a ringer type for incoming calls:

#### CALL RINGTONE

(Menu > Settings & Tools > 4 > 1 > 1)

1. Select one of the available ring types > **OK**.
  - **Up or Down Navigation Key:** "Get New Ringtones" or select your desired ringer type.
  - To play/stop sound, press Left Soft Key **Play/Stop**.

#### CALL VIBRATE

(Menu > Settings & Tools > 4 > 1 > 2)

1. Select "On" or "Off" with the Navigation Key up or down. > **OK**.

### ALERT SOUNDS

(Menu > Settings & Tools > 4 > 2)

When selected, this setting alerts you to the following handset changes:

#### TXT MESSAGE

(Menu > Settings & Tools > 4 > 2 > 1)

1. Select "Tone", "Vibrate" or "Reminder" with the Navigation Key up or down and then select one of the following options by pressing

the Navigation Key up or down > **OK**.

- **Tone:** Get New Ringtones or select your desired ringer type by pressing the Navigation Key up or down. > **OK**.
- **Vibrate:** Select "On" or "Off" by pressing the Navigation Key up or down. > **OK**.
- **Reminder:** Select "Once", "Every 2 Minutes", "Every 15 Minutes" or "Off". > **OK**.

#### PIC-VOICE MESSAGE (Menu > Settings & Tools > 4 > 2 > 2)

1. Select "Tone", "Vibrate" or "Reminder" with the Navigation Key up or down and then select one of the following options by pressing the Navigation Key up or down. > **OK**.

- **Tone:** Get New Ringtones or select your desired ringer type by pressing the Navigation Key up or down. > **OK**.
- **Vibrate:** Select "On" or "Off" by pressing the Navigation Key up or down. > **OK**.
- **Reminder:** Select "Once", "Every 2 Minutes", "Every 15 Minutes" or "Off". > **OK**.

#### VOICEMAIL (Menu > Settings & Tools > 4 > 2 > 3)

1. Select "Tone", "Vibrate" or "Reminder" with the Navigation Key up or down and then select one of the following options by pressing the Navigation Key up or down. > **OK**.

- **Tone:** Get New Ringtones or select your desired ringer type by pressing the Navigation Key up or down. > **OK**.
- **Vibrate:** Select "On" or "Off" by pressing the Navigation Key up or down. > **OK**.
- **Reminder:** Select "Once", "Every 2 Minutes", "Every 15 Minutes" or "Off". > **OK**.

#### EMERGENCY TONE (Menu > Settings & Tools > 4 > 2 > 4)

1. Select "Alert", "Vibrate" or "Off" with the Navigation Key up or down. > **OK**.

#### KEYPAD VOLUME (Menu > Settings & Tools > 4 > 3)

To adjust key pad tone:

1. Select "Off" or "Level 1(Low) ~ Level 5 (High)" with the Navigation Key up or down. > **OK**.

#### SERVICE ALERTS (Menu > Settings & Tools > 4 > 4)

##### ERI (Enhanced Roaming Indicator) (Menu > Settings & Tools > 4 > 4 > 1)

The Enhanced Roaming Indicator (ERI) feature displays a text banner on the display screen informing the handset user of which systems the wireless device is using as compared to the service plan they purchased. The ERI Banner text changes to tell a customer if they are using the: "Verizon Network", "Extended Network" or "Roaming".

1. Select "On" or "Off" with the Navigation Key up or down. > **OK**.

##### MINUTE BEEP (Menu > Settings & Tools > 4 > 4 > 2)

Sounds an alert every minute during a call.

1. Select "On" or "Off" with the Navigation Key up or down. > **OK**.

#### CALL CONNECT (Menu > Settings & Tools > 4 > 4 > 3)

Notifies you that a call has been successfully placed.

1. Select "On" or "Off" with the Navigation Key up or down. > **OK**.

#### DEVICE CONNECT (Menu > Settings & Tools > 4 > 5)

Allows you to turn the Device Connect On or Off:

1. Select "On" or "Off" with the Navigation Key up or down. > **OK**.

#### POWER ON/OFF (Menu > Settings & Tools > 4 > 6)

##### POWER ON (Menu > Settings & Tools > 4 > 6 > 1)

Allows you to activate/deactivate the power on tones.

1. Select "On" or "Off" with the Navigation Key up or down. > **OK**.

##### POWER OFF (Menu > Settings & Tools > 4 > 6 > 2)

Allows you to activate/deactivate the power off tones.

1. Select "On" or "Off" with the Navigation Key up or down. > **OK**.

#### DISPLAY SETTINGS (Menu > Settings & Tools > 5)

Allows you to customize the display.

#### BANNER (Menu > Settings & Tools > 5 > 1)

You can choose to display a personal Banner greeting or the Enhanced Roaming Indicator (ERI) banner on the phone's screens:

##### PERSONAL BANNER (Menu > Settings & Tools > 5 > 1 > 1)

The text greeting can be up to 16 characters and is displayed on your phone's screen in standby mode.

1. Enter a new personal greeting. > **OK**.  
To change the input mode, press Left Soft Key **Abc**.

##### ERI BANNER (Menu > Settings & Tools > 5 > 1 > 2)

1. Select "On" or "Off" with the Navigation Key up or down. > **OK**.

#### BACKLIGHT (Menu > Settings & Tools > 5 > 2)

Backlights the display and key pad and activates dimming for easy viewing in dark places.

**DISPLAY** (Menu > Settings & Tools > 5 > 2 > 1)

1. Select one of the following options by pressing the Navigation Key up or down: > **OK**.
  - 7 Seconds / • 15 Seconds / • 30 Seconds / • Always On / • Always Off

**KEYPAD** (Menu > Settings & Tools > 5 > 2 > 2)

1. Select one of the following options by pressing the Navigation Key up or down: > **OK**.
  - 7 Seconds / • 15 Seconds / • 30 Seconds / • Always On / • Always Off

**WALLPAPER** (Menu > Settings & Tools > 5 > 3)

1. Select Default to choose a pre-installed display, Downloads or Pic # to choose a display you have downloaded to your phone. > **OK**.
2. To launch "Get It Now", press Right Soft Key **Get New**.
3. To expand selected image, press Left Soft Key **View**.

**DISPLAY THEMES** (Menu > Settings & Tools > 5 > 4)

Selecting a Display theme Will change the color and font of your screen.

1. Select "Urban" or "Cool Gray" with the Navigation Key up or down.

> **SET**.

2. To preview selected theme, press Left Soft Key **Preview**.

**MAIN MENU** (Menu > Settings & Tools > 5 > 5)

To select a display menu style:

1. Select "Tab", "List" or "Grid" with the Navigation Key up or down. > **OK**.
2. To preview selected menu style, press Left Soft Key **Preview**.

**DIAL FONTS** (Menu > Settings & Tools > 5 > 6)

To select a display dial fonts size:

1. Select "Normal" or "Large Only" with the Navigation Key up or down. > **OK**.

**CLOCK FORMAT** (Menu > Settings & Tools > 5 > 7)

To select a display clock style:

1. Select one of the following options by pressing the Navigation Key up or down: > **OK**.
  - Analog / • Large Analog / • Digital 12 / • Large Digital 12 / • Digital 24 / • Large Digital 24 / • Off

**PHONE SETTINGS** (Menu > Settings & Tools > 6)**STANDALONE MODE** (Menu > Settings & Tools > 6 > 1)

Standalone Mode allows you to turn off the phone's radio functions where they are restricted.

1. Select "On" or "Off" with the Navigation Key up or down. > **OK**.



In Standalone Mode, all menu functions can be accessed except making calls, receiving calls, data connection (Wap, Brew) and Bluetooth.

**SET SHORTCUTS** (Menu > Settings & Tools > 6 > 2)

Your phone offers you the option of assigning a shortcut key (Navigation Key) to a favorite or often-used function. To assign a shortcut to the key:

**SET MY SHORTCUTS** (Menu > Settings & Tools > 6 > 2 > 1)

1. Select "Shortcut 1", "Shortcut 2", "Shortcut 3" or "Shortcut 4" with the Navigation Key up or down: > **SET**.
2. Select one of the following options by pressing the Navigation Key up or down: > **OK**.
  - Alarm Clock / • Bluetooth Menu / • Bluetooth on/off / • Calculator / • Calendar / • Call Settings / • Chat / • Display Settings / • Mobile Web Mail / • Extras / • Games / • Media Center / • Get New Extra /

- Get New Game / • Get New Pictures / • Get New Ringtones / • Get New Browser & Download / • Messaging Inbox / • Mobile IM / • Music & Tones / • My Account / • My Music / • My Pictures / • My Ringtones / • My Sounds / • New Contact / • New TXT Message / • New Picture Message / • Mobile Web / • Phone Settings / • Pictures / • PIX Place / • Settings & Tools / • Sounds Settings / • Sync Music / • Tools / • Browse & Download

3. To reset selected location shortcut setting, pressing Right Soft Key **Options** > **Reset Shortcut #** > **Yes** > **OK**.
4. To reset all location shortcuts setting, pressing Right Soft Key **Options** > **Reset My Shortcuts** > **Yes** > **OK**.

**SET DIRECTIONAL KEYS** (Menu > Settings & Tools > 6 > 2 > 2)

1. Select "UP Directional Key", "LEFT Directional Key" or "DOWN Directional Key" with the Navigation Key up or down: > **SET**.
2. Select one of the following options by pressing the Navigation Key up or down: > **OK**.
  - Alarm Clock / • Bluetooth Menu / • Bluetooth on/off / • Calculator / • Calendar / • Call Settings / • Chat / • Display Settings / • Mobile Web Mail / • Extras / • Games / • Media Center / • Get New Extra / • Get New Game / • Get New Pictures / • Get New Ringtones / • Get New Browser & Download / • Messaging Inbox / • Mobile IM / • Music & Tones / • My Account / • My Music / • My Pictures / • My Ringtones / • My Sounds / • New Contact / • New TXT Message / • New Picture Message /

- Mobile Web / • Phone Settings / • Pictures / • PIX Place / • Settings & Tools / • Sounds Settings / • Sync Music / • Tools / • Browse & Download

- To reset selected location directional key setting, pressing Right Soft Key **Options** > **Reset [Location] Key** > **Yes** > **OK**.
- To reset all location directional keys setting, pressing Right Soft Key **Options** > **Reset Directional Keys** > **Yes** > **OK**.

## VOICE COMMANDS (Menu > Settings & Tools > 6 > 3)

You can use voice commands to control your device.

### MODE (Menu > Settings & Tools > 6 > 3 > 1)

- Select **"Prompts"**, **"Readout"** or **"Tones Only"** with the Navigation Key up or down: > **OK**.
  - **Prompts:** Reads out only the command prompts, outgoing caller ID (contact name and type or number), and confirming message recipient (contact name and type or number) when using the Send command.
  - **Readout:** Reads out prompts, menus, outgoing caller ID (contact name and type or number), status information, and confirming message recipient (contact name and type or number) when using the Send command.
  - **Tones Only:** Will only prompt the user with a tone (in place of the Readout prompt).

 If you change the setting details in the phone's mode in Voice Commands, it will affect the mode in Sound (refer to page 51) or vice versa.

## CALL ALERT (Menu > Settings & Tools > 6 > 3 > 2)

- Select **"Ring Only"**, **"Caller ID + Ring"** or **"Name Repeat"** with the Navigation Key up or down: > **OK**.

- **Ring Only:** Deactivate Voice Call Alert. You can hear ringtone only.
- **Caller ID + Ring:** Playback the Voice Call Alert once and then you will hear ringtone.
- **Name Repeat:** Activate Voice Call Alert. You will hear the caller's details repeatedly.

 For more information about the enhanced voice commands supported by your device, see **"Voice Tools"**. Please refer to page 48 for more details.

## LANGUAGE (Menu > Settings & Tools > 6 > 4)

Selects the language in which letters are displayed on the screen.

- Select **"English"** or **"Español"** with the Navigation Key up or down: > **OK**.

## LOCATION (Menu > Settings & Tools > 6 > 5)

To determine whether or not the network system can detect your position:

- Select **"Location On"** or **"E911 Only"** with the Navigation Key up or down: > **OK**.
  - **Location On:** Your location is now available to the network.
  - **E911 Only:** Your location will be hidden from network & application except 911.

## SECURITY (Menu > Settings & Tools > 6 > 6 > Password)

Prevents unauthorized use of your phone. The following settings can be restricted:

- Enter your lock code. > **OK**.

 After three consecutive incorrect Lock Code entries, **"INCORRECT CODE. PLEASE RE-ENTER CODE"** appears, and the Lock Code is blocked. If you forget any of these codes, contact your service provider.

### EDIT CODES (Menu > Settings & Tools > 6 > 6 > Password > 1)

Changes your Device/Location 4-digit lock code.

#### Phone Only (Menu > Settings & Tools > 6 > 6 > Password > 1 > 1)

Changes your phone's 4-digit lock code.

- Enter a **"New Code"**, and re-enter a **"New Code"** > **OK**.

#### Calls & Services (Menu > Settings & Tools > 6 > 6 > Password > 1 > 2)

Changes your Calls & Service's 4-digit lock code.

- Enter a **"Current Code"**, and enter a **"New Code"**, and then re-enter a **"New Code"** > **OK**.

## RESTRICTIONS (Menu > Settings & Tools > 6 > 6 > Password > 2)

You can restrict the use of your phone for outgoing calls, incoming calls, outgoing messages, incoming messages and dial-up modem.

- Enter your current lock code. > **OK**.

### Location Setting (Menu > Settings & Tools > 6 > 6 > Password > 2 > 1)

- Select **"Unlock Setting"** or **"Lock Setting"** with the Navigation Key up or down. > **OK**.

### Calls (Menu > Settings & Tools > 6 > 6 > Password > 2 > 2)

- Select **"Incoming Calls"** or **"Outgoing Calls"** with the Navigation Key up or down. > **OK**.
- Select **"Allow All"**, **"Contacts Only"** or **"Block All"** with the Navigation Key up or down. > **OK**.

### Messages (Menu > Settings & Tools > 6 > 6 > Password > 2 > 3)

- Select **"Incoming Messages"** or **"Outgoing Messages"** with the Navigation Key up or down. > **OK**.
- Select **"Allow All"** or **"Block All"** with the Navigation Key up or down. > **OK**.

**PHONE LOCK SETTING** (Menu > Settings & Tools > 6 > 6 > Password > 3)

Prevents the phone from being used without entering the lock code first.

1. Select “**Unlocked**” or “**On Power Up**” with the Navigation Key up or down: > **OK**.

- **Unlocked:** Do not lock the phone.
- **On Power Up:** Not locked, but it is automatically locked when power is recycled.

**LOCK PHONE NOW** (Menu > Settings & Tools > 6 > 6 > Password > 4)

Lock the phone now.

1. The phone is now locked.
2. To unlock phone, press Left Soft Key **Unlock**. > Enter your Current Code > **OK**.

**RESTORE PHONE** (Menu > Settings & Tools > 6 > 6 > Password > 5)

To reset your phone.

1. Read the message. (PERMANENTLY ERASE ALL USER DATA & RESET SETTINGS TO FACTORY DEFAULTS?)
2. Select **Yes** > **OK**.

**SYSTEM SELECT** (Menu > Settings & Tools > 6 > 7)

Selects the Preferred System.

1. Select “Automatic B”, “Automatic A” or “Home Only” with the Navigation Key up or down. > **OK**.

**NAM SELECTION** (Menu > Settings & Tools > 6 > 8)

Enables Auto NAM (Number Assignment Modules) or manually selects a NAM.

**AUTO NAM** (Menu > Settings & Tools > 6 > 8 > 1)

Automatically switches phone to proper NAM when you have multiple NAM registrations.

1. Select “**On**” or “**Off**” with the Navigation Key up or down: > **OK**.

**CHANGE NAM** (Menu > Settings & Tools > 6 > 8 > 2)

1. Select “**NAM1-VERIZON**” or “**NAM2-VERIZON**” with the Navigation Key up or down: > **OK**.

**CALL SETTINGS** (Menu > Settings & Tools > 7)**ANSWER OPTIONS** (Menu > Settings & Tools > 7 > 1)

To select an answer mode:

1. Select one of the following options by pressing the Navigation Key up or down, then press **Mark/Unmark**. > Press Left Soft Key **Done**.

- **Slide Open** / • **Any Key** / • **Send Only** / • **Auto w / Hands-free**



- If “**Auto w / Hands-free**” is selected, the Automatic Answer feature is disabled when you close the phone.
- The four functions can be used at the same time.

**AUTO RETRY** (Menu > Settings & Tools > 7 > 2)

Automatically redials after a set time interval.

1. Select one of the following options by pressing the Navigation Key up or down: > **OK**.

- **10 Seconds** / • **30 Seconds** / • **60 Seconds** / • **Off**

**TTY MODE** (Menu > Settings & Tools > 7 > 3)

Your phone is able to operate with a TTY (Teletypewriter) device in both analog and digital modes. This feature is system dependent and may not be available in all areas.

1. Select one of the following options by pressing the Navigation Key up or down: > **OK**.

- **TTY Full** / • **TTY + Talk** / • **TTY + Hear** / • **TTY Off**

**ONE TOUCH DIAL** (Menu > Settings & Tools > 7 > 4)

1. Select “**On**” or “**Off**” with the Navigation Key up or down: > **OK**.

**VOICE PRIVACY** (Menu > Settings & Tools > 7 > 5)

Enhances voice privacy and avoids tapping during a call.

1. Select “**On**” or “**Off**” with the Navigation Key up or down: > **OK**.

- **On:** Makes it more difficult to wire tap.

**DTMF TONES** (Menu > Settings & Tools > 7 > 6)

To adjust tone length:

1. Select “**Normal**” or “**Long**” with the Navigation Key up or down: > **OK**.

## MEMORY

(Menu > Settings & Tools > 8)

### SAVE OPTIONS

(Menu > Settings & Tools > 8 > 1)

You can save various data including Picture, Video and Sound files on either the phone's memory or memory card.

1. Select "1. Pictures" or "2. Sounds" with the Navigation Key up or down: > OK.
2. Select "Phone Memory" or "Card Memory" with the Navigation Key up or down: > OK.

### PHONE MEMORY

(Menu > Settings & Tools > 8 > 2)

1. Select one of the following options by pressing the Navigation Key up or down: > OK.
  - Phone Memory Usage / • My Pictures / • My Music / • My Sounds
2. The current memory information appears on the display screen. To return to the previous page. > OK.

## CARD MEMORY

(Menu > Settings & Tools > 8 > 3)

1. Select one of the following options by pressing the Navigation Key up or down: > OK.
  - Card Memory Usage / • My Pictures / • My Music / • My Sounds
2. The current memory information appears on the display screen. To return to the previous page. > OK.

## PHONE INFO

(Menu > Settings & Tools > 9)

### MY NUMBER

(Menu > Settings & Tools > 9 > 1)

Displays your phone number.

1. You will see the MDN/MIN and provider name.
2. To return to the previous page. > OK.

### SW / HW VERSION

(Menu > Settings & Tools > 9 > 2)

Displays the Software Version/PRL Version/ERI Version/Browser Version/Media Center Version/MSUI Version/HW Version/MEID.

1. The software, hardware, browser and other's versions appear.
2. To return to the previous page. > OK.

## ICON GLOSSARY

(Menu > Settings & Tools > 9 > 3)

Displays the Indicator Icons of your cellular telephone.

1. To view an explanation of icons that appear on the display by pressing the Navigation Key up or down.
2. To return to the previous page. > OK.

## SOFTWARE UPDATE

(Menu > Settings & Tools > 9 > 4)

The update phone firmware (software) option allows you to download and update the software in your phone automatically. Only the internal software is updated; no Contacts entries or other information saved to your phone will be deleted.

1. Select "1. Status" > OK.
2. You will see the software status.



## VOICE COMMANDS

(Menu > Settings & Tools > 2 > 1)

Your phone is equipped with an AVR (Advanced Voice Recognition) feature. This feature allows you to make calls or use the phone's functions by simply using your voice. All you have to do is talk into the phone, and the phone will recognize your voice and complete tasks by itself.

1. The phone displays the Command menu and prompts you to say the name of the command you want to use. To complete your task, simply follow the voice prompts. You can speak the name of the command after you hear a beep.

 You can hear a beep in the Tone Only Mode (Settings & Tools > Phone Settings > Voice Commands > Mode > Tones Only Mode) while you can see a prompt without a beep sound in the Prompt Mode or Readout Mode.

2. Select one of the following options by pressing the Navigation Key up or down. > OK.
  - Call <Name or #> / • Send <MSG Type> / • Go To <Shortcut> /
  - Check <Item> / • Contact <Name> / • Play <Playlist> / • My Account / • Help
3. When it recognizes one of these commands, the phone launches the associated application. If the phone does not hear a command within approximately eight seconds, AVR mode will turn itself off.

## CALL <NAME OR #>

Use the Call command to voice dial a name from your contact list or a phone number. When dialing a number, pronounce each digit, but do not pause noticeably between the digits.

1. You will hear "Please say a command" and the Voice Commands menu will be displayed.
2. If calling a contact from your list, say Call <Name>. Your phone will ask you to confirm the name you said. Say Yes if it was repeated correctly. That phone number will be dialed. If there is more than one number saved for that contact, you will be asked to confirm which number to dial.

Examples: - Call Tom Smith, - Call 617 555-1212, - Call Bob Carson's mobile, - Call Dee Harper at Home.

## SEND <MSG TYPE>

Use the Send command to send a text or other type of message to a specified name or number.

1. You will hear "Please say a command" and the Voice Commands menu will be displayed.

2. Say "Send" followed immediately by one of the following items:

• Text / • Picture

Examples: - Send Picture to Dee Harper's Mobile,  
- Send Text Tom Smith.

## GO TO <SHORTCUT>

Use the Go To command to open an application on your phone. You can say "Go To" by itself and be prompted to say the application name, or you can skip the prompt by saying "Go To" followed by the application name.

1. You will hear "Please say a command" and the Voice Commands menu will be displayed.
2. Say "Go To" followed immediately by one of the following items:
  - Contacts / • Recent Calls / • Messaging / • Media Center / • Settings & Tools /
  - Mobile Web / • My Music

## CHECK <ITEM>

The Check command lets you check status information for your phone. You can say "Check" or "Check Status" to see and hear all status information.

1. You will hear "Please say a command" and the Voice Commands menu will be displayed.

2. Say "Check" followed immediately by one of the following items:

• Status / • Voicemail / • Messages / • Missed Calls / • Time /  
• Signal Strength / • Battery / • Volume

## CONTACTS <NAME>

Use the Lookup command to retrieve and display information for any name stored in your contact list.

1. You will hear "Please say a command" and the Voice Commands menu will be displayed.
2. Say "Lookup <Name>".  
Examples: - Lookup Tom Jones.
3. The View Contact page will be displayed for that contact name.

## PLAY <PLAYLIST>

Use the Play command to playback one of the playlists. Say "PLAY" followed by a playlist and your phone will playback the recognized playlist for you.

1. You will hear "Please say a command" and the Voice Commands menu will be displayed.

- Say "Play <Playlist>".  
Say "Play All Songs" (to playback all songs saved in your phone.)

## MY ACCOUNT

- You will hear "Please say a command" and the Voice Commands menu will be displayed.
- Say "My Account".
- Your phone will make a web connection.

## HELP

- You will hear "Please say a command" and the Voice Commands menu will be displayed.
- Say "Help".
- The Help guide will be displayed on your phone.

## VOICE COMMANDS SETTINGS

### DIGIT DIAL READOUT

The Digit Dial Readout setting controls if digits are read out when you type in a phone number with the keypad.

- Press Right Soft Key **Settings** > **1. Digit Dial Readout** > Select "On" or "Off" with the Navigation Key up or down > **OK**.

### CONFIRMATION

When voice recognition is not confident it has recognized a name or number correctly, it will show you a list of up to three choices. You can control when choice lists appear.

- Press Right Soft Key **Settings** > **2. Confirmation** > Select "Automatic", "Always Confirm" or "Never Confirm" with the Navigation Key up or down > **OK**.

### SENSITIVITY

The Sensitivity setting controls how the voice recognition software determines when a spoken word is a match. If you frequently experience the messages "Please Repeat..." or "No Match Found," adjust the sensitivity toward Reject Less. If you frequently experience false activations (when the phone recognizes a name you didn't say), adjust the sensitivity toward Most Sensitive.

- Press Right Soft Key **Settings** > **3. Sensitivity** > Select "Most Sensitive", "Recommended" or "Least Sensitive" with the Navigation Key up or down > **OK**.

### ADAPTATION

Digit Dialing is speaker independent, which means that no training or adaptation is required. Some users with heavy accents or unusual voice characteristics may find difficulty in achieving high accuracy with speaker independent Digit Dialing, so the Adapt Digits feature allows users to dramatically improve the digit accuracy through adaptation. Users who get acceptable digit recognition accuracy will find no additional benefit to performing the Adapt Digit adaptation.

- Press Right Soft Key **Settings** > **4. Adaptation**.
- Wait for the beep, and then repeat the digits using a normal tone of voice. (The phone plays back your recording and asks you if the recording sounds "OK.")
- If the recording sounds **OK** (no mistakes and no background noises), say **Yes**. If you need to re-record the digits to fix any problems, say **No**. (The phone then prompts you to say the digits again.)
- Wait for the beep, and then record the digits again. (Repeat this step until you are satisfied with the recording.)
- After confirming that the recording sounds **OK**, repeat the recording process with the next set of digits. (After six sets of digits, the phone will ask you whether you want to do more

adaptation. Answer **Yes**.)

- Repeat steps 1-5 for another nine sets of digits. (After the ninth set of digits, you will be half-way through the session and the phone will ask "More Adaptation?")
- Select **OK** to continue for six more sets of digits, or press **END** Key for partial adaptation. When you are finished with a full session, you will reach a screen that reads, "Adaptation Complete."

### PROMPTS

Allows you to select the voice command system characteristics.

- Press Right Soft Key **Settings** > **5. Prompts** > Select "1. Mode" or "2. Audio playback" with the Navigation Key up or down > **OK**.
  - Mode:** Select the voice command system mode from the following:
    - Prompts:** For handset to read out voice command prompts.
    - Readout:** For handset to read out prompts, dialing digits, menus, and TXT messages.
    - Tones Only:** For handset to prompt you with a tone only.
  - Audio playback:** Allows audio playback to play through the speakerphone or through the earpiece.

## CALL ALERT

Provides audible readout of the phone number and/or name (if in your contact list) of an incoming call.

1. Press Right Soft Key **Settings** > **6. Call Alert** > Select “Ring Only”, “Caller ID + Ring” or “Name Repeat” with the Navigation Key up or down > **OK**.

## ABOUT

1. Press Right Soft Key **Settings** > **7. About**.
2. The VoiceSignal version appears.
3. To return to the previous page. > **OK**.

## CALCULATOR

(Menu > Settings & Tools > 2 > 2)

To access the calculator:

1. Follow the instructions below to calculate  $8 \times 6 \div 4 - 2.5 = 9.50$ 
  - Input 8 and then press the Navigation Key right.
  - Input 6 and then press the Navigation Key Left.
  - Input 4 and then press the Navigation Key down.
  - Input 2 and then press the to input (.).
  - Press 5.
  - Then press **OK** and you will see the answer (9.50).

2. To reset, press Left Soft Key **Clear**.



- Navigation Key right : X, Navigation Key down : -, Navigation Key left : ÷, Navigation Key up : +, \* Key: ., Left Soft Key : Clear, OK Key: =.
- To change the displayed number from positive (+) to negative (-) and vice versa, press # Key.
- Press Right Soft Key **Operator** to use parenthesis and “Exponent”.

## CALENDAR

(Menu > Settings & Tools > 2 > 3)

Sets an event and reminds you of that event.

### ADD NEW EVENT

1. Press the Navigation Key up, down, left or right to choose a date in the calendar. Press Left Soft Key **Add** to enter a new event.



Press Right Soft Key Options to manage your calendar. Press 1. Weekly View, 2. Go To Date, 3. Erase, 4. Erase Passed and 5. Erase All.

2. The Appointment field is highlighted. Enter the name of the event. Press the Navigation Key down to set the other fields for the event:

### APPOINTMENT

Use the keypad to enter an appointment in your schedule.

### START TIME

Use the keypad to set a start time and press Left Soft Key **am/pm**.

### END TIME

Use the keypad to set an end time and press Left Soft Key **am/pm**.

### START DATE

Use the keypad to change or enter the start date.

### RECURRENCE

Press the Navigation Key left or right to set the recurrence of the event (**Daily**, **Weekly**, **Monthly**, **Yearly**). For each recurrence setting, press the Navigation Key down to set the **By Count**. For **Daily**, set the number of days. For **Weekly**, you can press the Navigation Key left or right to select **By Count** or **By Day**. Then press the Navigation Key

down again to make the setting – for **By Count**, enter the number of weeks, for **By Day**, press the Navigation Key left or right to select a day of the week. For **Monthly**, set **By Count** the number of months, or press the Navigation Key right to set **By Day/Month**. For **Yearly**, set **By Day/Month**.

#### END DATE

Use the keypad to change or enter the end date.

#### TIME ZONES

If the Time Zone needs to be adjusted, press Left Soft Key **Set**. Press the Navigation Key up or down to section a new time zone. > **OK**.

• Off /• EST /• EDT /• CST /• CDT /• MST /• MDT /• PST /• PDT /• AKST /  
• AKDT /• HAST /• HADT /• GMT/UTC

#### ALERT

Press Left Soft Key **Set** to select a new ringtone. Press the Navigation Key up or down to highlight a ringtone. > **OK**.

#### VIBRATE

Press the Navigation Key left or right to set **On/Off**.

#### REMINDER

Press the Navigation Key left or right to select an alert time interval option.

• 0 Minute /• 5 Minutes /• 10 Minutes /• 15 Minutes

3. Press **Save** to save it. The date of the event will be marked on your calendar.

#### VIEW PLAN LIST

1. Press the Navigation Key up, down, left or right to choose an event, then press **View**.

#### ERASE SAVED EVENT

1. Select existing event. > Press Right Soft Key **Options** > **3. Erase** > **Yes** > **OK**.

#### ERASE ALL PASSED EVENT

1. Press Right Soft Key **Options** > **4. Erase Passed** > **Yes** > **OK**.

#### ALARM CLOCK

(Menu > Settings & Tools > 2 > 4)

1. Select one of the entries by pressing the Navigation Key up or down. To set a new alarm, choose **Alarm 1**, **Alarm 2** or **Alarm 3**. To edit an existing alarm, select that alarm > **OK**.
2. The setting field will be highlighted. Press the Navigation Key down to select alarm options.

#### ALARM

Press the Navigation Key left or right to select **On/Off**.

#### TIME

Use the keypad to set a time for the alarm and press Left Soft Key **am/pm**.

#### FREQUENCY

Press the Navigation Key left or right to select a setting for the alarm (**Once**, **Daily**, **Mon - Fri**, **Weekends**).

#### RINGER

Press Left Soft Key **Set**, to use the keypad to 1. Get New Ringtones or select the alert tone you wish to set.

3. To save an alarm setting, press **Save**.

#### TURN ON/OFF THE ALARM SETTING

1. Select existing alarm entry. > Press Right Soft Key **Options** > **1. Turn On/1. Turn Off**.

#### RESET THE ALARM SETTING

1. Select existing alarm entry. > Press Right Soft Key **Options** > **2. Reset Alarm** > **Yes** > **OK**.

#### RESET ALL ALARM SETTING

1. Press Right Soft Key **Options** > **2. Reset All** > **Yes** > **OK**.

#### WORLD CLOCK

(Menu > Settings & Tools > 2 > 5)

To display the time and date in pre-programmed cities:

1. Press Left Soft Key **Cities** to access the **CITIES LIST**. Press the Navigation Key up or down to select the city, then press **OK**. Or, press the Navigation Key up, down, left, or right to select your city using the world map.
2. The world map appears with the city, its date and time.

## DST (DAYLIGHT SAVING TIME) SETTING

1. Press Right Soft Key **DST** to set the DST options. Press the Navigation Key left or right to select City. > Press the Navigation Key down.
2. Press the Navigation Key left or right to turn DST (Daylight Savings Time) **On/Off**. > Press the Navigation Key down.

### START DATE

Use the keypad to change or enter the start date.

### START TIME

Use the keypad to set a start time and press Left Soft Key **am/pm**.

### END DATE

Use the keypad to change or enter the end date.

### END TIME

Use the keypad to set a end time and press Left Soft Key **am/pm**.

3. To save an DST setting, press **Save**.

## NOTEPAD

(Menu > Settings & Tools > 2 > 6)

Your phone includes an internal notepad that can be used to compose and store reminders and notes.

### ADD NEW MEMO

To compose a memo (there is an 80-letter limit):

1. To add a new memo, press Left Soft Key **New**. Input a new text memo. > **Save**.

### VIEW SAVED MEMO

To view a saved memo:

1. The list of all memos, in saved order, is displayed. Select a memo. > **View**.

### ERASE SAVED MEMO

To erase a saved memo:

1. The list of all memos, in saved order, is displayed. Select a memo. > Press Right Soft Key **Options** > **Erase** > **Yes** > **OK**.

## ERASE ALL SAVED MEMO

To erase all saved memo:

1. The list of all memos, in saved order, is displayed. > Press Right Soft Key **Options** > **Erase All** > **Yes** > **OK**.

## STOP WATCH

(Menu > Settings & Tools > 2 > 7)

Simultaneously times up to eight different events. To operate the stop watch:

### TO MEASURE A TIME PERIOD

1. To start the stop watch, press **Start**.
2. To pause it, press **Stop**.
3. To resume it, press **Start**.
4. To reset it, press Right Soft Key **Reset**.

### TO TIME UP TO EIGHT EVENTS AT ONCE:

1. To start the stop watch, press **Start**.
2. To stop a time period and continue measuring another one, press Left Soft Key **Cont**.

3. To stop the second and continue measuring a third one, press Left Soft Key **Cont**.
4. To measure up to eight time periods, repeat the above steps.
5. To stop the stop watch, press **Stop**.
6. To review the results, press Left Soft Key **View**.
7. To return to the stop watch, press **OK**.
8. To reset it, press Right Soft Key **Reset**.

## MY ACCOUNT

(Menu > Settings & Tools > 1)

To access your Verizon account information:

1. Connect "WAP Browser".

## CHAPTER 5

# MEDIA CENTER

Your phone provides a unique feature -Media Center- that enables you to download ringtones, wallpapers, games and more from your network to your phone. Please contact your service provider for the availability of these services.

- Using the microSD card
  - Music & Tones
  - Pictures
  - Games
  - Bobile Web
  - Browse & Download
  - Extras
  - Media center info

## USING THE microSD CARD

The microSD card stores sounds, images, photos and videos, music, and other files.

### INSTALLING THE microSD CARD

To install your MicroSD card, use the following steps:

1. With the microSD card slot opened, and the gold contacts facing down, insert the microSD card into the slot.
2. Push the card in until it clicks into place. Close the microSD card slot.

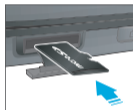

 To prevent possible damages, please keep microSD card slot closed at all times whether microSD card is inserted or not.

### REMOVING THE microSD CARD

To remove the MicroSD card, use the following steps:

1. Open the microSD card slot. Use your thumb to press and release the microSD card. It will pop-out to allow you to remove the card.

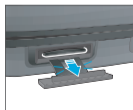

2. Remove the card and close the microSD card slot.

- When you insert the microSD card, make sure contact terminals face down.
- File names storing each media in the microSD card are "my\_pix" for pictures, "my\_flix" for videos, "my\_music" for musics, "my\_sound" for sounds.
- Do not remove the microSD card while reading or writing files. Otherwise it could be damaged.

 To ensure the proper function of removable memory, please use a microSD card.

### HOW IS MUSIC TRANSFERRED?

	Transfer from PC to Handset via USB Cable	Transfer from PC to Handset via Memory card
MP3 Songs	Yes	Yes
WMA Songs (Music ripped from CDs, e.g. unprotected content)	Yes	Yes
WMA Songs (Purchased from a Windows Media Player 10 music store such as V CAST Music, e.g. protected content)	Yes	Song will not play on the phone



- Music acquired from another online store as part of a subscription service or purchased in another format other than WMA/MP3 (e.g. AAC, AAC+) will not be recognized by V CAST Music devices.
- Only MP3 files with 192kbps or higher bitrate will be converted into WMA files.

## MUSIC & TONES

(Menu > Media Center > 1)

To access the Music & Tones menu.

### GET NEW RINGTONES

(Menu > Media Center > 1 > 1)

1. If you have not downloaded any ringtones or ringtone applications previously, press "1. Get New Applications". The Media Center browser will launch. From the Download menu, select a service provider and press OK. Then select the application and press OK to download it.
2. To download a ringtone, select the application from the Get New Ringtones menu. Once the application has launched, follow the directions to download your ringtones. Downloaded ringtones are saved to the My Ringtones menu.

## MY RINGTONES

(Menu > Media Center > 1 > 2)

### TO PLAY DOWNLOADED TUNES OR TONES:

1. Select the tunes or tones you want to play. > Play.

### TO ERASE DOWNLOADED TUNES OR TONES:

1. Select the tunes or tones you want to erase, press Right Soft Key Options > Erase > Yes > OK.
  - If "Downloaded Ringtone" selected, pressing Right Soft Key Options, you can choose from the following:
    1. Erase: Erase the current ringtone from your phone.
    2. Rename: To edit the ringtone's title.
    3. Lock: Lock/Unlock the current ringtone from your phone.
    4. Erase All: To erase all the ringtones in your phone.
    5. File Info: Displays information on the selected ringtone.
  - If "Preloaded Sound" selected, pressing Right Soft Key Options, you can choose from the following:
    1. Erase: Erase the current ringtone from your phone.
    2. Erase All: To erase all the ringtones in your phone.
    3. File Info: Displays information on the selected ringtone.

**TO ASSIGN DOWNLOADED TUNES OR TONES:**

1. Select the tunes or tones you want to assign and then press Left Soft Key **Set As**.
2. Select "Ringtone", "Contact ID" or "Alert Sounds" > **OK**.
  - Pressing Right Soft Key **Options**, you can choose from the following:
    1. Ringtone
    2. Contact ID
    3. Alert Sounds - 1. All Messages  
2. TXT Message  
3. Pic-Voice Message  
4. Voicemail

**MY MUSIC**

(Menu &gt; Media Center &gt; 1 &gt; 3)

1. The Music Library screen appears in the display. The following options appear in the display:
  - 1. Genres / • 2. Artists / • 3. Albums / • 4. Songs / • 5. Playlists / • 6. Inbox / • 7. Play All / • 8. Shuffle
2. If **4 Key Songs** is selected, scroll through the list of downloaded songs then press **PLAY**. If **5 Key Playlists** is selected, scroll through the list of saved playlists then press **PLAY**. Or, press **7 Key Play All**, or **7 Key Shuffle**.

3. Press Left Soft Key **Mute** to mute the song. Press Right Soft Key **Options** to 1. **Play All**, 2. **Shuffle**, 3. **Get V Cast Music** or 4. **Buy Music by Artist**.
4. Press the Navigation Key left to start the song over again. Press the Navigation Key right to skip to the next song if there are other songs to be played. Press **OK** to pause or play the song.

**TO DOWNLOAD MORE MUSIC:**

1. Press Left Soft Key **Catalog**. You will connect to the V Cast Music service.

**MY SOUNDS**

(Menu &gt; Media Center &gt; 1 &gt; 4)

**TO PLAY DOWNLOADED SOUNDS:**

1. Select the sound you want to play. > **Play**.

**TO ERASE DOWNLOADED SOUNDS:**

1. Select the sound you want to erase, press Left Soft Key **Erase** > **Yes** > **OK**.

**TO SEND THE PICTURE MESSAGE:**

1. Select the sound you want to send message, press Right Soft Key **Options** > **Send**.
  - If "Downloaded or Record Sound" selected, pressing Right Soft Key **Options**, you can choose from the following:
    1. **Send**: To send a sound.
    2. **To PIX Place**: To upload selected sound to picture server.
    3. **Rename**: To edit the sound's title.
    4. **Move**: To move the selected sound to the other save location.
    5. **Lock/Unlock**: To select "Lock" or "Unlock".
    6. **Erase All**: To erase all the sounds in your phone.
    7. **File Info**: Displays information on the selected sound.
  - If "Preloaded Sound" selected, pressing Right Soft Key **Options**, you can choose from the following:
    1. **Send**: To send a sound.
    2. **To PIX Place**: To upload selected sound to picture server.
    3. **File Info**: Displays information on the selected sound.

**TO PLAY DOWNLOADED SOUNDS:**

1. Press "**1. Record New**". "Press OK to start recording" will be displayed.
2. Press **OK** to begin recording. When done, press **Stop** to finish recording. The recording is automatically saved to your My Sounds

list.

**SYNC MUSIC**

(Menu &gt; Media Center &gt; 1 &gt; 5)

1. Open Windows Media™ Player 10 on your PC and select the "Sync" tab.
2. Select "Edit Playlist" and select the songs from your library that you want to sync.
3. In Windows Media Player 10, select "V CAST Mobile Phone - Removable Storage Card" unless no memory card is available. Start the sync process in Windows Media Player 10 by pressing "Start Sync". Remember, your phone must be in "Sync Music" mode.
4. When syncing completes, disconnect the cable from your phone and exit "Sync Music".
5. Under the "Music & Tones" menu, open "My Music" to view and play your music.



V CAST Music phones only support music imported from a CD via Windows Media™ Player 10, purchased from the V CAST Music Service, or other purchased Windows Media™ formatted music. iPod® and iTunes® compatible music files are not compatible with V CAST Music.



## PICTURES

(Menu > Media Center > 2)

### GET NEW PICTURES

(Menu > Media Center > 2 > 1)

1. If you have not downloaded any ringtones or ringtone applications previously, press "1. Get New Applications". The Media Center browser will launch. From the Download menu, select a service provider and press **OK**. Then select the application and press **OK** to download it.
2. After executing the downloaded application, download the desired Picture. (The downloaded contents are saved in **My Pictures**.)

### MY PICTURES

(Menu > Media Center > 2 > 2)

In Review Mode you can view all the pictures you have taken, store selected images in your phone, send pictures to the Online Album, delete images and access additional picture options.

1. In Review Mode, you can view all the pictures you have stored in your phone.
2. Select the picture by pressing the Navigation Key up or down. > **View**.

- If "Downloaded or Taken Picture" selected, pressing Right Soft Key **Options**, you can choose from the following:

1. **Send**: To send a picture message.
2. **Set As**: Assigns the selected picture to display for specific tasks. (Wallpaper/Picture ID)
3. **To PIX Place**: To upload selected picture to picture server.
4. **Take Picture**: To take new picture.
5. **Get New Pictures**: To download new picture.
6. **Rename**: To edit the picture's title.
7. **Move**: To move the selected picture to the other save location.
8. **Lock/Unlock**: To set "Lock" or "Unlock".
9. **Erase All**: To erase all the pictures in your phone.
10. **File Info**: Displays information on the selected picture, such as "File Name", "Date", "Time", "Resolution", "Size".

- If "Preloaded PIX" selected, pressing Right Soft Key **Options**, you can choose from the following:

1. **Set As**: Assigns the selected picture to display for specific tasks. (Wallpaper/Picture ID)
2. **Take Picture**: To take new picture.
3. **Get New Pictures**: To download new picture.
4. **Erase All**: To erase all the pictures in your phone.
5. **File Info**: Displays information on the selected picture, such as "File Name", "Date", "Time", "Resolution", "Size".

### TO ERASE THE CURRENT PICTURE:

1. Select the picture you want to erase, press Left Soft Key **Erase** > **Yes** > **OK**.

### TO VIEW THE PREVIOUS OR NEXT PICTURE IN DETAIL VIEW:

1. In detail view mode, press the Navigation Key up, down, left or right.

### TAKE PICTURE

(Menu > Media Center > 2 > 3)

1. To access the camera, press **Side Camera** Key or press and hold **Side Camera** Key when slide is closed.
2. Point the camera lens at your subject. You can check the picture framing through the main display screen.
  - Press the Navigation Key left/right: Zoom Left/Right. (Except 1280X960, 960X1280 mode).
  - Pressing Right Soft Key **Options**, you can choose from the following:
    1. **Resolution**: To select a resolution for a picture.  
(Landscape: 1280x960/640x480/320x240/160x120, Portrait: 960x1280/480x640/240x320/120x160)
    2. **Self Timer**: To activate the camera's timer function.  
(Off/3 Seconds/5 Seconds/10 Seconds)
    3. **Brightness**: To brightness up/down(-2, -1, 0, +1, +2).
    4. **White Balance**: To select white balance.  
(Auto/Sunny/Cloudy/Tungsten/Fluorescent/Darkness)
    5. **Shutter Sound**: To select a shutter sound. (Shutter/Silent/Say "Cheez"/Ready! 123)
    6. **Color Effects**: To select color effect among the following:  
(Normal/Antique/Black and White/Negative)
    7. **Capture Mode**: To select Capture mode "Landscape" or "Portrait".



To view captured images, press Left Soft Key **My Pic**.

3. Press **Side Camera** Key or press **TAKE** to take the picture.
4. After taking the picture it will be displayed. To save the picture, press Left Soft Key **Save**. To take another picture without saving the picture you just took, press Right Soft Key **Erase**. To send the picture to someone, press **SEND**.

### PIX PLACE

(Menu > Media Center > 2 > 4)

1. To connect "WAP Browser".

## GAMES

(Menu > Media Center > 3)

### DOWNLOADING NEW GAMES

(Menu > Media Center > 3 > 1)

1. If you have not downloaded any ringtones or ringtone applications previously, press "1. Get New Applications". The Media Center browser will launch. From the Download menu, select a service provider and press **OK**. Then select the application and press **View**.

## PLAYING DOWNLOADED GAMES

1. To play the game you downloaded, select the game. > [Play](#).

## MOBILE WEB

(Menu > Media Center > 4)

Now you can access news, sports, weather, and e-mail from your phone. Mobile Web 2.0 keeps you updated by providing access to up-to-date information such as news, sports, weather and stock quotes when you subscribe to Internet service with your service provider. Please contact your service provider for a list of available websites and service details.

1. To start your Internet browser and access websites through your wireless handset press the Navigation Key up.

## BROWSER MENU

The browser menu lists the actions necessary to operate the browser. To access, press the Navigation Key up and then press Right Soft Key [Menu](#).

### VZW HOME

(Menu > Media Center > Menu > 1)

Returns the user to the home page.

### ADD FAVORITE

(Menu > Media Center > Menu > 2)

Takes user to the VZW Add Favorite page.



For favorites, page name and URL need to auto-populate.

## SEARCH

(Menu > Media Center > Menu > 3)

Takes user to the VZW Search page.

## GO TO URL

(Menu > Media Center > Menu > 4)

Takes user to the VZW Search > Go to Site page.

## SHOW URL

(Menu > Media Center > Menu > 5)

Displays the current URL.

## BACK

(Menu > Media Center > Menu > 6)

Provides the ability to redisplay the page previously displayed.

## MANAGE MEMORY

(Menu > Media Center > Menu > 7)

Displays the following list of options:

- **Clear Cache:** Clears the cache.
- **Clear History:** Clears the list of recently visited URLs.
- **Clear Cookies:** Clears saved cookies.
- **Autofill:** Automatically fills in character for browser recognized words.

## SETTINGS

(Menu > Media Center > Menu > 8)

- **Downloads:** Selecting the "Downloads" item allows the user to enable/disable downloading images, background sounds, and object downloads when a URL is accessed.

- **Restart Browser:** Selecting "Restart Browser" causes the history and cache to be cleared and returns the user to the homepage.
- **Scroll Mode:** Selecting "Scroll Mode" from the Settings menu allows the user to select the way text scrolls and the scroll speed.
- **Send Referrer:** When the "Send Referrer" item is selected from the Settings menu, the browser allows the user to turn on or off sending the referrer URL.
- **Key Press Time Out:** When the "Key Press Timeout" item is selected from the Settings menu, the browser allows the user to set the key press timeout as fast, medium or slow. Medium is 1.5 seconds, slow 2 seconds and fast is 1 second. The key press timeout is the period of time after which the cursor auto-advances to the next entry position. In most cases, a single key can be used to enter more than one character. Each time the key is pressed the last character of the line is replaced by the next choice for that key. As long as the same key is repressed within key press timeout, the last character cycles between all the choices for the key.
- **Connection Time Out:** When the Connection Timeout item is selected from the Settings menu, the browser allows the user to set the connection timeout. The connection timeout determines how long the browser will wait for a response from the network for a network request.

## ADVANCED

(Menu > Media Center > Menu > 9)

- **About:** Displays the name of the supplier of the Browser and the Browser SW version.
- **Refresh:** Allows the user to reload the current URL.
- **History:** Displays the previous 20 number of visited URLs, where X=20.
- **Encryption:** Displays the following list of options.
  1. **Authentication:** Gives the option to turn Authentication Caching ON or OFF.

2. **Root Certificate:** Shows the root security keys for TLS.

3. **Current Certificate:** Shows the current site security key for TLS (if applicable).

## EXIT

Press **END** Key to exit out of the browser and return to idle mode.

## BROWSE & DOWNLOAD

(Menu > Media Center > 5)

## DOWNLOADING NEW APPLICATIONS

(Menu > Media Center > 5 > 1)

1. If you have not downloaded any ringtones or ringtone applications previously, press "1. [Get New Applications](#)". The Media Center browser will launch. From the Download menu, select a service provider and press **OK**. Then select the application and press **OK** to download it.

## EXTRAS

(Menu > Media Center > 6)

## DOWNLOADING NEW APPLICATIONS

(Menu > Media Center > 6 > 1)

1. If you have not downloaded any ringtones or ringtone applications previously, press "1. [Get New Applications](#)". The Media Center browser

will launch. From the Download menu, select a service provider and press **OK**. Then select the application and press **OK** to download it.

### **MEDIA CENTER INFO** (Menu > Media Center > Info)

Displays information about "App. Memory", "Phone Memory", "View Log" and "Help":

1. Select one of the following options by pressing the Navigation Key up or down:
  - App. Memory / • Phone Memory / • View Log / • Help

## **MESSAGING MENU**

This chapter addresses Voice Mail, TXT, Picture, Video Messaging functions including:

When a new message arrives

- New message
- Inbox
- Sent
- Drafts
- Voicemail
- Mobile IM
- E-Mail
- Chat
- Erase all
- Settings

## WHEN A NEW MESSAGE ARRIVES

- The following display appears when a new message arrives.
- To display the message, select "View Now" and then press **OK**.



## NEW MESSAGE

(Menu > Messaging > 1)

### TXT MESSAGE

(Menu > Messaging > 1 > 1)

- Under "To", input the phone number and then press **OK**.
  - Pressing Right Soft Key **Add**, you can choose from the following:
    - From Contacts:** Search for a phone number which is stored in the contacts list.
    - Recent Calls:** Search the phone number which is stored in the recent calls list.
    - Groups:** Search the groups stored in the contacts list.
    - To Contacts:** Save the number or email you've entered to the contacts list.
- Under "Message", input a new TXT message. > **SEND**.
  - Pressing Right Soft Key **Options**, you can choose from the following:
    - Save As Draft:** To save the TXT message.
    - Add:** To attach Quick Text, Graphic, Sound, Name Card.
      - Quick Text:** Inserts already written sentences in TXT message.
      - Graphic:** Inserts simple graphic image in TXT message.
      - Sound:** Inserts EMS sound in TXT message.

- Name Card:** Inserts name card in TXT message.
- Edit Text Format:** Allows you to edit the Alignment, Font Size, Font Style, Font Color, Background Color.
    - Alignment:** Select "Left", "Center" or "Right" with the Navigation Key left or right.
    - Font Size:** Select "Small", "Normal" or "Large" with the Navigation Key left or right.
    - Font Style:** Select "Strikethrough", "Normal", "Bold", "Italic" or "Underline" with the Navigation Key left or right.
    - Font Color:** Select Font color with the Navigation Key left or right.
    - Background Color:** Select Background color with the Navigation Key left or right.
  - Priority Level:** Select "High" or "Normal" with the Navigation Key up or down.
  - Cancel Message:** To cancel message.



- If one of the fields is inserted in TXT message field, the message is saved in the draft box.
- Input at least one TXT message field to save in the draft box.

### PICTURE MESSAGE

(Menu > Messaging > 1 > 2)

- Under "To", input the phone number and then press **OK**.
  - Pressing Right Soft Key **Add**, you can choose from the following:
    - From Contacts:** Search for a phone number which is stored in the contacts list.
    - Recent Calls:** Search the phone number which is stored in the recent calls list.
    - Groups:** Search the groups stored in the contacts list.
    - To PIX Place:** To send Picture message by using online Address.
- Under "Text", input a new TXT message and then press the Navigation Key down.

- Under "Picture", user can insert/remove only one picture. Press Left Soft Key **My Pics**, select picture you'd like to send. > **OK**.
- Under "Sound", user can insert/remove only one sound. Press Left Soft Key **Sounds**, select the sound you'd like to send. > **OK**.
- Under "Subject", input a subject and then press the Navigation Key down.
- Under "Name Card", you can insert your name card. Press Left Soft Key **Add**, select "My Name Card" or "Contacts". > **OK**. Select the card you'd like to send. > **OK**.
  - Pressing Right Soft Key **Options**, you can choose from the following:
    - Preview:** To preview a written picture message.
    - Save As Draft:** To save the TXT message.
    - Add Slide:** To add a another message.
    - Priority Level:** Select "High" or "Normal" with the Navigation Key up or down.
    - Remove Name Card:** To remove inserted Name Card.
    - Cancel Message:** To cancel message.
- To send the Picture message, press **SEND**.
  - If one of the fields is inserted in TXT message field, the message is saved in the draft box.
  - Input at least one TXT message field to save in the draft box.



## VOICE MESSAGE

(Menu > Messaging > 1 > 3)

- Under "To", input the phone number and then press **OK**.
  - Pressing Right Soft Key **Add**, you can choose from the following:
    - From Contacts:** Search for a phone number which is stored in the contacts list.
    - Recent Calls:** Search the phone number which is stored in the recent calls list.
    - Groups:** Search the groups stored in the contacts list.
    - To PIX Place:** To send Voice message by using online Address.
- Under "Voice", record a new voice memo > **OK**. Press the Navigation Key down.
- Under "Text", input a new TXT message and then press the Navigation Key down.
- Under "Subject", input a subject and then press the Navigation Key down.
- Under "Name Card", you can insert your name card. Press Left Soft Key **Add**, select "My Name Card" or "Contacts". > **OK**. Select the card you'd like to send. > **OK**.
  - Pressing Right Soft Key **Options**, you can choose from the following:
    - Review:** To preview a written voice message.
    - Save As Draft:** To save the TXT message.
    - Add Quick Text:** Inserts already written sentences in TXT message.
    - Priority Level:** Select "High" or "Normal" with the Navigation Key up or down.

**5. Remove Name Card:** To remove inserted Name Card.

**6. Cancel Message:** To cancel message.

6. To send the Voice message, press **SEND**.

- If one of the fields is inserted in TXT message field, the message is saved in the draft box.
- Input at least one TXT message field to save in the draft box.

## INBOX (Menu > Messaging > 2)

The Inbox manages received TXT, Picture, Voice, Web Alert messages. To access:

1. Select a message and then press **OPEN**. The message is displayed. To delete a message, press Left Soft Key **Erase**, press **OK**. When you select **WAP PUSH** message, press **OK**, to launch the browser.



2. Press Right Soft Key **Options**.

- **Play Again:** To play a received Picture/Voice message.
- **Reply:** Type your reply.
- **Erase Inbox:** To erase all inbox message.
- **Reply W. Copy:** Select to reply with the original message included.
- **Forward:** Select to forward the TXT or Picture/Voice message.

- **Save Picture (MMS Picture):** Select to save a picture to the "My Pictures" folder.
- **Save As Ringtone:** Select to save a sound to the "My Ringtones" folder.
- **Save Sound (MMS Sound):** Select to save a sound to the "My Sounds" folder
- **Save Objects (EMS Save Objects):** Select to save a graphic, sound, name card.
- **Save Name Card:** Select to save a name card to the contacts.
- **Save Quick Text:** Select to save received text msg to "Quick Text".
- **Add To Contacts:** Select to save number to contacts.
- **Lock/Unlock:** Select to lock or unlock the TXT, Picture or Voice message.
- **Message Info:** Select to show received TXT/Picture/Voice message information.

## SENT (Menu > Messaging > 3)

Manages TXT, Picture, Voice messages or messages waiting to be sent.

1. Select a message and then press **OPEN**. The message is displayed. To delete a message, press Left Soft Key **Erase** > **OK**.



2. Press Right Soft Key **Options**.

- **Forward:** Select to forward the TXT or Picture/Voice message.
- **Play Again:** Select to play sent MMS message.
- **Resend:** Select to resend a TXT, Picture or Voice message.
- **Erase:** To erase a selected message.
- **Erase Sent:** To erase all sent message,
- **Add To Contacts:** Select to save number to contacts.

- **Lock/Unlock:** Select to lock or unlock the TXT, Picture or Voice message.
- **Save Quick Text:** Select to save sent text msg to "Quick Text".
- **View Name Card:** To view include name card with in message.
- **Message Info:** Select to show received TXT/Picture/Voice message information.

## DRAFTS (Menu > Messaging > 4)

Draft Folder contains any draft messages or saved messages. If message composition is interrupted by a voice call or other interrupting event, the text of the current composition is automatically saved in the drafts folder.

1. Select a message and then press **EDIT**. The message is displayed. To delete a message, press Left Soft Key **Erase**, press **OK**.



2. Press Right Soft Key **Options**.

- **Send:** Select to send a selected message.
- **Lock/Unlock:** Select to lock or unlock the TXT, Picture or Voice message.
- **Add To Contacts:** Select to save number to contacts.
- **Erase Drafts:** To erase all drafts messages.

## VOICEMAIL (Menu > Messaging > 5)

New voicemail alerts are sent via an SMS text message. These messages indicate how many new and urgent voicemails are in your voicemail box. Open the text message to view the number of new voice messages in your

voicemail. If a caller leaves a callback number, this number will also be sent via an SMS text message. Displays the number of voice mails and accesses them by press and hold **SEND Key**.

## TO ACCESS YOUR VOICE MAILBOX

1. To dial voice mail directly, press \* Key, 8 Key, 6 Key and then **SEND Key**.
2. Follow the prompts to enter your lock code and retrieve your messages.

If you hear your own system greeting when you dial \*VM (\* Key, 8 Key, 6 Key), press to interrupt it and follow the prompts to enter your lock code.

## VOICE MAIL SETUP

1. To dial voice mail directly, press \* Key, 8 Key, 6 Key and then **SEND Key**. (If calling from a touch-tone phone, enter your wireless number.)
2. If you hear a greeting, press \* Key to precede.

You will be charged airtime for using your wireless phone to set-up or retrieve voice mail. Toll and/or long distance charges may also apply.

3. Follow the prompts to personalize your lock code, **GREETING**, & **MAILBOX OPTIONS**.

## VOICE MAIL RETRIEVAL

- To dial voice mail directly, press **\* Key, 8 Key, 6 Key** and then **SEND Key**. (To access your voice mail from outside the Verizon Wireless network or from a touch-tone phone, enter your wireless number.)
- If you hear a greeting, press **# Key** to precede.



You will be charged airtime for using your wireless phone to set-up or retrieve voice mail. Toll and/or long distance charges may also apply.

- Enter your lock code and press **# Key**.

## VOICE MAIL SHORTCUTS

### • While Listening to a Message Press:

- 1 Key:** Rewind / **2 Key:** Pause / **3 Key:** Fast Forward / **4 Key:** Slower / **5 Key:** Envelope Info (date/time) / **6 Key:** Faster / **\* Key:** Cancel / **0 Key:** Help / **# Key:** Finish/Skip / **1 Key + 1 Key:** Rewind to Beginning / **3 Key + 3 Key:** Fast Forward to End / **7 Key:** Delete Message

### • After Listening to a Message Press:

- 4 Key:** Replay / **7 Key:** Delete / **9 Key:** Save / **0 Key:** Help

## MOBILE IM

(Menu > Messaging > 6)

### LAUNCHING MOBILE IM

- Press Left Soft Key **Message**, then **6. Mobile IM**, and then press **"Mobile IM"** for Preloaded Mobile IM.



- Choose from AIM® Instant Messenger™ Service, MSN® Messenger Service and Yahoo!® Messenger.



- Choose passport and enter Sign-In name and password.

### DOWNLOAD NEW IM APPLICATIONS

- Press Left Soft Key **Message**, then **6. Mobile IM**, and then **1. Get New Applications**.



## E-MAIL

(Menu > Messaging > 7)

- Press Left Soft Key **Message**, then **7. E-Mail**.
- Browser launches.

## CHAT

(Menu > Messaging > 8)

- Press Left Soft Key **Message**, then **8. Chat**.
- Browser launches.

## ERASE ALL

(Menu > Messaging > Options)

- Press Left Soft Key **Message**, then Right Soft Key **Options**.
  - **Erase Inbox:** To erase all the inbox messages. > Yes > OK.
  - **Erase Drafts:** To erase all the drafts messages. > Yes > OK.
  - **Erase Sent:** To erase the sent messages. > Yes > OK.
  - **Erase All:** To erase all messages. > Yes > OK.

## SETTINGS

(Menu > Messaging > Settings)

Sets messaging preferences and default settings.

### ENTRY MODE

(Menu > Messaging > Settings > 1)

Sets an Entry Mode as a default. For example, if Word Mode is the default, its icon will appear.

- Select **"Abc", "ABC" or "123"** with the Navigation Key up or down. > OK.

### AUTO SAVE

(Menu > Messaging > Settings > 2)

- Select **"On", "Off" or "Prompts"** with the Navigation Key up or down. > OK.
  - **On:** All sent messages saved in the Sent box.
  - **Off:** All sent messages not saved in the Sent box.
  - **Prompts:** "Yes", "No" dialogue box displayed after sent message.

### AUTO ERASE

(Menu > Messaging > Settings > 3)

Automatically erases inbox messages when new messages arrive.

- Select **"On" or "Off"** with the Navigation Key up or down. > OK.
  - **On:** Oldest message erased from inbox automatically when Inbox is full.
  - **Off:** Oldest message not erased from inbox automatically when Inbox is full.

**TXT AUTO VIEW** (Menu > Messaging > Settings > 4)

1. Select "On" or "Off" with the Navigation Key up or down.> **OK**.
  - **On:** TXT message displayed automatically.
  - **Off:** TXT message displayed by going to the inbox or responding to interactive notification.

**PIC-VOICE AUTO RECEIVE** (Menu > Messaging > Settings > 5)

1. Select "On" or "Off" with the Navigation Key up or down.> **OK**.
  - **On:** Picture/Voice message downloaded automatically.
  - **Off:** Picture/Voice message must be retrieved from the inbox or at new Picture/Voice Message prompt.

**QUICK TEXT** (Menu > Messaging > Settings > 6)

To edit the Quick Text you have saved:

1. Select a message from the list. > **OK**.
2. To add a new Quick Text, press Right Soft key **New** > Enter text > **OK**.
3. To erase the saved Quick Text, press Left Soft Key **Erase** > **Yes** > **OK**.

**VOICEMAIL#** (Menu > Messaging > Settings > 7)

1. Input a new voice call back number or edit voice call back number.> **OK**.

**CALLBACK #** (Menu > Messaging > Settings > 8)

Edits a default callback number so that the recipient can callback or reply.

1. Select "On" or "Off" with the Navigation Key up or down.> **OK**.
2. If "On" selected, input a new callback number. > **OK**.

**SIGNATURE** (Menu > Messaging > Settings > 9)

Create a signature that can be automatically inserted at the end of all TXT, Picture and Voice messages.

1. To activate Signature function, put the cursor on Insert Signature then select "Custom" by using up or down direction keys. To deactivate Signature function, select "None".
2. To input "Signature", put the cursor on Edit Signature and then enter Signature Edit window by using right or left direction keys. > **OK**.

**SAFETY AND WARRANTY**

This chapter addresses the safety guidelines and precautions to follow when operating your phone. Before operating your phone, please be aware of all the safety details. This chapter contains the terms and conditions of services and the warranty for your phone. Please review them thoroughly.

Safety information for wireless handheld phones  
 Safety information for FCC RF exposure  
 SAR information

FCC hearing-aid compatibility (HAC) regulations for wireless devices  
 FDA consumer update

Avoid potential hearing loss.  
 12 month limited warranty  
 Index list

## SAFETY INFORMATION FOR WIRELESS HANDHELD PHONES

### READ THIS INFORMATION BEFORE USING YOUR HANDHELD PORTABLE CELLULAR TELEPHONE

#### EXPOSURE TO RADIO FREQUENCY SIGNALS

Your wireless handheld portable telephone is a low power radio transmitter and receiver. When it is ON, it receives and also sends out radio frequency (RF) signals.

In August 1996, the Federal Communications Commissions (FCC) adopted RF exposure guidelines with safety levels for handheld wireless phones. Those guidelines are consistent with the safety standards previously set by both U.S. and international standards bodies:

- ANSI C95.1 (1992) \*
- NCRP Report 86 (1986) \*
- ICNIRP (1996) \*

Those standards were based on comprehensive and periodic evaluations of the relevant scientific literature. For example, over 120 scientists, engineers, and physicians from universities, government health agencies, and industry reviewed the available body of research to develop the ANSI Standard (C951).

The design of your phone complies with the FCC guidelines (and those standards).

- 1\* : American National Standards Institute.
- 2\* : National Council on Radiation protection and measurements.
- 3\* : International Commission on Nonionizing Radiation Protection.

#### ANTENNA SAFETY

Use only the supplied or an approved replacement antenna. Unauthorized antennas, modifications, or attachments could impair call quality, damage the phone, or result in violation of FCC regulations. Please contact your local dealer for replacement antenna.

Do not use the phone with a damaged antenna. If a damaged antenna comes into contact with the skin, a minor burn may result. Please contact your local dealer for replacement antenna.

#### DRIVING SAFETY

Talking on the phone while driving is extremely dangerous and is illegal in some states. Remember, safety comes first. Check the laws and regulations on the use of phones in the areas where you drive. Always obey them. Also, if using your phone while driving, please:

- Give full attention to driving. Driving safely is your first responsibility.
- Use hands-free operation, if available.
- Pull off the road and park before making or answering a call, if driving conditions so require.

If you must use the phone while driving, please use one-touch, speed dialing, and auto answer modes.

An airbag inflates with great force. DO NOT place objects, including both installed or portable wireless equipment, in the area over the airbag or in the air bag deployment area. If in-vehicle wireless equipment is improperly installed and the air bag inflates, serious injury could result.



**WARNING:** Failure to follow these instructions may lead to serious personal injury and possible property damage.

#### ELECTRONIC DEVICES

Your wireless handheld portable telephone is a low power radio transmitter and receiver. When it is ON, it receives and also sends out radio frequency (RF) signals.

Most modern electronic equipment is shielded from RF energy. However, certain electronic equipment may not be shielded against the RF signals from your wireless phone. Therefore, use of your phone must be restricted in certain situations.

#### PACEMAKERS

The Health Industry Manufacturers Association recommends that a minimum separation of six (6") inches be maintained between a handheld wireless phone and a pacemaker to avoid potential interference with the pacemaker. These recommendations are consistent with the independent research by and recommendations of Wireless Technology Research. Persons with pacemakers:

- ALWAYS keep the phone more than six inches from your pacemaker when the phone is turned on.
- Do not carry the phone in a breast pocket.
- Use the ear opposite the pacemaker to minimize the potential for interference.
- If you have any reason to suspect that interference is taking place, turn your phone OFF immediately.

#### HEARING AIDS

Some digital wireless phones may interfere with some hearing aids. In the event of such interference, you may want to consult your service provider (or call the customer service line to discuss alternatives).

#### OTHER MEDICAL DEVICES

If you use any other personal medical device, consult the manufacturer of your device to determine if they are adequately shielded from external RF energy. Your physician may be able to assist you in obtaining this information.

Turn your phone OFF in healthcare facilities when any regulations posted in these areas instruct you to do so. Hospitals or healthcare facilities may be using equipment that could be sensitive to external RF energy.

#### VEHICLES

RF signals may affect improperly installed or inadequately shielded electronic systems in motor vehicles. Check with the manufacturer or its representative regarding



your vehicle. You should also consult the manufacturer of any equipment that has been added to your vehicle.

### POSTED FACILITIES

Turn your phone OFF where posted notices so require.

### OTHER SAFETY GUIDELINES

#### AIRCRAFT

FCC regulations prohibit using your phone while in the air. Turn your phone OFF before boarding an aircraft. Always request and obtain prior consent and approval of an authorized airline representative before using your phone aboard an aircraft. Always follow the instructions of the airline representative whenever using your phone aboard an aircraft, to prevent any possible interference with airborne electronic equipment.

#### BLASTING AREAS

To avoid interfering with blasting operations, turn your phone OFF when in a "blasting area" or in areas posted: "Turn off two-way radio." Obey all signs and instructions.

#### POTENTIALLY EXPLOSIVE ATMOSPHERES

Turn your phone OFF when in any area with a potentially explosive atmosphere and

obey all signs and instructions. Sparks in such areas could cause an explosion or fire resulting in bodily injury or even death.

Areas with a potentially explosive atmosphere are often, but not always, clearly marked. They include fueling areas such as gas stations; below deck on boats; fuel or chemical transfer or storage facilities; vehicles using liquefied petroleum gas (such as propane or butane); areas where the air contains chemicals or particles, such as grain, dust, or metal powders; and any other area where you would normally be advised to turn off your vehicle's engine.

#### PRECAUTIONS

Your Handheld Portable Telephone is a high quality piece of equipment. Before operating, read all instructions and cautionary markings on (1) AC/DC Travel Adaptor (2) Battery and (3) Product Using Battery.

Failure to follow the directions below could result in serious bodily injury and/or property damage due to battery liquid leakage, fire or rupture.

- DO NOT use this equipment in an extreme environment where high temperature or high humidity exists.
- DO NOT abuse the equipment. Avoid striking, shaking or shocking. When not using, lay down the unit to avoid possible damage due to instability.
- DO NOT expose this equipment to rain or spilled beverages.
- DO NOT use unauthorized accessories.
- DO NOT disassemble the phone or its accessories. If service or repair is required,

return unit to an authorized UTStarcom cellular service center. If unit is disassembled, the risk of electric shock or fire may result.

- DO NOT short-circuit the battery terminals with metal items etc.



#### WARNING:

- This product contains a chemical known to the State of California to cause cancer.
- This product contains a chemical known to the State of California to cause birth defects or other reproductive harm.

### SAFETY INFORMATION FOR FCC RF EXPOSURE

#### WARNING! READ THIS INFORMATION BEFORE USING

#### CAUTIONS

In August 1996 the Federal Communications Commission (FCC) of the United States with its action in Report and Order FCC 96-326 adopted an updated safety standard for human exposure to radio frequency electromagnetic energy emitted by FCC regulated transmitters. Those guidelines are consistent with the safety standard previously set by both U.S. and international standards bodies. The design of this phone complies with the FCC guidelines and these international standards.

#### BODY-WORN OPERATION

This device was tested for typical body-worn operations with the back of the phone kept 1.5 cm. from the body. To maintain compliance requirements, use only belt-clips, holsters or similar accessories that maintain a

1.5 cm separation distance between the user's Body and the back of the phone including the antenna. The use of belt-clips, holsters and similar accessories should not contain metallic components in its assembly. The use of accessories that do not satisfy these requirements may not comply with FCC RF exposure requirements, and should be avoided.



For more information about RF exposure, please visit the FCC website at [www.fcc.gov](http://www.fcc.gov).

### SAR INFORMATION

#### THIS MODEL PHONE MEETS THE GOVERNMENT'S REQUIREMENTS FOR EXPOSURE TO RADIO WAVES.

Your wireless phone is a radio transmitter and receiver. It is designed and manufactured not to exceed the emission limits for exposure to radiofrequency (RF) energy set by the Federal Communications Commission of the U.S. Government. These limits are part of comprehensive guidelines and establish permitted levels of RF energy for the general population. The guidelines are based on standards that were developed by independent scientific organizations through periodic and thorough evaluation of scientific studies. The standards include a substantial safety margin designed to assure the safety of all persons, regardless of age and health.

The exposure standard for wireless mobile phones employs a unit of measurement known as the Specific Absorption Rate, or SAR. The SAR limit set by the FCC is 1.6 W/kg. \* Tests for SAR are conducted with the phone transmitting at its highest certi-

fied power level in all tested frequency bands. Although the SAR is determined at the highest certified power level, the actual SAR level of the phone while operating can be well below the maximum value. This is because the phone is designed to operate at multiple power levels so as to use only the power required to reach the network. In general, the closer you are to a wireless base station antenna, the lower the power output.

Before a phone model is available for sale to the public, it must be tested and certified to the FCC that it does not exceed the limit established by the government adopted requirement for safe exposure. The tests are performed in positions and locations (e.g., at the ear and worn on the body) as required by the FCC for each model. The highest SAR value for this model phone when tested for use at the ear is 1.19W/Kg and when worn on the body, as described in this user guide, is 0.694 W/Kg. (Body-worn measurements differ among phone models, depending upon available accessories and FCC requirements). While there may be differences between the SAR levels of various phones and at various positions, they all meet the government requirement for safe exposure.

The SAR testing for Body-worn operation was performed with a belt clip that provided a 22mm separation. The User's Manual indicates that any holsters/clips used with this device should contain no metallic components.

The FCC has granted an Equipment Authorization for this model phone with all reported SAR levels evaluated as in compliance with the FCC RF exposure guidelines. SAR information on this model phone is on file with the FCC and can be found

under the Display Grant section of <http://www.fcc.gov/oet/fccid> after searching on PP4ELVIS.

Additional information on Specific Absorption Rates (SAR) can be found on the Cellular Telecommunications Industry Association (CTIA) web-site at <http://www.wow-com.com>.

\* In the United States and Canada, the SAR limit for mobile phones used by the public is 1.6 watts/kg (W/kg) averaged over one gram of tissue. The standard incorporates a sub-stancial margin of safety to give additional protection for the public and to account for any variations in measurements.

## FCC HEARING-AID COMPATIBILITY (HAC) REGULATIONS FOR WIRELESS DEVICES

On July 10, 2003, the U.S. Federal Communications Commission (FCC) Report and Order in WT Docket 01-309 modified the exception of wireless phones under the Hearing Aid Compatibility Act of 1988 (HAC Act) to require digital wireless phones be compatible with hearing-aids. The intent of the HAC Act is to ensure reasonable access to telecommunications services for persons with hearing disabilities.

While some wireless phones are used near some hearing devices (hearing aids and cochlear implants), users may detect a buzzing, humming, or whining noise. Some hearing devices are more immune than others to this interference noise, and phones also vary in the amount of interference they generate.

The wireless telephone industry has developed a rating system for wireless phones, to assist hearing device users find phones that may be compatible with their hearing devices. Not all phones have been rated. Phones that are rated have the rating on their box or a label located on the box.

The ratings are not guarantees. Results will vary depending on the user's hearing device and hearing loss. If your hearing device happens to be vulnerable to interference, you may not be able to use a rated phone successfully. Trying out the phone with your hearing device is the best way to evaluate it for your personal needs.

**M-Ratings:** Phones rated M3 or M4 meet FCC requirements and are likely to generate less interference to hearing devices than phones that are not labeled. M4 is the better/higher of the two ratings.



Hearing devices may also be rated. Your hearing device manufacturer or hearing health professional may help you find this rating. Higher ratings mean that the hearing device is relatively immune to interference noise.

The hearing aid and wireless phone rating values are then added together. A sum of 5 is considered acceptable for normal use. A sum of 6 is considered for best use.

In the above example, if a hearing aid meets the M2 level rating and the wireless phone meets the M3 level rating, the sum of the two values equal M5. This should provide the hearing aid user with "normal usage" while using their hearing aid with the particular wireless phone. "Normal usage" in this context is defined as a signal quality that is acceptable for normal operation.

The M mark is intended to be synonymous with the U mark. The T mark is intended to be synonymous with the UT mark. The M and T marks are recommended by the Alliance for Telecommunications Industries Solutions (ATIS). The U and UT marks are referenced in Section 20.19 of the FCC Rules. The HAC rating and measurement procedure are described in the American National Standards Institute (ANSI) C63.19 standard.

### For information about hearing aids and digital wireless phone

- Fcc Hearing Aid Compatibility and Volume Control <http://www.fcc.gov/cgb/dro/hearing.html>
- Gallaudet University, RERC <http://tap.gallaudet.edu/DigWireless.KS/DigWireless.htm>
- Self Help for Hard of Hearing People Inc. [SHHH] [www.hearingloss.org/hat/TipsWirelessPhones.htm](http://www.hearingloss.org/hat/TipsWirelessPhones.htm)
- The Hearing Aid Compatibility FCC Order [http://hraunfoss.fcc.gov/edocs\\_public/attachmatch/FCC-03-168A1.pdf](http://hraunfoss.fcc.gov/edocs_public/attachmatch/FCC-03-168A1.pdf)

## FDA CONSUMER UPDATE



### U.S. FOOD AND DRUG ADMINISTRATION - CENTER FOR DEVICES AND RADIOLOGICAL HEALTH CONSUMER UPDATE ON WIRELESS PHONES

#### 1. Do wireless phones pose a health hazard?

The available scientific evidence does not show that any health problems are associated with using wireless phones. There is no proof, however, that wireless phones are absolutely safe. Wireless phones emit low levels of radiofrequency energy (RF) in the microwave range while being used. They also emit very low levels of RF when in the stand-by mode. Whereas high levels of RF can produce health effects (by heating tissue), exposure to low level RF that does not produce heating effects causes no known adverse health effects. Many studies of low level RF exposures have not found any biological effects. Some studies have suggested that some biological effects may occur, but such findings have not been confirmed by additional research. In some cases, other researchers have had difficulty in reproducing those studies, or in determining the reasons for inconsistent results.

#### 2. What is FDA's role concerning the safety of wireless phones?

Under the law, FDA does not review the safety of radiation-emitting consumer products such as wireless phones before they can be sold, as it does with new drugs or medical devices. However, the agency has authority to take action if wireless phones are shown to emit radiofrequency energy (RF) at a level that is hazardous to

the user. In such a case, FDA could require the manufacturers of wireless phones to notify users of the health hazard and to repair, replace or recall the phones so that the hazard no longer exists. Although the existing scientific data do not justify FDA regulatory actions, FDA has urged the wireless phone industry to take a number of steps, including the following:

- Support needed research into possible biological effects of RF of the type emitted by wireless phones;
  - Design wireless phones in a way that minimizes any RF exposure to the user that is not necessary for device function;
- and
- Cooperate in providing users of wireless phones with the best possible information on possible effects of wireless phone use on human health.

FDA belongs to an interagency working group of the federal agencies that have responsibility for different aspects of RF safety to ensure coordinated efforts at the federal level. The following agencies belong to this working group:

- National Institute for Occupational Safety and Health
- Environmental Protection Agency
- Federal Communications Commission
- Occupational Safety and Health Administration
- National Telecommunications and Information Administration

The National Institutes of Health participates in some inter-agency working group activities, as well. FDA shares regulatory responsibilities for wireless phones with the

Federal Communications Commission (FCC). All phones that are sold in the United States must comply with FCC safety guidelines that limit RF exposure. FCC relies on FDA and other health agencies for safety questions about wireless phones. FCC also regulates the base stations that the wireless phone networks rely upon. While these base stations operate at higher power than do the wireless phones themselves, the RF exposures that people get from these base stations are typically thousands of times lower than those they can get from wireless phones. Base stations are thus not the subject of the safety questions discussed in this document.

#### 3. What kinds of phones are the subject of this update?

The term "wireless phone" refers here to hand-held wireless phones with built-in antennas, often called "cell," "mobile," or "PCS" phones. These types of wireless phones can expose the user to measurable radiofrequency energy (RF) because of the short distance between the phone and the user's head. These RF exposures are limited by Federal Communications Commission safety guidelines that were developed with the advice of FDA and other federal health and safety agencies. When the phone is located at greater distances from the user, the exposure to RF is drastically lower because a person's RF exposure decreases rapidly with increasing distance from the source. The so-called "cordless phones," which have a base unit connected to the telephone wiring in a house, typically operate at far lower power levels, and thus produce RF exposures far below the FCC safety limits.

#### 4. What are the results of the research done already?

The research done thus far has produced conflicting results, and many studies have

suffered from flaws in their research methods. Animal experiments investigating the effects of radiofrequency energy (RF) exposures characteristic of wireless phones have yielded conflicting results that often cannot be repeated in other laboratories. A few animal studies, however, have suggested that low levels of RF could accelerate the development of cancer in laboratory animals.

However, many of the studies that showed increased tumor development used animals that had been genetically engineered or treated with cancer-causing chemicals so as to be predisposed to develop cancer in the absence of RF exposure. Other studies exposed the animals to RF for up to 22 hours per day. These conditions are not similar to the conditions under which people use wireless phones, so we don't know with certainty what the results of such studies mean for human health. Three large epidemiology studies have been published since December 2000. Between them, the studies investigated any possible association between the use of wireless phones and primary brain cancer, glioma, meningioma, or acoustic neuroma, tumors of the brain or salivary gland, leukemia, or other cancers. None of the studies demonstrated the existence of any harmful health effects from wireless phone RF exposures. However, none of the studies can answer questions about long-term exposures, since the average period of phone use in these studies was around three years.

#### 5. What research is needed to decide whether RF exposure from wireless phones poses a health risk?

A combination of laboratory studies and epidemiological studies of people actually

using wireless phones would provide some of the data that are needed. Lifetime animal exposure studies could be completed in a few years. However, very large numbers of animals would be needed to provide reliable proof of a cancer promoting effect if one exists. Epidemiological studies can provide data that is directly applicable to human populations, but 10 or more years' follow-up may be needed to provide answers about some health effects, such as cancer. This is because the interval between the time of exposure to a cancer-causing agent and the time tumors develop - if they do - may be many, many years. The interpretation of epidemiological studies is hampered by difficulties in measuring actual RF exposure during day-to-day use of wireless phones. Many factors affect this measurement, such as the angle at which the phone is held, or which model of phone is used.

#### **6. What is FDA doing to find out more about the possible health effects of wireless phone RF?**

FDA is working with the U.S. National Toxicology Program and with groups of investigators around the world to ensure that high priority animal studies are conducted to address important questions about the effects of exposure to radiofrequency energy (RF). FDA has been a leading participant in the World Health Organization International Electromagnetic Fields (EMF) Project since its inception in 1996. An influential result of this work has been the development of a detailed agenda of research needs that has driven the establishment of new research programs around the world. The Project has also helped develop a series of public information documents on EMF issues. FDA and the Cellular Telecommunications & Internet Association (CTIA) have a formal Cooperative Research and Development Agreement

(CRADA) to do research on wireless phone safety. FDA provides the scientific oversight, obtaining input from experts in government, industry, and academic organizations. CTIA-funded research is conducted through contracts to independent investigators. The initial research will include both laboratory studies and studies of wireless phone users. The CRADA will also include a broad assessment of additional research needs in the context of the latest research developments around the world.

#### **7. How can I find out how much radiofrequency energy exposure I can get by using my wireless phone?**

All phones sold in the United States must comply with Federal Communications Commission (FCC) guidelines that limit radiofrequency energy (RF) exposures. FCC established these guidelines in consultation with FDA and the other federal health and safety agencies. The FCC limit for RF exposure from wireless telephones is set at a Specific Absorption Rate (SAR) of 1.6 watts per kilogram (1.6 W/kg). The FCC limit is consistent with the safety standards developed by the Institute of Electrical and Electronic Engineering (IEEE) and the National Council on Radiation Protection and Measurement. The exposure limit takes into consideration the body's ability to remove heat from the tissues that absorb energy from the wireless phone and is set well below levels known to have effects. Manufacturers of wireless phones must report the RF exposure level for each model of phone to the FCC. The FCC website (<http://www.fcc.gov/oet/rfsafety>) gives directions for locating the FCC identification number on your phone so you can find your phone's RF exposure level in the online listing.

#### **8. What has FDA done to measure the radiofrequency energy coming from wireless phones?**

The Institute of Electrical and Electronic Engineers (IEEE) is developing a technical standard for measuring the radiofrequency energy (RF) exposure from wireless phones and other wireless handsets with the participation and leadership of FDA scientists and engineers. The standard, "Recommended Practice for Determining the Spatial-Peak Specific Absorption Rate (SAR) in the Human Body Due to Wireless Communications Devices: Experimental Techniques," sets forth the first consistent test methodology for measuring the rate at which RF is deposited in the heads of wireless phone users. The test method uses a tissue-simulating model of the human head. Standardized SAR test methodology is expected to greatly improve the consistency of measurements made at different laboratories on the same phone. SAR is the measurement of the amount of energy absorbed in tissue, either by the whole body or a small part of the body. It is measured in watts/kg (or milliwatts/g) of matter. This measurement is used to determine whether a wireless phone complies with safety guidelines.

#### **9. What steps can I take to reduce my exposure to radiofrequency energy from my wireless phone?**

If there is a risk from these products—and at this point we do not know that there is—it is probably very small. But if you are concerned about avoiding even potential risks, you can take a few simple steps to minimize your exposure to radiofrequency energy (RF). Since time is a key factor in how much exposure a person receives, reducing the amount of time spent using a wireless phone will reduce RF exposure.

- If you must conduct extended conversations by wireless phone every day, you could place more distance between your body and the source of the RF, since the exposure level drops off dramatically with distance.

For example, you could use a headset and carry the wireless phone away from your body or use a wireless phone connected to a remote antenna. Again, the scientific data do not demonstrate that wireless phones are harmful. But if you are concerned about the RF exposure from these products, you can use measures like those described above to reduce your RF exposure from wireless phone use.

#### **10. What about children using wireless phones?**

The scientific evidence does not show a danger to users of wireless phones, including children and teenagers. If you want to take steps to lower exposure to radiofrequency energy (RF), the measures described above would apply to children and teenagers using wireless phones. Reducing the time of wireless phone use and increasing the distance between the user and the RF source will reduce RF exposure. Some groups sponsored by other national governments have advised that children be discouraged from using wireless phones at all. For example, the government in the United Kingdom distributed leaflets containing such a recommendation in December 2000. They noted that no evidence exists that using a wireless phone causes brain tumors or other ill effects. Their recommendation to limit wireless phone use by children was strictly precautionary; it was not based on scientific evidence that any health hazard exists.

## 11. What about wireless phone interference with medical equipment?

Radiofrequency energy (RF) from wireless phones can interact with some electronic devices. For this reason, FDA helped develop a detailed test method to measure electromagnetic interference (EMI) of implanted cardiac pacemakers and defibrillators from wireless telephones. This test method is now part of a standard sponsored by the Association for the

Advancement of Medical Instrumentation (AAMI). The final draft, a joint effort by FDA, medical device manufacturers, and many other groups, was completed in late 2000. This standard will allow manufacturers to ensure that cardiac pacemakers and defibrillators are safe from wireless phone EMI. FDA has tested hearing aids for interference from handheld wireless phones and helped develop a voluntary standard sponsored by the Institute of Electrical and Electronic Engineers (IEEE). This standard specifies test methods and performance requirements for hearing aids and wireless phones so that no interference occurs when a person uses a “compatible” phone and a “compatible” hearing aid at the same time. This standard was approved by the IEEE in 2000. FDA continues to monitor the use of wireless phones for possible interactions with other medical devices. Should harmful interference be found to occur, FDA will conduct testing to assess the interference and work to resolve the problem.

## 12. Where can I find additional information?

For additional information, please refer to the following resources:

- FDA web page on wireless phones (<http://www.fda.gov/cdrh/phones/index.html>)
- Federal Communications Commission (FCC) RF Safety Program (<http://www.fcc.gov/oet/rfsafety>)
- International Commission on Non-Ionizing Radiation Protection (<http://www.icnirp.de>)
- World Health Organization (WHO) International EMF Project (<http://www.who.int/emf>)
- National Radiological Protection Board (UK) (<http://www.nrpb.org.uk/>)

## AVOID POTENTIAL HEARING LOSS.

Prolonged exposure to loud sounds (including music) is the most common cause of preventable hearing loss. Some scientific research suggests that using portable audio devices, such as portable music players and cellular telephones, at high volume settings for long durations may lead to permanent noise-induced hearing loss. This includes the use of headphones (including headsets, earbuds and Bluetooth® or other wireless devices). Exposure to very loud sound has also been associated in some studies with tinnitus (a ringing in the ear), hypersensitivity to sound and distorted hearing. Individual susceptibility to noise-induced hearing loss and other potential hearing problems varies.

The amount of sound produced by a portable audio device varies depending on the nature of the sound, the device, the device settings and the headphones. You should follow some commonsense recommendations when using any portable

audio device:

- Set the volume in a quiet environment and select the lowest volume at which you can hear adequately.
- When using headphones, turn the volume down if you cannot hear the people speaking near you or if the person sitting next to you can hear what you are listening to.
- Do not turn the volume up to block out noisy surroundings. If you choose to listen to your portable device in a noisy environment, use noise-cancelling headphones to block out background environmental noise.
- Limit the amount of time you listen. As the volume increases, less time is required before your hearing could be affected.
- Avoid using headphones after exposure to extremely loud noises, such as rock concerts, that might cause temporary hearing loss. Temporary hearing loss might cause unsafe volumes to sound normal.
- Do not listen at any volume that causes you discomfort. If you experience ringing in your ears, hear muffled speech or experience any temporary hearing difficulty after listening to your portable audio device, discontinue use and consult your doctor.

## YOU CAN OBTAIN ADDITIONAL INFORMATION ON THIS SUBJECT FROM THE FOLLOWING SOURCES:

### American Academy of Audiology

11730 Plaza American Drive, Suite 300  
Reston, VA 20190  
Voice: (800) 222-2336  
Email: [info@audiology.org](mailto:info@audiology.org)  
Internet: [www.audiology.org](http://www.audiology.org)

### National Institute on Deafness and Other Communication Disorders

#### National Institutes of Health

31 Center Drive, MSC 2320  
Bethesda, MD USA 20892-2320  
Voice: (301) 496-7243  
Email: [nidcdinfo@nih.gov](mailto:nidcdinfo@nih.gov)  
Internet: <http://www.nidcd.nih.gov/health/hearing>

### National Institute for Occupational Safety and Health

Hubert H. Humphrey Bldg.  
200 Independence Ave., SW  
Washington, DC 20201  
Voice: 1-800-35-NIOSH (1-800-356-4674)  
Internet: <http://www.cdc.gov/niosh/topics/noise/default.html>

©2008 Verizon Wireless. All Rights Reserved.

## 12 MONTH LIMITED WARRANTY

UTStarcom Personal Communications (the Company) warrants to the original retail purchaser of this UTStarcom handheld portable cellular telephone, that should this product or any part thereof during normal consumer usage and conditions, be proven defective in material or workmanship that results in product failure within the first twelve (12) month period from the date of purchase, such defect(s) will be repaired or replaced (with new or rebuilt parts) at the Company's option, without charge for parts or labor directly related to the defect(s).

The antenna, keypad, display, rechargeable battery and battery charger, if included, are similarly warranted for twelve (12) months from date of purchase.

This Warranty extends only to consumers who purchase the product in the United States or Canada and it is not transferable or assignable.

This Warranty does not apply to:

- (a) Product subjected to abnormal use or conditions, accident, mishandling, neglect, unauthorized alteration, misuse, improper installation or repair or improper storage;
- (b) Product whose mechanical serial number or electronic serial number has been removed, altered or defaced.
- (c) Damage from exposure to moisture, humidity, excessive temperatures or extreme environmental conditions;
- (d) Damage resulting from connection to, or use of any accessory or other product

not approved or authorized by the Company;

- (e) Defects in appearance, cosmetic, decorative or structural items such as framing and non-operative parts;
- (f) Product damaged from external causes such as fire, flooding, dirt, sand, weather conditions, battery leakage, blown fuse, theft or improper usage of any electrical source.

The Company disclaims liability for removal or reinstallation of the product, for geographic coverage, for inadequate signal reception by the antenna or for communications range or operation of the cellular system as a whole.

When sending your wireless device to UTStarcom Personal Communications for repair or service, please note that any personal data or software stored on the device may be inadvertently erased or altered. Therefore, we strongly recommend you make a back up copy of all data and software contained on your device before submitting it for repair or service. This includes all contact lists, downloads (i.e. third-party software applications, ringtones, games and graphics) and any other data added to your device. In addition, if your wireless device utilizes a SIM or Multimedia card, please remove the card before submitting the device and store for later use when your device is returned, UTStarcom Personal Communications is not responsible for and does not guarantee restoration of any third-party software, personal information or memory data contained in, stored on, or integrated with any wireless device, whether under warranty or not, returned to UTStarcom Personal Communications for repair or service.

To obtain repairs or replacement within the terms of this Warranty, the product should be delivered with proof of Warranty coverage (e.g. dated bill of sale), the consumer's return address, daytime phone number and/or fax number and complete description of the problem, transportation prepaid, to the Company at the address shown below or to the place of purchase for repair or replacement processing. In addition, for reference to an authorized Warranty station in your area, you may telephone in the United States (800) 229-1235, and in Canada (800) 465-9672 (in Ontario call 416-695-3060).

THE EXTENT OF THE COMPANY'S LIABILITY UNDER THIS WARRANTY IS LIMITED TO THE REPAIR OR REPLACEMENT PROVIDED ABOVE AND, IN NO EVENT, SHALL THE COMPANY'S LIABILITY EXCEED THE PURCHASE PRICE PAID BY PURCHASER FOR THE PRODUCT.

ANY IMPLIED WARRANTIES, INCLUDING ANY IMPLIED WARRANTY OF MERCHANTABILITY OR FITNESS FOR A PARTICULAR PURPOSE, SHALL BE LIMITED TO THE DURATION OF THIS WRITTEN WARRANTY. ANY ACTION FOR BREACH OF ANY WARRANTY MUST BE BROUGHT WITHIN A PERIOD OF 18 MONTHS FROM DATE OF ORIGINAL PURCHASE. IN NO CASE SHALL THE COMPANY BE LIABLE FOR AN SPECIAL CONSEQUENTIAL OR INCIDENTAL DAMAGES FOR BREACH OF THIS OR ANY OTHER WARRANTY, EXPRESS OR IMPLIED, WHATSOEVER. THE COMPANY SHALL NOT BE LIABLE FOR THE DELAY IN RENDERING SERVICE UNDER THIS WARRANTY OR LOSS OF USE DURING THE TIME THE PRODUCT IS BEING REPAIRED OR REPLACED.

No person or representative is authorized to assume for the Company any liability other than expressed herein in connection with the sale of this product.

Some states or provinces do not allow limitations on how long an implied warranty lasts or the exclusion or limitation of incidental or consequential damage so the above limitation or exclusions may not apply to you. This Warranty gives you specific legal rights, and you may also have other rights, which vary from state to state or province to province.

**IN USA:** UTStarcom Personal Communications  
555 Wireless Blvd.  
Hauppauge, NY 11788  
(800) 229-1235

**IN CANADA:** UTStarcom Canada Company  
5535 Eglinton Avenue West  
Suite# 234  
Toronto, ON M9C 5K5  
(800) 465-9672

3-WAY CALLING 18

## A

ACCESSING THE MENU 14  
 ADJUSTING THE CALL VOLUME 19  
 ADJUSTING VOLUME 19  
 ALARM CLOCK 55  
 ANSWERING A CALL 18  
 ANSWERING CALLS 17  
 AVAILABLE OPTIONS DURING A CALL 20

## B

BATTERY HANDLING INFORMATION 12  
 BLUETOOTH 36

## C

CALCULATOR 53  
 CALENDAR 53  
 CALLER ID FUNCTION 20  
 CALLING A NUMBER FROM CONTACTS 19  
 CALL SETTINGS 45  
   ANSWER OPTIONS 45  
   AUTO RETRY 45  
   DTMF TONES 45  
   ONE TOUCH DIAL 45  
   TTY MODE 45  
   VOICE PRIVACY 45  
 CALL WAITING FUNCTION 19  
 CHARGING YOUR BATTERY 11  
 CONTACTS 28

CONTACT LIST 28  
 GROUPS 29  
 IN CASE OF EMERGENCY 31  
 MY NAME CARD 32  
 NEW CONTACT 28  
 SPEED DIALS 30

## D

DISPLAY INDICATORS 9  
 DISPLAY SETTINGS 39  
   BACKLIGHT 39  
   BANNER 39  
   CLOCK FORMAT 40  
   DIAL FONTS 40  
   DISPLAY THEMES 40  
   MAIN MENU 40  
   WALLPAPER 40

## E

ENTERING LETTERS, NUMBERS & SYMBOLS 25

## H

HANDSET DESCRIPTIONS 7

## I

INSIDE THE PACKAGE 6  
 INSTALL/REMOVE BATTERY 11

## K

KEYS DESCRIPTIONS 8

## M

MAKING A CALL 17  
 MAKING AN EMERGENCY CALL 20  
 MAKING AN INTERNATIONAL CALL 18  
 MEDIA CENTER 59  
   BROWSE & DOWNLOAD 67  
   EXTRAS 67  
   GAMES 65  
   PICTURES 64  
   MEDIA CENTER INFO 68  
   MOBILE WEB 66  
   MUSIC & TONES 61  
     GET NEW RINGTONES 61  
     MY RINGTONES 61  
     MY MUSIC 62  
     MY SOUNDS 62  
     SYNC MUSIC 63

## MEMORY 46

CARD MEMORY 46  
 PHONE MEMORY 46  
 SAVE OPTIONS 46

## MENU SUMMARY 15

## MESSAGING 69

CHAT 75  
 ERASE ALL 75  
 E-MAIL 75  
 DRAFTS 73  
 INBOX 72  
 MOBILE IM 74  
 NEW MESSAGE 70

SENT 72  
 SETTINGS 75  
   AUTO ERASE 75  
   AUTO SAVE 75  
   CALLBACK # 76  
   ENTRY MODE 75  
   PIC-VOICE AUTO RECEIVE 76  
   QUICK TEXT 76  
   SIGNATURE 76  
   TXT AUTO VIEW 76  
   VOICEMAIL# 76  
   VOICEMAIL 73

MISSED CALL NOTIFICATION 17  
 MY ACCOUNT 58

## N

NOTEPAD 56

## O

ONE-TOUCH/TWO-TOUCH DIALING 26

## P

PHONE INFO 46  
   ICON GLOSSARY 47  
   MY NUMBER 46  
   SOFTWARE UPDATE 47  
   SW / HW VERSION 46  
 PHONE SETTINGS 41  
   LANGUAGE 42  
   NAM SELECTION 44

SECURITY 43  
 SET SHORTCUTS 41  
 STANDALONE MODE 41  
 SYSTEM SELECT 44  
 VOICE COMMANDS 42

## R

RECENT CALLS 33  
   ALL 34  
   BLOCKED 35  
   DIALED 34  
   MISSED 33  
   RECEIVED 33  
   VIEW TIMERS 35

## S

SAFETY 78  
 SOUNDS SETTINGS 37  
   ALERT SOUNDS 37  
   CALL SOUNDS 37  
   DEVICE CONNECT 39  
   KEYPAD VOLUME 38  
   POWER ON/OFF 39  
   SERVICE ALERTS 38  
 SPEAKER PHONE MODE 20  
 STOP WATCH 57  
 STORING A PHONE NUMBER 24  
   ADDING A CONTACT IN IDLE MODE 24  
   ADDING A CONTACT THROUGH THE MENU 24

## T

TURNING THE PHONE ON/OFF 14

## U

USING AUTO KEYPAD LOCK FUNCTION 20  
 USING THE microSD CARD 60

## V

VIBRATE ON/OFF MODE 20  
 VOICE COMMANDS 48  
   CALL <NAME OR #> 48  
   CHECK <ITEM> 49  
   CONTACTS <NAME> 49  
   GO TO <SHORTCUT> 49  
   HELP 50  
   MY ACCOUNT 50  
   PLAY <PLAYLIST> 49  
   SEND <MSG TYPE> 48  
   VOICE COMMANDS SETTINGS 50

## W

WAIT/PAUSE FEATURE 18  
 WARRANTY 90  
 WORLD CLOCK 55

## **U.S.A.**

### ***U.S.FEDERAL COMMUNICATIONS COMMISSION*** **RADIO FREQUENCY INTERFERENCE STATEMENT**

#### **INFORMATION TO THE USER**

NOTE : This equipment has been tested and found to comply with the limits for a Class B digital device pursuant to Part 15 of the FCC Rules. These limits are designed to provide reasonable protection against harmful Interference in a residential installation This equipment generates, uses, and can radiate radio frequency energy and, if Not installed and used in accordance with the instructions, may cause harmful Interference to radio communications. However, there is no guarantee that interference will not occur in a particular Installation. If this equipment does cause harmful interference to radio or television reception, which can be determined by turning the equipment off and on, the user is encouraged to try to correct the interference by one or more of the following measures:

- \*- Reorient or relocate the receiving antenna.
- Increase the separation between the equipment and receiver.
- \*- Connect the equipment into an outlet of a circuit different from that to which the receiver is connected.
- \*- Consult the dealer or an experienced radio/TV technician for assistance.

Changes or modification not expressly approved by the party responsible for Compliance could void the user's authority to operate the equipment. Connecting of peripherals requires the use of grounded shielded signal cables.

## **FCC Compliance Information**

This device complies with Part 15 of FCC Rules.

Operation is subject to the following two conditions:

- (1) This device may not cause harmful interference, and
- (2) This device must accept any interference received.  
Including interference that may cause undesired operation.