

Contents

CHAPTER 1 --- BEFORE USING YOUR PHONE

PACKAGE INCLUDES	08
HANDSET DESCRIPTION	09
DISPLAY INDICATORS	11
USING THE BATTERY	12
INSTALLING THE SIM CARD	12
INSTALLING THE BATTERY	12
REMOVING THE BATTERY	13
CHARGING THE BATTERY	14
BATTERY LIFE (FOR NEW BATTERY)	15
IMPORTANT BATTERY INFORMATION	16
DOS	16
DON'TS	16

CHAPTER 2 --- BASIC OPERATION

TURNING THE PHONE ON AND OFF	18
TURNING THE PHONE ON	18
TURNING THE PHONE OFF	18
HOW TO USE THE MENU	19
MENU SUMMARY	20
BASIC FUNCTIONS	27
MAKING A CALL	27
HOW TO ANSWER CALLS	28
AUTO ANSWER	28
CALL ID FUNCTION	29

CALL WAITING FUNCTION	29
MISSED CALL DISPLAY	29
HOW TO ADJUST VOLUME	30
HOW TO STORE A PHONE NUMBER	31
HOW TO MAKE A CALL USING A STORED PHONE NUMBER	33
FUNCTION DURING A CALL	35
MUTE	35
TURN OFF TONES	35
HOLD CALL	35
SWITCH CALL	35
RELEASE ACTION	36
JOIN CALLS	36
TRANSFER CALL	36
RELEASE ALL	36

CHAPTER 3 --- MENU FUNCTION

CALL INFO	38
MISSED CALLS	38
CALL LIST	39
CALL COSTS	40
CALL TIMERS	43
SET NEXT CALL	45
OPTIONS	46
PHONE SETTINGS	47
PROFILES	47
NETWORKS	51

Contents

CALL OPTIONS	52
ACCEPT CALLS	52
FORWARD CALLS	54
RESTRICT CALLS	61
CALL WAITING	66
MINUTE MINDER	67
ANSWERING MODE.....	67
CLAM SHELL ANSWER.....	68
TURN AUTO REDIAL ON	68
DISPLAY	69
LANGUAGE	74
TIME AND DATE	75
SECURITY.....	77
PREF. SERVICE.....	79
MASTER RESET	80
SOUND.....	81
BELL VOLUME	81
SILENT	81
INCREASING BELL	82
BELL SIGNALS	82
ALARM SIGNAL	84
VIBRATING ALERT	84
MESSAGE ALERT	85
MY MELODIES	85
KEY SOUND	86
KEY VOLUME	86
PHONEBOOK	87
FIND	87
ADD NEW	89
COPY	91
GROUPS	93
OPTIONS	94
MEMORY STATUS	95
FIXED NUMBERS	96

MY NUMBERS	97
DELETE ALL	98
MESSAGES	99
CALL VOICE MAIL.....	99
INBOX	99
NEW SMS	101
UNSENT	102
TEMPLATE	104
SEND ITEM	106
OPTIONS	107
REFERENCE	113
ENTERING LETTERS, NUMBERS&CHARACTERS	113
STANDARD INPUT MODE (ABC MODE)	114
T9 ENGLISH MODE	115
SYMBOL MODE	117
123..MODE	118
E-MAIL.....	119
INBOX	119
NEW E-MAIL	121
SENT ITEMS	123
UNSENT	125
ARCHIVE	125
OPTIONS	125
ACCESSORIES	129
CALENDAR.....	129
ALARM CLOCK	131
TIMER	132
WORLD TIME	133
LUNAR CALENDER	134
VOICE MEMO.....	135
STOPWATCH	136
CALCULATOR	137

Contents

D-DAY SETUP	138
WAP BROWSER	140
MOBILE INTERNET	140
BOOKMARK	140
WAP PROFILE	141
ENTER ADDRESS	142
WAP SETTINGS	143

CHAPTER 4 --- SAFETY INFORMATION

SAFETY INFORMATION FOR WIRLESS HANDHELD PHONE	148
SAFETY INFORMATION FOR FCC RF EXPOSARE	154
SAR INFORMATION	155
FDA CONSMMER UPDATE	157

Memo

CHAPTER 1

BEFORE USING YOUR PHONE

- 1 : Package Includes
- 2 : Handset Description
- 3 : Handset Description
- 4 : Display Indicators
- 5 : Using the Battery
- 6 : Charging the Battery
- 7 : Important battery Information

1. Package Includes



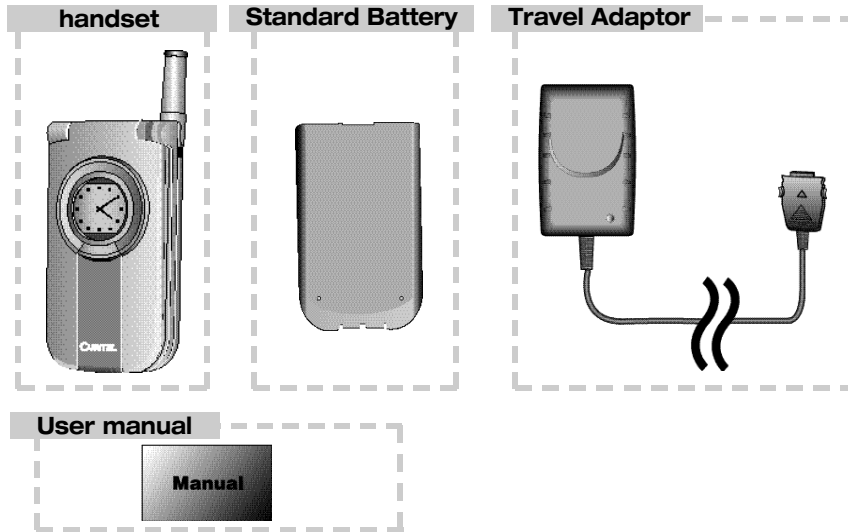



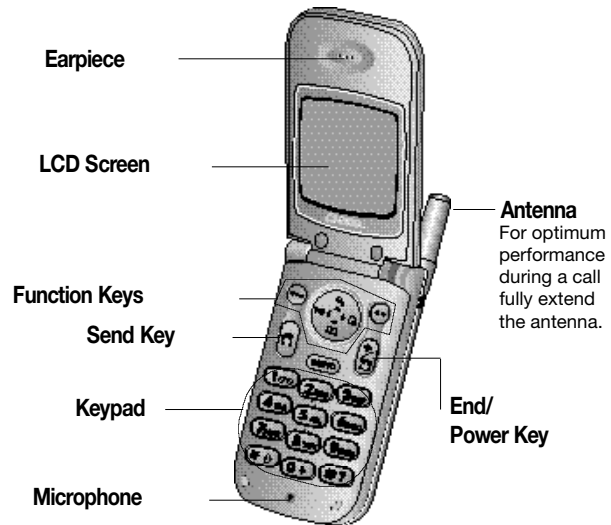

This package should include all items pictured below. If any are missing or different, immediately contact the retailer where you purchased the phone.



2. Handset Description



3. Handset Description

-  Press to make or receive a call.
-  Press to terminate a call or exit a current page, and turn the phone on/off.
-  Press to scroll through the items in the menu.
-  Press to access the menu or function as shown in the bottom line of the display.
-  Press to review a voice or text message, and return to the previous page.
-  Press to scroll through the items and adjust volume up/down.
-  Press to direct access the web browser.
-  Press to access the voice memo.

4. Display Indicators



Signal Strength

Current signal strength – the more lines the stronger signal.



No Service Indicator

Indicate that cannot receive a signal from the system.



Battery

Battery charging level – the more blocks the stronger the charge.



Call Forwarding

Indicate that call forwarding or restrict call is activated.



Missed Call

Indicate that a missed call in the call list.



Mute

Indicate that all audible signals are turned off.



Alarm

Indicates that the alarm is activated.



Message

New text or voice message.

Sub LCD Display Indicator

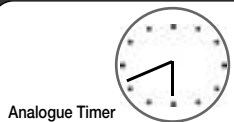

Analogue Timer

5. Using The Battery

1 INSTALLING THE SIM CARD

- 1 Insert the SIM card. Make sure the SIM card is placed under the silvery holders.

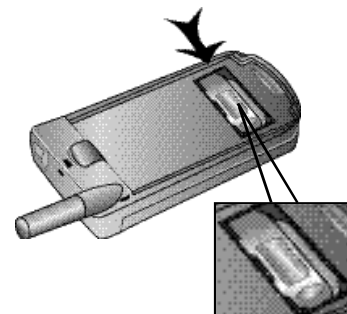

2 INSTALLING THE BATTERY

- 1 Place the battery on the back of the handset and slide into place.
- 2 Push the battery down until it locks into place.

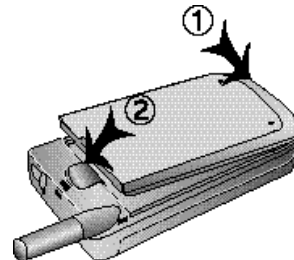

3 REMOVING THE BATTERY

① Pull down the release latch, lift up the battery and ② remove the battery from the handset.

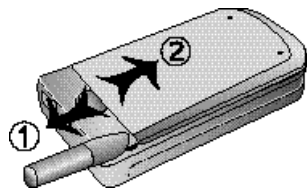

NOTE Securely place the battery to avoid slipping off during a call. To avoid losing any unsaved features and messages, turn off the phone before removing the battery.

① Connect the adaptor to the phone at the flash symbol. The flash symbol on the adaptor plug must face upwards.



6. Charging The Battery

The travel adaptor is used to recharge the phone using a simple plug in located at the bottom of the phone. The phone can still be used while it is plugged into the travel adaptor, but this will cause the phone to charge more slowly. To quickly charge the phone, turn the power Off.

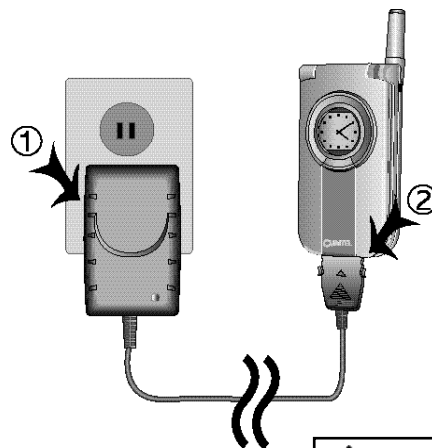

 Do not remove the battery during charging

LED of the charger will indicate charging status.

- Red indicates charging
- Green indicates charging is complete

BATTERY LIFE (FOR NEW BATTERY)

The operating time is subject to your handset usage and configuration.

	Standard Battery (760mAh)
Talk (min)	240 min
Stand by (hrs)	103 hrs

7. Important Battery Information

DOs

- Only use the battery and charger approved by the manufacturer.
- Only use the battery for its original purpose.
- Try to keep batteries in a temperature between 41°F and 95°F .
- If the battery is stored in temperatures above or below the recommended range, give it time to warm up or cool down before using.
- Completely drain the battery before recharging. It may take one to four days to completely drain.
- Store the discharged battery in a cool, dark, and dry place.
- Purchase a new battery when its operating time gradually decreases after fully charging.
- Properly dispose of the battery according to local laws.

DON'Ts

- Don't attempt to disassemble the battery – it is a sealed unit with no serviceable parts.
- Don't accidentally short circuit the battery by carrying it in your pocket or purse with other metallic objects such as coins, clips and pens. This may critically damage the battery.
- Don't leave the battery in hot or cold temps. Otherwise, it could significantly reduce the capacity and lifetime of the battery.
- Don't dispose of the battery into a fire.

- 1 : Turning the Phone On and Off
- 2 : How to Use the Menu
- 3 : Menu Summary
- 4 : Basic Functions
- 5 : How to Store a Phone Number
- 6 : How to Make a Call Using a
Stored Phone Number
- 7 : Functions During a Call

1. Turning The Phone On and Off

TURNING THE PHONE ON

Press and hold [], until the logo appears and the tone sounds.

- The phone is locked if “PHONE LOCKED ” is displayed on the screen. When “PHONE LOCKED ” is displayed, enter 4-digit lock code to unlock the phone.
- The default lock code is “0000”.









TURNING THE PHONE OFF

Press and hold [] until “ANIMATION ” is displayed.

- NOTE**
- Immediately change or recharge the battery when “Low Battery Warning Power Off” appears on the display. Memory may possibly be damaged if the phone turns off due to the battery completely draining.
 - **Turn the phone off before removing or replacing the battery. If the phone is on, data may be lost.**

2. How to Use The Menu

Your phone can be customized via the menu. Each function can be accessed by scrolling with the navigation keys or by pressing the number that corresponds with the menu item.

- 1 In the standby screen, press and hold [].
- 2 In the menu, use scroll keys to view the menu selections.
- 3 Use the following to scroll:
[], volume [ ], located on side of handset.
- 4 To go back to previous screen, press [] key.
To the exit menu, press [].
- 5 To go into submenu press the corresponding number.
- 6 [] and [] can be used while using the menu.

3. Menu Summary

1. Call Info

1. Missed Calls

2. Dialed Calls

3. Call Costs

- 1. Last Call
- 2. Total Cost
- 3. Clear Total Cost
- 4. Credit
- 5. Set Credit
- 6. Tariff
- 7. Set Tariff
- 8. Sent SMS
- 9. Clear Msg Count

4. Call Timers

- 1. Last Call
- 2. Total Time
- 3. Outgoing Time
- 4. Incoming Time
- 5. Clear Timers

5. Set Next Call

- 1. Show My Number
- 2. Hide My Number

6. Options

- 1. Clear Call History
- 2. Set Call History

2. Phone Settings

1. Profiles

- 1. Select Profile
- 2. Edit Profile
- 3. Reset Profiles

2. Networks

- 1. Select Network

3. Call Options

- 1. Accept Calls
- 2. Forward Calls
- 3. Restrict Calls
- 4. Call Waiting
- 5. Minute Minder
- 6. Answering Mode
- 7. Clam Shell Answer
- 8. Auto redial

4. Display

- 1. Light
- 2. User Greeting
- 3. Set Idle Screen
- 4. Set External Screen
- 5. Color Signal
- 6. Contrast
- 7. External Contrast

5. Language

- 1. Automatic
- 2. English
- 3. Espanol
- 4. Francais

6. Time and Date

- 1. Set Time
- 2. Time Format
- 3. Set Date
- 4. Date Format
- 5. Set Time Zone

7. Security

- 1. Card Lock
- 2. Phone Lock
- 3. Auto Keylock

8. Pref. Service

- 1. GPRS and GSM
- 2. GSM Only

9. Master Reset

3. Sound

1. Bell Volume

2. Turn Silent on

3. Increasing Bell

- 1. On
- 2. Off

4. Bell Signals

- 1. All Voice Calls
- 2. Personal Bells

5. Alarm Signal

- 1. Bell
- 2. Classic 1
- 3. Classic 2
- 4. Carol
- 5. Nature

6. Vibrating Alert

- 1. On
- 2. On if Silent
- 3. Bell after Vibration
- 4. Off

7. Message Alert

- 1. Silent
- 2. Click
- 3. Tone

8. My Melodies

- 1. My Melody 1
- 2. My Melody 2
- 3. My Melody 3
- 4. My Melody 4

9. Key Sound

- 1. Silent
- 2. Click
- 3. Tone

0. Key Volume

4. Phonebook

1. Find

- 1. Find by Name
- 2. Find by Position
- 3. Find by Group

2. Add New

- 1. Save to SIM
- 2. Save to Phone

3. Copy

- 1. Copy from Card
- 2. Copy to Card

4. Groups

5. Options

- 1. Fixed Dialling
- 2. Ask to Save

6. Memory Status

7. Fixed Numbers

8. My Numbers

- 1. Voice
- 2. Data

9. Delete All

5. Messages

- 1. Call Voice Mail
- 2. Inbox
- 3. Write Messages
- 4. Unsent Messages
- 5. Template
- 6. Sent Messages
- 7. Options

- 1. Message Alert
- 2. Voice Mail No.
- 3. Service Center
- 4. Area Information
- 5. Cell Information
- 6. Message Type
- 7. Validity Period
- 8. Reply Request
- 9. Status Request
- 10. Memory Request

6. E-mail

- 1. Inbox
- 2. New E-mail
- 3. Sent Items
- 4. Unsent
- 5. Archive
- 6. Options

- 1. E-mail Profile
- 2. E-mail Settings

6. Accessories

- 1. Calendar
- 2. Alarm Clock
- 3. Timer
- 4. World Time
- 5. Lunar Calendar
- 6. Voice Memo
- 7. Stopwatch
- 8. Calculator
- 9. D-Day Setup

- 1. View today
- 2. View all tasks
- 3. View month
- 4. Add task?
- 5. Delete all

- 1. Madrid
- 2. London
- 3. Paris
- 4. Rome
- 5. Berlin
- 6. Athens
- 7. Cairo
- 8. Belgrade
- 9. Teheran
- 0. Karachi ...

- 1. Solar To Lunar
- 2. Lunar To Solar
- 3. Chinese New Year
- 4. Month in Lunar

- 1. Record
- 2. Memo list
- 3. Erase all

- 1. View List
- 2. Input New Item

7. WAP Browser

- 1. Mobile Internet
- 2. Bookmarks
- 3. WAP Profile
- 4. Enter Address
- 5. Resume
- 6. WAP Settings

- 1. WAP Profile 1
- 2. WAP Profile 2
- 3. WAP Profile 3



4. Basic Function

1 : MAKING A CALL

- 1 Enter a phone number.



To modify the phone number you have entered :

- Press [] to erase one digit at a time
- Press and hold [] or [] to erase the entire number and input correct number again.

- 2 Press [].

- 3 Press [] to end the call.

2 : HOW TO ANSWER CALLS

Press YES to answer a call.





- 1 When phone rings or LED blinks press [] or any key except side keys.

- 2 To end the call, press [].



3 : AUTO ANSWER

When you received the incoming call, you can connect the caller automatically.

- 1 This function allows an incoming call to be connected to calling party automatically.
Press [], [], [], [].

4 : CALL ID FUNCTION



Displays the caller's name and phone number, if available, in the phone book.

- When there is an incoming call, the caller's phone number is displayed on the screen.

5 : CALL WAITING FUNCTION

Notifies of another incoming call when you are on the phone by making a beep sound and displays the caller's phone number on the screen.

- This function notifies you there is an incoming call when you are on the phone.

- To answer the call, press [] when you hear the beep.
- To switch back to the first caller, press [] again.

6 : MISSED CALL DISPLAY

- Displays the number of missed calls and the time the call was missed.
 - The message will be cleared when you press the [] key.

7 : HOW TO ADJUST VOLUME

Adjust the volume with the volume buttons on the side of the handset or through the menu entry.

- 1 Adjust volume by using the volume control keys during the following operation.



- Idle During a Call : Earpiece volume adjustment.
- Status : Bell volume adjustment.
- Call status in hands-free : Hands-free volume adjustment.



- 2 Press [] when the phone rings and it will mute the ringer.

5. How to Store a Phone Number

You can store up to 100 frequently used phone numbers in memory.

SAVING IN MENU

Press [] [] [].
Then enter the phone number.

- 1 Enter the phone number (more than 3 digits) you want to store and press [].
- 2 Select Save To Sim/Save To Phone type then press [].
- 3 The next available empty memory Location number is displayed.
Press [] to “OK”.
If there is a desired memory location number, enter the number.

If the “[Name/Number] Overwrite?” message appears after entering the memory location number, it means there is another stored phone number in that location already.

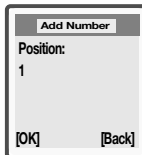

- 4 To enter a name, use [] and [], select a name entry, edit or enter a name, and press [].

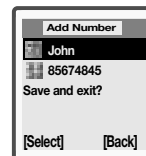



- 5 To save any change, use [] and [], select an entry for save and exit, and press [].

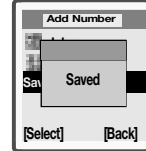

You can save phone numbers in phonebook menu. refer to 4. Phone Book 2) Add Number



SAVING IN IDLE

- 1 Enter a phone number which you want to save.
- 2 Press [] to save it.
- 3 Press [] to save it in phone book.
- 4 Next steps are same procedure suchlike “SAVING IN MENU”

6. How to Make a Call Using a Stored Phone Number.



1. SELECT FROM SAVED NAME

A call can also be made by pressing its first alphabet in the phone book.

- 1 Press long first alphabet keypad of name saved on phone book.
- 2 Select the one from saved list.
- 3 Press [] to start a call.

2. SELECT FROM SAVED LOCATION

A call can also be made by pressing its location number and [].

- 1 Press the corresponding memory number and press [].
- 2 Select the one from saved list.
- 3 Press [] to start a call.

7. Functions During a Call

1 : MUTE

The caller cannot hear you and any sound from your side, while you can hear his or her voice.

Press and hold [].



1 : Turn off Tones

During a call, you can turn off tones.

Press [], then [] “Turn off Tones”.



2 : Hold Call

Displays your phone number during a call and automatically returns to the receiving mode in five minutes.

Press [], then [] “Hold Call”.

3 : Switch Call

When connected the two calls, you can switch between the two calls.

Press [], then [] “Switch Call”.



4 : Release Action

When the connected the two calls, you can disconnect the one calls.

Press [], then [] “Release Action”.

5 : Join Calls

Call the next person you wish to include in the conference group.

Press [], then [] “Join Calls”.



6 : Transfer Call

When connected the two calls, the two calls are now connected to each other.

Press [], then [] “Transfer Call”.

7 : Release All

You can disconnect the all calls.

Press [], then [] “Release All”.

- 1 : Call Informations
- 2 : Phone Settings
- 3 : Sound
- 4 : Phonebook
- 5 : Messages
- 6 : E-Mail
- 7 : Accessories
- 8 : WAP Browser

1. Call Informations

1) Missed Calls



If you have missed a call, the message “missed call 1” appears in standby mode (The number indicates the number of missed calls)

1 Press [] [] [].

2 Press [] to view the detail of a missed call when the number is highlighted.

NOTE Details include time, and phone number of missed calls.

3 Use the scroll key to scroll through the last 10 missed calls and to select a number.

4 Press [] [] to dial a phone number of the missed call list.

2) Call Lists

You see the call number list of mobile originated and terminated calls.

1 Press [] [] [].

2 The detail information of a selected call will be displayed when the number is highlighted.

NOTE Details include time, and phone number of received calls.

3 Use the scroll key to scroll through the last 10 received call and to select a number.

4 Press [] [] to dial the phone number of the selected call.

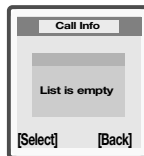

3) Call Costs

You can check the cost of your Last Call and the Total cost of your calls.

1: LAST CALL

Press [] [] [] [] to view the cost of last call "Last Call #.#" is to be displayed.

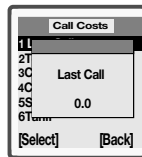

2: TOTAL COST

Press [] [] [] [] to view a total cost. "Total Cost #.#" is to be displayed.

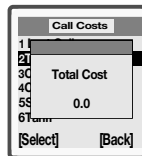

3: CLEAR TOTAL COST

Press [] [] [] [] to clear the total cost. PIN2 is required to clear total cost.

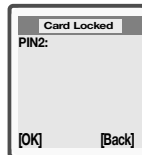

4 : CREDIT

Press [] [] [] [] to view a credit.
Credit is to be displayed.

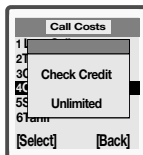

5 : SET CREDIT

Press [] [] [] [] to set the credit.
PIN2 is required to set the credit.

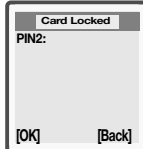

6 : TARIFF

Press [] [] [] [] to view a tariff
"Tariff #.#" is to be displayed.

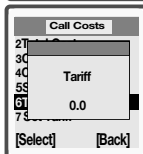

7 : SET TARIFF

Press [] [] [] [] to set the tariff.

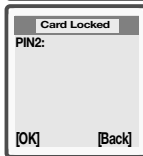

8 : SENT SMS

Press [] [] [] [] to view the number
of sent SMS.

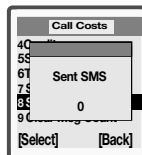

9 : CLEAR MSG COUNT

1 Press [] [] [] [] to clear up the
number of sent SMS.

2 Press [] to reset it when a message
"Sent SMS reset?" appears on the screen.

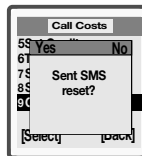

4) Call Timers

You can check the duration of your Last Call, Outgoing Calls, Incoming calls and the Total Time.

1: LAST CALL

Press [] [] [] [] to check talk time of last call
“Last call ##:##” is to be displayed.

2: TOTAL SENT

Press [] [] [] [] to check talk time of all calls
“Total Sent #:##:##” is to be displayed.

3: OUTGOING CALLS

Press [] [] [] [] to check talk time of outgoing calls
“Out going Calls #:##:##” is to be displayed.

4: INCOMING CALLS

Press [] [] [] [] to check talk time of incoming calls
“Incoming Calls #:##:##” is to be displayed.

5: RESET TIMERS

Press [] [] [] [] to clear timers.
You are to select one of the timers.

1: TOTAL CALL

1 : Press [] and you will see
“Total Calls Clear?” displayed on the screen.

2 : Press [] to clear up total talk time.

2: OUTGOING CALLS

1 : Press [] and you will see
“Out going Calls Clear?” displayed on the screen.

2 : Press [] to clear up talk time of out going calls.

3: INCOMING CALLS

1 : Press [] and you will see
“Incoming Calls Clear?” displayed on the screen.

2 : Press [] to clear up talk time of incoming calls.

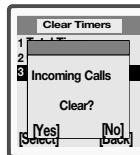
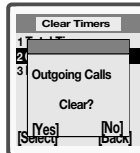
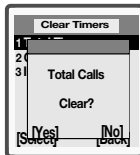

5) Set Next Call

1: SHOW MY NUMBER

Press [] [] [] [] to show your phone number.

2: HIDE MY NUMBER

Press [] [] [] [] to hide your phone number.

6) Options

1: CLEAR CALL LIST

1 Press [] [] [] [] to delete a list of 10 recently dialed calls.

2 Press [] to proceed with it when a message “Call List Clear?” appears.

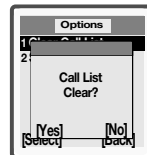

2: SET CALL HISTORY

Press [] [] [] [] to Check into either of ENABLE or DISABLE and press [].

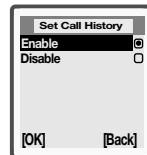

2. Phone Settings

1) Profiles

Enables you to set a profile where you have a totally different set of options, select a certain profile when necessary to use your phone with more convenience and carefulness.

1 : SELECT PROFILE

Press [] [] [] [] to select a profile
Check into one of the following profiles and press [] to save it.

- Normal/Meeting/Outdoors/Hands-free/Home.

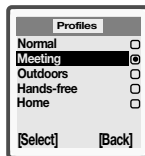

2 : EDIT PROFILE

1 : BELL VOLUME

- 1 : Press [] [] [] [] [] to adjust a ringer volume.
- 2 : Turn up and down with the navigation key.
You are to control the volume in 5 levels.

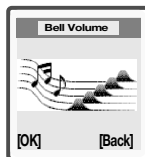

2 : TURN SILENT ON / OFF

- 1 : Press [] [] [] [] [] to mute or activate a key tone.
- 2 : Check into either of ON or OFF.
- 3 : Press [] to save it.



3 : INCREASING BELL

- 1 : Press [] [] [] [] [] to activate or deactivate an increasing ringer.
- 2 : Check into either of ON or OFF.
- 3 : Press [] to save it.

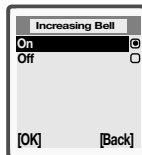

4 : LIGHT

1 : Press [] [] [] [] [] to control backlight.

2 : Check into one of the following options and press [].

- ON : Keep back light on
- OFF : Keep back light off
- AUTO ON/OFF : Control back light automatically
- You are to choose one of the options (Rainbow/Colorred/Colorgreen/Color blue/Color yellow/Violet /Blue Green/White), once you check into either ON or AUTO ON/OFF and press [] to save it.

5 : VIBRATING ALERT

1 : Press [] [] [] [] [] to set vibrating alert
Check into one of the following options and press [] to save it.

- On : Activate vibrating alert
- On if silent : Activate vibrating alert when a ringer is mute.
- Bell after Vibration : A ringer sounds after vibration.
- Off : Deactivate vibrating alert.

6 : PROFILE NAME

1 : Press [] [] [] [] [] to check out a profile name and edit it.

2 : Press [] to maintain the profile name or Edit the existent profile name and press [].

7 : AUTO ACTIVATION

1 : Press [] [] [] [] [] to set Auto Activation.

2 : Check into either of ON or OFF and press [].

8 : ACCESSORIES

1 : Press [] [] [] [] [] to add an accessory.

2 : Select “Add accessory?” and press [] to view a kind of accessories.

3 : Select one with the navigation key and press [].

4 : Press [] to add the accessory when you see
“Associate accessory with current profile? Associate?”

3 : RESET PROFILES

1 Press [] [] [] [] to reset all profiles.

2 Press [] to proceed with it.

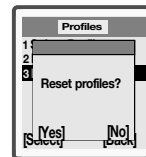

2) Networks

When you turn on the phone, it automatically searches for your home network. If this is not within range, you may use another network provided your network operator has an agreement that allows you to do so. This is called roaming.

1: SELECT NETWORK

1 Press [] [] [] [] to select a network available.

2 Phone will search for an available network.

3) Call Options

1 Accept Calls

Decides whether you are to accept calls or not.

1: ACCEPT OPTIONS

Decides to accept whose calls.

1 Press [] [] [] [] [].

2 Check into one of the following items and press [] to save it.

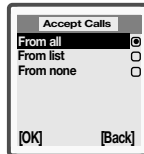

- From all : Accept all calls.
- From list : Accept only calls from the list of accepted persons.
You will see "From list " displayed on the screen.
- From none : Reject all calls.

2: ACCEPTED LIST

Makes up a list of persons you are to accept call from.

1 Press [] [] [] [] [].

2 Move to “Add new?” with the navigation key and press [].

3 Select a phone book entry and press [].



2 Forward Calls

This network service lets you forward incoming calls to another phone number

1: ALL VOICE CALLS

Forward all voice calls without ringing.

1 Press [] [] [] [] [].

2 You are to choose one from the following items.

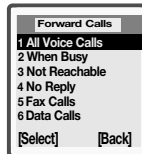

1: ACTIVATE

Forward all voice calls to a specific phone number.

- Press [] and choose Phone Book or Voice Mail or Other number.

If you select Phone Book, all calls are forwarded to a phone number in the phone book.

If you select Voice mail, all calls are forwarded to your voice mailbox.

If you select Other number, enter the phone number to which you want to forward calls.

2: CANCEL

- Press [] not to forward any call.

3: GET STATUS

- Press [] to view the status of all voice calls.

2 : WHEN BUSY

Forward calls if you are already on the phone.

1 Press [] [] [] [] [].

2 You are to choose one from the following items.

1 : ACTIVATE

Forward calls to a specific phone number when the line is busy.

- Press [] and enter a phone number then, press [].

2 : CANCEL

- Press [] not to forward any call.

3 : GET STATUS

- Press [] to view its status.

3 : NOT REACHABLE

Forward calls if you phone is turned off or if you are unreachable.

1 Press [] [] [] [] [].

2 You are to choose one from the following items.

1 : ACTIVATE

Forward calls to a specific phone number when the phone is out of service area.

- Press [] and enter a phone number then, press [].

2 : CANCEL

- Press [] not to forward any call.

3 : GET STATUS

- Press [] to view its status.

4 : NO REPLY

Forward calls that you do not answer within a specified time limit.

1 Press [] [] [] [] [].

2 You are to choose one from the following items.

1 : ACTIVATE

Forward calls to a specific phone number when no one answers a call.

- Press [] and enter a phone number then, press [].

2 : CANCEL

- Press [] not to forward any call.

3 : GET STATUS

- Press [] to view its status.

5 : FAX CALLS

Forward calls that you received fax calls.

1 Press [] [] [] [] [].

2 You are to choose one from the following items.

1 : ACTIVATE

Forward calls to a specific phone number when you receive fax calls.

- Press [] and enter a phone number then, press [].

2 : CANCEL

- Press [] not to forward any call.

3 : GET STATUS

- Press [] to view its status.

6 : DATA CALLS

Forward calls that you received data calls.

1 Press [] [] [] [] [].

2 You are to choose one from the following items.

1 : ACTIVATE

Forward calls to a specific phone number when you receive data calls.

- Press [] and enter a phone number then, press [].

2 : CANCEL

- Press [] not to forward any call.

3 : GET STATUS

- Press [] to view its status.

7 : CHECK ALL

Cancel all call forwarding.

Press [] [] [] [] [] to check all.

3 Restrict Calls

The Restrict Calls service allows you to restrict certain types of calls being made and received.

1 : ALL OUTGOING

1 Press [] [] [] [] [].

2 You are to choose one from the following items.

1 : ACTIVATE

Restrict all outgoing calls.

- Press [] and enter a password then, press [].

2 : CANCEL

- Press [] and enter a password not to restrict any outgoing call.

3 : GET STATUS

- Press [] to view its status.

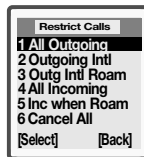

2 : OUTGOING INTERNATIONAL

1 Press [] [] [] [] [].

2 You are to choose one from the following items.

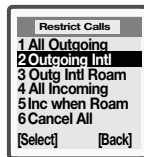

1 : ACTIVATE

Restrict outgoing international calls.

- Press [] and enter a password then, press [].

2 : CANCEL

- Press [] and enter a password not to restrict any outgoing international call.

3 : GET STATUS

- Press [] to view its status.

3 : OUTGOING INTERNATIONAL ROAM

1 Press [] [] [] [] [].

2 You are to choose one from the following items.

1 : ACTIVATE

Restrict outgoing international roaming calls.

- Press [] and enter a password then, press [].

|| 2 : CANCEL

- Press [] and enter a password not to restrict any outgoing international roaming calls.

|| 3 : GET STATUS

- Press [] to view its status.



○ 4 : ALL INCOMING

1 Press [] || [] || [] || [] || [].

2 You are to choose one from the following items.

|| 1 : ACTIVATE

Restrict all incoming calls.

- Press [] and enter a password then, press [].

|| 2 : CANCEL

- Press [] and enter a password not to restrict any incoming calls.

|| 3 : GET STATUS

- Press [] to view its status.



○ 5 : INCOMING WHEN ROAM

1 Press [] || [] || [] || [] || [].

2 You are to choose one from the following items.

|| 1 : ACTIVATE

Restrict incoming when roaming calls.

- Press [] and enter a password then, press [].







|| 2 : CANCEL

- Press [] and enter a password not to restrict incoming when roaming calls.







|| 3 : GET STATUS

- Press [] to view its status.

6: CANCEL ALL





- 1 Press [] [] [] [] [].
- 2 Enter a password and press [] to cancel any set restrictions.

7: CHANGE PASSWORD

- 1 Press [] [] [] [] [].
- 2 Enter an old password and a new password then, repeat the new password.
- 3 Press [] to change a password.

4 Call Waiting

Allows you to answer another incoming call when you already have one.

- 1 Press [] [] [] [].
- 2 You are to choose one from the following items.

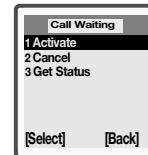

1 : ACTIVATE

Enables a feature of call waiting.

- Press [].

2 : CANCEL

- Press [].

3 : GET STATUS

- Press [].

5 Minute Minder

If you turn on the minute minder, you hear a beep once every minute during a call.

1 Press [] [] [] [].

2 Check into On or Off with the navigation key and press [] to confirm it.



6 Answering Mode

When using a portable handsfree unit, you can choose to answer a call by pressing any key (except the NO key) or set the phone to answer the call automatically.

1 Press [] [] [] [].

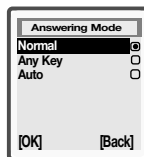

7 Clam Shell Answer

When clam shell is opened you can answer the call.

1 Press [] [] [] [].

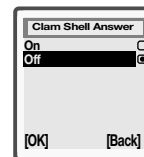

8 Turn Auto Redial On

The phone is automatically redialed the number you're trying to call up.

1 Press [] [] [] [].

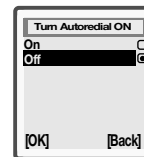



4) Display

1: LIGHT

The display light can be set to on, off, auto on/off. In automatic mode, the display light is turned off a few seconds after you press the last key.

1 Press [] [] [] [] to adjust back light.

2 Check into one of the following options and press [] .

- ON : Keep backlight on
- OFF : Keep backlight off
- AUTO ON/OFF : Control selected backlight automatically.
You are to choose one of the options (Rainbow/Color red /Color green/Color blue/Color yellow/Violet/Blue Green/White), once you check into either On or Auto On/Off.
And press [] to save it.

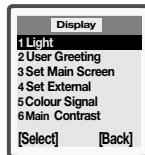



2: USER GREETING

Displays User Greeting as you set when you turn on the phone.

1 Press [] [] [] [] to set User Greeting.

2 Check into one of the following items and press [] .

STANDARD

- Press [] to preview standard user greeting or [] to activate or deactivate animation sound.
- Press [] .

CUSTOM

- Custom – Customize user greeting and press []

OFF

- Off – Don't display user greeting.

3: SET IDLE SCREEN

Set main idle screen out of 5' screen modes.

1 Press [] [] [] [] to set screen for Idle Mode.

2 Check into one of the following items and press [] .

- Animation : Display animation on idle mode.
- World Map : Display World map on idle mode.
- Digital Time : Display Digital Time on idle mode.
- Day & Greeting : Display a user text on idle mode.
- Lunar & Greeting : Display lunar year and a user text on idle mode





4 : SET EXTERNAL SCREEN

1 Press [] [] [] [] to set screen for external LCD.



2 Check into one of the following items and press [].

- Analog Watch : Display analog watch.
- Digital Watch : Display digital time.
- Curitel Watch : Display digital time and phone information.
- Greeting Watch : Display network name on the external LCD.



5 : COLOR SIGNAL

1 Press [] [] [] [] to set colour signal for a specific phone number.





2 Move to “Add new?” key and press [].

- Enter a phone number and press [].
- Check into one of the options (Rainbow/Color red/Color green/Color blue/Color yellow/Violet/Blue Green/White)
- Press [].





3 Select a phone number with the navigation key and press [].

- Press [] to change color and check into one color.
- Press [] to delete color signal designated for the phone number. You will see “Deleted” displayed on the screen.





6: CONTRAST

- 1 Press [] [] [] [] to adjust contrast for better view.
- 2 Adjust it in 7 levels with the navigation key.
Press [] to save it.

7: EXTERNAL CONTRAST

- 1 Press [] [] [] [] to adjust contrast for better view.
- 2 Adjust it in 7 levels with the navigation key.
Press [] to save it.

5) Language

- 1 Press [] [] [] to decide what language is to be used for display.
(Automatic/English/Espanol/Francais)
- 2 Check into one of the languages and press [] to save it.



6) Time and Date

The time is always displayed in standby mode.

1: SET TIME

1 Press [] [] [] [] to set time.

2 Enter hour and minute digit by digit.

- To change hour and minute, press [] to go back.

3 Press [] to save it.

2: TIME FORMAT

1 Press [] [] [] [] to set time format.

2 Check into either 24 hours or am/pm with the navigation key and press [] to save it.

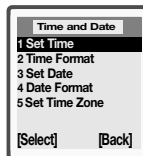

3: SET DATE

1 Press [] [] [] [] to set date.

2 Enter day, month and year.

- To change day, month and year, Press [] to go back.

3 Press [] to save it.

4: DATE FORMAT

1 Press [] [] [] [] to set date format.

2 Check into one of the formats with the navigation key and press [] to save it.

5: SET TIME ZONE

1 Press [] [] [] [] to set date format.

7) Security

1: CARD LOCK

1 Press [] [] [] [] to set card lock.

2 You are to see the following two items.

- Protection : Press [] and check into "ON" then, press [] to set up protection.
- Change PIN2 : Enter old PIN2, press [].
Enter new PIN2, press [].
Enter the new PIN2 again and press [] to save it.

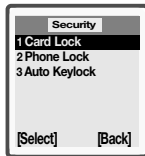

2: PHONE LOCK

1 Press [] [] [] [] to set Phone Lock.

2 You are to see the following two items.

- Protection : Press [] and check into "ON" then, Press [] to set up protection.
- Change Code : Enter old code, press [], enter new code, press [].
Enter the new code again and press [] to save it.

3: AUTO KEYLOCK

Prevents accidental key press with this feature on.

1 Press [] [] [] [] to set Auto Key Lock.

2 Check into "ON" or "OFF" to activate or deactivate Auto Key Lock.

8) Pref. Service

You can select the GPRS and GSM service or GSM only service.

1 Press [] [] [] to select Pref. service.

9) Master Reset

Resets Phone lock code.

PHONE LOCK CODE

1 Press [] [] [] to reset Phone.

2 Enter Phone Lock Code.

3 Press [] .

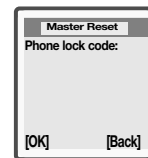

3. Sound

1) Bell Volume

The bell volume can be set to 5 levels.
You can also turn the bell volume off(0)

- 1 Press [] [] [] to adjust bell volume.
- 2 Turn up and down with the navigation key.
You are to control the volume in 5 levels or mute the ringer.
- 3 Press [] to save it.

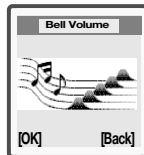

2) Silent

- 1 Press [] [] [] to mute or activate sound and tone.
- 2 Check into "On" or "Off", press [] to save it.

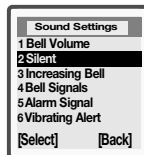

3) Increasing Bell

You can choose a ring signal that rises in steps from the lowest volume to the highest.

- 1 Press [] [] [] to activate or deactivate an increasing bell.
- 2 Check into "ON" or "OFF"
Press [] to save it.

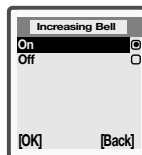

4) Bell Signals

You can choose a ring signal from a list of different sounds and melodies.

- 1 Press [] [] [] to assign a melody to a phone number.
- 2 You are to see the two items displayed as below.

ALL VOICE CALLS

- 1 Press [] to allow the same melody or bell to all incoming calls.
- 2 Check into one of the following items with the navigation key and press [] to go to submenu. (Bell/Classic1/Classic2/Carol/Nature)



3 Select one then, press [] to save it.



PERSONAL BELLS

If your subscription includes the Calling Line Identification service, you can assign a personal ring signal to up to ten callers. If the last seven digits of a caller's number correspond to a number you have specified, then that caller's ring signal is used.

1 Press [] to assign a melody to a phone number.

2 Move to "Add new?" with the navigation key and press [] to add a phone number with a specific melody or bell.

3 Enter a phone number and press [].
Check into one of the following items with the navigation key and press [] to go to submenu.(Bell/Classic1/Classic2/Carol/Nature)
Select one then, press [] to save it.

4 To Edit or delete an assigned melody or bell to a phone number, Move to the phone number and press [].
Press [] to edit it or [] to delete it.

5) Alarm Signal

1 Press [] [] [] to select a melody or bell for alarm signal.

2 Check into one of the following items with the navigation key and press [] to go to submenu. (Bell/Classic1/Classic2/Carol/Nature)

3 Select one then, press [] to save it.

6) Vibrating Alert

You can choose to be notified of an incoming call by the buzzing of the Vibrating alert. You can set the phone's Vibrating alert to one of the following:

- On (keep vibrating alert on)
- On if Silent (on when the ring volume is turned off or when you set the phone to silent)
- Bell after vibration (ring a sound after vibrating alert)
- Off (keep vibrating alert off)

1 Press [] [] [] to set Vibrating Alert .

2 Check into one of the following options and press [] to save it.

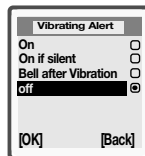

7) Message Alert

Decide that user can what alert you are to be given to an incoming message.

1 Press [] [] [] to set Message Alert.

2 You are to select one of the following items with the navigation key.

- Silent / Click / Tone

3 Press [] to save it.

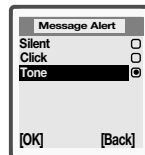

8) My Melodies

1 Press [] [] [] to set My Melodies.

- My Melody 1/My Melody 2/My Melody 3/My Melody 4

9) Key Sound

You can set the key sound to silent, click or tone.

1 Press [] [] [] to set Key Sound.

2 You are to select one of the following items with the navigation key.

- Silent / Click / Tone

3 Press [] to save it.

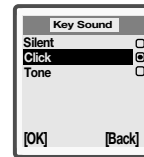

10) Key Volume

1 Press [] [] [] for key volume.

- If the warning alarm sounds because of low battery, the sound will not be heard even if the user presses the button.

2 Select the volume level by using the navigation keys.

- [] scroll up to increase volume.
- [] scroll down to lower volume or to set to silent.



3 Press [] to save it.

4. Phonebook

1) Find



To search phonebook number.

1 Press [] [] [].

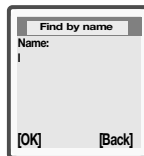
2 Select the sort order to find.
Press [] to find by name.
Press [] to find by position.
Press [] to find by group.







3 Find by name

1. Enter the name which is looking for. Press [].
2. Select a name and press [] then calling out.

- If the selected name is saved the number in handset.
You can use the Navigation right / left key to select multi number and call out.
(Home, Office, Mobile, Fax)

3. Select the name which is looking for and press [].
You can Delet / Edit / SMS / Copy in submenu.

4 Find by position

1. Select a mode SIM or Phone to find.
Press [] to find from SIM.
Press [] to find from phone.
2. Enter a position which you look for, then press [].
3. Select a position, then you can call out.
4. You can Delet / Edit / SMS / Copy in submenu, Select a position and press [].

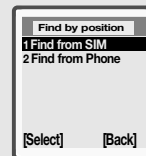

5 Find by group

1. Select a group.
2. In group, press a member and call out.
3. If you want to Delet / Edit / SMS / Copy, Select a member and press [].

2) Add New

Adds a phone number to the phonebook.

1 Press [] [] [].



2 SIM or Phone



1. Save to SIM : Press [] [] [] [].



2. Save to Phone : Press [] [] [] [].

3 Enter a position to save, press [].

4 Save to SIM -You are to save name and number.





1. To enter a name, use [] and [], select a name entry, edit or enter a name, and press [].

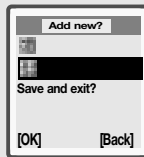
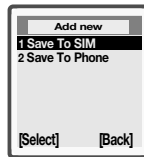



2. To enter a number, use [] and [], select a number entry, edit or enter a number, and press [].





3. To save any change, use [] and [], select an entry for save and exit, and press [].





5 Save to Phone - You are to save name, phone numbers for mobile, office and fax, e-mail, memo, group etc.

1. To enter name, e-mail and memo, use [] and [], press [], edit or enter each one, and press [].

2. To enter home, mobile, office and fax, use [] and [], press [], edit or enter each one, and press [].

3. To select a group, use [] and [], move to an entry for group, press [], select a group from the list, and press [].

4. To save any change, use [] and [], select an entry for save and press [].

3) Copy

To copy phonebook number.

1 Press [] [] [].

2 Select a mode for copy.

Press [] to copy from card.

Press [] to copy from phone.

3 Copy from card

Select a copy mode either one by one or all

Press [] to copy one by one from card.

Press [] to copy all from card.

1. One by One

Select a record and press [] and select default number to be saved.

2. Copy all

You will see "Entries saved in card memory will be copied. Copy from card?"

Press [] and you will see "Copying please wait",
"Phone book entries copied : ##".

4 Copy to card

Select a copy mode either one by one or all

Press [] to copy one by one from phone.

Press [] to copy all from phone.

1. One by One

Use Navigation right / left key to find a record to copy in number.

2. Copy all

You will see "Entries saved in phone memory will be copied. Copy from card?"

Press [] and you will see "Copying please wait",
"Phone book entries copied : ##".

4) Groups

Groups phonebook entries under a name in order to organize them in an orderly manner.

1 Press [] [] [].

2 Move to an existing group with the navigation key and press []. You can edit group name.



- Delete
Press [] and you will see “[group name] Delete?”
Press [] to delete a group.

3 Select “Add new?” and press [] to make a group.

- Enter the group name and press [].
- You can make groups to Ten.

5) Options

Shows various optional items for you to decide on.

1. FIXED DIALLING

Press [] [] [] [].
If you have FDN Card.
You can make FDN enable or unable.
You must enter your PIN2.

- FDN (Fixed Dialling Number)

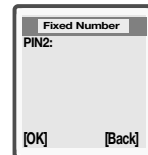

2. ASK TO SAVE

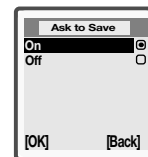

If ask to save is on, you are asked if you want to save any called or answered number that is not already saved in your phone book.

Press [] [] [] [].



6) Memory Status

Displays the status of memories, Card, Phone and E-mail.

1 Press [] [] [] and the memory status is to be displayed as follows.

- Status 3 (250)
- Status 0 (100)

Card memory depends on SIM card.

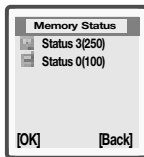

2 Press [] to go back to the previous menu.

7) Fixed Numbers

If you have FDN Card.

You can only call phone numbers saved in phonebook.
You must enter your PIN2.

1 Press [] [] [].

2 Press [] to save a new number.

3 Enter a PIN2 and press [].

4 Enter a phone number and press [].

5 Enter a name, select the memory in which you want the number to be saved.

6 Press [] to save it.

- If your card isn't FDN, this menu is disable.

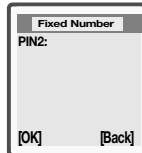
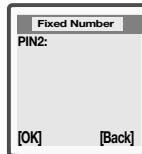

8) My Numbers



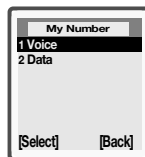

Displays your phone number.

Press [] [] [] [] and select and enter the phone / data number and press [] to save it.



9) Delete All

Deletes all the data in the phone book memory.

- 1 Press [] [] [] and you will see "Delete all in phone memory?"
- 2 Press [] to confirm it or [] to go back to the previous menu.

5. Messages

1) Call Voice Mail

This menu provides you with a quick way of accessing your voice mailbox. before using this feature, you must enter the voice mail No in optionsmenu. Store or change the server number obtained from your service provider. You can listen to your messages.

- Press [] [] [] and place a call to your Voice Mailbox to check a voicemail.

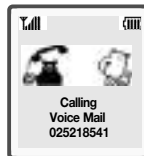

2) Inbox

When the icon appears, you have received new text messages.

- Press [] [] [] and you will see a list of inbox message. Select a message with the navigation key and press [] to read.

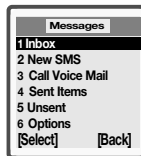

1. DELETE

- Delete the received SMS. Press [] and you will see "Deleted".

2. REPLY

- Reply to the SMS sender. Press [] then, select a reply message type. Edit new or with the received or templates.

3. FORWARD

- Forward the received SMS to someone. Press [] then, edit the message or press [].

4. SAVE

- Save the received SMS. Press [].

5. CALL



- Call the SMS sender. Press [] and you will call.

6. READ NEXT



- Read the next received SMS. Press [] and you will read the next SMS.

3) Write Messages

Before using this feature, you must enter the service centre in options menu. Store or change the server number obtained from your service provider.



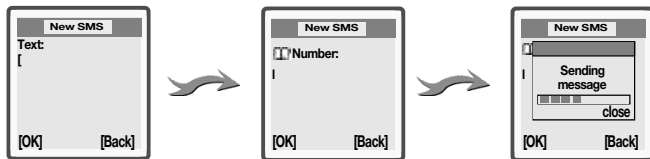

1 Press [] [] [] and enter a text message.

2 Press [] to enter the number.

3 Enter a recipient's phone number or press [] to retrieve a number or a group from the phone book and press [] then, you will see "Sending Message".



4) Unsent

Press [] [] [] and you will see a list of messages not sent properly. Select a message with the navigation key and press [] then, a recipient's phone number and a message to be displayed. Press [] to send, save or delete the unsent message.

1. SEND

1 Send the unsent SMS.
Press [] and enter a new message or edit an existing one.

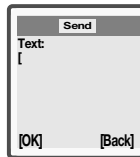

2 press [] .

3 Enter a recipient's phone number and press [] then, you will see "Sending Message"

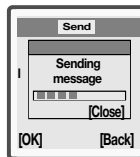

2. SAVE

Save the unsent SMS.
Press [] and you will see “Saved on card #”.

- Once the card memory is full, this item won't be available.

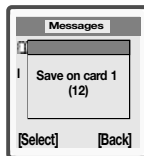

3. DELETE

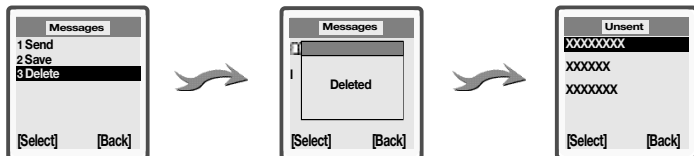

Delete the unsent SMS.
Press [] and you will see “Deleted”.



5) Templates

1 Press [] [] [].



2 Select a template with the navigation key and press [].

- To add a new template, Select “Add new?” and press [].
- Enter a template and press [] then, you will see “Send message now?”
- Press [] to confirm it and follow the procedure of creating SMS below.

3 You are to Use Template or Delete Template.



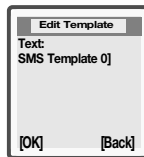

1: EDIT TEMPLATE

- 1 : Press [] and edit a text message using a template then, press [].
- 2 : Enter a phone number.
- 3 : Press [] to send the template and you will see “Sending Message”.





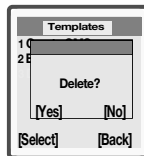

2: DELETE TEMPLATE

- 1 : Press [] to delete the template.
- 2 : Press [] to confirm it.







6) Sent Items

Press [] [] [] and you will see a list of sent messages. Select a message with the navigation key and press [] then, a recipient's phone number and a message is to be displayed. Press [] and select 1 for 'Delete', 2 for 'Forward', and 3 for 'Save'.

1. DELETE

- 1 Delete the sent SMS.
Press [] and you will see “Deleted”.

2. FORWARD

- 1 Forward the sent SMS to someone.
Press [] and the message is to be displayed. Edit the message or press [].
 - To clear a digit, press [] once.
 - To clear all the digits at a time, press and hold [].

- 2 Enter a recipient's phone number and press [] then, you will “Sending Message”

3. SAVE

- 1 Save the sent SMS. Press [].

7) Options

1. MESSAGE ALERT

1 Press [] [] [] [].

2. VOICE MAIL NO.

1 Press [] [] [] [] and a Voice Mail number is to be displayed.

2 Edit the existing Voice Mail number or enter a new one.

3 Press [] to save it.

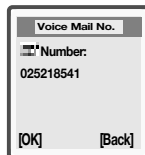

3. SERVICE CENTRE

1 Press [] [] [] [].

2 Select a phone number of service center or add a new one Press [].



3 Edit the existing phone number or enter a new one.

4 Press [] to save it.

4. AREA INFO

1 Press [] [] [] [].

1: RECEPTION

To turn area information on or off

- On
- Off

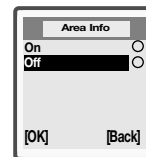

2: EDIT LIST

To enter an area information code.

- Add new?



5. CELL INFORMATION

1 Press [] [] [] [].

The cell information channel is used by some network operators to send messages to their subscribers within a certain network area.

- On
- Off

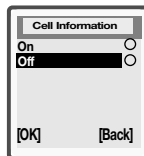

6. MESSAGE TYPE

1 Press [] [] [] [] and you will see two items displayed as follows.

1: SET ON SEND

Decides whether you are to set a message type whenever you send a message.

- 1 : Press [] and check into either of On or Off.
- 2 : Press [] to save it.

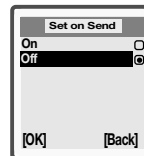

2: SET DEFAULT

Enables a message type as a default.

- 1 : Press [] and select a message type with the navigation key.
(Text/E-mail/Fax group 3/Fax group 4/Voice/Pager/ERMES)
- 2 : Press [] to set the message type as a default.

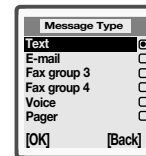

7. VALIDITY PERIOD

Press [] [] [] [] and you will see two items displayed as follows.

1: SET ON SEND

(Decides whether you are to receive a delivery acknowledgement or not)

- 1 : Press [] and check into either of On or Off.
- 2 : Press [] to save it.

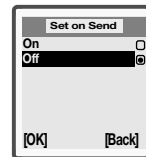

2: SET DEFAULT

(Decides what time period you are to have before you receive a delivery acknowledgement.)

1 : Press [] and select a time period with the navigation key.

(1 hour/12 hours/1 day/1 week/Maximum)

2 : Press [] to set the time period as a default.

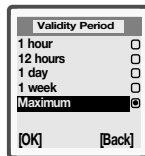

8. REPLY REQUEST

(Asks for a reply to your message)

1 Press [] [] [] [] [].

2 Check into either of On or Off and press [] to save it.

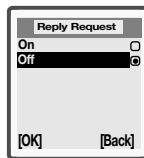

9. STARUS REQUEST

1 Press [] [] [] [].

2 Check into either of on of off and press [] to save it.

10. MEMORY STATUS

Displays the status of memories and the Card for SMS.



1 Press [] [] [] [].

8) Reference

You can enter letters and numbers and symbols into your phone for a person's name and phone number, writing a text message, and so on.

1 ENTERING LETTERS, NUMBERS & CHARACTERS

The input mode indicator appears on the middle of the each soft key.















Press and hold [] to select the desired input mode among the 4 modes as described below, then press [] select you want.















abc	abc mode : Standard input mode
T9 English	T9 English mode : Quick English input mode
123	123 mode : Number input mode
Symbol	Symbol mode : Symbol input mode

2 STANDARD INPUT MODE (abc MODE)

This mode allows you to enter English letters by using basic text input.

KEY	Character order
	Space - ? ! , . : ; " ' < = > () _ 1
	ABCÄÅÆÄÄÇZÄ(abcääæàçá2 Ä)
	DEFÈÉ3ÄÖ(d ef è é 3 Ä Ø)
	GHIÍÍ4(g h i i 4)
	JKL5 Å(j k l 5 Å)
	MNOÑÖOÓÓ6(m n o ñ ö o ò ó ö)
	PQRS 7 "±(p q r s β 7 Π Σ)
	TUVÜÙÚ8(t u v ü ù ú 8)
	WXYZ9(w x y z 9)
	+ & @ / % \$ £ 0
	To shift between capital and lower-case letters
	# *
	To delete letters and numbers
	To move the cursor

- Press the appropriate key, until the character you want appears in the display
- To enter lower-case letter, press [], enter the letter, for example an 'A'. Lower-case letters appear until you press [] again.
- To enter numbers, press and hold any numeric key.
- To delete letters and numbers, press [].

- Select **Abc** mode, by pressing [].
- When you select this mode, the abc indicator appears on the middle of the each soft key.
- Find the key that corresponds to the letter you want to enter.
 - Press it as many times as needed for the letter to appear on the screen.
 - To enter the name "John":
 Press [] J
 Press [] [] [] o
 Press [] [] h
 Press [] [] n



3 T9 ENGLISH MODE

This mode allows you to enter English letters with only once key pressing. This way, you press each key only once, even if the letter you want is not the first letter on the key. When you press the keys, a word is suggested.

KEY	Character order
	A B C A A Æ Ä Å Ç 2 Ä (a b c á ä æ à ç á 2 Ä)
	D E F È É 3 Ä Ö (d e f è é 3 Ä Ö)
	G H I Í 4 (g h i i 4)
	J K L 5 Å (j k l 5 Å)
	M N O Ñ Ö Ö Ö 6 (m n o ñ ö ö ö 6)
	P Q R S 7 ± (p q r s β 7 Π Σ)
	T U V Ü Ú Ú 8 (t u v ü ú ú 8)
	W X Y Z 9 (w x y z 9)

To write "phone book" in the T9 English mode.

- Press [] to select the T9 English mode.

- Press [][][][] and you will see "phone" highlighted.

Press [] to view other possible words then press [] to select.

- Press [] for a space

- Press [][][][] and you will see "book" highlighted. Press [] to move to the next matching word and [] to select the compound word or [] to give a space.



	To add a space.
	To shift between capital and lower-case letters
	Press repeatedly to scroll between the suggested words.
	To delete letters and numbers
	To move the cursor

5 SYMBOL MODE

This mode allows you to enter symbol easily.

1 Press [] key to change the mode for symbol.

2 Move cursor by [] key to select a symbol.

3 Select the character by press [] key.

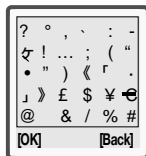

6 123...MODE

This mode allows you to enter numbers by pressing the appropriate key.

6. E-mail

E-MAIL

You can use your phone to send and receive e-mail messages. This menu supports SMTP protocol for E-mail sending and POP3 protocol for receiving. For more information, consult your service provider.

Before you start

First make sure that you have:





- Set up a data account. "E-mail options - Email settings - Set E-mail profile → Access" on page?
- Set up and select an E-mail account. See "E-mail Options – Email Settings" on page ?.

1) Inbox

You can read, reply to and forward received E-mail messages.

1 Press [] [] [] to read received messages.

2 When the e-mail messages have been downloaded from the E-mail server to your phone, scroll to select them with navigation key.

3 Press [] to read the selected one in the list. After reading, you can select the following option menus by pressing []. Select [] for 'REPLY', [] for 'Delete' and [] for 'CopyToArchive'.

1. REPLY

Reply to the sender.

1 Press [], then edit the message in the e-mail editor.

2 After editing the message, press [] to send the e-mail message.

2. DELETE

Delete the received e-mail messages.

1 Press [] and you will see "Deleted"

3. COPY TO ARCHIVE

You can archive an e-mail message in order to read it later, or if you want to save import information.

1 Press [] and you will see "Saved". And then you find the saved message in Archive menu("6) Archive" menu on page ?).

4. CALL

Call the number in the E-mail message.

1 Press [] key and you will call.

- This menu is enabled when you select the included number in the E-mail message.

5. GO TO

Go to URL in the E-mail message.

1 Press [] key and you will go to.

- This menu is enabled when you select the included number in the E-mail message.

2) New E-mail

1 Press [] [] [] to write an e-mail message.

1. TO:

1 Enter an e-mail address which message is sent directly to the recipient. After writing, press [].

2. Cc:

1 If you want to send a copy of the message to someone, enter an e-mail address which message is sent to the recipient. And then, press [].

3. SUBJECT:

1 Write a title. After editing, press [].

4. TEXT:

1 Write your messages. After editing, press []. And then you will see “Sending Message”.

3) Sent Items

- 1 Press [] [] [] and you will see a list of messages which sent (If any). Select a message with the navigation key and press [] then, a recipient's e-mail address and a message is to be displayed. Press [] and select [] for 'Send' or [] for 'Delete'.

1. SEND

Send the sent message.

- 1 Enter a new message or edit an existing one.
- 2 After editing the message, press [] to send the e-mail message. And then you will see "Sending Message".

2. DELETE

Delete the sent e-mail messages.

- 1 Press [] and you will see "Deleted"

4) Unsent

- 1 Press [] [] [] and you will see a list of messages not sent properly(If any). Select a message with the navigation key and press [] then, a recipient's e-mail address and a message is to be displayed. Press [] and select [] for 'Send' or [] for 'Delete'.

1. SEND

Send the unsent message.

- 1 Enter a new message or edit an existing one.
- 2 After editing the message, press [] to send the e-mail message. And then you will see "Sending Message".

2. DELETE

Delete the unsent e-mail messages.

- 1 Press [] and you will see "Deleted"

5) Archive

1 Press [] [] [] and you will see a list of messages which have saved before(if any).

- Select a message with the navigation key, and then press [] to read it.
- Other wise, if you will delete any message in the list, press [].

6) Options

1. E-MAIL PROFILE

Select the preferred E-mail profile which is edited in “2) E-mail Settings”.

1 Press [] [] [] [] [] to select profile.

2. E-MAIL SETTINGS

If you want to use E-mail service, you must save the settings for E-mail service.

1 Press [] [] [] [] [] to select profile.

1: RENAME

Change the selected profile name.

1 : Press [] [] [] [] [] [] to set profile.

2: ACCESS SETTINGS

Set the information to access the E-mail server.

1 : Press [] [] [] [] [] [] to set profile.

1. Access Type

Select the access type (GSM data or GPRS).

GPRS Setting

-APN

Enter the APN(Access Point Name) which supported at mobile service provider (This menu is enabled when you selected GSM type(in Access type)).

- User ID
- Password

< >
1. APN :
2. User ID
3. Password

GSM Setting

If you selected the GSM type in Access type, 'Phone Number' menu is displayd.

Otherwise, when you selected the GPRS thpe, 'APN' menu is displayed.

-Phone Number : Enter the phone number which supported at mobile service provider

- User ID
- Password

< >
1. Phone number : 17266
2. User ID : wap
3. Password : wap

2. DNS IP Address

Enter DNS(Domain Name Server)IP address of the service provider for outgoing and incoming e-mail messages.

- Enter a DNS IP address, and then press [] key to save it.

3: POP3 SERVER

Enter the name or IP address of the service provider for incoming e-mail messages.

1 : Press [] [] [] [] [] to set profile.

4: POP3 PORT

Change the number of the port used by the POP3 protocol (If needed).

1 : Press [] [] [] [] [] to set profile.

5: MAILBOX

Enter an E-mail ID, password and E-mail address for the e-mail account which E-mail service provider support.

1 : Press [] [] [] [] [] to set profile.

1. USER ID

Enter a password for the e-mail account.

2. PASSWORD

Enter a password for the e-mail account.

3. E-MAIL ADDRESS

Enter the user e-mail address.

6: SMTP SERVER

Enter the name or IP address of the service provider for outgoing e-mail messages.

1 : Press [] [] [] [] [] to set profile.

7: SMTP PORT

Change the number of the port used by the SMTP protocol(If needed).

1 : Press [] [] [] [] [] to set profile.

8: FROM NAME

Enter the user name.

1 : Press [] [] [] [] [] to set profile.

9: COPY OUTGOING

Select 'On', if you want e-mail messages sent from your phone also to be sent to an e-mail address of your choice. This way, your sent messages are copied and can be saved for future reference.

1 : Press [] [] [] [] [] to set profile.

7. Accessories

1) Calendar

In the calendar you can add a maximum of 25 tasks for things that you have to remember. The tasks can be edited or deleted.

1: VIEW TODAY

Press [] [] [] [] to view a date for today.

2: VIEW ALL TASKS

1 Press [] [] [] [] to view all tasks you entered.

2 Press [] to delete a task shown.

3: VIEW MONTH

1 Press [] [] [] [] to view a calendar by month.

- To move month to month, press [left] or [right].
- To move day to day, press [up] or [down].

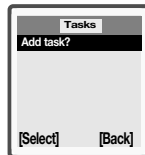
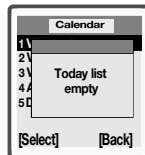

2 Press [] to add a new task or press [] to go back.

4: ADD TASK?

1 Press [] [] [] [] to add a task.

2 Enter a task and press [].
Enter a date then, press [] to save it .

3 Check into "Set Reminder" and press [].

4 Enter a date for reminder and press [] to save it.

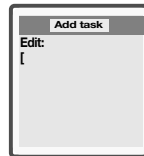

5: DELETE ALL

1 Press [] [] [] [] to delete all tasks.

2 Press [] to confirm it.

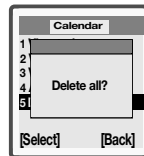



2) Alarm Clock



The phone has an alarm clock which rings at the time set, even if the phone is turned off. The alarm rings for 60 seconds and is repeated every nine minutes for 60 minutes until you turn it off.

1: CANCEL

This item won't show up when there is no set alarm.

Press [] || [] || [] || [] to cancel the alarm you set.

2: SET NEW TIME

1 Press [] || [] || [] and you will be directed to "Set New Time" when there is no set alarm.

2 Press [] only when there is already an alarm.

3 Enter hour and minute, using digit keys and press [].

- To edit the hour and minute, use the navigation key to go back and forth to each digit.







3) Timer

The phone has a built-in 24-hour timer. You set the time you want and when that time is up, the phone beeps.



1: CANCEL

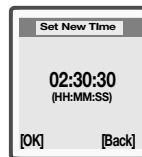

This item won't show up when there is no set timer.

Press [] || [] || [] || [] to cancel the timer you set.



2: SET NEW TIME





1 Press [] || [] || [] and you will be directed to "Set New Time" when there is no set timer.

2 Press [] only when there is already an timer. Enter hour, minute and second, using digit keys and press [].

- To edit the hour and minute, use the navigation key to go back and forth to each digit.
- The timer will appear on the idle mode.



4) World Time

Displays a time for each preprogrammed city.

1 Press [] [] [] and select one of the following cities then press [].

- 1. Madrid
- 2. London
- 3. Paris
- 4. Rome
- 5. Berlin
- 6. Athens
- 7. Cairo
- 8. Belgrade
- 9. Teheran
- 0. Karachi
(Calcutta / Rangoon / Bangkok / Beijing / Hong Kong / Taipei / Manila / Seoul / Tokyo / Melbourne / Sydney / Okhotsk / Wellington / Samoa / Honolulu / Seattle / San Francisco / Los Angeles / Denver / Phoenix / Mexico City / Chicago / Miami / New York / Georgetown / Goose Bay / Rio De Janeiro)



2  The world map is to be displayed with a date and time of city. Press [] to go back to the list.

5) Lunar Calendar

1 : SOLAR TO LUNAR

Press [] [] [] [] "Solar to Lunar".





2 : LUNAR TO SOLAR

Press [] [] [] [] "Lunar to Solar".

3 : CHINESE NEW YEAR

Press [] [] [] [] "Chinese New Year".

4 : MONTH IN LUNAR

Press [] [] [] [] "Month in Lunar".
You can see lunar day date on solar calendar.
means the first day of lunar month.



6) Voice Memo

User can store an appointment or a number through voice recording.

1 RECORD

It allows user to do voice recording while either on call or idle mode.

1 Press [] [] [] [] to play a voice memo.

2 MEMO LIST

It lists up all voice memos. When selected, a voice memo is to be played. User needs to press 'clr' to delete a selected one.

1 Press [] [] [] [] to play a voice memo.

3 ERASE ALL



You are to delete all voice memos with this feature.

1 Press [] [] [] [] to play a voice memo.

NOTE To enter voice memo when idle mode, press []





7) Stopwatch

The phone has a built-in stopwatch.

1 Press [] [] [] and a stopwatch is to be displayed.

2 Press [] to start it.

3 Press [] again to stop it.

- To reset the stop watch, press [].
- To go back to the previous page, press [] again.
- To make another stopwatch, press [] (up to 9 stopwatches)
- Press [] to make other time : up to 9 timers.



8) Calculator

Adds, Subtracts, Multiplies and Divides.

1 Press [] [] [].

- To calculate $10.5 \times 2/3 - 7 + 5$

2 Press [] [] [] [] [] [] [] to enter 10.5

3 Press [] [] [] [] [] [] [] [].

4 Press [] [] [] [].

5 Then, press [].

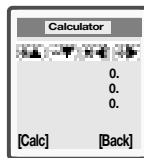

9) D-Day Setup

1: VIEW LIST

You can set some special day (special day setting).

1 Press [] [] [] [] to view a schedule with deadline.

2 Use the navigation key to go to a schedule. Each schedule is to be displayed with page, date and time.

- To delete a schedule, select which the user want to to delete press [] when the schedule is displayed on the screen.



2: INPUT NEW ITEM

- 1 Press [] [] [] [] to input a new schedule with deadline.
- 2 Enter a schedule and press [].
Enter day, month & year and press [] to save it.
- 3 Enter hour and minute and press [] to save it.
Check into one of the following items
(Bell 1~5, Melody 1~23) and press [] to save it.
- 4 Check into either "Show on idle mode" or "Hide on idle mode" and press [] to save it.

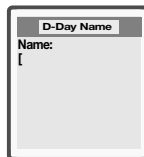

8. WAP Browser

1) Mobile Internet

If you visit the WAP site that is set as your homepage, select this menu and press "Select"

Press [] [] [].

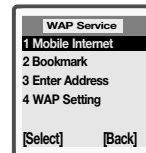

2) Bookmark

If there are some WAP pages that you often visit, you can save these as bookmarks.

- 1 Press [] [] [] to view bookmarks
- 2 Select a bookmark and press [] to connect you to a website without entering URL.

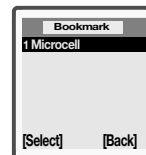

- **Go to** : Press [] to go directly to the website.
- **Edit** : Press [] to edit its address
- **Delete** : Press [] to delete it.

3) WAP Profile

Select the preferred wap profile which is edited in “6)WAP Settings”.

1 Press [] [] [] [] [] to select profile.

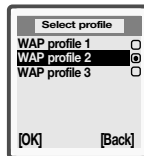

4) Enter Address

If you want to visit other WAP sites except default site.
you can use this menu.

1 Press [] [] [] [] [] to enter an address
Edit an existing address or enter a new one.

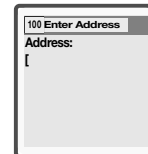

2 Press [] to connect.

5) Resume

6) WAP Settings

If you want to use WAP service, you must save the settings for WAP service.

Press [] [] [] [] to set WAP profiles.

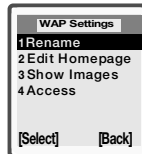

1 : RENAME

Change the profile name.

Press [] [] [] [] [] to set profiles.

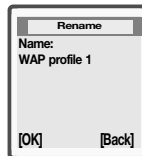

2 : EDIT HOMEPAGE

If you want to change a default homepage, You can set different homepages.

Press [] [] [] [] [] to set profiles.

<Chinamobile>

1. Title : chinamobile
2. Address : <http://wap.monternet.com>

<Chinaunicom>

1. Title : chinaunicom
2. Address : <http://211.095.065.006>



3 : SHOW IMAGES

If you want to display the images on the WAP, you can turn them on.

Press [] [] [] [] [] to set profiles.







4: ACCESS

Your mobile phone must set the information to access the WAP server.

1: RESPONSE TIME

Some WAP pages take a long time to download datas. You can set the time to stop the download attempt.

Press [] [] [] [] [] [] to set profiles.

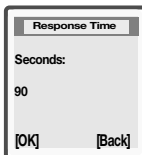

2: GPRS DATA

- 1 : User ID : wap
- 2 : Password : wap
- 3 : APN
- 4 : Quality of Serv.

<Microcell>

- 1. Phone Number : 17266
- 2. Dialtype : Analoge
- 3. User ID : wap
- 4. Password : wap

<Microcell>

- 1. Phone Number : 165
- 2. Dialtype : Analoge
- 3. User ID : wap
- 4. Password : wap

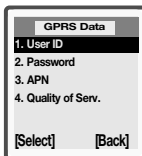

3: GATEWAY

- 1 : User ID
- 2 : Password
- 3 : Data address
- 4 : Data mode

<Microcell>

- 1. User ID
- 2. Password
- 3. Data address : 010.000.000.172
- 4. Data mode : conn.less

<Microcell>

- 1. User ID
- 2. Password
- 3. Data address : 211.095.065.130
- 4. Data mode : conn.less

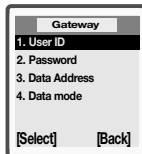

- 1 : Safety Information for Wireless Handheld Phones
- 2 : Safety Information for FCC RF Exposure
- 3 : SAR Information
- 4 : FDA Consumer Update

Safety Information for Wireless Handheld Phones

Read This Information Before Using Your Handheld Portable Cellular Telephone

EXPOSURE TO RADIO FREQUENCY SIGNALS

Your wireless handheld portable telephone is a low power radio transmitter and receiver. When it is ON, it receives and also sends out radio frequency (RF) signals.

In August 1996, the Federal Communications Commission (FCC) adopted RF exposure guidelines with safety levels for handheld wireless phones. Those guidelines are consistent with the safety standards previously set by both U.S. and international standards bodies:

- ANSI C95.1 (1992) *
- NCRP Report 88 (1986) *
- ICNIRP (1996) *

Those standards were based on comprehensive and periodic evaluations of the relevant scientific literature. For example, over 120 scientists, engineers, and physicians from universities, government health agencies, and industry reviewed the available body of research to develop the ANSI Standard (C951).

The design of your phone complies with the FCC guidelines (and those standards).

- 1* : American National Standards Institute;
- 2* : National Council on Radiation protection and measurements;
- 3* : International Commission on Nonionizing Radiation Protection;

ANTENNA CARE

Use only the supplied or an approved replacement antenna. Unauthorized antennas, modifications, or attachments could damage the phone and may violate FCC regulations.

PHONE OPERATION

Normal Position: Hold the phone as you would any other telephone with the antenna pointed up and over your shoulder.

Tips on efficient operation:

- Extend your antenna fully.
- Do not touch the antenna unnecessarily when the phone is in use. Contact with the antenna affects call quality and may cause the phone to operate at a higher power level than otherwise needed.

DRIVING SAFETY

Talking on the phone while driving is extremely dangerous and is illegal in some states. Remember, safety comes first. Check the laws and regulations on the use of phones in the areas where you drive. Always obey them.

Also, if using your phone while driving please:

- Give full attention to driving. Driving safely is your first responsibility.
- Use hands-free operation, if available.
- Pull off the road and park before making or answering a call, if driving conditions require.

ELECTRONIC DEVICES

Most modern electronic equipment is shielded from RF energy. However, certain electronic equipment may not be shielded against the RF signals from your wireless phone.

PACEMAKERS

The Health Industry Manufacturers Association recommends that a minimum separation of six (6") inches be maintained between a handheld wireless phone and a pacemaker to avoid potential interference with the pacemaker. These recommendations are consistent with the independent research by and recommendations of Wireless Technology Research.

If you have a pacemaker:

- | ALWAYS keep the phone more than six inches from your pacemaker when the phone is turned on.
- | Do not carry the phone in a breast pocket.
- | Use the ear opposite the pacemaker to minimize the potential for interference.
- | If you have any reason to suspect that interference is taking place, turn your phone OFF immediately.

HEARING AIDS

Some digital wireless phones may interfere with some hearing aids. In the event of such interference, you may want to consult your service provider (or call the customer service line to discuss alternatives).

OTHER MEDICAL DEVICES

If you use any other personal medical device, consult the manufacturer of your device to determine if they are adequately shielded from external RF energy. Your physician may be able to assist you in obtaining this information.

Turn your phone OFF in healthcare facilities when any regulations posted in these areas instruct you to do so. Hospitals or healthcare facilities may be using equipment that could be sensitive to external RF energy.

VEHICLES

RF signals may affect improperly installed or inadequately shielded electronic systems in motor vehicles. Check with the manufacturer or its representative regarding your vehicle. You should also consult the manufacturer of any equipment that has been added to your vehicle.

An airbag inflates with great force. DO NOT place objects, including both installed or portable wireless equipment, in the area over the airbag or in the air bag deployment area. If in-vehicle wireless equipment is improperly installed and the air bag inflates, serious injury could result.

POSTED FACILITIES

Turn your phone OFF where posted notices so require.

OTHER SAFETY GUIDELINES

AIRCRAFT

FCC and Transport Canada Regulations prohibit using your phone while in the air. Turn your phone OFF before boarding an aircraft.

BLASTING AREAS

To avoid interfering with blasting operations, turn your phone OFF when in a “blasting area” or in areas posted: “Turn off two-way radio.” Obey all signs and instructions.

POTENTIALLY EXPLOSIVE ATMOSPHERES

Turn your phone OFF when in any area with a potentially explosive atmosphere and obey all signs and instructions. Sparks in such areas could cause an explosion or fire resulting in bodily injury or even death.

Areas with a potentially explosive atmosphere are often, but not always, clearly marked. They include fueling areas such as gas stations; below deck on boats; fuel or chemical transfer or storage facilities; vehicles using liquefied petroleum gas (such as propane or butane); areas where the air contains chemicals or articles, such as grain, dust, or metal powders; and any other area where you would normally be advised to turn off your vehicle’s engine.

PRECAUTIONS AND WARNINGS

Please read and understand all of the Precautions and Warnings contained in this manual before attempting to operate your phone.

1. DO NOT use this equipment in an extreme environment where high temperature or high humidity exists, such as near a heater or in a closed car parked in the sun.
2. DO NOT abuse the equipment. Avoid striking, shaking or shocking. When not using the unit, lay down the unit to avoid possible damage due to instability.
3. DO NOT expose this equipment to liquids such as rain or spilled beverages.
4. DO NOT use unauthorized accessories. Use of unauthorized accessories may result in fire, electric shock or other bodily injury.
5. DO NOT disassemble the phone or its accessories. If service or repair is required, return the unit to an authorized audiovox service center. If unit is disassembled, the risk of electric shock or fire may result.
6. DO NOT short-circuit the battery terminals with metal items etc.
7. DO NOT use harsh chemicals, cleaning solvents or strong detergents to clean this phone. Always clean it with a soft, damp cloth.
8. DO NOT paint this phone. This can clog moving parts.

OPERATING PROCEDURES

Never violate any of the following Rules and Regulations of the FCC when using your phone. The following offenses are punishable by fine, imprisonment, or both:

- Using obscene, indecent, or profane language.
- Using the unit to give off false distress calls.
- Wiretapping or otherwise intercepting a telephone call, unless that person has first obtained the consent of the parties participating in the call.
- Making anonymous calls to annoy, harass, or molest other people.
- Charging to an account without authorization to avoid payment for service.
- Refusing to yield a party line when informed that it is needed for an emergency call (It is also unlawful to take over a party line by stating falsely that it is needed for an emergency).

Safety Information for FCC Rf Exposure

WARNING! Read this information before using your phone

caution

In August 1996, the Federal Communications Commission (FCC) of the United States with its action in Report and Order FCC 96-326 adopted an updated safety standard for human exposure to radio frequency electromagnetic energy emitted by FCC regulated transmitters. Those guidelines are consistent with the safety standard previously set by both U.S. and international standards bodies. The design of this phone complies with the FCC guidelines and these international standards.

Use only the supplied or an approved antenna. Unauthorized antennas, modifications, or attachments could impair call quality, damage the phone, or result in violation of FCC regulations.

Do not use the phone with a damaged antenna. If a damaged antenna comes into contact with the skin, a minor burn may result. Please contact your local dealer for replacement antenna.

"For Body worn operation, this phone has been tested and meets the FCC RF Exposure guidelines when used with an accessory that contain no metal and that positions the handset a minimum of 17mm from the body. The Holster with Part Number 2H020665002 fulfilled this requirement. Use of other accessories may not ensure compliance with FCC RF exposure guidelines."

Note: For more information about RF exposure, please visit the FCC website at www.fcc.gov.

SAR Information

THIS MODEL PHONE MEETS THE GOVERNMENT'S REQUIREMENTS FOR EXPOSURE TO RADIO WAVES.

Your wireless phone is a radio transmitter and receiver. It is designed and manufactured not to exceed the emission limits for exposure to radiofrequency (RF) energy set by the Federal Communications Commission of the U.S. Government. These limits are part of comprehensive guidelines and establish permitted levels of RF energy for the general population. The guidelines are based on standards that were developed by independent scientific organizations through periodic and thorough evaluation of scientific studies. The standards include a substantial safety margin designed to assure the safety of all persons, regardless of age and health.

The exposure standard for wireless mobile phones employs a unit of measurement known as the Specific Absorption Rate, or SAR. The SAR limit set by the FCC is 1.6 W/kg.* Tests for SAR are conducted with the phone transmitting at its highest certified power level in all tested frequency bands. Although the SAR is determined at the highest certified power level, the actual SAR level of the phone while operating can be well below the maximum value. This is because the phone is designed to operate at multiple power levels so as to use only the power required to reach the network. In general, the closer you are to a wireless base station antenna, the lower the power output.

Before a phone model is available for sale to the public, it must be tested and certified to the FCC that it does not exceed the limit established by the government-adopted requirement for safe exposure. The tests are performed in positions and locations (e.g., at the ear and worn on the body) as required by the FCC for each model. The highest SAR value for this model phone when tested for use at the ear is 1.326 W/kg and when worn on the body.

While there may be differences between the SAR levels of various phones and at various positions, they all meet the government requirement for safe exposure.

The FCC has granted an Equipment Authorization for this model phone with all reported SAR levels evaluated as in compliance with the FCC RF exposure guidelines. SAR information on this model phone is on file with the FCC and can be found under the Display Grant section of <http://www.fcc.gov/oet/fccid> after searching on FCC ID PP4GA-160C.

Additional information on Specific Absorption Rates (SAR) can be found on the Cellular Telecommunications & Internet Association (CTIA) web-site at <http://phonefacts.net>.

* In the United States and Canada, the SAR limit for mobile phones used by the public is 1.6 watts/kg (W/kg) averaged over one gram of tissue. The standard incorporates a substantial margin of safety to give additional protection for the public and to account for any variations in measurements.



U.S. Food and Drug Administration - Center for Devices and Radiological Health Consumer Update on Mobile Phones

1. Do wireless phones pose a health hazard?

The available scientific evidence does not show that any health problems are associated with using wireless phones. There is no proof, however, that wireless phones are absolutely safe. Wireless phones emit low levels of radiofrequency energy (RF) in the microwave range while being used. They also emit very low levels of RF when in the stand-by mode. Whereas high levels of RF can produce health effects (by heating tissue), exposure to low level RF that does not produce heating effects causes no known adverse health effects. Many studies of low level RF exposures have not found any biological effects. Some studies have suggested that some biological effects may occur, but such findings have not been confirmed by additional research. In some cases, other researchers have had difficulty in reproducing those studies, or in determining the reasons for inconsistent results.

2. What is FDA's role concerning the safety of wireless phones?

Under the law, FDA does not review the safety of radiation-emitting consumer products such as wireless phones before they can be sold, as it does with new drugs or medical devices. However, the agency has authority to take action if wireless phones are shown to emit radiofrequency energy (RF) at a level that is hazardous to the user. In such a case, FDA could require the manufacturers of wireless phones to notify users of the health hazard and to repair, replace or recall the phones so that the hazard no longer exists. Although the existing scientific data do not justify FDA regulatory actions, FDA has urged the wireless phone industry to take a number of steps, including the following:

- Support needed research into possible biological effects of RF of the type emitted by wireless phones;

- Design wireless phones in a way that minimizes any RF exposure to the user that is not necessary for device function; and
- Cooperate in providing users of wireless phones with the best possible information on possible effects of wireless phone use on human health.

FDA belongs to an interagency working group of the federal agencies that have responsibility for different aspects of RF safety to ensure coordinated efforts at the federal level. The following agencies belong to this working group:

- National Institute for Occupational Safety and Health
- Environmental Protection Agency
- Federal Communications Commission
- Occupational Safety and Health Administration
- National Telecommunications and Information Administration

The National Institutes of Health participates in some interagency working group activities, as well. FDA shares regulatory responsibilities for wireless phones with the Federal Communications Commission (FCC). All phones that are sold in the United States must comply with FCC safety guidelines that limit RF exposure. FCC relies on FDA and other health agencies for safety questions about wireless phones. FCC also regulates the base stations that the wireless phone networks rely upon. While these base stations operate at higher power than do the wireless phones themselves, the RF exposures that people get from these base stations are typically thousands of times lower than those they can get from wireless phones. Base stations are thus not the subject of the safety questions discussed in this document.

3. What kinds of phones are the subject of this update?

The term “wireless phone” refers here to hand-held wireless phones with built-in antennas, often called “cell,” “mobile,” or “PCS” phones. These types of wireless phones can expose the user to measurable radiofrequency energy (RF) because of the short distance between the phone and the user’s head. These RF exposures are limited by Federal Communications Commission safety guidelines that were developed with the advice of FDA and other federal health and safety agencies. When the phone is located at greater distances from the user, the exposure to RF is drastically lower because a person’s RF exposure decreases rapidly with increasing distance from the source. The so-called “cordless phones,” which have a base unit connected to the telephone wiring in a house, typically operate at far lower power levels, and thus produce RF exposures far below the FCC safety limits.

4. What are the results of the research done already?

The research done thus far has produced conflicting results, and many studies have suffered from flaws in their research methods. Animal experiments investigating the effects of radiofrequency energy (RF) exposures characteristic of wireless phones have yielded conflicting results that often cannot be repeated in other laboratories. A few animal studies, however, have suggested that low levels of RF could accelerate the development of cancer in laboratory animals. However, many of the studies that showed increased tumor development used animals that had been genetically engineered or treated with cancer-causing chemicals so as to be pre-disposed to develop cancer in the absence of RF exposure. Other studies exposed the animals to RF for up to 22 hours per day. These conditions are not similar to the conditions under which people use wireless phones, so we don’t know with certainty what the results of such studies mean for human health.

Three large epidemiology studies have been published since December 2000. Between them, the studies investigated any possible association between the use of wireless phones and primary brain cancer, glioma, meningioma, or acoustic neuroma, tumors of the brain or salivary gland, leukemia, or other cancers. None of the studies demonstrated the existence of any harmful health effects from wireless phone RF exposures. However, none of the studies can answer questions about long-term exposures, since the average period of phone use in these studies was around three years.

5. What research is needed to decide whether RF exposure from wireless phones poses a health risk?

A combination of laboratory studies and epidemiological studies of people actually using wireless phones would provide some of the data that are needed. Lifetime animal exposure studies could be completed in a few years. However, very large numbers of animals would be needed to provide reliable proof of a cancer promoting effect if one exists. Epidemiological studies can provide data that is directly applicable to human populations, but 10 or more years’ follow-up may be needed to provide answers about some health effects, such as cancer. This is because the interval between the time of exposure to a cancer-causing agent and the time tumors develop - if they do - may be many, many years. The interpretation of epidemiological studies is hampered by difficulties in measuring actual RF exposure during day-to-day use of wireless phones. Many factors affect this measurement, such as the angle at which the phone is held, or which model of phone is used.

6. What is FDA doing to find out more about the possible health effects of wireless phone RF?

FDA is working with the U.S. National Toxicology Program and with groups of investigators around the world to ensure that high priority animal studies are conducted to address important questions about the effects of exposure to radiofrequency energy (RF).

FDA has been a leading participant in the World Health Organization International Electromagnetic Fields (EMF) Project since its inception in 1996. An influential result of this work has been the development of a detailed agenda of research needs that has driven the establishment of new research programs around the world. The Project has also helped develop a series of public information documents on EMF issues.

FDA and the Cellular Telecommunications & Internet Association (CTIA) have a formal Cooperative Research and Development Agreement (CRADA) to do research on wireless phone safety. FDA provides the scientific oversight, obtaining input from experts in government, industry, and academic organizations. CTIA-funded research is conducted through contracts to independent investigators.

The initial research will include both laboratory studies and studies of wireless phone users. The CRADA will also include a broad assessment of additional research needs in the context of the latest research developments around the world.

7. How can I find out how much radiofrequency energy exposure I can get by using my wireless phone?

All phones sold in the United States must comply with Federal Communications Commission (FCC) guidelines that limit radiofrequency energy (RF) exposures. FCC established these guidelines in consultation with FDA and the other federal health and safety agencies. The FCC limit for RF exposure from wireless telephones is set at a Specific Absorption Rate (SAR) of 1.6 watts per kilogram (1.6 W/kg). The FCC limit is consistent with the safety standards developed by the Institute of Electrical and Electronic Engineering (IEEE) and the National Council on Radiation Protection and Measurement. The exposure limit takes into consideration the body's ability to remove heat from the tissues that absorb energy from the wireless phone and is set well below levels known to have effects.

Manufacturers of wireless phones must report the RF exposure level for each model of phone to the FCC. The FCC website (<http://www.fcc.gov/oet/rfsafety>) gives directions for locating the FCC identification number on your phone so you can find your phone's RF exposure level in the online listing.

8. What has FDA done to measure the radiofrequency energy coming from wireless phones ?

The Institute of Electrical and Electronic Engineers (IEEE) is developing a technical standard for measuring the radiofrequency energy (RF) exposure from wireless phones and other wireless handsets with the participation and leadership of FDA scientists and engineers. The standard, "Recommended Practice for Determining the Spatial-Peak Specific Absorption Rate (SAR) in the Human Body Due to Wireless Communications Devices: Experimental Techniques," sets forth the first consistent test

methodology for measuring the rate at which RF is deposited in the heads of wireless phone users. The test method uses a tissue-simulating model of the human head. Standardized SAR test methodology is expected to greatly improve the consistency of measurements made at different laboratories on the same phone. SAR is the measurement of the amount of energy absorbed in tissue, either by the whole body or a small part of the body. It is measured in watts/kg (or milliwatts/g) of matter. This measurement is used to determine whether a wireless phone complies with safety guidelines.

9. What steps can I take to reduce my exposure to radiofrequency energy from my wireless phone?

If there is a risk from these products—and at this point we do not know that there is—it is probably very small. But if you are concerned about avoiding even potential risks, you can take a few simple steps to minimize your exposure to radiofrequency energy (RF). Since time is a key factor in how much exposure a person receives, reducing the amount of time spent using a wireless phone will reduce RF exposure.

- If you must conduct extended conversations by wireless phone every day, you could place more distance between your body and the source of the RF, since the exposure level drops off dramatically with distance. For example, you could use a headset and carry the wireless phone away from your body or use a wireless phone connected to a remote antenna. Again, the scientific data do not demonstrate that wireless phones are harmful. But if you are concerned about the RF exposure from these products, you can use measures like those described above to reduce your RF exposure from wireless phone use.

10. What about children using wireless phones?

The scientific evidence does not show a danger to users of wireless phones, including children and teenagers. If you want to take steps to lower exposure to radiofrequency energy (RF), the measures described above would apply to children and teenagers using wireless phones. Reducing the time of wireless phone use and increasing the distance between the user and the RF source will reduce RF exposure. Some groups sponsored by other national governments have advised that children be discouraged from using wireless phones at all. For example, the government in the United Kingdom distributed leaflets containing such a recommendation in December 2000. They noted that no evidence exists that using a wireless phone causes brain tumors or other ill effects. Their recommendation to limit wireless phone use by children was strictly precautionary; it was not based on scientific evidence that any health hazard exists.

11. What about wireless phone interference with medical equipment?

Radiofrequency energy (RF) from wireless phones can interact with some electronic devices. For this reason, FDA helped develop a detailed test method to measure electromagnetic interference (EMI) of implanted cardiac pacemakers and defibrillators from wireless telephones. This test method is now part of a standard sponsored by the Association for the Advancement of Medical Instrumentation (AAMI). The final draft, a joint effort by FDA, medical device manufacturers, and many other groups, was completed in late 2000. This standard will allow manufacturers to ensure that cardiac pacemakers and defibrillators are safe from wireless phone EMI.

FDA has tested hearing aids for interference from handheld wireless phones and helped develop a voluntary standard sponsored by the Institute of Electrical and Electronic Engineers (IEEE). This standard specifies test methods and performance requirements for hearing aids and wireless phones so that no interference occurs when a person uses a "compatible" phone and a "compatible" hearing aid at the same time. This standard was approved by the IEEE in 2000.

FDA continues to monitor the use of wireless phones for possible interactions with other medical devices. Should harmful interference be found to occur, FDA will conduct testing to assess the interference and work to resolve the problem.

12. Where can I find additional information? For additional information, please refer to the following resources:

- FDA web page on wireless phones:
(<http://www.fda.gov/cdrh/phones/index.html>)
- Federal Communications Commission (FCC) RF Safety Program: (<http://www.fcc.gov/oet/rfsafety>)
- International Commission on Non-Ionizing Radiation Protection:
(<http://www.icnirp.de>)
- World Health Organization (WHO) International EMF Project:
(<http://www.who.int/emf>)
- National Radiological Protection Board (UK):
(<http://www.nrp.org.uk/>)