

LIFE FITNESS CONSUMER DIVISION

14150 Sunfish Lake Blvd. Ramsey Minnesota, 55303 U.S.A.
Tel: 763.323.4500 Fax: 763.323.4797
800.328.9714 (Toll-free within the U.S. and Canada)
www.parabody.com

INTERNATIONAL OFFICES

Life Fitness Atlantic BV
Atlantic Headquarters
Bijdorplein 25-31
2992 LB Barendrecht
The Netherlands
Phone: (180) 646 666
Fax: (180) 646 703

Life Fitness EUROPE GmbH
Siemensstrasse 3
85716 Umerschleissheim
Germany
Phone: (089) 31 77 51-0
Fax: (089) 31 77 51 99

Life Fitness Italia S.R.L.
Via Elvas 92
39042 Bressanone
Italy
Phone: 39 (472) 835-470
Fax: 39 (472) 833-150

Life Fitness Asia Pacific Limited
Room 2610, Miramar Tower
132 Nathan Road, Tsimshatsui
Kowloon, Hong Kong
Phone: (852) 2891-6677
Fax: (852) 2575-6001

Life Fitness (UK) Ltd.
Queen Adelaide
Ely, Cambs CB7 4UB
United Kingdom
Phone CSS: (01353) 665507
Fax CSS: (01353) 666719

Life Fitness Benelux N.V.
Bijdorplein 25-31
2992 LB Barendrecht
The Netherlands
Phone: 31 (180) 64 66 69
Fax: 31 (180) 64 66 99

Life Fitness Japan
8/F, Nippon Brunswick Building
5-27-7 Sendagaya
Shibuya-Ku, Tokyo 151-0051
Japan
Phone: 81 (3) 3359-4309
Fax: 81 (3) 3359-4307

Life Fitness Do Brazil
Al. Rio Negro, 433-Predio 2-Sala 2
3º andar (Confab)
Aplhaville-Barueri-Sao Paulo
CEP: 06454-904
Brazil
Phone: 55 (11) 7295-2217
Fax: 55 (11) 7295-2218

PARABODY®

843 RACK SYSTEM

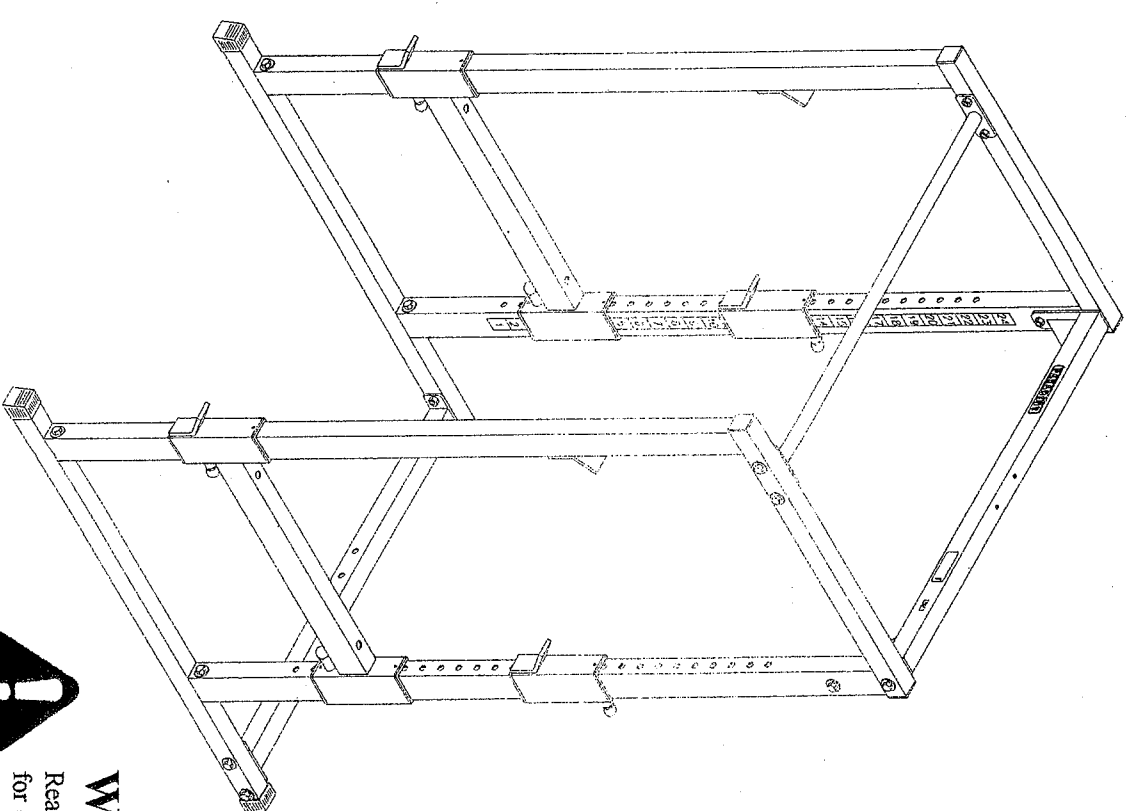

WARNING:
Read and follow all directions
for each step to insure proper
assembly of this product.

USER'S GUIDE

CLASSH
PART # 7066601
REV. A

1

Version: 843107
Revision: 02/12/01

TABLE OF CONTENTS

Safety Statement.....	2
General Notes.....	3
Tools Required.....	3
Gym Layout.....	4
Parts list.....	5
Assembly Instructions.....	5-9
General Maintenance.....	10
Warranty Statement.....	11
Product Services.....	12
Insert-Registration Card	

IMPORTANT SAFETY INFORMATION



THERE IS A RISK ASSUMED BY INDIVIDUALS WHO USE THIS TYPE OF EQUIPMENT. TO MINIMIZE RISK FOLLOW THESE RULES!

1. Before using, read all the warnings and instructions on the use of this machine. Use only for intended purpose. DO NOT modify the machine.
2. Obtain a medical exam before beginning any exercise program.
3. Keep body and clothing free of all moving objects.
4. Repair the machine before use. DO NOT use if it appears damaged. DO NOT attempt to fix a broken or jammed machine. Notify your authorized ParaBody dealer before use and have repairs made by an authorized service technician.
5. Be certain that weight pin is completely inserted. Use only the pin provided by the manufacturer. If unsure, call your authorized ParaBody dealer.
6. Never pin the weights or prop pins into an elevated position. DO NOT use the machine if found in this condition. DO NOT attempt to fix. Notify your authorized ParaBody dealer.
7. Inspect cotter and then remove one before using machine. Pay particular attention to the cable ends. DO NOT attempt to fix. Notify your authorized ParaBody dealer before use and have repairs made by an authorized service technician.
8. Make sure all spring loaded pull pins are fully engaged in the adjustment position and fully tighten thumbscrew before use.
9. Children must not be allowed near this machine. Supervise teenagers.

NOTE: In a continual effort to improve our products, specifications are subject to change
 © 2001 Life Fitness, a division of Brunswick Corporation. All rights reserved.
 ParaBody is a trademark of Brunswick Corporation

LIMITED WARRANTY

ParaBody extends the following LIMITED WARRANTY to the original owner of the ParaBody products. The Warranty terms apply to IN HOME USE ONLY.

1. **LIMITED WARRANTY ON FRAME AND WELDS.** If the frame of the ParaBody product or a weld should crack or break, it will be repaired or replaced by ParaBody. Terms: Lifetime – for so long as the Customer owns the ParaBody product.
2. **LIMITED WARRANTY ON PARTS.** If the following parts are defective in material or workmanship, ParaBody will supply replacement parts: all bolts, nuts, washers, bearings, bushings, pulleys, thumb screws, collars, cable retaining clips, adjustable pre-stretch slides, roller pad shafts, allen head bolts, weight selector pin, weight stack shaft, set screws, protector caps, adjustment chain, cotter pin, plunger, spring and knob. Terms: Lifetime – for so long as the Customer owns the ParaBody product.
3. **LIMITED WARRANTY ON CABLES AND UPHOLSTERY.** If the coated cables or upholstery are defective in material or workmanship, ParaBody will repair or replace them, at its option. Terms: Three (3) years.
4. **CONDITIONS AND EXCEPTIONS.** Any product misuse, abuse or alteration, any attempt to repair by a person other than an authorized ParaBody Service Center, any improper assembly, accident, or any other condition resulting from occurrences beyond the control of ParaBody will void this Limited Warranty.
5. **REPLACEMENT AND REPAIR EXPENSES.** ParaBody will provide only replacement parts or repair under this warranty. The Owner is responsible for all other costs. Such costs may include, but are not limited to: a. labor charges for service, removal, repair or reinstallation of the ParaBody product or any component part; b. shipping, delivery, handling and administrative charges for returning parts to ParaBody; and c. all necessary or incidental costs related to installation of the replacement parts.
6. **SHIPPING.** If shipping by the Owners is deemed necessary (in sole discretion of ParaBody), parts should be shipped in their original carton or equivalent packaging, fully insured with shipping charges prepaid. ParaBody will not assume any responsibility for any loss or damage incurred in shipping.
7. **CLAIM PROCEDURES.** If service on your ParaBody product is required during the warranty period, please contact our Customer Service Department at 1-800-328-9714 for instructions regarding returning or replacing parts. Please have available the following information: (i) the dealer's name; (ii) the date of purchase; (iii) the serial # (s) of your product (the serial number location is called out on the final assembly drawing included with your assembly instructions); (iv) a description of the nature of the problem.
8. **OWNER'S RIGHT.** This Limited Warranty gives you specific legal rights. You may also have other rights, which vary depending on local law.
9. **LIMITATION OF IMPLIED WARRANTIES.** All implied warranties, except to the extent prohibited by applicable law, shall have no greater duration than the warranty period set forth above. There are no warranties which extend beyond the description in this Limited Warranty. Because local laws do not allow limitations on how long an implied warranty lasts, the above limitations may not apply to you.
10. **DISCLAIMER.** No other express warranty has been made or will be made on behalf of ParaBody with respect to any ParaBody product or the operation, repair or replacement of any ParaBody product. ParaBody shall not be responsible for injury, loss of use of the ParaBody product, inconvenience, loss or damage to personal property, whether direct or indirect, and incidental or consequential damages, so the above limitation of exclusion may not apply to you.

NOTES:

MAINTENANCE

Please note:

- * We recommend cleaning your product (pads and frame) on a regular basis, using warm soapy water. Touch-up paint can be purchased from your ParaBody customer service representative at (800) 328-9714.
- * Inspect equipment daily. Tighten all loose connections or replace worn parts immediately. Failure to do so may result in serious injury
- * Lubricate guide rods with a teflon based (or equivalent) lubricant on a regular basis

PLEASE RECORD THE INFORMATION REQUESTED BELOW. IN THE EVENT YOU MAY NEED SERVICE YOU WILL BE ASKED FOR THIS INFORMATION. REFER TO THE MEMBER TO FILL OUT YOUR WARRANTY REGISTRATION CARD AND MAIL BACK.

MODEL # _____

SERIAL # _____

DATE OF PURCHASE: _____

DEALERS NAME: _____

DEALERS PHONE # _____

Thank you for purchasing the ParaBody 843 Rack System.

IMPORTANT NOTES

Please note:

- * Thank you for purchasing the ParaBody 843 Rack System. Please read these instructions thoroughly and keep them for future reference. This product must be assembled on a flat, level surface to assure its proper function.
- * This product must be assembled on a flat, level surface to assure its proper function. DO NOT securely tighten any frame connections until the entire frame has been assembled, unless otherwise stated.

Tools Required for Assembly

- * 3/4" wrench
- * Ratchet with 3/4" and 9/16" sockets
- * Rubber Mallet or Hammer

Bolt Length Ruler

NOTE: BOLT LENGTH IS MEASURED FROM THE UNDERSIDE OF THE HEAD OF THE BOLT.

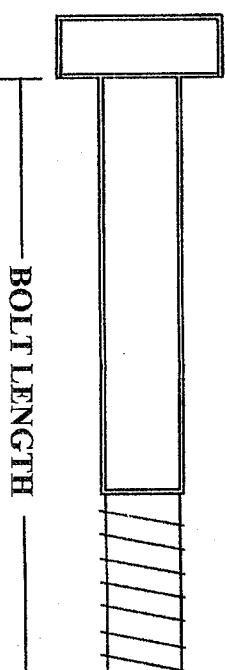

BOLT LENGTH RULER:

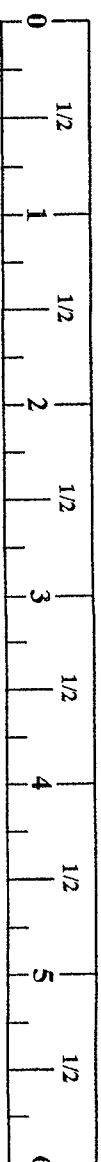

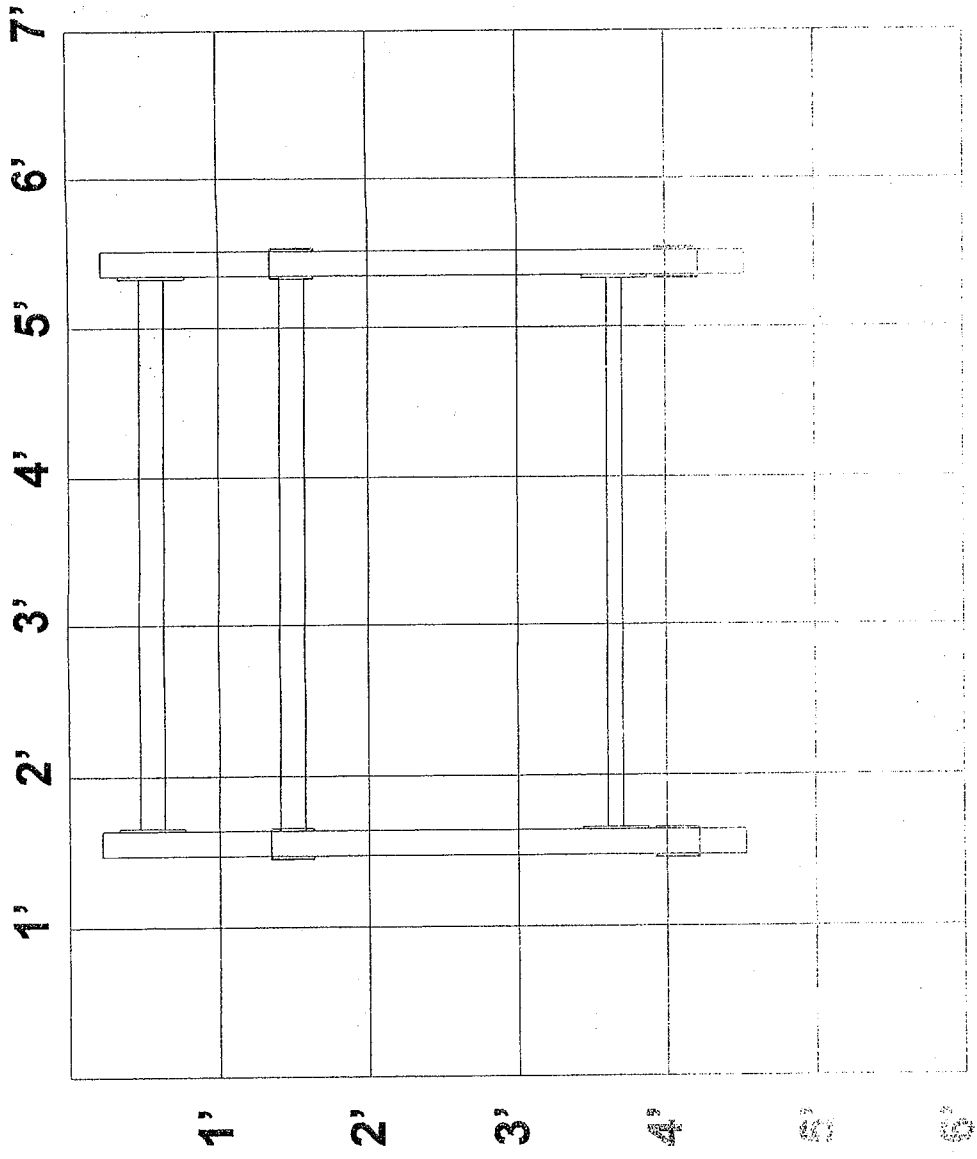

1 Square = 1' X 1'

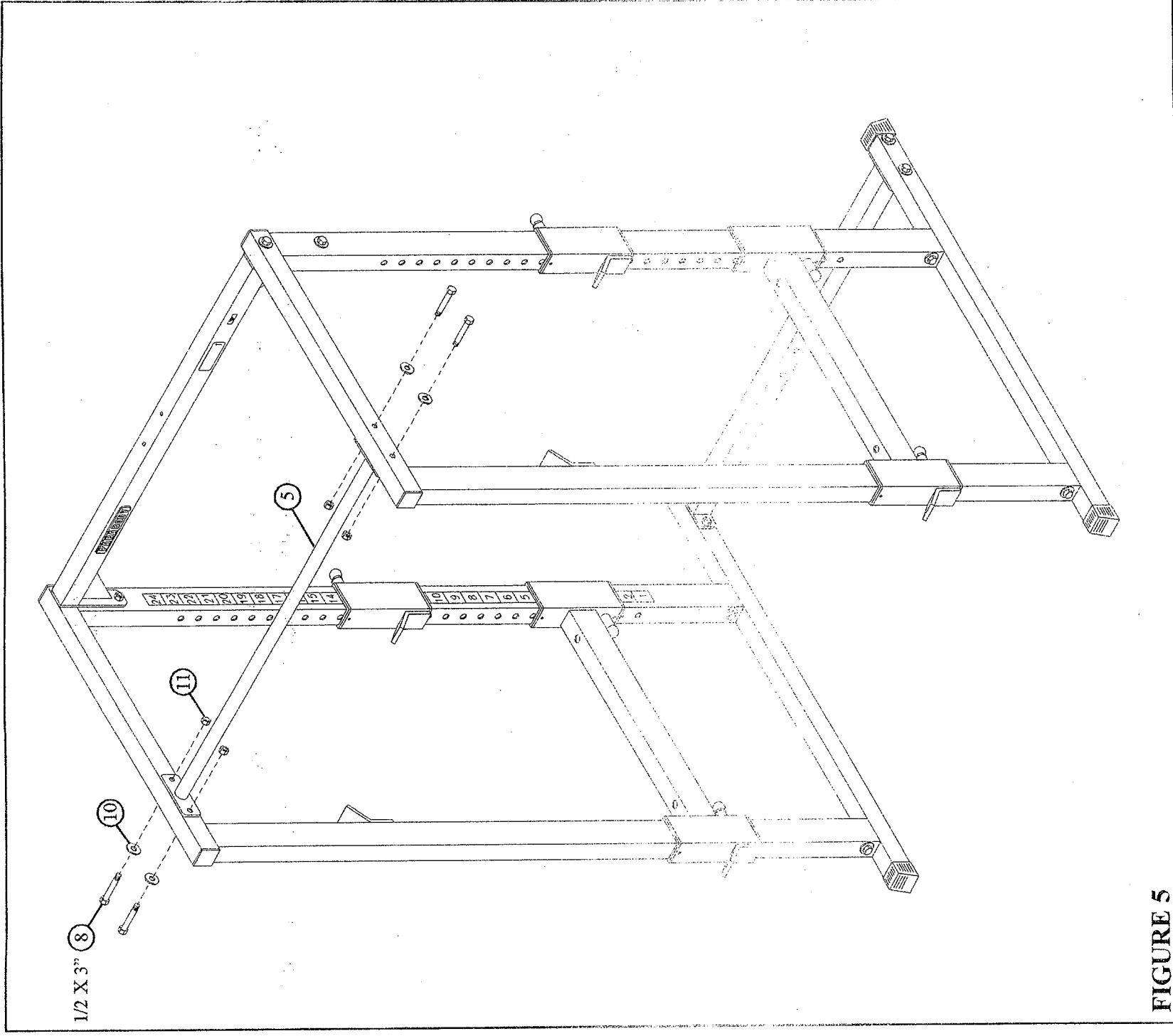

FIGURE 5

STEP 5:

- LOOSELY assemble the CHIN BAR (5) using four 1/2 X 3" BOLTS (8), four 1/2" WASHERS (10), and four 1/2" LOCK NUTS (11). See FIGURE 5.

When all components are assembled, SECURELY tighten all bolt connections.

THIS CONCLUDES THE ASSEMBLY OF THE 843 RACK SYSTEM.

PARTS LIST

KEY	PART #	DESCRIPTION	QTY	KEY	PART #	DESCRIPTION	QTY
1	6641508	UPRIGHT	2	9	3102917	1/2 X 4" BOLT	4
2	6641802	UPRIGHT BASE	2	10	3102502	1/2" WASHER	20
3	6605702	SAFETY RAIL	2	11	3102801	1/2" LOCK NUT	14
4	6605802	BAR SUPPORT	2	12	6606801	SPRING PIN ASSEMBLY	6
5	6605902	CHIN BAR	1	13	6405201	2" SQ. END CAP	4
6	6606002	LOWER CONNECTOR	1	14	6467001	2" SQ. COVER CAP	4
7	6606102	UPPER CONNECTOR	1	15	6590801	3 X 2" INSERT GUIDE	12
8	3102910	1/2 X 3" BOLT	12				

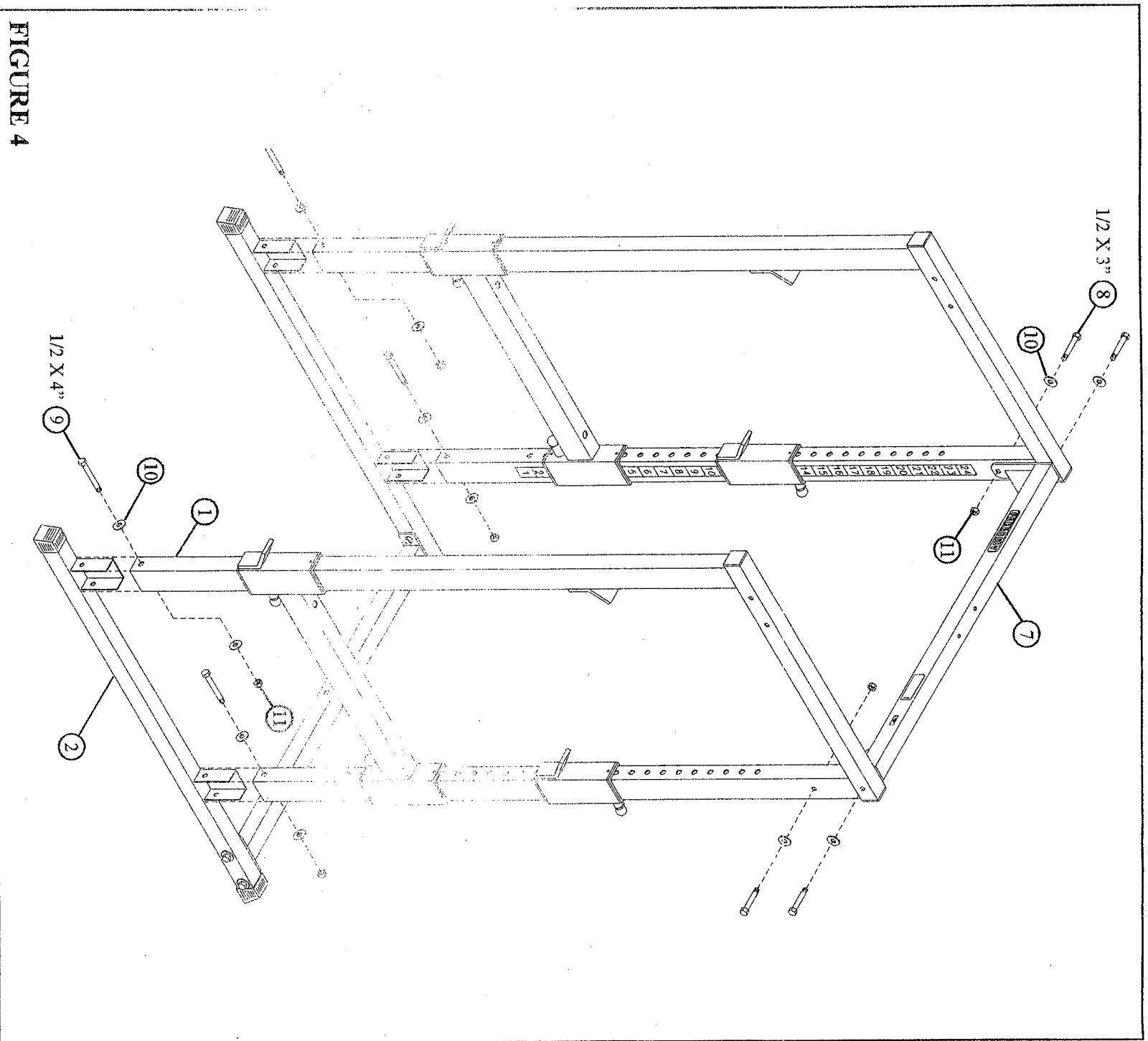

STEP 4:

- LOOSELY assemble each UPRIGHT (1) to the UPRIGHT BASE (2) using four 1/2 X 4" BOLTS (9), eight 1/2" WASHERS (10), and four 1/2" LOCK NUTS (11). See FIGURE 4.
- LOOSELY assemble the UPPER CONNECTOR (7) using four 1/2 X 3" BOLTS (8), four 1/2" WASHERS (10), and two 1/2" LOCK NUTS (11). See FIGURE 4.

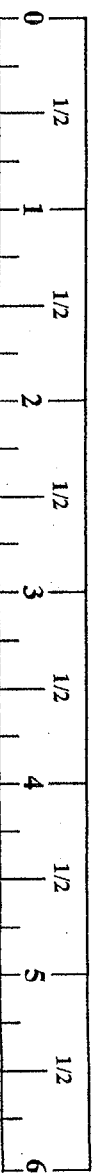

8

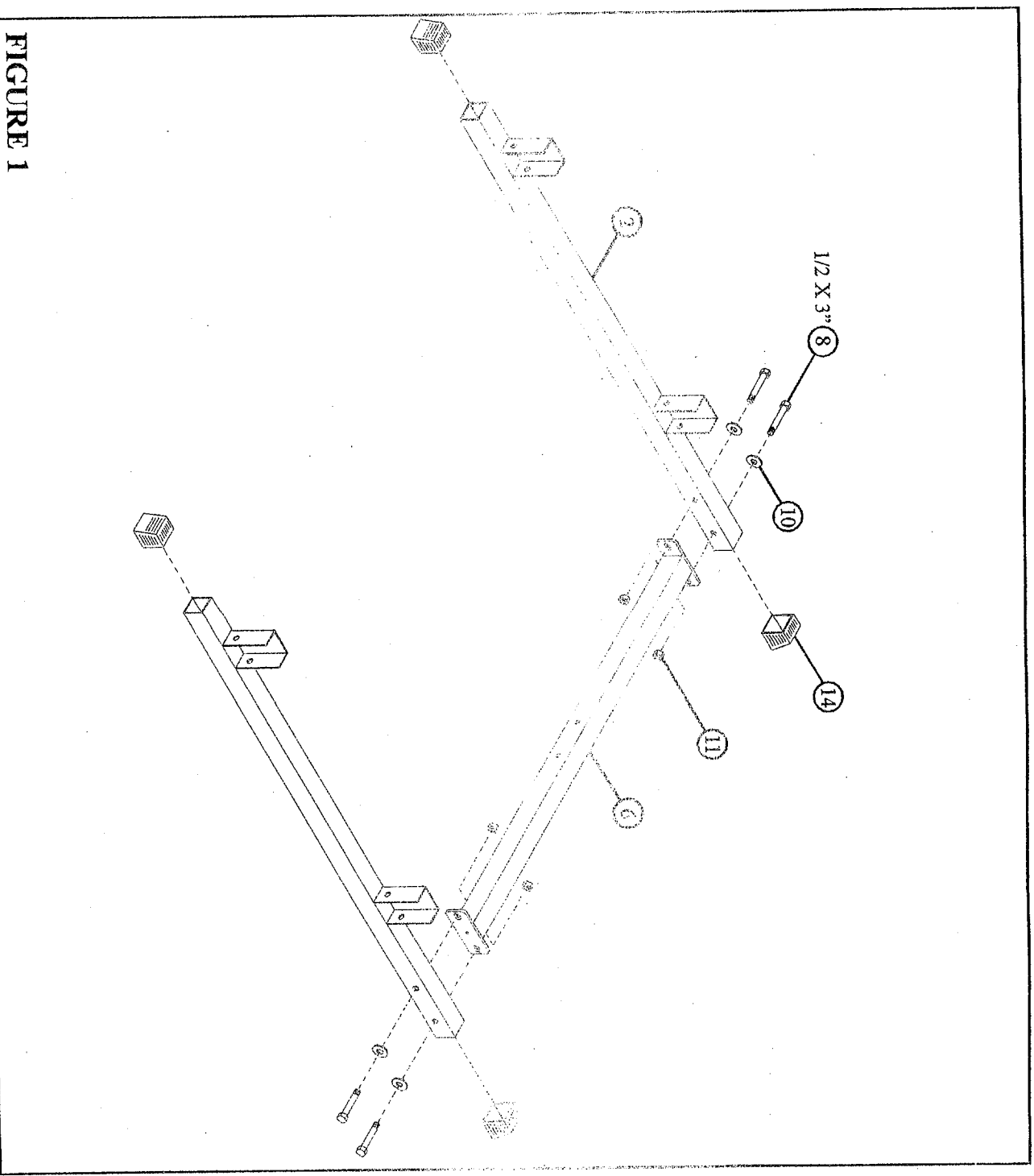

STEP 1:

- Slide four 2" SQ. COVER CAPS (14) over the ends of each UPRIGHT BASE (2) as shown in FIGURE 1.
- LOOSELY assemble the LOWER CONNECTOR (6) between each UPRIGHT BASE (2) using four 1/2 X 3" BOLTS (8), four 1/2" WASHERS (10), and four 1/2" LOCK NUTS (11). See FIGURE 1.

5

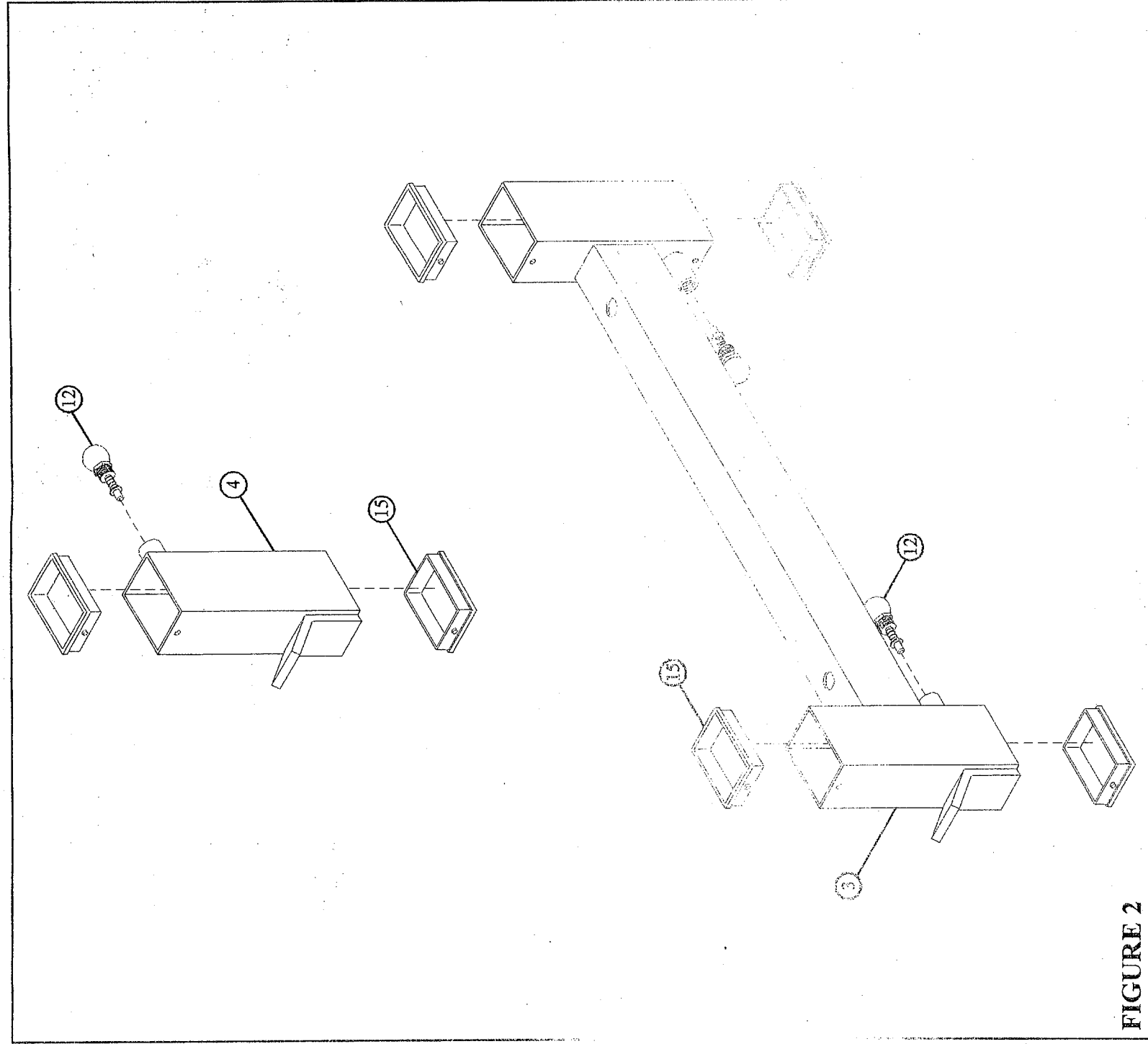

FIGURE 2

STEP 2:

- Insert twelve 3 X 2" INSERT GUIDES (15) into the ends of each SAFETY RAIL (3) and BAR SUPPORT (4) as shown in FIGURE 2. (NOTE: Make sure the INSERT GUIDES (15) snap into the holes of the weldments.)
- SECURELY assemble the six SPRING PIN ASSEMBLIES (12) to the SPRING PIN BARRELS on each SAFETY RAIL (3) and each BAR SUPPORT (4) as shown in FIGURE 2.

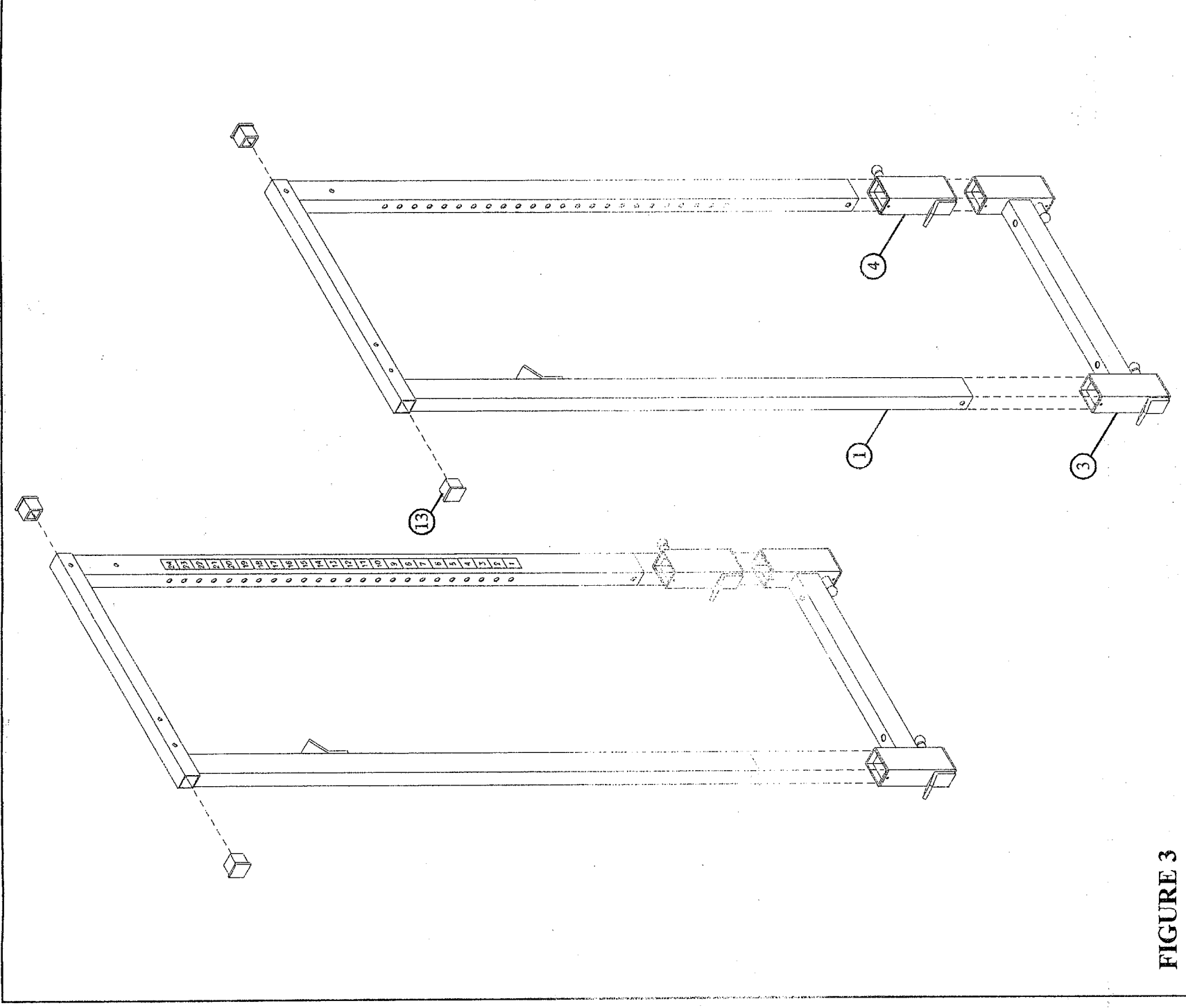
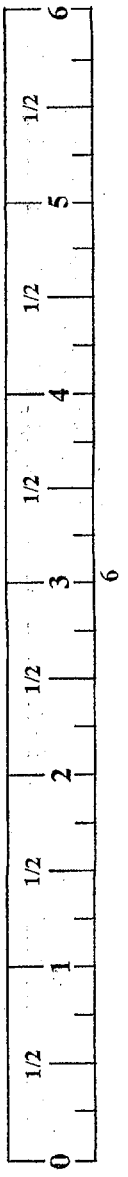

FIGURE 3

STEP 3

- Insert four 2" SQ END CAPS (13) into the ends of the UPRIGHTS (1) as shown in FIGURE 3.
- Slide one BAR SUPPORT (4) and one SAFETY RAIL (3) (IN THAT ORDER) onto each UPRIGHT (1). Pull back on the SPRING PIN ASSEMBLIES until they pop into holes.