



**Remote Arming Module V1.10
318MHz/433MHz**

With *KEELOQ* high-security code encryption



Installer's Guide

P ▲ R ▲ D O X
S E C U R I T Y S Y S T E M S
780 Industrial Blvd, St-Eustache, Montreal, Quebec, Canada J7R 5V3
Fax: (450) 491-2313 <http://www.paradox.ca>

PRINTED IN CANADA - 11/98



P ▲ R ▲ D O X
S E C U R I T Y S Y S T E M S

PARKEI-02

TABLE OF CONTENTS

INTRODUCTION	2
1.1 Features	2
1.2 Technical Specifications	3
INSTALLATION	4
2.1 Location & Mounting	4
2.2 Power & Communication	4
2.2.1 With Esprit Control Panel	4
2.2.2 Stand Alone	5
2.3 Keypad	5
2.4 Antenna	6
2.5 Programmable Outputs (PGMs)	6
2.6 Hand-Held Remote Control	7
2.7 System Reset	8
HOW TO PROGRAM	11
PROGRAMMING THE SYSTEM	13
4.1 Access Code Length	13
4.2 Installer Code	13
4.3 User Parameters	13
4.3.1 User Access Codes	14
4.3.2 Remote Control Assignment	15
4.3.3 Remote Control Options	16
4.4 Panic Output Programming	17
4.5 Panic Lockout Timer	18
4.6 PGM Output Timing	18
4.7 Button PGM Options	19
4.8 Panic Option	20

INTRODUCTION

The **PARAKEY** is a wireless remote control system that consists of a receiving module and up to eight 2 or 4-button remote controls (transmitters). When used in conjunction with any *Paradox Esprit Series Control Panel*, remote controls can perform actions such as remote arming and disarming, communicating panic alarms and/or activating programmable outputs (PGMs). Each remote control is assigned to a specific user and therefore, identifies the user to the control panel when used. If desired, it can be used as a stand-alone system where the remote controls will only activate the on-board PGM outputs. When a button on the remote control is pressed, it will transmit an RF signal. When the **PARAKEY** receives this signal, it then processes the request and performs the programmed action(s).

1.1 Features

- Simple, user-friendly programming.
- Supports 8 User Codes, each linked to a unique RF Code (2 or 4-button remote control).
- Encrypted RF codes for additional security. Does not use DIP switch programming.
- 4 programmable outputs (PGMs).
- Stand-alone operation (trigger PGMs only) or in conjunction with a *Paradox Esprit Series Control Panel* (arm/disarm, panic & PGM activation).
- Programming keypad connects directly to the Parakey Receiving Module.
- Programmable Installer Code.
- Software reset.

1.2 Technical Specifications

1.2.1 Receiver:

Compatible Programming Keypads:	(616 V4.2A & up) (626 V4.1A & up)
DC input:	12VDC
PGM outputs:	4
PGM Output 1-3 Current Rating:	30mA max.
PGM Output 4 Current Rating:	5A relay
Max Transmission Range:	53.34m (175 ft.)
Operating Conditions:	0°C to 50°C
Operating Humidity:	85%
Operating Frequency:	318 or 433.92MHz
Sensitivity:	-110dbm

1.2.2 Remote Control:

Water Resistant	
Battery:	Lithium 3V (CR2032)
Battery Life:	Apprx. 2 years
Power Transmission:	7mW
Current Consumption:	6mA (transmission)

INSTALLATION

2.1 Location & Mounting

We recommend installing the receiver in a centralized location on the main floor. Avoid installing the receiver in the basement. Although, if desired, it can be installed in proximity of the control panel. When selecting an installation site please take into consideration that the maximum reception distance of the receiver is approximately 54 meters (175 feet) line of sight. The circuit is static sensitive, thus take great care during handling.



Avoid installing the receiving module near or in the path of strong RF fields, such as neon lights or computers. Also avoid installing the receiver on or near metal objects, circuit breaker boxes, air conditioners and heater ducts. These devices may cause interference, reducing the receiver's sensitivity.

If installing the Parakey away from the control panel, mount the Parakey Receiver Module on a wall, leaving at least 2" around the panel box to permit adequate ventilation/heat dissipation. Selecting a site that is not susceptible to drastic changes in temperature and humidity.

2.2 Power & Communication

2.2.1 With Esprit Control Panel

When used in conjunction with any *Paradox Esprit Series Control Panel*, the auxiliary terminals (12Vdc) of the

control panel may power the Parakey Receiving Module as shown in figure 3. If using an external power source please ensure that the "GND" of the receiver and the power source are connected to the "AUX-" terminal of the control panel.

The "GRN" and "YEL" terminals of the control panel must be connected to the "GRN" and "YEL" terminals of the Parakey Receiving Module in order to provide communication between the modules. Alternatively, you can use a 4-pin serial connector between the control panel's "SERVICE KEYPAD" connector and the Parakey Module's "PANEL" connector.

2.2.2 Stand Alone

When used as a stand-alone system, you will need a *Paradox 12Vdc 801 Power Supply* and a 12Vdc backup battery. Connect the power supply and the backup battery as shown in figure 4.

2.3 Keypad

The Parakey Receiving Module is programmed using a 616 or 626 Esprit LED Keypad. Connect the keypad as shown in figure 3 or 4. Alternatively, you can connect the keypad to the Parakey Module's "PROGRAM" connector using a 4-pin serial connector.



*The Parakey can only be programmed using:
616 keypad version 4.2A and up or
626 keypad version 4.1A and up.*

2.4 Antenna

Firmly screw the vertical and horizontal antennas to the corresponding "ANT" connections on the Receiving Module as shown in figure 3 or 4. Use of the horizontal antenna is optional, but is recommended for best results.



Do not cut, bend or alter the antenna in any way, as this may reduce the receiver's sensitivity (range).

2.5 Programmable Outputs (PGMs)

The Parakey provides four programmable outputs (OUT1 to OUT4) each of which can be programmed for a variety of home/office automation applications, such as opening a garage door when button 1 is pressed on the remote control. Please refer to figure 1 and section 4 for more information.

Figure 1: PGM Outputs

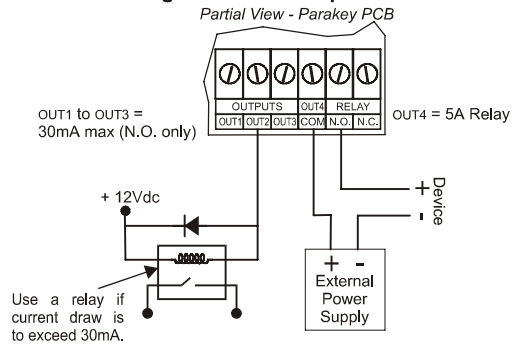

2.6 Hand-Held Remote Control

There are two types of hand-held **PARAKEY** remote controls. There is a 2-button RF transmitter and a 4-button RF transmitter. Each button can perform different actions depending on how the system is programmed. These remote controls can transmit a signal up to a maximum of 54 meters (175ft). The remote controls are powered by a 3V lithium battery. Occasionally this battery must be changed as shown in figure 2. References to button 3 and button 4 indicate keys on the 4-button remote control only.

Figure 2: Remote Control

If the Panic option is enabled (see key [B] in section 4.3.3), simultaneously press buttons 1 and 2 to activate a panic alarm.

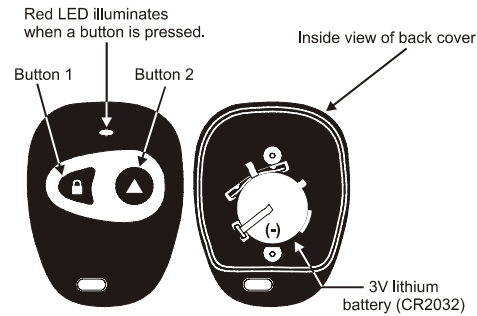

To replace the battery:

- 1) Remove the two screws from the back of the remote control.
- 2) Remove the back cover.
- 3) Remove the old battery from inside the back cover as shown above.
- 4) Replace with a new 3V lithium battery (CR2032) verifying proper polarity. The positive of the battery is inserted face down.

2.7 System Reset

Performing a system reset will set the Parakey to default settings. Please note that if connected to a control panel, the reset sequence of the Parakey will **not** cause the control panel to reset and vice versa. To execute a system reset perform the following:

- 1) Remove the power connections (" +12" & "GND") from the receiver.
- 2) Press and hold the "PROG" button and re-connect the power connections to the receiver.
- 3) Wait approximately 2 seconds and release the "PROG" button. The red LED will flash for 15 seconds, the keypad will beep, and all system settings will be reset to factory default.

Figure 3 - Connection with Control Panel

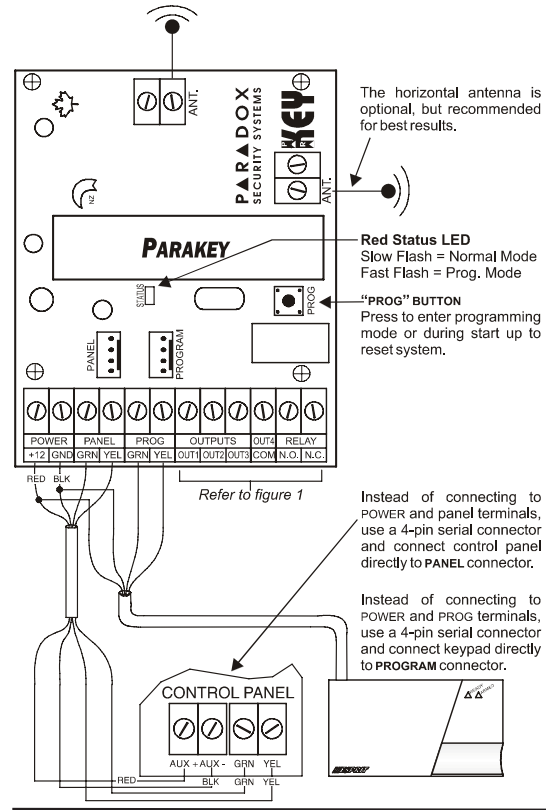
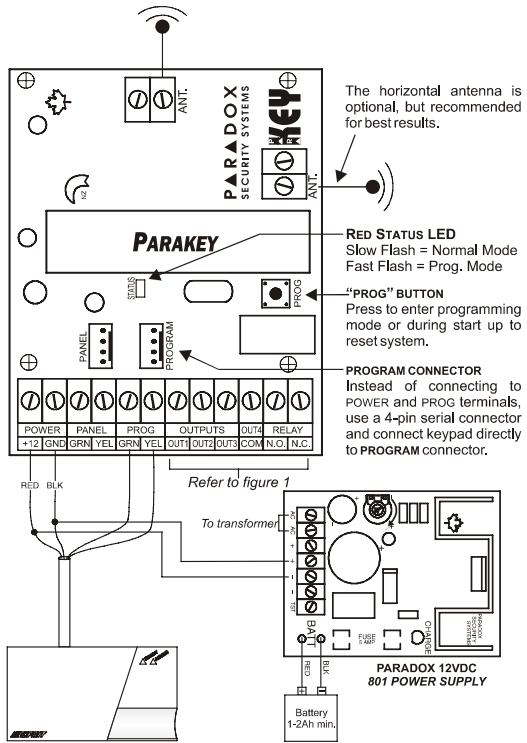

Figure 4: Stand-Alone Connection



HOW TO PROGRAM

Press the [CLEAR] key at any time to revert to the preceding step, unless entering data, in which case you will remain in the section and the current data entry will be erased.

3.1.1 Step 1 - Enter the Programming Mode

When in "Normal Mode", the red LED on the Parakey Receiver flashes on and off at 2-second intervals. To enter the Programming Mode, press the "PROG" button located on the Parakey Receiver. The program keypad will beep once, the red LED will flash and the keypad's "READY" light will illuminate.



If at any time you wait longer than 2 minutes between each key entry, the Parakey will automatically exit the Programming Mode.

3.1.2 Step 2 - Key in Installer Code

Press [ENTER] and key in the [INSTALLER CODE]. The [ENTER] key will flash. Default installer code: **[757575]**

3.1.3 Step 3 - Key in Desired Section

Key in the desired 2-digit [SECTION] you wish to program. The [ENTER] key will remain illuminated. The [2ND] key will flash if the current section is empty. Pressing the [2ND] key followed by the [ENTER] key will clear the contents of the current section.

3.1.4 Step 4 - Key in the required data

- Sections [00] - [08]
Access Code Programming - Use any digits from 0 to 9 to enter the desired access code. When the

required data is entered, the keypad will emit a confirmation beep and the Parakey will automatically save and exit the section. If you make a mistake, pressing [CLEAR] when entering data will erase the current entry. Return to step 3 or press [CLEAR] to exit Programming Mode.

- Sections [09] to [16]
RF Programming - Press the [ENTER] key and press button 1 twice on the remote control to assign remote control to corresponding user. The keypad will emit a confirmation beep and the Parakey will save and exit the section. Return to step 3 or press [CLEAR] to exit Programming Mode.
- Sections [25] - [30]
Decimal Select - Each section represents one feature and each key from [0] to [8] represents a specific setting. Unlike feature select programming, only one key can be selected. The selected key will remain illuminated. Press the key representing the desired setting and press [ENTER].
- Sections [17] - [24] & [31] - [35]
Feature Select - After entering the section, each key from [1] to [8] represents a feature or option. The on/off status of these keys determines the feature's setting. Turn the keys on/off by pressing the appropriate key until the desired options are set and press the [ENTER] key. The keypad will emit a confirmation beep and the Parakey will save and exit the section. Return to step 3 or press [CLEAR] to exit Programming Mode.

PROGRAMMING THE SYSTEM

4.1 Access Code Length

Section [35] - Feature Select Programming: [1]

The Parakey can be set to accept 6-digit or 4-digit User and Installer Access Codes.

Key [1] OFF = 4-digit access codes.

Key [1] ON = 6-digit access codes (default).



This option must be set to the same access code length as set in the control panel at address 088, key [9].

4.2 Installer Code (Default: 757575)

Section [00] - Access Code Programming

The Installer Code provides you with access to program all the functions & features of the Parakey System. The Installer Code can be 4 or 6 digits in length (see section 4.1) with each digit being any value from 0 to 9.

4.3 User Parameters

The Parakey system supports up to eight users, each with a different remote control. As demonstrated in figure 5, the three parameters listed below are specific to each user and each user must be defined with all three of these parameters.

- User Access Code
- Remote Control Assignment
- User Remote Control Options

Figure 5: Programming User Parameters

- Step 1: Enter *Programming Mode* by pressing the “PROG” button located on the Parakey receiver.
- Step 2: Press the [ENTER] key and key in the [INSTALLER CODE] (default: 757575)
- Step 3: Key in the desired 2-digit [SECTION] and the required [DATA] as indicated by the table below.

User#	SECTION #'s		
	User Access Code	Remote Control Assignment	Remote Control Options
1	[01]	[09]	[17]
2	[02]	[10]	[18]
3	[03]	[11]	[19]
4	[04]	[12]	[20]
5	[05]	[13]	[21]
6	[06]	[14]	[22]
7	[07]	[15]	[23]
8	[08]	[16]	[24]

Refer to section 4.3.1. Refer to section 4.3.2. Refer to section 4.3.3.

The above table demonstrates which three sections must be programmed for each of the 8 users.

4.3.1 User Access Codes

Sections [01] to [08] - Access Code Programming

When a user presses a button, the Parakey determines which user the remote control belongs to and transmits the corresponding User Access Code to the control panel. To arm/disarm the system, the *Paradox Esprit Series Control Panel* must receive a valid access code. Therefore, the

programmed User Access Code must be the same as a User Access Code programmed in the *Paradox Esprit Series Control Panel*. If no access code is programmed, only the programmed PGMs will be activated. The User Access Codes can be 4 or 6 digits in length (see section 4.1) with each digit being any value from 0 to 9. Program the User Access Code into the section corresponding to the desired user, where sections [01] to [08] represent users 1 through 8 respectively (figure 5).



The User Access Code programmed in the Parakey must be the same as a User Access Code programmed in the *Paradox Esprit Series Control Panel*.

4.3.2 Remote Control Assignment

Sections [09] to [16] - RF Programming

Every time a button is pressed on the remote control, it transmits its RF code to the Parakey, identifying it as a user in the system. Therefore, each remote control in the system must be assigned to a user. After entering the section corresponding to the desired user (see figure 5), press the [ENTER] key and the “READY” and “ARM” lights will illuminate. Then press button 1 on the remote control once, the Parakey will beep once. Press button 1 again for confirmation, the Parakey will beep twice to indicate that the remote control was successfully assigned. One long beep indicates that remote control assignment was unsuccessful (i.e. remote control already assigned to another user). To delete a remote control, enter the desired section, press the [2ND] key and press the [ENTER] key.

4.3.3 Remote Control Options

Sections [17] to [24] - Feature Select: [1] to [8]

As described in figure 5, sections [17] to [24] correspond to users 1 through 8 respectively. By turning keys [1] to [8] on or off, set the desired remote control options as described below and press [ENTER].

Buttons 1 and 2 on the remote controls can be set to perform different arming and disarming actions when pressed, depending on the setting of keys [1] to [3] as shown in the table below. (Default: Button 1 = Regular Arming)

Key [1]	Key [2]	Key [3]	Description
Off	Off	Off	No Arming & Disarming
On	Off	Off	Button 1 = Regular Arming
Off	On	Off	Button 2 = Regular Arming
On	On	Off	Button 1 = Regular Arming Button 2 = Regular Arming
Off	Off	On	Button 1 = Away Arming
On	Off	On	Button 1 = Away Arming Button 2 = Stay Arming
Off	On	On	Button 1 = Regular Arming Button 2 = Stay Arming
On	On	On	Button 1 = Stay Arming

Each key from [4] to [7] represents buttons 1 through 4 respectively. When the key is enabled, pressing the corresponding button will activate (toggle) any PGMs defined by the *Button PGM Options* (section 4.7). Default all ON.

Key [4] OFF = Disabled
ON = Button 1 PGM Enabled

Key [5] OFF = Disabled
ON = Button 2 PGM Enabled

Key [6] OFF = Disabled
ON = Button 3 PGM Enabled (*4-button remote only*)

Key [7] OFF = Disabled
ON = Button 4 PGM Enabled (*4-button remote only*)

When the [8] key is enabled, pressing any two buttons simultaneously on the remote control will generate a panic alarm (see sections 4.4, 4.5 and 4.8)

Key [8] OFF = Panic Disabled
ON = Panic Enabled (Default)

4.4 Panic Output Programming

Section [25] - Decimal Select: [0] to [4]

When a remote control-activated panic alarm is generated (see section 4.3.3), the Parakey can activate one of the four on-board PGM outputs. In section [25], select only one:

Section [25]

- Key [0] ON = No output on panic alarm
- Key [1] ON = Toggle output 1 on panic alarm
- Key [2] ON = Toggle output 2 on panic alarm
- Key [3] ON = Toggle output 3 on panic alarm (default)
- Key [4] ON = Toggle output 4 on panic alarm

4.5 Panic Lockout Timer

Section [26] - Decimal Select: [0] to [4]

When a remote control-activated panic alarm is generated (see section 4.3.3), the Parakey can ignore any incoming RF signals for a specified period. This prevents an aggressor from disarming the system in case of a panic situation. In section [26], select only one:

Section [26]

- Key [0] ON = No signal lock-out on panic alarm (default)
- Key [1] ON = 30 second signal lockout on panic alarm
- Key [2] ON = 60 second signal lockout on panic alarm
- Key [3] ON = 90 second signal lockout on panic alarm
- Key [4] ON = 120 second signal lockout on panic alarm

4.6 PGM Output Timing

Section [27] to [30] - Decimal Select: [0] to [8]

When any of the PGM outputs are activated (see section 4.3.3 & 4.4), the Parakey can latch the output in its opposite state until the output is toggled again or for a specified period of time. At the end of this period, the output will return to its normal state. Each PGM output

can be programmed with a separate output timer. In the section corresponding to the desired PGM output, where sections [27] to [30] represent PGM outputs 1 through 4 respectively, select the desired output timer.

- | | |
|-------------------------------|----------------------|
| Key [0] ON = Latched | Key [5] ON = 40 sec. |
| Key [1] ON = 1 sec. | Key [6] ON = 60 sec. |
| Key [2] ON = 5 sec. (default) | Key [7] ON = 2 min. |
| Key [3] ON = 10 sec. | Key [8] ON = 4 min. |
| Key [4] ON = 20 sec. | |

4.7 Button PGM Options

Sections [31] to [34] - Feature Select: [1] to [4]

This feature allows you to determine which PGM outputs a PGM enabled button will activate (see section 4.3.3).



Please note that this feature is a global feature. For example, if button 1 is programmed to toggle PGM outputs 1 and 2, then button 1 on all the remote controls will toggle PGM outputs 1 and 2.

In the section corresponding to the desired button, where sections [31] to [34] represent buttons 1 through 4 respectively, select which outputs will be triggered.

- | OFF | Key | ON |
|----------|-----|-------------------|
| Disabled | [1] | Activate Output 1 |
| Disabled | [2] | Activate Output 2 |
| Disabled | [3] | Activate Output 3 |
| Disabled | [4] | Activate Output 4 |

4.8 Panic Option

Section [35] - Feature Select: [2]

When a remote control-activated panic alarm is generated (see section 4.3.3), the Parakey can perform one of two actions:

Key **[2]** OFF = Panics generated from the remote control will only toggle the enabled PGM output (see section 4.4).

Key **[2]** ON = Panics generated from the remote control will toggle any enabled PGM outputs (see section 4.4) and sends the Panic command to the control panel generating a Panic alarm on the control panel.

Warranty

The Seller warrants its products to be free from defects in materials and workmanship under normal use for a period of one year. Except as specifically stated herein, all express or implied warranties whatsoever, statutory or otherwise, including without limitation, any implied warranty of merchantability and fitness for a particular purpose, are expressly excluded. Because Seller does not install or connect the products and because the products may be used in conjunction with products not manufactured by Seller. Seller cannot guarantee the performance of the security system. Seller obligation and liability under this warranty is expressly limited to repairing or replacing, at Seller's option, any product not meeting the specifications. In no event shall the Seller be liable to the buyer or any other person for any loss or damages whether direct or indirect or consequential or incidental, including without limitation, any damages for lost profits stolen goods, or claims by any other party, caused by defective goods or otherwise arising from the improper, incorrect or otherwise faulty installation or use of the merchandise sold.

FCC Warnings

This device complies with part 15 of the FCC Rules. Operation is subject to the following two conditions: (1) this device may not cause interference, and (2) this device must accept any interference, including interference that may cause undesired operation of the device.