



Included Items:

- 1 strobe lens (available in red, blue, amber, or clear)
- 3 type “D” alkaline batteries

Required/Optional Items:

- Mounting hardware
- 8-16Vac, or 9-20Vdc external power supply (optional)

Compatibility:

- MG/SP series V4.0 (EVO coming soon)
- MG6130/MG6160 V3.0
- RTX3 V1.5
- K32LCD V1.3
- WinLoad V4.7 (with In-Field Upgrade Software V2.3)
- For latest updates visit paradox.com

Description

The SR150 is a weatherproof, stand-alone, and fully supervised wireless siren with built-in strobe light and wireless transceiver.

The SR150 operates using 3 size “D” alkaline batteries. With normal use, the SR150 will function up to 3 years without the need to replace the batteries (battery life can be extended by using an optional AC or DC power supply).

The SR150 uses 2-way wireless communication, which provides continuous supervision between the panel and siren with fast response to alarm signals of up to 4 seconds.

With its tough weatherproof construction, the SR150 will operate reliably from -30°C to 50°C (-22°F to 122°F) when using alkaline batteries or power supply.

Features

- Internal protective plastic cover (see A below)
- Built-in transceiver (see D below)
- 100db wireless siren (see 1 below)
- Integrated strobe light (see E below)
- Weather-resistant design using a PC/ABS enclosure with UV protection and a silicone coated PCB
- Fast alarm response time (4 seconds)
- 2.5 hour alarm display (strobe flashes every 4 seconds after bell cut-off)
- Siren presence supervised by control panel
- Panel presence supervised by siren (activates siren and strobe for 5 minutes if communication is lost)
- Triple tamper protection for screw removal, cover removal, and removal from wall (see 5 and 6 below)
- Assign up to 4 sirens per control panel
- Firmware upgradeable via 307USB (see 4 below)
- Siren test mode

Overview

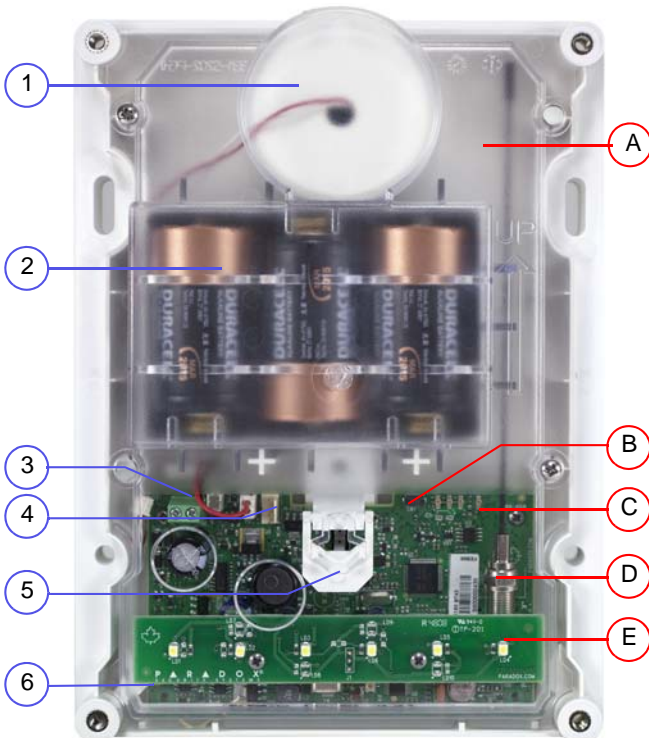

- 1) 100dB siren
- 2) Battery pack (3 size “D” alkaline batteries) with gold plated battery connections, or optional 3.6Vdc
- 3) Power supply input (8-16Vac / 9-20Vdc)
- 4) In-field firmware upgrade connector
- 5) Dual-action tamper switch (detects when cover is removed and when unit is removed from wall)
- 6) Tamper switch (detects screw removal)

- A) Internal protective plastic cover
- B) Test switch
- C) Status and Signal Strength LEDs. Refer to LED Feedback on reverse for more information.
- D) Built-in wireless transceiver (433MHz or 868MHz) provides full supervision. See reverse side for more information.
- E) Strobe lights

Note: This equipment has been tested and found to comply with the limits for a Class B digital device, pursuant to part 15 of the FCC Rules. These limits are designed to provide reasonable protection against harmful interference in a residential installation. This equipment generates, uses and can radiate radio frequency energy and, if not installed and used in accordance with the instructions, may cause harmful interference to radio communications. However, there is no guarantee that interference will not occur in a particular installation. If this equipment does cause harmful interference to radio or television reception, which can be determined by turning the equipment off and on, the user is encouraged to try to correct the interference by one or more of the following measures:

- Reorient or relocate the receiving antenna.
- Increase the separation between the equipment and receiver.
- Connect the equipment into an outlet on a circuit different from that to which the receiver is connected.
- Consult the dealer or an experienced radio/TV technician for help.

LED Feedback

		Remove cover to view LED status
TX	Sending data	
RX	Receiving data	
PSSI	Signal strength siren is receiving from panel Flash 4x - strong signal Flash 3x - good signal Flash 2x - weak signal Flash 1x - very weak signal (relocate) No flash - no signal	
Status	Flash once/sec. - Processor is on Flash once/4 sec. - Power save mode	

Specifications

Power	4.5Vdc (3 size "D" alkaline batteries) Optional: 8-16Vac / 9-20Vdc external power
Battery life	Up to 3 years based on normal use (e.g. 2 alarms per year with strobe for 2.5 hours and 8 squawks per day at an average of 25°C (77°F)). Using optional power source will extend battery life.
Consumption	Sleep: 22uA, Standby: 130uA, Alarm: 550mA
RF frequency	433MHz or 868MHz
Siren	100dB (1 meter)
Dimensions	24cm X 6.cm X 18cm (9.5in X 2.3in X 7in)
Operating Temperature	Battery only: -30°C to 50°C (-22°F to 122°F)
RF range	70m (229ft)

Programming

MG/SP	Feature	Details
[683]	Learn Siren #1	Press and hold "TEST" switch for 3 seconds after entering the section to learn the siren. Warning: When you press the "TEST" switch, the SR150 will squawk and the strobe light will flash five times to confirm registration to the panel.
[684]	Learn Siren #2	
[685]	Learn Siren #3	
[686]	Learn Siren #4	
[687]	Display Signal Strength Siren #1	Press and hold "Test" switch for 3 seconds after entering the section to display, on a K32LCD V1.3 or higher, the signal strength the panel is receiving from the siren.
[688]	Display Signal Strength Siren #2	
[689]	Display Signal Strength Siren #3	
[690]	Display Signal Strength Siren #4	
[691]	Label Siren #1	These labels are used when reporting events via e-mail through the IP100 and for troubleshooting purposes. Maximum 16 characters.
[692]	Label Siren #2	
[693]	Label Siren #3	
[694]	Label Siren #4	
[695]	Temporary Tamper Switch Deactivation for Maintenance	Press the [ENTER] key after entering the section to deactivate tamper alarm until the cover is replaced or after 30 minutes.
[587]	Panel Supervision of Siren	OFF = disabled ON = enabled (default)
Option [3]	Siren #1 (OFF/ON)	The control panel supervises the presence of the SR150. If lost, the control panel will follow global supervision loss option set in the panel.
Option [4]	Siren #2 (OFF/ON)	
Option [5]	Siren #3 (OFF/ON)	
Option [6]	Siren #4 (OFF/ON)	

Upgrading the Firmware

The SR150 firmware can be upgraded through WinLoad using the 307USB Direct Connect Interface. Refer to the firmware upgrade instructions found at: paradox.com - Software - WinLoad -Firmware Upgrade Instructions.

NOTE: Ensure that the SR150 Wireless Siren is awake before beginning the firmware upgrade. To wake up the siren, press the "test" button. The siren will provide you with a 60 second delay in order to begin the update.

Siren Supervises Panel/RTX3

The SR150 supervises the control panel and the RTX3 every 12 minutes (with external power supply) or every 25 minutes (with battery power only). If after 3 attempts SR150 Wireless does not receive a response, the siren will squawk every 4 seconds and the strobe light will flash every 4 second for a period of 5 minutes. When this occurs, the siren/strobe can be stopped by pressing the disarm button on any of the first 10 remotes assigned to the system.

Tamper Supervision

If a tamper is detected, the SR150 will sound an alarm and the strobe light will flash for 4 minutes. The control panel will follow the global supervision options set in the panel.

For complete warranty information, please visit www.paradox.com/terms. Your use of the Paradox product signifies your acceptance of all warranty terms and conditions. Magellan, Spectra SP, EVO, and WinLoad are trademarks or registered trademarks of Paradox Security Systems Ltd. or its affiliates in Canada, the United States and/or other countries. For the latest product approvals, such as UL and CE, please visit www.paradox.com. © 2009 Paradox Security Systems Ltd. All rights reserved. Specifications may change without prior notice. One or more of the following US patents may apply: 7046142, 6215399, 6111256, 6104319, 5920259, 5886632, 5721542, 5287111, 5119069, 5077549 and RE39406 and other pending patents may apply. Canadian and international patents may also apply. Changes or modifications not expressly approved by the party responsible for compliance could void the user's authority to operate the equipment.