

9109 OCU-DP Application Module (APM) Installation Instructions

Document Number 9109-A2-GN15-10

May 1999

Product Documentation on the World Wide Web

We provide complete product documentation online. This lets you search the documentation for specific topics and print only what you need, reducing the waste of surplus printing. It also helps us maintain competitive prices for our products.

Complete documentation for this product is available at **www.paradyne.com**.
Select *Library* → *Technical Manuals* → *NextEDGE Multiservices Access System*.

Select the following document:

9191-A2-GH30

NextEDGE Multiservices Access System Technical Reference

To request a paper copy of a Paradyne document:

- Within the U.S.A., call 1-800-PARADYNE (1-800-727-2396)
- Outside the U.S.A., call 1-727-530-8623

Before You Begin

Make sure you have:

- The housing, and any associated hardware already installed
- A T1 NAM already installed in Slot 01 and connected to the network
- Applicable cables
- A small Phillips screwdriver (#1 or #2) to install the APM
- A small, flat-blade screwdriver to install the I/O card and cable connections

See the Technical Reference for additional information on:

- *Troubleshooting*
- *Technical Specifications*
- *Cables, Connectors, and Pin Assignments*

Package Checklist

Verify that your package contains the following:

- OCU-DP APM
- OCU-DP I/O card

When your equipment arrives, inspect it for physical damage and tighten any screws that may have worked loose. Contact your sales representative immediately if there are any signs of shipping damage or if anything is missing from your package. Otherwise, proceed with the installation.

Equipment You May Need to Order

A DDS Network cable must be ordered for this product (either the 14 ft., Feature No. 3600F3-501, or 25 ft., Feature No. 3600-F3-502).

NOTE:

The following NAM I/O versions are required to use the OCU-DP APM:

- The SINGLE T1 NAM for Model 9161
- The DUAL T1 NAM for Model 9261

HANDLING PRECAUTIONS FOR STATIC-SENSITIVE DEVICES

This product is designed to protect sensitive components from damage due to electrostatic discharge (ESD) during normal operation. When performing installation procedures, however, take proper static control precautions to prevent damage to equipment. If you are not sure of the proper static control precautions, contact your nearest sales or service representative.



Installing the I/O Card

The I/O card provides the APM with DDS connections. The I/O card inserts directly behind the APM that it supports. Slot numbers are identical to facilitate correct installation.

NOTE:

For the 2-port OCU-DP APM, only Port 1 and Port 2 on the I/O card are functional.

- 1. Remove the I/O card from the shipping box. Handle only by the top and bottom edges to avoid damaging the card.
- 2. At the rear of the housing, align the I/O card with the upper and lower tracks of the slot. Push gently towards the midplane until it stops and you cannot push the card any further.

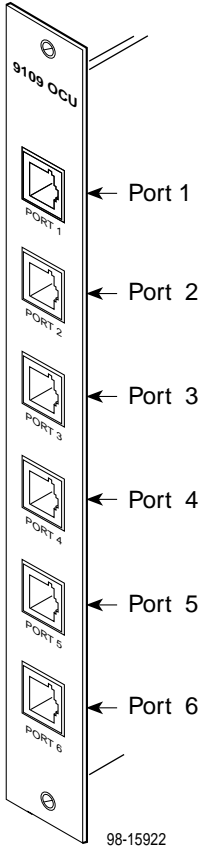
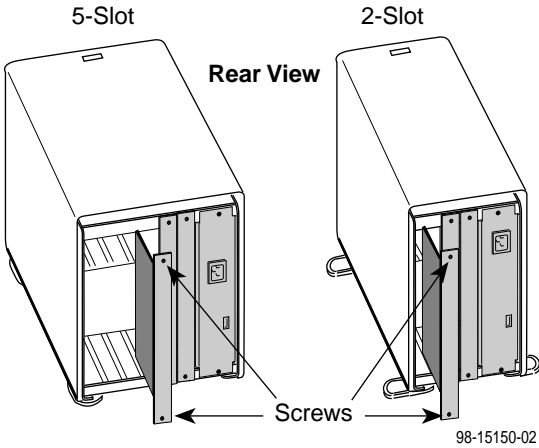

- 3. There are two captive screws on the I/O card. Alternately tighten each screw until both are snug.

Connecting to the DDS Interface

1. Insert the RJ48S DDS network cable into the 4-wire DDS port. The 2-port version provides two RJ48S, 8-position modular keyed jacks, while the 6-port version provides six.
2. Insert the other end of the cable into the DSU/CSU.

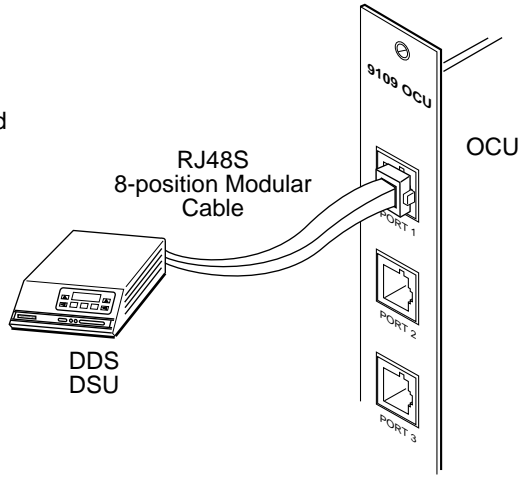

Removing the Housing's Bezel

1. Depress the latch at the top of the housing to open the bezel.
2. Lift upward to remove the bezel from the two slots at the bottom of the housing.

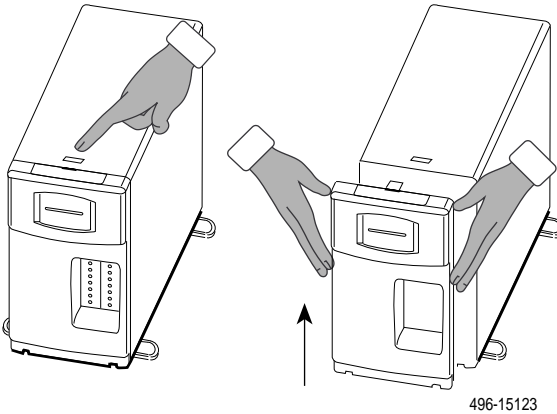

Save the bezel so it can be reattached once the APM has been installed.

NOTE:

The power supply is visible once the bezel is removed. It provides low voltage power to the housing and its cards.

WARNING:

If you need to remove the power supply module, you *must* unplug the power cord from the power receptacle and from the rear of the housing before attempting to remove the module.

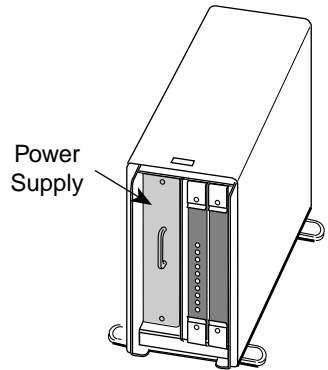

Front View
(without Bezel)

98-15174-01

Installing the APM

The APM can be installed in any slot *except* Slot 01.

CAUTION:

You must insert the OCU-DP APM in the correct slot so that it mates with its matching I/O card. APMs are keyed so that they mate only with their matching I/O cards.

1. Remove the filler panel, if applicable. See the installation instructions that came with your housing for information.
2. Remove the APM from the shipping box. Handle only by the top and bottom edges to avoid damaging the card.
3. At the front of the housing, align the APM with the upper and lower tracks of the selected slot.

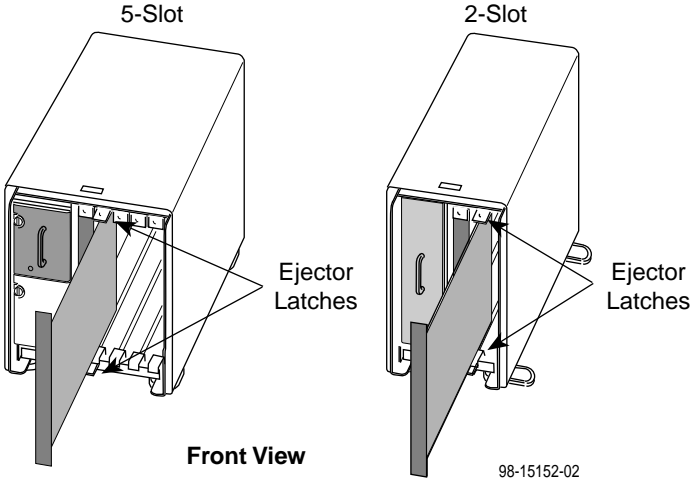

4. Slide the APM into the tracks until it seats with the midplane connectors. Be careful not to force the card or bend any pins.
5. Close both the upper and lower ejector latches on the housing to lock in place, then tighten the captive screws on the ejector latches.

Removing/Replacing a Card

Card removal procedures differ, depending on whether you are removing the APM or I/O card.

NOTE:

You can insert or remove the APM and its associated I/O card without powering off the equipment and interrupting data flow through other cards in the network.

Removing/Replacing an APM

1. Remove the housing's bezel, if applicable. See the installation instructions that came with your housing for information.
2. Remove the captive screws from the ejector latches on the front of the housing.
3. Press open the ejector latches to disengage the card from the midplane.
4. Supporting the card by its edges, pull straight out until the card clears the housing.
5. Refer to Steps 3–5 of *Installing the APM* on page 6.

If the slot . . .	Then the . . .
Was previously unassigned	Configuration settings are the factory defaults and are accessible from SNMP and the user interface.
Was previously assigned to the same type of APM	Existing configuration settings are used and are accessible from SNMP and the user interface.
Previously contained a different type of APM	System generates a Module Misconfiguration alarm for the given slot. See the Technical Reference for procedures in this situation.

Removing/Replacing an I/O Card

1. Remove the APM from the housing (see *Removing/Replacing an APM*).
2. Remove the cables from the I/O card.
3. Using a screwdriver, loosen the upper and lower captive screws fastening the card to the housing's frame.
4. Gently pull the I/O card away from the midplane until it clears the housing.
5. Align the replacement card with the upper and lower tracks of the slot. Push gently towards the midplane until it stops and you cannot push the card any further.

-
6. Alternately tighten each captive screw until both are snug.
 7. Reattach the cables as appropriate.

Power-On

Refer to the installation instructions that came with your housing to power on the equipment.

Warranty, Sales, Service, and Training Information

Contact your local sales representative, service representative, or distributor directly for any help needed. For additional information concerning warranty, sales, service, repair, installation, documentation, training, distributor locations, or Paradyne worldwide office locations, use one of the following methods:

- **Internet:** Visit the Paradyne World Wide Web site at **www.paradyne.com**. (Be sure to register your warranty there. Select *Service & Support* → *Warranty Registration*.)
- **Telephone:** Call our automated system to receive current information by fax or to speak with a company representative.
 - Within the U.S.A., call 1-800-870-2221
 - Outside the U.S.A., call 1-727-530-2340

Document Feedback

We welcome your comments and suggestions about this document. Please mail them to Technical Publications, Paradyne Corporation, 8545 126th Ave. N., Largo, FL 33773, or send e-mail to **userdoc@eng.paradyne.com**. Include the number and title of this document in your correspondence. Please include your name and phone number if you are willing to provide additional clarification.

Trademarks

All products and services mentioned herein are the trademarks, service marks, registered trademarks or registered service marks of their respective owners.



9109-A2-GN15-10