

## 200 Series Radio Module Integration Guide

### 1. Overview

The 200 Series Radio Module is an OEM device used to acquire data from LORD Corporation wireless sensing devices. It is designed to be embedded in other products to provide radio communication and data pass-through capabilities in a modular format. It is designed to be used with LORD data acquisition software or user software developed using the LORD MSCL code library.

The module includes an integrated microcontroller/radio transceiver that communicates to LORD devices in the 2.4 GHz band. There are two radio transmission protocols that are available on the radio module – the standard 802.15.4 protocol (LXRS) and a LORD proprietary protocol (LXRS+). The modes are selectable in the LORD software. Both are capable of lossless transmission of continuous, burst, and other sampling modes, depending on the node capabilities. The increased radio transmission rate of the LXRS+ protocol results in faster network throughput, and the ability to handle larger data packets. However, because of the increased packet size, the packet error rate will likely increase (reducing RF sensitivity) and effectively reducing the RF range.

### 2. Integration

The radio module requires a PCB carrier board for proper integration. This board can be designed by LORD, or by an OEM customer with the information provided in this document. The carrier board provides power (+5 Vdc +/- 2%, 50mA) to the radio module, as well as the serial and input/output interface to connect the microcontroller to the larger communication system. The microcontroller code required to control the radio module is proprietary and is developed at LORD.

The following section describes physical layout and pin configuration of the module. The module is 0.98" x 0.53". It has an internal antenna on one end of the board. The interface to the carrier board is through solder pads around the three other sides of the board. For exact layout dimension of these pads, contact LORD Technical Support for an engineering file.

The radio module is an OEM circuit board intended to be housed in an enclosure of the type suitable for the final product. It has no environmental protection by itself. Operating temperature range is -40 to +85 °C.

Physical Interface

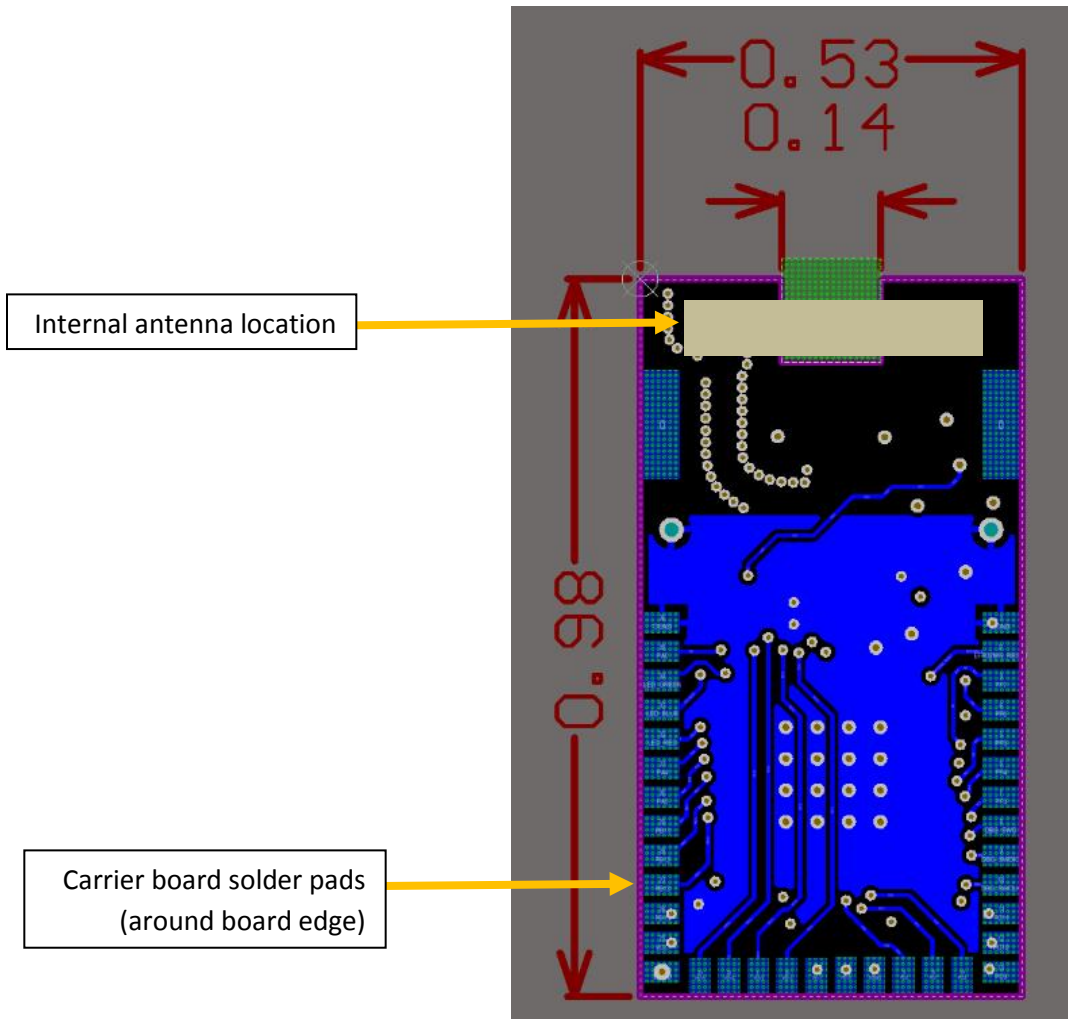

Dimensions in inches

Pin Interface

Radio Module pin number	Signal name	Description
1	DGND	Digital ground
2	EFR32MG RESET	Microcontroller reset
3	PF7	Microcontroller general purpose I/O
4	PF6	Microcontroller general purpose I/O
5	PF5	Microcontroller general purpose I/O
6	PF4	Microcontroller general purpose I/O
7	PF3	Microcontroller general purpose I/O
8	DBG_SWO	Serial Wire Debug trace data output
9	DBG_SWDIO	Serial Wire Debug data in/out
10	DBG_SWCLK	Serial Wire Debug clock
11	PC11	Microcontroller general purpose I/O
12	PC10	Microcontroller general purpose I/O
13	PC9	Microcontroller general purpose I/O
14	PC8	Microcontroller general purpose I/O
15	PC7	Microcontroller general purpose I/O
16	PC6	Microcontroller general purpose I/O
17	DGND	Digital ground
18	PD10	Microcontroller general purpose I/O
19	PD11	Microcontroller general purpose I/O
20	PD12	Microcontroller general purpose I/O
21	PD13	Microcontroller general purpose I/O
22	PD14	Microcontroller general purpose I/O
23	PD15	Microcontroller general purpose I/O
24	DGND	Digital ground
25	VCC	Module power input +5V dc
26	PB15	Microcontroller general purpose I/O
27	PB13	Microcontroller general purpose I/O
28	PB12	Microcontroller general purpose I/O
29	PB11	Microcontroller general purpose I/O
30	PA5	Microcontroller general purpose I/O
31	PA4	Microcontroller general purpose I/O
32	LED_RED	Status LED red
33	LED_BLUE	Status LED blue
34	LED_GREEN	Status LED green
35	PA0	Microcontroller general purpose I/O
36	DGND	Digital ground

3. Regulatory

- a. Radio modules must be labeled with the corresponding FCC/IC ID number. Product assemblies with radio modules in them must be labeled “Contains 200 Series Radio Module” followed by the FCC/IC ID.
- b. The following notice applies to the radio module and must also appear in its entirety in the final product user manual. In addition, based on the antennas and power parameters specified for this device, it must be operated at least 2.16 cm from the operator to ensure RF levels do not exceed what is considered healthy for human exposure.

**200 Series Radio Module**  
**FCC ID:XJQMSLINK0006**  
**IC ID:8505A-MSLINK0006**

This device complies with Part 15 of the United States FCC Rules, and Industry Canada's license-exempt RSSs. Operation is subject to the following two conditions: 1) This device may not cause interference, and 2) This device must accept any interference, including interference that may cause undesired operation of the device. Changes or modifications, including antenna changes not expressly approved by LORD Corporation could void the user's authority to operate the equipment.

Cet appareil est conforme à la Partie 15 des Règles de la FCC des États-Unis et aux RSSS exempts de licence d'Industrie Canada. Le fonctionnement est soumis aux deux conditions suivantes: 1) Cet appareil ne doit pas causer d'interférences et 2) Cet appareil doit accepter toute interférence, y compris les interférences pouvant entraîner un fonctionnement indésirable de l'appareil. Les changements ou modifications, y compris les changements d'antenne non expressément approuvés par LORD Corporation, pourraient annuler l'autorisation de l'utilisateur d'utiliser l'équipement.