

LORD QUICK START GUIDE

SG-Link®-200-OEM Wireless Analog Input Node

The SG-Link-200-OEM is a small, wireless, low-cost, two-channel analog input sensor node ready for OEM integration. Featuring one differential and one single-ended analog input channel and an internal temperature sensor. The SG-Link-200-OEM supports high resolution, low noise data collection at sample rates up to 1 kHz. Users can easily program nodes for continuous, periodic burst and event-triggered sampling with SensorConnect™.

To acquire sensor data, the SG-Link-200-OEM is used with a LORD Sensing WSDA gateway, and comes with the following configuration options.



	Configuration Option	Antenna Gain
SG-Link-200-OEM PCB	Integrated chip antenna	1.5 dBi
	U.F.L interface: Stub antenna, 2" cable	-0.9 dBi
	Terminal block (optional)	--
	Calibration Certificate	--

Table 1 - SG-Link-200-OEM Configuration Options Components

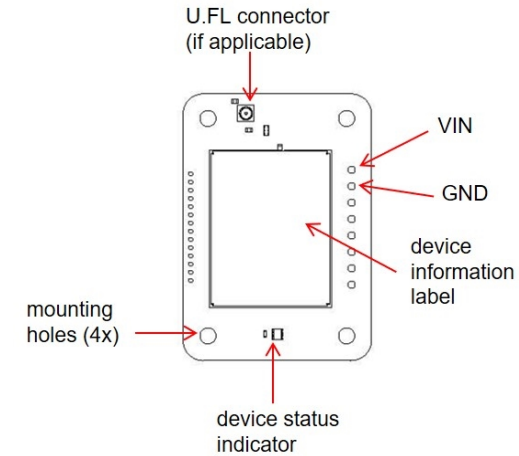

Figure 1 - Interface and Indicators

Indicator	Behavior	Node Status
Device status indicator	OFF	Node is OFF
	Rapid green flashing on start-up	Node is booting up
	1 (slow) green pulse per second	Node is idle and waiting for a command
	1 green blink every 2 seconds	Node is sampling
	Blue LED during sampling	Node is resynchronizing
	Red LED	Built-in test error

Table 2 - Indicator Behaviors

1. Pinout and Sensor Wiring

Symbol	Description	Pin Type	Range
SP+	Sensor Excitation Power to external sensors. Power will be duty cycled to sensors unless configured to power continuously.	Ouput	2.5 V, 100 mA
S+	Channel 1: Differential sensor input +	Analog Input	0 to 2.5 V
S-	Channel 1: Differential sensor input -	Analog Input	0 to 2.5 V
GND	Sensor Ground	GND	
SS	Channel 1: Three-wire input Used only for three wire configuration of quarter bridge strain gauges. Leave unconnected when not using quarter bridge configuration.	Input	0 to 2.5 V
AIN	Channel 2: Single-ended sensor input	Analog Input	0 to 2.5 V
GND	Power Ground	GND	
VIN	Input Power Supply	Power Input	3.3 to 30 V

Table 3 - SG-Link-200-OEM Pinout Descriptions

See below for wiring of other strain gauges.

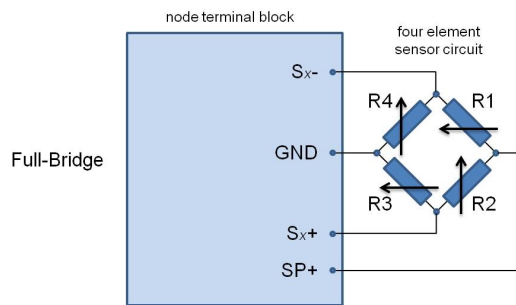

Figure 2 - Full-Bridge (Standard)

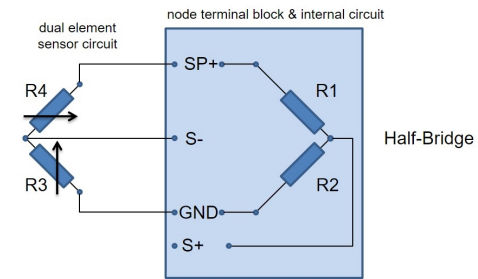

Figure 3 - Half-Bridge *

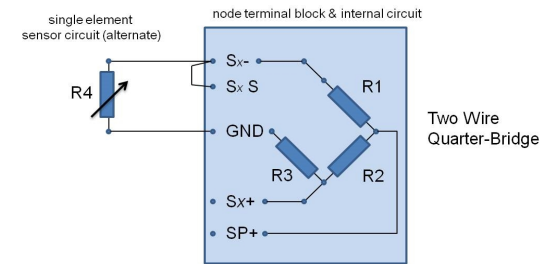

Figure 4 - Two Wire Quarter-Bridge *

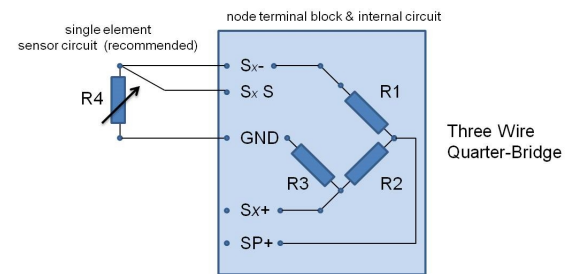

Figure 5 - Three Wire Quarter-Bridge *

* Requires optional on-board bridge completion

2. Node Operational Modes

Sensor nodes have three operational modes: *active*, *sleep*, and *idle*. When the node is sampling, it is in active mode. When sampling stops, the node is switched into idle mode, which is used for configuring node settings, and allows toggling between sampling and sleeping modes. The node will automatically go into the ultra low-power sleep mode after a user-determined period of inactivity. The node will not go into sleep mode while sampling.

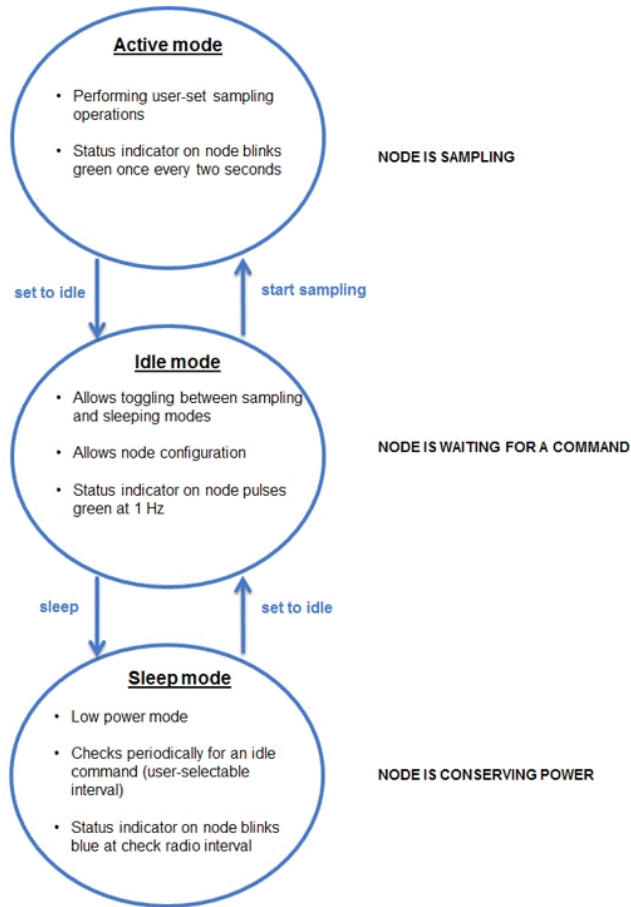

Figure 6 - Node Operational Modes

3. Install Software

Install the **SensorConnect** software on the host computer before connecting any hardware. Access the free software download on the LORD Sensing website at:



<http://www.microstrain.com/software>

4. Establish Gateway Communication

Drivers for the USB gateways are included the SensorConnect software installation. With the software installed, the USB gateway will be detected automatically whenever the gateway is plugged in.

1. Power is applied to the gateway through the USB connection. Verify the gateway status indicator is illuminated, showing the gateway is connected and powered on.
2. Open the SensorConnect™ software.
3. The gateway should appear in the Controller window automatically with a communication port assignment. If the gateway is not automatically discovered, verify the port is active on the host computer, and then remove and re-insert the USB connector.

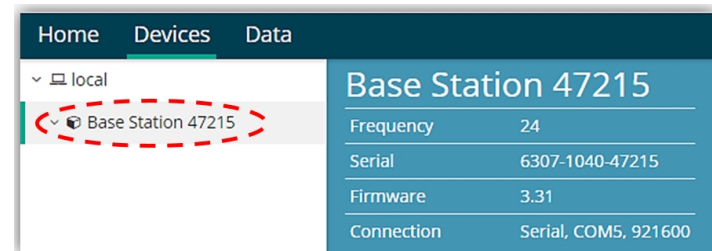

Figure 7 - USB Gateway Communication

5. Connect to Nodes

Several methods can be used in SensorConnect to establish communication with the nodes: the automatic node discovery on the same frequency, automatic node discovery on a different frequency, and add node manually.

A. Automatic Node Discovery on Same Frequency

If the base and node are on the same operating frequency, the node will populate below the Base Station listing when powering on the SG-Link-200-OEM.

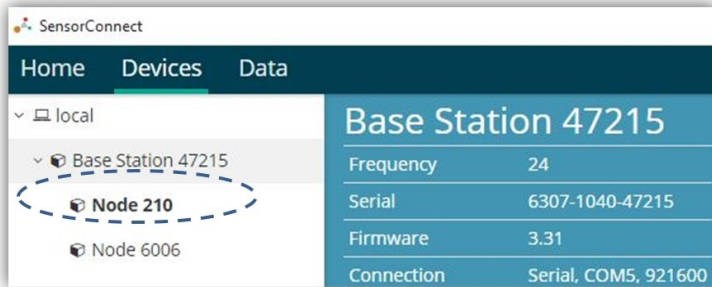

Figure 8 - Node Discovered On Same Frequency

B. Automatic Node Discovery on Different Frequency

If a red circle with a number appears next to the Base Station, the node is operating on a separate radio channel. Select the Base Station and then select the Nodes on Other Frequencies tile.

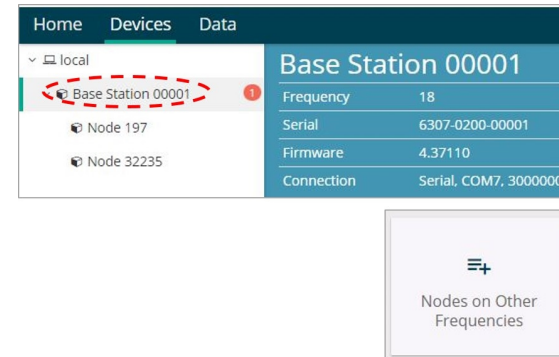

Figure 9 - Node On Other Frequency

Highlight the new node being added and select Move Node to Frequency (#).

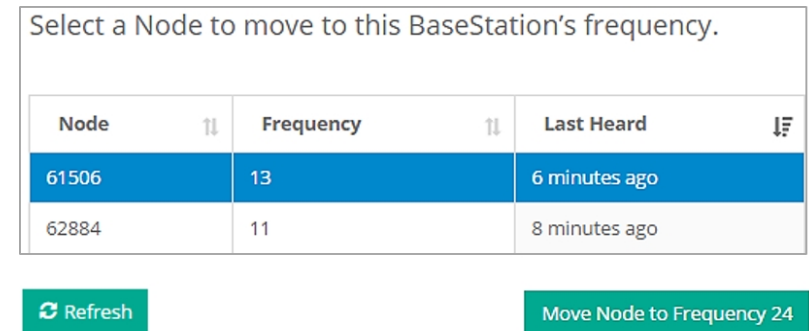

Figure 10 - Move Node

C. Manually Add Node

Adding a node manually requires entering the node address and its current frequency setting.

Figure 11 - Add Node By Address

If the node was successfully added, two confirmation messages will appear and it will be listed under the Base Station.

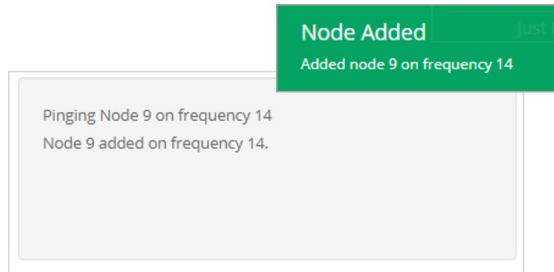

Figure 12 - Add Node Confirmation

If the node failed to be added, a failure message will appear. This means the node did not respond to the base station which could indicate the node is not in idle mode or it may be on another frequency. If "Add Node Anyway" is selected, it will associate that node with the channel entered but it is likely there will be a communication error. If the node was not in idle, move the base station to the frequency of the node and issue a "Set to Idle" command.

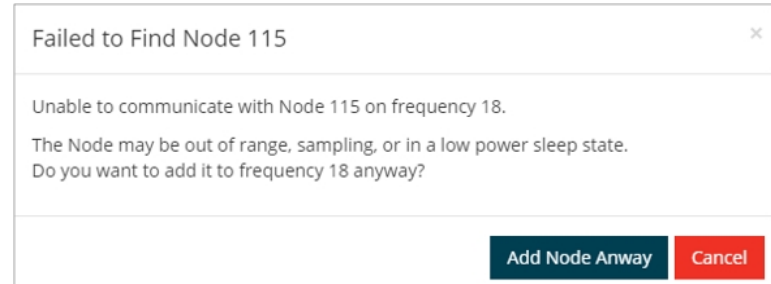
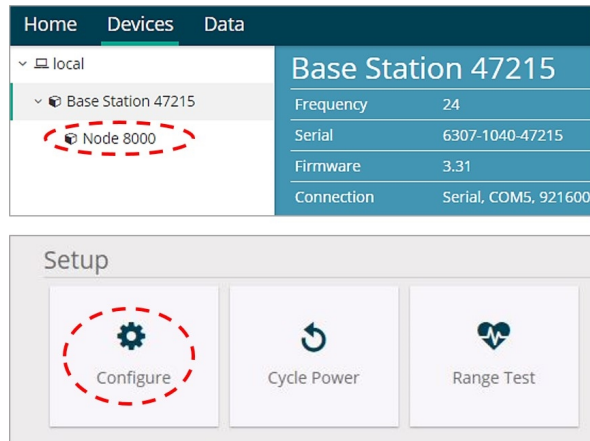

Figure 13 - Failure to Add Node

6. Configure Node

Node settings are stored to non-volatile memory and may be configured using SensorConnect. To access the node configuration menu, under Devices select the node and then the Configure tile.



The configuration menus show the channels and configuration options available for the type of node being used.

For this example the SG-Link-200-OEM tester board is on Differential channel 1.

1. From the Wireless Node Configuration menu, select Hardware > Input Range for Differential channel 1, select +/- 2.5 V from the drop down menu.



Figure 14 - Hardware Configuration Menu

2. Under Low Pass Filter, select 552 Hz from the Filter Cutoff drop down menu.

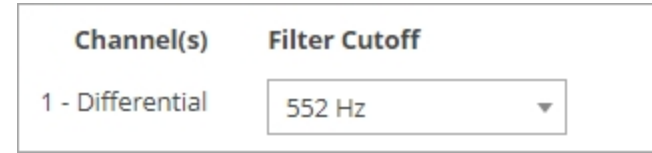

Figure 15 - Low Pass Filter

3. From the Wireless Node Configuration menu, select Calibration > Cal Tools > Shunt Cal to calibrate Microstrain.

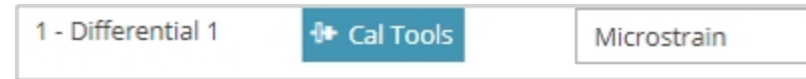

Figure 16 - Node Calibration Menu

7. Configure Sampling Setting and Start Data Acquisition

1. Left click on the Base Station > Sampling, and indicate the nodes to be sampled by checking the box to the left of each node.
2. Under Sampling, select Sample Rate from the drop down menu, select Continuously to sample indefinitely.

<input checked="" type="checkbox"/>	Node	Channels	Sampling
<input checked="" type="checkbox"/>	6386	1 Channel ▾	64 Hz continuously ▾

Figure 17 - Sampling Setting

3. Select Apply and Start Network.
4. Select Create Quick View Dashboard in the pop up window immediately to create a dashboard of the new data.

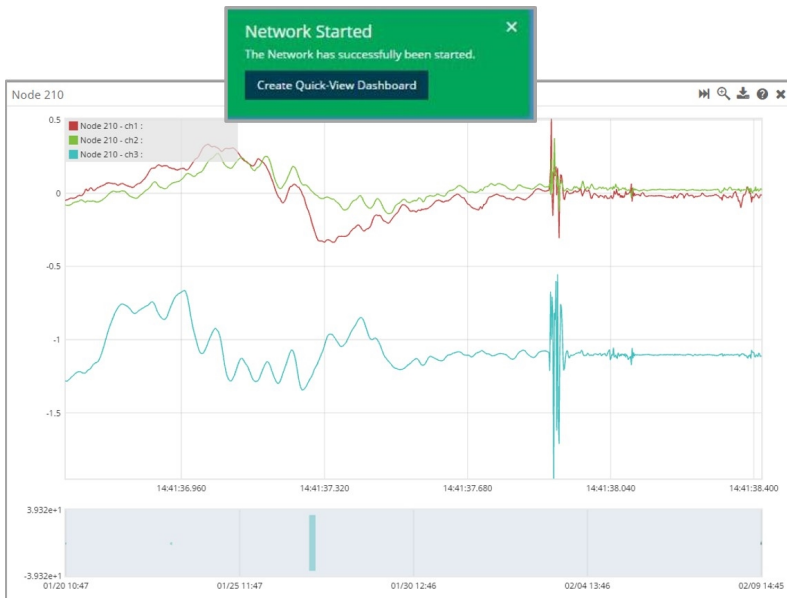

Figure 18 - Quick View Dashboard

Radio Specifications

The SG-Link-200-OEM employs a 2.4GHz IEEE 802.15.4-compliant radio transceiver for wireless communication. The radio is a direct-sequence spread spectrum radio and can be configured to operate on 16 separate frequencies ranging from 2.405 GHz to 2.480 GHz. Following the 802.15.4 standard, these frequencies are aliased as channels 11 through 26. For all newly manufactured nodes, the default setting is 2.425 GHz (channel 15).

SG-Link-200-OEM

FCC ID: XJQMSLINK0011

IC ID: 8505A-MSLINK00 11

This device complies with Part 15 of the United States FCC Rules, and Industry Canada's license-exempt RSSs. Operation is subject to the following two conditions: 1) This device may not cause interference, and 2) This device must accept any interference, including interference that may cause undesired operation of the device. Changes or modifications, including antenna changes not expressly approved by LORD Corporation could void the user's authority to operate the equipment.

Cet appareil est conforme à la Partie 15 des Règles de la FCC des États-Unis et aux RSSS exempts de licence d'Industrie Canada. Le fonctionnement est soumis aux deux conditions suivantes: 1) Cet appareil ne doit pas causer d'interférences et 2) Cet appareil doit accepter toute interférence, y compris les interférences pouvant entraîner un fonctionnement indésirable de l'appareil. Les changements ou modifications, y compris les changements d'antenne non expressément approuvés par LORD Corporation, pourraient annuler l'autorisation de l'utilisateur d'utiliser l'équipement.

ESD Sensitivity

The SG-Link-200-OEM is intended to be integrated in to an application appropriate housing to protect it from environmental elements, impact, and electrostatic discharge (ESD), which can disrupt operation or damage the PCB.



The SG-Link-200-OEM is susceptible to damage and/or disruption of normal operation from Electrostatic Discharge (ESD). ESD may cause the device to reset, which may require user intervention to continue data acquisition.