

XENON DATASHEET (V001)

DOWNLOAD PDF

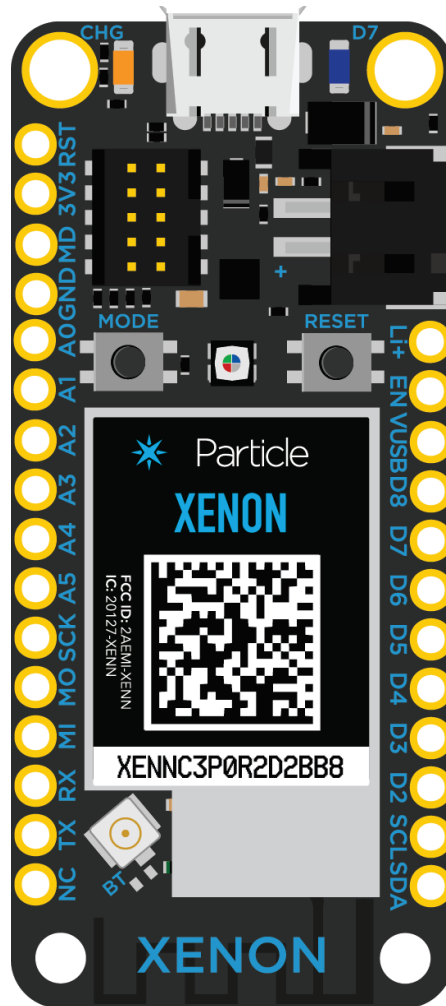

Functional description

Overview

The Xenon is a low cost mesh-enabled development board that can act as either an endpoint or repeater within a Particle Mesh network.

The Xenon is mesh only and designed to function as the endpoint of your IoT network. It is based on the Nordic nRF52840 and has built-in battery charging circuitry so it's easy to

connect a Li-Po and deploy your local network in minutes.

The Xenon is best for connecting sensors, motors, pumps, valves, and points of data-interest. Pair it with an Argon or Boron gateway to get all that great data into the Device Cloud.

Features

- Nordic Semiconductor nRF52840 SoC
 - ARM Cortex-M4F 32-bit processor @ 64MHz
 - 1MB flash, 256KB RAM
 - IEEE 802.15.4-2006: 250 Kbps
 - Bluetooth 5: 2 Mbps, 1 Mbps, 500 Kbps, 125 Kbps
 - Supports DSP instructions, HW accelerated Floating Point Unit (FPU) calculations
 - ARM TrustZone CryptoCell-310 Cryptographic and security module
 - Up to +8 dBm TX power (down to -20 dBm in 4 dB steps)
 - NFC-A tag
- On-board additional 4MB SPI flash
- 20 mixed signal GPIO (6 x Analog, 8 x PWM), UART, I2C, SPI
- Micro USB 2.0 full speed (12 Mbps)
- Integrated Li-Po charging and battery connector
- JTAG (SWD) Connector
- RGB status LED
- Reset and Mode buttons
- On-board PCB antenna
- u.FL connector for external antenna
- Meets the Adafruit Feather [specification](#) in dimensions and pinout
- FCC, CE and IC certified
- RoHS compliant (lead-free)

Interfaces

Block diagram

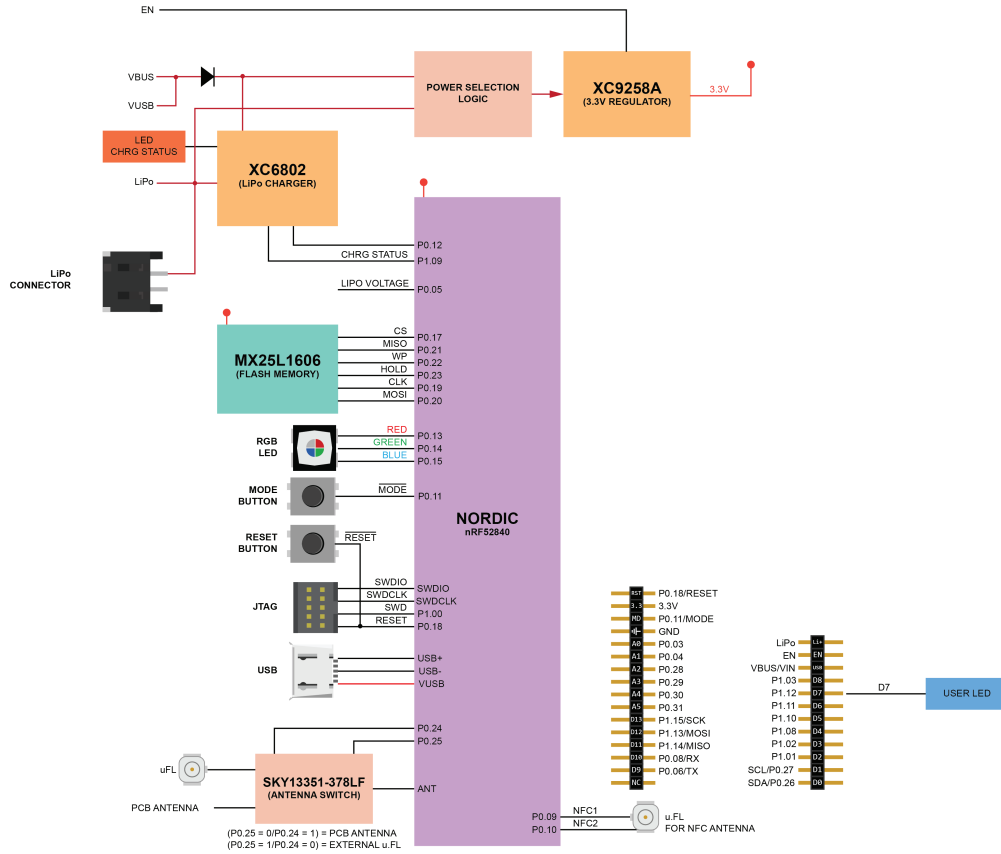

Power

USB PORT

The USB port is the easiest way to power up the Xenon. Please make sure that the USB port is able to provide at least 500mA. Power from the USB is regulated down to 3.3V by the on board Torex XC9258A step-down regulator.

VUSB PIN

The pin is internally connected to the VBUS of the USB port. The typical output should be around 4.5 to 5 VDC when the device is plugged into the USB port and 0 when not connected to a USB source. You can use this pin to power peripherals that operate at such voltages. Do not exceed the current rating of the USB port, which is nominally rated to 500mA. This pin is also protected with an internal fuse rated at 1000mA.

LiPo

If you want to make your projects truly wireless, you can power the device with a single cell LiPo/Lithium Ion (3.7V). The Xenon has an on board LiPo charger that will charge and power the device when USB source is plugged in, or power the device from the LiPo alone in the absence of the USB.

NOTE: Please pay attention to the polarity of the LiPo connector. Not all LiPo batteries follow the same polarity convention!

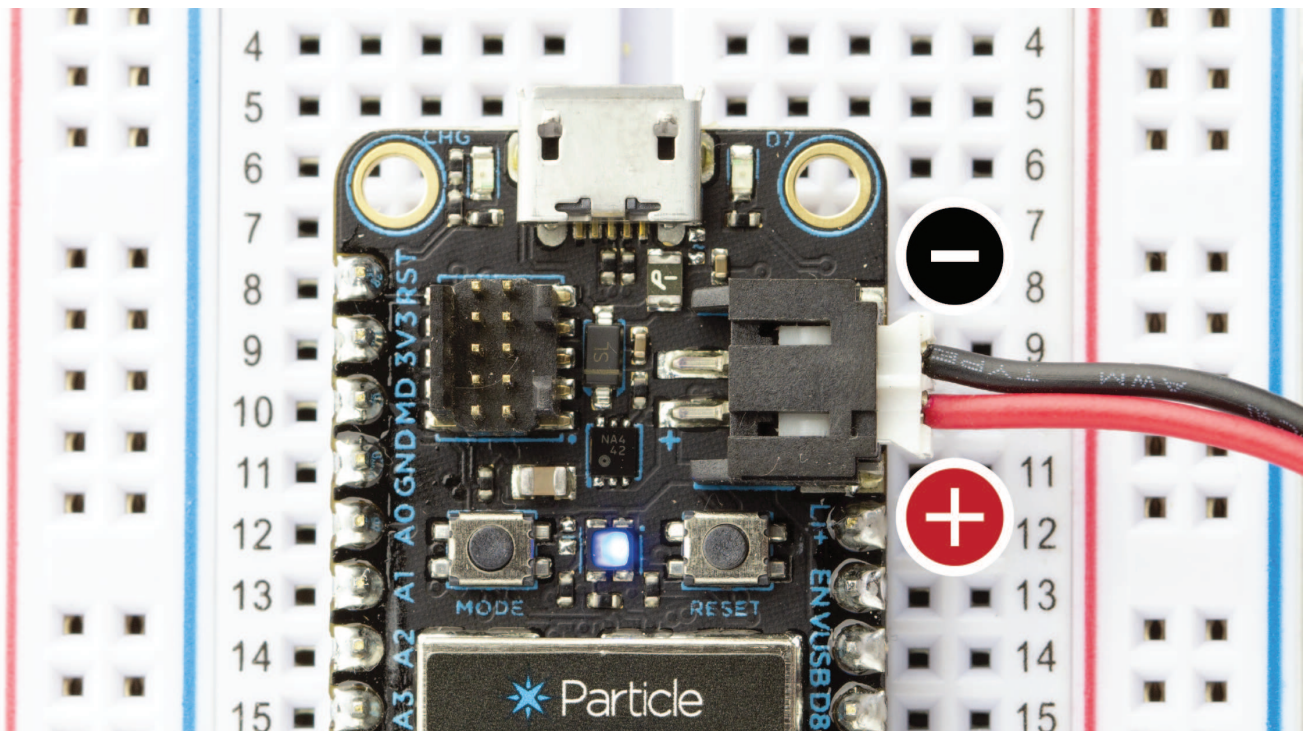

Li+ PIN

This pin is internally connected to the positive terminal of the LiPo connector. You can connect a single cell LiPo/Lithium Ion or a DC supply source to this pin for powering the Xenon. Remember that the input voltage range on this pin is 3.6 to 4.2 VDC.

3V3 PIN

This pin is the output of the on board 3.3V step-down switching regulator (Torex XC9258A). The regulator is rated at 1000mA max. When using this pin to power other devices or peripherals remember to budget in the current requirement of the Xenon first. This pin can also be used to power the Xenon in absence of the USB or LiPo power. When

powering over this pin, please connect the ENABLE pin to GND so that the on board regulator is disabled.

Antenna

There are two options for the Mesh antenna on the Xenon. It comes with an on-board PCB antenna which is selected by default in the device OS and a u.FL connector if you wish to connect an external antenna. If you wish to use the external antenna, you'll need to issue an appropriate command in the firmware.

FCC approved antenna

The following antenna is optional, as the Xenon comes with an on-board PCB antenna.

Particle Device	Frequency	Antenna Type	Manufacturer	MFG. Part #	Gain
Xenon	2400-2500 MHz	PCB Antenna	Particle	ANT-FLXV2	2.0dBi peak

Peripherals and GPIO

Peripheral Type	Qty	Input(I) / Output(O)
Digital	20	I/O
Analog (ADC)	6	I
UART	1	I/O
SPI	1	I/O
I2C	2	I/O
USB	1	I/O
PWM	8	O

Note: All GPIOs are only rated at 3.3VDC max.

SWD

The Xenon has a dedicated 10 pin debug connector that exposes the SWD interface of the nRF5280. This interface can be used to debug your code or reprogram your Xenon

bootloader, device OS, or the user firmware using any standard SWD tools including our Mesh Debugger.

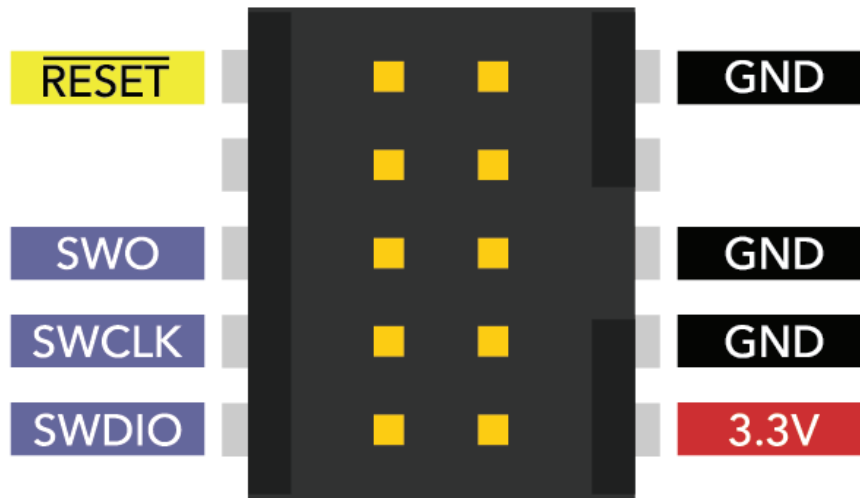

Memory map

nRF52840 Flash Layout Overview

- Bootloader (48KB, @0xF4000)
- User Application (128KB, @0xD4000)
- System (656KB, @0x30000)
- SoftDevice (192KB)

External SPI Flash Layout Overview (DFU offset: 0x80000000)

- OTA (1500KB, @0x00289000)
- Reserved (420KB, @0x00220000)
- FAC (128KB, @0x00200000)
- LittleFS (2M, @0x00000000)

Pins and button definitions

Pin markings

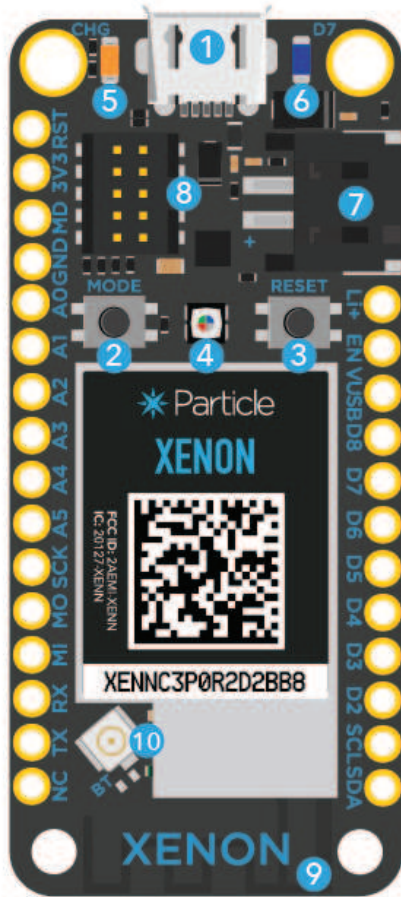

- 1 USB
- 2 MODE BUTTON
- 3 RESET BUTTON
- 4 RGB STATUS LED
- 5 CHARGE STATUS LED
- 6 USER LED (ON D7)
- 7 LiPo BATT CONNECTOR
- 8 DEBUG CONNECTOR (SWD)
- 9 ON-BOARD PCB ANTENNA FOR MESH
- 10 u.FL CONNECTOR FOR EXTERNAL MESH ANTENNA (OPTIONAL)

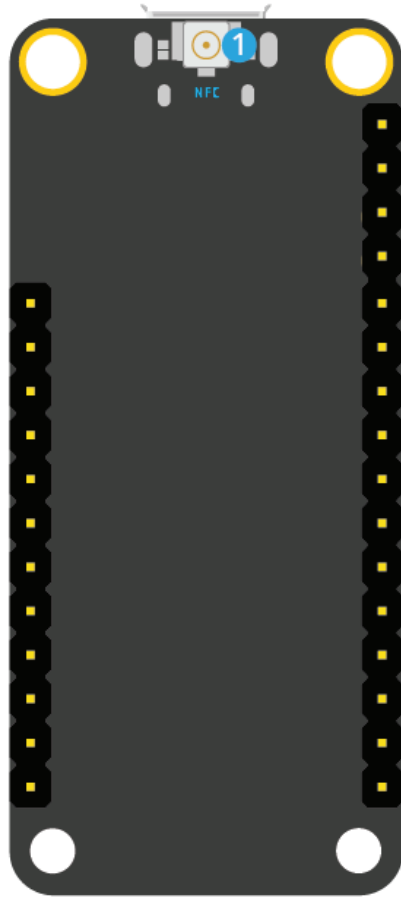

1 u.FL CONNECTOR FOR NFC ANTENNA

Pinout diagram

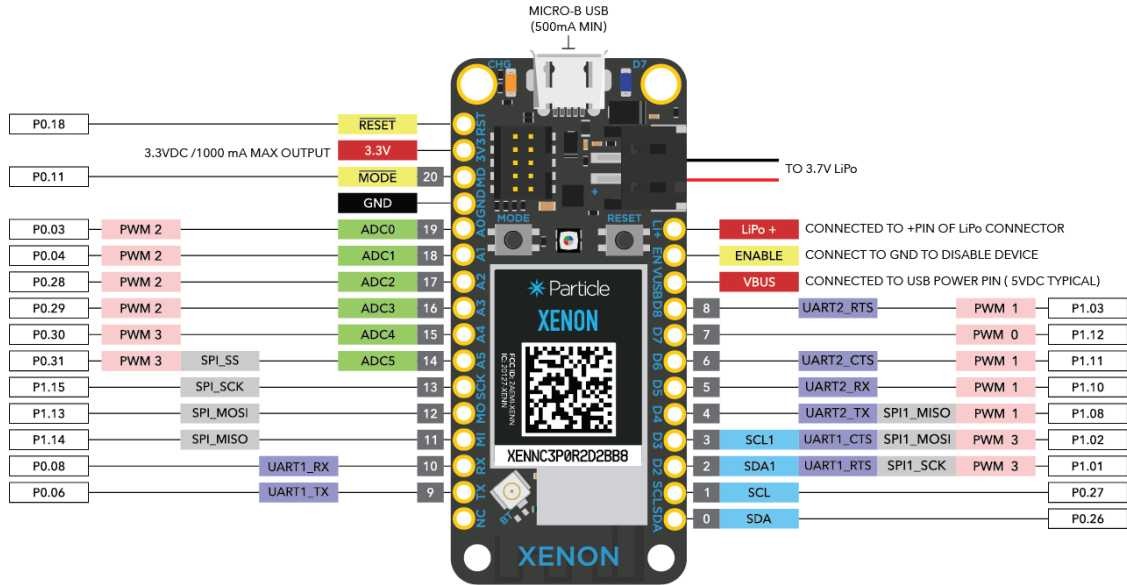

PWM 0 GROUP 0 PWM PINS	ADC ANALOG TO DIGITAL INPUT PINS	UART1 SERIAL COMMUNICATION PINS (SERIAL1)
PWM 1 GROUP 1 PWM PINS	PX.XX nRF52840 PIN NAMES	UART2 SERIAL COMMUNICATION PINS (SERIAL2)
PWM 2 GROUP 2 PWM PINS	SPI SPI COMMUNICATION PINS (SPI)	SPI1 SPI COMMUNICATION PINS (SPI1)
PWM 3 GROUP 3 PWM PINS	SDA/SCL I2C COMMUNICATION PINS (WIRE)	SDA1/SCL1 I2C COMMUNICATION PINS (WIRE1)

v1.0

You can download a high resolution [PDF version of the pin out here](#).

Pin description

Pin	Description
Li+	This pin is internally connected to the positive terminal of the LiPo battery connector.
VUSB	This pin is internally connected to the USB (+ve) supply.
3V3	This pin is the output of the on-board 3.3V regulator.
GND	System ground pin.
EN	Device enable pin is internally pulled-up. To disable the device, connect this pin to GND.
RST	Active-low system reset input. This pin is internally pulled-up.
MD	This pin is internally connected to the MODE button. The MODE function is active-low.
RX	Primarily used as UART RX, but can also be used as a digital GPIO.
TX	Primarily used as UART TX, but can also be used as a digital GPIO.
SDA	Primarily used as data pin for I2C, but can also be used as a digital GPIO.
SCL	Primarily used as clock pin for I2C, but can also be used as a digital GPIO.
MO,MI,SCK	These are the SPI interface pins, but can also be used as a digital GPIO.

Pin	Description
D2-D8	These are generic GPIO pins. D2-D8 are PWM-able.
A0-A5	These are analog input pins that can also act as standard digital GPIO. A0-A5 are PWM-able.

LED status

System RGB LED

For a detailed explanation of different color codes of the RGB system LED, please take a look [here](#).

Charge status LED

State	Description
ON	Charging in progress
OFF	Charging complete

Technical specifications

Absolute maximum ratings ^[1]

Parameter	Symbol	Min	Typ	Max	Unit
Supply Input Voltage	V_{IN-MAX}			+6.2	V
Battery Input Voltage	V_{LiPo}			+6.5	V
Supply Output Current	$I_{3V3-MAX-L}$			1000	mA
Storage Temperature	T_{stg}	-30		+75	°C
ESD Susceptibility HBM (Human Body Mode)	V_{ESD}			2	kV

^[1] Stresses beyond those listed under absolute maximum ratings may cause permanent damage to the device. These are stress ratings only, and functional operation of the device at these or any other conditions beyond those indicated under recommended operating

conditions is not implied. Exposure to absolute-maximum-rated conditions for extended periods may affect device reliability.

Recommended operating conditions

Parameter	Symbol	Min	Typ	Max	Unit
LiPo Battery Voltage	V_{LiPo}	+3.3		+4.4	V
Supply Input Voltage	V_{3V3}	+3.0	+3.3	+3.6	V
Supply Output Voltage	V_{3V3}		+3.3		V
Operating Current (uC on, Radio ON)	$I_{Li+ avg}$		6	20	mA
Operating Current (uC on, Radio OFF)	$I_{Li+ avg}$		TBD	TBD	mA
Operating Current (EN pin = LOW)	$I_{disable}$		20	30	uA
Sleep Current (4.2V LiPo, Radio OFF)	I_{Qs}		TBD	TBD	mA
Deep Sleep Current (4.2V LiPo, Radio OFF)	I_{Qds}		TBD	TBD	uA
Operating Temperature	T_{op}	-20		+60	°C
Humidity Range Non condensing, relative humidity				95	%

Radio specifications

Xenon uses the Nordic Semiconductor nRF52840 SoC as the main controller and the mesh radio.

Feature	Description
Operating Frequencies	2360 to 2500 MHz
Output Power	Programmable -20dBm to +8dBm
PLL channel spacing	1 MHz
On the air data rate	125 to 2000 kbps

I/O Characteristics

These specifications are based on the nRF52840 datasheet.

Parameter	Symbol	Conditions	Min	Typ	Max	Unit
Input high voltage	V_{IH}		0.7*3.3	--	3.3	V
Input low voltage	V_{IL}		0		0.3*3.3	V
Current at GND+0.4 V, output set low, high drive	$I_{OL,HDL}$	$V_{3V3} \geq 2.7V$	6	10	15	mA
Current at V_{3V3} -0.4 V, output set high, high drive	$I_{OH,HDH}$	$V_{3V3} \geq 2.7V$	6	9	14	mA
Pull-up resistance	R_{PU}		11	13	16	k Ω
Pull-down resistance	R_{PD}		11	13	16	k Ω

Mechanical specifications

Dimensions and Weight

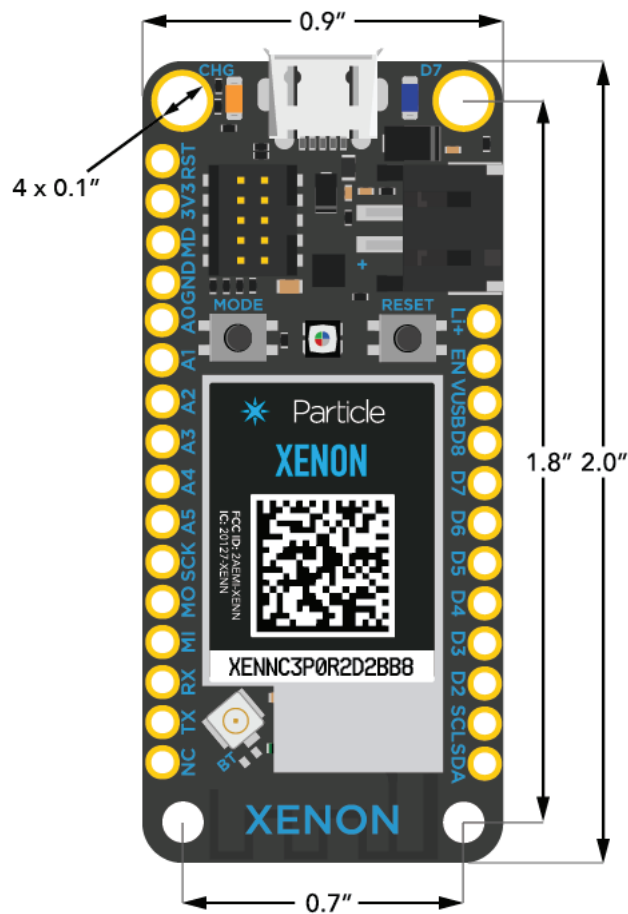

- Weight = 10 grams

Mating connectors

The Xenon uses two single row 0.1" pitch male header pins. One of them is 16 pin while the other is 12 pin. It can be mounted with matching 0.1" pitch female headers with a typical height of 0.335" (8.5mm). When you search for parts like these it can be difficult to navigate the thousands of parts available online so here are a few good choices for the Xenon:

Description	MFG	MFG Part Number
16-pin 0.1" (2.54mm) Female Header	Sullins	PPTC161LFBN-RC
16-pin 0.1" (2.54mm) Female Header	TE	6-535541-4
12-pin 0.1" (2.54mm) Female Header	Sullins	PPTC121LFBN-RC
12-pin 0.1" (2.54mm) Female Header	TE	6-534237-0

Recommended PCB land pattern

The Xenon can be directly soldered onto the PCB or be mounted with the above mentioned female headers.

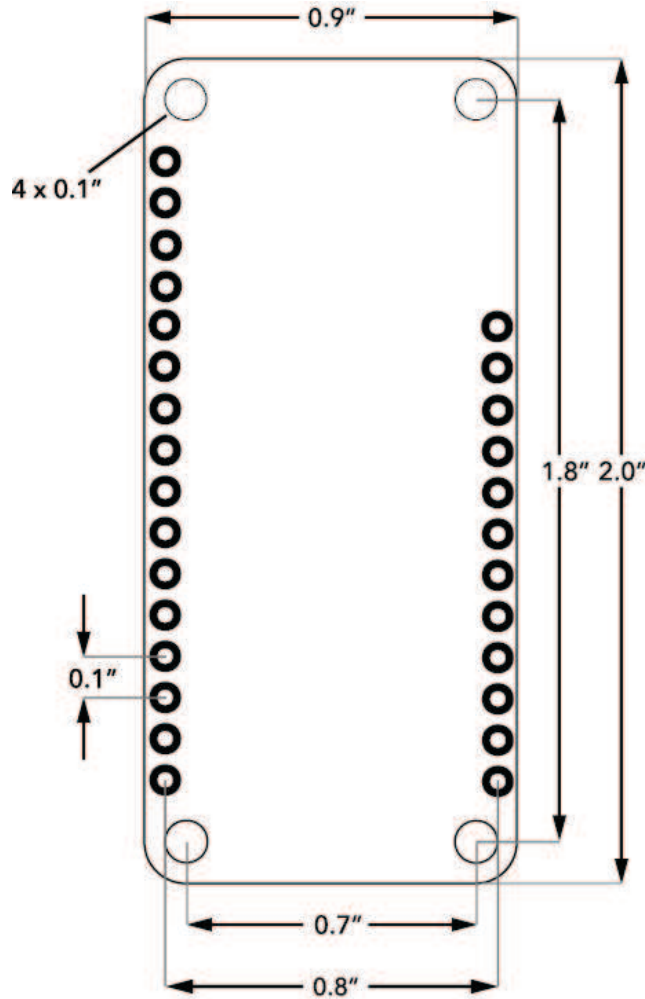

Schematic

The complete schematic and board files are open source and available on Particle's GitHub repository [here](#).

Power

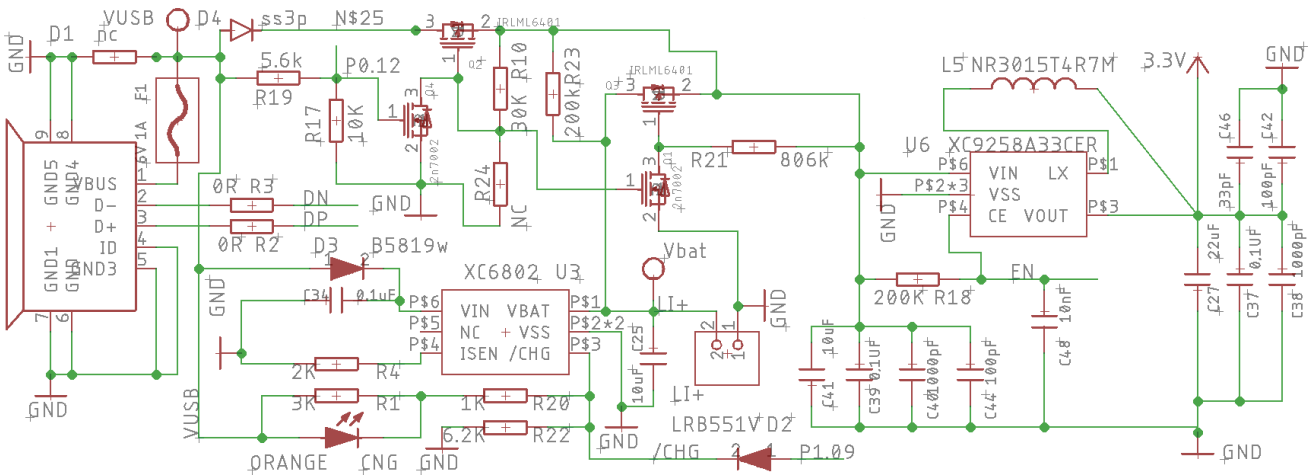

nRF52840

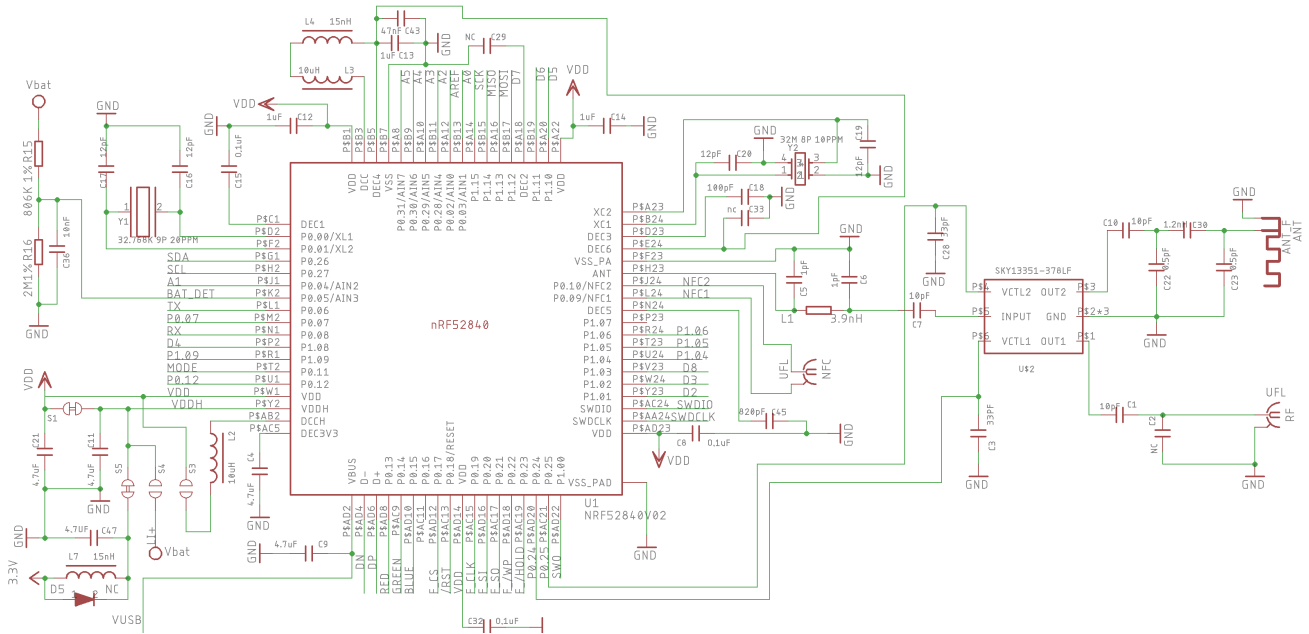

SPI FLASH

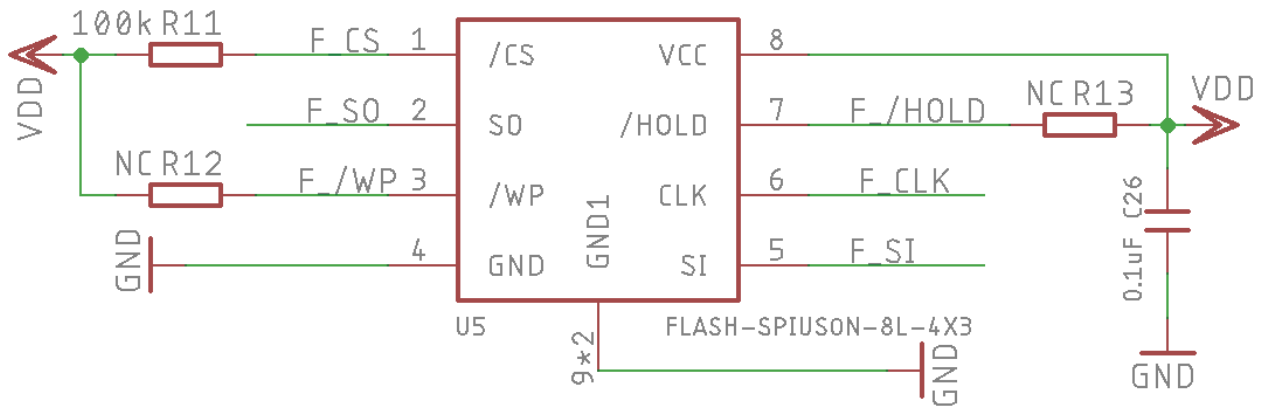

Interfaces

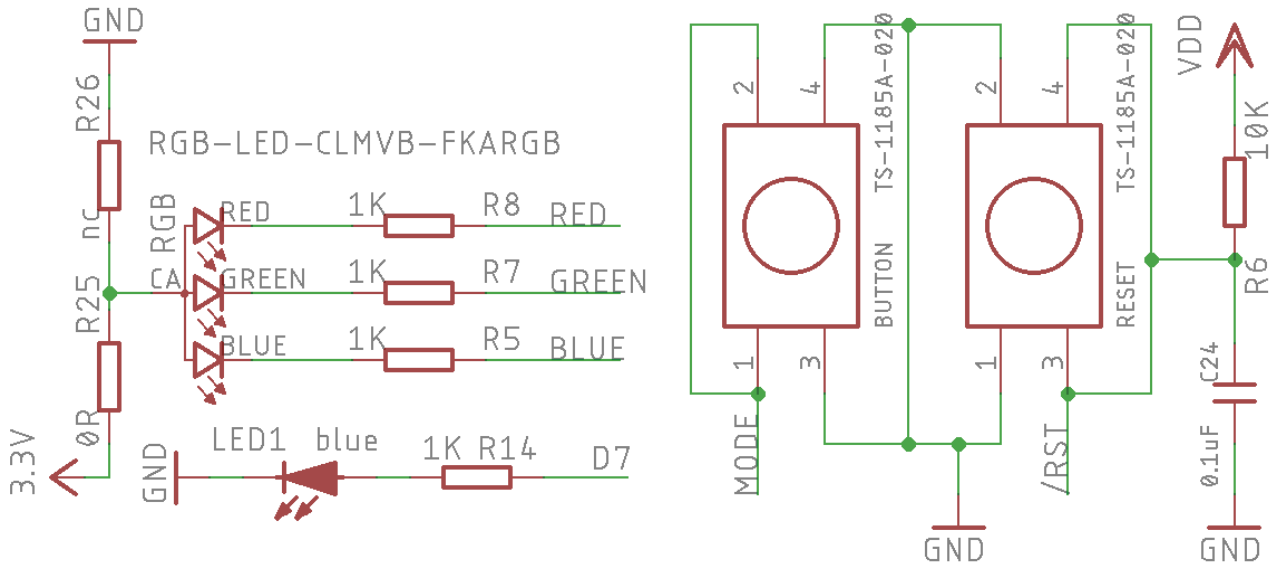

Ordering information

Xenons are available from store.particle.io in single quantities.

Qualification and approvals



- Model Number: XENN
- RoHS
- CE
- FCC ID: 2AEMI-XENN
- IC: 20127-XENN

Product Handling

ESD Precautions

The Xenon contains highly sensitive electronic circuitry and is an Electrostatic Sensitive Device (ESD). Handling Xenon without proper ESD protection may destroy or damage it permanently. Proper ESD handling and packaging procedures must be applied throughout the processing, handling and operation of any application that incorporates Xenon. ESD precautions should be implemented on the application board where the Xenon is mounted. Failure to observe these precautions can result in severe damage to the Xenon!

Connectors

There are four connectors on the Xenon that will get damaged with improper usage. The JST connector on the circuit board, where you plug in the LiPo battery, is very durable but the connector on the battery itself is not. When unplugging the battery, take extra precaution to **NOT** pull the connector using the wires, but instead hold the plug at its base to avoid putting stress on the wires. This can be tricky with bare hands - nose pliers are your friend here.

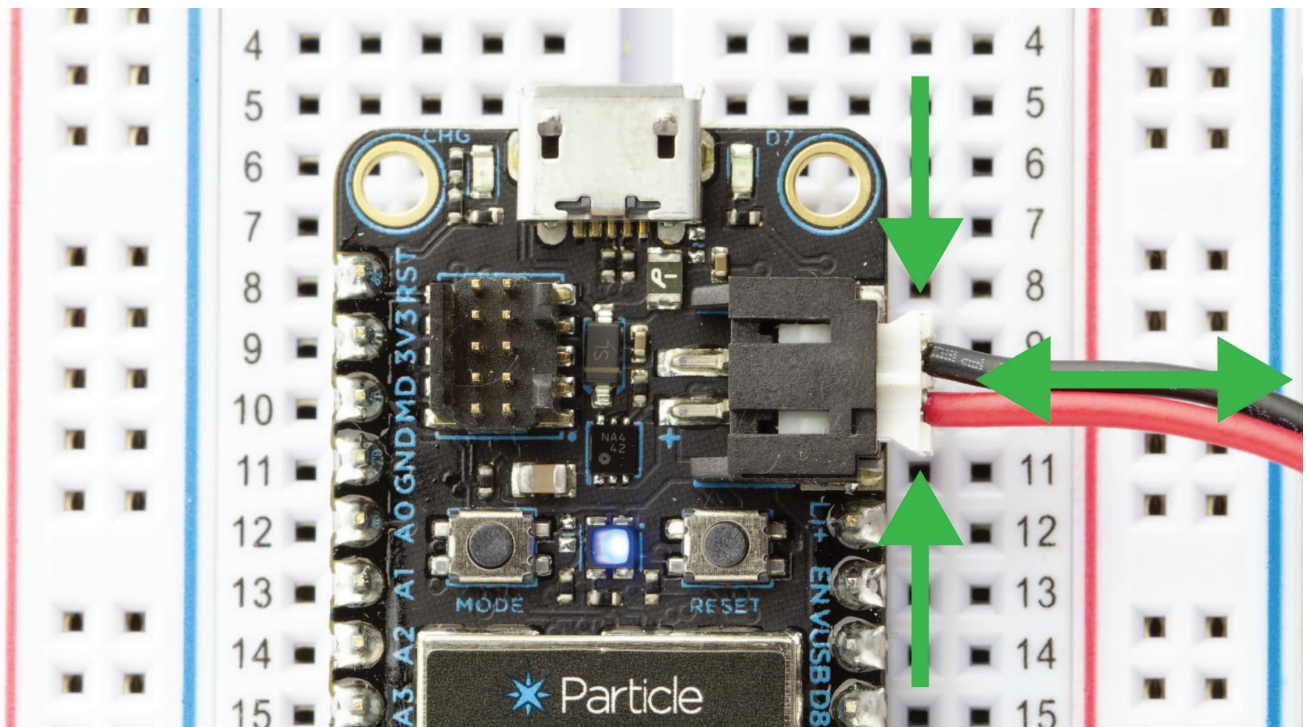

The micro B USB connector on the Xenon is soldered on the PCB with large surface pads as well as couple of through hole anchor points. Despite this reinforcement, it is very easy to rip out the connector if too much stress is put on in the vertical direction.

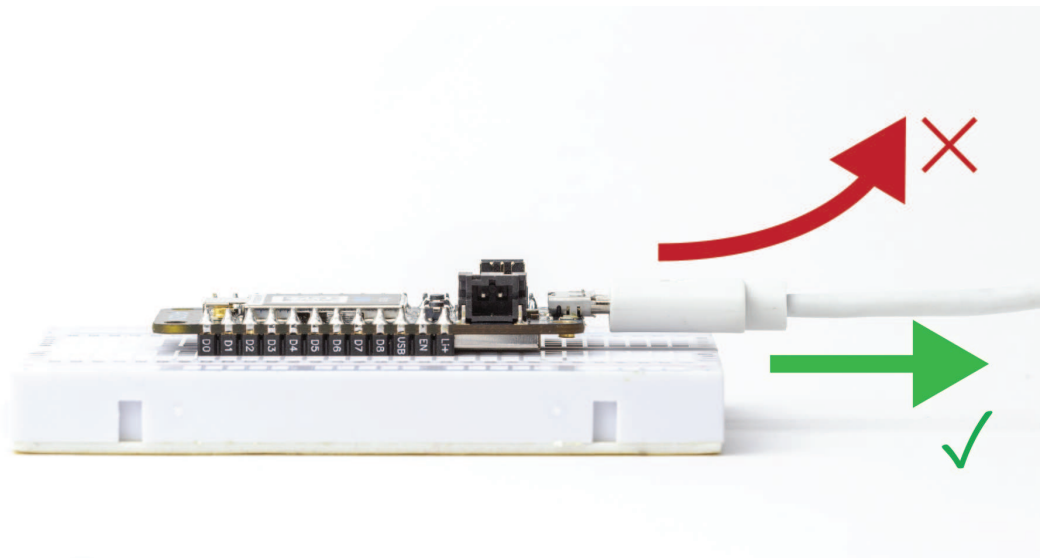

The u.FL antenna connector is a very fragile piece of hardware (and is fancy too with all the gold plating). The connector was not designed to be constantly plugged and unplugged. Care must be taken not to put stress on it at any time (yes, swinging the Xenon by the antenna is a very bad idea, this is not your cat). The antenna pin is also the most static sensitive and you can destroy the radio with improper handling. If you are feeling adventurous, we highly recommend putting a tiny dab of glue (epoxy, rubber cement, liquid tape or hot glue) on the connector to securely hold the plug in place.

The 10 pin SWD connector provides an easy in-system debugging access to the device. The pins on the connector can easily be damaged if the mating connector cable is inserted improperly. If you are trying to debug the device, you probably are not in a good mood to begin with. The last thing you want is to render the connector useless. Be nice, and be gentle on the connector. Good luck with the debugging!

Breadboarding

The breadboard provided with the Xenon is specifically designed to require low insertion force. This makes it easy to plug the Xenon in and out of the breadboard. If you end up using a different breadboard, remember that it may require more force. In this case, always remember to pinch-hold your precious Xenon by the sides (along the header pins) when plugging-unplugging and not by the USB connector (don't be this person).

Default settings

The Xenon comes preprogrammed with a bootloader and a user application called Tinker. This application works with an iOS and Android app also named Tinker that allows you to

very easily toggle digital pins, take analog and digital readings and drive variable PWM outputs.

The bootloader allows you to easily update the user application via several different methods, USB, OTA, Serial Y-Modem, and also internally via the Factory Reset procedure. All of these methods have multiple tools associated with them as well.

FCC IC CE Warnings and End Product Labeling Requirements

Federal Communication Commission Interference Statement This equipment has been tested and found to comply with the limits for a Class B digital device, pursuant to Part 15 of the FCC Rules. These limits are designed to provide reasonable protection against harmful interference in a residential installation. This equipment generates, uses and can radiate radio frequency energy and, if not installed and used in accordance with the instructions, may cause harmful interference to radio communications. However, there is no guarantee that interference will not occur in a particular installation. If this equipment does cause harmful interference to radio or television reception, which can be determined by turning the equipment off and on, the user is encouraged to try to correct the interference by one of the following measures:

- Reorient or relocate the receiving antenna.
- Increase the separation between the equipment and receiver.
- Connect the equipment into an outlet on a circuit different from that to which the receiver is connected.
- Consult the dealer or an experienced radio/TV technician for help.

FCC Caution: Any changes or modifications not expressly approved by the party responsible for compliance could void the user's authority to operate this equipment. This device complies with Part 15 of the FCC Rules. Operation is subject to the following two conditions:

1. This device may not cause harmful interference, and
2. This device must accept any interference received, including interference that may cause undesired operation.

FCC Radiation Exposure Statement: This equipment complies with FCC radiation exposure limits set forth for an uncontrolled environment. This transmitter module must not be co-located or operating in conjunction with any other antenna or transmitter. This

End equipment should be installed and operated with a minimum distance of 20 centimeters between the radiator and your body.

IMPORTANT NOTE: In the event that these conditions can not be met (for example certain laptop configurations or co-location with another transmitter), then the FCC authorization is no longer considered valid and the FCC ID can not be used on the final product. In these circumstances, the OEM integrator will be responsible for re-evaluating the end product (including the transmitter) and obtaining a separate FCC authorization.

End Product Labeling The final end product must be labeled in a visible area with the following:

- Contains FCC ID: 2AEMI-XENN

Manual Information to the End User The OEM integrator has to be aware not to provide information to the end user regarding how to install or remove this RF module in the user's manual of the end product which integrates this module.

Canada Statement This device complies with Industry Canada's licence-exempt RSSs. Operation is subject to the following two conditions:

1. This device may not cause interference; and
2. This device must accept any interference, including interference that may cause undesired operation of the device.

Le présent appareil est conforme aux CNR d'Industrie Canada applicables aux appareils radio exempts de licence.

L'exploitation est autorisée aux deux conditions suivantes:

1. l'appareil ne doit pas produire de brouillage;
2. l'utilisateur de l'appareil doit accepter tout brouillage radioélectrique subi, même si le brouillage est susceptible d'en compromettre le fonctionnement.

Caution Exposure: This device meets the exemption from the routine evaluation limits in section 2.5 of RSS102 and users can obtain Canadian information on RF exposure and compliance. Le dispositif répond à l'exemption des limites d'évaluation de routine dans la section 2.5 de RSS102 et les utilisateurs peuvent obtenir des renseignements canadiens sur l'exposition aux RF et le respect.

The final end product must be labelled in a visible area with the following: The Industry Canada certification label of a module shall be clearly visible at all times when installed in the host device, otherwise the host device must be labelled to display the Industry

Canada certification number of the module, preceded by the words “Contains transmitter module”, or the word “Contains”, or similar wording expressing the same meaning, as follows:

- Contains transmitter module IC: 20127-XENN

This End equipment should be installed and operated with a minimum distance of 20 centimeters between the radiator and your body. Cet équipement devrait être installé et actionné avec une distance minimum de 20 centimètres entre le radiateur et votre corps.

The end user manual shall include all required regulatory information/warning as shown in this manual.

Revision history

Revision	Date	Author	Comments
v001	26 Oct 2018	MB	Initial release

Known Errata

Contact

Web

<https://www.particle.io>

Community Forums

<https://community.particle.io>

Email

<https://support.particle.io>

