



Outdoor 802.11n Wireless Access Point (P/N DA2131-V1A)

Owner's Manual

1308197 Rev. C

Federal Communications Commission Statement

This device complies with Part 15 of the FCC Rules and RSS-210 Issue 8 of Canada. Operation is subject to the following two conditions:

- This device may not cause harmful interference, and
- This device must accept any interference received, including interference that may cause undesired operation.

This equipment has been tested and found to comply with the limits for a class B digital device, pursuant to Part 15 of the Federal Communications Commission (FCC) rules. These limits are designed to provide reasonable protection against harmful interference in a residential installation. This equipment generates, uses, and can radiate radio frequency energy and, if not installed and used in accordance with the instructions, may cause harmful interference to radio communications. However, there is no guarantee that interference will not occur in a particular installation. If this equipment does cause harmful interference to radio or television reception, which can be determined by turning the equipment off and on, the user is encouraged to try to correct the interference by one or more of the following measures:

- Reorient or relocate the receiving antenna.
- Increase the separation between the equipment and receiver.
- Connect the equipment into an outlet on a circuit different from that to which the receiver is connected.
- Consult the dealer or an experienced radio/TV technician for help.

Reprinted from the Code of Federal Regulations #47, part 15.193, 1993. Washington DC: Office of the Federal Register, National Archives and Records Administration, U.S. Government Printing Office.

Canadian Department of Communications

This device complies with Industry Canada licence-exempt RSS-210 standard. Operation is subject to the following two conditions: (1) this device may not cause interference, and (2) this device must accept any interference, including interference that may cause undesired operation of the device.

Le manuel d'utilisation des appareils radio exempts de licence doit contenir l'énoncé qui suit, ou l'équivalent, à un endroit bien en vue et/ou sur les appareils :

Le présent appareil est conforme aux CNR d'Industrie Canada applicables aux appareils radio exempts de licence. L'exploitation est autorisée aux deux conditions suivantes : (1) l'appareil ne doit pas produire de brouillage, et (2) l'utilisateur de l'appareil doit accepter tout brouillage radioélectrique subi, même si le brouillage est susceptible d'en compromettre le fonctionnement.

FCC Caution: To assure continued compliance, any changes or modifications not expressly approved by the party responsible for compliance could void the user's authority to operate this equipment. (Example - use only shielded interface cables when connecting to computer or peripheral devices).

FCC Radio Frequency Exposure Caution Statement

In order to maintain compliance with the FCC RF exposure guidelines, this equipment should be installed and operated with minimum distance 20cm between the radiator and your body. Use only with supplied antenna. Unauthorized antenna, modification, or attachments could damage the transmitter and may violate FCC regulations. Any changes of modifications not expressly approved by the grantee of this device could void the users authority to operate the equipment.

Installation and use of this Wireless LAN device must be in strict accordance with the instructions included in the user documentation provided with the product. Any changes or modifications (including the antennas) made to this device that are not expressly approved by the manufacturer may void the user's authority to operate the equipment. The manufacturer is not responsible for any radio or television interference caused by unauthorized modification of this device, or the substitution or attachment of connecting cables and equipment other than manufacturer specified. It is the responsibility of the user to correct any interference caused by such unauthorized modification, substitution or attachment. Manufacturer and its authorized resellers or distributors will assume no liability for any damage or violation of government regulations arising from failing to comply with these guidelines.

This device and its antenna(s) must not be co-located or operating in conjunction with any other antenna or transmitter.

Declaration of Conformity (R&TTE directive 1999/5/EC)

The following items were completed and are considered relevant and sufficient:

- Essential requirements as in [Article 3]
- Protection requirements for health and safety as in [Article 3.1a]
- Testing for electric safety according to [EN 60950]
- Protection requirements for electromagnetic compatibility in [Article 3.1b]
- Testing for electromagnetic compatibility in [EN 301 489-1] & [EN 301]
- Testing according to [489-17]
- Effective use of the radio spectrum as in [Article 3.2]
- Testing for radio test suites according to [EN 300 328-2]

WARNING: TO PREVENT FIRE OR SHOCK HAZARD, DO NOT EXPOSE THIS PRODUCT TO RAIN OR MOISTURE. THE UNIT MUST NOT BE EXPOSED TO DRIPPING OR SPLASHING WATER.

CAUTION: DO NOT OPEN THE UNIT. DO NOT PERFORM ANY SERVICING OTHER THAN THAT CONTAINED IN THE INSTALLATION AND TROUBLESHOOTING INSTRUCTIONS. REFER ALL SERVICING TO QUALIFIED SERVICE PERSONNEL.

CAUTION: THIS DEVICE MUST BE INSTALLED AND USED IN STRICT ACCORDANCE WITH THE MANUFACTURER'S INSTRUCTIONS AS DESCRIBED IN THE USER DOCUMENTATION THAT COMES WITH THE PRODUCT.

WARNING: POSTPONE INSTALLATION UNTIL THERE IS NO RISK OF THUNDERSTORM OR LIGHTNING ACTIVITY IN THE AREA.

When using this device, basic safety precautions should always be followed to reduce the risk of fire, electric shock and injury to persons, including the following:

- Read all of the instructions {listed here and/or in the user manual} before you operate this equipment.
- Give particular attention to all safety precautions.
- Retain the instructions for future reference.
- Comply with all warning and caution statements in the instructions.
- Observe all warning and caution symbols that are affixed to this equipment.
- Comply with all instructions that accompany this equipment.
- Avoid using this product during an electrical storm. There may be a risk of electric shock from lightning. For added protection for this product during a lightning storm, or when it is left unattended and unused for long periods of time, unplug the power supply, and disconnect the Cat 5e to the N-WAP at the POE Injector. This will prevent damage to the product due to lightning and power surges. It is recommended that the customer install an AC surge protector in the AC outlet to which this device is connected. This is to avoid damaging the equipment by local lightning strikes and other electrical surges. Operate this product only from the type of power source indicated on the product's marking label.
- If you are not sure of the type of power supplied to your home, consult your dealer or local power company.
- Upon completion of any service or repairs to this product, ask the service technician to perform safety checks to determine that the product is in safe operating condition.

Installation of this product must be in accordance with national wiring codes and conform to local regulations.

Place POE Injector to allow for easy access when disconnecting the power cord/adapter of the device from the AC wall outlet.

Wipe the unit with a clean, dry cloth. Never use cleaning fluid or similar chemicals. Do not spray cleaners directly on the unit or use forced air to remove dust.

TABLE OF CONTENTS

Chapter 1 Introduction	1
Overview	1
Product Features	1
Package Content	1
Physical Details	2
Chapter 2 Physical Installation	5
Physical Installation Steps	5
Chapter 3 Network Settings	10
Configuring and monitoring your DA2131-V1A from web browser	10
Chapter 4 Basic System Settings	16
Setup Wizard	16
DHCP	16
Static	17
PPPOE	18
L2TP	19
PPTP	20
Configure Wireless Settings	22
Operation Mode	23
Internet Settings	24
LAN Settings	26
VPN Passthrough	28
Advanced Wireless Settings	31
Security	33
WDS	42
Status	49
Firewall	52
Port Forwarding	53
Administration	57
Firmware Update	58
Settings Management	59
System Log	61
Appendix A DA2131-V1A Specifications	62



Chapter 1

Introduction

Overview

The DA2131-V1A Outdoor Wireless Access Point from Legrand now extends your home network's wireless reach to locations outside the home, such as patios or pool areas. With its environmental protection, the DA2131-V1A can perform under rigorous weather conditions including heavy rain and wind. With its Power over Ethernet (PoE) design, it can be easily installed in the areas where power outlets are not available.

With built-in IEEE 802.11b/g/n wireless network capability, the Outdoor N-WAP allows any computer and wireless enabled network client connect to it without additional cabling. With an 802.11n compatible wireless adapter installed in your PC, the files can be transferred at speeds up to 150Mbps. The radio coverage is also designed specifically for outdoor use.

To secure the wireless communication, the Outdoor N-WAP supports the most up-to-date encryption: 64/128-bit WEP, WPA / WPA2, WPA-PSK / WPA2-PSK and 802.1x authority to secure and protect your wireless LAN. MAC filtering and SSID broadcast control are provided to consolidate the wireless network security and prevent unauthorized wireless connection.

The DA2131-V1 supports multiple modes, including AP/Client, WDS Bridge and WDS Repeater.

Product Features

- IEEE 802.11b/g/n wireless standard compliant
- 10/100Mbps RJ-45 ports with auto MDI/MDI-X supported
- Supports 64/128-bit WEP, WPA, WPA-PSK, WPA2, WPA2-PSK and 802.1x encryption

Package Content

The contents of your product package should include the following items:

- DA2131-V1A 802.11n Outdoor Wireless Access Point
- POE Injector
- Power Adaptor (12V, 1A)
- Mounting Tie x 2
- Installation/Instruction Sheet
- A CD containing this manual.

Physical Details

The following figures illustrate the physical details of the Outdoor N-WAP.

1.1 The Rear Panel – LED

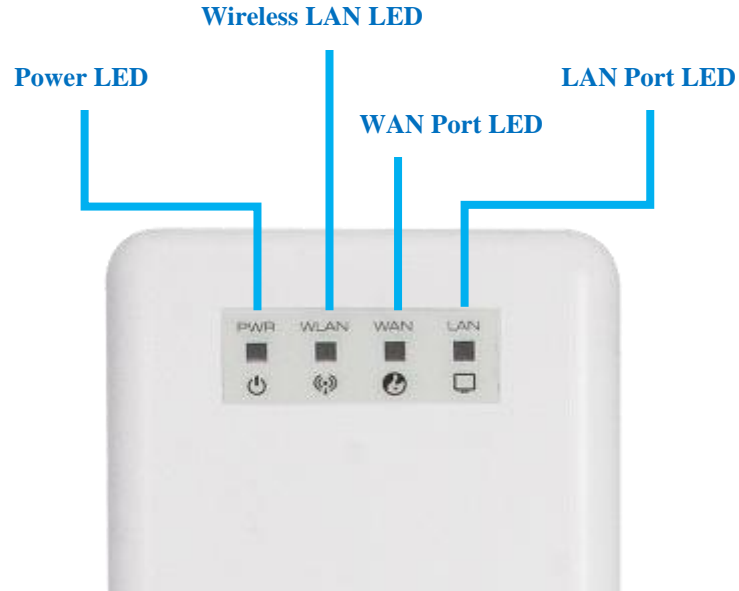

Figure 1-1 Rear Panel LED Identification

1.2 LED Indications

LED	State	Meaning
Power	On	System On
	Off	System Off
WLAN	On	Wireless Radio ON.
	Off	Wireless Radio Off.
	Blinking	Data is transmitting or receiving on the wireless.
WAN	On	Port linked.
	Off	No link.
	Blinking	Data is transmitting or receiving on the WAN interface.
LAN	On	Port linked.
	Off	No link.
	Blinking	Data is transmitting or receiving on the LAN interface.

1.3 The Rear Panel – Port & Connector

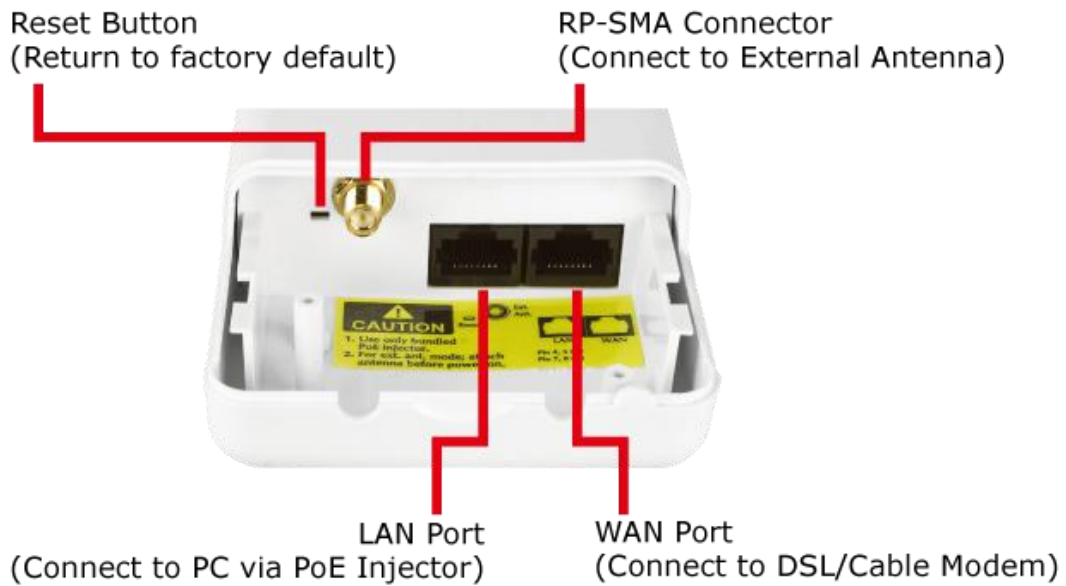

Figure 1-2 Port and Connector of DA2131-V1

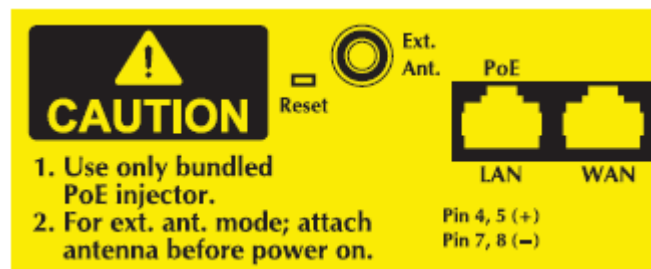

Figure 1-3 Port and Connector description label

Interface	Function
RP-SMA Connector	For external antenna. You can use the RP-SMA connector to connect a 2.4GHz external antenna (not supplied by Legrand).
LAN	The RJ-45 jack allows LAN connection through a Category 5 cable. Supports auto-sensing on 10/100M speed and half/ full duplex; complys with IEEE 802.3/ 802.3u respectively.
WAN	The RJ-45 jack allows WAN connection through a Category 5 cable. Supports auto-sensing on 10/100M speed and half/ full duplex; complys with IEEE 802.3/ 802.3u respectively.
Reset Button	Push and hold 5-10 seconds to reset unit to factory defaults.



1. For External Antenna Mode, you **MUST** physically attach antenna before powering on.
2. When using an external antenna, you should configure the **Antenna Switch** from “**Internal**” to “**External**” via Web UI.

1.4 PoE Injector

■ PoE Module



Figure 1-4 Top view of PoE Injector

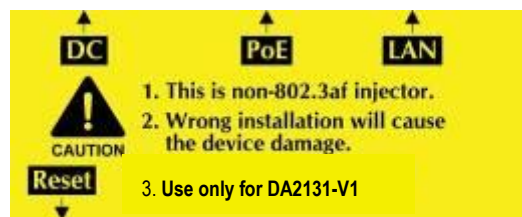

Figure 1-5 Label of PoE Injector

Chapter 2

Physical Installation

Physical Installation Steps

2.1 Preparation before Installation

2.1.1 Professional Installation Required

Please seek assistance from a professional installer who is well trained in Wireless data product installation and knowledgeable in the local regulations.

2.1.2 Safety Precautions

1. To keep you safe and install the hardware properly, please read and follow these safety precautions.
2. If you are installing the DA2131-V1A for the first time, for your safety as well as others', please seek assistance from a professional installer who has received safety training on the hazards involved.
3. Keep safety as well as performance in mind when selecting your installation site, especially where there are electric power and phone lines.
4. When installing the DA2131-V1A, please note the following things:
 - ◆ Do not use a metal ladder;
 - ◆ Do not work on a wet or windy day;
 - ◆ Wear shoes with rubber soles and heels, rubber gloves, long sleeved shirt or jacket.
5. When the system is operational, avoid standing directly in front of it. Strong RF fields are present when the transmitter is on.

2.1.3 Installation Precautions

To avoid damage to the DA2131-V1A while you are installing it, please read and follow these installation precautions.

1. Users **MUST** use a proper and well-installed surge arrestor with the DA2131-V1A; otherwise, a random lightening strike could easily cause fatal damage to the product. **EMD (Lightning) DAMAGE IS NOT COVERED UNDER WARRANTY.**
2. **Users MUST use the "Power cord & PoE Injector" shipped in the box with the DA2131-V1A.** Use of other options may cause damage to the product.
3. **Users MUST power off the DA2131-V1A first before connecting any external antenna to it.** Do not switch from built-in antenna to the external antenna from WEB management without physically attaching the external antenna onto the device first; otherwise, damage might be caused to the DA2131-V1A.

2.2 Hardware Installation

2.2.1 Installation Steps

Step 1. Push the latch in the bottom of DA2131-V1A to remove the sliding cover.

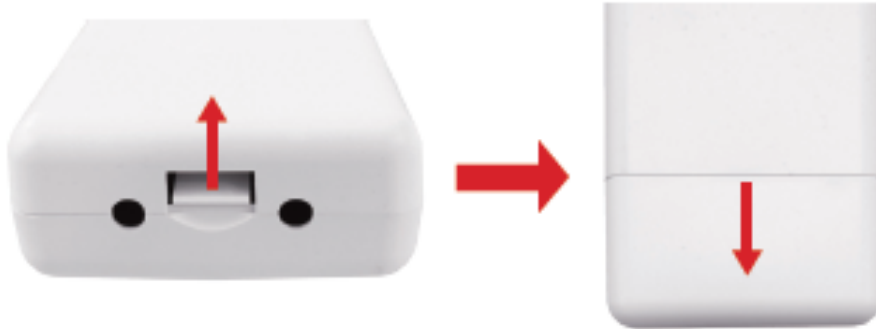

Figure 2-1 Move the cover

Step 2. Plug the RJ-45 Ethernet cable into the LAN Port of DA2131-V1A.



Figure 2-2 Cable Connection



RJ-45 8P8C Ethernet cable is required.

Step 3. Slide the cover back to seal the bottom of the DA2131-V1A.



Figure 2-3 Seal the bottom

Step 4. Take out the AC adapter and PoE injector, plug the power cord into the DC port and plug the other side of the RJ-45 cable from STEP 2 into the POE port of the PoE injector.

DC: Insert adapter DC power cord

POE: This jack is connected to LAN port of the Outdoor N-WAP with the supplied Cat5 cable.

LAN: This jack is connected to LAN side PC/Hub or Router/ADSL modem device with a Cat5 cable



Figure 2-4 Connect to PoE Injector

Step 5. Complete the hardware installation as indicated on the illustration below.



Figure 2-5 Cabling complete



It will take about 50 seconds to complete the boot up sequence after powering on the Outdoor N-WAP; Power LED will be active, and after that the WLAN Activity LED will be flashing to show the WLAN interface is enabled and working now.



To avoid lightning strike damage, consider installing a lightning arrestor between the NWAP and PoE injector.

2.2.2 Pole Mounting

Step 1. Turn the DA2131-V1A over. Feed a pole mounting tie through the middle hole of the rear

Step 2. Mount DA2131-V1A securely to the pole by fastening both mounting ties tightly.

Step 3. Now you have completed the hardware installation of DA2131-V1A as shown in the figure below.



Mounting Tie

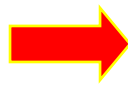

Figure 2-6 Pole Mounting

2.2.3 Surface Mounting

Notice the rear bracket flange of the DA2131-V1A contains a screw hole in each corner for mounting to a flat surface with appropriate screws (provided).

2.2.4 Using an External Antenna

If you prefer to use the external antenna with SMA-type connector for your application instead of the built-in directional antenna, please follow the steps below.

Step 1. Connect your antenna with the SMA-type connector on the bottom of DA2132-V1A.

Step 2. Power on the DA2131-V1A, and then go to **Wireless Settings-> Basic** to configure the **Antenna Switch** from “**Internal**” to “**External**”.



1. If you are going to use an external antenna on DA2131-V1A, get some cable in advance.
2. Users **MUST** power off the DA2131-V1A first before connecting the external antenna to it. **Do not switch from built-in antenna to the external antenna from WEB management without physically attaching the external antenna onto the DA2131-V1A**; otherwise, damage might be caused to the Outdoor NWAP itself.

Chapter 3

Network Settings

Configuring and monitoring your DA2131-V1A from a web browser

The DA2131-V1A integrates a web-based graphical user interface that can cover most configurations and machine status monitoring. Via a standard web browser, you can configure and check machine status from anywhere around the world.

NOTE: The DA2131-V1A comes from the factory with the following IP configuration:

Default IP Address: 192.168.40.252

Default IP Subnet Mask: 255.255.255.0

WEB login User Name; admin

WEB login Password: admin

3.1 Connecting to the Outdoor NWAP

For OS of Microsoft Windows 2000/ XP:

1. Click the **Start** button and select Settings, then click **Control Panel**. The **Control Panel** window will appear.
2. Move mouse and double-click the right button on **Network and Dial-up Connections** icon. Move mouse and double-click the **Local Area Connection** icon. The **Local Area Connection** window will appear. Click **Properties** button in the **Local Area Connection** window.



Figure 3-1

3. Check the installed list of **Network Components**. If TCP/IP is not installed, click the **Add** button to install it; otherwise go to step 6.

4. Select **Protocol** in the **Network Component Type** dialog box and click **Add** button.
5. Select **TCP/IP** in Microsoft of Select **Network Protocol** dialog box then click **OK** button to install the TCP/IP protocol, it may need the Microsoft Windows CD to complete the installation. Close and go back to **Network** dialog box after the TCP/IP installation.
6. Select **TCP/IP** and click the properties button on the **Network** dialog box.

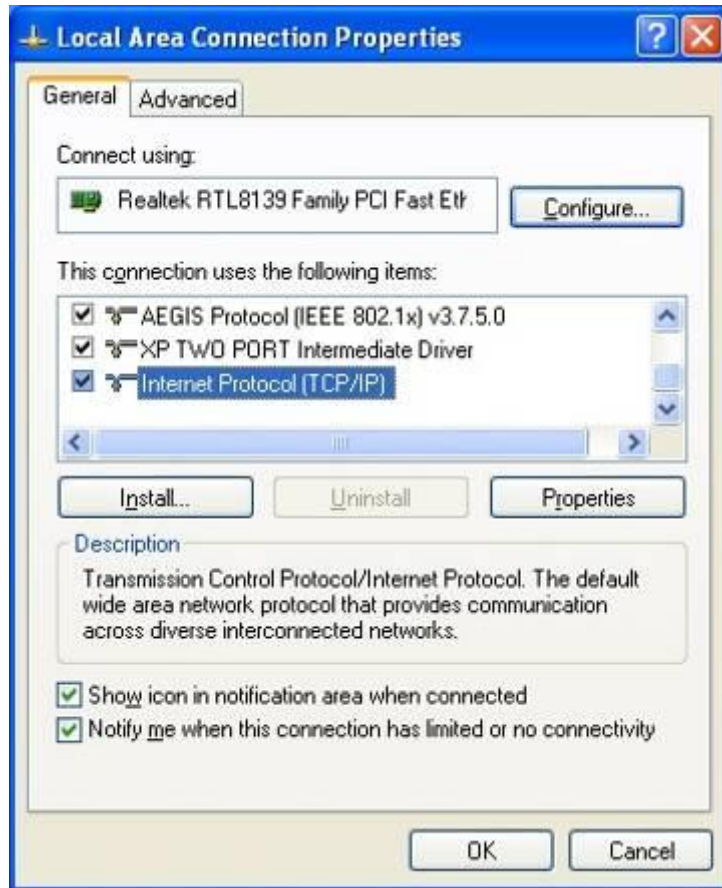

Figure 3-2

7. Select Specify an IP address and type in values as following example.
 IP Address: *192.168.40.2*, or any IP address within *192.168.40.2* to *192.168.40.251* is good to connect to the Outdoor NWAP.
 IP Subnet Mask: *255.255.255.0*

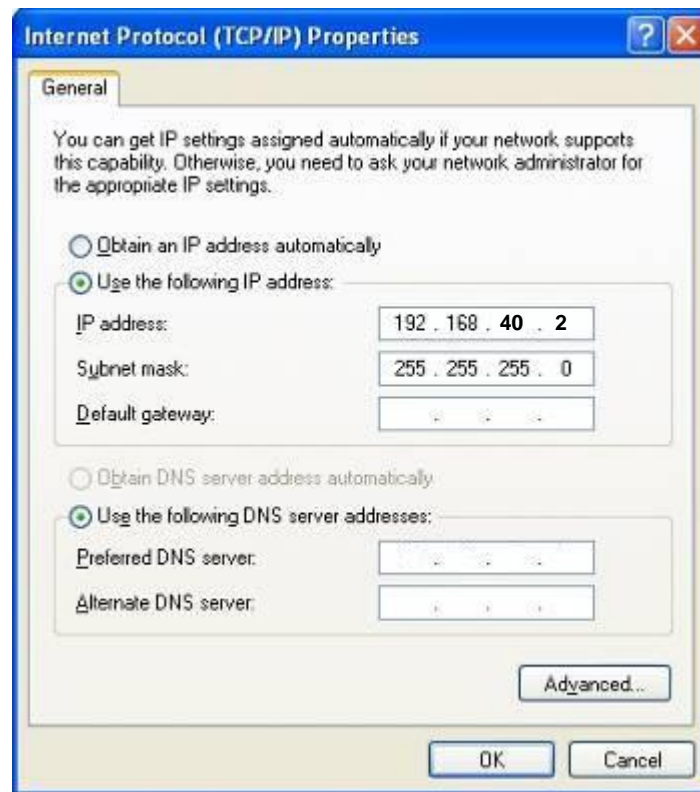

Figure 3-3

8. Click **OK** to complete the IP parameters setting.

For OS of Microsoft Windows Vista / 7:

1. Click the *Start* button and select *Settings*, then click **Control Panel**. The *Control Panel* window will appear.
2. Move mouse and double-click the right button on **Network Connections** item. The *Network Connections* window will appear. Double click **Local Area Connection icon**, then User Account Control window shown. Right click Continue button to set properties.
3. In *Local Area Connection Properties* window, Choose **Networking** tab, move mouse and click **Internet Protocol Version 4 (TCP/IPv4)**, then click *Properties* button.

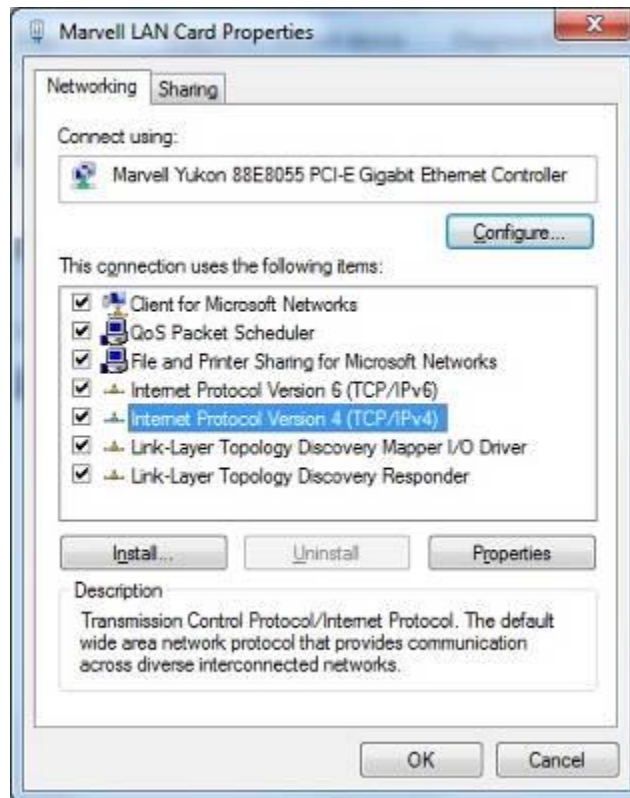

Figure 3-4

4. Move mouse and click **General** tab, Select **Specify an IP address** and type in values as following example.
 IP Address: *192.168.40.2*, or any IP address within *192.168.40.2* to *192.168.40.251* is good to connect to the Outdoor NWAP. IP Subnet Mask: *255.255.255.0*

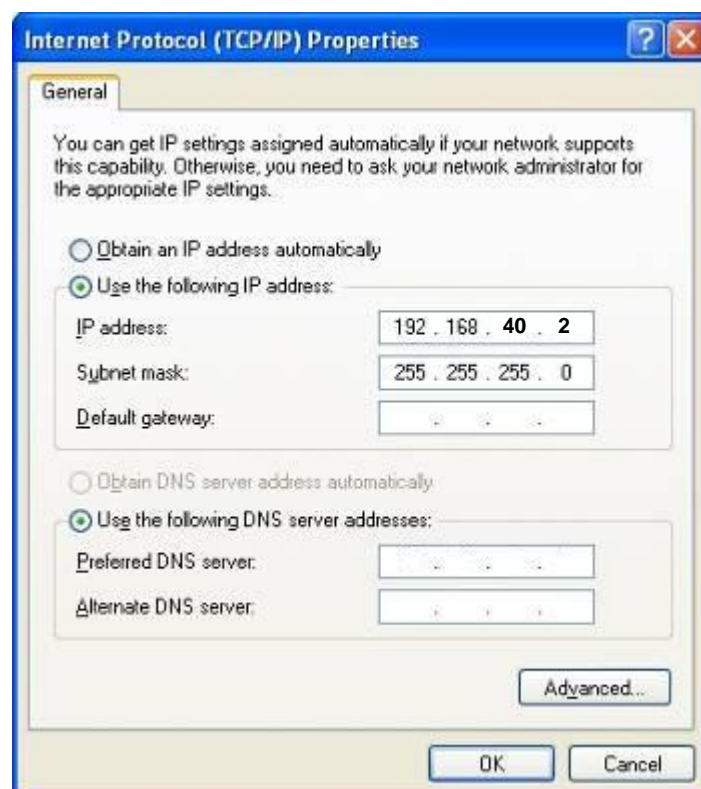

Figure 3-5

5. Click **OK** to complete the IP parameters setting.

For OS of Microsoft Windows NT:

1. Click the *Start* button and select Settings, then click *Control Panel*. The *Control Panel* window will appear.
2. Move mouse and double-click the right button on Network icon. The Network window will appear. Click Protocol tab from the Network window.
3. Check the installed list of Network Protocol window. If TCP/IP is not installed, click the Add button to install it; otherwise go to step 6.
4. Select Protocol in the Network Component Type dialog box and click Add button.
5. Select *TCP/IP* in *Microsoft of Select Network Protocol* dialog box then click OK button to install the TCP/IP protocol, it may need the Microsoft Windows CD to complete the installation. Close and go back to *Network* dialog box after the TCP/IP installation.
6. Select *TCP/IP* and click the properties button on the *Network* dialog box.
7. Select Specify an IP address and type in values as following example.
 IP Address: [192.168.40.2](#), or any IP address within [192.168.40.2](#) to [192.168.40.251](#) is good to connect to the Outdoor NWAP.
 IP Subnet Mask: [255.255.255.0](#)
8. Click *OK* to complete the IP parameters setting.

3.2 Web Login

Open a WEB browser, i.e. Microsoft Internet Explorer 6.1 SP1 or above, then enter [192.168.40.252](#) on the URL to connect the DA2131-V1A.

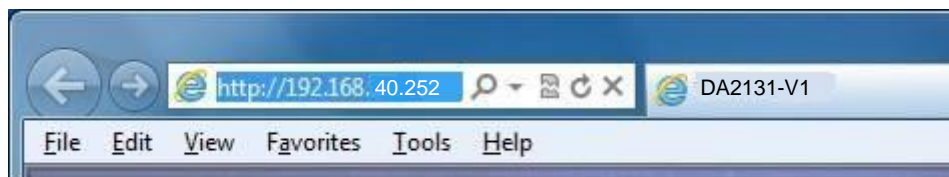

Figure 3-6

After a moment, a login window will appear. Enter the User Name and Password. Then click the **OK** button.



Figure 3-7 Login Window

Default User name: **admin**

Default Password: **admin**



If the above screen does not pop up, it may mean that your web-browser has been set to a proxy. Go to Tools menu>Internet Options>Connections>LAN Settings, in the screen that appears, cancel the Using Proxy checkbox, and click OK to finish it.

After you enter the username and password, the main screen appears as [Figure 3-8](#)

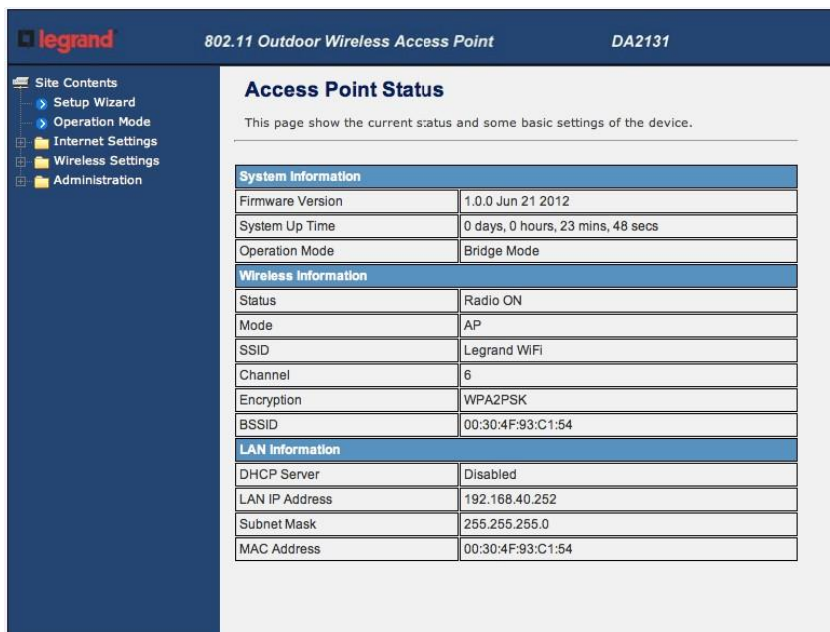

Figure 3-8 Web UI Screenshot

The next chapter will introduce the functions of the web UI.

Chapter 4. Basic System Settings

Setup Wizard

This Setup Wizard page guides you to configure the Internet connection and Wireless Settings quickly.

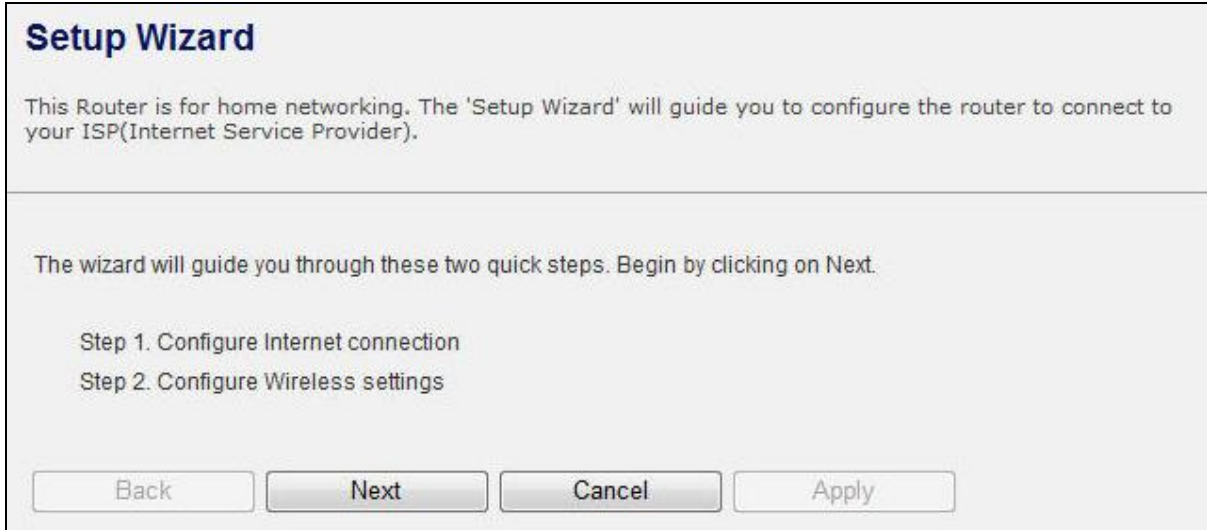

Figure 4-1 Setup Wizard

Click *Next* button to next step for Internet connection settings. There are five options (DHCP, Static Mode, PPPOE, L2TP, PPTP) for Internet connection on WAN port.

a. DHCP (Auto Config)

If your ISP provides the DHCP service, please choose **Dynamic IP** type, and the NWAP will automatically obtain IP parameters from your ISP. You can see the page as follows



Figure 4-2 Step 1. DHCP

The page includes the following fields:

Object	Description
Host Name	This option specifies the Host Name of the Router.

b. Static IP Address

If your ISP provides a static or fixed IP Address, Subnet Mask, Gateway and DNS setting, select **Static Mode (fixed IP)**. The Static IP settings page will appear, shown as following.

Setup Wizard

This Router is for home networking. The 'Setup Wizard' will guide you to configure the router to connect to your ISP(Internet Service Provider).

Step 1. Configure Internet Connection

WAN Connection Type: **Static Mode (fixed IP)**

Static Mode

IP Address	<input type="text"/>
Subnet Mask	<input type="text"/>
Default Gateway	<input type="text"/>
Primary DNS Server	<input type="text"/>
Secondary DNS Server	<input type="text"/>

Buttons: Back, Next, Cancel, Apply

Figure 4-3 Step 1. Static Mode

The page includes the following fields:

Object	Description
IP Address	Enter the IP address in dotted-decimal notation provided by your ISP.
Subnet Mask	Enter the subnet Mask in dotted-decimal notation provided by your ISP, usually is 255.255.255.0
Default Gateway	(Optional) Enter the gateway IP address in dotted-decimal notation provided by your ISP.
Primary/Secondary DNS	(Optional) Enter one or two DNS addresses in dotted-decimal notation provided by your ISP.

c. PPPOE Connection

If your ISP provides a PPPoE connection, select **PPPoE** option. And enter the following parameters.

Setup Wizard

This Router is for home networking. The 'Setup Wizard' will guide you to configure the router to connect to your ISP(Internet Service Provider).

Step 1. Configure Internet Connection

WAN Connection Type: PPPOE (ADSL)

PPPoE Mode	
User Name	<input style="width: 90%;" type="text"/>
Password	<input style="width: 90%;" type="password"/>
Verify Password	<input style="width: 90%;" type="password"/>
Operation Mode	<div style="margin-bottom: 5px;">Keep Alive ▼</div> <div style="margin-bottom: 5px;">Keep Alive Mode: Redial Period <input style="width: 40px; text-align: center;" type="text" value="60"/> seconds</div> <div>On demand Mode: Idle Time <input style="width: 40px; text-align: center;" type="text" value="5"/> minutes</div>

Back
Next
Cancel
Apply

Figure 4-4 Step 1. PPPOE

The page includes the following fields:

Object	Description
User Name/Password	Enter the User Name and Password provided by your ISP. These fields are case-sensitive.
Verify Password	Fill in the password again for verification.
Operation Mode	<ul style="list-style-type: none"> ■ Keep Alive: Keep the PPPoE connection all the time. Please also configure the Redial Period field. ■ On Demand: Please configure the Idle Time field. When time is up, the PPPoE connection will disconnect. The connection will re-connect when any outgoing packet arise. ■ Manual: Let user connect the PPPoE connection manually.

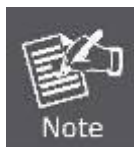

Sometimes the connection cannot be terminated although you specify a time to Idle Time, since some applications are visiting the Internet continually in the background.

d. L2TP

If your ISP provides L2TP connection, please select **L2TP** option. And enter the following parameters.

Setup Wizard

This Router is for home networking. The 'Setup Wizard' will guide you to configure the router to connect to your ISP(Internet Service Provider).

Step 1. Configure Internet Connection

WAN Connection Type: L2TP

L2TP Mode	
L2TP Server IP Address	<input style="width: 100%;" type="text"/>
User Name	<input style="width: 80%;" type="text"/>
Password	<input style="width: 80%;" type="password"/>
Address Mode	Static
IP Address	<input style="width: 100%;" type="text"/>
Subnet Mask	<input style="width: 100%;" type="text"/>
Default Gateway	<input style="width: 100%;" type="text"/>
Operation Mode	Keep Alive
Keep Alive Mode: Redial Period <input style="width: 40px; text-align: center;" type="text" value="60"/> seconds	

Back
Next
Cancel
Apply

Figure 4-5 Step 1. L2TP

The page includes the following fields:

Object	Description
L2TP Server IP Address	Allow user to make a tunnel with remote site directly to secure the data transmission among the connection. User can use embedded L2TP client supported by this router to make a VPN connection. If you select the L2TP support on WAN interface, fill in the IP address for it.
User Name/Password	Enter the User Name and Password provided by your ISP. These fields are case-sensitive.
Address Mode	<ul style="list-style-type: none"> ■ Static: To configure the IP address information by manually, please fill in the related setting at below. ■ Dynamic: The option allows the machine to get IP address information automatically from DHCP server on WAN side.

IP Address	Fill in the IP address for WAN interface.
Subnet Mask	Fill in the subnet mask for WAN interface.
Default Gateway	Fill in the default gateway for WAN interface out going data packets.
Operation Mode	<ul style="list-style-type: none"> ■ Keep Alive: Keep the L2TP connection all the time. Please also configure the Redial Period field. ■ Manual: Let user connect the L2TP connection manually.

e. PPTP

If your ISP provides PPTP connection, please select **PPTP** option. And enter the following parameters.

Setup Wizard

This Router is for home networking. The 'Setup Wizard' will guide you to configure the router to connect to your ISP(Internet Service Provider).

Step 1. Configure Internet Connection

WAN Connection Type: PPTP ▼

PPTP Mode	
PPTP Server IP Address	<input style="width: 100%;" type="text"/>
User Name	<input style="width: 80%;" type="text"/>
Password	<input style="width: 80%;" type="password"/>
Address Mode	Static ▼
IP Address	<input style="width: 100%;" type="text"/>
Subnet Mask	<input style="width: 100%;" type="text"/>
Default Gateway	<input style="width: 100%;" type="text"/>
Operation Mode	Keep Alive ▼
Keep Alive Mode: Redial Period <input style="width: 40px; text-align: center;" type="text" value="60"/> seconds	

Back
Next
Cancel
Apply

Figure 4-6 Step1. PPTP

The page includes the following fields:

Object	Description
PPTP Server IP Address	<p>Allow user to make a tunnel with remote site directly to secure the data transmission among the connection. User can use embedded PPTP client supported by this router to make a VPN connection.</p> <p>If you select the PPTP support on WAN interface, fill in the IP address for it.</p>
User Name/Password	<p>Enter the User Name and Password provided by your ISP. These fields are case-sensitive.</p>
Address Mode	<p>Static: To configure the IP address information by manually, please fill in the related setting at below.</p> <p>Dynamic: The option allows the machine to get IP address information automatically from DHCP server on WAN side.</p>
IP Address	<p>Fill in the IP address for WAN interface.</p>
Subnet Mask	<p>Fill in the subnet mask for WAN interface.</p>
Default Gateway	<p>Fill in the default gateway for WAN interface out going data packets.</p>
Operation Mode	<p>Keep Alive: Keep the PPTP connection all the time. Please also configure the Redial Period field.</p> <p>Manual: Let user connect the PPTP connection manually.</p>

When you finish these settings, then click *Next* button to jump at Step2.

Step 2: configure Wireless Settings

There are five options (Disable, OPENWEP, SHAREDWEP, WPA-PSK, WPA2-PSK) for Wireless security connection.



Figure 4-7 Step 2. Configure Wireless Settings

Object	Description
Network Mode	This field determines the wireless mode which the NWAP works on.
Frequency (Channel)	This field determines which operating frequency will be used. The default channel is set to AutoSelect , so the NWAP will choose the best channel automatically. It is not necessary to change the wireless channel unless you notice interference problems with another nearby access point.
Network Name (SSID)	Enter a value of up to 32 characters. The same name of SSID (Service Set Identification) must be assigned to all wireless devices in your network. The default SSID is set to be Legrand WiFi. This value is case-sensitive. For example, <i>LEGRAND</i> is NOT the same as Legrand.
Channel Bandwidth	Select the operating channel width 20 MHz or 20/40 MHz.
Security Mode	<ul style="list-style-type: none"> ■ Disable: No security required ■ OPENWEP / SHAREDWEP: When you select WEP, please input 5, 13 (ASCII), 10 or 26 (HEX) characters for WEP Key. ■ WPA-PSK / WPA2-PSK: You can enter ASCII characters between 8 and 63 characters or 8 to 64 Hexadecimal characters.

When you finish these settings, then click **Apply** button to save.

4.2 Operation Mode

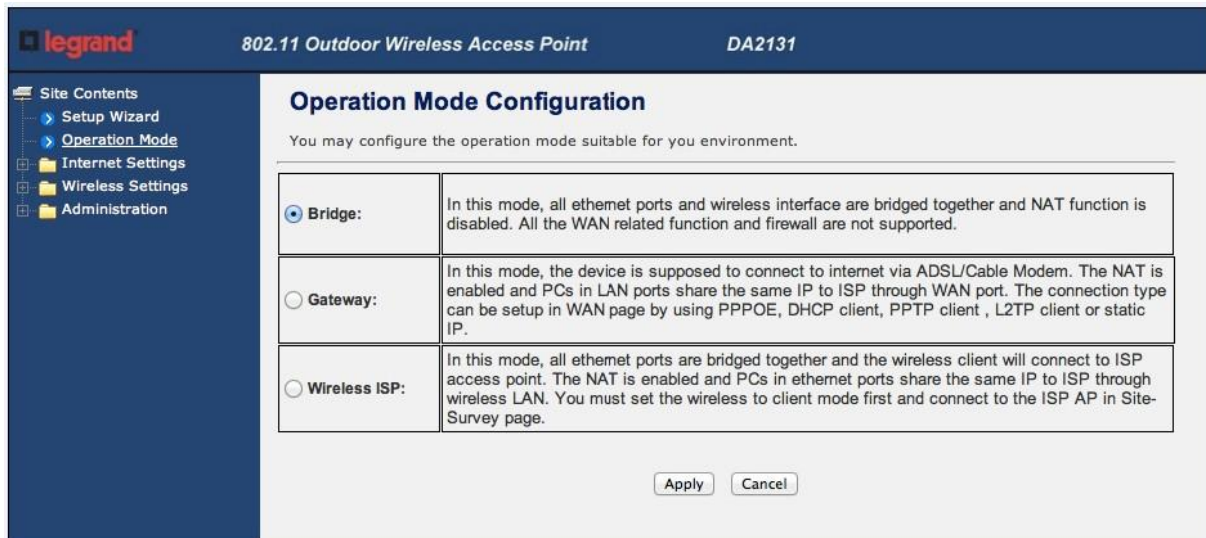

Figure 4-8 Operation Mode Configurations

a. Bridge:

The **Bridge** mode allows that all Ethernet and wireless interfaces are bridged into a single **Bridge** interface.

b. Gateway:

The **Gateway** mode allows that the first Ethernet port is treated as WAN port and the Ethernet port and the wireless interface are bridged together and are treated as LAN ports.

c. Wireless ISP:

The **Wireless ISP** mode allows that the wireless interface is treated as WAN port, and the Ethernet ports are LAN ports.

4.3 Internet Settings

4.3.1 WAN

Wide Area Network (WAN) Settings

You may choose different connection type suitable for your environment. Besides, you may also configure parameters according to the selected connection type.

WAN Connection Type: DHCP (Auto config) ▾

DHCP Mode

Hostname (optional)	
MAC Clone	
Enabled	Disable ▾

Apply
Cancel

Figure 4-9 WAN Settings

a. STATIC

Object	Description
IP Address	Enter the IP address in dotted-decimal notation provided by your ISP.
Subnet Mask	Enter the subnet Mask in dotted-decimal notation provided by your ISP, usually is 255.255.255.0
Default Gateway	(Optional) Enter the gateway IP address in dotted-decimal notation provided by your ISP.
Primary/Secondary DNS	(Optional) Enter one or two DNS addresses in dotted-decimal notation provided by your ISP.

b. DHCP

Object	Description
Host Name	This option specifies the Host Name of the Router.
MAC Clone	Take NIC MAC address of PC on LAN side as the MAC address of WAN interface.

c. PPPoE

Object	Description
User Name/Password	Enter the User Name and Password provided by your ISP. These fields are case-sensitive.
Verify Password	Fill in the password again for verification.
Operation Mode	<p>Keep Alive: Keep the PPPoE connection all the time. Please also configure the Redial Period field.</p> <p>On Demand: Please configure the Idle Time field. When time is up, the PPPoE connection will disconnect. The connection will re-connect when any outgoing packet arise.</p> <p>Manual: Let user connect the PPPoE connection manually.</p>

d. L2TP

Object	Description
L2TP Server IP Address	<p>Allow user to make a tunnel with remote site directly to secure the data transmission among the connection. User can use embedded L2TP client supported by this router to make a VPN connection.</p> <p>If you select the L2TP support on WAN interface, fill in the IP address for it.</p>
User Name/Password	Enter the User Name and Password provided by your ISP. These fields are case-sensitive.
Address Mode	<ul style="list-style-type: none"> ■ Static: To configure the IP address information by manually, please fill in the related setting at below. ■ Dynamic: The option allows the machine to get IP address information automatically from DHCP server on WAN side.
IP Address	Fill in the IP address for WAN interface.
Subnet Mask	Fill in the subnet mask for WAN interface.
Default Gateway	Fill in the default gateway for WAN interface out going data packets.
Operation Mode	<ul style="list-style-type: none"> ■ Keep Alive: Keep the L2TP connection all the time. Please also configure the Redial Period field. ■ Manual: Let user connect the L2TP connection manually.

e. PPTP

Object	Description
PPTP Server IP Address	Allow user to make a tunnel with remote site directly to secure the data transmission among the connection. User can use embedded PPTP client supported by this router to make a VPN connection.

	If you select the PPTP support on WAN interface, fill in the IP address for it.
User Name/Password	Enter the User Name and Password provided by your ISP. These fields are case-sensitive.
Address Mode	<ul style="list-style-type: none"> ■ Static: To configure the IP address information by manually, please fill in the related setting at below. ■ Dynamic: The option allows the machine to get IP address information automatically from DHCP server on WAN side.
IP Address	Fill in the IP address for WAN interface.
Subnet Mask	Fill in the subnet mask for WAN interface.
Default Gateway	Fill in the default gateway for WAN interface out going data packets.
Operation Mode	<ul style="list-style-type: none"> ■ Keep Alive: Keep the PPTP connection all the time. Please also configure the Redial Period field. ■ Manual: Let user connect the PPTP connection manually.

4.3.2 LAN

The screenshot shows the web interface for the Legrand 802.11 Outdoor Wireless Access Point DA2131. The page title is "Local Area Network (LAN) Settings". Below the title, there is a brief instruction: "You may enable/disable networking functions and configure their parameters as your wish." The main content is a table titled "LAN Setup" with the following fields:

LAN Setup	
MAC Address	00:30:4F:93:C1:54
IP Address	192.168.40.252
Subnet Mask	255.255.255.0
DHCP Type	Disable
Lease Time	86400
802.1d Spanning Tree	Disable
LLTD	Disable
IGMP Proxy	Disable
UPNP	Enable
Router Advertisement	Disable
PPPoE Relay	Disable
DNS Proxy	Disable

At the bottom of the table, there are "Apply" and "Cancel" buttons.

Figure 4-10 LAN Settings

The page includes the following fields:

Object	Description
MAC Address	The physical address of the NWAP, as seen from the LAN. The value can't be changed.
IP Address	Enter the IP address of your NWAP or reset it in dotted-decimal notation (factory default: 192.168.40.252).
Subnet Mask	An address code that determines the size of the network. Normally use 255.255.255.0 as the subnet mask.
Default Gateway	Fill in the default gateway for LAN interfaces out going data packets.
DHCP Type	<ul style="list-style-type: none"> ■ Disable: Disable DHCP server on LAN side. ■ Server: Enable DHCP server on LAN side.
Start IP Address	Fill in the start IP address to allocate a range of IP addresses; client with DHCP function set will be assigned an IP address from the range.
End IP Address	Fill in the end IP address to allocate a range of IP addresses; client with DHCP function set will be assigned an IP address from the range.
Lease Time	Fill in the lease time of DHCP server function.
802.1d Spanning Tree	Select enable or disable the IEEE 802.1d Spanning Tree function from pull-down menu.
LLTD	Select enable or disable the Link Layer Topology Discover function from pull-down menu.
IGMP Proxy	Select enable or disable the IGMP proxy function from pull-down menu.
UPNP	Select enable or disable the UPnP protocol from pull-down menu.
DNS Proxy	Select enable or disable the DNS Proxy function from pull-down menu.



4.3.3 DHCP Clients

The “DHCP clients” page shows all the active DHCP clients. The table window shows the active clients with their Hostname, MAC address, assigned IP address, and time expired information.

DHCP Clients			
Hostname	MAC Address	IP Address	Expires in
ENM-MIKI	00:30:4F:15:54:A6	192.168.1.102	23:59:53

Figure 4-11 DHCP Clients

4.3.4 VPN Passthrough

VPN Pass Through	
L2TP Passthrough	Enable ▾
IPSec Passthrough	Enable ▾
PPTP Passthrough	Enable ▾

Figure 4-12 VPN Passthrough

The page includes the following fields:

Object	Description
L2TP Passthrough	Select enable or disable the L2TP pass-through function from pull-down menu.
IPSec Passthrough	Select enable or disable the IPSec pass-through function from pull-down menu.
PPTP Passthrough	Select enable or disable the PPTP pass-through function from pull-down menu.

4.4 Wireless

4.4.1 Basic

legrand 802.11 Outdoor Wireless Access Point DA2131

Basic Wireless Settings

You could configure the minimum number of Wireless settings for communication, such as Network Name (SSID) and Channel. The Access Point can be set simply with only the minimum setting items.

Wireless Network	
Wireless On/Off	Wireless OFF Current Status:Radio ON
Antenna Switch	<input type="radio"/> External <input checked="" type="radio"/> Internal
Wireless Mode	AP
Wireless Band	802.11B/G/N
SSID	Legrand WiFi
Broadcast Network Name (SSID)	<input checked="" type="radio"/> Enabled <input type="radio"/> Disabled
AP Isolation	<input type="radio"/> Enabled <input checked="" type="radio"/> Disabled
BSSID	00:30:4F:93:C1:54
Frequency (Channel)	2437MHz (Channel 6) Current Channel: 6
HT Physical Mode	
Operating Mode	<input checked="" type="radio"/> Mixed Mode <input type="radio"/> Green Field
Channel BandWidth	<input type="radio"/> 20 <input checked="" type="radio"/> 20/40
Guard Interval	<input type="radio"/> Long <input checked="" type="radio"/> Auto
MCS	Auto
Extension Channel	2457MHz (Channel 10)

Apply Cancel

Figure 4-13 Basic Wireless Settings

The page includes the following fields:

Object	Description
Wireless On/Off	Click Wireless OFF button to turn off wireless RF radio. Click Wireless ON button to turn on wireless RF radio.
Antenna Switch	Select Internal antenna or External antenna for using. The default is using Internal antenna.
Wireless Mode	Click to select wireless mode from pull down menu.
SSID	It is the wireless network name. The SSID can be 32 bytes long. User can use the default SSID or change it.

Broadcast Network Name (SSID)	Enable or disable the SSID broadcast function.
AP Isolation	<p>Wireless network is similar to the virtual local area network. All of the Wireless client devices can access each other completely.</p> <p>When you enable this function, it will turn off connection between wireless clients. Only allows connection between wireless client and this AP router.</p>
MBSSID AP Isolation	Enable this function will turn off connection between clients with different MBSSID. Example: The client connected with BSSID 1. When enable this function, it will not connect with BSSID 2. Only can access between clients with SSID 1.
BSSID	Show the MAC address of Wireless interface.
Frequency (Channel)	Select the wireless communication frequency/channel from pull-down menu.
Operating Mode	Select "Mixed Mode" for 11b/g/n mode or "Green Field" for 11n mode.
Channel BandWidth	Select the operating channel width 20 MHz or 20/40 MHz.
Guard Interval	Select "Long" or "Auto". Guard intervals are used to ensure that distinct transmissions do not interfere with one another. Only effect under Mixed Mode.
MCS	Select 0~7 or "Auto" from pull down menu. The default is "Auto". Only effect under Mixed Mode.

4.4.2 Advanced

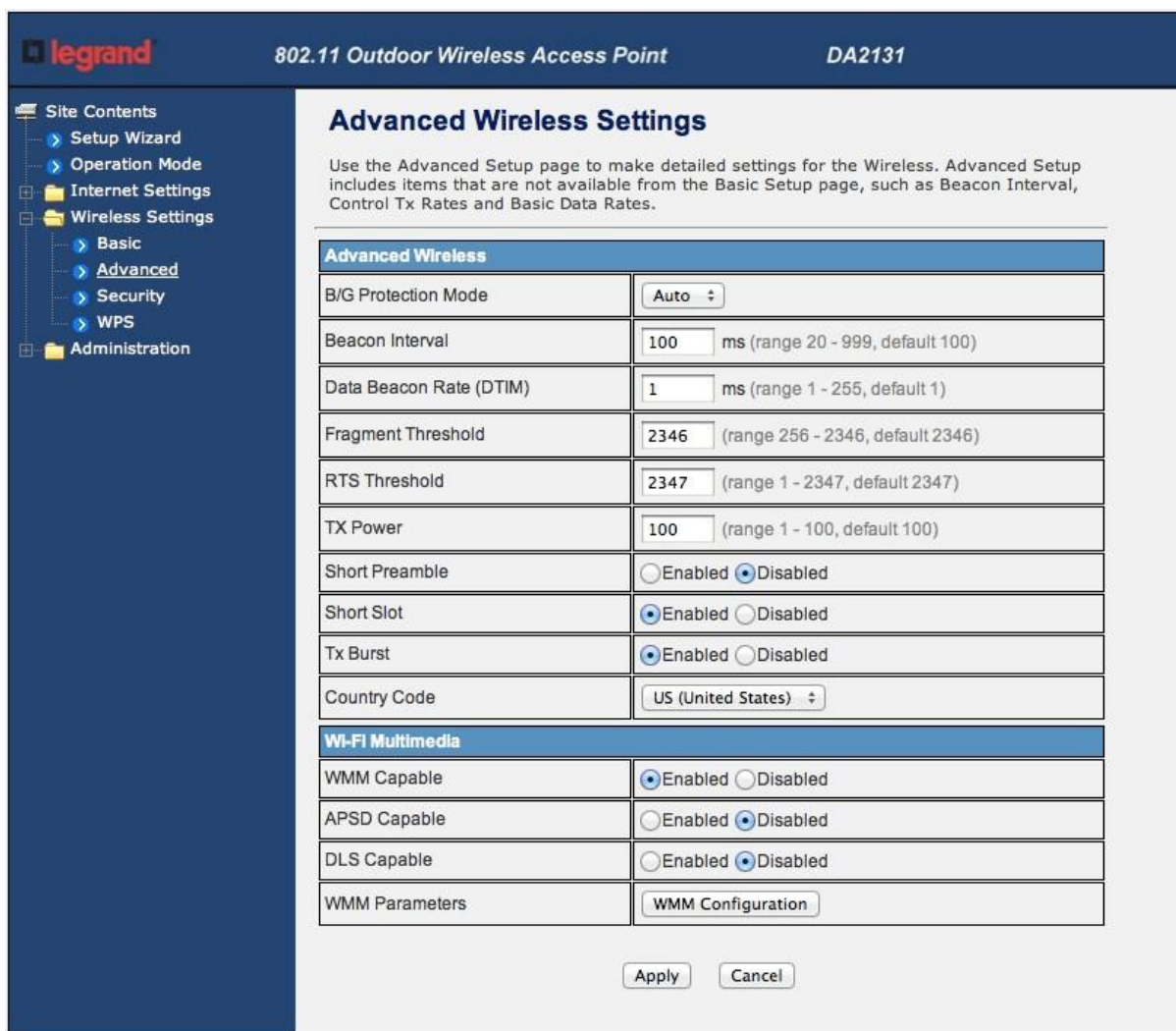

Figure 4-14 Advanced Wireless Settings

The page includes the following fields:

Object	Description
B/G Protection Mode	Default: Auto . You can select the other options including On and Off . The B/G protection technology is CTS-To-Self. It will try to reserve the throughput for 11g clients from 11b clients connecting to the device as AP mode.
Beacon Interval	Beacons are the packets sending by Access point to synchronize the wireless network. The beacon interval is the time interval between beacons sending by this unit in AP or AP+WDS operation. The default and recommended beacon interval is 100 milliseconds.
Data Beacon Rate(DTM)	This is the Delivery Traffic Indication Map. It is used to alert the clients that multicast and broadcast packets buffered at the AP will be transmitted immediately after the transmission of this beacon frame. You can change the value from 1 to 255. The AP will check the

	buffered data according to this value. For example, selecting "1" means to check the buffered data at every beacon.
Fragment Threshold	The fragmentation threshold determines the size at which packets are fragmented (sent as several pieces instead of as one block). Use a low setting in areas where communication is poor or where there is a great deal of radio interference. This function will help you to improve the network performance.
RTS Threshold	The RTS threshold determines the packet size at which the radio issues a request to send (RTS) before sending the packet. A low RTS Threshold setting can be useful in areas where many client devices are associating with the device, or in areas where the clients are far apart and can detect only the device and not each other. You can enter a setting ranging from 0 to 2347 bytes.
TX Power	The default TX power is 100%. In case of shortening the distance and the coverage of the wireless network, input a smaller value to reduce the radio transmission power. For example, input 80 to apply 80% Tx power.
Short Preamble	Default: Disable. It is a performance parameter for 802.11 b/g mode and not supported by some of very early stage of 802.11b station cards. If there is no such kind of stations associated to this AP, you can enable this function.
Short Slot	It is used to shorten the communication time between this AP and station.
TX Burst	The device will try to send a serial of packages with single ACK reply from the clients. Enable this function to apply it.
Country Code	Select the country code for wireless from pull down menu.



4.4.3 Security

a. Disable



Figure 4-15 Wireless Security Settings

If you set Security Mode to “**Disable**”, the wireless data transmission will not include encryption to prevent from unauthorized access and monitoring.

b. OPEN-WEP

Wireless Security/Encryption Settings

Setup the wireless security and encryption to prevent from unauthorized access and monitoring.

Security Wireless

Security Mode	OPEN-WEP ▾
---------------	------------

Wire Equivalence Protection (WEP)

Default Key	Key 1 ▾
-------------	---------

WEP Keys	WEP Key 1 :	<input type="text"/>	Hex ▾
	WEP Key 2 :	<input type="text"/>	Hex ▾
	WEP Key 3 :	<input type="text"/>	Hex ▾
	WEP Key 4 :	<input type="text"/>	Hex ▾

Access Policy

Policy	Disabled ▾
--------	------------

Add a station Mac:	<input type="text"/>
--------------------	----------------------

Figure 4-16 OPEN-WEP

If you set Security Mode to “**OPEN-WEP**” or “**SHARED-WEP**”, please fill in the related configurations at below.

Object	Description
Default Key	Specify a Key number for effective.
WEP Keys (1~4)	When you select the encryption type as WEP, please input 5, 13 (ASCII), 10 or 26 (HEX) characters for WEP Key.

C. SHARED-WEP

Wireless Security/Encryption Settings

Setup the wireless security and encryption to prevent from unauthorized access and monitoring.

Security Wireless

Security Mode	SHARED-WEP ▾
---------------	--------------

Wire Equivalence Protection (WEP)

Default Key	Key 1 ▾
-------------	---------

WEP Keys	WEP Key 1 :	<input type="text"/>	Hex ▾
	WEP Key 2 :	<input type="text"/>	Hex ▾
	WEP Key 3 :	<input type="text"/>	Hex ▾
	WEP Key 4 :	<input type="text"/>	Hex ▾

Access Policy

Policy	Disabled ▾
Add a station Mac:	<input type="text"/>

Figure 4-17 SHARED-WEP

If you set Security Mode to “**OPEN-WEP**” or “**SHARED-WEP**”, please fill in the related configurations at below.

Object	Description
Default Key	Specify a Key number for effective.
WEP Keys (1~4)	When you select the encryption type as WEP, please input 5, 13 (ASCII), 10 or 26 (HEX) characters for WEP Key.

d. WPA-RADIUS

Wireless Security/Encryption Settings

Setup the wireless security and encryption to prevent from unauthorized access and monitoring.

Security Wireless

Security Mode	<input type="text" value="WPA-RADIUS"/>
---------------	---

WPA

WPA Cipher Suite	<input type="radio"/> TKIP <input checked="" type="radio"/> AES <input type="radio"/> TKIPAES
Key Renewal Interval	<input type="text" value="3600"/> seconds (60 ~ 9999)

Radius Server

IP Address	<input type="text" value="0"/>
Port	<input type="text" value="1812"/>
Shared Secret	<input type="text" value="ralink"/>
Session Timeout	<input type="text" value="0"/>
Idle Timeout	<input type="text"/>

Figure 4-18 WPA-RADIUS

The page includes the following fields:

Object	Description
WPA Cipher Suite	Select TKIP , AES or TKIPAES for WPA algorithms.
Key Renewal Interval	Please fill in a number for Group Key Renewal interval time.
IP Address	Enter the RADIUS Server's IP Address provided by your ISP.
Port	Enter the RADIUS Server's port number provided by your ISP. (The Default is 1812.)
Shared Secret	Enter the password that the Wireless Router shares with the RADIUS Server.
Session Timeout	Session timeout interval is for 802.1x re-authentication setting. Set to zero to disable 802.1x re-authentication service for each session. Session timeout interval unit is second and must be larger than 60.
Idle Timeout	Enter the idle timeout in the column.

e. WPA-PSK

Wireless Security/Encryption Settings

Setup the wireless security and encryption to prevent from unauthorized access and monitoring.

Security Wireless

Security Mode	WPA-PSK ▼
---------------	-----------

WPA

WPA Cipher Suite	<input type="radio"/> TKIP <input checked="" type="radio"/> AES <input type="radio"/> TKIPAES
Pre-Shared Key	<input style="width: 90%;" type="text"/>
Key Renewal Interval	<input style="width: 50%;" type="text" value="3600"/> seconds (60 ~ 9999)

Access Policy

Policy	Disabled ▼
Add a station Mac:	<input style="width: 90%;" type="text"/>

Figure 4-19 WPA-PSK

The page includes the following fields:

Object	Description
WPA Cipher Suite	Select TKIP , AES or TKIPAES for WPA algorithms.
Pre-Shared Key	Please fill in a passphrase like 'test wpa 123', or a hexadecimal string like '65E4 E123 456 E1'.
Key Renewal Interval	Please fill in a number for Group Key Renewal interval time.

f. WPA2-RADIUS

Wireless Security/Encryption Settings

Setup the wireless security and encryption to prevent from unauthorized access and monitoring.

Security Wireless

Security Mode	WPA2-RADIUS ▾
---------------	---------------

WPA

WPA Cipher Suite	<input type="radio"/> TKIP <input checked="" type="radio"/> AES <input type="radio"/> TKIPAES
Key Renewal Interval	3600 seconds (60 ~ 9999)
PMK Cache Period	10 minute
Pre-Authentication	<input checked="" type="radio"/> Disable <input type="radio"/> Enable

Radius Server

IP Address	0
Port	1812
Shared Secret	ralink!
Session Timeout	0
Idle Timeout	

Figure 4-20 WPA2-RADIUS

The page includes the following fields:

Object	Description
WPA Cipher Suite	Select TKIP , AES or TKIPAES for WPA algorithms.
Key Renewal Interval	Please fill in a number for Group Key Renewal interval time.
PMK Cache Period	Only valid in WPA2 security. Set WPA2 PMKID cache timeout period, after time out, the cached key will be deleted. PMK Cache Period unit is minute.
Pre-Authentication	Only valid in WPA2 security. The most important features beyond WPA to become standardized through 802.11i/WPA2 are: Pre-authentication, which enables secure fast roaming without noticeable signal latency.
Shared Secret	Enter the password that the Wireless Router shares with the RADIUS Server.

Session Timeout	Session timeout interval is for 802.1x re-authentication setting. Set to zero to disable 802.1x re-authentication service for each session. Session timeout interval unit is second and must be larger than 60.
IP Address	Enter the RADIUS Server's IP Address provided by your ISP.
Port	Enter the RADIUS Server's port number provided by your ISP. (The Default is 1812.)
Shared Secret	Enter the password that the Wireless Router shares with the RADIUS Server.
Session Timeout	Session timeout interval is for 802.1x re-authentication setting. Set to zero to disable 802.1x re-authentication service for each session. Session timeout interval unit is second and must be larger than 60.
Idle Timeout	Enter the idle timeout in the column.

g. WPA2-PSK

Wireless Security/Encryption Settings

Setup the wireless security and encryption to prevent from unauthorized access and monitoring.

Security Wireless

Security Mode	WPA2-PSK ▾
---------------	------------

WPA

WPA Cipher Suite	<input type="radio"/> TKIP <input checked="" type="radio"/> AES <input type="radio"/> TKIPAES
Pre-Shared Key	<input style="width: 100%;" type="text"/>
Key Renewal Interval	<input style="width: 50px;" type="text" value="3600"/> seconds (60 ~ 9999)

Access Policy

Policy	Disabled ▾
Add a station Mac:	<input style="width: 100%;" type="text"/>

Figure 4-21 WPA2-PSK

The page includes the following fields:

Object	Description
WPA Cipher Suite	Select TKIP , AES or TKIPAES for WPA algorithms.
Pre-Shared Key	Please fill in a passphrase like 'test wpa 123', or a hexadecimal string like '65E4 E123 456 E1'.
Key Renewal Interval	Please fill in a number for Group Key Renewal interval time.

h. 802.1X

Wireless Security/Encryption Settings

Setup the wireless security and encryption to prevent from unauthorized access and monitoring.

Security Wireless

Security Mode	802.1X ▼
---------------	----------

802.1x WEP

WEP	<input type="radio"/> Disable <input type="radio"/> Enable
-----	--

Radius Server

IP Address	0
Port	1812
Shared Secret	ralink
Session Timeout	0
Idle Timeout	

Access Policy

Figure 4-22 802.1X

The page includes the following fields:

Object	Description
WEP	Enable or Disable WEP encryption.
IP Address	Enter the RADIUS Server's IP Address provided by your ISP.
Port	Enter the RADIUS Server's port number provided by your ISP. (The Default is 1812.)
Shared Secret	Enter the password that the Wireless Router shares with the RADIUS Server.
Session Timeout	Session timeout interval is for 802.1x re-authentication setting. Set to zero to disable 802.1x re-authentication service for each session. Session timeout interval unit is second and must be larger than 60.
Idle Timeout	Enter the idle timeout in the column.

e. Access Policy

Wireless Security/Encryption Settings

Setup the wireless security and encryption to prevent from unauthorized access and monitoring.

Security Wireless

Security Mode	Disable ▾
---------------	-----------

Access Policy

Policy	Allow ▾
1	00:30:4F:15:54:A6 <input type="button" value="Del"/>
Add a station Mac:	<input style="width: 100%;" type="text"/>

Figure 4-23 Access Policy

The page includes the following fields:

Object	Description
Policy	Select the Disabled, Allow or Reject of drop down menu choose wireless access control mode. This is a security control function; only those clients registered in the access control list can link to this NWAP.
Add a station MAC	Fill in the MAC address of client to register this AP router access capability.

5.4.4 WDS

In the Basic Wireless Settings page, select the Wireless Mode to “WDS” to setup the WDS connection.

a. WDS Mode

WDS mode allows user to operate as a standard WDS that forwards traffic between WDS links (links that connect to other units in Repeater). The MAC addresses of WDS peers must be configured on the Wireless 11n Access Points/ Repeaters. Basically this mode is used when you have a 2.4GHz outdoor router with more than one WDS link to other AP/Repeaters.

Note: In this mode wireless clients will not be able to connect to the 2.4GHz outdoor router directly.

Step 1. In the Basic Wireless Settings, configure Wireless Mode to “WDS”.

Basic Wireless Settings

You could configure the minimum number of Wireless settings for communication, such as Network Name (SSID) and Channel. The Access Point can be set simply with only the minimum setting items.

Wireless Network	
Wireless On/Off	<input type="button" value="Wireless OFF"/> Current Status:Radio ON
Antenna Switch	<input type="radio"/> External <input checked="" type="radio"/> Internal
Wireless Mode	<div style="border: 1px solid red; padding: 2px;">WDS ▾</div>
Wireless Band	802.11B/G/N ▾
SSID	default <input type="text"/>
Broadcast Network Name (SSID)	<input checked="" type="radio"/> Enabled <input type="radio"/> Disabled
AP Isolation	<input type="radio"/> Enabled <input checked="" type="radio"/> Disabled
MBSSID AP Isolation	<input type="radio"/> Enabled <input checked="" type="radio"/> Disabled
BSSID	00:30:4F:19:66:38
Frequency (Channel)	AutoSelect ▾ Current Channel: 1

Figure 4-24 Wireless Mode - WDS

Step 2. Go to “Wireless Settings-> WDS”, fill in the MAC Address of the remote site.

EncrypType	Encryp Key	AP MAC Address
NONE ▾	00:30:4F:11:22:33	
NONE ▾		
NONE ▾		
NONE ▾		

Figure 4-25 WDS Configuration



1. To Setup the WDS Connection, the channel must be the same in both sites. You should fix the channel from “AutoSelect” to a static one.
2. You must fill in the MAC Address by each other. For example, enter the MAC Address of the remote site to the settings of local site; and enter the MAC Address of the local site to the settings of remote site.
3. The Encryption Type must be the same in both sites if available.

c. AP+WDS (Repeater) Mode

Repeater mode allows user to operate as a wireless repeater, extending the range for remote wireless clients and connecting them to an AP connected to the wired network. The MAC addresses of WDS peers must be configured on the Wireless 2.4G Access Point/Repeater.

Step 1. In the Basic Wireless Settings, configure Wireless Mode to “AP+WDS”.

Basic Wireless Settings

You could configure the minimum number of Wireless settings for communication, such as Network Name (SSID) and Channel. The Access Point can be set simply with only the minimum setting items.

Wireless Network	
Wireless On/Off	<input type="button" value="Wireless OFF"/> Current Status:Radio ON
Antenna Switch	<input type="radio"/> External <input checked="" type="radio"/> Internal
Wireless Mode	<div style="border: 1px solid red; padding: 2px;">AP+WDS ▼</div>
Wireless Band	802.11B/G/N ▼
SSID	default
Broadcast Network Name (SSID)	<input checked="" type="radio"/> Enabled <input type="radio"/> Disabled
AP Isolation	<input type="radio"/> Enabled <input checked="" type="radio"/> Disabled
MBSSID AP Isolation	<input type="radio"/> Enabled <input checked="" type="radio"/> Disabled
BSSID	00:30:4F:19:66:38
Frequency (Channel)	AutoSelect ▼ Current Channel: 1
HT Physical Mode	
Operating Mode	<input checked="" type="radio"/> Mixed Mode <input type="radio"/> Green Field
Channel BandWidth	<input type="radio"/> 20 <input checked="" type="radio"/> 20/40
Guard Interval	<input type="radio"/> Long <input checked="" type="radio"/> Auto
MCS	Auto ▼

Figure 4-26 Wireless Mode – AP+WDS

Step 3. Go to “Wireless Settings-> WDS”, fill in the MAC Address of the remote site.

Wireless Distribution System

Wireless Distribution System Settings

EncrypType	Encryp Key	AP MAC Address
NONE ▼	00:30:4F:11:22:33	
NONE ▼		
NONE ▼		
NONE ▼		

Figure 4-27 WDS Configuration



1. To Setup the WDS Connection, the channel must be the same in both sites. You should fix the channel from “AutoSelect” to a static one.
2. You must fill in the MAC Address by each other. For example, enter the MAC Address of the remote site to the settings of local site; and enter the MAC Address of the local site to the settings of remote site.
3. The Encryption Type must be the same in both sites if available.

4.4.5 Site Survey

This page is used to view or configure other APs near yours.

To connect with other AP by site survey, you need to configure the DA2131-V1 as “AP Client” mode in the Basic Wireless Settings page as following.

Step 1. Go to “Wireless Settings-> Basic”, select the Wireless Mode to “AP Client”,

Basic Wireless Settings

You could configure the minimum number of Wireless settings for communication, such as Network Name (SSID) and Channel. The Access Point can be set simply with only the minimum setting items.

Wireless Network	
Wireless On/Off	<input type="button" value="Wireless OFF"/> Current Status:Radio ON
Antenna Switch	<input type="radio"/> External <input checked="" type="radio"/> Internal
Wireless Mode	<input type="text" value="AP Client"/> ▼
Wireless Band	<input type="text" value="802.11B/G/N"/> ▼
SSID	<input type="text" value="default"/>
Broadcast Network Name (SSID)	<input checked="" type="radio"/> Enabled <input type="radio"/> Disabled
AP Isolation	<input type="radio"/> Enabled <input checked="" type="radio"/> Disabled
MBSSID AP Isolation	<input type="radio"/> Enabled <input checked="" type="radio"/> Disabled
BSSID	<input type="text" value="00:30:4F:19:66:38"/>
Frequency (Channel)	<input type="text" value="AutoSelect"/> ▼ Current Channel: 11

Figure 4-28 Basic Wireless Settings

Step 2. Go to “Wireless Settings->Site Survey” to scan the AP. Select the AP that you choose to connect, and then click “Next”.

Site Survey

You could configure AP Client parameters here.

	SSID	BSSID	RSSI	Channel	Authentication	Wireless Mode
<input type="radio"/>	ADN-4100	00:30:4f:2a:f0:bf	20%	1	NONE	11b/g/n
<input checked="" type="radio"/>	test	00:30:4f:21:d4:37	100%	1	WPA2PSK/AES	11b/g/n
<input type="radio"/>	FRT40xN	00:30:4f:84:23:00	70%	5	NONE	11b/g/n
<input type="radio"/>	FRT-420SN	00:30:4f:81:96:b1	39%	6	NONE	11b/g/n

Figure 4-29 Site Survey - 1

The page includes the following fields:

Object	Description
SSID	It shows the SSID of AP.
BSSID	It shows BSSID of AP.
RSSI	It shows the signal strength of current AP.
Channel	It show the current channel of AP occupied.
Encrypt	It shows the encryption status.
Wireless Mode	It show the wireless mode of AP.

Step 3. If the AP has encryption setting, it will pop out a window for you filling the encryption setting. Please fill up the code, in this case, the code was “1234567890”, and click “Apply” to connect with the AP.

Site Survey

You could configure AP Client parameters here.

AP Client Parameters	
SSID	test
MAC Address (Optional)	00:30:4f:21:d4:37
Frequency (Channel)	2412MHz (Channel 1) <input type="button" value="v"/> Current Channel: 1
Security Mode	WPA2PSK <input type="button" value="v"/>
Encryption Type	AES <input type="button" value="v"/>
Pass Phrase	1234567890
LAN Interface Setup	
DHCP Type	Disable <input type="button" value="v"/>
IP Address	10.10.10.254

Figure 4-30 Site Survey - 2

Step 4. After connected with AP, you can open “Status” page under Administrator to check link status.

The screenshot shows the web interface for a Legrand 802.11 Outdoor Wireless Access Point (DA2131). The left sidebar contains a navigation menu with the following items: Site Contents, Setup Wizard, Operation Mode, Internet Settings, Wireless Settings, Administration, Management, QoS, Upload Firmware, Settings Management, Status (highlighted), and System Log. The main content area is titled "Access Point Status" and includes a brief description: "This page show the current status and some basic settings of the device." Below this, there are three tables of information:

System information	
Firmware Version	1.0.0 Jun 21 2012
System Up Time	0 days, 0 hours, 28 mins, 20 secs
Operation Mode	Bridge Mode

Wireless information	
Status	Radio ON
Mode	AP
SSID	Legrand WiFi
Channel	6
Encryption	WPA2PSK
BSSID	00:30:4F:93:C1:54

LAN information	
DHCP Server	Disabled
LAN IP Address	192.168.40.252
Subnet Mask	255.255.255.0
MAC Address	00:30:4F:93:C1:54

Figure 4-31 AP Status

4.4.6 WPS

This section will guide you to add a new wireless device quickly to an existing network by **WPS (Wi-Fi Protected Setup)** function.

Step 1. Choose menu “**WPS**”, you will see the next screen.

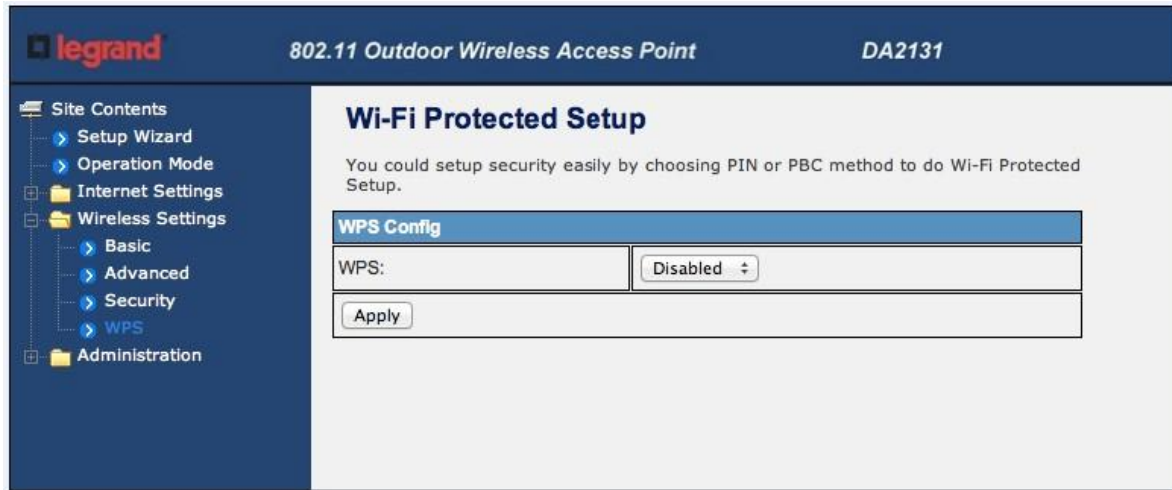

Figure 4-32 WPS Setup

The page includes the following fields:

Object	Description
WPS	Select Enable or Disable the Wi-Fi Protected Setup function. Then click <i>Apply</i> button to take effect function after change.

Step 2. To add a new device:

If the wireless adapter supports Wi-Fi Protected Setup (WPS), you can establish a wireless connection between wireless adapter and Router using either Push Button Configuration (PBC) method or PIN method.



To build a successful connection by WPS, you should also do the corresponding configuration of the new device for WPS function meanwhile.

I. By Push Button Configuration (PBC)

If the wireless adapter supports Wi-Fi Protected Setup and the Push Button Configuration (PBC) method, you can add it to the network by PBC with the following two methods.

Step 1: Choose PBC, and click “Apply”.



Figure 4-33 WPS - PBC

Step 2: Press and hold the WPS Button equipped on the adapter directly for 2 or 3 seconds. Or you can click the WPS button with the same function in the configuration utility of the adapter.



-
- 1) Step 1 & 2 should process within two minutes.
 - 2) DA2131-V1 only supports PBC method.
-

Step 3: Wait for a while until the connection established to complete the WPS configuration.

4.5 Firewall

4.5.1 MAC /IP /Port Filtering

MAC/IP/Port Filtering Settings

You may setup firewall rules to protect your network from virus,worm and malicious activity on the Internet.

Basic Settings

MAC/IP/Port Filtering Disable ▾

MAC/IP/Port Filter Settings

Source MAC address	<input style="width: 95%;" type="text"/>
Dest IP Address	<input style="width: 95%;" type="text"/>
Source IP Address	<input style="width: 95%;" type="text"/>
Protocol	None ▾
Dest Port Range	<input style="width: 45%;" type="text"/> - <input style="width: 45%;" type="text"/>
Source Port Range	<input style="width: 45%;" type="text"/> - <input style="width: 45%;" type="text"/>

Figure 4-37 MAC/IP/Port filtering

The page includes the following fields:

Object	Description
MAC/IP/Port Filtering	Select Enable or Disable the MAC/IP/Port Filtering function.
Source MAC address	Fill in the MAC address of source NIC, to restrict data transmission.
Dest IP Address	Fill in the IP address of destination, to restrict data transmission.
Source IP Address	Fill in the IP address of source, to restrict data transmission.
Protocol	Select the protocol that you want to restrict. There are four options: None, TCP, UDP and ICMP.
Dest Port Range	Fill in the start-port and end-port number of destination, to restrict data transmission.
Source Port Range	Fill in the start-port and end-port number of source, to restrict data transmission.

Action	Select Accept or Drop to specify the action of filtering policies.
Comment	Make a comment for the filtering policy.
Delete Selected	Click Delete Selected button to delete all that you selected.
Reset	Click Reset button to clear selected items.

4.5.2 Port Forwarding

Virtual Server Settings

You may setup Virtual Servers to provide services on Internet.

Port Forwarding

Port Forwarding	Disable ▾
IP Address	<input type="text"/>
Port Range	<input type="text"/> - <input type="text"/>
Protocol	TCP&UDP ▾
Comment	<input type="text"/>

(The maximum rule count is 32.)

Current Port Forwarding in system:

No.	IP Address	Port Range	Protocol	Comment

Figure 4-38 Port Forwarding

The page includes the following fields:

Object	Description
Port Forwarding	Select Enable or Disable the Port Forwarding function.
IP Address	To forward data packets coming from WAN to a specific IP address that hosted in local network behind the NAT firewall, fill in the IP address.
Port Range	To forward data packets coming from WAN to a specific IP address

	that hosted in local network behind the NAT firewall, fill in the port range.
Protocol	Specify protocol, TCP&UDP, TCP or UDP.
Comment	Make a comment for the port forwarding policy.
Delete Selected	Click Delete Selected button to delete all that you selected.
Reset	Click Reset button to clear selected items.
Virtual Server	Select Enable or Disable the Virtual Server function.
IP Address	To forward data packets coming from WAN to a specific IP address that hosted in local network behind the NAT firewall, fill in the IP address.
Public Port	To forward data packets coming from WAN to a specific IP address that hosted in local network behind the NAT firewall, fill in the public port.
Private Port	To forward data packets coming from WAN to a specific IP address that hosted in local network behind the NAT firewall, fill in the private port.
Protocol	Specify protocol, TCP&UDP, TCP or UDP.
Comment	Make a comment for the virtual server policy.
Delete Selected	Click Delete Selected button to delete all that you selected.
Reset	Click Reset button to clear selected items.

4.5.3 DMZ

DMZ Settings

You may setup a De-militarized Zone(DMZ) to separate internal network and Internet.

DMZ Settings	
DMZ Settings	Disable ▾
DMZ IP Address	<input type="text"/>

Figure 4-39 DMZ

The page includes the following fields:

Object	Description
DMZ Settings	Enable or Disable the DMZ function.
DMZ IP Address	To support DMZ in your firewall design, fill in the IP address of DMZ host that can be access from the WAN interface.

4.5.4 System Security

System Security Settings

You may configure the system firewall to protect AP/Router itself from attacking.

Remote management

Remote management (via WAN)
Deny ▾

Ping form WAN Filter

Ping form WAN Filter
Disable ▾

Stateful Packet Inspection (SPI)

SPI Firewall
Disable ▾

Apply
Reset

Figure 5-40 System Security

The page includes the following fields:

Object	Description
Remote management	Select Deny or Allow for remote management function.
Ping form WAN Filter	Select Disable or Enable for Ping permit from WAN.
SPI Firewall	Select Disable or Enable for SPI firewall function.

4.5.5 Content Filtering

Content Filter Settings

You can setup Content Filter to restrict the improper content access.

Webs Host Filter Settings

Add a Host(keyword) Filter:

Keyword	<input style="width: 95%;" type="text"/>
---------	--

Current Website Host Filters:

No	Host(Keyword)
----	---------------

Webs URL Filter Settings

Add a URL filter:

URL:	<input style="width: 95%;" type="text"/>
------	--

Figure 4-41 Content Filtering

The page includes the following fields:

Object	Description
Keyword	Fill in a word for Webs Host Filter policy.
URL	Fill in a URL string for URL filter. Then click Add button to save the URL filter policy or click Reset button to clear the field.
Delete	Click Delete button to delete all that you selected.
Reset	Click Reset button to clear selected items.

4.6 Administrator

4.6.1 Management

legrand 802.11 Outdoor Wireless Access Point DA2131

System Management

You may configure administrator account and password, NTP settings, and Dynamic DNS settings here.

Language Settings

Select Language:

Administrator Settings

Username: Password:

NTP Settings

Current Time: Sat Jan 1 00:01:20 UTC 2 Time Zone: (GMT-05:00) Eastern Time

NTP Server: NTP synchronization(hours):

DDNS Settings

Dynamic DNS Provider: None

Account: Password: DDNS:

Figure 4-42 System Management

The page includes the following fields:

Object	Description
Username	Fill in the user name for web management login control.
Password	Fill in the password for web management login control.
Current Time	It shows the current time.
Time Zone	Select the time zone in your country from pull-down menu..
NTP Server	Fill in NTP server IP address.
NTP synchronization	Fill in a number to decide the synchronization frequency with NTP server.
Dynamic DNS Provider	Click the drop down menu to pick up the right DDNS provider you registered.
Account	Fill in the account of DDNS you registered.
Password	Fill in the password of DDNS you registered.
DDNS	Fill in the domain name that you registered.

4.6.2 Upload Firmware



Figure 4-43 Upload F/W

The page includes the following fields:

Object	Description
Location	Click the Browse button to select the new firmware image file on PC. And click the Apply button to upgrade firmware.

4.6.3 Settings Management



Figure 4-44 Setting Management

The page includes the following fields:

Object	Description
Export Button	Click Export button to export the current configuration to your PC.
Settings file location	Click Browse button to select the configuration file from your PC, then click Import button to update the configuration.
Load Default Button	Click the Load Default button to reset the configuration parameter to factory defaults.

4.6.4 Status

This page shows the current status and some basic settings of the device, includes system info, Internet Configurations and Local Network.

The screenshot shows the web interface for a Legrand 802.11 Outdoor Wireless Access Point (DA2131). The left sidebar contains a navigation menu with the following items: Site Contents, Setup Wizard, Operation Mode, Internet Settings, Wireless Settings, Administration, Management, QoS, Upload Firmware, Settings Management, Status, and System Log. The main content area is titled "Access Point Status" and includes a brief description: "This page show the current status and some basic settings of the device." Below this, there are three tables of information:

System Information	
Firmware Version	1.0.0 Jun 21 2012
System Up Time	0 days, 0 hours, 28 mins, 20 secs
Operation Mode	Bridge Mode

Wireless Information	
Status	Radio ON
Mode	AP
SSID	Legrand WiFi
Channel	6
Encryption	WPA2PSK
BSSID	00:30:4F:93:C1:54

LAN Information	
DHCP Server	Disabled
LAN IP Address	192.168.40.252
Subnet Mask	255.255.255.0
MAC Address	00:30:4F:93:C1:54

Figure 4-45 Status

4.6.5 System Log

This page is used to view the system logs.

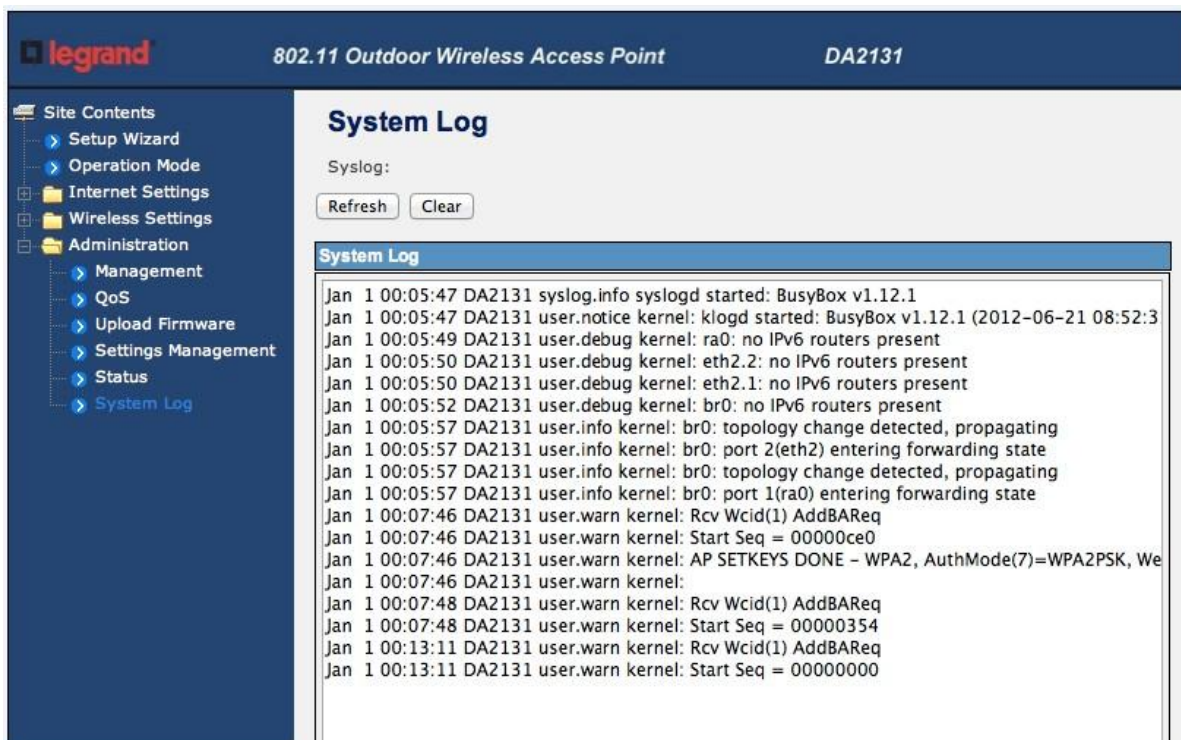

Figure 4-46 System Log

The page includes the following fields:

Object	Description
Refresh	Click the Refresh button to refresh the log shown on the screen.
Clear	Click the Clear button to clear the log display screen.

Appendix A: Specifications

Product	DA2131-V1 150Mbps 802.11n Wireless Outdoor Access Point
Hardware Specification	
Standard support	IEEE802.11b/g IEEE 802.11n IEEE 802.3 10Base-T IEEE 802.3u 100Base-TX IEEE 802.3x Flow Control
Chipset	Ralink RT3050
Memory	16 Mbytes DDR SDRAM 4 Mbytes Flash
Interface	Wireless IEEE802.11b/g/n LAN: 1 x 10/100Base-TX, Auto-MDI/MDIX WAN: 1 x 10/100Base-TX, Auto-MDI/MDIX
Antenna	Internal (Default): 12dBi directional antenna (Vertical-Pol) <ul style="list-style-type: none"> ■ Horizontal: 60 degree ■ Vertical: 30 degree External (Option): RP-SMA type Connector <ul style="list-style-type: none"> ■ Switchable by Software ■ For External Antenna Mode, attach antenna before power on
Enclosure	IP55 waterproof case
PoE	Passive PoE / 12V DC LAN RJ-45 Pin Assignment: PIN 4, 5(+), PIN 7, 8(-)
Wireless Interface Specification	
Frequency Band	2.4~2.4835GHz
Modulation	Transmission/Emission Type: DSSS / OFDM Data modulation type: OFDM with BPSK, QPSK, 16-QAM, 64-QAM, DBPSK, DQPSK, CCK
Data Rate	802.11b: 11, 5.5, 2 and 1 Mbps with auto-rate fall back 802.11g: 54, 48, 36, 24, 18, 12, 9 and 6Mbps 802.11n (20MHz): up to 72Mbps 802.11n (40MHz): up to 150Mbps
Opt. Channel	America/ FCC: 2.414~2.462GHz (11 Channels) Europe/ ETSI: 2.412~2.472GHz (13 Channels) Japan/ TELEC: 2.412~2.484GHz (14 Channels)
RF Output Power	802.11b: 27 ± 1dBm 802.11g: 26 ± 1dBm 802.11n: 22 ± 1dBm
Receiver Sensitivity	IEEE 802.11b: -93dBm IEEE 802.11g: -91dBm IEEE 802.11n: -812dBm
Media Access Control	CSMA/CA
Output Power Control	Range 1~100, default:100
Power Requirements	12V DC, 1A (switching)
Wireless Management Features	
Wireless Mode	<ul style="list-style-type: none"> ■ AP ■ Client

	<ul style="list-style-type: none"> ■ WDS PtP ■ WDS PtMP ■ WDS Repeater (AP+WDS) ■ Universal Repeater (AP+Client)
Channel Width	20MHz / 40MHz
Encryption Security	64/128-bits WEP WPA, WPA-PSK WPA2, WPA2-PSK 802.1X
Wireless Isolation	Enable it to isolate each connected wireless clients, to let them cannot access mutually.
Wireless Security	Provide wireless LAN ACL (Access Control List) filtering
	Wireless MAC address filtering
	Support WPS (WIFI Protected Setup)
	Enable/Disable SSID Broadcast
B/G Protection Mode	A protection mechanism prevents collisions among 802.11b/g modes
Max. Wireless Client	25
Max. WDS AP	4
Software	
LAN	Built-in DHCP server supporting static IP address distributing
	Support UPnP
	Support IGMP Proxy, DNS Proxy
	Support 802.1d STP - Spanning Tree Protocol
WAN Protocol	<ul style="list-style-type: none"> ■ Static IP ■ DHCP (Dynamic IP) ■ PPPoE ■ PPTP ■ L2TP
VPN Passthrough	<ul style="list-style-type: none"> ■ PPTP ■ L2TP ■ IPsec
Operating Mode	<ul style="list-style-type: none"> ■ Bridge ■ Gateway ■ Ethernet Converter (WISP)
Firewall	NAT firewall with SPI (Stateful Packet Inspection)
	Built-in NAT server supporting Port Forwarding (Virtual Server), and DMZ
	Built-in firewall with Port/ IP address/ MAC/ URL filtering
Max. Wired Client	60
NTP	Network Time Management
Management	Web UI, DHCP Client, Configuration Backup & Restore, Dynamic DNS
Diagnostic tool	System Log
Environment & Certification	
Operation Temp.	Temp.: -20~70°C, Humidity: 10%~95% non-condensing
Storage Temp.	Temp.: -30~80°C, Humidity: 5%~95% non-condensing
IP Level	IP65
Regulatory	CE / FCC / RoHS