

The Distracted Driving Device (DDD) system is comprised of two separate devices, the DDD Communication Device (PTE-5) and the DDD Handset Dock (DDD-1). Both devices will need to be installed in the vehicle as shown in this document.

## WIRING DIAGRAM

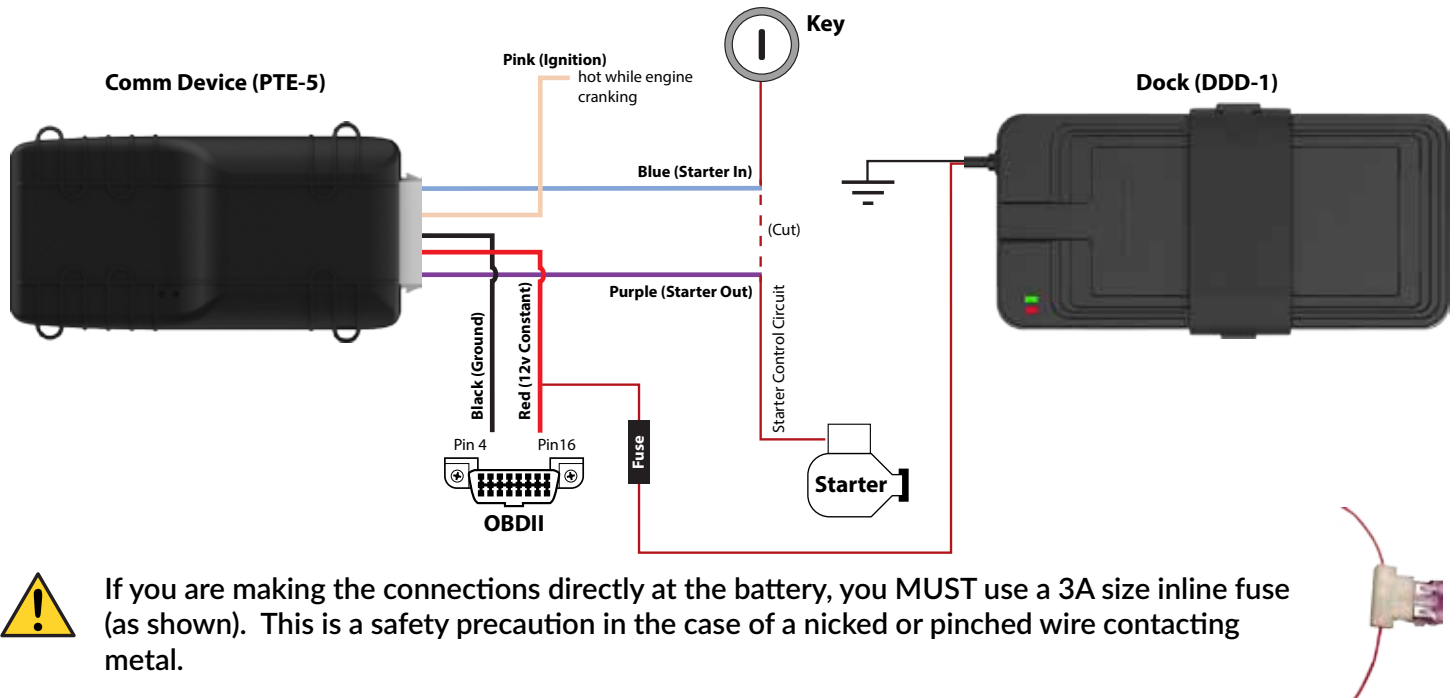

If you are making the connections directly at the battery, you **MUST** use a 3A size inline fuse (as shown). This is a safety precaution in the case of a nicked or pinched wire contacting metal.



## STEP 1: INSTALL COMM DEVICE

### POTENTIAL INSTALLATION LOCATIONS

The Comm Device (PTE-5) should be installed as high in the dash as possible to ensure the best performance and to help prevent tampering.

- Above or behind instrument cluster
- Above any accessible air vents
- Above or behind the radio



**Note:** When mounting the device, the LED's must be facing up and the device should not be obstructed by metal.

# DEVICE HARNESS ELECTRICAL CONNECTIONS

**NOTE:** For all connections, soldering is recommended. Posi-tap and butt connectors are also acceptable (as shown).

**GROUND** - Attach to a secured bare metal chassis ground location such as to a new or existing threaded fastener, or to a grounded circuit such as Pin 4 of the OBDII connector (as shown).

**12v CONSTANT** - Any 12v constant source, that is not being monitored by the computer for voltage draw, can be used, like Pin 16 of the OBDII connector (as shown). Use inline fuse if going direct to the battery.



**NOTE:** In late model vehicles, starter and ignition connections should be made under hood, near main fuse relay. If harness wires are not long enough, use 3-in-1 wire or equivalent to extend harness (as shown).

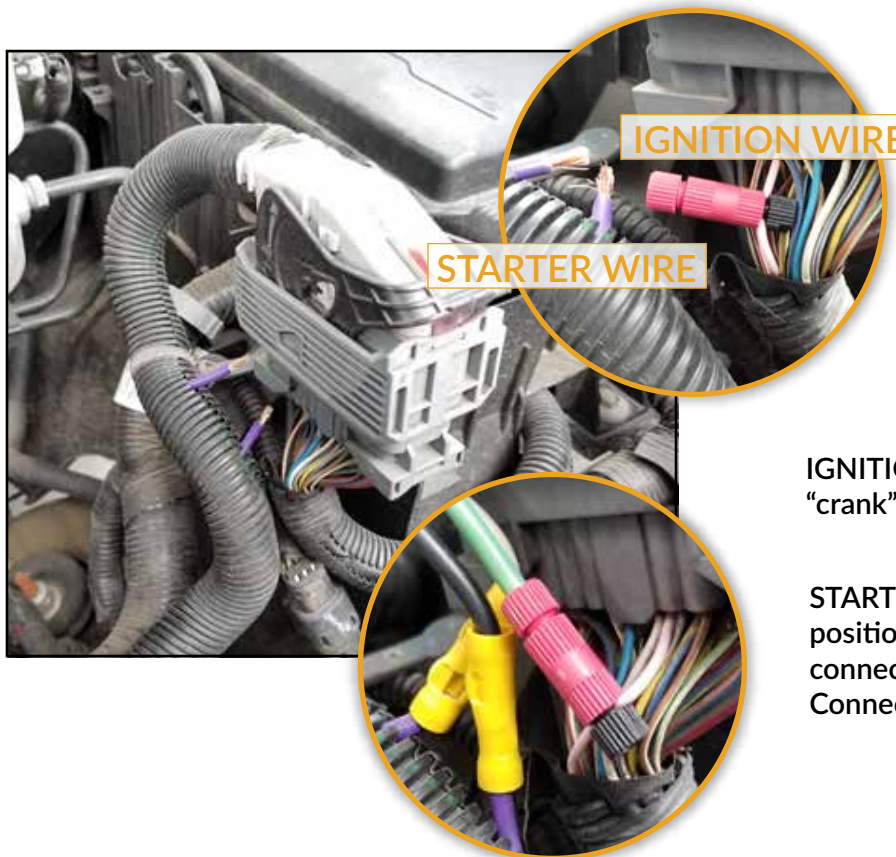

**NOTE:** When making these connections, use grommets if wires must penetrate the firewall and use adequate looming if placing wires in the engine compartment to protect from hot metal surfaces and corrosive liquids.

**IGNITION WIRE**- a wire with 12V in “key on” and “crank” positions.

**STARTER WIRE** - the wire with 12V in “crank” position only. Once the starter wire is cut, connect Harness blue wire to key side of starter. Connect Harness purple wire to solenoid side.

## STEP 2: INSTALL DOCK

Install Dock in glove compartment (as shown). Make small hole near Dock location for Ground & 12V Constant wires to pass through. Zip-tie wires underneath glove compartment to secure Dock and prevent removal from mounted location.

Note: Please ensure Dock location and placement will allow unrestricted access by the user to insert their handset into the Dock and easily secure it using the rubber strap.



Dock Ground Wire- Bare metal or a common ground connection is recommended on the passenger side of vehicle (as shown).



Dock 12V Constant Wire- Connect Dock 12V Constant to inline fuse (size 3A). Then connect inline fuse to Harness 12V Constant connection as made previously at OBDII connector.

## STEP 3: ACCOUNT SETUP

### A) Download the App

Use of the Distracted Driving Device requires the installation of the Distracted Driving Device Application on the user's handsets (smart phones). The Application can be quickly located by scanning the following QR Code.



### B) Find the labels

During the setup of the Application, the user will need to enter the serial numbers of the Comm Device (PTE-5) and the Dock (DDD-1). These serial numbers can be located on the bottom of the devices as well as on the outside of the box as shown below.

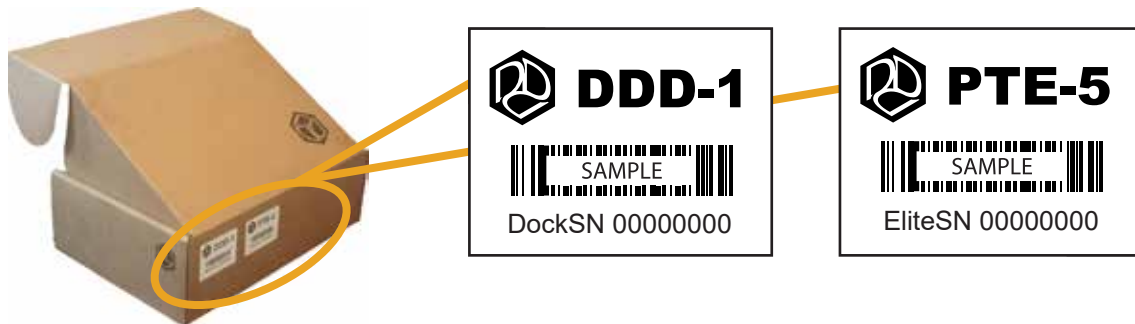

### C) Scan the barcodes

Following the in-App instructions, scan the barcode (or manually enter serial number) for each device.

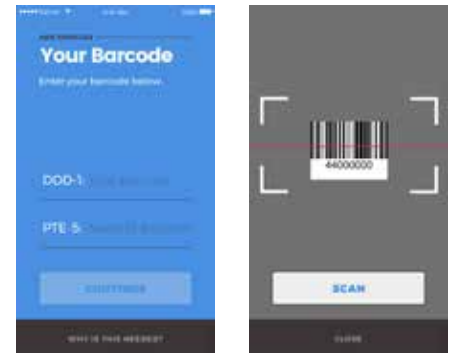

### D) Complete Account Setup

Follow the instructions in the App to complete the device pairing and account setup.

#### EMERGENCY OVERRIDE:

The Emergency Override is failsafe to be used in the event the required phone has been lost, has a dead battery or is otherwise malfunctioning. When the Emergency Override is used to start the vehicle, a message will be sent to the vehicle owner advising of its use. The DDD system may be bypassed by turning the key to the ignition position and then off 5 times in succession. The vehicle will then be permitted to start without a docked handset.

**Need Help?**

**Visit: [DistractedDrivingDevice.com](http://DistractedDrivingDevice.com) or Call 1-800-579-9077**