

User's Manual

PAXAR

9840CL Printer

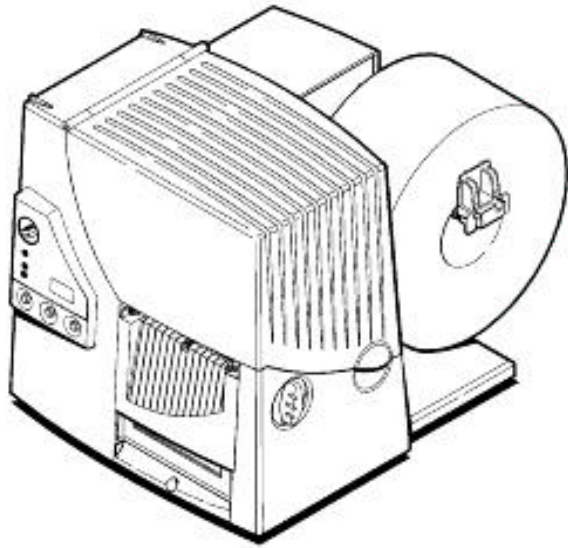

PAXAR Systems Group

**Manual Edition 1.1
15 December 2000**

Manual Part Number 441397

This page left blank intentionally.

Contents

Getting Started - 1	1
Audience.....	2
Unpacking the Printer.....	2
Connecting the Power Cable.....	2
Establishing Communications.....	3
Connecting the Communication Cable	3
Default Serial Port Communication Values	3
Default Printer Settings	4
Using the Control Panel.....	4
Printer Status Lights	4
Button Functions	5
Status Code Box	5
Setting Dip Switches	6
DIP Switches.....	7
Loading Supplies - 2	9
Loading Labels.....	10
Loading Ribbon	15
Adjusting the Wide/Narrow Knobs	19
Printing - 3	21
Printing.....	21
Printing an Error Label	21
Non-Printing Zone	22
Preventing Jams.....	22
Printing Serial Bar Codes	23
Adjusting Print Positions.....	23
Adjusting the cut angle.....	24
Using the Knife.....	25
Care and Maintenance - 4	28
Clearing Supply Jams.....	29
Clearing a Knife Jam.....	29
Cleaning	30
Replacing the Printhead.....	32
Adjusting the Print Contrast	36
Replacing the Fuse	37
Lubricating the Knife	38
Troubleshooting - 5	39
Printing a Test Label	40
Troubleshooting	41

Error Messages.....	42
Data Errors.....	42
Communication Failures.....	47
Data Formatting Errors.....	48
Machine Faults.....	49
Specifications & Accessories - A	51
Printer.....	51
Supply Specifications.....	52
Ribbon Specifications.....	53
Accessories.....	54
Contacting Paxar	55

Getting Started - 1

The Paxar 9840CL Care Label printer lets you print text, graphics, and bar codes on thermal transfer (ribbon) fabric labels.

This chapter includes information about

- ◆ unpacking the printer.
- ◆ connecting the power cord.
- ◆ connecting the communications cable.
- ◆ using the printer's control panel.

Audience

The Operator's Handbook is for the person who prints and applies labels.

Unpacking the Printer

After you unpack the printer, you should have: a 9840CL printer, power cord, communication cable and a ribbon take-up core (may already be on take-up reel).

Keep the box and packaging material in case the printer ever needs repair.

Power cords are not supplied with 230-volt printers. You need to purchase a power cord separately. The power cord requires IEC 320 STD C13 end finish for the printer interface and it must meet requirements for 1.6 Amps at 115VAC and 1 Amp at 230VAC.

Connecting the Power Cable

To connect the power cable:

1. Plug the power cable into the socket. Plug the other end of the cable into a grounded electrical outlet.
2. Turn on the printer. Press (I) to turn on and (O) to turn off the printer.

For information about replacing the fuse, see Chapter 4, "Care and Maintenance."

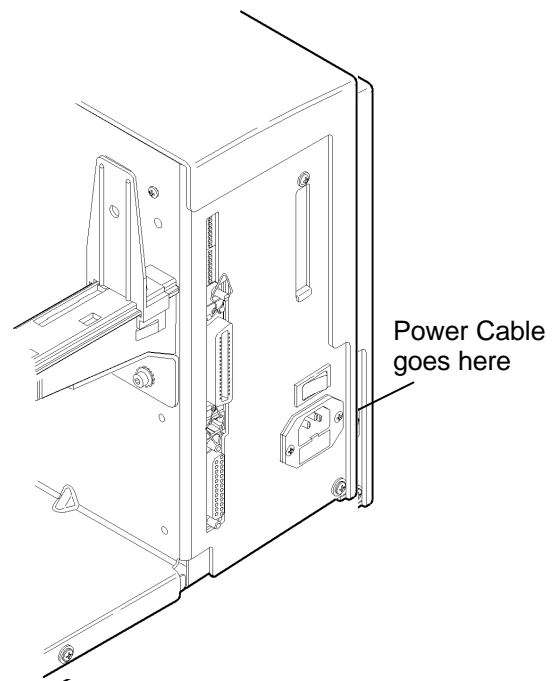

Establishing Communications

Before the printer can accept print jobs from the host, you must:

- ◆ Connect the communication cable to the printer and to the host.
- ◆ Set the communication values on the printer to match those at the host. (Only required if you are using the serial port.)

Connecting the Communication Cable

Make sure the printer is off before connecting the cable to the communication port. Ask your System Administrator which method to use to communicate with the host:

- ◆ Serial Communication
 - 9 to 25 pin cable
 - 25 to 25 pin cable
- ◆ Parallel Communication
 - IEEE-1284 or Centronics mode cable

See "Setting DIP Switches," for more information.

Connect the communications cable to the appropriate port on your computer. If you are unsure where to connect the cable, consult your computer documentation.

Note: It is highly recommended that you use the cable supplied with your printer. Paxar cannot be responsible for communications problems when a non-Paxar cable is used.

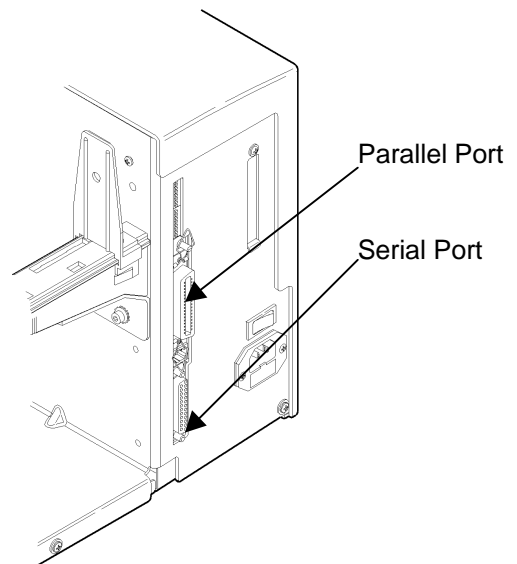

Connect the other end of the communication cable into the appropriate port on the printer. Secure the cable with the connecting screws (serial) or spring clips (parallel).

Default Serial Port Communication Values

If you are communicating with the host through the serial port, make sure the printer's communication values match those at the host. The factory default values are: 9600 Baud, 8 bit data frame Word Length, 1 Stop Bit, no Parity, and XON/XOFF Flow Control.

To change the printer's communication values, ask your System Administrator or see "Setting DIP Switches" to change the DIP switch settings.

Default Printer Settings

These defaults can be changed using Paxar's PCMate software. Print Speed - 4.0 ips (inches per second), Ribbon - High Energy, Supply Type - Black Mark, Contrast - 255, Backfeed - Enabled, Dispense Position - 120 dots, Backfeed Distance - 110 dots.

Using the Control Panel

The control panel helps you check printer status, displays error codes, and allows you to perform some basic printer functions.

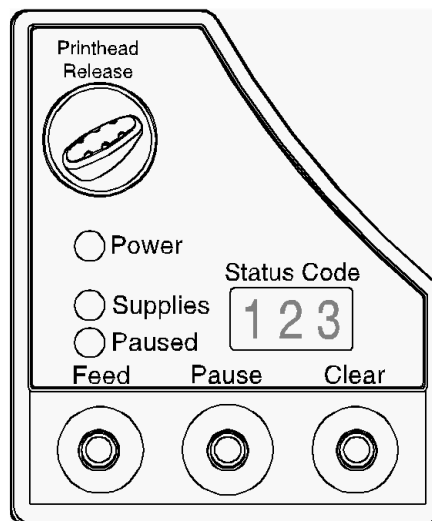

Printer Status Lights

- Power:** The printer shows a steady green light when it is on.
- Supplies:** The printer shows a blinking amber light when it is out of labels or ribbon, or when you have a supply jam.
- Paused:** The printer shows a steady amber light when paused.
- The printer shows a blinking amber light when there is a data, communication, or data formatting error. See the status code box for the error code. The printer also shows

a blinking amber light when it's ready to print a label in the On-Demand mode. See Chapter 3, "Printing" for more information.

Button Functions

- Feed:** Prints a label in the On-Demand mode. Feeds a blank label if there is no print job.
- Prints a label with error information that is useful to your System Administrator if an error is displayed.
- Pause:** Pauses the current print job or resumes a paused print job. When the Paused light is on, the job is paused.
- Feed and Pause:** Prints a test label when you press the buttons at the same time.
- Feed and Clear:** Allows you to adjust print positions from paused mode. See Chapter 3, "Printing" for more information.
- Clear:** Clears an error.
Cancels the current print job.
- Cancels all queued print jobs if pressed for two seconds. Also clears the communication queue and cancels any packet being received.

To cancel a single or all queued print jobs, the printer must be in paused mode before Clear is pressed.

Status Code Box

The status code box displays a three-digit error code to identify any problem the printer may have. For a description of the problem, look up the error code in Chapter 5, "Troubleshooting."

If there is no error, the display will be blank.

Setting Dip Switches

To change the DIP switch settings, move the switches to the desired position and then turn on the printer. If you select Software Controlled, the parameters in Packet F will override the communication settings. Software Controlled uses the last sent Packet F settings or the defaults. Turning on the printer activates the DIP switch settings. Make sure the DIP switch settings match the printer's setup for ribbon or supply type.

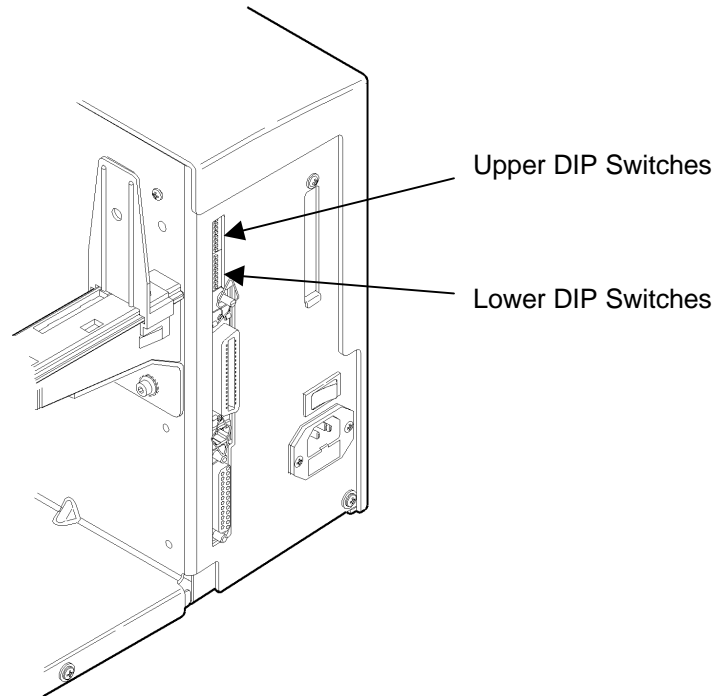

DIP Switches

Upper DIP Switches

	1	2	3	4	5	6	7	8
Baud Rate								
38400	ON	ON	OFF					
19200	ON	OFF	ON					
9600	ON	OFF	OFF					
4800	OFF	ON	ON					
2400	OFF	ON	OFF					
1200	OFF	OFF	ON					
Software Control	OFF	OFF	OFF					
Data Bits								
7 Data Bits				ON				
8 Data Bits				OFF				
Stop Bits								
2 Stop Bits					ON			
1 Stop Bit					OFF			
Parity								
Even						ON	OFF	
Odd						OFF	ON	
None						OFF	OFF	
Parallel Port								
Centronics Mode								OFF
IEEE-1284								ON

Values in bold indicate the default setting (9600 Baud; 8 Data Bits; 1 Stop Bit; No Parity; and Centronics Mode).

Communication settings at the printer must match those at the host. Make sure your host is capable of communicating at the speed you select for the printer.

Lower DIP Switches

	1	2	3	4	5	6	7	8
Flow Control XON/XOFF RTS/CTS DTR	ON OFF OFF	OFF ON OFF						
Diagnostics Normal Diagnostics Mode			OFF ON					
Verifier No Verifier Verifier Installed				OFF ON				
Supply Type Die Cut or Edge Aperture Black Mark Continuous Center Aperture					OFF OFF ON ON	OFF ON OFF ON		
Ribbon Transfer Direct,							OFF ON	
Feed Mode Disable On-Demand Enable On-Demand								OFF ON

Values in bold indicate the default setting (RTS/CTS Flow Control; Normal Mode; No Verifier; Continuous Supply; Transfer; and Continuous Mode).

Shaded DIP switches are not enabled (verifier and feed mode).

Loading Supplies - 2

This chapter describes how to load a roll of supply and a ribbon roll.

You can use Paxar's 9830CL fabric label kits containing perforated fabric labels and ribbon. If you switch from black mark to continuous supplies make sure the DIP switches are set correctly.

Make sure you use only approved Paxar supplies. See Appendix A, "Specifications and Accessories" for a list of Paxar supplies or contact your Paxar Representative for more information.

If you experience label jamming with narrow supplies in humid environments, store supplies separately from the printer in a dry, less humid environment.

CAUTION

The width of the ribbon must be greater than the supply width. Since some supplies are more abrasive to printheads than others, using a ribbon wider than your supply helps protect the printhead. Failure to do this may void your printhead warranty. Replacement printheads are expensive.

Loading Labels

Make sure the printer is configured for the correct supply type.

To load a roll of labels:

1. Open the cover.

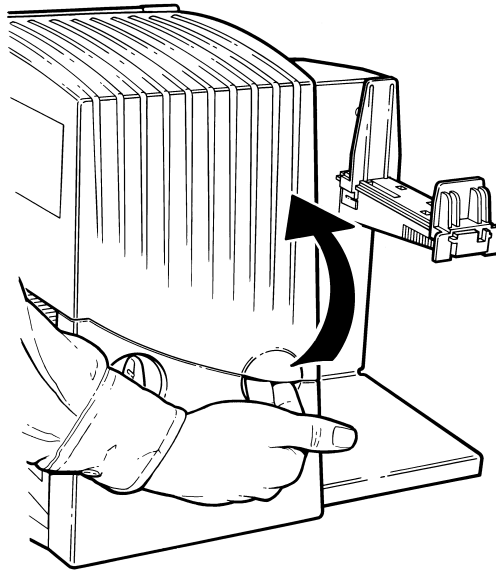

2. Unlock the printhead by turning the retaining latch.

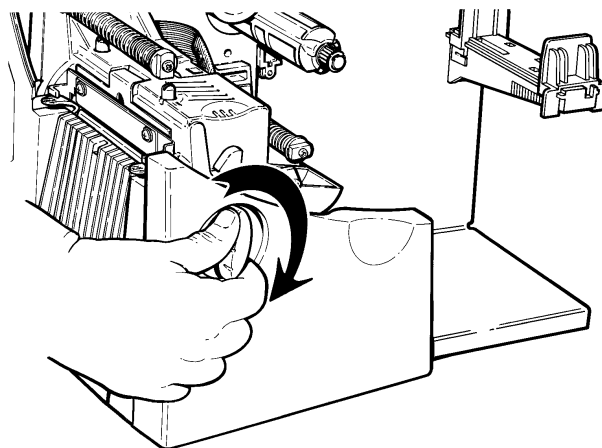

3. Lift printhead assembly using the printhead tab until the assembly locks into place.

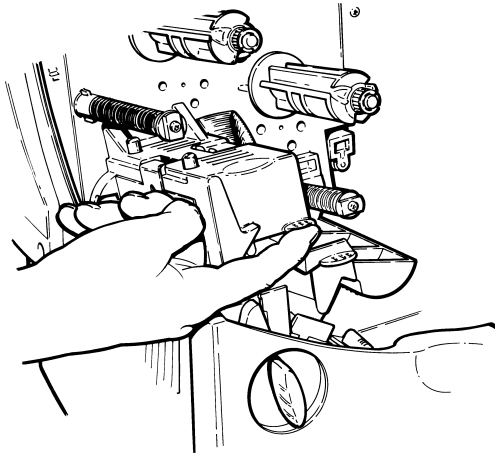

CAUTION

Make sure you use only approved Paxar supplies. See Appendix A, "Specifications and Accessories" for a list of Paxar supplies or contact your Paxar Representative for more information.

4. Place the roll of supply on the supply holder. Make sure the supply unrolls from the top as shown.

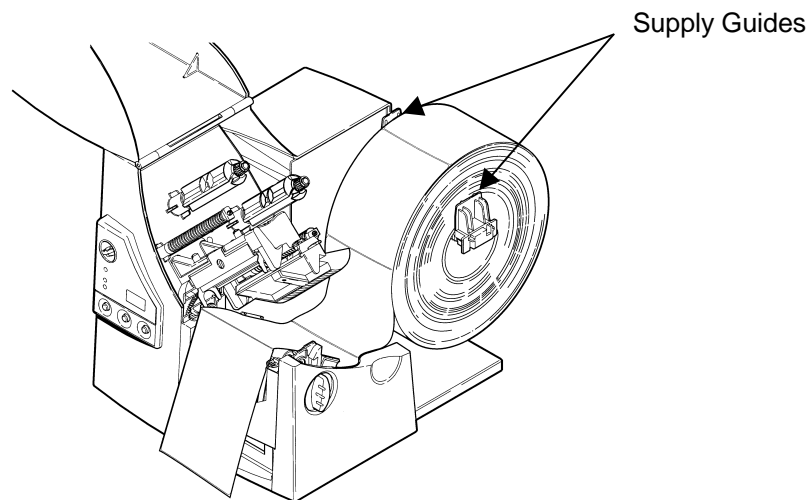

Do not pick up the printer by the supply holder.

5. Adjust the supply holder guides so the sides barely touch the roll. Make sure the supply roll turns freely.

6. Push down on the supply lever to unlock the supply guides.
7. Lay the label strip across the supply guide. Lift the auxilliary pollers slightly and thread the supply under the rollers until it appears in the knife opening.

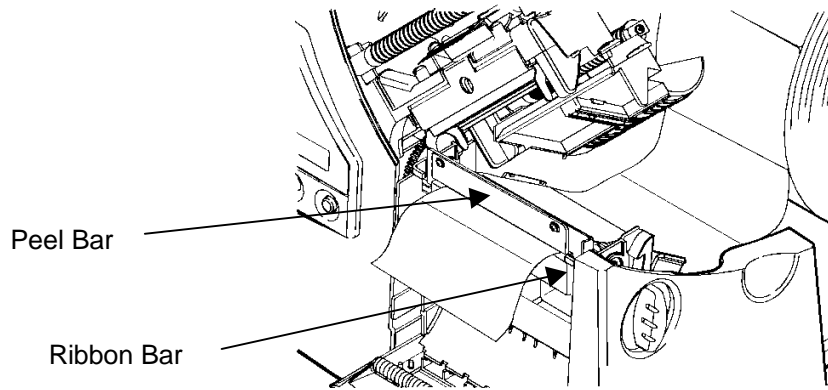

CAUTION

Make sure the supply is straight in the supply path and aligned with the printhead.

8. Tuck the supply under the nibs.

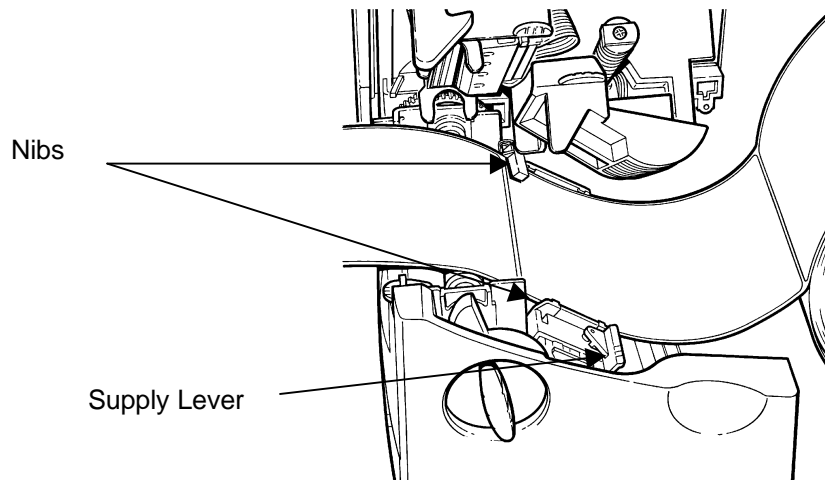

Make sure a few inches of supply are past the front end of the printer.

9. Adjust the supply guides so they touch the supply. Push up on the supply lever to lock the supply guides into place.
10. Hold the printhead assembly by the printhead tab while pressing down on the printhead release.

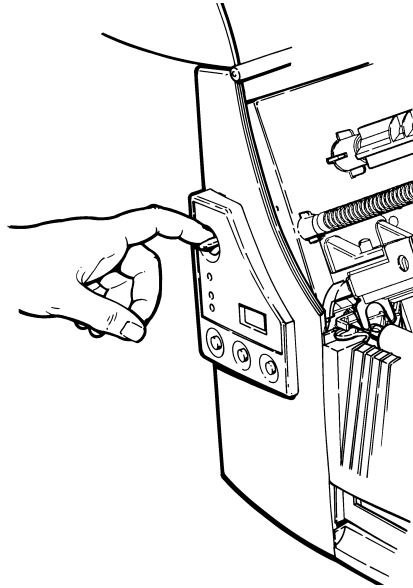

11. Close the printhead by pressing down on the thumb well until you hear it click into place.

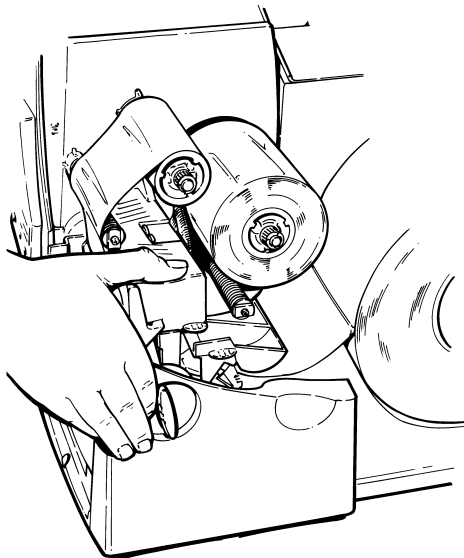

12. Close the cover.

13. Press Feed to position the supply under the printhead.

You may need to adjust the wide/narrow knobs depending on the width of your supply. See Chapter 4, "Care and Maintenance" for more information.

If the printer will be unused for extended periods of time, leave the printhead unlatched.

Loading Ribbon

To load ribbon:

1. Open the cover.
2. Unlock the printhead by turning the retaining latch.
3. Lift printhead assembly using the printhead tab until the assembly locks into place.

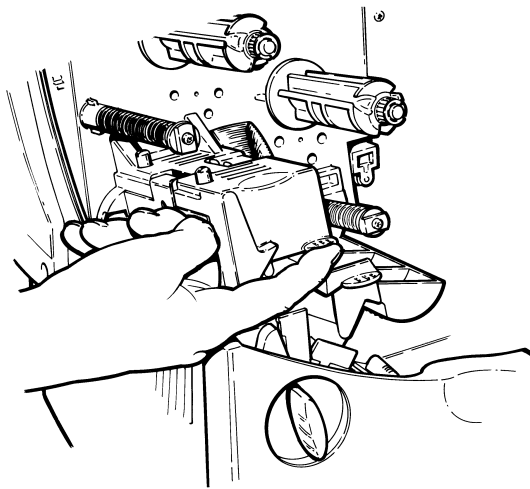

CAUTION

Make sure you use only approved Paxar supplies. See Appendix A, "Specifications and Accessories" for a list of Paxar supplies or contact your Paxar Representative for more information.

4. Push the deflector tab down.

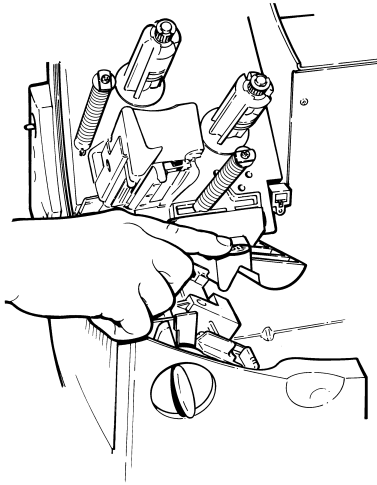

5. Slide the extra ribbon core on the take-up reel as far as it will go with the writing on the end of the core facing out. Use your empty ribbon core as the take-up core. The take-up core only fits on the take-up reel one way. (An extra take-up core is available. See "Accessories" in Appendix A for more information.)
6. Remove the new ribbon from the package as shown. Do not wrinkle or crush the new ribbon.

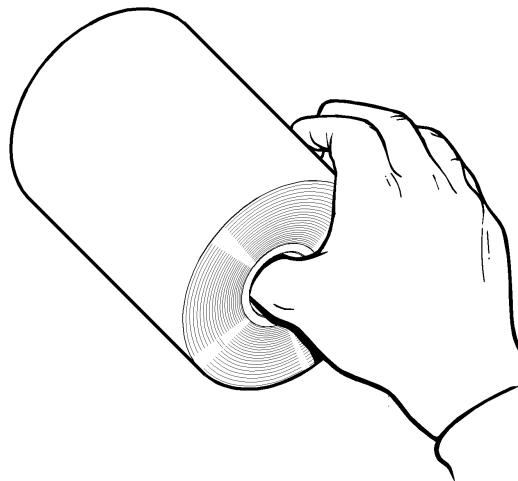

CAUTION

Since some supplies are more abrasive to printheads than others, using a ribbon wider than your supply helps protect the printhead. Failure to do this may void your printhead warranty.

- Slide the ribbon onto the back reel as far as it will go with the writing on the end of the core facing out. The ribbon roll only fits on the reel one way. Carefully unwind a few inches of ribbon from the bottom of the roll.

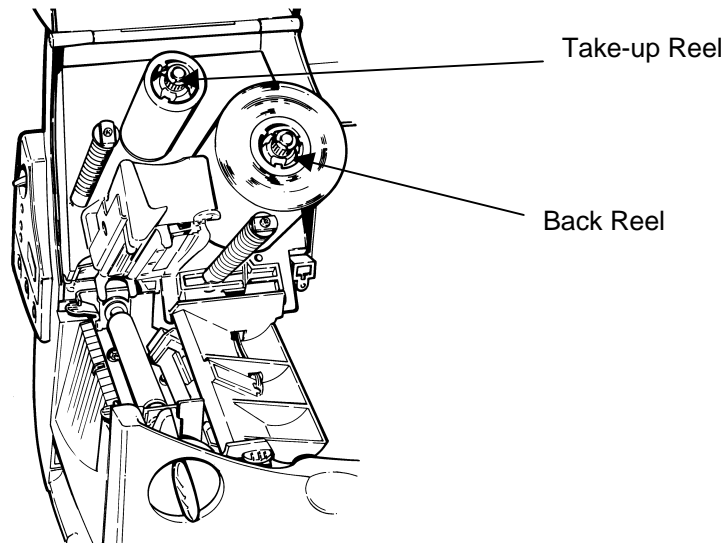

- Carefully feed the ribbon under both ribbon rollers and printhead as shown.

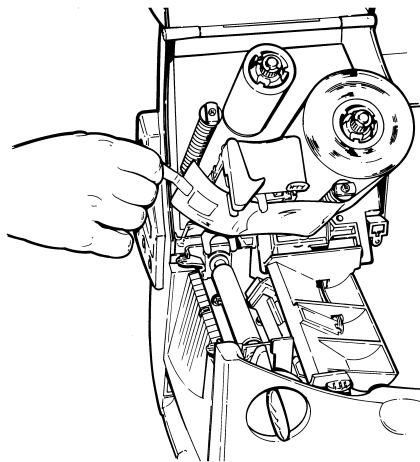

- Tape the ribbon to the take-up core. ***Do not tape the ribbon to the take-up reel.***

10. Align the ribbon with the printhead and supply.

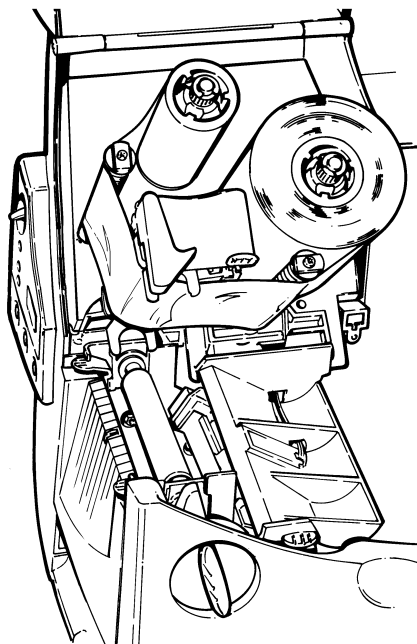

CAUTION

Make sure the ribbon is straight and centered throughout the path.

11. Rotate the take-up core until the leader is past the printhead.

12. Remove any slack in the ribbon by turning the take-up reel clockwise.

13. Hold the printhead assembly by the printhead tab while pressing down on the printhead release.

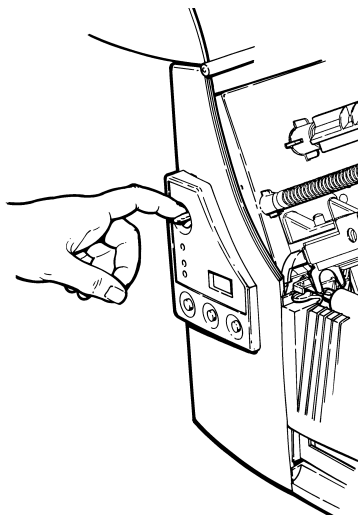

14. Close the printhead by pressing down on the thumb well until you hear it click into place. Close the cover.

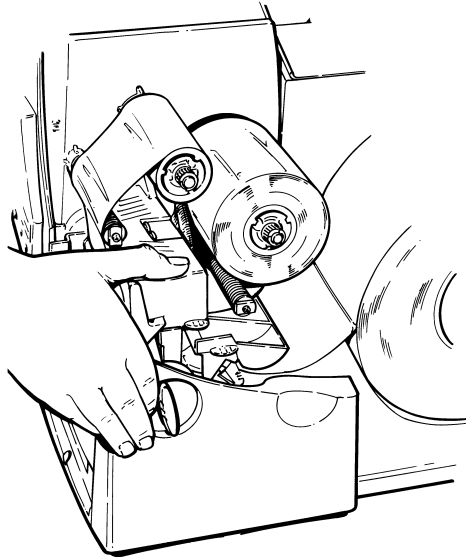

Adjusting the Wide/Narrow Knobs

You may need to adjust the two wide/narrow knobs according to the width of your supply. For supply that is more than two inches, adjust the knobs to the wide setting. For supply that is two inches or less, adjust the knobs to the narrow setting.

You must adjust both of the knobs to the same position.

If you experience ribbon smudging in cold, dry environments, adjust the wide/narrow knobs to the wide setting.

For wide supplies, push down and turn the wide/narrow knobs clockwise with a screwdriver.

For narrow supplies, turn the wide/narrow knobs counter-clockwise with a screwdriver until it pops back up.

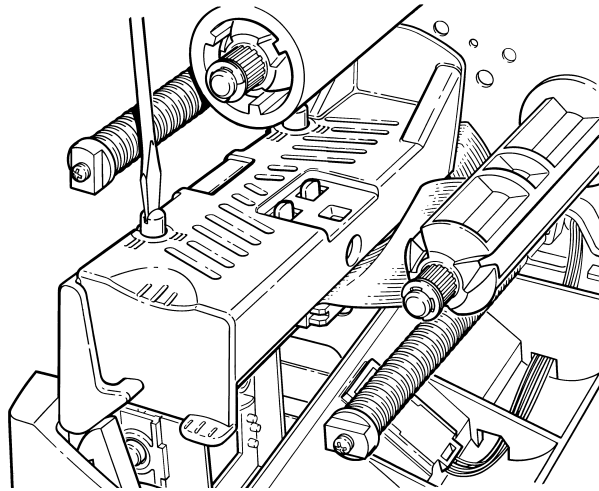

The adjustment is shown in the wide position.

Printing - 3

- ◆ This chapter explains how to
- ◆ use on-demand mode printing.
- ◆ print an error label.
- ◆ adjust the print positions.
- ◆ print care symbols and special characters, such as the Euro-Dollar symbol.

Printing

The host sends online packets containing print jobs to the printer.

To print:

1. Turn on the printer.
2. Download a format and a batch. See your System Administrator for more information about downloading packets.
3. The printer prints a strip of labels.
4. Remove the printed labels.

Printing an Error Label

PAXAR

MODEL: M9840 S/W: Version 6.4.0.0

If the printer displays a data error (errors 0 - 499), press Feed to print an error label and continue printing. See your System Administrator about the error label.

FORMAT NAME : 40200
BATCH NAME :
PACKET TYPE : F
FIELD TYPE : C
LINE # : 8
ERROR # : 18

Non-Printing Zone

A non-print zone is required for text (light copy) and bar codes (heavy copy). Thin lines and most fonts require a 0.25 inch non-print zone at the leading edge of the label. Bar codes, bold fonts, and Care symbol fonts require a 0.375 inch non-print zone at the leading edge of the label. Without these non-print zones, the ribbon sticks to the supply and can cause jams.



PCMate Software has a built-in non-print zone; however, some third party software packages may not. You should verify the non-print zone or check defaults.

Regardless of the software package you are using to create/design formats, do not place logos or bar codes too close to the edge of your supply.

Preventing Jams

To prevent jams

- ◆ design formats using the appropriate non-print zones.
- ◆ do not leave the printhead closed (in the locked position) longer than 30 minutes without printing. Open (unlock) the printhead before a break period, at the end of each shift, and at the end of each day.

Printing Serial Bar Codes

Currently, the 9830CL printer does not support printing serial (ladder) bar codes.



Parallel (Picket Fence) Bar Code



Serial (Ladder) Bar Code

Adjusting Print Positions

You can adjust the supply, print, and margin positions by using the control panel buttons. Make sure a batch is not waiting to print, the printer is not paused, or has an error before you change the settings.

To change the supply, print, or margin positions:

1. Press Pause.
2. Press Feed and Clear (at the same time) once to select the supply position, twice to select the print position, and three times to select the margin position. These buttons act as toggle switches between the three (supply, print, and margin) position adjustments.

When you select the position to change, the current setting is displayed.

3. Press Feed to decrease the current position by one dot or press Feed for two seconds to decrease the value by 10 dots.
OR

Press Clear to increase the current position by one dot or press Clear for two seconds to increase the value by 10 dots.

If the position has a negative value, the supplies light is on.

After you adjust the position (and release the buttons), the setting is displayed.

4. Press Pause when you are done making adjustments.

Resend the format so these changes take effect. Change the settings after the batch is done printing.

Review the following definitions for the different print position adjustments.

Supply Position

Adjusts the machine to print at the vertical 0,0 point on the supply. Increase the supply position to move print up, decrease to move print down on the label. The range is -300 to 300 dots.

The supply position adjustment should only be made on initial printer setup. For format adjustments, change the print position.

Print Position

Adjusts where data prints vertically on the supply. Increase the print position to move print up, decrease to move print down. The range is -99 to 99 dots.

Margin Position

Adjusts where data prints horizontally on the supply. Increase the margin position to move print to the right, decrease to move print to the left. The range is -99 to 99 dots.

Adjusting the cut angle

To adjust the cut angle:

1. Loosen the thumbscrews.
2. Slightly rotate the knife to the left or to the right. The knife may appear to sit at a slight angle to the printer.
3. Tighten the thumbscrews.

Cut another batch of tags. If you are unable to adjust for a straight cut, call Technical Support.











































Using the Knife

The installed knife is two and a half (2-1/2) inches away from the printhead. Pressing and holding **Feed** for two seconds marks the tag under the printhead to be cut when it reaches the knife. Depending on the length of your supply, you may lose up to two tags after the last batch.















































































—————
The knife operates when the printer is running. If the
Printer is paused, the knife stops cutting.
—————

Font Samples

The following table shows the characters available with Ginetex Font 70 and Font 71. Font 70 can fit five (5) symbols in 22mm (0.88 inches).

															
080	081	082	083	084	085	086	087	088	089	090	091	092	093	094	095
															
064	065	066	067	068	069	070	071	072	073	074	075	076	077	078	079
															
048	049	050	051	052	053	054	055	056	057	058	059	060	061	062	063
															
032	033	034	035	036	037	038	039	040	041	042	043	044	045	046	047

The following table shows the characters available with Nafta Font 72 and Font 73.

															
096	097	098	099	100	101	102	103	112	113	114	115	108	109	190	199
															
080	081	082	083	084	085	086	087	088	089	090	091	092	093	094	095
															
064	065	066	067	068	069	070	071	072	073	074	075	076	077	078	079
															
048	049	050	051	052	053	054	055	056	057	058	059	060	061	062	063
															
032	033	034	035	036	037	038	039	040	041	042	043	044	045	046	047

Care and Maintenance - 4

This chapter tells you how to

- ◆ clear supply jams
- ◆ clear knife jams
- ◆ clean the printhead and platen roller
- ◆ replace a printhead
- ◆ adjust print contrast
- ◆ replace a fuse
- ◆ lubricate the knife

CAUTION

Do not use sharp objects to clean the printhead. This may damage the printer and void your warranty.

Clearing Supply Jams

When you are printing and a jam occurs, the Supplies light on the printer's front panel blinks. To clear the jam:

1. Turn off the printer.
2. Open the cover and printhead assembly.
3. If necessary, remove the supply roll and ribbon.
4. Remove the jammed supply and reload the supply roll.
5. Close the printhead assembly and turn on the printer.
6. Press Feed to position the supply under the printhead.

Clearing a Knife Jam

If tags are jammed in the knife, the printer displays 760 on the LED. To clear a knife jam, you might have to disconnect the stacker from the knife.

1. Turn the printer off.
2. You can see the tag path in the knife by looking through the slot on the top of the knife. Clear the tag path by using a tool, such as a screwdriver or needle-nose pliers, to pull the jammed tags out of the knife.

CAUTION

DO NOT PLACE YOUR FINGERS NEAR THE KNIFE'S BLADE. DO NOT USE EXCESSIVE FORCE TO REMOVE TAGS BECAUSE DAMAGE TO THE KNIFE MAY OCCUR.

3. Turn on the printer. Send a test batch of tags to the printer.

Cleaning

The rate and frequency at which you print determines how often you must clean the printer.

You may need to clean the printhead and platen roller:

- ◆ if there is any lint or debris build up in the supply path
- ◆ whenever you load new supplies
- ◆ daily if your printer is in an excessively dirty, hot, or humid environment
- ◆ when you see voids in the print as shown.



You may have to clean the supply sensor more often if you frequently receive supply error codes.

Paxar recommends that you clean the printhead and platen roller at least once a day when the printer is in use. You may need to clean more frequently depending on usage.

To clean the printhead, supply sensor, and platen roller:

1. Turn off the printer.
2. Open the cover and printhead assembly.
3. Remove the label roll and ribbon (when cleaning the printhead).
4. Clean the platen roller with a dry cloth or small brush. However, if there is adhesive gum build-up on the platen roller, moisten a cotton swab with isopropyl alcohol. Turn the platen roller with your finger and run the cotton swab or dry cloth across it. Make sure the platen roller is clean all the way around.

5. Moisten another cotton swab with isopropyl alcohol. Rub the cotton swab across the printhead and remove any build-up.

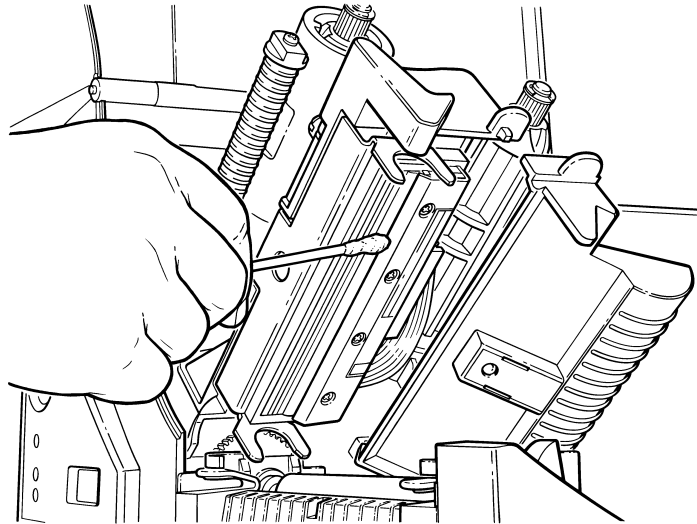

6. Rub the cotton swab across the supply sensor and remove any build-up.

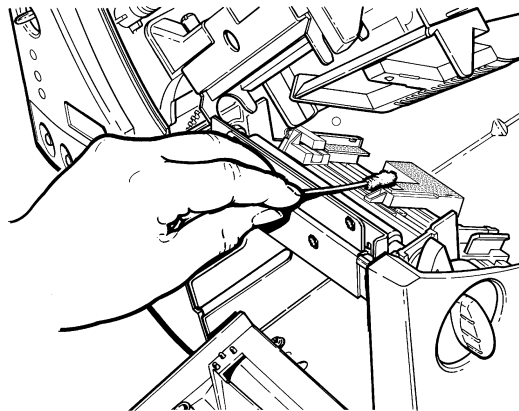

7. Clean the build-up in the supply path.
8. Let the printer dry and reload your supplies.

9. Close the exit cover by pushing firmly on it as shown. Both latches will click into place.

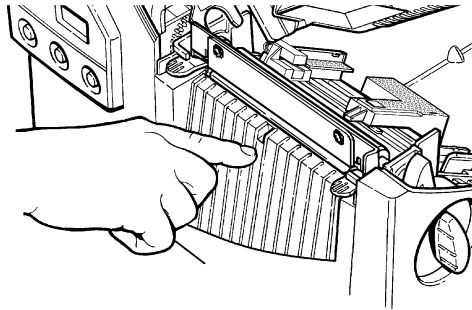

10. Close the cover and printhead assembly.
11. Turn on the printer.
12. Press Feed to position the supply under the printhead.

Replacing the Printhead

You may have to replace the printhead if it is damaged or worn-out. For example, you may see 616 (bad dot or dots) or 768 (printhead failure) error codes.

CAUTION

The printhead is sensitive to static electricity, which can damage the printhead or reduce its life. Ground yourself by touching some metal, such as the printer's metal base, before touching the printhead. Clean the printhead to remove any salt or oil left from handling prior to operation.

To replace the printhead:

1. Turn off the printer.
2. Open the cover.

3. Unlock the printhead by turning the retaining latch.

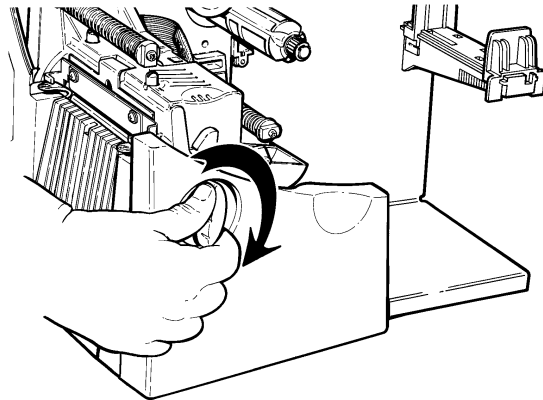

4. Press forward and down on the two latches on top of the printhead assembly as shown. The printhead will drop down.

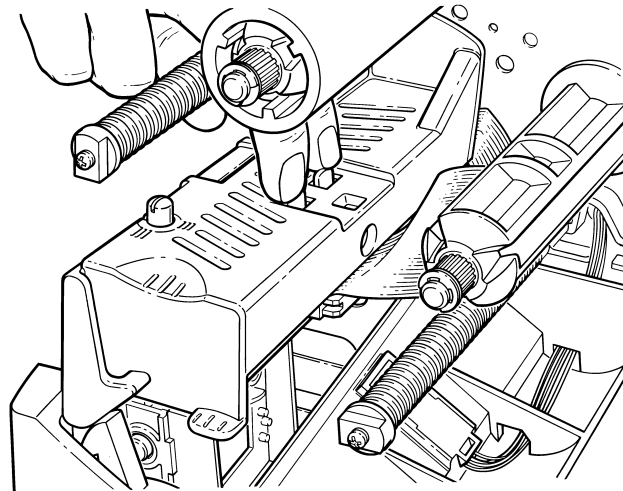

5. Lift the printhead assembly using the printhead tab and push back until the printhead assembly clicks into place.

- Carefully unplug the cable from the printhead as shown.

CAUTION

The printhead is sensitive to static electricity, which can damage the printhead or reduce its life. Ground yourself by touching some metal, such as the printer's metal base, before touching the printhead.

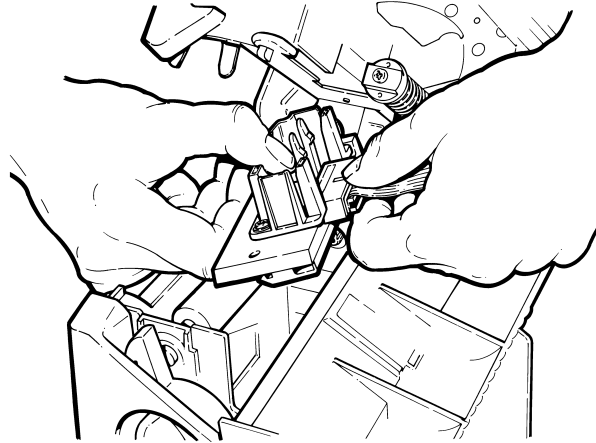

- Carefully plug the cable into the new printhead. The cable connector is keyed, so you cannot incorrectly connect the cable. However, it is normal to feel some resistance when correctly connecting the cable.
- Align the new printhead with the tabs.

9. Snap the printhead into place.

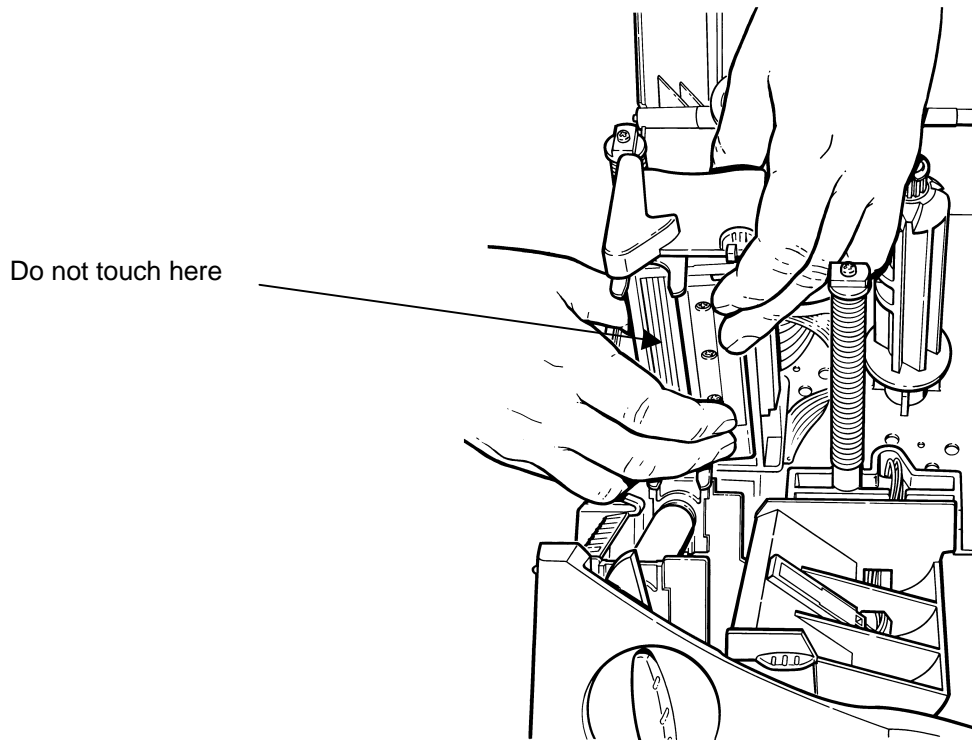

Make sure the printhead cable does not touch the ribbon roll.

10. Clean the new printhead with a cotton swab dipped in isopropyl alcohol to remove any salt or oil left from handling.
11. Let the printhead dry and reload your supplies.
12. Close the printhead assembly and the cover.
13. Turn on the printer.
14. Press **Feed** to position the supply under the printhead.

Adjusting the Print Contrast

You may need to adjust the print contrast if the printing is too light or too dark. Having the correct print contrast is important because it affects how well your bar codes scan and how long your printhead lasts.

Using a thin screwdriver, turn contrast knob clockwise for darker print; turn counter-clockwise for lighter print.

—————
You only have to turn the contrast
adjuster slightly.
—————

Replacing the Fuse

The printer is shipped with a 115 volt or 220 volt slo-blow fuse.

To replace the fuse:

1. Disconnect the printer from the power source.
2. Use a screwdriver to pry open the fuse box in the back of the printer as shown.

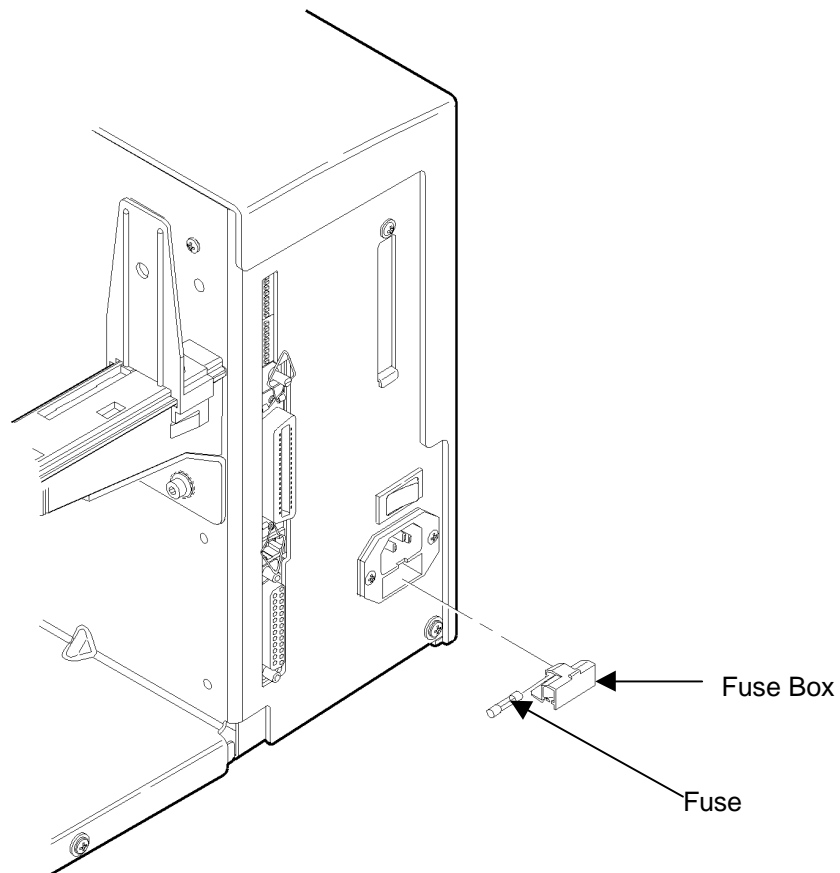

3. Remove the old fuse and insert a new one.
4. Slide the fuse box back into the printer.

Lubricating the Knife

We recommend lubricating the knife after using 15 rolls of supply or performing 100,000 cuts.

To prevent excessive wear on the knife, regularly lubricate the knife cams. The cam are located directly below the guiding holes.

To lubricate the knife:

1. Turn off the printer.
2. Lightly coat a long cotton swab with multi-purpose grease.
3. Insert the cotton swab into one of the two guiding holes until it stops on the cam.
4. Move the cotton swab up and down several times to coat the cam with grease.
5. Repeat steps 2 – 4 for the other cam.
6. Wipe off any excess grease from the top cover of the knife.
7. Turn on the printer.

Troubleshooting - 5

This chapter provides

- ◆ Information about printing a test label.
- ◆ Solutions to minor printing problems.
- ◆ explanations of error messages you may receive while using the printer.

Printing a Test Label

To print test labels:

Press **Feed** and **Pause** simultaneously. Hold for one second and release. Labels similar to these print:

```

                PAXAR
MODEL: M9840   S/M: Version 6.4.0.0
A, 0, 0, 0, 0, 0; B, 1, 1, 0, 0, 0;
C, 0, 0, 0, 0, 0, 0;
D, 1, 0, 2;
E, {, , , ", |, }, ~, --, --, 0d/0a;
F, 3, 1, 0, 0, 1;      (PARA)100
G, 0, 65, 65;
M, D, N, 1280; M, F, N, 640;
M, I, R, 3300; M, R, R, 80;
M, T, R, 20; M, V, R, 3840;
```

```

                PAXAR
MODEL: M9840   S/M: Version 6.4.0.0
TOTAL INCHES:   0000165
HI ENERGY INCHES:0000000
VOLTAGE:        36.53
CONTRAST POT:   +000
PH RESISTANCE:  0840
BAD DOTS:       000
MEMORY:         1024KR/256KN
OPTIONS:        M/R/P/X
DIPSW  000000000000000000
```

The first label shows the printer's configuration by packer (A – G). The second label shows the model number, software version, stock count, voltage, print contrast, printhead resistance, number of bad dots, installed options, and DIP switch settings.

If test labels do not print, press **Feed** and try again. If that does not solve the problem, call Technical Support.

Troubleshooting

This section helps you correct some problems that may occur.

Problem	Action
Error message appears during startup.	Turn off the printer, wait fifteen seconds and then turn on the printer. Call Technical Support if the error message reappears.
Does not print.	Check supply. Check ribbon. Send a corrected batch.
Does not feed.	Set wide/narrow knobs correctly. Try the narrow setting first, if the printing is too light, use the wide setting.
Partially printed data.	Clean the printhead. Send a corrected batch.
Printing shadows or smears	Clean the printhead. Change supply. Check ribbon.
Light printing.	Change supply. Adjust the print contrast. Check wide/narrow knobs. Try the narrow setting first, if the printing is too light, use the wide setting. Check ribbon.
Heavy printing.	Clean the printhead. Change supply. Adjust the print contrast. Check the wide/narrow knobs. Try the narrow setting first, if the printing is too light, use the wide setting. Check ribbon
Voids in printing.	Clean the printhead. Change the supply type. Check ribbon. Leave printhead unlatched when not in use.
Blank labels print or 750 series errors.	Clean supply sensors.

If you cannot fix a problem, call Technical Support.

Error Messages

You may receive the following types of error messages:

- ◆ Data Errors
- ◆ Communication Errors

Some errors numbered 400 – 438 and 500 – 574 are internal software errors. Errors numbered 900 – 999 are hard printer failures. If you cannot clear an error, turn off the printer, wait several seconds and then turn on the printer. Call Technical Support if you receive any error message not listed in this chapter.

Data Errors

Errors 001 to 405 and 429 to 435 are data errors. This type of error indicates that incorrect data was sent to the printer, and the printer is ignoring it. Your System Administrator should correct the packet and send it back to the printer.

Error	Description / Action
001	Packet ID number must be 1 to 999.
002	Name must be 1 to 8 characters inside quotes or a printer-assigned name (“ ”).
003	Action must be A (add) or C (clear).
004	Supply length is invalid.
005	Supply width is invalid.
006	Storage devise must be R (volatile RAM).
007	Unit of measure must be E (English), M (Metric), or G (Dots).
010	Field ID number is outside the range 0 to 999 .
011	Field length exceeds 2710 .
012	Row field position is greater than the maximum stock dimension.
013	Column field position is greater than the maximum stock dimension.
014	Font selector is invalid.
015	Character rotation must be 0 (0 degree), 1 (90 degree), 2 (180 degree), or 3 (270 degree).
016	Field rotation must be 0 (0 degree), 1 (90 degree), 2 (180 degree), or 3 (270 degree).
017	Field restriction must be V (variable) or F (fixed).

- 018 Code page selection defined in the field must be **0** (Internal), **1** (ANSI), **2** (DOS 437), or **3** (DOS 850).
- 020 Vertical magnification must be **1** to **7**.
- 021 Horizontal magnification must be **1** to **7**.
- 022 Color must be **B**, **D**, **O**, **R**, or **W**.
- 023 Intercharacter gap must be **0** to **99** dots.
- 024 Field justification must be **B** (balanced), **C** (centered), **E** (end), **L** (left), or **R** (right).
- 025 Data length is outside the range **0** to **2710**.
- 030 Bar code height must be at least **20** (English), **51** (Metric), **40** (Dots), or is not within the supply dimensions.
- 031 Human readable option must be **0**, **1**, **5**, **6**, **7**, or **8**.
- 032 Bar code type is invalid.
- 033 Bar code density is invalid.
- 040 Line thickness must be **0** to **99** dots.
- 041 Line direction must be **0**, **90**, **180**, or **270**.
- 042 The line segment or box end row is defined outside of printable area.
- 043 The line segment or box end column is defined outside of printable area.
- 044 Dot pattern for line or box must be “ “.
- 045 Line length is defined beyond the maximum length.
- 046 Line type must be **S** (segment) or **V** (vector).
- 051 Imaging mode in the graphic header must be **0**.
- 101 Format referenced by batch is not in memory.
- 102 Print quantity is outside the range **0** to **32000**.
- 104 Batch mode must be **N** (new) or **U** (update).
- 105 Batch separator must be **0** (off) or **1** (on).
- 106 Print multiple is outside the range **1** to **999**.
- 107 Cut multiple is outside the range **0** to **999**.
- 108 Multiple part supply is outside the range **1** to **5**.
- 109 Cut type is invalid.
- 200 Option number must be **1**, **4**, **30**, **31**, **42**, **50**, **60**, or **61**.
- 201 Copy length is outside the range **0** to **2710**.
- 202 Copy start position must be **1** to **2710**.
- 203 Destination start position must be **1** to **2710**.

- 204 Source field must be **0** to **999**.
- 205 Copy type must be **1** (Copy after rules) or **2** (Copy before rules).
- 206 Increment / Decrement selection must be **I** (increment) or **D** (decrement).
- 207 Incrementing start position must be **0** to **2710**.
- 208 Incrementing end position must be **0** to **2710**.
- 209 The incrementing amount must be **0** to **999**.
- 210 Security value for a PDF417 bar code must be **0** to **8**.
- 211 Narrow element value is less than **1** or greater than **99**.
- 212 Wide element value is less than **1** or greater than **99**.
- 213 Dimension must be **1** to **30** for a column or **3** to **90** for a row.
- 214 Truncation code must be **S** (standard) or **T** (truncated bar code).
- 215 Aspect code must be **C** (columns) or **R** (rows).
- 216 Option definition must be **S** (set) or **T** (template).
- 217 Input device must be **D** (default), **H** (host), **K** (keyboard), **N** (none), or **S** (scanner).
- 218 Pad direction must be **L** (from left) or **R** (from right).
- 219 Pad character is outside the range **0** to **255**.
- 220 Check digit selection must be **G** to generate check digit.
- 221 Primary or secondary price format is outside the range **1** to **15**.
- 222 Data type restriction is outside the range of **1** to **6**.
- 223 Option is not valid for the field.
- 224 Bar code Intercharacter gap must be **0** to **99** in printer dots.
- 251 Power up mode must be in **0** (online) or **1** (offline).
- 252 Language selection must be **0** (English).
- 253 Batch separator code must be **0** (off) or **1** (on).
- 254 Slash zero selection must be **0** (standard zero) or **1** (slash zero).
- 255 Supply type must be **0** (black mark), **1** (die cut), or **2** (continuous).
- 256 Ribbon selection must be **0** (direct) or **1** (transfer).
- 257 Feed mode must be **0** (continuous) or **1** (On-Demand).
- 258 Supply position is outside the range.
- 259 Contrast adjustment must be **-390** to **1000** dots.
- 260 Print adjustment must be **-99** to **99** dots.
- 261 Margin adjustment must be **-99** to **99** dots.
- 262 Speed adjustment is invalid.

- 263 Primary monetary symbol is invalid.
- 264 Secondary symbol selection must be **0** (none) or **1** (primary secondary sign).
- 265 Monetary decimal places must be **0** to **3**.
- 266 Character string length in Packet **E** must be **5** (MPCL control characters) or **7** (ENQ/IMD command character).
- 267 Baud rate selection must be **0** (1200), **1** (2400), **2** (4800), **3** (9600), **4** (19.2), or **5** (38.4).
- 268 Word length selection must be **0** (7 bits) or **1** (8 bits).
- 269 Stop bits selection must be **0** (1 bit) or **1** (2 bits).
- 270 Parity selection must be **0** (none), **1** (odd), or **2** (even).
- 271 Flow control selection must be **0** (none), **1** (DTR/DSR), **2** (CTS/RTS), or **3** (XON/XOFF).
- 272 Internal code page selection must be **0** (internal), **1** (ANSI), **2** (DOS 437), or **3** (DOS 850).
- 273 Cut adjustment must be **-300** to **300** dots.
- 282 RS232 Trailer string is too long. Use a maximum of **3** characters.
- 283 ENQ Trailer string is too long. Use a maximum of **3** characters.
- 284 The buffer type must be **T** (transmit), **R** (receive), **I** (image), **F** (format, batch date and graphics), **D** (downloadable fonts), or **V** (vector/scalable fonts).
- 285 The storage device type must be **N** (non-volatile RAM) or **R** (volatile RAM).
- 286 The buffer size is invalid.
- 287 The printhead width must be **0**.
- 290 Action must be **0** (disable) or **1** (enable) for Backfeed Control.
- 291 Dispense position must be **50** to **200** dots and/or the backfeed distance is greater than the dispense position.
- 292 Backfeed distance must be **10** to **200** dots.
- 310 Check digit scheme number must be **1** to **10**.
- 311 Modulus must be **2** to **11**.
- 314 Check digit algorithm must be **D** (sum of digits) or **P** (sum of products).
- 325 Duplicating direction must be **0** or **1**.
- 327 Amount of row adjustment must be **0** to **999**.
- 328 Duplicate count must be **0** to **999**.
- 340 Bitmap line encoding must be **H** (hex) or **R** (run length).
- 350 Font selector must be **1** to **9999**.
- 351 Font data length must be **68** to **16384**.

- 352 Insufficient font memory is available for the downloaded font.
- 380 Job request is outside the range **0** to **4**.
- 400 Invalid character following {.
- 401 Internal software failure. Call Technical Support.
- 402 Field separator is not in the expected location.
- 403 Field separator was not found.
- 404 The number of string that is currently being processed is too long.
- 405 Too many fields exist in the format. You cannot have more than 1000 fields in the format. Lines, boxes, and constant text fields count as fields.

Communication Failures

Errors 409 to 413 usually indicate a communication failure. These errors happen when the host and the printer cannot communicate. Ask your System Administrator for help.

Error	Description/Action
409	Printer memory is full. Delete unnecessary formats or graphics from memory. Try run length encoding for large graphics.
410	Parity mismatch.
411	Framing error (baud rate mismatch). This error may appear when you turn off the printer.
412	Flow control mismatch.
413	Receive buffer is full. Check flow control settings.
414	The internal keyboard buffer is full or you need a new keypad.
427	Format name must be 1 to 8 characters inside quotes or a printer-assigned name (“”).
428	Batch name is invalid or graphic not found.
429	A field number appears more than once in a format.
430	The format uses a graphic file that cannot be found.
433	The batch references a field number that does not exist in the format.
497	An error occurred during the loop back test on the parallel port. Call Service.
499	An error occurred during the loop back test on the serial port. Call Service.

Data Formatting Errors

Errors 571 to 618 are data formatting errors. This type of error happens when a field prints incorrectly. Your System Administrator can correct the format, batch, or graphic packet and send the print job again. For errors 571 to 614, the printer will still print, but the data may be incomplete, missing, or wrong.

Error	Description/Action
571	UPC or EAN bar code data length in the batch doesn't fit the format.
572	Batch data doesn't fit the format, the field contains blanks, or data mismatch.
573	Batch data in price field doesn't fit the format or the field contains blanks.
574	Batch data in check digit scheme doesn't fit the format, or the field contains blanks.
575	The graphic included in your format could not be found.
600	Imaging error because the batch was refused.
601	An error occurred while the batch was imaging.
602	The batch was not found during imaging.
611	Font, bar code, or density in the batch doesn't fit the format.
612	Batch data is missing or doesn't match the format.
613	Reference point off tag.
614	Portion of field off tag.
615	Bar code width is greater than 16 inches, or keywords of PDF417 bar code exceed 928 .
616	A bad dot falls on a bar code that cannot be shifted. Call Service or replace the printhead.
618	Magnification must be 1 to 7 .
620	Font and printhead density mismatch. Check the font or verify the correct printhead (203 dpi or 300 dpi) is installed.

Machine Faults

Errors 700 to 765 happen when there is a problem with the printer.

Error	Description/Action
700	An error is pending, and the printer cannot continue with the batch.
701	Printer received a command that it cannot execute while it is running.
702	Check your printer's SETUP settings.
703	The printer sensed a calibration of different-sized black marks.
704	Printer didn't detect a sense mark within the maximum feed length or out of supplies. Check or load supplies.
705	Invalid batch received.
750	Printhead is overheated. Turn off the printer and let it cool.
751	Printer didn't detect a sense mark when expected.
752	Printer detected a sense mark in the wrong place.
753	Printer detected a sense mark that is too long.
754	Out of ribbon or ribbon jam. Check or load ribbon. Remove any slack in the ribbon by turning the take-up reel clockwise. Load a new ribbon.
755	Printhead is open. Close the printhead.
756	Out of supplies. Load supplies.
757	Reload supplies (supply length mismatch).
758	The supply was not seen or the On-Demand sensor is not working correctly. Check for a supply jam. Clear the supply path or reload supplies. This error may occur if you remove a label too quickly in the On-Demand mode. The printer does not recalibrate after this error.
759	Knife is not moving. Call Technical Support.
760	Knife jam. Call Technical Support.
761	Stacker is full or jammed. Empty the stacker before continuing.
762	Low battery. Recharge the battery.
763	Waiting to dispense label. Press Feed .
764	Verifier failure. Call Technical Support.
765	The printhead has less than four bad spots. The printer can shift bar code fields to avoid bad dots. Press Clear to continue printing. Print a test label to confirm the number of bad dots.

- 768 Printhead has more than 10 bad dots or is not connected. Make sure the printhead is connected and if necessary, replace the printhead.
- 770 The print motor is not ready. Call Technical Support.
- 771 The format specified by the application was not found. Reload your application and format and try again. If the problem continues, call Technical Support.
- 790 The printer is busy. Wait until the printer is idle (not receiving data or no batch waiting to print) before you send any packets. This error may occur when you try to print a test label if the printer is busy.
- 791 The printer has an error pending. Turn off the printer. Wait 15 seconds and turn it back on. Resend the packets. If the problem continues, call Technical Support.
- 792 The printer is not initialized. Call Technical Support.
- 793 The printer job queue is full. Turn off the printer. Wait 15 seconds and turn it back on. Resend the packets. If the problem continues, call Technical Support.

Errors numbered 900 – 999 are hard printer failures. Call Service if you receive these messages.

—————
Error 911 may appear when you turn off the printer.
—————

Specifications & Accessories - A

Printer

Height:	12.5 inches (318 mm)
Width:	12 inches (305 mm)
Depth:	13 inches (330 mm)
Weight:	29 lb. (13 kg)
Shipping Weight:	33 lb. (15 kg)
Power:	115 Vac, 60Hz, 100 Vac, 50/60 Hz, 230 Vac, 50Hz
Operating Limits:	For Thermal Transfer (ribbon) 40° to 95° F (4° to 35° C)
Printhead:	Thermal at 4 inches (102 mm) wide 300 dpi (11.8 dots per mm)
Printing Method:	Thermal Transfer (ribbon)
Print Speed:	4.0 inches (102 mm) per second

Supply Specifications

Supply Types:	Thermal Transfer Perforated Fabric Labels
Fabric Label Kits:	Kits include fabric and ribbon
Paxar Systems:	The fabric is available in standard widths, ranging from 1.0 inch (25 mm) to 1.75 inches (45 mm), perforated to standard lengths.
Paxar Europe:	The fabric is available in 35 mm or 50 mm widths.
Sizes:	Supplies are available in widths ranging from 1.0 inch (25 mm) to 4.25 inches (108 mm) and lengths ranging from 1.0 inches (25 mm) to 12.5 inches (318 mm)

Contact your Paxar Representative for more
Information about kits and approved supplies.
Additional configurations may be available.

If you experience label jamming with narrow
Supplies in humid environments, store
Supplies separately from the printer in a dry,
Less humid environment.

Ribbon Specifications

Ribbon Storage: Do not leave ribbon in direct sunlight, high temperatures, or high humidity.

Ribbon Type: DK1111 (Paxar Systems)

Ribbon Widths: DK1111 is available in the following widths:

1.3 inches (33 mm)

1.61 inches (41 mm)

2.16 inches (55 mm)

4.1 inches (105 mm)

—————
For best results, use a ribbon that is 0.25
Inches (6.35 mm) wider than your fabric.
—————

Ribbon Length:	23,600 inches (600 meters)
-----------------------	----------------------------

—————
Contact your Paxar Representative for more
Information about approved ink products.
Additional configurations may be available.
—————

Accessories

- ◆ International Fonts
- ◆ Internal TwinAx/CoAx Protocol Convertor
- ◆ LAN Print Server RJ-45 Connector (10BaseT)
 BNC Connector (10Base2)
- ◆ Printhead Assembly Kit
- ◆ Ribbon Take-up Core (available in two, three, or four inches)
- ◆ RTS/CTS Communication Cable – 119806

To order supplies or call customer support, use the number on the back of this manual.

Contacting Paxar

When ordering supplies in the U.S.A.

1-800-96PAXAR or (570) 888-6641

Fax: (570) 888-5230

When ordering spare parts in the U.S.A.

1-800-96PAXAR or (570) 888-6641

Fax: (570) 888-7416

For Machine Service or Technical Support in the U.S.A.

(570) 888-9116

Fax: (570) 888-7416

For International assistance, call your Paxar Representative

www.paxar.com