

### Technical Support

 1.800.672.7298

 [supportUS@paxton-access.com](mailto:supportUS@paxton-access.com)

Technical help is available: Monday - Friday from 02:00 AM - 8:00 PM (EST)  
Documentation on all Paxton products can be found on our web site - <http://www.paxton-access.com/>  
For instructions in alternative languages - <http://paxton.info/1000>

### Suitability

Security sensitive doors 

Wet environments 

Mounted on metal surface 

Readers mounted together 

### Mounting



This reader is designed to read Paxton Tokens (Hitag2) and EM4100 tokens.  
It will provide Clock and Data output for Paxton (Net2 / Switch2).

## Options

Part number	Description
390-747-US	PROXIMITY metal reader

## Wiring

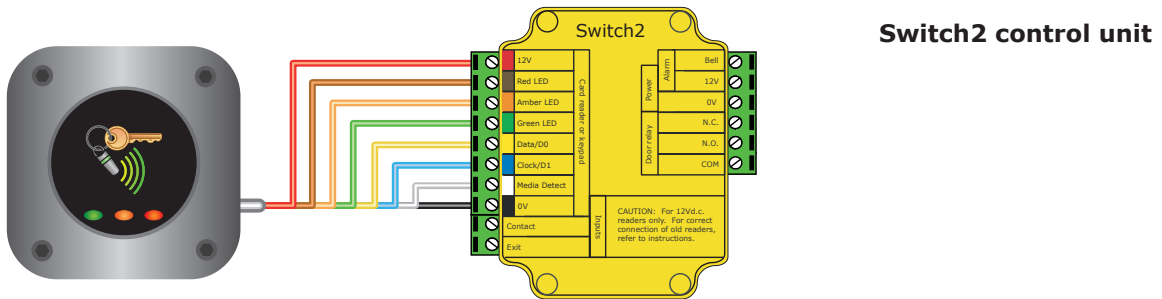
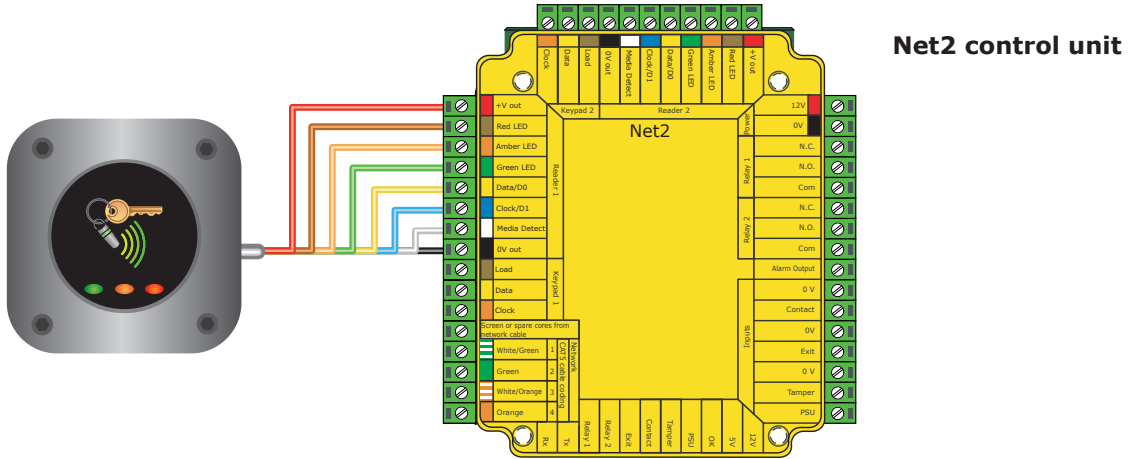

## Cable extensions

### Cable Specification

Use	Max length	Type
Reader / Keypad	500 feet	8 core shielded, Beldon 9538, Alpha 1298C (22AWG) or equivalent

Parts list	
Part number	Description
Fitting Kit fk1-058	4 off - M5x20 Security button socket pin head machine screw
	4 off - No8 x 1 <sup>1</sup> / <sub>2</sub> in pozi round woodscrew - zinc
	4 off - Wall plugs 35mm, red
	1 off - 3mm socket pin head Allen key

## Reader installation and test

Drill a hole in the surface for the rear data cable. Secure the mounting plate to the surface with four screws as per fitting diagram on page 1. Suitable screws and fixings are provided for fitting the plate to a wall. Mount the reader on its backplate and secure with the security screws using the Allen key supplied. Ensure the data cable has free access at the rear.

The reader will bleep and all the LEDs should display after powering on the control unit. Presenting a user card to the reader will cause the LEDs to briefly change to a single Green or Red LED.

Check the following FAQs section for assistance if any problems are encountered.

## Maintenance

Following the completed installation of this equipment, no further maintenance or testing is required.

It is advisable to ensure that any third party backup power supplies or recovery procedures are checked regularly to ensure that the operation of the Paxton system is not compromised.

## Product compliance and limitations

To comply as a UL listed installation, the following conditions must apply:-

Server based functions (Antipassback, Time and Attendance, etc) have not been evaluated by UL and cannot be used for UL 294 installations.

The use of Wiegand readers and the configuration software has not been evaluated by 'UL'

Wiring: - Where an equivalent cable / wire is used it must be ' UL Listed ' All interconnecting devices must be UL Listed.

Wiring methods shall be in accordance with the National Electrical Code (ANSI/NFPA70), local codes, and the authorities having jurisdiction.

For CAN/ULC-S319 installations, terminals, leads and wiring methods must comply with CSA, C22.1, Canadian electrical code, Part 1, safety standards for electrical installations.

The use of any add-on, expansion, memory or other module manufactured or supplied by the manufacturer's representative will invalidate the CAN/ULC-S319 certification.

This device complies with Industry Canada licence-exempt RSS standard(s). Operation is subject to the following two conditions: (1) this device may not cause interference, and (2) this device must accept any interference, including interference that may cause undesired operation of the device.

## FCC Compliance

This device complies with Part 15 of the FCC Rules. Operation is subject to the following two conditions: (1) this device may not cause harmful interference, and (2) this device must accept any interference received, including interference that may cause undesired operation. Changes or modifications not expressly approved by the party responsible for compliance could void the user's authority to operate the equipment.

## Technical Help

Here is the list of topics about this product that receive the most technical support inquiries. We list them here to help you speed up the installation and trouble shooting process.

### 1 - Readers/Keypads not working.

- Software settings - Confirm that the settings of the reader or keypad are correct.
- Connections - Check the wiring and integrity of the connectors. If possible, test this reader on the other port.
- Extended cable - Belden 9538/9540 should be used up to a maximum of 500 feet. Twisted pair alarm cable should not be used. To confirm that an extended reader cable is not at fault, wire the reader directly to the port.
- Supply voltage - Confirm that the voltage is within specification. (see table)
- User token - Confirm that the user token used for testing is OK by presenting it to a known working reader.
- Interference - Confirm whether the reader works when tested 'in hand' and not mounted on the wall. PROXIMITY readers should not be mounted back to back or close to other RF devices.

### 2 - Readers / Keypads - Extending cable.

Only Belden CR9538 / 9540 or a UL equivalent can be used for cable extensions. The maximum run is 500 feet.

### 3 - Net2 - Using a door reader as a desktop reader.

It is possible to configure a door reader to operate as a desktop reader:

- 1 - Select the doors menu in the left hand Net2 pane.
  - 2 - Click on the door you wish to change the reader to act as a desktop reader.
  - 3 - Under the relevant reader tab, change the reader operating mode to 'Desktop Reader'.
  - 4 - The PC displays 'Would you like to accept desktop reader events from this reader at the PC?' ; click 'Yes'
- Now when you present a blank or existing token to that reader it will allow you to add this new token or edit the existing one.

**NOTE:** Remember to return the operating mode to the original setting once the cards have been read or users will not be able to gain access through the reader.

KP Reader - Ensure that Keypad type is set to 'None', otherwise the Desktop reader option will not be available.

### 4 - Net2. What to do if a user has no access - Check the reader LED's when a card is shown.

- No LED's - the reader has no power.
- No change in display - try the card on a known working reader. If there is still no response, replace the card.
- Green LED flashing when a card is presented; check relay 1 LED to check for activity and also the lock wiring.
- Red LED is flashing when a card is presented; check the validity of the user at the PC.
  - Check user's access level and ensure they should have access by clicking on Current Validity.
  - Check the 'Expires end' date and confirm this has not been past.
- Reinstate the ACU from the doors screen. Select the ACU's you wish to reinstate and then click OK.

Specifications			
Environment	Min	Max	
Operating temperatures - all items	-35 °C ( -31 °F )	+66 °C ( + 151 °F )	
Waterproof	IPX7		Outdoor use
Cable length			10 feet
Electrical	Min	Max	
Voltage			12V DC
Current		110 mA	
Carrier frequency			125 kHz
Clock and data bit period			600 µs
Read Range	Token	Keyfob	Hands Free Token
	2 inch	11/2 inch	Not Compatible
Dimensions	Width	Height	Depth
	3 inch	3 inch	1 inch