

Technical Support

1.800.672.7298

supportUS@paxton-access.com

Technical help is available: Monday - Friday from 02:00 AM - 8:00 PM (EST)

Documentation on all Paxton products can be found on our web site - <http://www.paxton-access.com/>

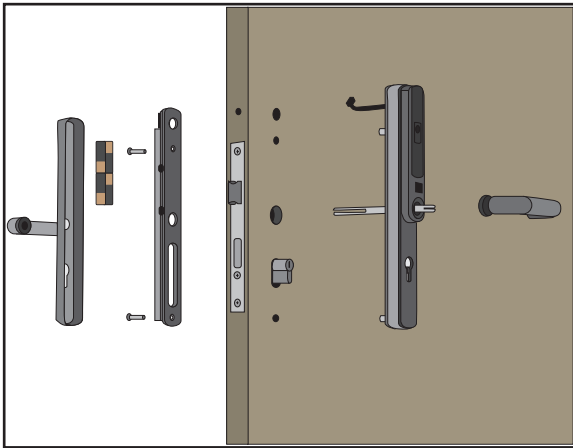

This wireless unit requires a Net2Air bridge to communicate with the server PC.

Net2Air Site Surveyor (690-200-US).

This access control unit uses wireless communication. It is recommended that a Net2Air site surveyor is used to determine the best position for the bridge and control units.

This unit requires Net2 v4.23 or later software. Call Technical Support if you require advice.

Parts list

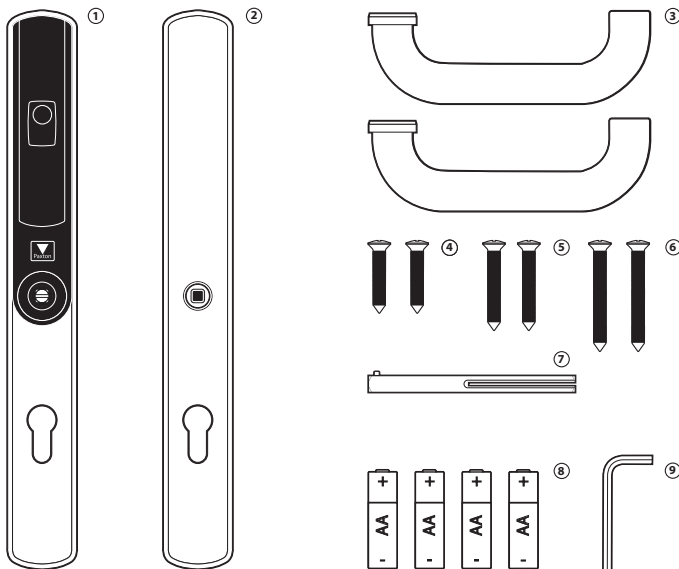

- 1) Front Lock Assembly
- 2) Rear Lock Assembly
- 3) Door Handle x 2
- 4) Mounting screw (1 1/4") x 2
- 5) Mounting screw (1 1/2") x 2
- 6) Mounting screw (1 3/4") x 2
- 7) 8 mm Spindle
- 8) AA battery x 4
- 9) 4 mm Allen Key

Tools List

Power Drill
Drill bits 3/8", 5/8"
Philips screwdriver

Small flat blade terminal screwdriver
Pencil
4mm Allen key (supplied)

Installing the hardware

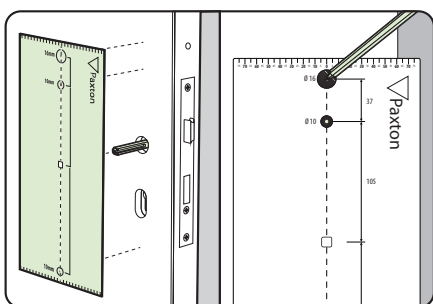

Step 1 - Marking out

The lock (not supplied) must first be fitted to the door.

Slide the spindle through the lock to allow the template to locate over it. Ensure that the template is square to the door edge by using the top and bottom ruler scales.

Mark the $2 \times \frac{3}{8}$ " and $1 \times \frac{5}{8}$ " holes. Remove the template and repeat the procedure for marking out the other side of the door.

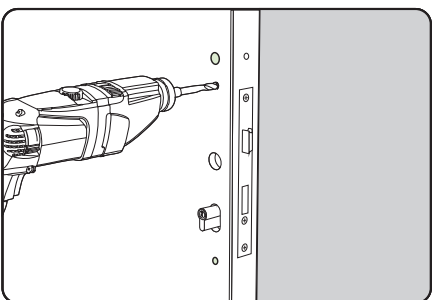

Step 2 - Drilling

Drill the $2 \times \frac{3}{8}$ " holes for the mounting screws and $1 \times \frac{5}{8}$ " hole for the wiring harness.

To ensure accuracy you should drill these holes from both sides of the door towards the centre. This also avoids the risk of damaging the door face when the drill breaks through.

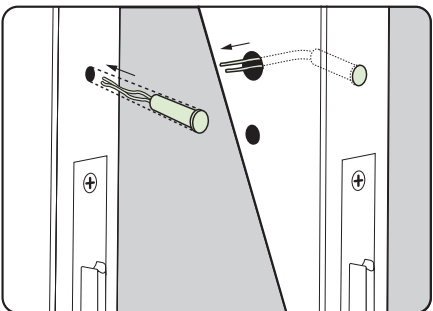

Step 3 - Contact switch (optional)

If a contact switch is to be fitted, an additional hole is required in the edge of the door.

Drill a hole of the required size to receive the switch assembly. This should intersect the $\frac{5}{8}$ " hole drilled previously to take the wiring harness.

Feed the door contact wires through the door to exit on the inside.

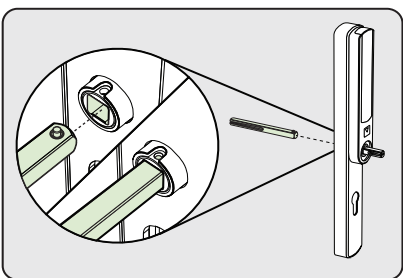

Step 4 - Attach the Spindle

The spindle is locked into the front lock assembly by means of a spring loaded pin.

Ensure that the spindle pin and the hole in the square drive are in alignment before depressing the pin and sliding the bar into the assembly. The pin will then latch into the hole securing the spindle in place.

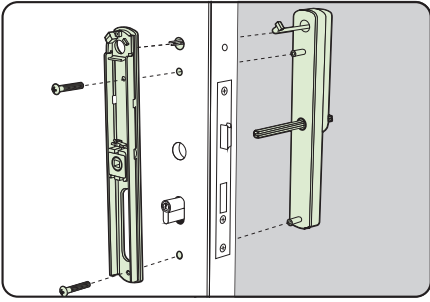

Step 5 - Mounting on the door

Present the front lock assembly to the door passing the wiring harness through the $\frac{5}{8}$ " hole.

Present the rear lock assembly to the door and join the two parts together with the two mounting screws.

Mounting screws are provided in three lengths.

Short - Door width $1\frac{1}{4}$ " to $1\frac{3}{4}$ "

Med - Door width $1\frac{1}{2}$ " to 2"

Long - Door width $1\frac{3}{4}$ " to $2\frac{1}{4}$ "

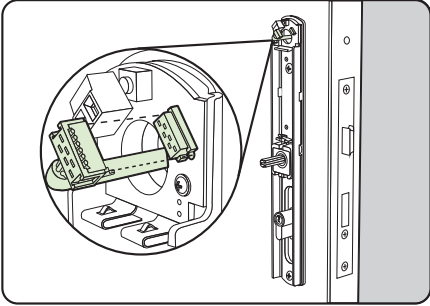

Step 6 - Wiring

Plug the wiring harness into the socket in the rear lock assembly.

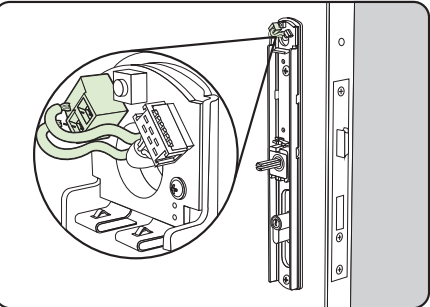

Step 7 - Wiring (contact switch option)

Where a contact switch is fitted, connect the wires to the terminal block provided on the pcb.

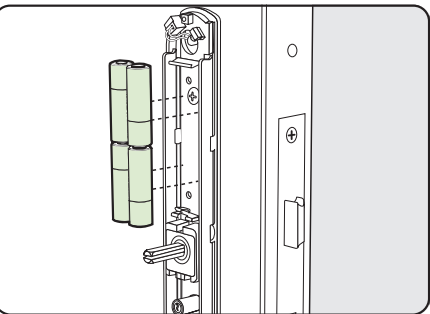

Step 8 - Fitting the batteries

Clip in the 4 x AA batteries with reference to the label displayed below the holder assembly.

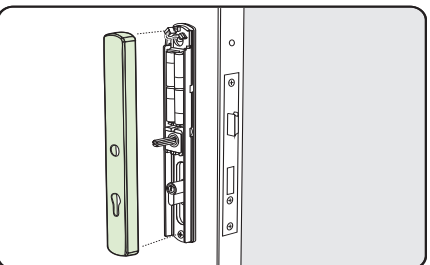

Step 9 - Fitting the rear cover

Locate the top of the cover over the housing and push flush to the door.

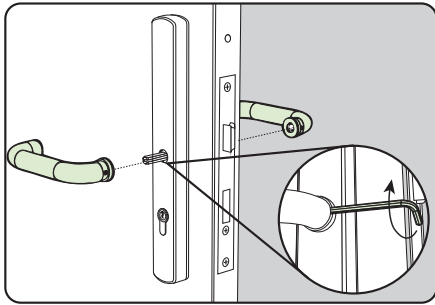

Step 10 - Fitting the handles

Fit the two handles and secure with the grub screws provided.

Check the mechanical operation of the lock and that the handles operate freely.

Software installation

The Net2 software should be loaded on the controlling PC with at least one Net2Air bridge installed.

Full documentation is supplied with the Net2Air bridge unit and also from the website as follows:

AN1051 - Installing Net2 software < <http://paxton.info/1520> >
Ins-40084-US Net2Air USB bridge < <http://paxton.info/1453> >
Ins-40085-US Net2Air Ethernet bridge < <http://paxton.info/1192> >

Download the latest version of Net2 software at: <http://paxton.info/1438> before commissioning this product.

The current specification for compatible PC hardware, network and operating systems is available on our website at the following link: <http://paxton.info/720>

Some of the Net2 features (e.g. Fire alarm integration, Anti-passback) are not available on this product as wireless communication is not suitable for data critical applications.

Enrolling a PaxLock

A PaxLock must bind to a Net2Air bridge before it will enrol itself onto the Net2 system. The term 'bind' is used to denote the fixed relationship between a wireless unit and its bridge.

1. Create a user record in the database and assign a Net2 token to the user. (This record can be deleted after the installation is complete.)
2. You must now wake up the PaxLock by using the front push button.
3. Present the user token to the PaxLock.
4. The Red and Green LED's will flash alternately while the unit configures.

The PaxLock transmits the number and waits for a response from Net2. If more than one bridge replies, the unit checks the signal strength and selects the strongest bridge to communicate with. The Net2 software confirms that the token number is in the database and registers the PaxLock/bridge binding. The LED's will go out when the process has finished.

The software must be in commissioning mode which is the default setting. If this has been turned off it must be enabled in the Server Configuration Utility.

An entry is then made on the Doors screen and a special icon is used to denote the wireless connection. 

Net2 has NO PaxLock detection function. It is recognised that there could be security issues if the wireless units were detectable from outside the site. During installation, a PaxLock unit binds to a Net2Air bridge which will then only talk to registered units.

Devices cannot be added to the system if commissioning mode is disabled.

Software configuration

Door name: Name the Door.
Door open time: Set the door open time.
Unlock the door during: Holds the door unlocked during this timezone. - Set to 'At No Time' for normal user operation.

Reader: Local settings for the reader.
Output: Configures the lock for timed release or toggle mode.
Alarm: Enables/Disables the door alarm functions. (requires contact switch)
Events: Shows the events for this control unit only.
Access Rights: Lists users who have access through this door.

Normal Operation - LED Indications

Presenting a valid user token to the unit will cause the LED to briefly flash Green and the door will unlock. The presentation of a barred or unknown user token is indicted by a Red LED display.

The external handle is only engaged once access has been granted. The inside handle is always engaged.

LED indications	
Green flash	A valid user card has been presented and the handle is engaged
Red flash	An invalid user card has been presented - No access granted
Red and Green flash together	The unit is not bound to a bridge.
Red and Green flash alternately	The unit is configuring - Please wait.

Net2Air wireless communication

The access control unit connects to the Net2 software running on the PC using Paxton Net2Air proprietary wireless technology. A Net2Air bridge enables communication from the Net2 software to the Paxton wireless products.

Radio signals do not always behave as you might expect. For example, a cell phone that displays a full signal on one part of the site will lose signal completely only a few feet away. These problems can be addressed by using the Net2 site surveyor kit (690-200-US)

See also: [AN1095 - Net2 nano - How does it work? < http://paxton.info/974 >](http://paxton.info/974)
[AN1096 - How to plan a Net2 nano installation < http://paxton.info/975 >](http://paxton.info/975)
[Ins-30096-US - Net2Air site surveyor < http://paxton.info/1193 >](http://paxton.info/1193)

Radio frequency

The unit is set to channel 11 (2.405 GHz). This product should not be installed within 10 feet of any other radio (LAN/Wi-Fi) equipment to reduce the possibility of interference.

Sleep mode

The PaxLock is a standalone unit and stays asleep while there is no user activity. The Net2 server cannot wake up the unit. If the PIR is activated or the front button is pressed, it powers up the reader circuits in readiness for a token read. Should nothing occur within 3 seconds, the unit will go back to sleep.

If a token is read, then the PaxLock moves into full operation. The token number is checked against the stored database and access is granted or denied as per a standard Net2 control unit.

The PaxLock now sends this data via its Net2Air bridge connection to the Net2 server software. If any updates need to be sent to the unit, including changes to the user data, these are transmitted back. The unit will then go back to sleep waiting for further activity.

After 1 hour of inactivity, the PaxLock will send a heartbeat to the Net2 PC which responds with any updates. This keeps the PaxLock updated even when there is no activity at the door and maximises battery life.

During the 1 hour sleep period, any changes made at the PC will not be received. If an immediate update is required, the unit must be woken up by pressing the front button or presenting a user card.

Where a door is held unlocked by software, it will still receive updates every hour. To force an immediate update, the unit must be activated by pressing the front button. A card can then be presented to initiate the update request.

Low power mode

Low Power mode is available as a global setting in the Net2 server configuration utility or on individual Doors screens. It is very useful for units that require low activity but have a high rate of passing traffic (e.g. corridor).

In low power mode the PaxLock must be woken up by pressing the front button. This ensures that incidental handle or PIR activity does not cause an unnecessary drain on battery power or communications activity.

If woken, the PaxLock will initiate a transmission if it has been asleep for more than 1 hour. It will always initiate an update every six hours.

Low battery warning

As the battery voltage falls the unit will update the Net2 server with its battery condition. This voltage level is displayed as a colored battery icon alongside the door in the Doors screen. When the batteries approach the end of their life an Event is sent to Net2.

Using Net2 Trigger and Actions, an email or text message can be sent to a staff member or engineer to schedule a battery change.

Battery replacement

1. Remove the inside handle from the door by removing the securing grub screw.
2. Remove the cover by holding the bottom edge and pulling it towards you. The cover will lift off at the top when the bottom edge is clear of the housing.
3. Remove and replace batteries.
4. Refit the cover and handle.

Recovery from a flat battery

Should the battery pack become discharged, the latch will no longer function. This could be in the locked or unlocked state.

Holding a PP3 9V battery up to the contacts on the bottom of the unit will allow the circuitry to operate normally.

A valid user card can then be used to open the door to access the batteries.

Where the lock has a key override, this will always be available to unlock the door and gain entry.

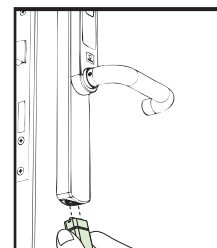

-ve +ve

PaxLock reset

The PaxLock holds address information for the bridge that it is bound to. This will cause problems if the unit is to be used on another system.

The unit requires a hardware reset to clear its bridge information. This is achieved as follows:

1. Remove the inside handle from the door by loosening the securing grub screw.
2. Remove the cover by holding the bottom edge and pulling it towards you. The cover will lift off at the top when the bottom edge is clear of the housing.
3. Locate the red reset button at the top of the unit.
4. Hold the button down and wake up the unit by pressing the front push button.
The unit will give a beep when the reset has started. You can now release the reset button.
5. The Red and Green LED's will both flash until the process has finished.
6. Refit the cover and handle.
7. You can now enrol the unit.

Specifications

Features	Min	Max	
Number of Cards		10,000	
Access Levels		250	
Time Zones		64	
Door open time	1 sec	60 secs	
ACU's per Net2Air bridge - Recommended		10	
Net2Air bridge (data lines) per system		100	
Net2Air wireless range to ACU		65 ft	Use site surveyor
Events stored in ACU with no server connection		3,584	
Read Range	Token	Keyfob	
	1 inch	1/4 inch	
Environment	Min	Max	
Battery Type			4 x AA
Typical Battery Life	2 years or 30,000 ops	3 years or 60,000 ops	Max = Low power mode
Operating temperature - Battery limits	0 °C (-32 °F)	+55 °C (+131 °F)	
External use		IPX4	Yes
Vandal resistance			Low
Voltage		6V DC	
Dimensions	Width	Height	Depth
Reader/Keypad module (Required space on Door)	1 1/2 inch	13 inch	1 3/8 inch
Total outside dimensions (includes handle clearance)	6 1/4 inch	13 inch	4 inch

The declaration of conformity is available on request. Contact details are provided at: <http://paxton.info/596>

This product is not suitable for retail sale. All warranties are invalid if this product is not installed by a trained technician.

FCC Compliance

This device complies with Part 15 of the FCC Rules. Operation is subject to the following two conditions:

(1) this device may not cause harmful interference, and (2) this device must accept any interference received, including interference that may cause undesired operation. Changes or modifications not expressly approved by the party responsible for compliance could void the user's authority to operate the equipment.