

SIGMA[®] REVISION AND M.B.T. REVISION TRAY



TABLE OF CONTENTS

Surgical Technique	Key Surgical Steps Summary	4
	SIGMA® Revision/M.B.T. Revision Tray Knee Surgery	6
	The SIGMA Revision System Overview	7
	Incision and Exposure	8
	Intra-operative Evaluation	10
	Initial Preparation of the Tibia	11
	Preparation of the Metaphyseal Bone – Tapered Reamer	13
	Proximal Tibial Resection – Tapered Reamer	14
	Preparation of the Metaphyseal Bone – Broach	16
	Tibial Trial Assembly	18
	Joint Space Assessment	19
	Preparation of Femoral Diaphysis	20
	Reaming the Medullary Canal	21
	Preparation of the Metaphysis – Stem Use	23
	Preparation of the Metaphysis – Sleeve Use	24
	Femoral Preparation – Distal Resection	27
	Femoral Preparation – A/P and Chamfer Cuts	30
	Femoral Preparation – Notch Resection	35
	Femoral Trial Assembly	37
	Femoral Trial Assembly – Sleeve and Stem Use	39
	Femoral Trial Assembly – Stem-Only Use	41

	Femoral Trial Assembly – Sleeve-Only Use	42
	Final Preparation of the Tibia	43
	Preparation of the Patella	44
	Implant Assembly - Tibia	46
	Tibial Implantation	47
	Implant Assembly – SIGMA Femoral Adapter	48
	Implant Assembly – SIGMA Femoral Augments	50
	Implant Assembly – Sleeve and Stem Use	51
	Implant Assembly – Stem-Only Use	53
	Implant Assembly – Sleeve-Only Use	54
	Final Trial with Implants	55

APPENDICES	Key Surgical Steps Summary	4
	Appendix 1: The Cemented Tibial Stem Extensions	56
	Appendix 2: Step Wedge Preparation	59
	Appendix 3: Thick Tray Preparation	62
	Appendix 4: Femoral Revision and Tibial Insert Compatibility	63
	Appendix 5: SIGMA Revision Anteroposterior Chart (With Sleeve Use)	64
	Instrument Glossary	65

KEY SURGICAL STEPS SUMMARY

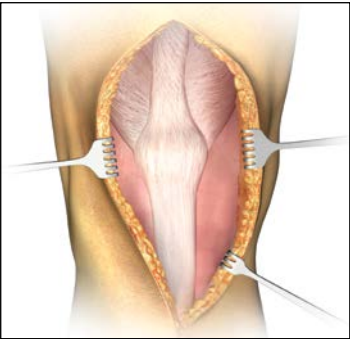

Incision and Exposure



Tibial Medullary Canal Preparation

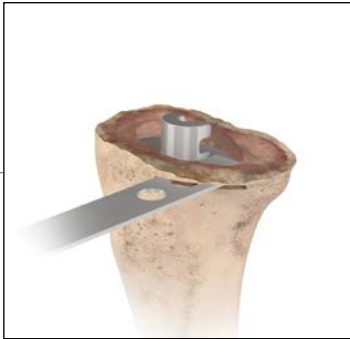

Tibial Resection



Femoral Medullary Canal Preparation

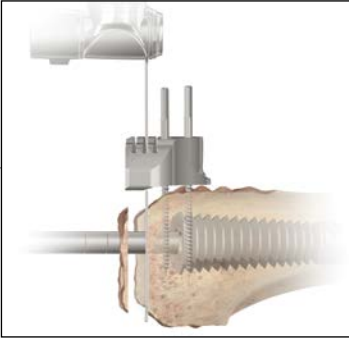

Distal Femoral Resection

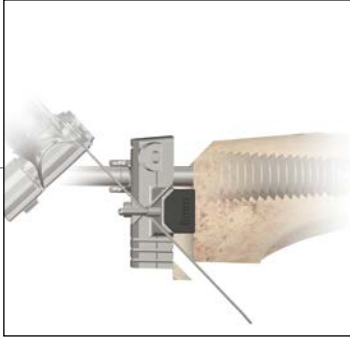

Femoral Preparation - A/P and Chamfer Cuts

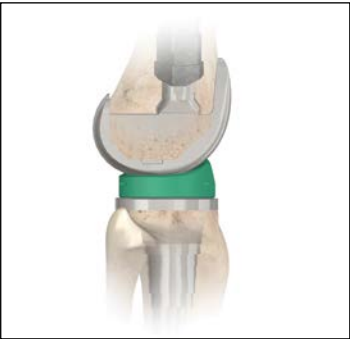

Final Trialing

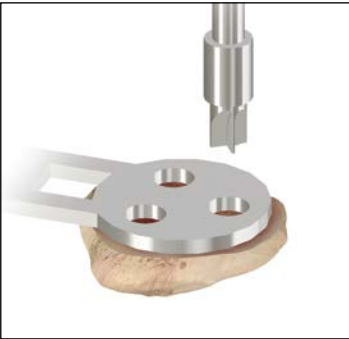

Patella Preparation



Implantation



Tibial Trial Assembly

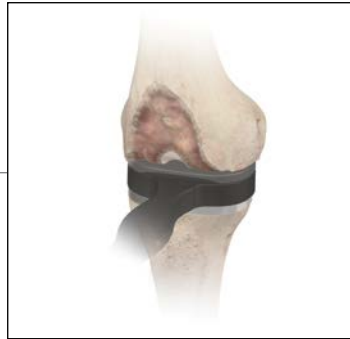

Joint Space Assessment

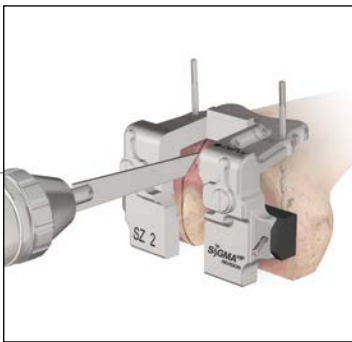

Femoral Preparation
- Notch Resection



Femoral Trial Assembly

SIGMA[®] REVISION / M.B.T. REVISION TRAY KNEE SURGERY*

Introduction

In total knee arthroplasty (TKA), failure may result from many causes including: wear, aseptic loosening, infection, osteolysis, ligamentous instability, arthrofibrosis and patellofemoral complications. In approaching revision procedures, the surgeon must address such considerations as the planning of an incision in a previously operated site, the condition of the soft tissue, mobilization of the extensor mechanism, extraction of the primary prosthesis and the attendant conservation of bone stock. Among the goals of successful revision arthroplasty are the restoration of anatomical alignment and functional stability, fixation of the revision implants and accurate re-establishment of the joint line. Careful selection of the appropriate prosthesis is of paramount importance. Ideally, the revision knee replacement system will offer the options of adjunctive stem fixation and variable stem positions, femoral and tibial augmentation, sleeve, and various levels of prosthetic constraint.

Pre-operative Planning

Revision total knee arthroplasty begins with thorough clinical and roentgenographic evaluation. Physical evaluation includes the examination of the soft tissues, taking into account previous skin incisions, range of motion, motor strength, the condition of all neurovascular structures, ligamentous stability and the integrity of the extensor mechanism. Biplanar radiographic views are obtained, as are tangential views of the patella and full-length standing bilateral extremity views for the assessment of alignment and bone stock, documentation of the joint line and evaluation of the present implant fixation. Stress views are helpful in evaluating ligamentous instability. CAT and MRI scans may at times be of value in cases of massive bone loss or substantial anatomic distortion from trauma and metabolic bone disorders. Templates are employed to establish replacement implant size and the alignment of bone cuts, to indicate augmentation of skeletal deficits and to confirm the anatomic joint line.

*The SIGMA Revision Knee System is intended for cemented use only.

THE SIGMA REVISION SYSTEM OVERVIEW

The M.B.T. Revision Knee System is comprised of the following components:

- Tibial Components are available in eight sizes
- Tibial Metaphyseal Sleeves are available in 29 mm, 37 mm, 45 mm, 53 mm and 61 mm sizes (M/L dimension)
- Tibial Wedge Augmentation Components: Step Wedge in 5, 10 and 15 mm thicknesses
- 75, 115 and 150 mm Fluted Stem lengths in 10 to 24 mm diameters in 2 mm increments
- 30 and 60 mm Cemented Stem lengths in 13 mm diameters. 90, 120, 150 Cemented Tapered Stem lengths in 13 mm diameters
- Thick Trays are available in three different sizes (2, 3 and 4) and two different thicknesses (+15 mm and +25 mm)
- Accepts Rotating Platform inserts from LCS® Complete™, SIGMA RP, LCS Complete Revision and SIGMA TC3 RP inserts
- Accepts rotating platform hinged insert, Universal LPS Hinged insert, from the Orthogenesis LPS™ (Limb Preservation System), which is compatible with the S-ROM® NOILES™ Rotating Hinge (NRH) femoral component and LPS femoral component

The SIGMA Revision Knee System is comprised of the following components:

- Stabilized Femoral Component is available in seven sizes
- TC3 Femoral Component is available in six sizes
- Modular Femoral Stem, known as the SIGMA Femoral Adapter, which allows the use of the Universal Femoral Metaphyseal Sleeves and Universal Stems. The SIGMA Femoral Adapter is available in 5 and 7 degree valgus angles
- The Universal Femoral Metaphyseal Sleeves are available in 20 mm, 31 mm, 34 mm, 40 mm and 46 mm sizes (M/L dimension), and can be used with or without a stem
- 4 mm, 8 mm, 12 mm and 16 mm Distal Femoral Augmentations
- 4 mm and 8 mm Posterior Femoral Augmentations
- Three anteroposterior stem positions: 0 mm, +2 mm and -2 mm
- 75 mm, 115 mm and 150 mm Fluted Universal Stem lengths in 10 mm to 24 mm diameters in 2 mm increments
- 30 mm and 60 mm Cemented Stem lengths in 13 mm diameter
- 30 mm and 60 mm Cemented Stem lengths in 15 mm diameter (Must be used with a sleeve)
- 90 mm, 120 mm, and 150 mm Tapered Cemented Stem lengths in 13 mm diameter
- 90 mm Tapered Cemented Stem length in 15 mm diameter (Must be used with a sleeve)

INCISION AND EXPOSURE

Initial Incision

When possible, follow the scar from the primary procedure (Figure 1). Where parallel incisions are present, the more lateral is usually preferred, as the blood supply to the extensor surface is medially dominant. Where a transverse patellectomy scar is present, the incision should transect it at 90 degrees.

Where there are multiple incision scars or substantial cutaneous damage (burn cases, skin grafting, etc.), one may wish to consult a plastic surgeon prior to surgery to design the incision, determine the efficacy of pre-operative soft tissue expansion and plan for appropriate soft tissue coverage at closure.

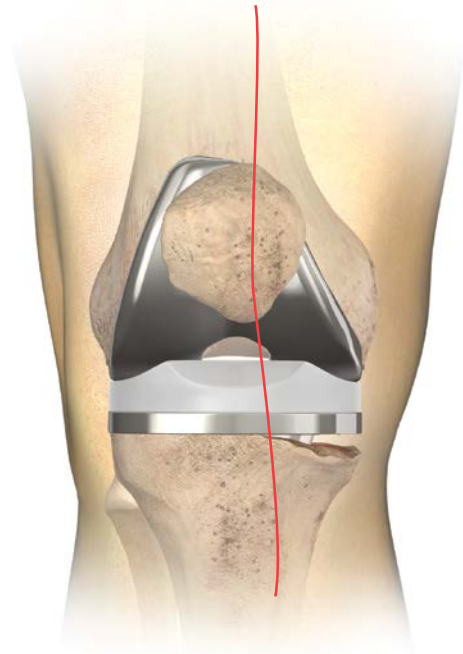

Figure 1

Capsular Incision

The fascial incision extends from the rectus femoris proximal margin to the distal margin of the tibial tubercle following the patella's medial border, maintaining a 3-4 mm cuff for reapproximation of the vastus medialis aponeurosis at closure (Figure 2). Where mobilization of the extensor mechanism and patella is problematic, extend the skin and capsular incisions proximally.

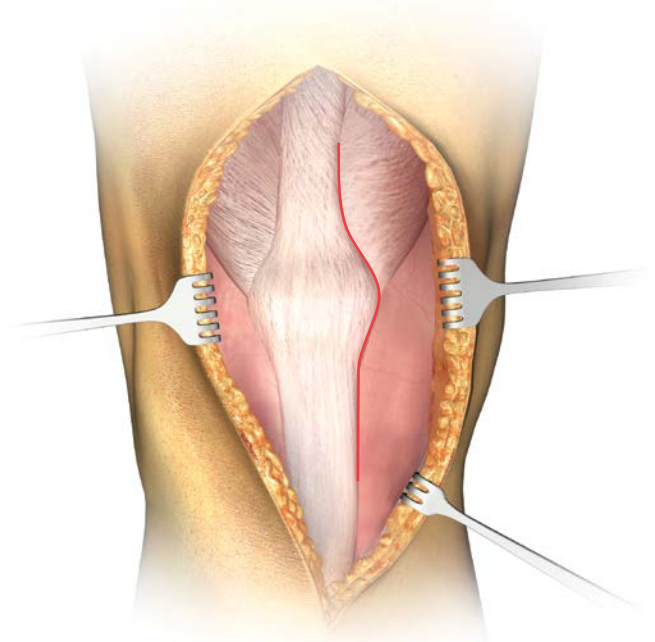

Figure 2

INCISION AND EXPOSURE

Occasionally an early retinacular release is indicated to assist with patellar eversion. Where eversion difficulties persist, a quadriceps snip, a proximal inverted quadriceps incision (modified V-Y) or a tibial-tubercle osteotomy may be indicated. Perform appropriate ligamentous release based upon pre-operative and intra-operative evaluation. Release fibrous adhesions to re-establish the suprapatellar pouch and medial and lateral gutters (Figure 3).

In many revision cases, the posterior cruciate ligament will be absent or non-functional; when this is the situation, excise any residual portion. Exercise care when everting the patella. Frequently, sublaxing the patella laterally is adequate. Doing so will help avoid patella tendon avulsion.

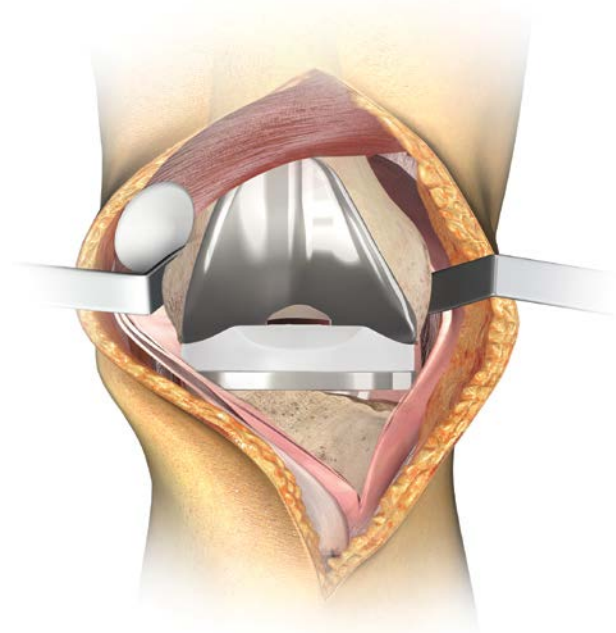

Figure 3

Implant Extraction from the Primary Procedure

Take care to preserve as much bone as possible. To this end, assemble a selection of tools, including thin Osteotomes, an Oscillating Saw, a Gigli Saw, a highspeed Burr and various extraction devices, but many cases will require only the thin Osteotome. Carefully disrupt the bone/cement or bone prosthesis interface before attempting extraction (Figure 4).

Disengage the implanted components and extract as gently as possible, in such manner as to avoid fracture and unnecessary sacrifice of bone stock. Where the entire prosthesis is to be replaced, it is advantageous to remove the femoral component first, as this will enhance access to the proximal tibia. Clear all residual methyl methacrylate with hand (chisels) or power tools.



Figure 4

INTRA-OPERATIVE EVALUATION

The surgeon should establish two anatomic conditions to facilitate revision arthroplasty: the level of the joint line and the disparity in the flexion and extension gaps (Figure 5).

Joint Line Evaluation

In an average knee in full extension, the true joint line can be approximated in reference to several landmarks.

- It lies 12–16 mm distal to the femoral PCL attachment
- It lies approximately 3 cm distal to the medial epicondyle and 2.5 cm distal to the lateral epicondyle
- It lies distal to the inferior pole of the patella (approximately one finger width)
- Level with the old meniscal scar, if available

Additional pre-operative joint line assessment tools include:

- 1) Review of original pre-operative radiograph of the TKA
- 2) Review of radiograph of contralateral knee if non-implanted

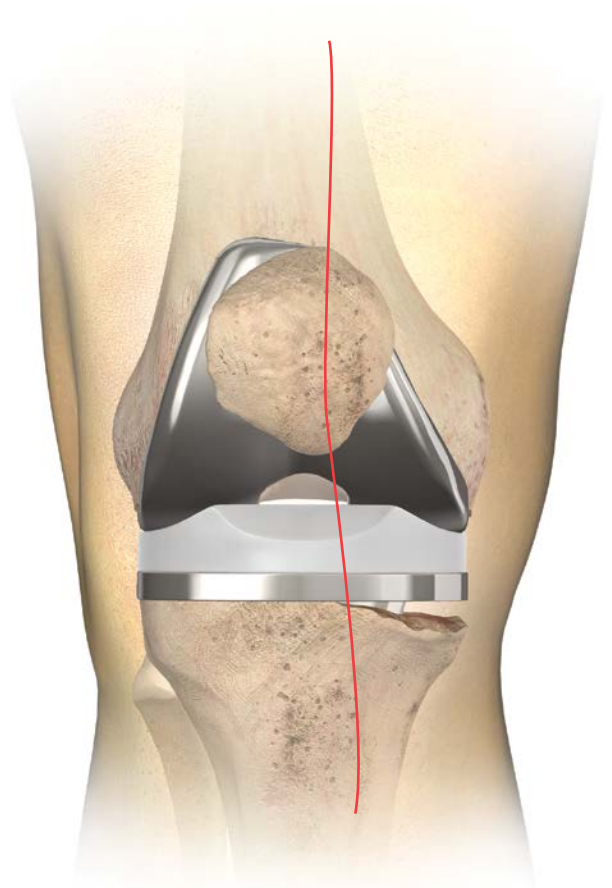

Figure 5

INITIAL PREPARATION OF THE TIBIA

The Tibial Alignment System

When pre-operative evaluation and radiographs indicate that fluted stem extensions, metaphyseal sleeves or Wedges are required, it is recommended that the proximal tibia be prepared with reference to the position of the IM Rod.

Note: Where a Cemented Stem Extension is indicated, see Appendix 1 (page 56).

Place the knee in maximal flexion with the patella laterally retracted and the tibia distracted anteriorly and stabilized. Release fibrosis around the tibial border or excise as required to ensure complete visualization of its periphery.

Approximate the location of the medullary canal with reference to pre-operative anterior/posterior (A/P) and lateral radiographs and to the medial third of the tibial tubercle.

Introduce a 9 mm Drill into the canal to a depth of 2 to 4 cm. Avoid cortical contact (Figures 6 and 7).

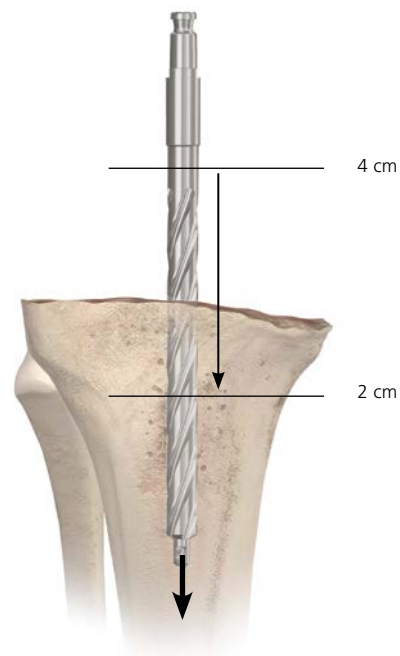

Figure 6

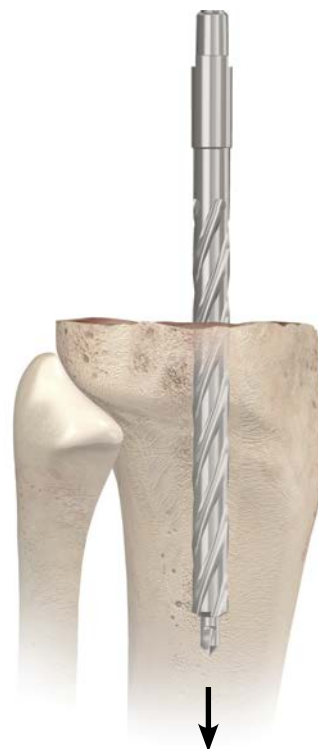

Figure 7

INITIAL PREPARATION OF THE TIBIA

Reaming the Medullary Canal

Assemble the straight reamer to the T-handle. If power reaming, it will be necessary to attach the modified Hudson Adapter to the straight reamer. The shaft of the Reamer contains markings in 25.4 mm (1 inch) increments. Each marking is numbered to use as a reference when reaming to the appropriate depth. Fluted stem lengths are available in 75, 115 and 150 mm. Determine the length and diameter of the Prosthetic Stem Extension with Templates (Cat. No. 2178-30-100) applied to pre-operative Radiographs.

Use the Reamer Depth Chart (Figure 8) to determine the appropriate mark on the reamer for canal reaming depth. Another option to determine Reamer depth is to measure the trial assembly against the Reamer and note the corresponding depth mark for reaming. Sequentially open the canal with progressively larger Reamers until firm endosteal engagement is established (Figure 9).

Note: Simple cortical contact should not be construed as engagement.

The fixed relationship of the reamer to the cortices ensures the secure fit of the appropriate reamer and, subsequently, the corresponding fluted stem. It is equally important to not over-ream osteopenic bone. While reaming the proximal tibia, pay close attention to the reamer to assure that it is somewhat centrally located to the exposed proximal tibial surface. Eccentric reaming can occur, which could lead to undersizing of the tibial component.

The size of the final reamer indicates the diameter of the implant stem. The fluted stems are available in even sizes (10 through 24 mm). Perform final reaming with an even-sized reamer. The final implant will have a .4 mm press fit versus the reamer.

Note: Refer to Appendix 1 (page 56) for cemented stem preparation.

Reamer Depth Chart

M.B.T. Revision Tray		Reamer Line Depth
Press Fit Stems	75 mm	2
	115 mm	3
	150 mm	4
Cemented Stems	30 mm	1
	60 mm	2
	90 mm	2.5
	120 mm	3.5
	150 mm	4

Figure 8



Figure 9

PREPARATION OF THE METAPHYSEAL BONE – TAPERED REAMER

For Diaphyseal Engaging Stem and Metaphyseal Filling Sleeve

Attach the appropriately sized stem trial to the end of the M.B.T. Revision Tapered Reamer.

Note: Assembly of the stem trial may be aided by the pre-attachment of the T-handle to the M.B.T. Revision Tapered Reamer.

Taper ream to the planned proximal tibial resection level (Figure 10). When finished reaming, the notches on the drill should line up with the planned proximal tibial resection level.

Note: Use the “cemented” taper reamer when requiring a cement mantle or when utilizing a sleeve. Use the press-fit tapered reamer when line-to-line fit is desired and a sleeve will not be utilized (Figure 10). Use End-Cutting Primary Reamer (Cat. No. 2178-63-199) when a stem or sleeve will not be used.

Note: To avoid stem trial disengagement, do not reverse ream.

At this point, intra-operatively determine if a metaphyseal sleeve will be used.

Note: Metaphyseal sleeves are ideal to provide filling of Engh Type II or III defects in revision TKA. The steps of the metaphyseal sleeve also provide progressive loading of the bone with porous coating, which enhances fixation.

If a metaphyseal sleeve is selected, see page 16 in order to broach the metaphyseal bone.

If a metaphyseal sleeve will not be used, see the following page to prepare for the proximal tibial resection.

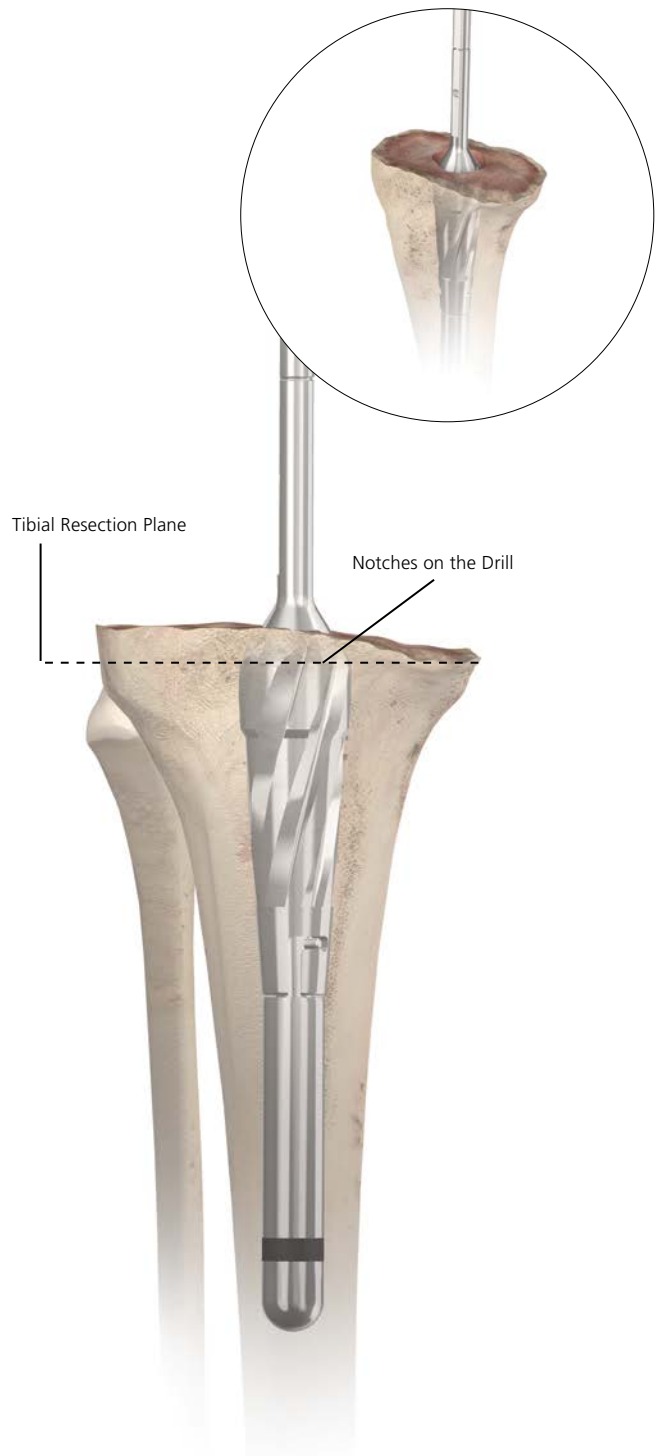

Figure 10

PROXIMAL TIBIAL RESECTION – TAPERED REAMER

Attach the 2 degree Tibial Cutting Block to the I.M. Tibial Referencing Device. Attach the I.M. Tibial Referencing Device to the shaft of the tapered reamer. Position the I.M. Tibial Referencing Device with the pre-attached 2 Degree Cutting Block onto the shaft and allow it to descend to the proximal tibial surface. Since considerable bone stock may have been sacrificed in the primary total knee arthroplasty, minimize the amount resected: no more than 1-2 mm from the most prominent condyle, managing residual defects of the contralateral condyle with either prosthetic augment or bone graft.

Resection is based on tibial deficiency and the level of the joint line. Compensate deficiencies with sleeves, wedges and/or bone grafts. Advance the cutting block to the anterior tibial cortex and lock into position by tightening the knurled knob on the outrigger. Preliminary rotational alignment is based on the medial third of the tibial tubercle. Secure the alignment device to the reamer shaft with the lateral Setscrew (Figure 11).

Pin the Tibial Cutting Block so a minimal resection is made from the proximal tibia. Utilize the stylus when necessary (Figure 11).

Note: There is a slotted and non-slotted end to the stylus. The difference between the two is 5 mm.

Note: If a metaphyseal sleeve is to be used the tibial resection will be performed using the Tibial Sleeve Broach (see page 17, Figure 14).

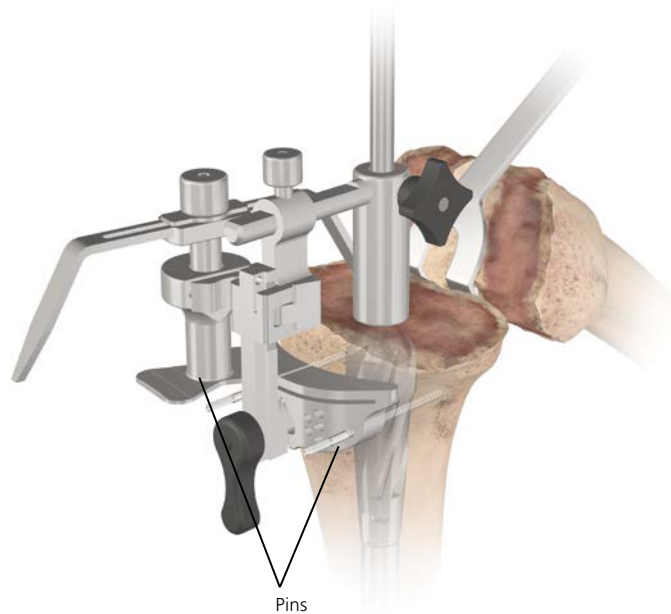

Figure 11

PROXIMAL TIBIAL RESECTION – TAPERED REAMER

Remove the I.M. device while leaving the 2 degree Cutting Block in place. Remove the tapered reamer and resect the proximal tibia (Figure 12).

Note: At this point determine whether a Step Wedge is necessary on either the medial or lateral side to augment a defect, or both sides in order to restore the joint line. If a wedge is necessary on one side, it is recommended that the step wedge be prepared after rotational position of both the femoral and tibial components have been determined. For step wedge preparation see Appendix 2 (page 59).

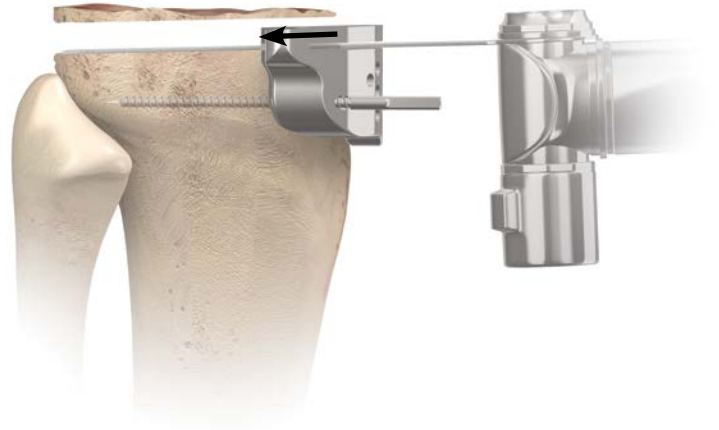

Figure 12

PREPARATION OF THE METAPHYSEAL BONE – BROACH

For Sleeve Utilization Only

Note: The M.B.T. Revision Tibial Tray will accept either a tibial metaphyseal sleeve or a tibial step wedge. Only the 29 mm Sleeve is indicated for use with a tibial step wedge.

Attach the M.B.T. Revision Broach Handle to the smallest broach and then attach the appropriately sized Stem Trial. The broaches are asymmetrical, position the “ANT” engraving on the broach anteriorly. Impact the broach into the tibia until the top surface of the broach is at the desired proximal tibial resection level. When broaching the proximal metaphysis, take care to assure the appropriate rotation of the broach.

Note: The corresponding tibial sleeve implant allows up to +/- 20 degrees of rotation from the centerline of the M.B.T. Revision Tray.

Check for rotational stability of the broach. If the broach (not the handle) moves in the canal, it is not rotationally stable.

If the broach is unstable or the defect is unfilled, repeat with consecutively larger broaches until the desired fit is achieved (Figure 13). Remove the broach handle, leaving the last broach in place. Any defects remaining can be filled with allograft or autologous bone placed in intimate contact with the sleeve.

Two common tibial broaching techniques:

- 1) Chase the defect by rotating the broach to fill the defect until reaching rotational stability of the broach. If utilizing this technique the surgeon must be aware that the sleeves are allowed to rotate +/-20 degrees with respect to the M.B.T. Revision Tibial Tray.
- 2) Align the broach with the medial third of the tibial tubercle and progressively broach until rotational stability of the broach is attained.

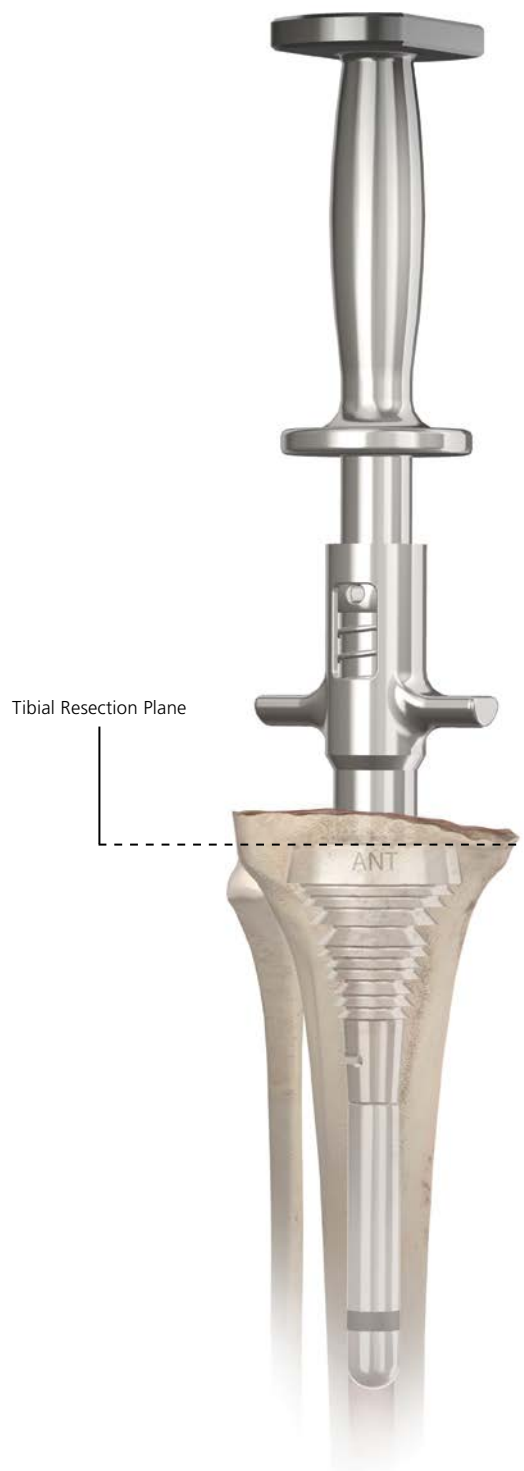

Figure 13

PREPARATION OF THE METAPHYSEAL BONE – BROACH

Resect the proximal tibia utilizing the top of the broach as a guide (Figure 14). The top of the broach has a 2 degree slope built in. The proximal cut should be parallel to the top of the broach.

Note: If a cutting guide is desired for resecting the proximal tibia with the tibial broach in place, assemble the SP2 0 degree Tibial Cutting Block to the SP2 IM Tibial Guide and slide over the Broach Adapter Outrigger (2178-01-108). Slide this assembly onto the boss of the seated tibial broach, pin the block, remove the outrigger, and resect through the slot of the cutting block (Figure 15).

Slide the tibial view plate which best covers the proximal tibia over the broach post. Note the view plate size as it will dictate the size of the M.B.T. Revision Tibial Base Trial that will be used. The tibial view plate is transparent to help visualize tibial coverage (Figure 16). The template matches the implant to aid in orienting the tibial sleeve to the tibial base during assembly.



Figure 14



Figure 15



Figure 16

TIBIAL TRIAL ASSEMBLY

Assemble the tibial tray trial with the stem extension and sleeve trial, if applicable (Figure 17). Position the tibial trial construct into the prepared tibial canal (Figure 18). Assess proximal tibial coverage and rotation of tibial component. The base plate should be positioned to provide the best coverage of the tibial condylar surface.

Note: The M.B.T. Revision Tibial Keel Punch with the Universal Handle may be utilized to assist with seating of tibial trial construct. Once the tibial trial construct is seated the keel punch must be removed in order to accommodate the use of the HP Revision M.B.T. Spacer Blocks.

Leave the trial in place and proceed to femoral preparation, final tibial preparation will occur after femoral preparation is complete.

Note: A 14 mm or smaller size stem implant can be pulled through the sleeve implant. If the stem is 16 mm or greater it will not pull through the sleeve.

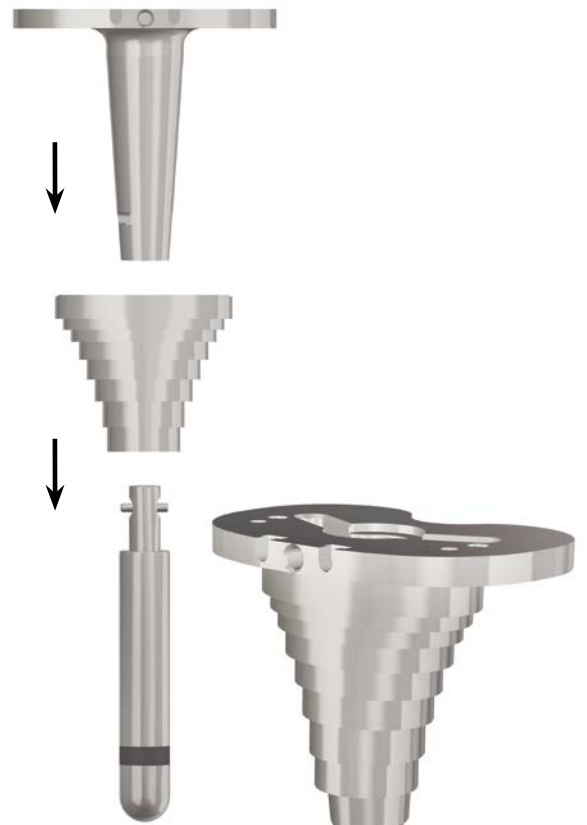

Figure 17



Figure 18

JOINT SPACE ASSESSMENT

After tibial preparation has been performed you may utilize the HP Revision M.B.T. Spacer Blocks to assess the flexion and extension gaps (Figures 19 and 20). For common scenarios, potential solutions are explained below.

Where flexion gap > extension gap:

- To decrease flexion gap without affecting extension gap, apply a larger femoral component. This is particularly important where an IM Stem Extension is indicated, as the Stem Extension will determine the anteroposterior positioning of the component and the consequent flexion gap
- Where stem positioning will not permit posterior augmentation, translate the Femoral Adapter Trial on the TC3 Box Trial to the +2 (Fem Pos) position. This will result in translating the femoral component 2 mm posteriorly (Refer to page 38 for further explanation)
- Where there is insufficient stability, a cemented femoral stem may be substituted, allowing the component to be seated further posteriorly
- Where the joint line is elevated, the preferred correction is posterior femoral augmentation. The alternative—additional distal femoral resection and use of a thicker tibial insert to tighten the flexion gap—is not recommended, as considerable bone stock has been sacrificed in the primary procedure, and it is important that additional resection of the distal femur be avoided. The possible exception is where the joint line is not elevated and minimal distal resection will increase the extension gap toward equivalency with the flexion gap



Figure 19

Figure 20

JOINT SPACE ASSESSMENT

Where extension gap > flexion gap:

- To decrease extension gap without affecting flexion gap, augment the distal femur with bone graft or prosthetic augmentation. It is important to note that this will lower the joint line, which is usually desirable as it is generally found to be elevated in revision cases. This will lessen the incidence of post-operative patella infera

Note: In the initial assessments of the joint space the Extension Shim may be utilized to help evaluate the flexion space. This will only be used to evaluate gap differences. It is important to keep in mind that the use of the Extension Shim in flexion will be approximately 1 mm thicker than the final flexion gap. If the Extension Shim is not used here to evaluate flexion, the Spacer Block will be approximately 4 mm thinner than the final flexion gap.

Flexion/Extension Balancing

	Loose Extension	Tight Extension	Stable Extension
Loose Flexion	<p>Cause Flexion and extension gaps are too large.</p> <p>Possible Solution Thicker tibial insert.</p>	<p>Cause Inadequate resection of the distal femur (i.e. extension gap < flexion gap).</p> <p>Possible Solution 1. Recut distal femur. 2. Recut chamfers.</p>	<p>Cause Extension gap < flexion gap. Can be tolerated to a small extent, but verify stability.</p> <p>Possible Solution 1. Increase tibial bearing thickness and reset more distal femur. 2. Upsize femoral component.</p>
Tight Flexion	<p>Cause 1. Extension gap > flexion gap. 2. Posterior osteophytes.</p> <p>Possible Solution 1. Check for presence of posterior femoral osteophytes. 2. Downsize femoral component. 3. Cut Posterior slope on the tibia (not to exceed 10 degrees) and increase tibial bearing thickness.</p>	<p>Cause Flexion and extension gaps are too small.</p> <p>Possible Solution 1. Thinner tibial component. 2. If the smallest PE is still too tight, resect more tibia.</p>	<p>Cause Flexion gap is too small.</p> <p>Possible Solution 1. Check for posterior femoral osteophytes. 2. Ensure that there is no soft tissue impingement. 3. Recut the tibia with a posterior slope. 4. Possibly downsize femoral component.</p>
	<p>Cause 1. Extension gap > flexion gap.</p> <p>Possible Solution Upsize the tibial components. Might be necessary to recut tibia with bigger posterior slope (not to exceed 10 degrees) to obtain full range of motion (ROM).</p>	<p>Cause Extension gaps are too small.</p> <p>Possible Solution Recut the distal femur and chamfers.</p>	<p>Cause Excellent ligament balance.</p> <p>Possible Solution You have already found it.</p>

PREPARATION OF FEMORAL DIAPHYSIS

Intramedullary Femoral Alignment System

This technique is designed to flow in a logical sequence, from reaming the diaphysis, to broaching the metaphysis and cutting the bone. The length and diameter of the stem extension is determined with templates applied to pre-operative radiographs.

Begin the procedure with the preparation of the medullary canal (Figures 21 and 22).

Enter the medullary canal with a 9 mm Drill to a depth of 3-5 cm (Figure 23). Take care that the drill avoids the cortices. It is helpful to palpate the distal femoral shaft as the drill is advanced.

Where impedance of the intramedullary canal is anticipated, adjust the entry point accordingly.



Figure 21

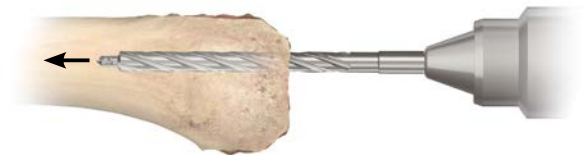

Figure 22

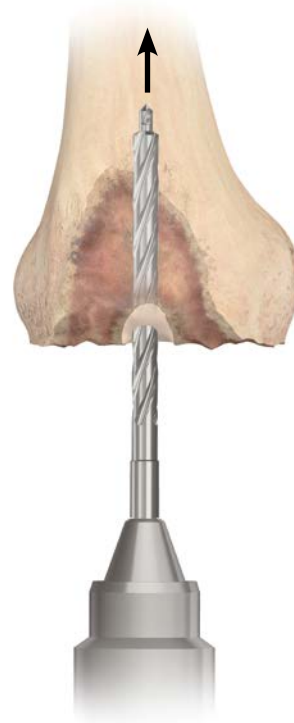

Figure 23

REAMING THE MEDULLARY CANAL

Connect the Reamer Handle to a small diameter M.B.T. Revision Reamer. If power reaming, it will be necessary to attach the modified Hudson Adapter to the Straight Reamer.

Note: The Reamer shaft contains markings in 25.4 mm increments to accommodate the various Universal stem/sleeve length combinations (Figure 24).

Use the Reamer Depth Chart (Figure 25) to determine reamer depth for each combination of components. Another option to determine reamer depth is to measure the trial assembly against the reamer and note the corresponding depth mark for reaming.

You may also determine the length and diameter of the prosthetic stem extension with templates (Cat. No. 2294-99-035: SIGMA Femoral Adapter Sleeve and Stem Template) applied to pre-operative Radiographs.

The P.F.C.® SIGMA Femoral Component accepts:

- Universal Fluted Stems available in lengths of 75, 115 and 150 mm in diameters of 10-24 mm
- Cemented Stems available in lengths of 30 and 60 mm lengths and diameters of 13 and 15 mm (15 mm with sleeve use only)
- Cemented Tapered Stems available in lengths of 90, 120, 150 mm (13 mm diameter) and also a 90 mm in 15 mm diameter (with sleeve use only)

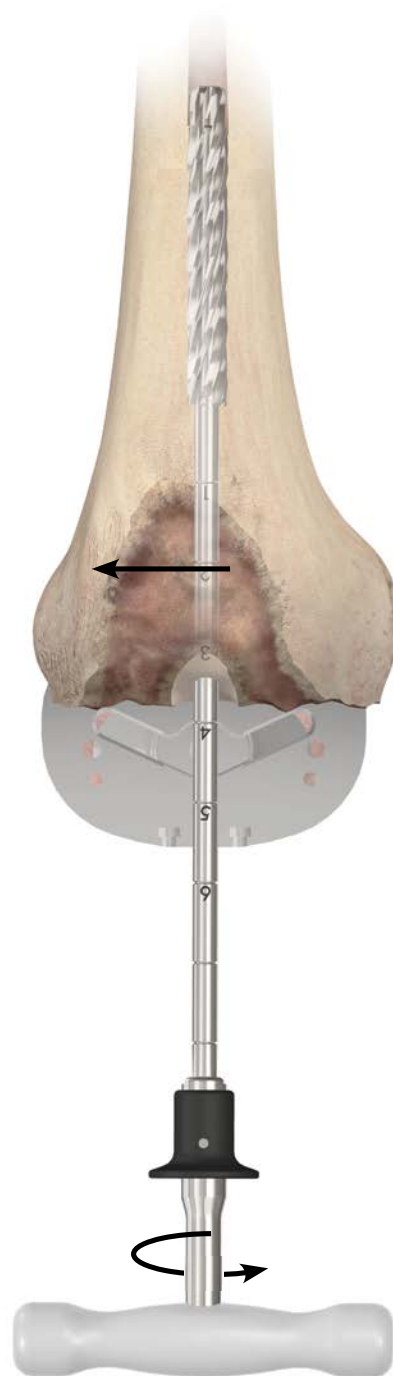

Figure 24

REAMING THE MEDULLARY CANAL

In 1 mm diameter increments, sequentially open the medullary canal with M.B.T. Revision Reamers of progressively greater size until firm endosteal engagement is established.

Take care to ream the canal in line with the femoral axis to avoid putting the implant in flexion.

Note: Do not reverse ream.

It is important that simple cortical contact of the tip not be construed as engagement as it is the fixed relationship of the reamer to the cortices that ensures the secure fit of the appropriate sleeve and subsequently, the corresponding fluted or cemented stem.

PS Femur		No Sleeve	20 mm 31 mm 34 mm	40 mm 46 mm
Cemented Stems	30 mm	1	2	2
	60 mm	2	3	3
	90 mm	4	5	5
	120 mm	4	6	6
	150 mm	5	7	7
Universal Slotted Stems	75 mm	2	4	4
	115 mm	4	5	6
	150 mm	5	7	7

TC3 Femur		No Sleeve	20 mm 31 mm 34 mm	40 mm 46 mm
Cemented Stems	30 mm	1	2	2
	60 mm	2	3	4
	90 mm	4	5	5
	120 mm	4	6	6
	150 mm	6	7	7
Universal Slotted Stems	75 mm	3	4	4
	115 mm	4	5	6
	150 mm	6	7	7

Figure 25

PREPARATION OF THE METAPHYSIS – STEM USE

Universal Fluted Stem Use:

As Fluted Stems are available in even sizes (10 through 24 mm diameters), perform final reaming with the appropriate even-sized reamer.

Note: For stem-only applications, where a Fluted Stem less than 16 mm in diameter is chosen, use the Stem Reamer to clear the area around the adapter.

Attach the threaded shaft to the Stem Reamer and then attach the appropriate Stem Trial to this assembly (Figure 26). Ream the canal (Figure 27).

Sink the Threaded Shaft, Stem Reamer, Stem Trial assembly until the 20 mm, 31 mm, 34 mm mark corresponds with the planned level of distal resection.

For trial and implant assembly with stem-only use, please see page 41.

Cemented Stem Use:

Where a Cemented Stem Extension is indicated, perform final reaming with a 15 mm Diameter Reamer for the 13 mm diameter stem extension; similarly, a 17 mm Diameter Reamer is used to accommodate the 15 mm diameter stem extension. This allows for creation of a cement mantle.

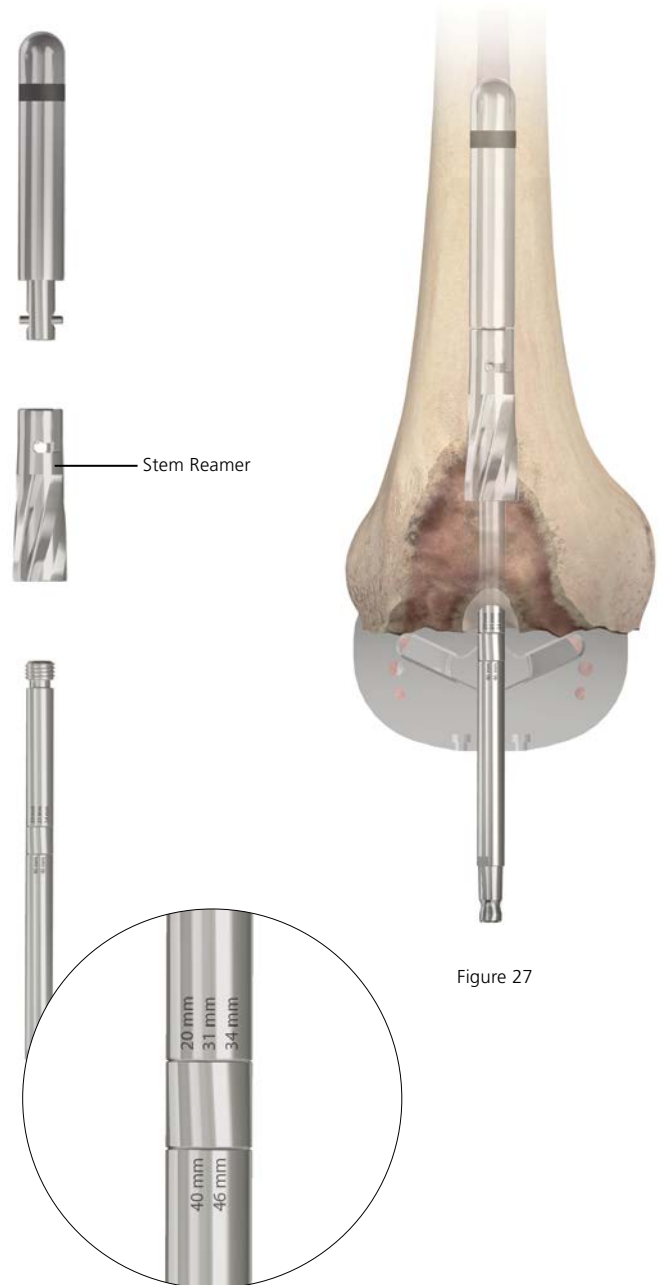

Figure 26

Figure 27

PREPARATION OF THE METAPHYSIS – SLEEVE USE

After reaming the intramedullary canal, attach the threaded shaft to the broach reamer and then to the appropriate Stem Trial as determined by straight reaming (Figure 28).

Ream to the 20 mm, 31 mm, 34 mm etch mark on the Threaded Shaft (Figure 29).

When using the broach reamer, the next smaller diameter stem trial may be used to allow for easier reaming. The broach reamer will be necessary when utilizing a 20 mm Sleeve and for the beginning of larger sequential broaching when using a 31 mm or larger sleeve. After broach reaming has been completed, attach the 31 mm broach to the broach handle (Figure 30). Attach the appropriate stem trial to the broach as determined by straight reaming. Give close attention to the medial orientation of the broach.

Note: The broach is asymmetrical; and the narrow side of the broach must point medially (Figure 31).

Note: When prepping for a 20 mm Sleeve, leave the broach reamer and threaded shaft in the canal and perform the subsequent femoral cuts off the reamer.

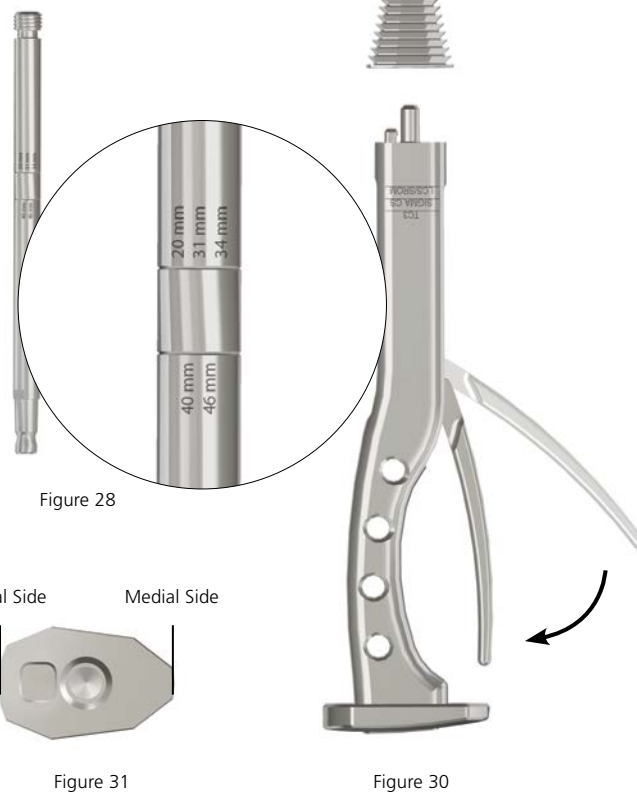
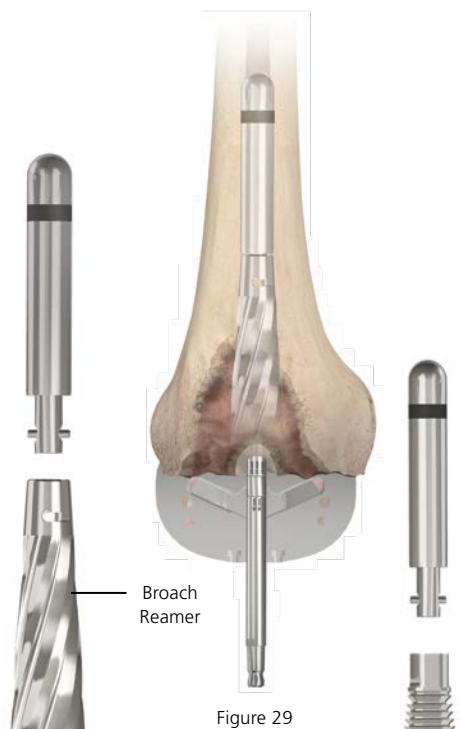

PREPARATION OF THE METAPHYSIS – SLEEVE USE

Sequentially broach to the desired TC3 or SIGMA CS Line (Figure 32). When the appropriate etch mark on the broach handle is at the planned distal resection level, check the broach's rotational stability. If the broach (not the handle) moves in the canal, it is not rotationally stable.

If the stability of the broach is unsatisfactory, move up to the next broach size. The last broach used will be the femoral sleeve size. The broach depth sets the extension gap/joint line.

In patients with a large degree of distal femoral bow, closely monitor the anterior progression of the broach during impaction. Excessive anterior placement of the broach may result in a loose flexion gap.

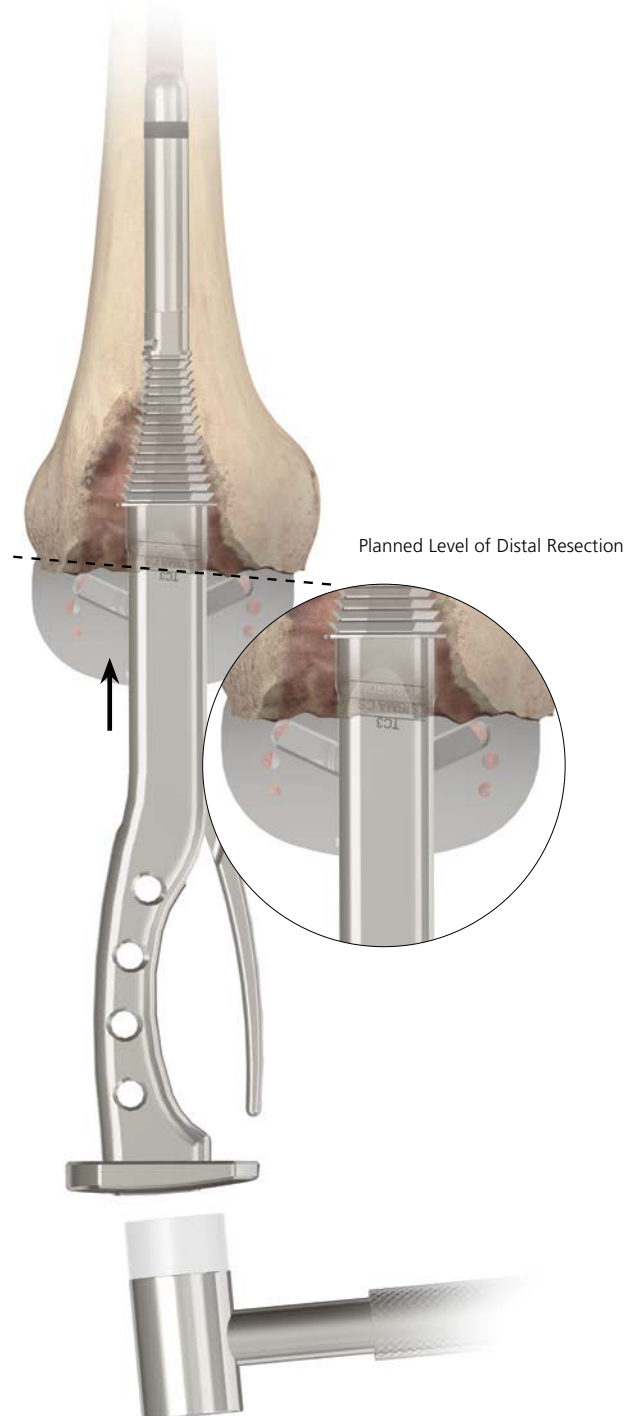

Figure 32

PREPARATION OF THE METAPHYSIS – SLEEVE USE

After broaching is complete, remove the broach handle from the broach. With the broach seated in the femur, attach the threaded shaft to the broach (Figure 33), and continue with the distal, 4-in-1, and notch cuts.

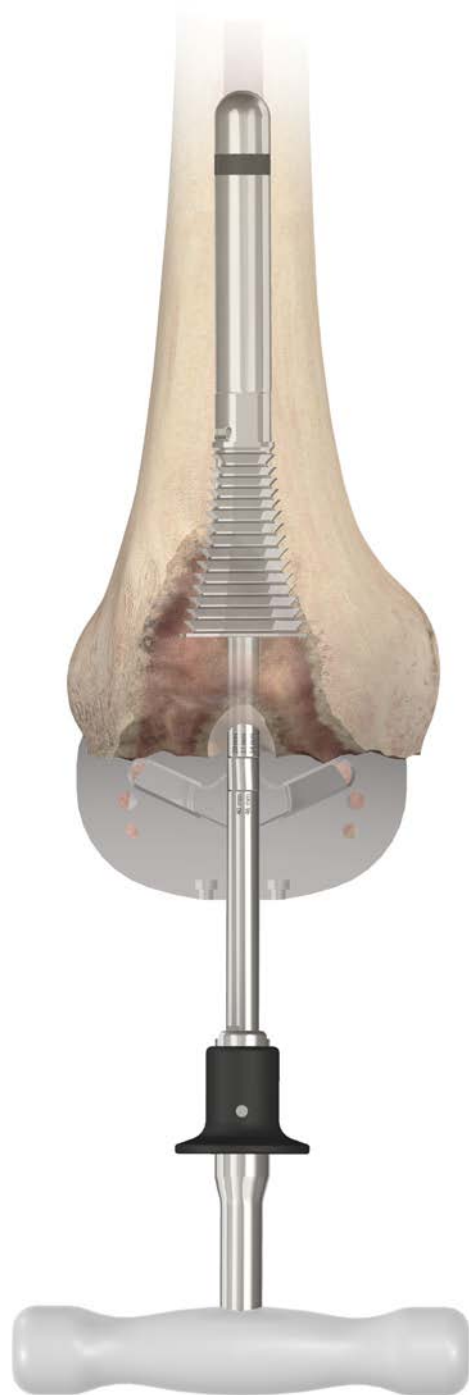

Figure 33

FEMORAL PREPARATION – DISTAL RESECTION

Distal Resection

Set the valgus angle to 5 degrees and Left/Right on the Distal Femoral Alignment Guide by compressing the two triggers and lock in place by rotating the blue locking lever clockwise. Place the Femoral Alignment Guide on the threaded shaft and seat against the distal femur (Figure 34).

Rotate the knob on the Femoral Resection Guide counterclockwise until the arrow is pointing to the padlock symbol. Slide the femoral distal connector into the Femoral Resection Guide. Rotate the knob on the Femoral Resection Guide clockwise. Every click moves the Revision Distal Cutting Block 1 mm proximal or distal. Turn the knob clockwise from 15 all the way down to 0 (which is the padlock symbol). This will set the block up for a 0 mm resection (Figure 35).

Slide the femoral Distal Cutting Block onto the Distal Femoral Block attachment. The tang on the block connector will slide into the 0 mm cutting slot on the cutting block. The trigger should engage in the hole behind the 0 mm slot (Figure 36).

Note: An open resection will resect 4 mm less femur. When a 0 mm, open resection is desired, the dial should be set to 4 mm.

Position the Resection Guide over the two legs of the Distal Femoral Alignment Guide until the Distal Cutting Block touches the anterior femur (Figure 37).

Note: The Revision Distal Block is equipped with 0, 4, and 8 mm saw slots. Please keep in mind that if the resection level is not at 0 (the padlock symbol) this will alter the resection. If the resection knob is set at 2, for instance, the saw slots will perform 2, 6, and 10 mm resections.

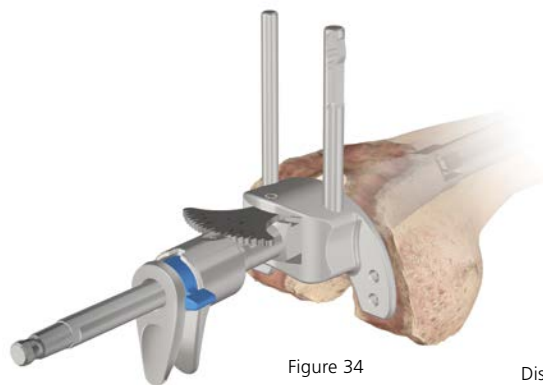

Figure 34

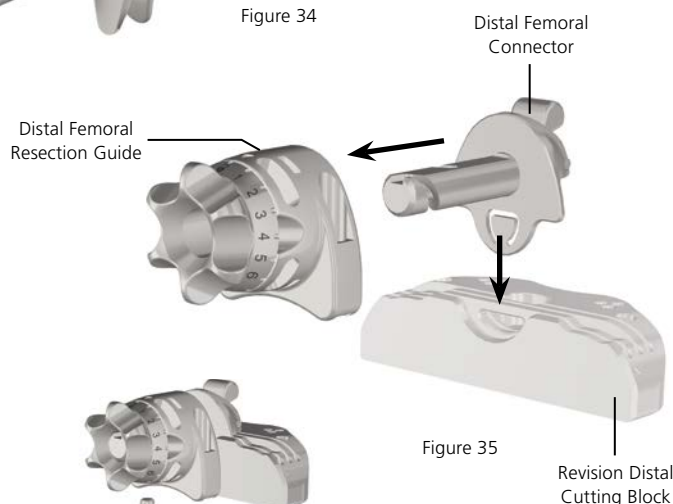

Figure 35

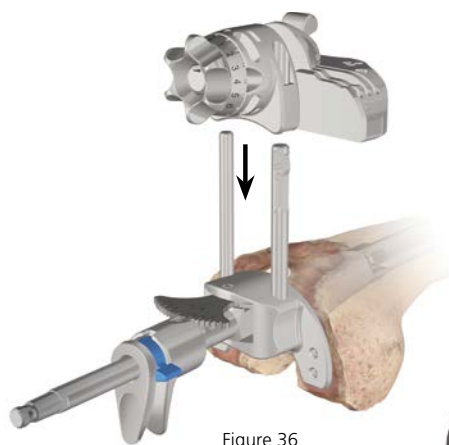

Figure 36

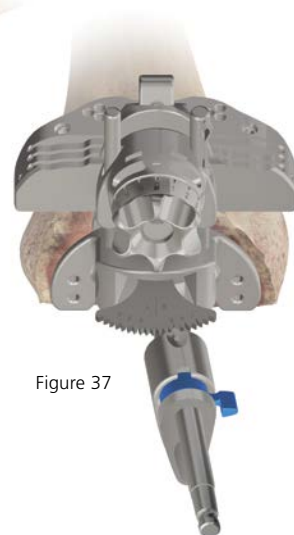

Figure 37

FEMORAL PREPARATION – DISTAL RESECTION

Secure the cutting block to the femur with Non-Headed HP Pins through the holes marked with a .
Optional: A Convergent Pin can also be used to provide better block stability/fixation (Figures 38 and 39).

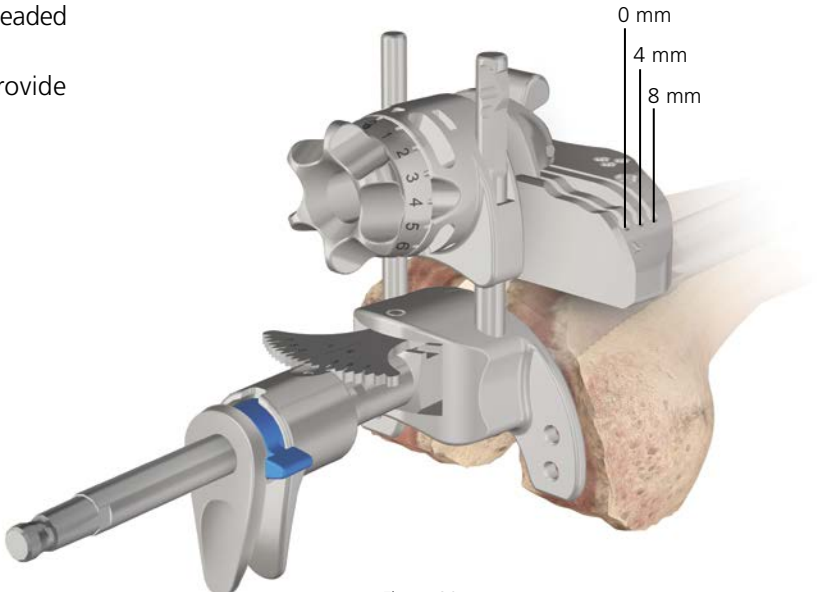

Figure 38

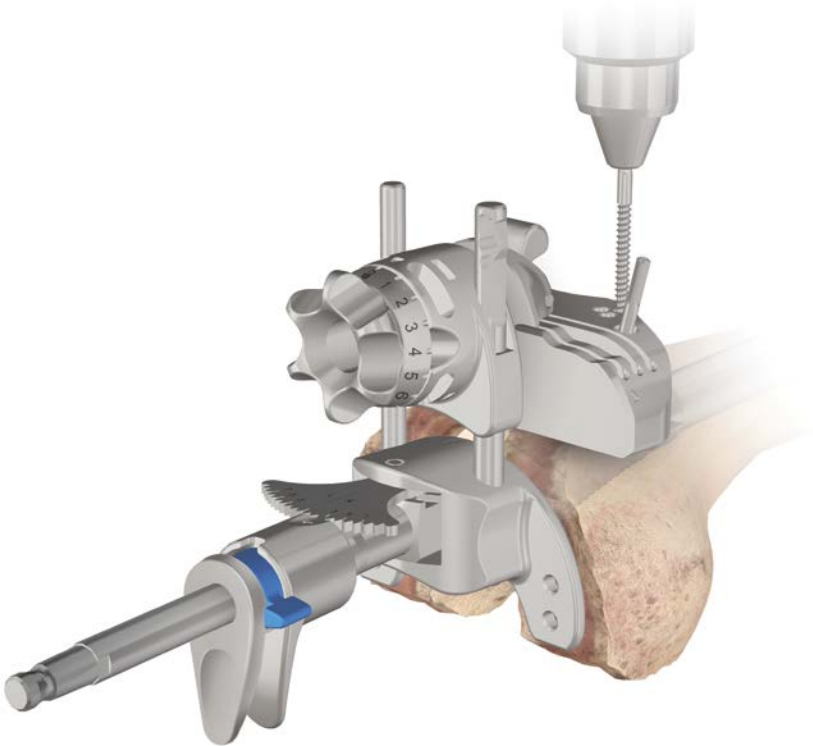

Figure 39

FEMORAL PREPARATION – DISTAL RESECTION

Once the pins are in place, unlock the Distal Cutting Block from the distal block connector, using your thumb and index finger to release the attachment. Slide the Femoral Resection Guide upwards on the Alignment Guide legs until the block connector disengages from the cutting block and in one motion remove the Femoral Alignment Guide by pulling the instruments distally over the threaded shaft (Figure 40).

In many cases, little, if any, bone is removed from the distal femur as the joint line is effectively elevated with the removal of the primary femoral component. As the level of resection is based on the preservation of bone stock, each condyle is cut only to the level required to establish a viable surface, with augmentation employed to correct imbalance

The resection is then performed through the slot appropriate for each condyle, using a standard 1.19 mm Thick Blade (Figure 41).

Note: If a ½ inch wide Standard Saw Blade is used it can complete both medial and lateral distal femoral cuts with the entire jig still in place.

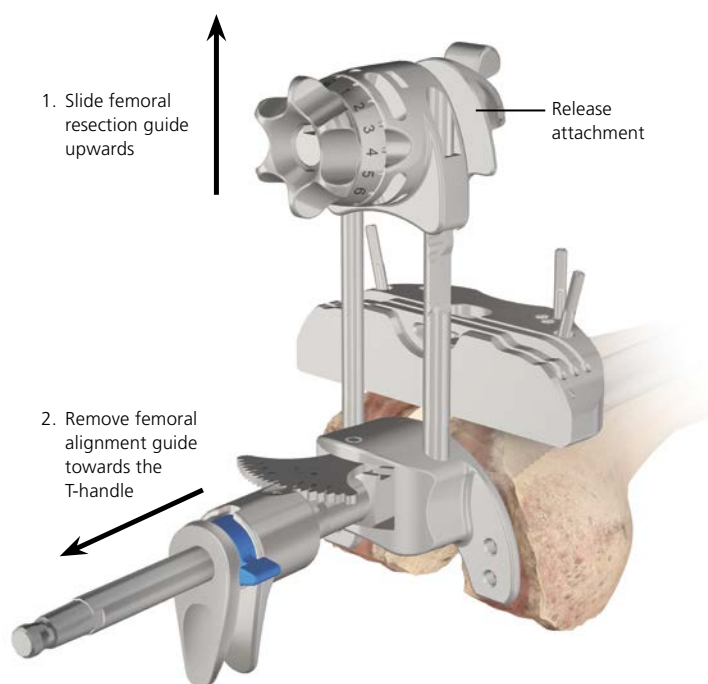

Figure 40

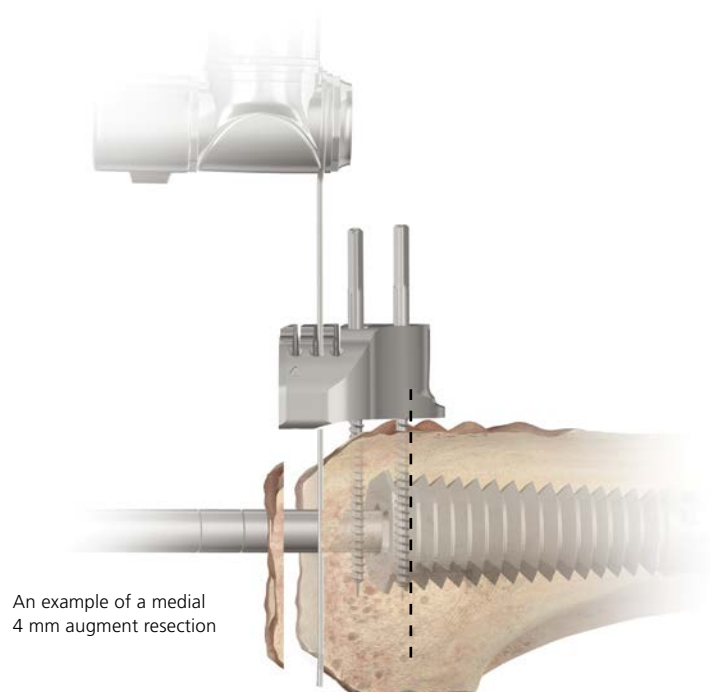

Figure 41

FEMORAL PREPARATION – A/P AND CHAMFER CUTS

To size the femur, turn the femoral trial around so the posterior condyles point away from the distal surface (Figure 42). The M/L width of the trial should provide the femoral size. Once the femoral size is determined, select the appropriately sized Revision 4-in-1 Cutting Block.

Note: The Revision 4-in-1 Cutting Blocks may also be used to assess the femoral size, as the block is the same M/L width as the implant (See Figure 43).

If augment cuts were made during the distal resection, assemble the appropriate distal spacer (4, 8, 12 or 16 mm) to the proximal side of the cutting block to compensate for the condylar discrepancy. The distal spacers slide in from the side using a dovetail connection on the 4-in-1 Block (Figure 44).

Each distal spacer thickness is represented by a different color (Figure 45).

Red = 4 mm

Black = 8 mm

Green = 12 mm

Blue = 16 mm

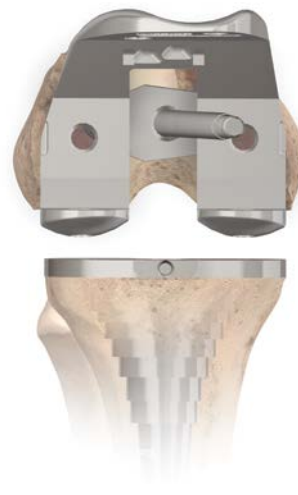

Figure 42

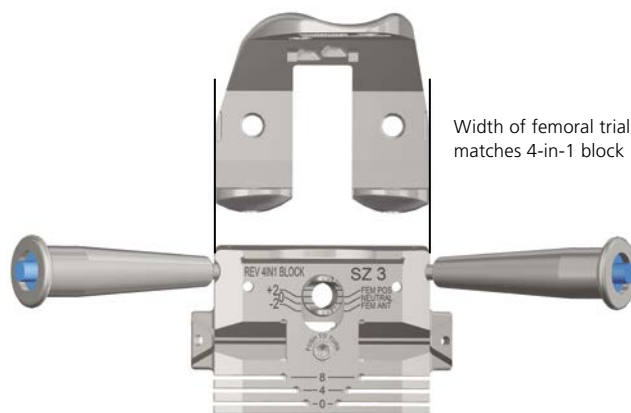

Figure 43

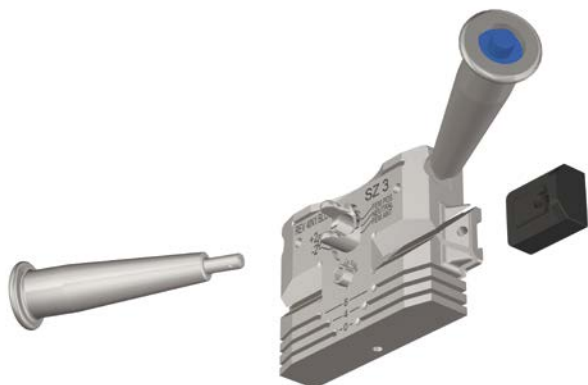

Figure 44

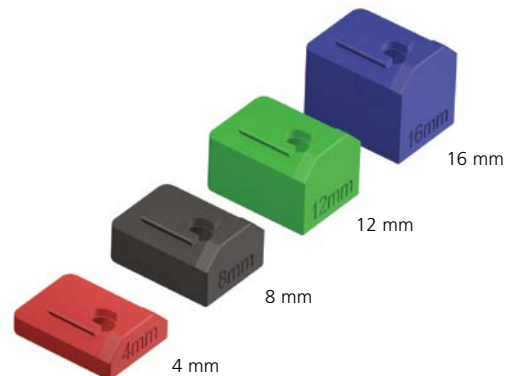

Figure 45

FEMORAL PREPARATION – A/P AND CHAMFER CUTS

The HP Revision 4-in-1 Cutting Block is fixed at a 5 degree angle. To change the block's orientation for left 5 degrees or right 5 degrees, flip over the block's knob until the L is on top for Left or the R is on top for Right

Note: To assist in changing the Left or Right orientation (L/R), the shaft of the Revision Screwdriver may be placed lengthwise between the two knobs of the L/R dial and rotated 180 degrees.

To set the block to the correct A/P starting position, Insert the Revision Screwdriver into the hex head on the block, PUSH and turn clockwise. (To change the setting, the hex head must first be pushed in to shift the block) (Figure 46).

Note: The block should be set up in the +2 position (Fem Post) to begin. The lines on the side of the knob should line up with the etched lines for the desired position.

Once done, slide the block proximally onto the threaded shaft with the appropriate Left/Right (L/R) orientation on top (Figure 47).

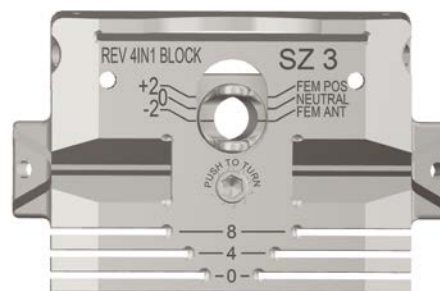

The Revision 4-in-1 Cutting Block

As the Screwdriver is turned clockwise, the +2,0,-2 knob shifts downwards

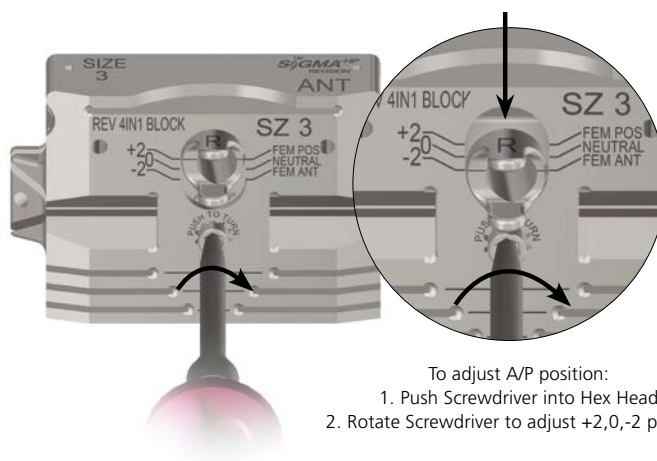

Figure 46

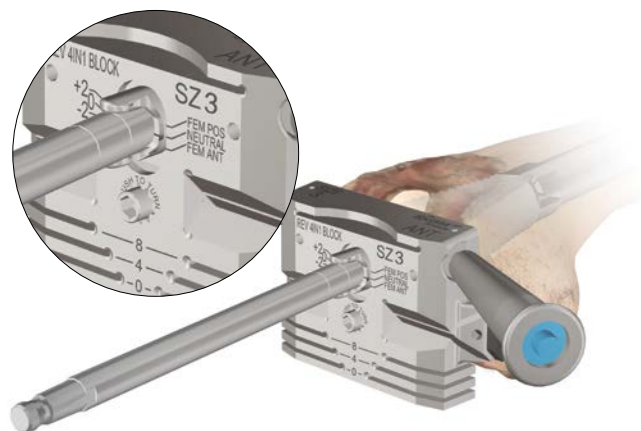

Figure 47

FEMORAL PREPARATION – A/P AND CHAMFER CUTS

Rotational positioning of the Revision 4-in-1 Cutting Block is critical to the establishment of a symmetrical flexion gap and patellofemoral alignment. The correct block rotation should have the posterior surface of the cutting block parallel to the resurfaced proximal tibia under tension. Validate symmetry with the HP Revision M.B.T. Spacer Blocks (Figure 48).

Note: The Revision M.B.T. Spacer Blocks are designed to rest on top of the M.B.T. Revision Tray Trial and underneath the posterior portion of the 4-in-1 Cutting Block, providing both the appropriate tension and the correct insert thickness.

Optional: If desired, Alignment Rods may be introduced through the handle of the spacer block. This may be helpful in assessing alignment. Rods can be inserted vertically (to assess the mechanical axis) and horizontally (to assess tibial cut accuracy) (Figure 49).

Optional: Balanced Block Handles can be used to rotate the block and to hold the block in place during final resection.

Where asymmetry exists, additional soft-tissue balancing may be indicated. Confirm positioning by assuring parallel alignment of the cutting block with the transepicondylar axis or the proximal tibia.

Introduce the Angel Wing into the anterior saw slot to check the anterior resection and ensure femoral notching does not occur.

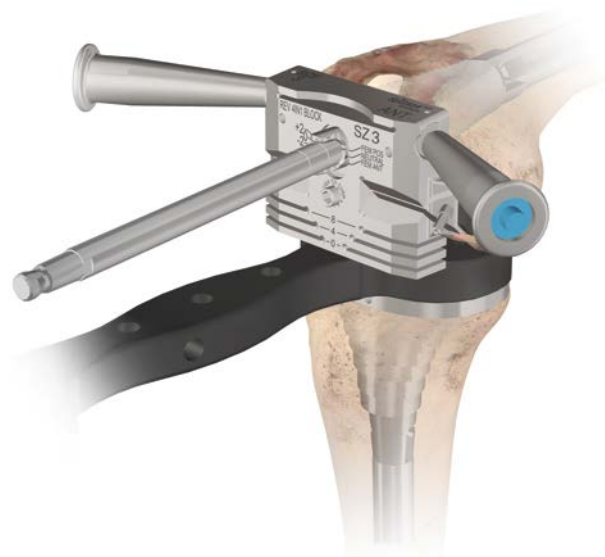

Figure 48

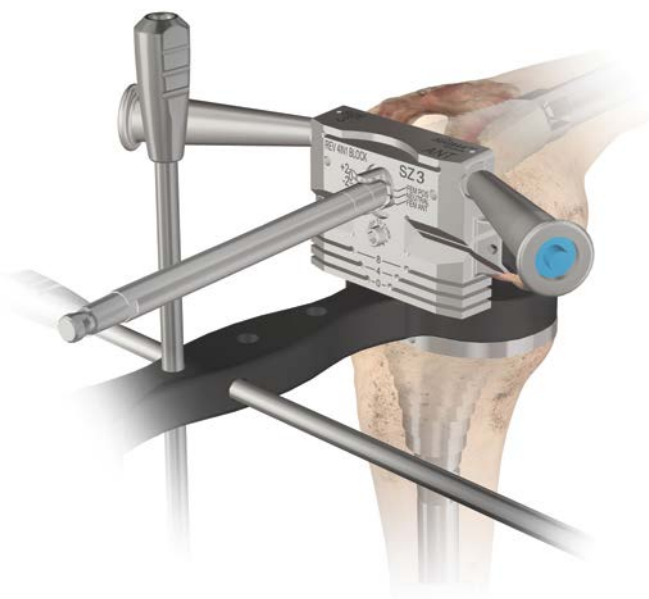

Figure 49

FEMORAL PREPARATION – A/P AND CHAMFER CUTS

If the flexion gap is loose relative to the extension gap, the next larger size femoral component can be used and the posterior condyles augmented.

If the flexion gap is too tight relative to the extension gap, the block can be moved from the +2 setting (Femoral Posterior) to the 0 (Neutral) or -2 setting (Femoral Anterior) (Figure 50).

Note: The block should not be shifted from one setting to another with the spacer block, pins, or any tensioning device in place.

With rotation and gap balancing confirmed, secure the Cutting Block with HP Threaded Pins introduced through the side Convergent Pin holes.

Note: If additional fixation is required use threaded non-headed pins in the anterior pin holes. Use caution when using headed threaded pins if a gap exists between the distal spacers and the distal bone.

The pins will pass through the block and then through the Distal Spacer (if used), fixing the block in place (Figure 51). Once locked in place perform the anterior, posterior, and chamfer cuts.



Figure 50



Figure 51

FEMORAL PREPARATION – A/P AND CHAMFER CUTS

Anterior resection is performed through the anterior slot using a 1.19 mm ½ inch wide Saw Blade (Figure 52).

Note: The blocks feature an etched line on the side of the block. This line on the block represents the distal joint line of the femoral component.

Posterior resection is through the slot designated 0 or, where there is posterior condylar deficiency, use the appropriate 4 or 8 mm slot to accommodate the projected augmentation (Figure 53).

Once Anterior and Posterior resections are complete proceed with the Anterior and Posterior chamfer cuts (Figures 54 and 55).

Note: If pins were used in the straight anterior pin holes for additional fixation, they must be removed prior to making the anterior chamfer cut.

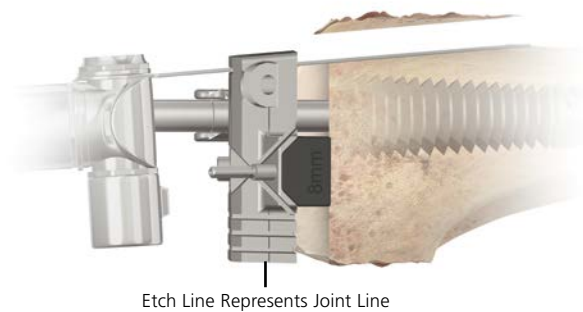

Etch Line Represents Joint Line

Figure 52

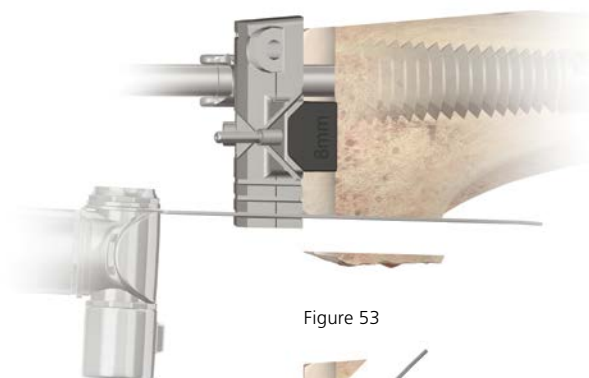

Figure 53

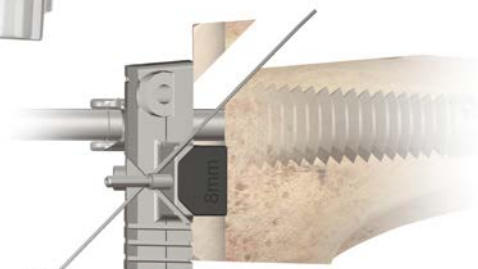

Figure 54

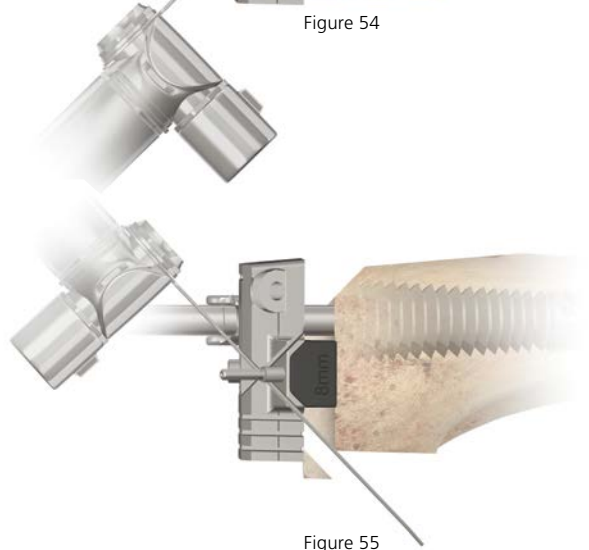

Figure 55

FEMORAL PREPARATION – NOTCH RESECTION

Select the appropriate sized Revision Notch Guide, based upon the size of the Revision 4-in-1 Block used. If distal spacers were used for the 4-in-1 cuts, insert the same distal spacers into the Notch Guide on the appropriate side (Figure 56).

Select the appropriate Notch Guide Bushing. This corresponds to the Right/Left Block knob position and the 0 mm (Neutral), +2 mm (Fem Pos) or -2 mm (Fem Ant) position that was used on the 4-in-1 Cutting Block. Assemble it onto the Notch Guide with the appropriate Right/Left and 0, +2 or -2 designation facing up and lock into position by rotating the tabs anteriorly to the stop (Figure 57).

Note: The width of the Notch Guide corresponds to the final implant width (Figure 57).

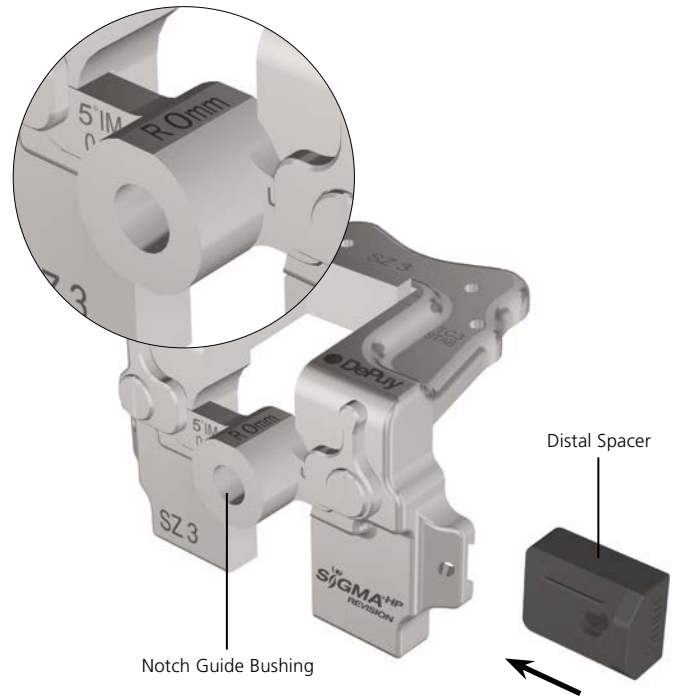

Figure 56

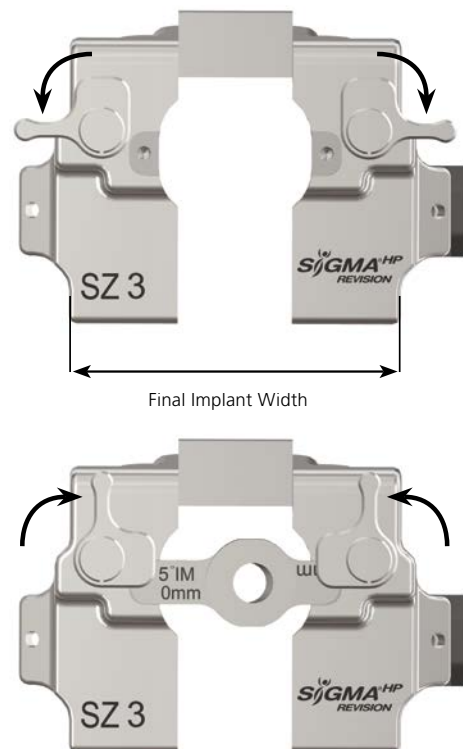

Figure 57

FEMORAL PREPARATION – NOTCH RESECTION

Assemble the Notch Guide onto the threaded shaft and advance to the prepared distal surface (Figure 58).

If assistance is needed in re-establishing the rotation of the Notch Guide, the HP Revision M.B.T. Spacer Block may be used between the M.B.T. Revision Tibial Trial and the posterior side of the Notch Guide to re-establish desired rotation from the 4-in-1 Block.

Once desired rotation is set, use Non-Headed Pins in the convergent pin holes to lock the Notch Guide in place. The pins will go through both the Notch Guide and the distal spacers (if used) (Figure 59).

If necessary, introduce Non-Headed Pins in the sequence displayed (Figure 59):

1. Anterior
2. Contralateral distal
3. Anterior
4. Distal

Note: Care should be taken not to insert pins too far into anterior bone.

Remove the notch bushing and the threaded shaft (if used). Ensure the Notch Guide orientation does not change and the Notch Guide is still rigidly fixed in place.

Note: The length of the intercondylar box differs for the P.F.C. SIGMA Stabilized and TC3 femoral components. Care should be taken to ensure that the appropriate cut is made through the Notch Guide.

The TC3 box cut is made through the proximal surface of the anterior Notch Guide (through the slot) and the Stabilized or PS box cut is made on top of the slot (Figure 60). Perform the resection either with an Oscillating Saw and a ½'inch wide blade or a Reciprocating Saw (Figure 60).

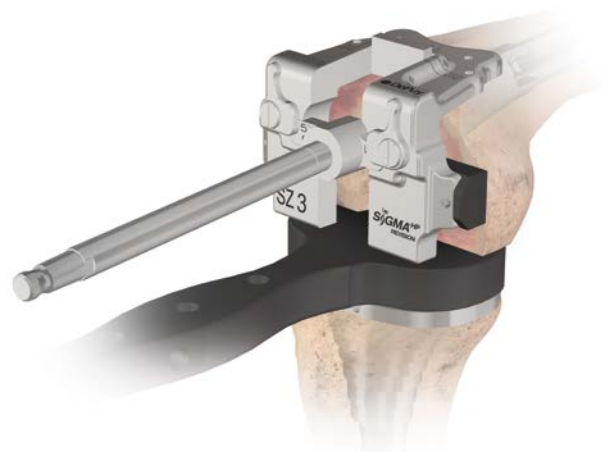

Figure 58

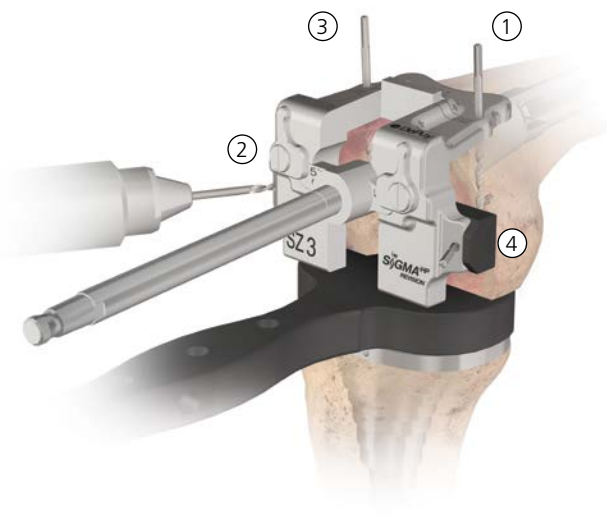

Figure 59

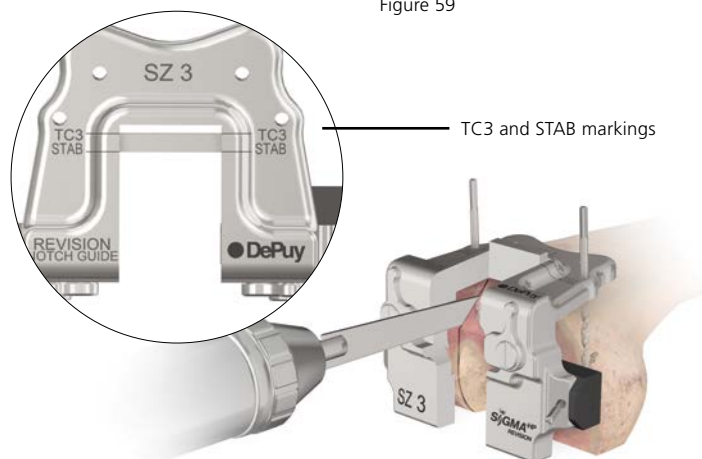

Figure 60

FEMORAL TRIAL ASSEMBLY

The Femoral Component Box Assembly

- 1) Place the two outrigger tabs of the box trial into the recesses of the posterior condyles on the corresponding size trial femoral component (Figure 61).
- 2) Insert the two anterior tabs into the recesses of the anterior flange (Figure 62). If the anterior tabs won't fit, take the box out, insert the Screwdriver into the hex head and rotate counter clockwise, then reinsert.
- 3) Using the Screwdriver, adjust the hex screw at the posterior of the box trial until a "click" is heard from the Screwdriver (Figure 63).
- 4) Adjust the Femoral adapter position to the corresponding position 0 (Neutral), +2 (Fem Post), or -2 (Fem Ant and Right/Left (R/L)) from the Revision 4-in-1 Cutting Block and the notch guide bushing. (Pull up then translate to desired position (Figure 64). This can be done by hand or with the Femoral Adaptor Shift Tool. For further instructions, see Page 38 on how to adjust this positioning).

Note: Using the Screwdriver, tighten the hex screw until a "click" is heard from the Screwdriver. This will ensure secure assembly of the Box Trial to the Femoral Trial. Do not overtighten the Screw or attempt to remove the Screw from the Box Trial as this will result in damage to the Box Trial attachment.

Note: Do not over-loosen the Hex Screw when disassembling the femoral trial construct. The Screwdriver does not limit torque in the reverse direction.



Figure 61

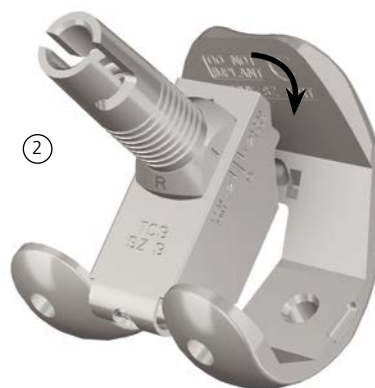

Figure 62

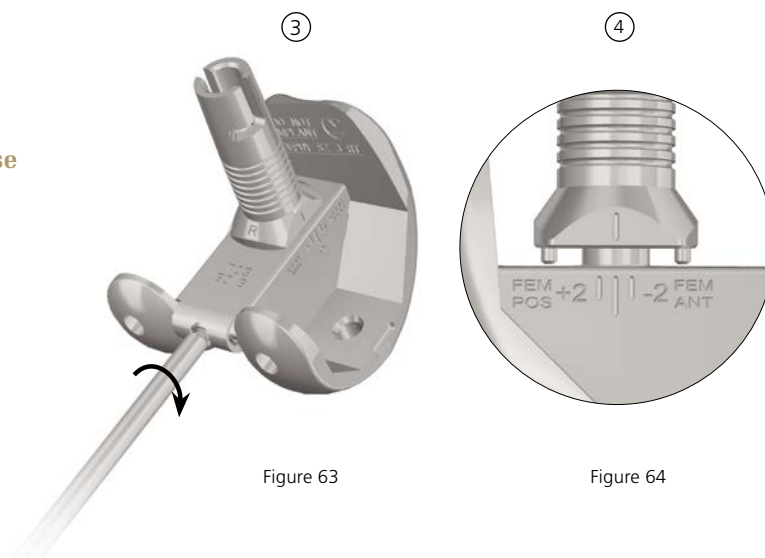

Figure 63

Figure 64

FEMORAL TRIAL ASSEMBLY

If the box trial adapter orientation needs to be adjusted, pull the adapter up and rotate 180 degrees to set the orientation to left or right. The correct orientation marking will be pointing towards the posterior condyles of the trial femoral component and will be indicated by an L for left and an R for right (Figure 65).

Ensure that the A/P positioning is correct. There are indicators on the side of the box to indicate +2 (which shifts the femoral component posteriorly/closes the flexion space), 0 (neutral), and -2 (which shifts the femoral component anteriorly/opens the flexion space) (Figure 65). This positioning should match the A/P setting established on the Revision 4-in-1 Block.

Note: To change the positioning, pull up on the Adapter and move the Adapter forward or backwards on the box until the desired +2, 0, or -2 location is reached. If this adjustment is difficult the Femoral Adapter Shift Tool may be used to aid in setting this adjustment (Figure 66).

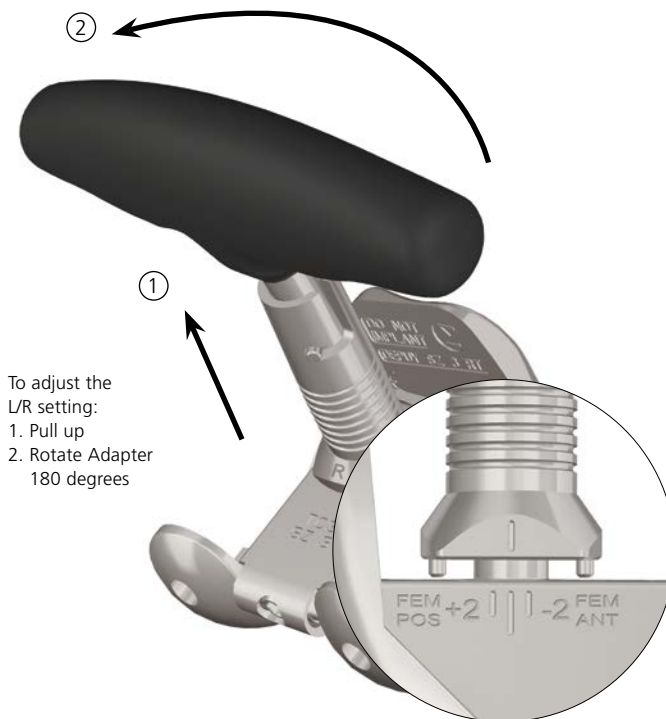

Figure 65

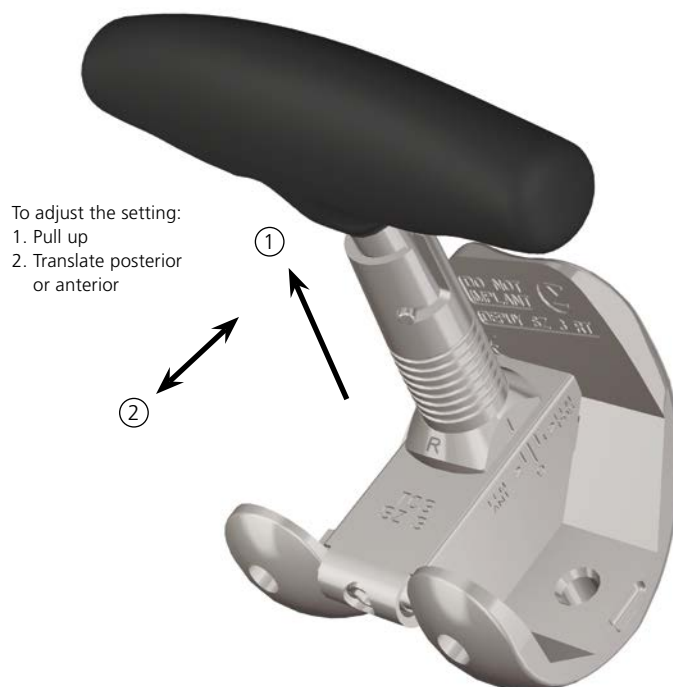

Figure 66

FEMORAL TRIAL ASSEMBLY – SLEEVE AND STEM USE

Trial assembly order

(with sleeve and stem use, see Figure 67):

- Assemble HP Revision TC3 Box Trial to the corresponding size Femoral Trial
- Assemble sleeve trial over adapter trial
- Partially tighten HP Revision Sleeve Bolt Trial with the Screwdriver to hold the construct in place
- Add stem trial to trial assembly
- Add posterior and distal augment trials, if needed
- Seat trial assembly on femur
- Once sleeve trial has achieved proper orientation, completely tighten with the Screwdriver until the "click" is heard

After assembling the HP Revision TC3 Box Trial to the femoral trial, set the femoral adapter on the box trial to the correct side (Left or Right) and position (+2,0,-2 mm) from the 4-in-1 Cutting Block and Notch Guide Bushing (Figure 67 - Step 1). Assemble the femoral sleeve trial corresponding in size to the final broach employed to the TC3 femoral trial assembly (Figure 67 - Step 2) and pass the HP Sleeve Bolt Trial through the hole in the box of the distal femoral trial and partially tighten using the Screwdriver (Figure 67 - Step 3). Make sure to properly orient the sleeve trial with the narrow side facing medially. Assemble the proper stem trial to the sleeve trial (Figure 67 - Step 4).

Note: Trial bolt lengths are different for adapter/sleeve use than for adapter/stem-only use, the bolt trials are marked accordingly "SLEEVE BOLT" or "STEM BOLT".

Note: Do not completely tighten down the bolt prior to seating the trial construct into the canal. Leave the sleeve slightly loose so that it finds its proper rotation/orientation as it is being inserted into the canal.

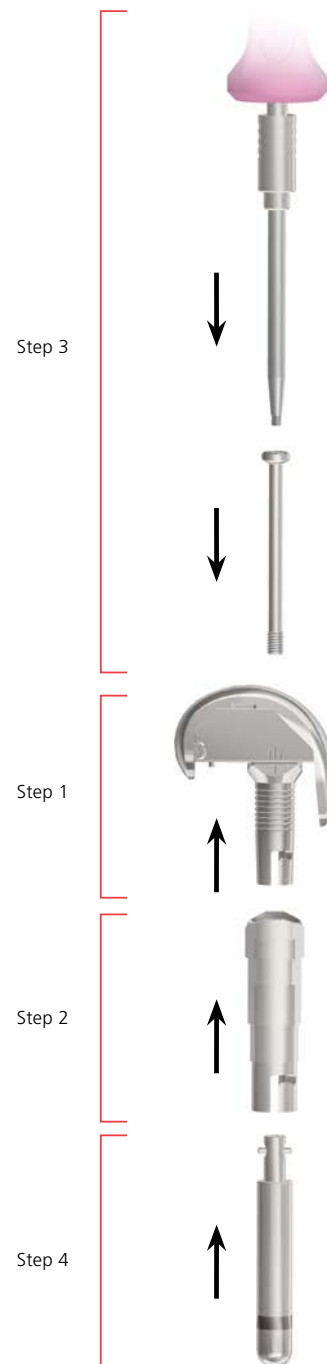

Figure 67

FEMORAL TRIAL ASSEMBLY – SLEEVE AND STEM USE

The sleeve bolt mechanical connection to the sleeve trial/ adapter/femoral trial construct helps to ensure that the parts do not disassociate during use.

Note: Please consult the anterior width chart on page 64 (in the Appendix) to determine the sleeve/ femoral component compatibility and the distance between the anterior chamfer and the anterior aspect of the sleeve.

Where augmentation is employed, assemble the appropriate trial distal and posterior augmentation components to the trial femoral component (Figure 68).

Remove the sleeve broach with the broach handle.

Seat the femoral trial in the femur. The sleeve trial will achieve the rotation and orientation of final broach used. After the femoral trial with sleeve is seated securely in the metaphysis, tighten the sleeve bolt trial with the screwdriver until the "click" is heard (Figure 69).



Figure 68



Figure 69

FEMORAL TRIAL ASSEMBLY – STEM-ONLY USE

Trial assembly order (with stem-only use, Figure 70):

- Assemble HP Revision TC3 Box Trial to the corresponding size femoral trial
- Tighten HP Revision Stem Bolt Trial with the Screwdriver
- Add stem trial to trial assembly
- Add posterior and distal augment trials, if needed
- Seat trial assembly on femur

After assembling the HP Revision TC3 Box Trial to the Femoral Trial, set the Femoral Adapter on the box trial to the correct side (Left or Right) and position (+2,0,-2 mm) from the Revision 4-in-1 Cutting Block and Notch Guide Bushing (Figure 70 - Step 1). Pass the Stem Bolt Trial through the hole in the box of the distal femoral trial and tighten using the HP Revision Screwdriver (Figure 70 - Step 2). Assemble the proper stem trial to the box trial (Figure 70 – Step 3).

Note: Trial bolt lengths are different for adapter/sleeve use than for adapter/stem-only use, the bolt trials are marked accordingly "SLEEVE BOLT" or "STEM BOLT".

The stem bolt mechanical connection to the Adapter/ Femoral Trial construct helps to ensure that the parts do not translate during use.

Where augmentation is employed, assemble the appropriate trial distal and posterior augmentation components to the trial femoral component.

Seat the femoral trial in the femur.

Note: The stem bolt must be used for a stem only trial. Failure to use the stem bolt will result in an inaccurate reading of varus/valgus stability during trialing.



Figure 70

FEMORAL TRIAL ASSEMBLY – SLEEVE-ONLY USE

Trial assembly order (with Sleeve-only use, Figure 71):

- Assemble HP Revision TC3 Box Trial to the corresponding size Femoral Trial
- Assemble sleeve trial over adapter trial
- Partially tighten HP Revision Sleeve Bolt Trial with the Screwdriver to hold the construct in place
- Add posterior and distal augment trials, if needed
- Seat trial assembly on femur
- Once sleeve trial has achieved proper orientation, completely tighten with the Screwdriver until the "click" is heard

After assembling the HP Revision TC3 Box Trial to the femoral trial, set the femoral adapter on the box trial to the correct side (Left or Right) and position (+2,0, -2 mm) from the Revision 4-in-1 Cutting Block and Notch Guide Bushing (Figure 71 - Step 1). Assemble the femoral sleeve trial corresponding in size to the final broach employed to the TC3 Femoral Trial assembly (Figure 71 - Step 2) and pass the HP Revision Sleeve Bolt Trial through the hole in the box of the distal femoral trial and partially tighten using the Screwdriver (Figure 71 - Step 3). Make sure to properly orient the sleeve trial with the narrow side facing medially. Do not completely tighten down the bolt. Leave the sleeve trial slightly loose so that it find its proper rotation/orientation as it is being inserted into the canal.

Note: Trial bolt lengths are different for adapter/sleeve use than for adapter/stem-only use, the bolt trials are marked accordingly "SLEEVE BOLT" or "STEM BOLT".

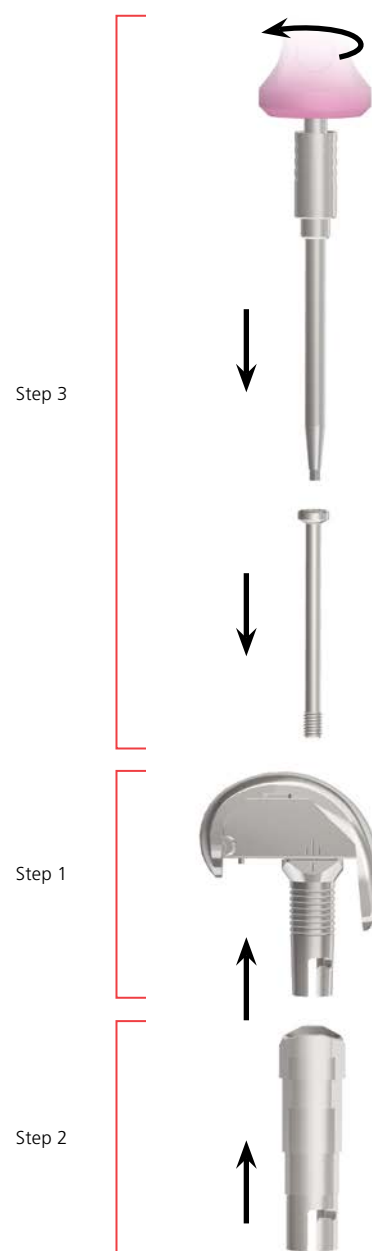

Figure 71

FEMORAL TRIAL ASSEMBLY – SLEEVE-ONLY USE

The sleeve bolt mechanical connection to the adapter/femoral trial construct helps to ensure that the parts do not disassociate during use.

Note: Please consult the anterior width chart on page 64 (in the Appendix) to determine the sleeve/femoral component compatibility and the distance between the anterior chamfer and the anterior aspect of the sleeve.

Where augmentation is employed, assemble the appropriate trial distal and posterior augmentation components to the trial femoral component. Remove the sleeve broach with the broach handle. Seat the femoral trial in the femur. The sleeve trial will achieve the rotation and orientation of final broach used. After the sleeve trial is seated securely in the metaphysis, tighten the sleeve bolt trial with the screwdriver until the "click" is heard.

FINAL PREPARATION OF THE TIBIA

Assess proximal tibial coverage and rotation of tibial component. Impact the appropriate Keel Punch (utilize the cemented Keel Punch if a cement mantle is desired or the press-fit Keel Punch if line-to-line contact is desired) (Figure 72). The base plate should be positioned to provide the best coverage of the tibial condylar surface.

Leave the Keel Punch in place for trial reduction and insert the polyethylene Trial (Figure 73).

Note: PS or CR M.B.T. Insert Trials may be used at this point to assess construct stability. Using these trials will allow easier insertion onto the keel and will provide a better idea on how well the gaps are balanced.



Figure 72



Figure 73

PREPARATION OF THE PATELLA

Where replacement of the patellar component is indicated, it is important that the anteroposterior dimension be maintained and that adequate bone stock be preserved. Problems arise from inadequate, excessive or uneven resection resulting in abnormal anteroposterior dimension to the complex, subsequent patellar tilt and implant wear.

Free sufficient soft tissue at the prepatellar bursa to position Calipers at the anterior cortex.

Where residual bone stock is adequate, implantation of the replacement prosthesis is essentially routine. Where inadequate, patelloplasty may be indicated.

Note: The normal anteroposterior patellar dimension is 22–24 mm in the female, 24–26 mm in the male (Figure 74).



Figure 74

PREPARATION OF THE PATELLA

Meticulous disruption of the bone/prosthesis interface is essential. It is performed with thin Osteotomes and thin Oscillating Saw Blades. Avoid excessive leverage to minimize possible fracturing.

Position the Patellar Template that most adequately covers the prepared surface along the horizontal axis of the patella and firmly engage. Fashion the three holes for the fixation pegs of the component with the appropriate drill (Figure 75). Depth is governed by the collar.

Implanting the Patellar Component

Perform patellar implantation when convenient.

Cleanse the site with pulsatile lavage, dry, and apply methyl methacrylate cement. Insert the component into the prepared holes and position the Patellar Clamp.

The clamp is designed to fully seat and stabilize the implant. Position it with the silicone O-ring centered over the articular surface of the implant and the metal backing plate against the anterior patellar cortex, avoiding skin entrapment. When snug, the handles are closed and held by the ratchet until polymerization is complete (Figure 76). Avoid excessive compression as it can fracture osteopenic bone. Remove all extruded cement with a Curette.

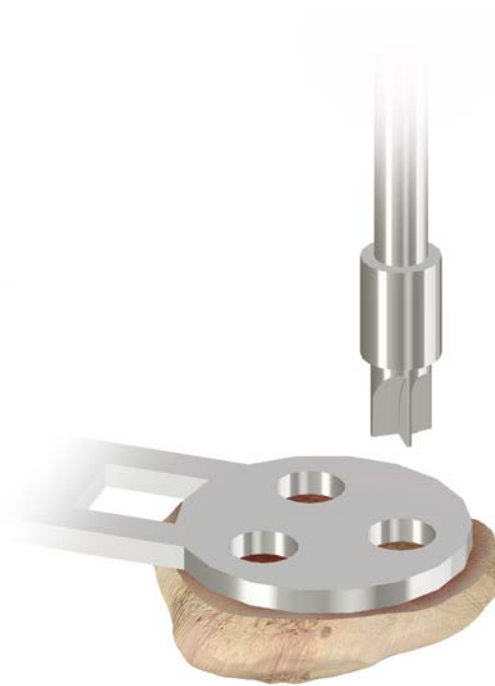

Figure 75



Figure 76

IMPLANT ASSEMBLY - TIBIA

Tibial Sleeve Assembly

Note: It is imperative to assemble the sleeve prior to stem attachment.

Note: Sleeves and step wedges can only be used together if using a 29 mm Sleeve.

Remove trial component in one piece (use as guide for assembly of implants).

Place the M.B.T. Revision Tray on a firm, stable, padded surface. Set the tibial sleeve in an orientation that matches the prepared canal. Matching the orientation of the tray/sleeve trial is helpful in determining appropriate rotation of the final tibial tray/sleeve implant (Figure 77). The sleeve can rotate 20 degrees internally or externally.

Using the Sleeve Impactor and a mallet, impact the sleeve onto the M.B.T. Revision Tray. Deliver several strikes to engage the two components (Figure 78).

Stem Component Assembly

Attach the stem extension to the prosthetic tray using the two appropriate wrenches to ensure full engagement (Figure 79).

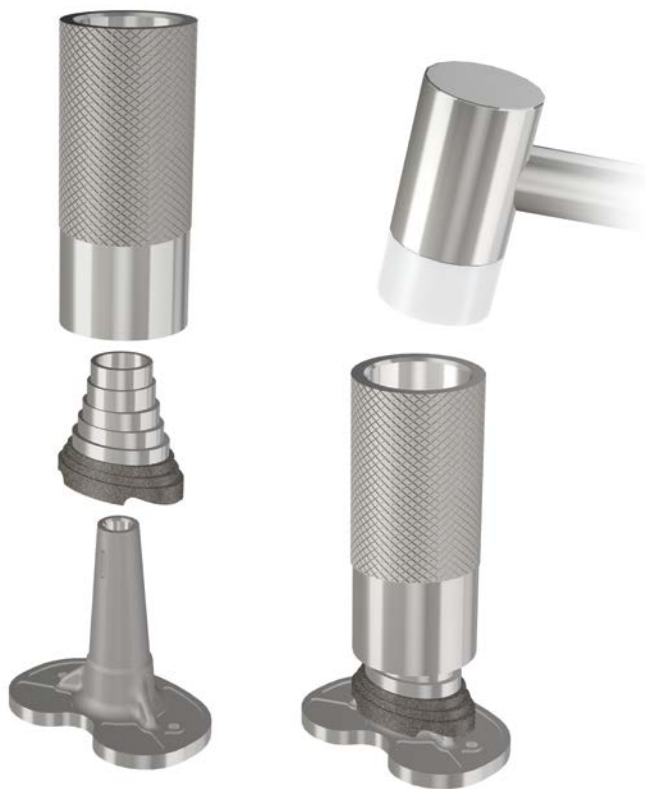

Figure 77

Figure 78

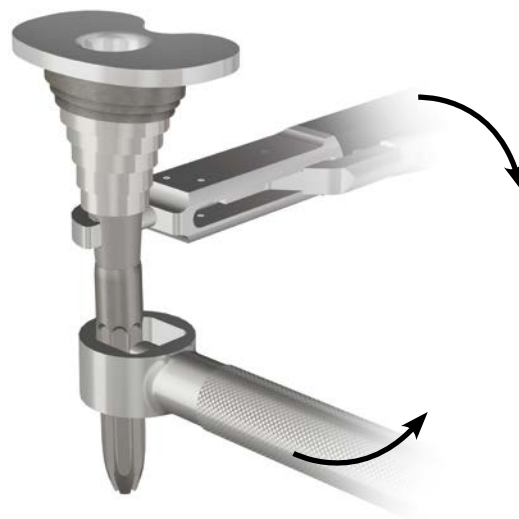

Figure 79

TIBIAL IMPLANTATION

Implanting the Tibial Component

Thoroughly cleanse the site with pulsatile lavage. Perforate with small drill holes on the prepared tibial surface to facilitate penetration of methyl methacrylate cement (Figure 80). Pack residual small cavitory bone defects with cancellous autograft, if available, or allograft.

Apply methyl methacrylate cement to the proximal tibial surface (Figure 81) or directly to the underside of the tibial tray component.

When a fluted stem or a fluted stem with a metaphyseal sleeve is used, ensure the medullary canal remains free of cement. Clear all extruded cement with a curette.

Seat the tibial implant construct into the prepared tibia by impacting the RP Tray Impactor and Universal Handle assembly (Figure 82).

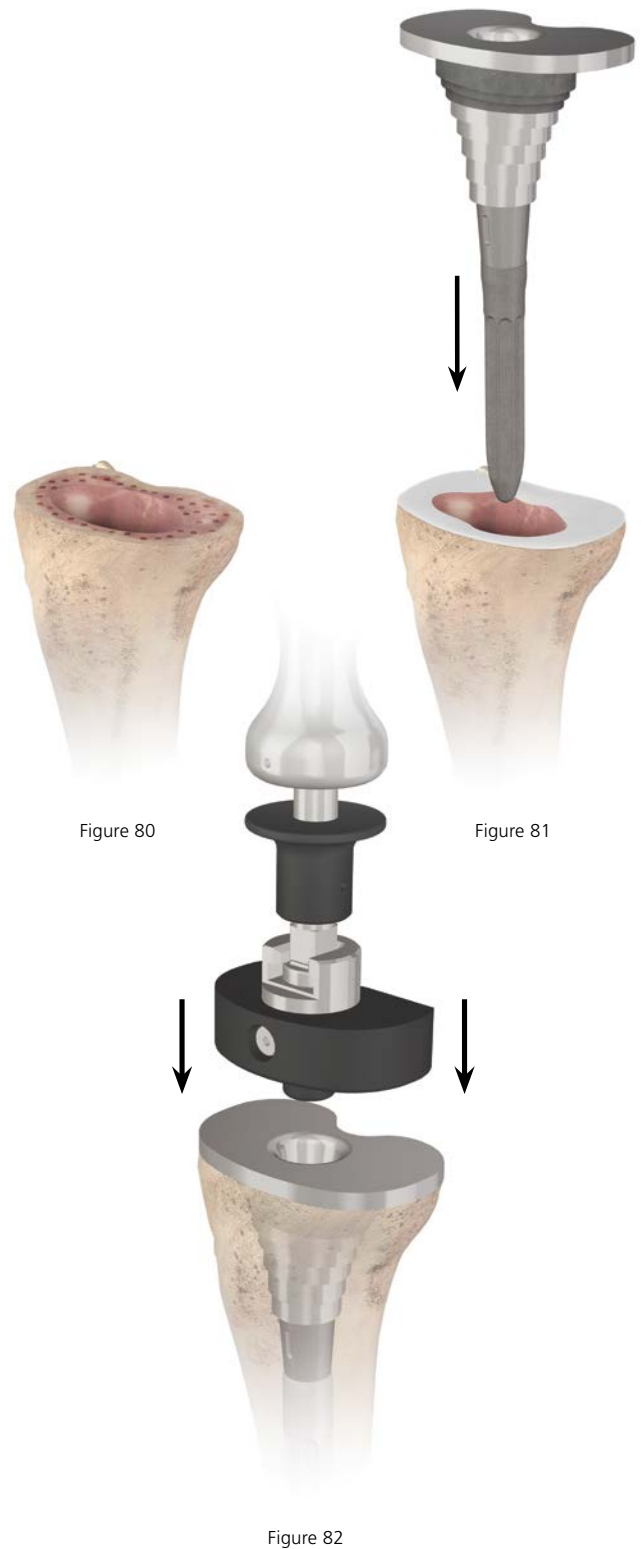

IMPLANT ASSEMBLY – SIGMA FEMORAL ADAPTER

Remove the assembled femoral trial components and clean the site thoroughly using pulse lavage before implantation. Before prostheses implantation proceeds, attach all augments, sleeves and modular stems to the femoral component.

Pass the appropriate P.F.C. SIGMA Femoral Adapter Bolt, neutral or +/-2 mm, corresponding to the position selected for the Revision 4-in-1 Cutting Block and the bushing for the notch guide through the hole of the distal femoral component and into the P.F.C. SIGMA Femoral Adapter (Figure 83).



Figure 83

Arrow Indicator	Box Trial	Final Implant
↑ +2 mm		
↕ 0 mm		
↓ -2 mm		

IMPLANT ASSEMBLY – SIGMA FEMORAL ADAPTER

Tighten the construct until the base of the adapter is flush with the femoral box. The three A/P etch marks on the base of the adapter implant should face laterally. From the posterior view of the assembly, the angle (5 degrees) and orientation (L or R) will be legible (Figure 84).

Attach the P.F.C. SIGMA Femoral Adapter holding clamp to the femoral implant and tighten it. The clamp provides the second moment arm needed to assemble the parts. Place the torque wrench over the P.F.C. SIGMA Femoral Adapter implant and move it clockwise to tighten the adapter to the femoral implant (Figure 84). The torque wrench has a deflection beam, which indicates when sufficient torque has been applied (Figure 85).

Note: Torque the assembly to the 270 in. lb mark on the torque wrench to ensure proper assembly torque (Figure 85).

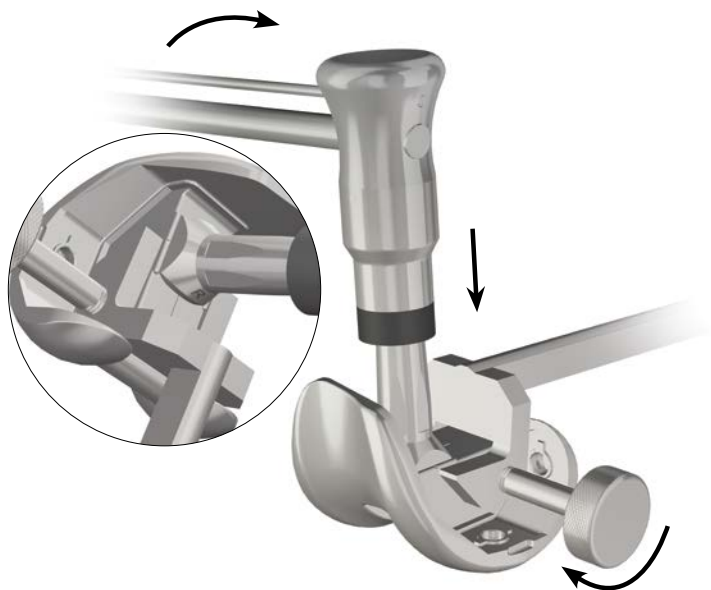

Figure 84

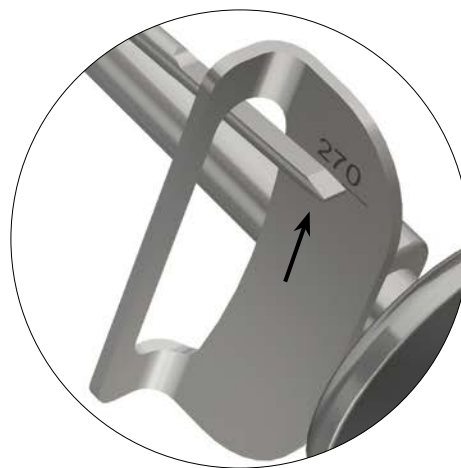

Figure 85

IMPLANT ASSEMBLY – SIGMA FEMORAL AUGMENTS

Attach the femoral augments using the wobble bits included in the augment package. Attach the femoral augments to the femoral component using the augment T-handle provided (Figures 86 and 87). It may be necessary to use the T-handle extension in conjunction with the T-handle to attach the augments.

Fully seat the augments on the component before tightening the screw thread mechanism. Carefully tighten with the large T-handle Torque Driver until an audible "click" is discerned.

The augment assembly sequence is shown below. For implant assembly: sleeve and stem proceed to page 51, stem-only proceed to page 53, and sleeve-only proceed to page 54.

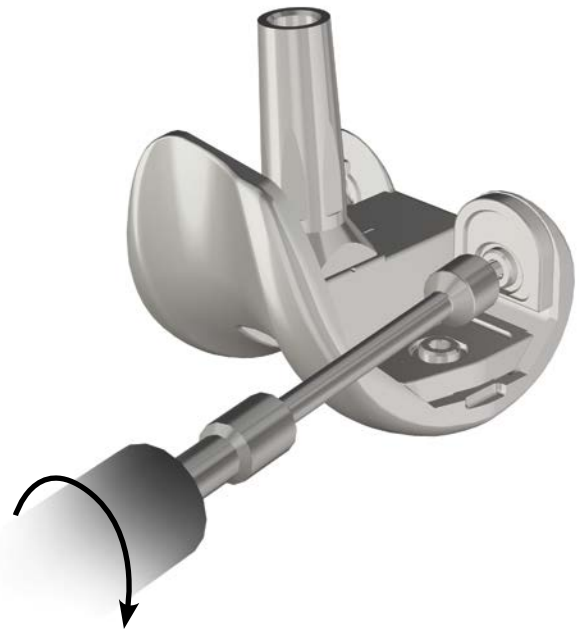

Figure 86



Figure 87

Assembly Rules for Femoral Augmentation

1. For Size 1.5 Femoral Components
 - Distal augmentation component augments in 4, 8 and 12 mm thicknesses
 - Assemble last
2. For Size 4n PS Femoral Components
 - Use size 2 distal and posterior augments
3. For 4 mm/8 mm Augments
 - They are fully interchangeable
 - If using 4 mm or 8 mm distal with posterior augment, install distal first
4. For 12 mm/16 mm Distal Augment
 - Use 16 mm distal augment with TC3 femoral only
 - Femoral stem is indicated
 - On size 2, 2.5 and 3 femoral component, use 4 mm posterior only
 - On size 4, 5 femoral component, may use 4 or 8 mm posterior
 - **(Note: No size 6 augments available - use size 5 distal augments and size 3 posterior augments with size 6 femoral component)**
 - If using with posterior augment, install posterior augment first

IMPLANT ASSEMBLY – SLEEVE AND STEM USE

Implant Assembly - Sleeve and Stem Use

Implant assembly order (with sleeve and stem use):

- Femoral adapter-to-femoral component
- Add posterior and distal augments, if necessary
- Sleeve-to-stem
- Sleeve construct-to-femoral adapter construct

To attach the Universal Stem to the universal femoral sleeve, thread the stem onto the sleeve. Grasp the sleeve with the tibial sleeve clamp and use the stem Extension Wrench to grasp the Universal Stem and tighten (Figure 88).

Apply sufficient force to both wrenches to ensure that the stem is secure.

Place the femoral component with the femoral adapter on a firm, stable surface. Place the appropriate sleeve and stem construct on top of the femoral adapter assembly (Figure 89).

Use the sleeve and femoral trial construct trial to help set the final sleeve and femoral component implant rotation.

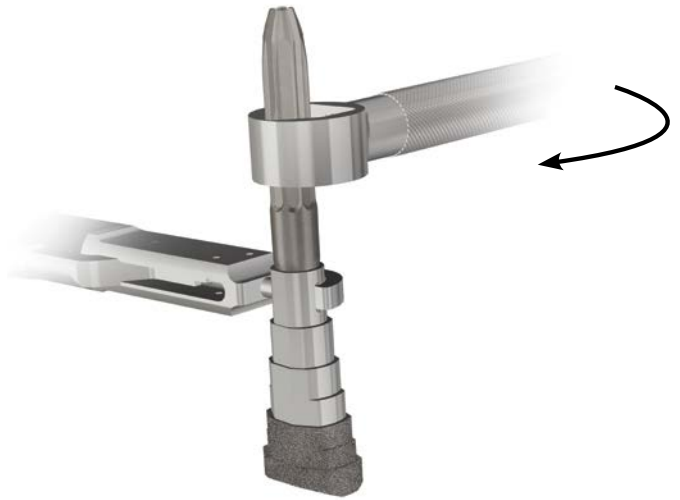

Figure 88



Figure 89

IMPLANT ASSEMBLY – SLEEVE AND STEM USE

Slide the femoral stem/sleeve impactor on top of the stem and forcefully apply three strikes with a mallet to engage the two component assemblies (Figure 90).

Note: The femoral stem/sleeve Impactor has two uses, one end for use of a sleeve without a stem extension and one end for a sleeve and stem combination.

The definitive components are implanted in the following order:

- Tibial tray (with stem, sleeve and/or wedges)
- Femoral component (with stem, sleeve and/or augments)
- SIGMA Rotating Platform PS or TC3 inserts

Implant the femoral component using the Femoral Impactor (Figure 91).

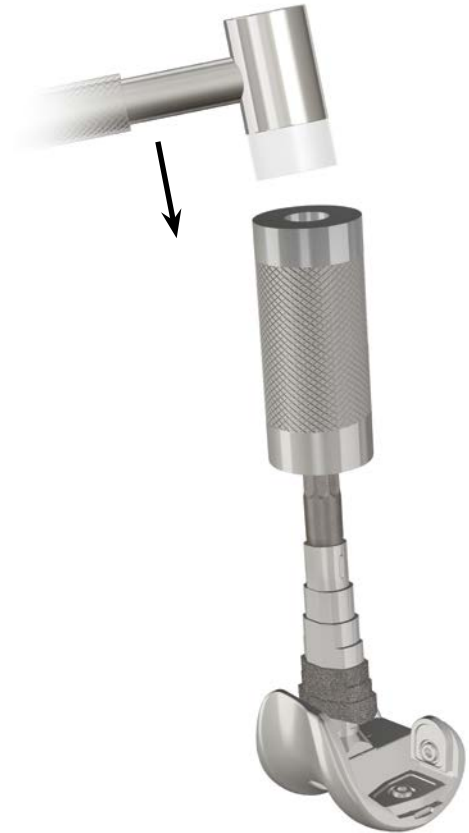

Figure 90



Figure 91

IMPLANT ASSEMBLY – STEM-ONLY USE

Implant Assembly - Stem Only

Implant assembly order (with Stem-only use):

- Femoral adapter-to-femoral component
- Add posterior and distal augments, if necessary
- Stem-to-femoral adapter

To attach the Universal Stem to the P.F.C. SIGMA Femoral Adapter, thread the stem onto the adapter.

With the P.F.C. SIGMA Femoral Adapter holding clamp in place, use the Stem Extension Wrench to grasp the Universal Stem and tighten (Figure 92). Apply sufficient force to both the P.F.C. SIGMA Femoral Adapter holding clamp and Stem Extension Wrench to ensure that stem is secure.

The definitive components are implanted in the following order:

- Tibial Tray (with stem, sleeve and/or wedges)
- Femoral component (with stem and/or augments)
- SIGMA Rotating Platform PS or TC3 inserts

Implant the femoral component using the Femoral Impactor (Figure 93).



Figure 92

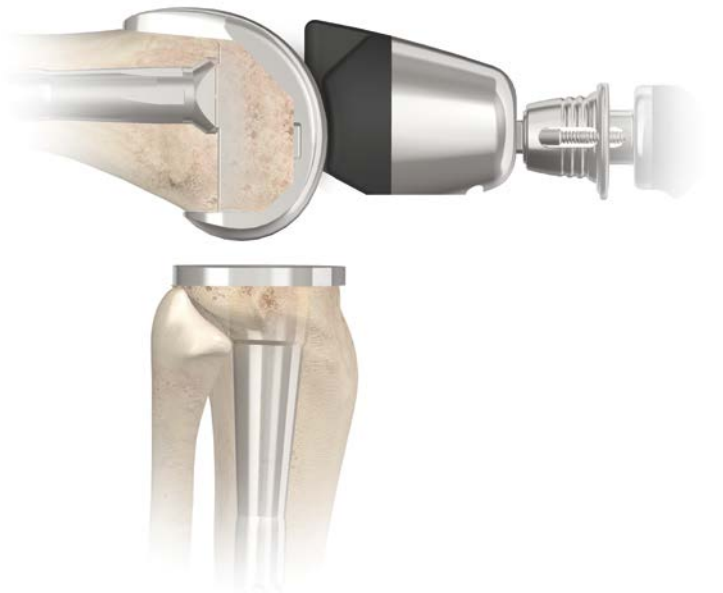

Figure 93

IMPLANT ASSEMBLY – SLEEVE-ONLY USE

Implant Assembly - Sleeve Only

Implant assembly order (with sleeve-only use):

- Femoral adapter-to-femoral component
- Add posterior and distal augments, if necessary
- Sleeve-to-femoral adapter

Slide the femoral stem/sleeve Impactor on top of the sleeve and forcefully apply three strikes with a Mallet to engage the two components (Figure 94).

Note: The femoral stem/sleeve impactor has two uses, one end for the sleeve without a stem extension and one end for a sleeve and stem combination.

The definitive components are implanted in the following order:

- Tibial tray (with stem, sleeve and/or wedges)
- Femoral component (with sleeve and/or augments)
- SIGMA Rotating Platform PS or TC3 inserts

Implant the femoral component using the femoral impactor.



Figure 94

FINAL TRIAL WITH IMPLANTS

Place the Revision Trial Post into the cone of the M.B.T. Revision implant. Seat the appropriate trial insert in the trial post/tray (Figure 95).

Assemble the appropriate femoral implant construct (see pages 51-54), apply the appropriate cementation technique and impact the femoral implant construct into the prepared femur.

Fully extend the knee to maintain pressure as the cement polymerizes (Figure 96).

Note: With constrained femoral and tibial components in trial reduction, it may be appropriate to cement the tibial tray implant and the femoral implant using the insert trial. This will allow visibility of final rotation.

Note: PS or CR M.B.T. Insert Trials may be used in the place of TC3 insert trials during this step. Using these trials will allow easier insertion onto the keel and will provide a better idea on how well the gaps are balanced.

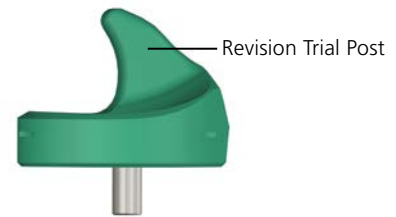

Figure 95

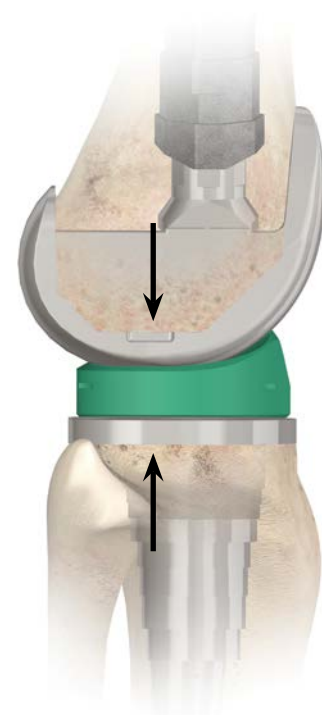

Figure 96

APPENDIX 1: THE CEMENTED TIBIAL STEM EXTENSIONS

Cemented Stem Reamer

Align the tibial tray and secure with two Fixation Pins inserted through the holes designated (Figure 1).
Seat the M.B.T. Revision Drill Bushing onto the tibia trial.
Place in the posterior holes.

Place the cemented drill bushing into the M.B.T. Revision Drill Bushing (Figure 2).

Use the “cemented” reamer to ream to the predetermined selected depths for tray only or the tray with a 30 or 60 mm cemented stem.

Remove the reamer and “cemented” bushing, leaving the tray trial and M.B.T. Revision Drill Bushing in place (Figure 3).

Note: Only a 13 mm diameter cemented stem should be used in conjunction with the M.B.T. Revision Tray to avoid a step off at the stem/tray junction.

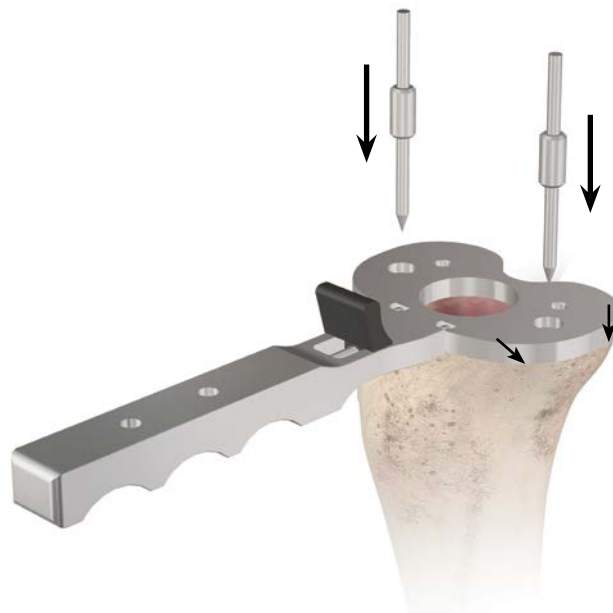

Figure 1

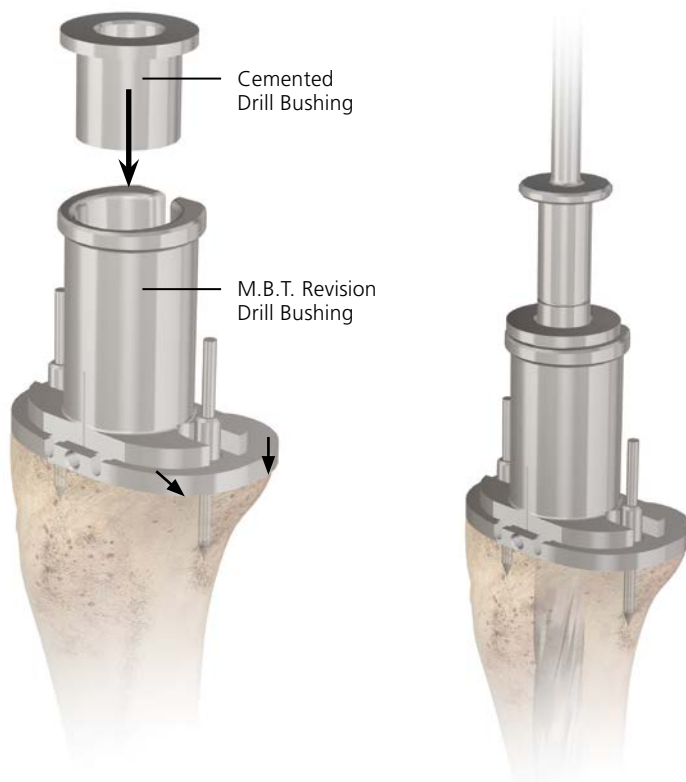

Figure 2

Figure 3

APPENDIX 1: THE CEMENTED TIBIAL STEM EXTENSIONS

Tapered Reamer

Assemble the revision reamer adapter onto the cemented tapered reamer.

Next, attach the modified Hudson Adapter to the tapered reamer, if power reaming.

Attach the appropriately sized cemented stem trial (13 x 30 mm or 13 x 60 mm) to the tapered reamer, if utilizing a cemented stem extension (Figure 4). Ream until the revision reamer adapter is flush with the M.B.T. Revision Drill Bushing (Figure 5).

Note: To avoid stem trial disengagement, do not reverse ream.

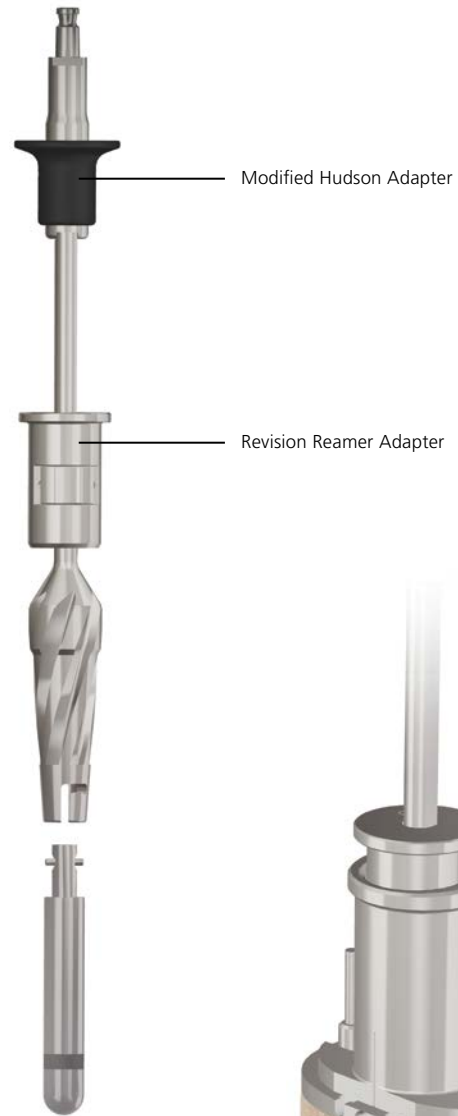

Figure 4



Figure 5

APPENDIX 1: THE CEMENTED TIBIAL STEM EXTENSIONS

Tapered Cemented Stems

Note: Tapered cemented stem sizes 13 x 90/120/150 mm are compatible with M.B.T. Revision Trays.

Ream the canal with a reamer two sizes larger than the stem. Ream the medullary canal with a 15 mm reamer to implant a 13 mm tapered cemented stem, which allows for a 1 mm circumferential cement mantle at the proximal end of the stem. The cement mantle will be greater around the distal end of the cemented tapered stem (3 mm per side).

This provides the following benefits:

- Thicker cement mantle distally helps assure that a circumferential mantle is present and reduces the possibility of thin or non-existent cement coverage of the stem distally
- Stresses are greatest at the tip of the stem. A larger cement mantle is advantageous in dissipating these stresses. Thinner cement mantles are more prone to breakdown when exposed to higher stresses

Tibial Keel Preparation

Place the knee in full extension and determine appropriate rotation of the tibial tray. Mark the appropriate rotation with electrocautery on the anterior tibial cortex at the center and sides of the alignment handle.

Assemble the appropriate stem trial to the M.B.T. Revision Tray Trial and seat in the prepared bone bed. Impact the cemented keel punch (Figure 6).

Disconnect the Universal Handle leaving the Keel Punch in place for trial reduction (if appropriate).

It is recommended that a Cement Restrictor be placed at the appropriate level prior to cementing the component. Use a Cement Gun to fill the canal with methyl methacrylate.



Figure 6

APPENDIX 2: STEP WEDGE PREPARATION

Step Wedge Augmentation

Resection for supplementary tibial augmentation may be based on the established position of the trial tray. Remove the femoral trial to provide greater access. Confirm rotational alignment of the Tibial Tray Stem Trial. Secure the tray with two Fixation Pins.

Attach the tray trial wedge cutting attachment with the Step Wedge Cutting Guide to the trial tray. The Step Wedge Cutting Block allows for a 5, 10, or 15 mm step wedge preparation, as necessary. Slide the block forward to the anterior proximal tibia and secure in place with two Steinmann Pins through the holes marked with □ (Figure 1).

Unlock the block and slide the assembly out of the block. Disconnect the handle from the trial tray (Figure 2).

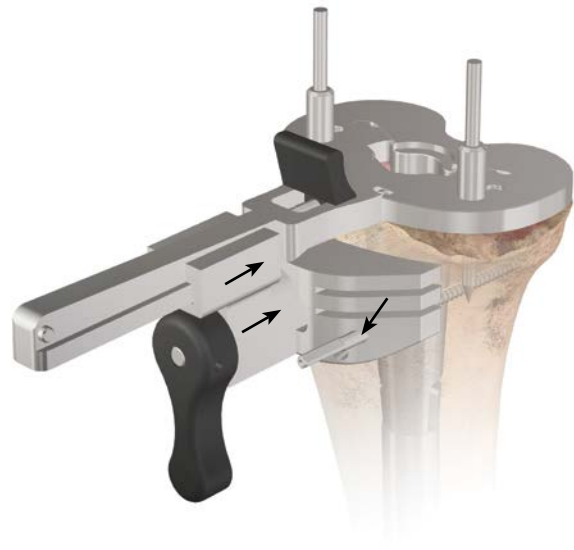

Figure 1

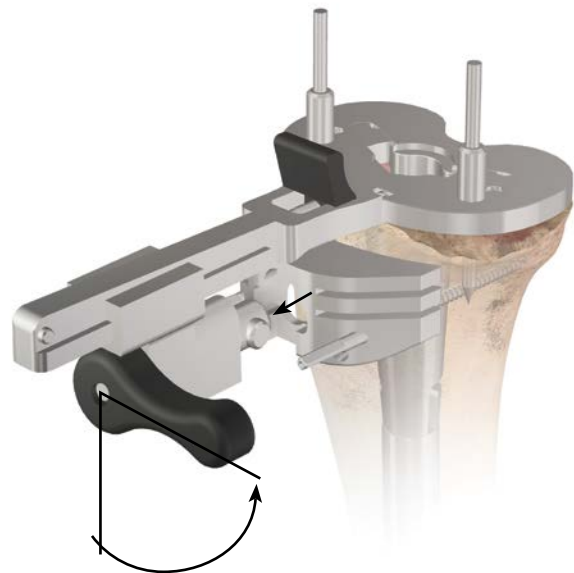

Figure 2

APPENDIX 2: STEP WEDGE PREPARATION

Trim the tibia accordingly with an Oscillating Saw so the cut does not extend beyond the central riser (Figure 3). Remove the block and pins.

Assemble the trial wedge to the appropriate tibial tray trial (Figure 4) and introduce into the prepared site. Perform minimal correction with a Bone File where indicated to ensure maximal contact.

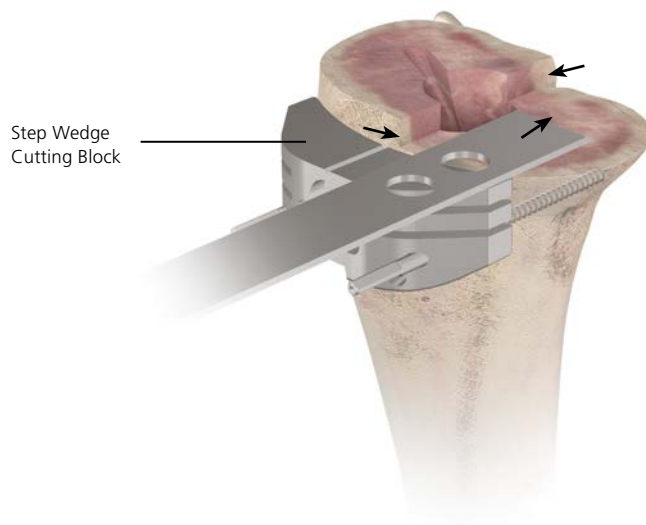

Figure 3



Figure 4

APPENDIX 2: STEP WEDGE PREPARATION

Confirm positioning, alignment and security of the tray assembly. If there is old cement or sclerotic bone, remove this first with a saw blade or burr prior to punching. Position the M.B.T. Revision Tibial Keel Punch at the tray and cancellous bone interface and impact into the keel configuration (Figure 5). Leave the punch in place and perform a final trial reduction if necessary.

Note: Utilize the “cemented” keel punch when a cement mantle is desired.

Alternative Step Wedge Preparation

This is a “free-hand” resection. Assemble the wedge trial and stem trial to the tibial tray trial. Position the device slightly proximal to the planned resection level. Make a conservative “free-hand” wedge resection and then check cuts with the trials (Figure 6).

Wedge Implant Assembly

Note: To aid wedge implant assembly, attach wedge prior to stem attachment.

Assemble the designated wedge to the tray and secure using the appropriate screw. Carefully tighten with the large T-handle torque driver until an audible “click” is discerned, ensuring a full and permanent interlock (Figure 7).



Figure 5

Figure 6



Figure 7

APPENDIX 3: THICK TRAY PREPARATION

After impacting the cement or press-fit keel punch, remove the keel punch. Insert the M.B.T. Thick Tray Trial Adapter (15 or 25 mm) onto the tibial tray trial (Figures 1 and 2).

Note: The tibial tray trial must be used with the thick tray adapters as the two pieces equal the appropriate sizing – 15 or 25 mm.

Perform the final trial reductions utilizing the same technique as the standard M.B.T. Revision Tray. Implant assembly and implantation is also the same as with the standard M.B.T. Revision Tray. If utilizing a wedge, refer to the step wedge preparation in Appendix 2.

Note: A tibial wedge can be used with all thick tray sizes, except for size 2. Sleeves may be used with all thick trays.

Note: Due to the taper, trial with appropriate tray trial size. For example, a size 4 thick tray tapers down to a size 2. Use the size 2 tray trial with the size 4 thick tray adapter. The size 3 thick tray tapers down to a size 1. And the size 2 thick tray tapers down to a size 0. The size 0 tray trial can be found in the M.B.T. thick tray instrument set.



Figure 1



Figure 2

APPENDIX 4: FEMORAL REVISION AND MBT REVISION TRAY COMPATIBILITY

	FEMORAL COMPONENTS															
	Size 1.5 53AP/57ML		Size 2 56AP/60ML		Size 2.5 59AP/63ML		Size 3 61AP/66ML		Size 4N 65AP/66ML		Size 4 65AP/71ML		Size 5 69AP/73ML		Size 6 74AP/78ML	
	PS	TC3	PS	TC3	PS	TC3	PS	TC3	PS	**	PS	TC3	PS	TC3	PS	**
M.B.T REVISION TRAYS																
Size 1 39AP/59ML	X	X														
Size 1.5 41AP/62ML	X	X	X	X												
Size 2 43AP/65ML	X	X	X	X	X	X										
Size 2.5 44AP/67ML			X	X	X	X	X	X								
Size 3 46AP/70ML					X	X	X	X	X		X	X				
Size 4 49AP/75ML							X	X	X		X	X	X	X		
Size 5 53AP/81ML									X		X	X	X	X	X	
Size 6 57AP/87ML													X	X	X	

**TC3 FEMURS ARE NOT AVAILABLE IN SIZE 4N OR 6

Note: RP insert must match femur size for size.

Note: For a size 4N femur, use a size 4 RP insert.

M.B.T. Revision Trays

- Made of Cobalt Chrome
- Tray thickness is 4.8 mm

M.B.T. Revision Thick Trays

- Made of Cobalt Chrome
- Tray thickness is 15 mm and 25 mm
- All thick trays taper distally by two sizes to match tibial anatomy.

M.B.T. Revision Thick Tray Sizing Chart			
	Size 2	Size Three	Size Four
Proximal	size two	size three	size four
Distal	size zero (38ap/54ml)	size one	size two

APPENDIX 5: SIGMA REVISION ANTEROPOSTERIOR CHART (WITH SLEEVE USE)

The following chart shows the distance (mm) between the anterior flange of a femoral component and the sleeve, based on the size of the component and the anteroposterior option chosen. Fields with an X denote that the sleeve, femoral component and offset option is not possible.

		Femoral Size and A/P Position											
		1.5 Ant	1.5 Neut	1.5 Post	2 Ant	2 Neut	2 Post	2.5 Ant	2.5 Neut	2.5 Post	3 Ant	3 Neut	3 Post
Size of sleeve (M/L)	20 mm	0.9	2.7	4.7	1.8	3.8	5.8	2.6	4.6	6.6	3.2	5.2	7.2
	31 mm	2.1	4.5	5.8	2.7	5.0	7.0	3.8	5.8	7.8	4.6	6.7	8.6
	34 mm	X	3.4	4.6	2.1	4.4	5.9	3.2	5.2	7.0	3.6	5.7	7.6
	40 mm	X	2.4	3.9	1.2	3.2	5.6	2.0	3.9	6.0	2.7	4.6	6.5
	46 mm	X	2.6	3.6	X	2.6	4.8	1.5	3.6	5.5	2.4	4.6	6.4

		Femoral Size and A/P Position								
		4 Ant	4 Neut	4 Post	5 Ant	5 Neut	5 Post	6 Ant	6 Neut	6 Post
Size of sleeve (M/L)	20 mm	4.9	6.9	8.9	6.4	8.4	10.4	8.5	10.5	12.5
	31 mm	6.3	8.3	10.2	7.8	9.7	11.8	9.9	11.9	13.9
	34 mm	5.3	7.3	9.3	6.8	8.9	10.8	8.8	10.9	13.0
	40 mm	4.2	6.1	8.1	5.6	7.6	9.6	7.8	9.9	11.8
	46 mm	4.3	6.2	8.2	5.7	7.6	9.6	7.9	9.9	11.7

SIGMA HP REVISION FEMORAL PREP INSTRUMENT CASE CAT. NO. 2011-03-049

Top Tray

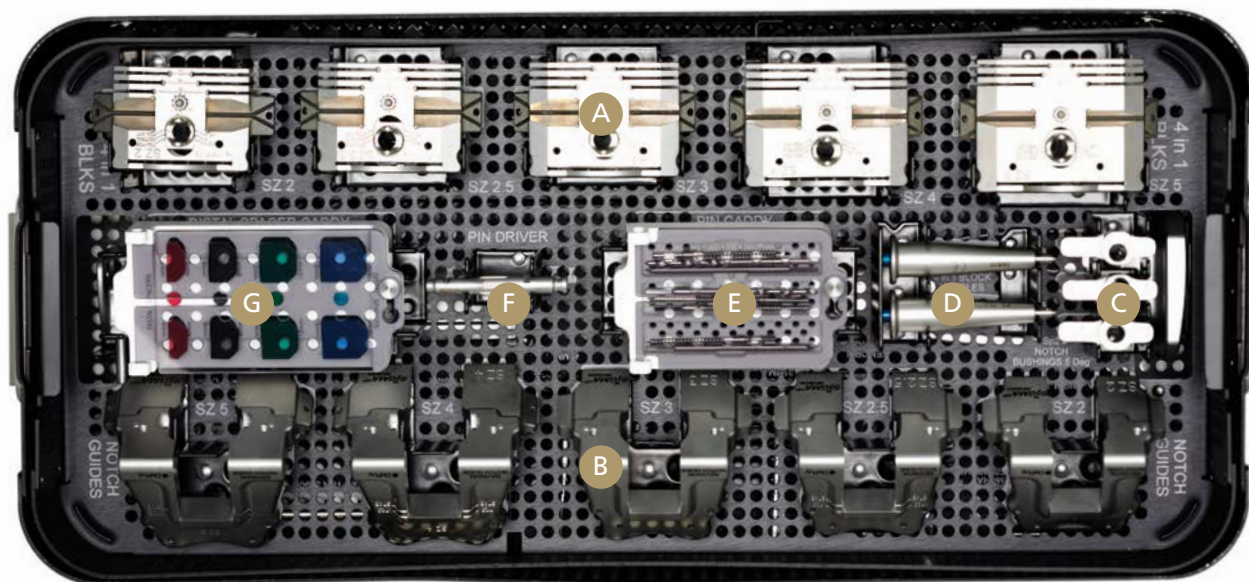

	Description	Cat. No.
A	SIGMA HP Revision 4-in-1 Cutting Block Size 2	2011-03-000
	SIGMA HP Revision 4-in-1 Cutting Block Size 2.5	2011-03-001
	SIGMA HP Revision 4-in-1 Cutting Block Size 3	2011-03-002
	SIGMA HP Revision 4-in-1 Cutting Block Size 4	2011-03-003
	SIGMA HP Revision 4-in-1 Cutting Block Size 5	2011-03-004
B	SIGMA HP Revision Notch Guide Size 2	2011-03-005
	SIGMA HP Revision Notch Guide Size 2.5	2011-03-006
	SIGMA HP Revision Notch Guide Size 3	2011-03-007
	SIGMA HP Revision Notch Guide Size 4	2011-03-008
	SIGMA HP Revision Notch Guide Size 5	2011-03-009
C	SP2 Femoral Notch Guide Bushing 5 degree +2L/-2R	96-6531
	SP2 Femoral Notch Guide Bushing 5 degree 0 mm offset	96-6532
	SP2 Femoral Notch Guide Bushing 5 degree +2R/-2L	96-6533
D	SP2 Removable Handles	96-6147
E	Pin Caddy	
F	SIGMA HP Power Pin Driver	9505-02-071
G	Distal Spacer Caddy	
	SIGMA HP Revision Distal Spacer 4 mm	2011-03-021
	SIGMA HP Revision Distal Spacer 8 mm	2011-03-022
	SIGMA HP Revision Distal Spacer 12 mm	2011-03-023
	SIGMA HP Revision Distal Spacer 16 mm	2011-03-024

SIGMA HP REVISION FEMORAL PREP INSTRUMENT CASE CAT. NO. 2011-03-049

Bottom Tray

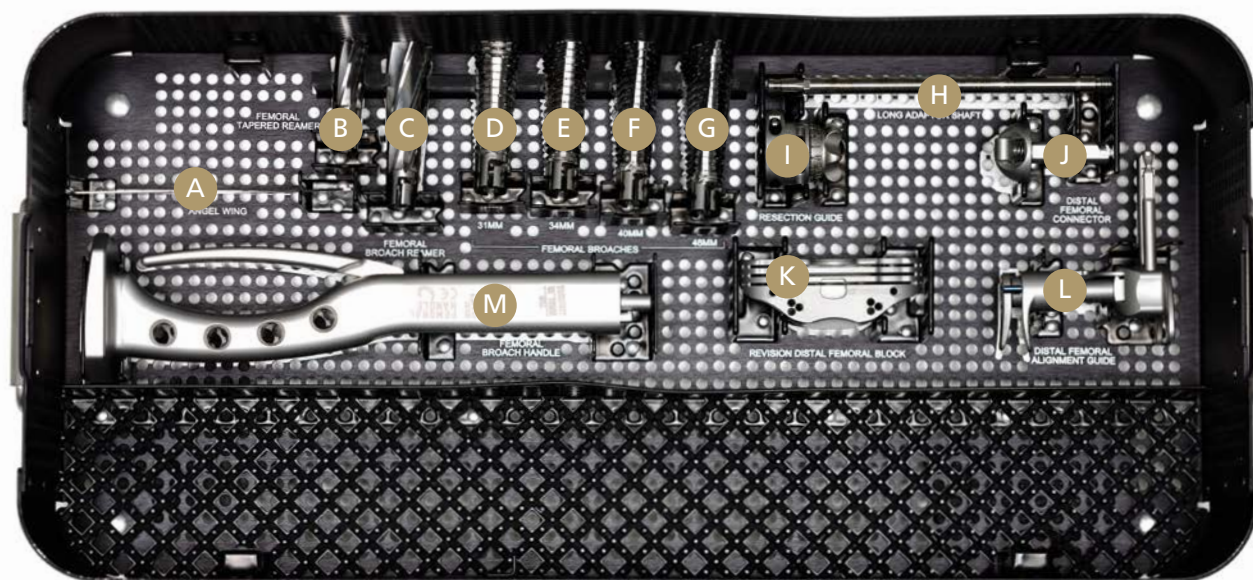

	Description	Cat. No.
A	Visualization Wing	96-6530
B	Completion Revision Femoral Tapered Reamer	2178-60-030
C	Universal Revision Femoral Broach Reamer	96-1671
D	Universal Revision Femoral Broach 31 mm	96-1683
E	Universal Revision Femoral Broach 34 mm	96-1684
F	Universal Revision Femoral Broach 40 mm	96-1685
G	Universal Revision Femoral Broach 46 mm	96-1686
H	SIGMA HP Revision Adapter Removable Shaft	2011-03-029
I	SIGMA HP Distal Femoral Resection Guide	9505-01-235
J	SIGMA HP Distal Femoral Connector	9505-01-238
K	SIGMA HP Revision Distal Femoral Block	9505-01-239
L	SIGMA HP Distal Femoral Alignment Guide	9505-01-234
M	Universal Revision Femoral Broach Handle	96-1682

SIGMA HP REVISION FEMORAL TRIAL INSTRUMENT CASE CAT. NO. 2011-03-050

Top Tray

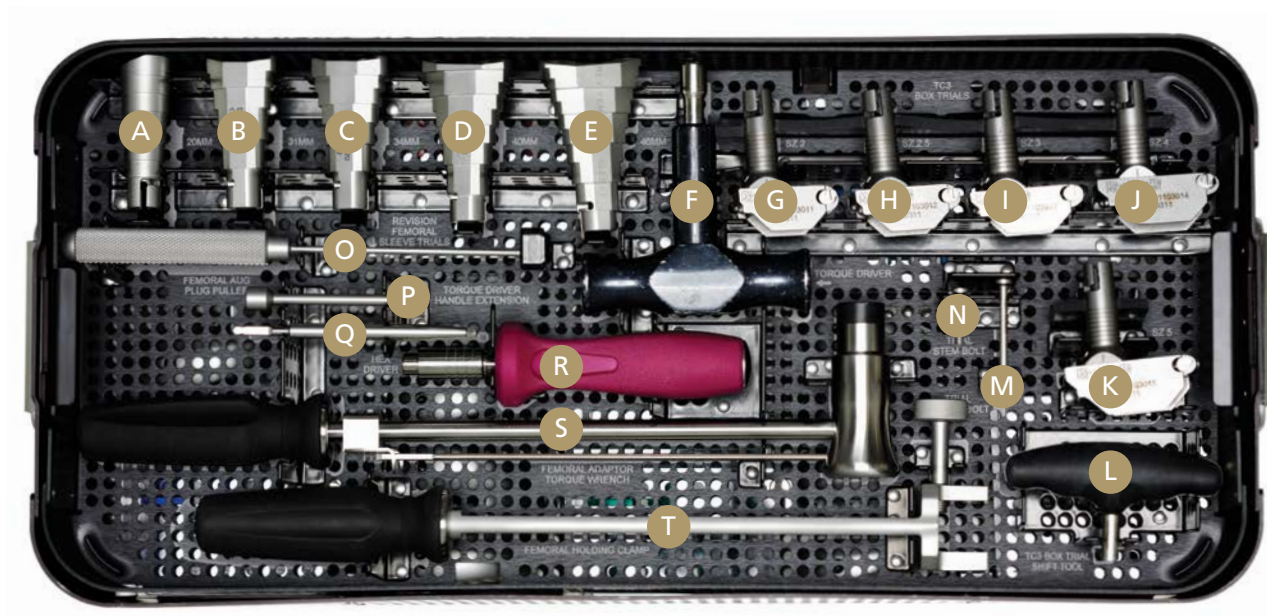

	Description	Cat. No.
A	LCS/SIGMA Revision Femoral Sleeve Trial 20 mm	2294-53-100
B	LCS/SIGMA Revision Femoral Sleeve Trial 31 mm	2294-53-110
C	LCS/SIGMA Revision Femoral Sleeve Trial 34 mm	2294-53-120
D	LCS/SIGMA Revision Femoral Sleeve Trial 40 mm	2294-53-130
E	LCS/SIGMA Revision Femoral Sleeve Trial 46 mm	2294-53-140
F	Modular Plus Torque Driver	86-0284
G	SIGMA HP Revision TC3 Box Trial Size 2	2011-03-011
H	SIGMA HP Revision TC3 Box Trial Size 2.5	2011-03-012
I	SIGMA HP Revision TC3 Box Trial Size 3	2011-03-013
J	SIGMA HP Revision TC3 Box Trial Size 4	2011-03-014
K	SIGMA HP Revision TC3 Box Trial Size 5	2011-03-015
L	SIGMA HP Revision Femoral Adapter Shift Tool	2011-03-057
M	SIGMA Femoral Adapter Sleeve Bolt Trial Neutral	2011-03-052
N	SIGMA Femoral Adapter Stem Bolt Trial Neutral	2011-03-051
O	Femoral Augment Plug Puller	86-5151
P	SP2 Torque Driver Handle Extension	96-6301
Q	Large Fragment Screwdriver Shank	8242-19-000
R	2.0 Nm Torque-limiting Screwdriver	2141-18-001
S	Femoral Adapter Torque Wrench	96-1673
T	Femoral Adapter Holding Clamp	96-1674

SIGMA HP REVISION FEMORAL TRIAL INSTRUMENT CASE CAT. NO. 2011-03-050

Bottom Tray

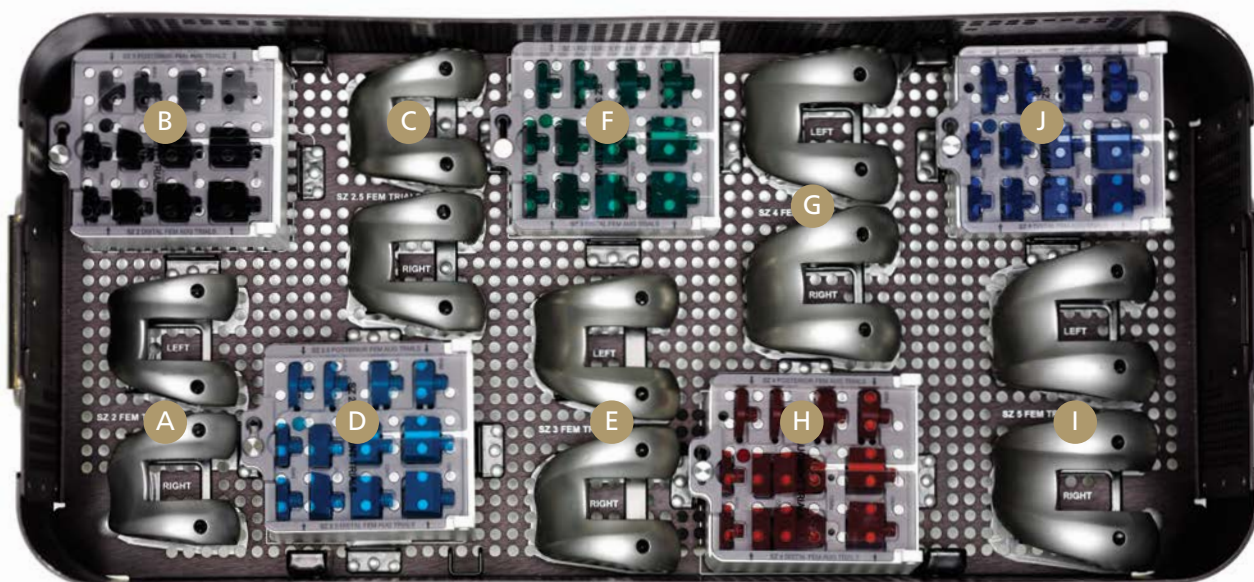

	Description	Cat. No
A	PFC SIGMA C/R Femoral Left Size 2 Trial	96-1002
	PFC SIGMA C/R Femoral Right Size 2 Trial	96-1012
B	Size 2 Femoral Augment Trial Caddy	
	PFC SIGMA Distal Femoral Augment Trial 4 mm Size 2	96-1820
	PFC SIGMA Distal Femoral Augment Trial 8 mm Size 2	96-1822
	PFC SIGMA Posterior Femoral Augment Trial 4 mm Size 2	96-1826
	PFC SIGMA Posterior Femoral Augment Trial 8 mm Size 2	96-1828
	PFC SIGMA Distal Femoral Augment Trial 12 mm Size 2	96-1830
	PFC SIGMA Distal Femoral Augment Trial 16 mm Size 2	96-1832
C	PFC SIGMA C/R Femoral Left Size 2.5 Trial	96-1008
	PFC SIGMA C/R Femoral Right Size 2.5 Trial	96-1018
D	Size 2.5 Femoral Augment Trial Caddy	
	PFC SIGMA Distal Femoral Augment Trial 4 mm Size 2.5	96-1840
	PFC SIGMA Distal Femoral Augment Trial 8 mm Size 2.5	96-1842
	PFC SIGMA Posterior Femoral Augment Trial 4 mm Size 2.5	96-1846
	PFC SIGMA Posterior Femoral Augment Trial 8 mm Size 2.5	96-1848
	PFC SIGMA Distal Femoral Augment Trial 12 mm Size 2.5	96-1850
	PFC SIGMA Distal Femoral Augment Trial 16 mm Size 2.5	96-1852
E	PFC SIGMA C/R Femoral Left Size 3 Trial	96-1003
	PFC SIGMA C/R Femoral Right Size 3 Trial	96-1013

SIGMA HP REVISION FEMORAL TRIAL CASE CAT. NO. 2011-03-050

Bottom Tray

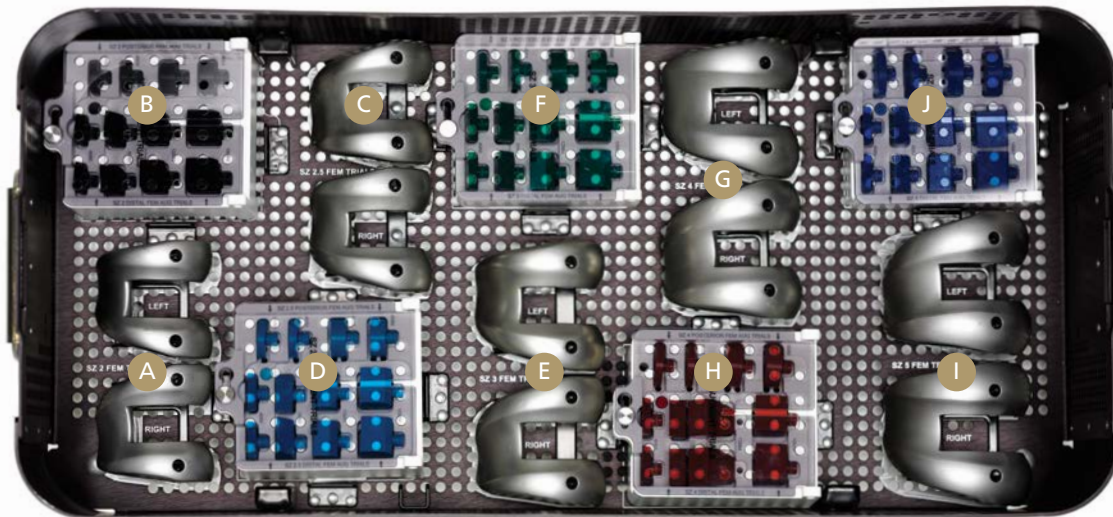

	Description	Cat. No
F	Size 3 Femoral Augment Trial Caddy	
	PFC SIGMA Distal Femoral Augment Trial 4 mm Size 3	96-1860
	PFC SIGMA Distal Femoral Augment Trial 8 mm Size 3	96-1862
	PFC SIGMA Posterior Femoral Augment Trial 4 mm Size 3	96-1866
	PFC SIGMA Posterior Femoral Augment Trial 8 mm Size 3	96-1868
	PFC SIGMA Distal Femoral Augment Trial 12 mm Size 3	96-1870
	PFC SIGMA Distal Femoral Augment Trial 16 mm Size 3	96-1872
G	PFC SIGMA C/R Femoral Left Size 4 Trial	96-1004
	PFC SIGMA C/R Femoral Right Size 4 Trial	96-1014
H	Size 4 Femoral Augment Trial Caddy	
	PFC SIGMA Distal Femoral Augment Trial 4 mm Size 4	96-1880
	PFC SIGMA Distal Femoral Augment Trial 8 mm Size 4	96-1882
	PFC SIGMA Posterior Femoral Augment Trial 4 mm Size 4	96-1886
	PFC SIGMA Posterior Femoral Augment Trial 8 mm Size 4	96-1888
	PFC SIGMA Distal Femoral Augment Trial 12 mm Size 4	96-1890
	PFC SIGMA Distal Femoral Augment Trial 16 mm Size 4	96-1892
I	PFC *SIGMA C/R Femoral Left Size 5 Trial	96-1005
	PFC SIGMA C/R Femoral Right Size 5 Trial	96-1015
J	Size 5 Femoral Augment Trial Caddy	
	PFC SIGMA Distal Femoral Augment Trial 4 mm Size 5	96-1900
	PFC SIGMA Distal Femoral Augment Trial 8 mm Size 5	96-1902
	PFC SIGMA Posterior Femoral Augment Trial 4 mm Size 5	96-1906
	PFC SIGMA Posterior Femoral Augment Trial 8 mm Size 5	96-1908
	PFC SIGMA Distal Femoral Augment Trial 12 mm Size 5	96-1910
	PFC SIGMA Distal Femoral Augment Trial 16 mm Size 5	96-1912

SIGMA HP REVISION TC3 RP INSERT TRIAL AND SPACER BLOCK CASE CAT. NO. 2011-03-070

Top Tray



	Description	Cat. No.
A	TC3 RP Tibial Insert Trial Size 2 10	96-3321
	TC3 RP Tibial Insert Trial Size 2 12.5	96-3322
	TC3 RP Tibial Insert Trial Size 2 15	96-3323
	TC3 RP Tibial Insert Trial Size 2 17.5	96-3324
	TC3 RP Tibial Insert Trial Size 2 20	96-3325
B	TC3 RP Tibial Insert Trial Size 2.5 10	96-3331
	TC3 RP Tibial Insert Trial Size 2.5 12.5	96-3332
	TC3 RP Tibial Insert Trial Size 2.5 15	96-3333
	TC3 RP Tibial Insert Trial Size 2.5 17.5	96-3334
	TC3 RP Tibial Insert Trial Size 2.5 20	96-3335
C	TC3 RP Tibial Insert Trial Size 3 10	96-3341
	TC3 RP Tibial Insert Trial Size 3 12.5	96-3342
	TC3 RP Tibial Insert Trial Size 3 15	96-3343
	TC3 RP Tibial Insert Trial Size 3 17.5	96-3344
	TC3 RP Tibial Insert Trial Size 3 20	96-3345
D	TC3 RP Tibial Insert Trial Size 4 10	96-3351
	TC3 RP Tibial Insert Trial Size 4 12.5	96-3352
	TC3 RP Tibial Insert Trial Size 4 15	96-3353
	TC3 RP Tibial Insert Trial Size 4 17.5	96-3354
	TC3 RP Tibial Insert Trial Size 4 20	96-3355
E	TC3 RP Tibial Insert Trial Size 5 10	96-3361
	TC3 RP Tibial Insert Trial Size 5 12.5	96-3362
	TC3 RP Tibial Insert Trial Size 5 15	96-3363
	TC3 RP Tibial Insert Trial Size 5 17.5	96-3364
	TC3 RP Tibial Insert Trial Size 5 20	96-3365

SIGMA HP REVISION TC3 RP INSERT TRIAL AND SPACER BLOCK CASE CAT. NO. 2011-03-070

Bottom Tray

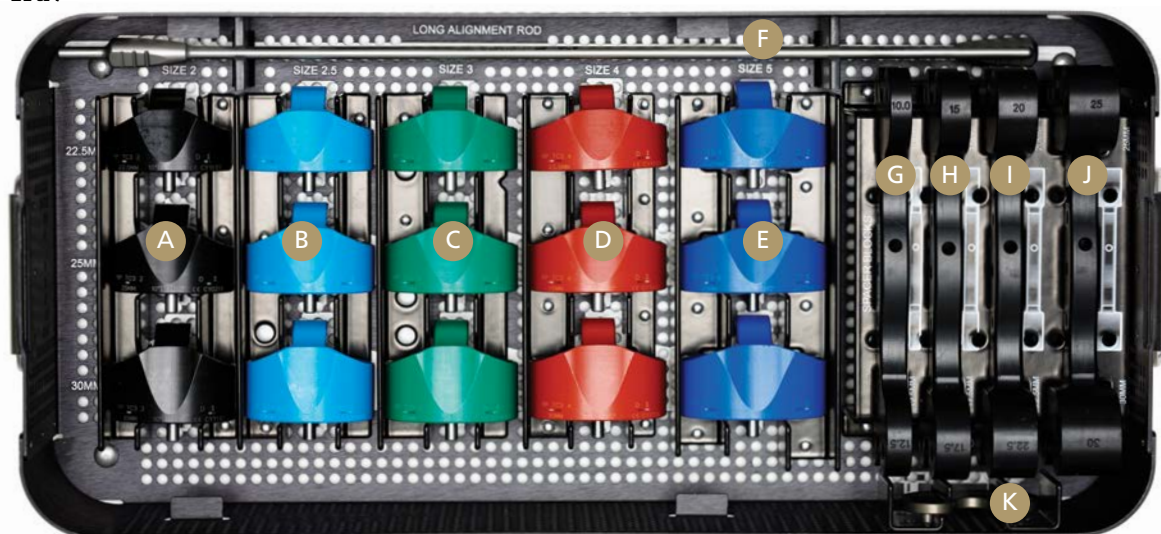

	Description	Cat. No.
A	TC3 RP Tibial Insert Trial Size 2 22.5	96-3326
	TC3 RP Tibial Insert Trial Size 2 25	96-3327
	TC3 RP Tibial Insert Trial Size 2 30	96-3328
B	TC3 RP Tibial Insert Trial Size 2.5 22.5	96-3336
	TC3 RP Tibial Insert Trial Size 2.5 25	96-3337
	TC3 RP Tibial Insert Trial Size 2.5 30	96-3338
C	TC3 RP Tibial Insert Trial Size 3 22.5	96-3346
	TC3 RP Tibial Insert Trial Size 3 25	96-3347
	TC3 RP Tibial Insert Trial Size 3 30	96-3348
D	TC3 RP Tibial Insert Trial Size 4 22.5	96-3356
	TC3 RP Tibial Insert Trial Size 4 25	96-3357
	TC3 RP Tibial Insert Trial Size 4 30	96-3358
E	TC3 RP Tibial Insert Trial Size 5 22.5	96-3366
	TC3 RP Tibial Insert Trial Size 5 25	96-3367
	TC3 RP Tibial Insert Trial Size 5 30	96-3368
F	HP Alignment Rod	9505-01-207
G	SIGMA HP Revision M.B.T. Spacer Block 10/12.5	2011-03-017
H	SIGMA HP Revision M.B.T. Spacer Block 15/17.5	2011-03-018
I	SIGMA HP Revision M.B.T. Spacer Block 20/22.5	2011-03-019
J	SIGMA HP Revision M.B.T. Spacer Block 25/30	2011-03-020
K	SIGMA HP Revision Extension Shim	2011-03-061

M.B.T. REVISION PREPARATION CASE

CAT. NO. 2178-64-100

Top Tray

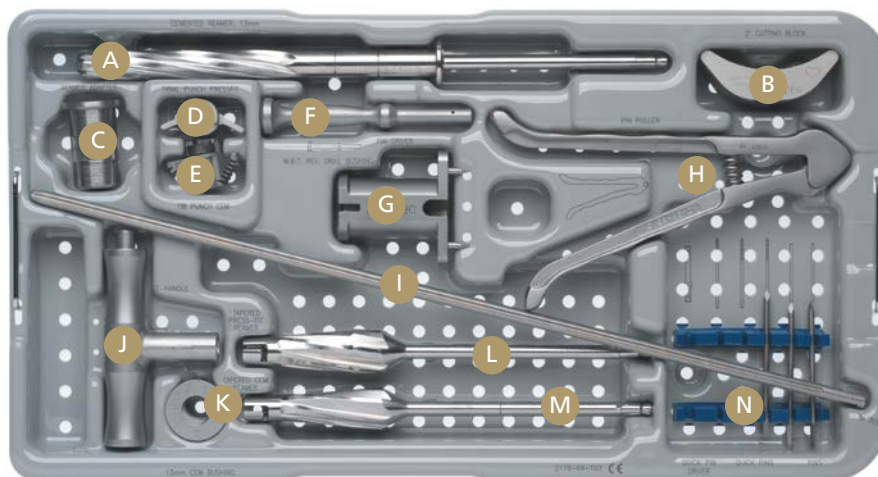

	Description	Cat. No.
A	M.B.T. Revision Cemented Stem Reamer, 13 mm	2178-63-185
B	Tibial Cutting Block, 2 Degree	2178-40-086
C	M.B.T Revision Reamer Adapter	2178-63-128
D	M.B.T. Revision Press-fit Tibial Punch	2178-63-118
E	M.B.T. Revision Cemented Tibial Punch	2178-63-120
F	Pin Driver	2490-94-000
G	M.B.T. Revision Drill Bushing	2178-63-100
H	Pin Puller	96-6515
I	SP2 IM Rod, 400 mm	96-6120
J	SP2 IM Rod Handle	99-2011
K	M.B.T. Revision Cemented Bushing, 13 mm	2178-63-196
L	M.B.T. Revision Tapered Press-fit Reamer	2178-63-104
M	M.B.T. Revision Tapered Cemented Reamer	2178-63-106
N	Steinman Pins (Package of 10)	86-9117

M.B.T. REVISION PREPARATION CASE

CAT. NO. 2178-64-100

Bottom Tray



	Description	Cat. No.
A	M.B.T. Revision 2-Degree Tibial Broaches 29 mm	2178-63-109
	M.B.T. Revision 2-Degree Tibial Broaches 37 mm	2178-63-111
	M.B.T. Revision 2-Degree Tibial Broaches 45 mm	2178-63-113
	M.B.T. Revision 2-Degree Tibial Broaches 53 mm	2178-63-115
	M.B.T. Revision 2-Degree Tibial Broaches 61 mm	2178-63-117
B	M.B.T. Tray Sleeve Trials 29 mm	2294-54-000
	M.B.T. Tray Sleeve Trials 37 mm	2294-54-100
	M.B.T. Tray Sleeve Trials 45 mm	2294-54-110
	M.B.T. Tray Sleeve Trials 53 mm	2294-54-120
	M.B.T. Tray Sleeve Trials 61 mm	2294-54-130
C	LCS Completion Tibial Stylus	2178-40-045
D	M.B.T. Revision Tibial Broach Handle	96-6521
E	Revision Sleeve Impactor	2178-63-124
F	Revision Femoral Sleeve/Stem Impactor	2178-63-126
G	SP2 Universal Handle	96-6520
H	SP2 IM Tibial Alignment Device	96-6315
I	M.B.T. Tibial Impactor	9505-01-558
J	M.B.T. Revision Tibial View Plate, Size 1	2178-65-110
	M.B.T. Revision Tibial View Plate, Size 1.5	2178-65-115
	M.B.T. Revision Tibial View Plate, Size 2	2178-65-120
	M.B.T. Revision Tibial View Plate, Size 2.5	2178-65-125
	M.B.T. Revision Tibial View Plate, Size 3	2178-65-130
	M.B.T. Revision Tibial View Plate, Size 4	2178-65-140
	M.B.T. Revision Tibial View Plate, Size 5	2178-65-150
	M.B.T. Revision Tibial View Plate, Size 6	2178-65-160

M.B.T. REVISION STEM TRIALS AND INSTRUMENTS CASE CAT. NO. 2178-64-110

Top Tray



	Description	Cat. No.
A	Revision Femoral/Tibial Sleeve Clamp	2178-63-134
B	SIGMA Tibial Cemented Stem Trial, Sizes 2-3, 13 x 60 mm	86-6502
C	SIGMA Tibial Cemented Stem Trial, Sizes 1.5-3, 13 x 30 mm	86-6501
D	Stem Trial Extractor	86-5226
E	Fluted Tibial Stem Trials – 75 mm	
	75 x 10 mm	86-6874
	75 x 12 mm	86-6875
	75 x 14 mm	86-6876
	75 x 16 mm	86-6877
	75 x 18 mm	86-6878
	75 x 20 mm	86-6879
	75 x 22 mm	86-6880
	75 x 24 mm	86-6881

M.B.T. REVISION STEM TRIALS AND INSTRUMENTS

CASE CAT. NO. 2178-64-110

Top Tray



	Description	Cat. No.
F	Fluted Tibial Stem Trials – 115 mm	
	115 x 10 mm	86-6882
	115 x 12 mm	86-6883
	115 x 14 mm	86-6884
	115 x 16 mm	86-6885
	115 x 18 mm	86-6886
	115 x 20 mm	86-6887
	115 x 22 mm	86-6888
	115 x 24 mm	86-6889
G	Fluted Tibial Stem Trials – 150 mm	
	150 x 10 mm	86-6890
	150 x 12 mm	86-6891
	150 x 14 mm	86-6892
	150 x 16 mm	86-6893
	150 x 18 mm	86-6894
	150 x 20 mm	86-6895
	150 x 22 mm	86-6896
	150 x 24 mm	86-6897

M.B.T. REVISION STEM TRIALS AND INSTRUMENTS

CASE CAT. NO. 2178-64-110

Bottom Tray



	Description	Cat. No.
A	Press-fit Rod Wrench	86-5189
B	SIGMA Tibial Cemented Stem Trial, Sizes 2-3, 13 x 60 mm	86-6502
C	SIGMA Tibial Cemented Stem Trial, Sizes 1.5-3, 13 x 30 mm	86-6501
D	Fluted Tibial Stem Trials – 75 mm	
	75 x 10 mm	86-6874
	75 x 12 mm	86-6875
	75 x 14 mm	86-6876
	75 x 16 mm	86-6877
	75 x 18 mm	86-6878
	75 x 20 mm	86-6879
	75 x 22 mm	86-6880
	75 x 24 mm	86-6881

M.B.T. REVISION STEM TRIALS AND INSTRUMENTS CASE CAT. NO. 2178-64-110

Bottom Tray



	Description	Cat. No.
E	Fluted Tibial Stem Trials – 115 mm	
	115 x 10 mm	86-6882
	115 x 12 mm	86-6883
	115 x 14 mm	86-6884
	115 x 16 mm	86-6885
	115 x 18 mm	86-6886
	115 x 20 mm	86-6887
	115 x 22 mm	86-6888
	115 x 24 mm	86-6889
F	Fluted Tibial Stem Trials – 150 mm	
	150 x 10 mm	86-6890
	150 x 12 mm	86-6891
	150 x 14 mm	86-6892
	150 x 16 mm	86-6893
	150 x 18 mm	86-6894
	150 x 20 mm	86-6895
	150 x 22 mm	86-6896
	150 x 24 mm	86-6897

M.B.T. REVISION REAMERS CASE

CAT. NO. 2178-64-105

Top Tray



	Description	Cat. No.
A	Press-fit Rod Wrench	86-5189
B	IM Rod Sleeve Guide, 12 mm	2178-63-187
C	IM Rod Sleeve Guide, 14 mm	2178-63-188
D	LCS Reamer Depth Scale	2178-63-102
E	Revision Femoral/Tibial/Sleeve Clamp	2178-63-134
F	I.M. Reamer, 9 mm	2178-56-045
G	M.B.T. Revision Reamers	
	M.B.T. Revision Reamer, 10 mm	2178-63-170
	M.B.T. Revision Reamer, 11 mm	2178-63-171
	M.B.T. Revision Reamer, 12 mm	2178-63-172
	M.B.T. Revision Reamer, 13 mm	2178-63-173
	M.B.T. Revision Reamer, 14 mm	2178-63-174
	M.B.T. Revision Reamer, 15 mm	2178-63-175

M.B.T. REVISION REAMERS CASE

CAT. NO. 2178-64-105

Bottom Tray



	Description	Cat. No.
A	M.B.T. Revision Reamers	
	M.B.T. Revision Reamer, 16 mm	2178-63-176
	M.B.T. Revision Reamer, 17 mm	2178-63-177
	M.B.T. Revision Reamer, 18 mm	2178-63-178
	M.B.T. Revision Reamer, 19 mm	2178-63-179
	M.B.T. Revision Reamer, 20 mm	2178-63-180
	M.B.T. Revision Reamer, 21 mm	2178-63-181
	M.B.T. Revision Reamer, 22 mm	2178-63-182
	M.B.T. Revision Reamer, 23 mm	2178-63-183
	M.B.T. Revision Reamer, 24 mm	2178-63-184
B	IM Rod Sleeve Guide, 16 mm	2178-63-189
C	IM Rod Sleeve Guide, 18 mm	2178-63-190
D	IM Rod Sleeve Guide, 20 mm	2178-63-
E	IM Rod Sleeve Guide, 22 mm	2178-63-192
F	IM Rod Sleeve Guide, 24 mm	2178-63-193
G	IM Rod Sleeve Guide, 26 mm	2178-63-194
H	M.B.T. Revision T-Handle	2178-63-137
I	Modified Hudson Adapter	2178-63-136

M.B.T. REVISION WEDGE TRIALS AND INSTRUMENTS CAT. NO. 2178-64-115

Top Tray



	Description	Cat. No.
A	Size 1, 5 mm	2294-56-110
	Size 1, 10 mm	2294-56-111
	Size 1, 15 mm	2294-56-112
B	Size 1.5, 5 mm	2294-56-115
	Size 1.5, 10 mm	2294-56-116
	Size 1.5, 15 mm	2294-56-117
C	Size 2, 5 mm	2294-56-120
	Size 2, 10 mm	2294-56-121
	Size 2, 15 mm	2294-56-122
D	Size 2.5, 5 mm	2294-56-125
	Size 2.5, 10 mm	2294-56-126
	Size 2.5, 15 mm	2294-56-127
E	Size 3, 5 mm	2294-56-130
	Size 3, 10 mm	2294-56-131
	Size 3, 15 mm	2294-56-132
F	Size 4, 5 mm	2294-56-135
	Size 4, 10 mm	2294-56-136
	Size 4, 15 mm	2294-56-137
G	Size 5, 5 mm	2294-56-140
	Size 5, 10 mm	2294-56-141
	Size 5, 15 mm	2294-56-142
H	Size 6/7, 5 mm	2294-56-145
	Size 6/7, 10 mm	2294-56-146
	Size 6/7, 15 mm	2294-56-147

M.B.T. REVISION WEDGE TRIALS AND INSTRUMENTS

CAT. NO. 2178-64-115

Bottom Tray

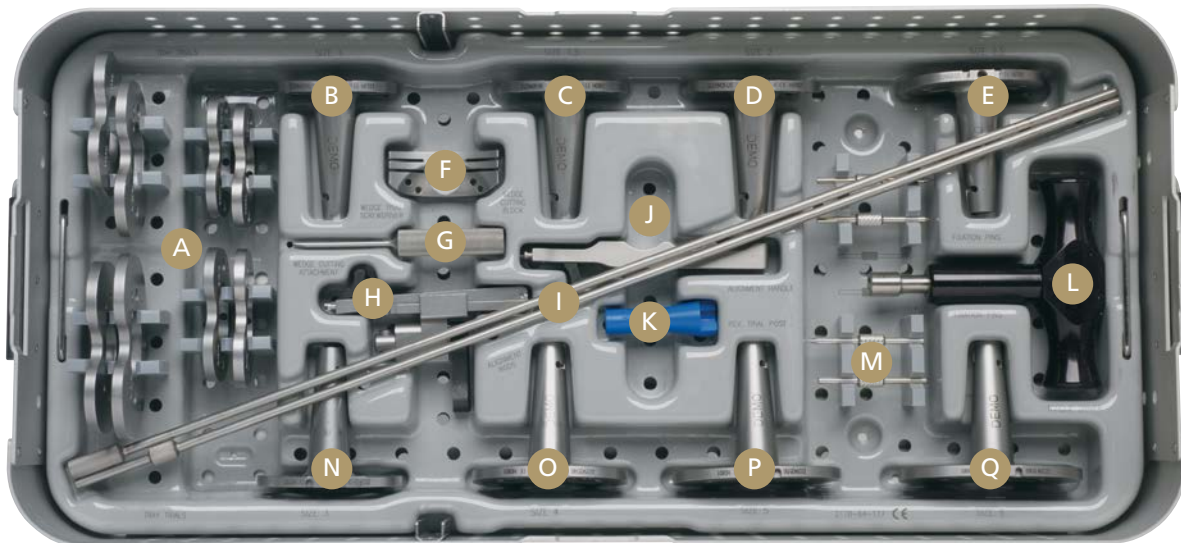

	Description	Cat. No.
A	M.B.T. Revision Tray Trial, Size 1	2294-36-110
	M.B.T. Revision Tray Trial, Size 1.5	2294-36-115
	M.B.T. Revision Tray Trial, Size 2	2294-36-120
	M.B.T. Revision Tray Trial, Size 2.5	2294-36-125
	M.B.T. Revision Tray Trial, Size 3	2294-36-130
	M.B.T. Revision Tray Trial, Size 4	2294-36-140
	M.B.T. Revision Tray Trial, Size 5	2294-36-150
	M.B.T. Revision Tray Trial, Size 6	2294-36-160
B	M.B.T. Revision Tray Trial with Stem, Size 1	2294-35-110
C	M.B.T. Revision Tray Trial with Stem, Size 1.5	2294-35-115
D	M.B.T. Revision Tray Trial with Stem, Size 2	2294-35-120
E	M.B.T. Revision Tray Trial with Stem, Size 2.5	2294-35-125
F	M.B.T. Revision Cutting Block	2178-63-122
G	Tibial Wedge Trial Screwdriver	86-0277
H	M.B.T. Wedge Cutting Attachment	2178-63-130
I	SP2 Alignment Rods	99-1016
J	Tibial Trial Alignment Handle	96-6330
K	M.B.T. Revision Trial Post	2178-63-132
L	Modular Plus Torque Driver	86-0284
M	M.B.T. Tray Trial Fixation Pins	2178-30-123
N	M.B.T. Revision Tray Trial with Stem, Size 3	2294-35-130
O	M.B.T. Revision Tray Trial with Stem, Size 4	2294-35-140
P	M.B.T. Revision Tray Trial with Stem, Size 5	2294-35-150
Q	M.B.T. Revision Tray Trial with Stem, Size 6	2294-35-160







COMPANIES OF *Johnson & Johnson*

DePuy Orthopaedics, Inc.
700 Orthopaedic Drive
Warsaw, IN 46582
T. +1 (800) 366-8143

www.depuysynthes.com

0612-51-506 (Rev. 5) 3M 10/13