



ESP8266EX Hardware User Guide

Version 1.1

Espressif Systems IOT Team

<http://bbs.espressif.com>

Copyright © 2015



Disclaimer and Copyright Notice

Information in this document, including URL references, is subject to change without notice.

THIS DOCUMENT IS PROVIDED AS IS WITH NO WARRANTIES WHATSOEVER, INCLUDING ANY WARRANTY OF MERCHANTABILITY, NON-INFRINGEMENT, FITNESS FOR ANY PARTICULAR PURPOSE, OR ANY WARRANTY OTHERWISE ARISING OUT OF ANY PROPOSAL, SPECIFICATION OR SAMPLE. All liability, including liability for infringement of any proprietary rights, relating to use of information in this document is disclaimed. No licenses express or implied, by estoppel or otherwise, to any intellectual property rights are granted herein.

The WiFi Alliance Member Logo is a trademark of the WiFi Alliance.

All trade names, trademarks and registered trademarks mentioned in this document are property of their respective owners, and are hereby acknowledged.

Copyright © 2015 Espressif Systems (Shanghai) Pte. Ltd. All rights reserved.



Table of Contents

- 1. General Overview5**
 - 1.1. Introduction.....5
 - 1.2. Features6
 - 1.3. Parameters.....7
 - 1.4. Major Applications8

- 2. Hardware Overview9**
 - 2.1. Terminal Configuration and Functions9
 - 2.2. Schematics12
 - 2.2.1. Power-supply Pins13
 - 2.2.2. Power-on Sequence and Power Reset.....14
 - 2.2.3. Flash15
 - 2.2.4. Crystal Oscillator15
 - 2.2.5. RF.....16
 - 2.2.6. External Resistor 12K.....17
 - 2.3. Layout Design17
 - 2.3.1. ESP-WROOM Module Design17
 - 2.3.2. ESP8266EX as Slave Device20
 - 2.3.3. FAQ On Hardware Design22

- 3. ESP-LAUNCHER Development Board24**
 - 3.1. Instructions on the Use of ESP-LAUNCHER Development Board25
 - 3.2. Pin Definitions of ESP-LAUNCHER Development Board28
 - 3.3. Typical Applications Using ESP-LAUNCHER31
 - 3.3.1. ESP-LAUNCHER Test Board.....31
 - 3.3.2. SMD Module ESP-WROOM-02.....31
 - 3.3.3. DIP Module ESP-WROOM-0135

- 4. Compiling, Downloading, and Debugging.....36**
 - 4.1. Set Up the Compiling Environment36
 - 4.2. Download Firmware38
 - 4.3. Debugging AT Commands via UART38



- 5. Typical Applications.....40**
 - 5.1. WiFi smart hardware converted from UART serial ports40
 - 5.2. Sensor.....40
 - 5.3. Smart light.....40
 - 5.4. Smart plug41

- 6. Appendix.....42**
 - 6.1. Schematics of ESP-LAUNCHER Development Board42
 - Part 1: Interfaces43
 - Part 2: 5V Power46
 - Part 3: Test Board46
 - 6.2. Schematics of ESP-LAUNCHER Test Board46
 - 6.3. Schematics of ESP-WROOM Serial WiFi Modules.....47
 - 6.4. Schematics of ESP8266EX as SDIO/SPI Slave Device48

1. General Overview

1.1. Introduction

Espressif Systems' Smart Connectivity Platform (ESCP) is a set of high performance, high integration wireless SOCs, designed for space and power constrained mobile platform designers. It provides unsurpassed ability to embed Wi-Fi capabilities within other systems, or to function as a standalone application, with the lowest cost, and minimal space requirement.

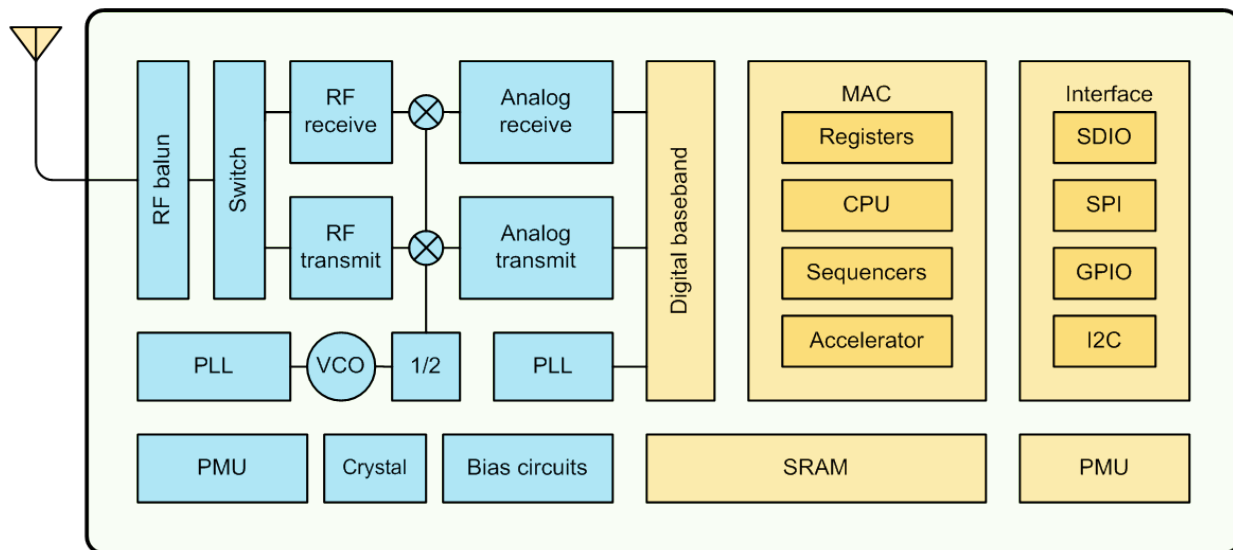

Figure 1 ESP8266EX Block Diagram

ESP8266EX offers a complete and self-contained Wi-Fi networking solution; it can be used to host the application or to offload Wi-Fi networking functions from another application processor.

When ESP8266EX hosts the application, it boots up directly from an external flash. It has integrated cache to improve the performance of the system in such applications.

Alternately, serving as a Wi-Fi adapter, wireless internet access can be added to any micro controller-based design with simple connectivity (SPI/SDIO or I2C/UART interface).

ESP8266EX is among the most integrated WiFi chip in the industry; it integrates the antenna switches, RF balun, power amplifier, low noise receive amplifier, filters, power management modules, it requires minimal external circuitry, and the entire solution, including front-end module, is designed to occupy minimal PCB area.



ESP8266EX also integrates an enhanced version of Tensilica's L106 Diamond series 32-bit processor, with on-chip SRAM, besides the Wi-Fi functionalities. ESP8266EX is often integrated with external sensors and other application specific devices through its GPIOs; sample codes for such applications are provided in the software development kit (SDK).

Espressif Systems' Smart Connectivity Platform (ESCP) demonstrates sophisticated system-level features include fast switching between sleep and wake-up mode for energy-efficiency purpose, adaptive radio biasing for low-power operation, advance signal processing, and spur cancellation and radio co-existence features for common cellular, Bluetooth, DDR, LVDS, LCD interference mitigation.

1.2. Features

- 802.11 b/g/n
- Integrated low power 32-bit MCU
- Integrated 10-bit ADC
- Integrated TCP/IP protocol stack
- Integrated TR switch, balun, LNA, power amplifier and matching network
- Integrated PLL, regulators, and power management units
- Supports antenna diversity
- Wi-Fi 2.4 GHz, support WPA/WPA2
- Support STA/AP/STA+AP operation modes
- Support Smart Link Function for both Android and iOS devices
- SDIO 2.0, (H) SPI, UART, I2C, I2S, IR Remote Control, PWM, GPIO
- A-MPDU & A-MSDU aggregation & 0.4s guard interval
- Deep sleep power <10uA, Power down leakage current < 5uA
- Wake up and transmit packets in < 2ms
- Standby power consumption of < 1.0mW (DTIM3)
- +20 dBm output power in 802.11b mode
- Operating temperature range -40C ~ 125C
- FCC, CE, TELEC, Wi-Fi Alliance, and SRRC certified



1.3. Parameters

Categories	Items	Values
WiFi Paramters	Certificates	FCC/CE/TELEC/SRRC
	WiFi Protocles	802.11 b/g/n
	Frequency Range	2.4G-2.5G (2400M-2483.5M)
	Tx Power	802.11 b: +20 dBm
		802.11 g: +17 dBm
		802.11 n: +14 dBm
	Rx Sensitivity	802.11 b: -91 dbm (11 Mbps)
802.11 g: -75 dbm (54 Mbps)		
802.11 n: -72 dbm (MCS7)		
Types of Antenna	PCB Trace, External, IPEX Connector, Ceramic Chip	
Hardware Paramaters	Peripheral Bus	UART/SDIO/SPI/I2C/I2S/IR Remote Control
		GPIO/PWM
	Operating Voltage	3.0~3.6V
	Operating Current	Average value: 80mA
	Operating Temperature Range	-40°~125°
	Ambient Temperature Range	Normal temperature
	Package Size	5x5mm
External Interface	N/A	
Software Parameters	Wi-Fi mode	station/softAP/SoftAP+station
	Security	WPA/WPA2
	Encryption	WEP/TKIP/AES
	Firmware Upgrade	UART Download / OTA (via network)
	Ssoftware Development	Supports Cloud Server Development / SDK for custom firmware development
	Network Protocols	IPv4, TCP/UDP/HTTP/FTP



Categories	Items	Values
Software Parameters	User Configuration	AT Instruction Set, Cloud Server, Android/iOS App

Table 1 Parameters of ESP8266EX

1.4. Major Applications

Major fields of ESP8266EX applications to Internet-of-Things include:

- Home Appliances
- Home Automation
- Smart Plug and lights
- Mesh Network
- Industrial Wireless Control
- Baby Monitors
- IP Cameras
- Sensor Networks
- Wearable Electronics
- Wi-Fi Location-aware Devices
- Security ID Tags
- Wi-Fi Position System Beacons



Pin	Name	Type	Function
1	VDDA	P	Analog Power 3.0 ~3.6V
2	LNA	I/O	RF Antenna Interface, Chip Output Impedance=50Ω No matching required but we recommend that the n-type matching network is retained.
3	VDD3P3	P	Amplifier Power 3.0~3.6V
4	VDD3P3	P	Amplifier Power 3.0~3.6V
5	VDD_RTC	P	NC(1.1V)
6	TOUT	I	ADC Pin
7	CHIP_EN	I	Chip Enable. High: On, chip works properly; Low: Off, small current
8	XPD_DCDC	I/O	Deep-Sleep Wakeup; GPIO16
9	MTMS	I/O	GPIO14; HSPI_CLK
10	MTDI	I/O	GPIO12; HSPI_MISO
11	VDDPST	P	Digital/IO Power Supply (1.8V~3.3V)
12	MTCK	I/O	GPIO13; HSPI_MOSI; UART0_CTS
13	MTDO	I/O	GPIO15; HSPI_CS; UART0_RTS
14	GPIO2	I/O	UART Tx during flash programming; GPIO2
15	GPIO0	I/O	GPIO0; SPI_CS2
16	GPIO4	I/O	GPIO4
17	VDDPST	P	Digital/IO Power Supply (1.8V~3.3V)
18	SDIO_DATA_2	I/O	Connect to SD_D2 (Series R: 200Ω); SPIHD; HSPIHD; GPIO9
19	SDIO_DATA_3	I/O	Connect to SD_D3 (Series R: 200Ω); SPIWP; HSPIWP; GPIO10
20	SDIO_CMD	I/O	Connect to SD_CMD (Series R: 200Ω); SPI_CS0; GPIO11
21	SDIO_CLK	I/O	Connect to SD_CLK (Series R: 200Ω); SPI_CLK; GPIO6
22	SDIO_DATA_0	I/O	Connect to SD_D0 (Series R: 200Ω); SPI_MSIO; GPIO7
23	SDIO_DATA_1	I/O	Connect to SD_D1 (Series R: 200Ω); SPI_MOSI; GPIO8



Pin	Name	Type	Function
24	GPIO5	I/O	GPIO5
25	U0RXD	I/O	UART Rx during flash programming; GPIO3
26	U0TXD	I/O	UART Tx during flash programming; GPIO1; SPI_CS1
27	XTAL_OUT	I/O	Connect to crystal oscillator output, can be used to provide BT clock input
28	XTAL_IN	I/O	Connect to crystal oscillator input
29	VDDD	P	Analog Power 3.0V~3.6V
30	VDDA	P	Analog Power 3.0V~3.6V
31	RES12K	I	Serial connection with a 12 kΩ resistor and connect to the ground
32	EXT_RSTB	I	External reset signal (Low voltage level: Active)

Table 2 Attributes and Functions of Pins

Note: GPIO2, GPIO0, MTDO can be configurable as 3-bit SDIO mode.

2.2. Schematics

ESP8266EX is very highly integrated SoC which encapsulates Transilica LX106 core processor, RAM, RF components and allow WiFi TCP/IP stack to be implemented on board with just few components beside ESP8266. The chipset also incorporates built-in self-calibration to compensate for performance errors, improving the modulation accuracy and stability of wireless communications.

High integration level of this chipset tremendously decreases the number of components used in peripheral circuit design. Beside ESP8266EX, only a number of less than 10 resistors and capacitors, one crystal oscillator, and one SPI Flash is needed to make a complete module with wireless communication capability. A detailed description of ESP8266EX schematics and layout design are illustrated here.

The complete circuit diagram of ESP8266EX is illustrated in Figure 3:

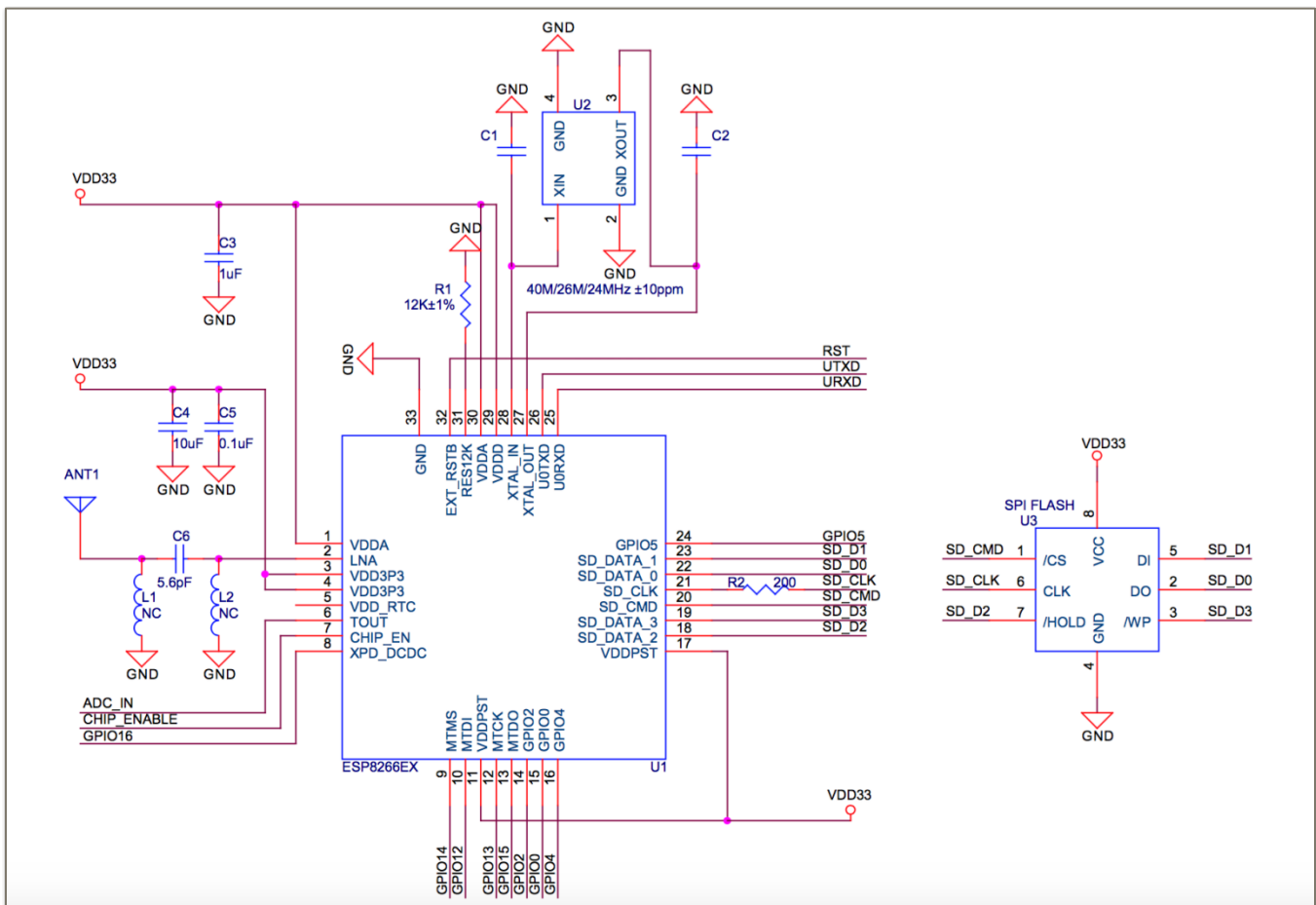

Figure 3 ESP8266EX Schematics



ESP8266EX SCH design covers the following five parts:

- Power supply;
- Power on sequence and reset;
- Flash;
- Crystal oscillator;
- RF.

2.2.1. Power-supply Pins

Digital Power-supply Pins

ESP8266EX has only two digital power-supply pins (abbreviated as VDDPST in the circuit diagram), Pin11 and Pin17. In digital power supply, there is no need to add additional filter capacitors. The operating voltage range of digital power-supply pins is between 1.8V and 3.3V.

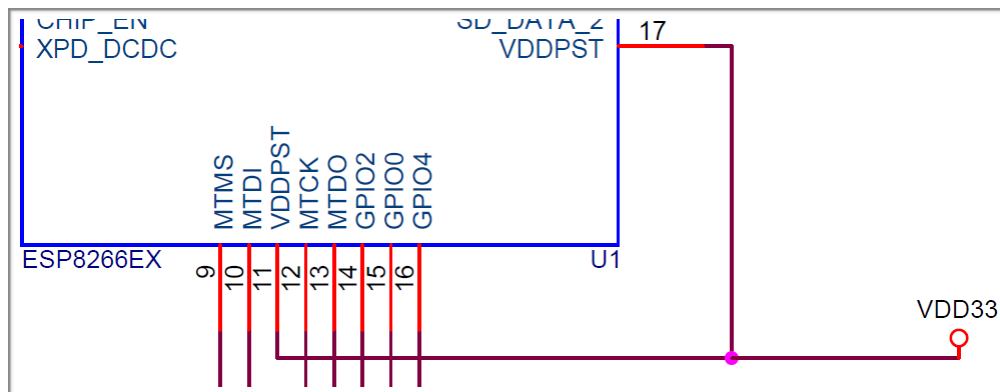

Figure 4 ESP8266EX Digital Power-supply Pins

Analog Power-supply Pins

ESP8266EX has 5 analog power-supply pins (abbreviated as VDD33 in the circuit diagram), including Pin 1, Pin 3, Pin 4, which provides internal power supply for internal PA and LNA respectively, and Pin 28, Pin 29, which supplies power for internal PLL. The operating voltage range of the analog power-supply pins is between 1.8V and 3.3V.

It should be noted that the power supply channel might be damaged due to the sudden increase of current when ESP8266EX is transmitting analog signals. Therefore, an additional 0.1uF capacitor with



a package size of 0603 or 0805 is needed in circuit design. This capacitor can be used in 0.1uF in match with capacitor with 0.1uF capacitor with 0402 package.

(Notes: There is no need to add magnetic beads in the design of analog power-supply circuit, for ESP8266EX's EMC is in conformity with FCC and CE requirements, and has been approved.)

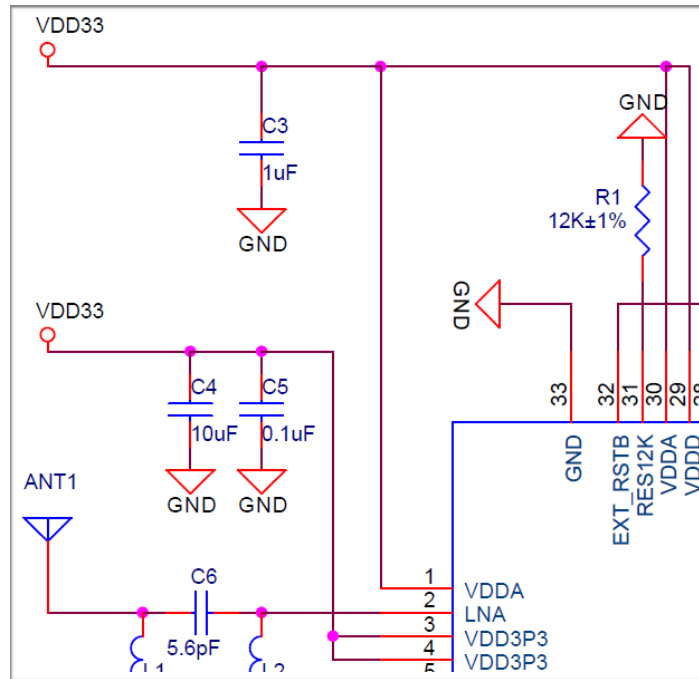

Figure 5 ESP8266EX AVDD

2.2.2. Power-on Sequence and Power Reset

Power-on sequence

The voltage of the chipset's WiFi power supply systems is 3.3V, therefore only one rule should be abide by when you power on the device: Pin7 CH_EN, the power enable pin, should be powered on at the same time when or after the power supply system is powered on.

Note: If the power management IC is connected with the power-on enable pin CHIP_EN, it can control the power on-and-off of ESP8266EX by output high and low voltage through its GPIOs. However, pulsed current might be produced at the same time. In order to delay the transmission of pulsed signal and avoid unstable current of CHIP_EN, a RC time-delay circuit (R=1kΩ, C=100nF) is needed. There is an internal pull-up in the CHIP_EN pin, so no external pull-up is needed.



Reset

There exists internal pull-up resistor in the reset pin, Pin32, which can be left dangled when it is not used. When the chip is enabled, the reset pin is held low. In order to avoid reset caused by external interference, the lead is generally required to be short, and no external pull-up resistor is necessary.

The enable pin CH_EN (pin 7) can also serve as a reset pin. If voltage for CH_EN pin is low, the chipset ESP8266EX will power off. Note that this pin cannot be dangled.

2.2.3. Flash

Currently, the size of flash that we applied in our demo and modules is SPI Flash with 2MB capacity, and the package size is SOIC_8 (SOP_8).

A resistor (package size: 0402) is connected to Pin21, the SD_CLK pin via serial port, with the aim to lower the driving current, decrease cross-talk and external interruption, adjust the sequence, and so on. The initial value of the serial connection resistor is 200 ohm.

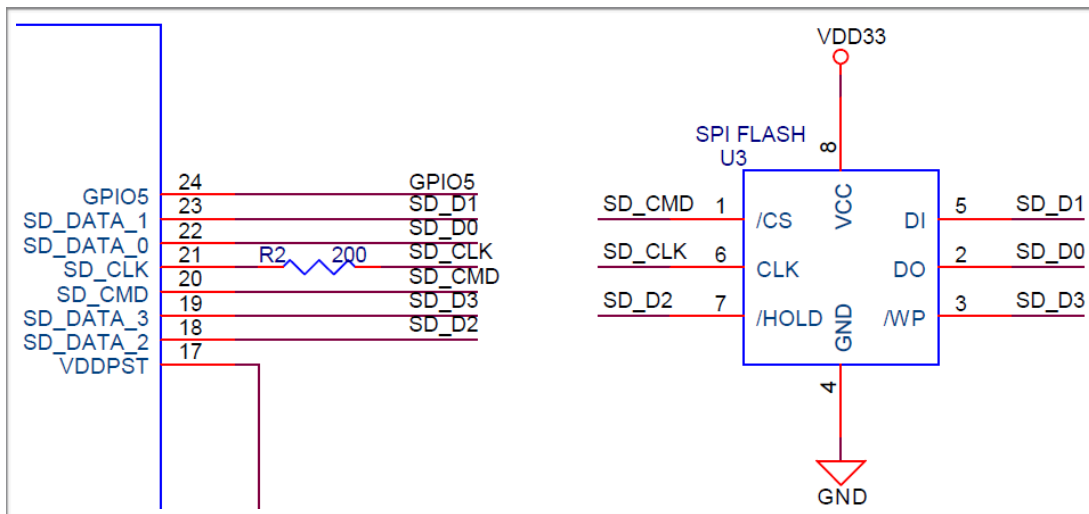

Figure 6 ESP8266EX Flash

2.2.4. Crystal Oscillator

Currently, the frequency of crystal oscillators supported include 40MHz, 26MHz and 24MHz. The accuracy of crystal oscillators applied should be ±10PPM, and the operating temperature range should be between -20°C and 85°C.



When using the downloading tools, please remember to select the right crystal oscillator type. In circuit design, capacitors C1 and C2, which are connected to the earth, are added to the input and output terminals of the crystal oscillator respectively. The values of the two capacitors can be flexible, ranging from 6pF to 22pF, however, the specific capacitive values of C1 and C2 depend on further testing and adjustment on the overall performance of the whole circuit. Normally, the capacitive values of C1 and C2 are within 10pF if the crystal oscillator frequency is 26MHz, while the values of C1 and C2 are $10\text{pF} < C1, C2 < 22\text{pF}$ if the crystal oscillator frequency is 40MHz.

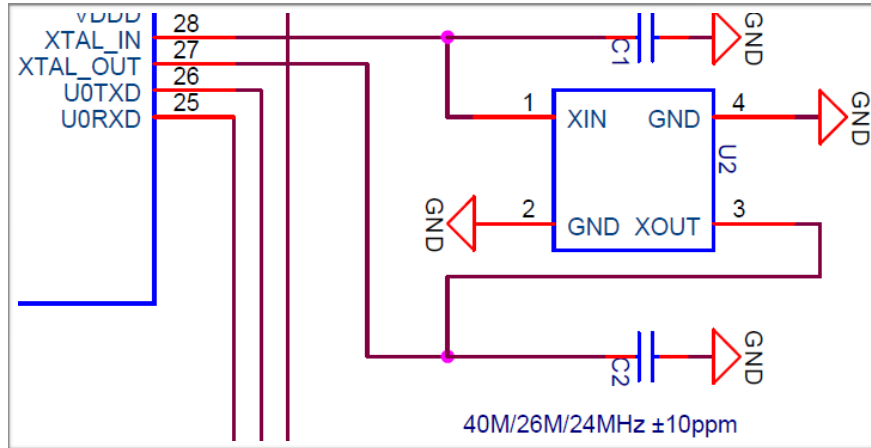

Figure 7 ESP8266EX Crystal oscillators

Note: Defects in the craftsmanship of the crystal oscillators (for example, high frequency deviation, unstable working temperature) may lead to the malfunction of ESP8266EX, resulting in the decrease of overall performance.

2.2.5. RF

The output impedance of RF pin (Pin 2) is 50 ohm. Normally, when the antenna impedance approaches 50 ohm, antenna matching is not necessary. However, low-price antenna commercially available in the market does not feature 50 ohm impedance. Besides, the impedance in 2.4G to 2.5G frequency band is rather scattered. Therefore, N-type matching network is essential in circuit design to facilitate antenna matching.

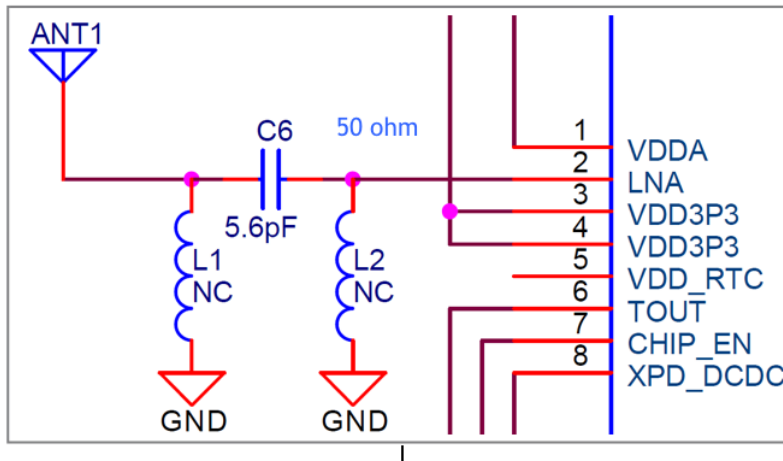

Figure 8 ESP8266EX RF

2.2.6. External Resistor 12K

An external resistor that is connected to the ground should be added to ERS12K pin (Pin31), so as to control the bias current in the circuit. Therefore, relatively high resistance value accuracy is required, an accuracy of $12K \pm 1\%$ is recommended.

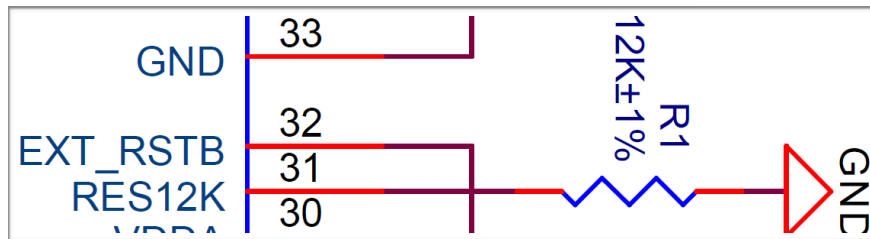

Figure 9 External Resistor

2.3. Layout Design

PCB layout design of products using chipset ESP8266EX is demonstrated in this part. Hereto we mainly focus on two kinds of designs, one is ESP-WROOM serial to WiFi modules, and the other is main board mounted with ESP8266EX WiFi module.

2.3.1. ESP-WROOM Module Design

- **Module layout design and the key techniques:**

This printed circuit board has four layers.

The first layer is the TOP layer, signal lines and components are placed on the top of the printed circuit board;

The second layer is the GND layer, no signal lines is laid so as to ensure an entire plain GND plane;

The third layer is the POWER layer, only power lines can be placed on this layer. However, there is exceptional cases. When there is no other choice but to place some signal lines on this layer, it is acceptable.

The forth layer is the BOTTOM layer, only signal lines are designed on this layer, no components shall be placed on this layer.

- **On design of the power-supply part**

The power supply voltage of those signal lines highlighted in yellow is 3.3V. The total width of the power line shall be larger than 15 mil.

Before the power line reaches the analog power-supply pins (including Pin 1, 3, 4, 28, 29) of ESP8266EX, a 10uF capacitor with 0603 or 0805 package needs to be added, as is illustrated in Fig. 10. C6, which is the capacitor, should be placed adjacent to the analog power-supply pins of the chipset.

Power lines should be placed on the third layer. When the power lines reached the pins of the chipset, VIAs are needed so that the power lines can go through the layers to connect the pins of the chipset on the TOP layer. The diameter of the VIA holes should exceed the width of power lines, while the drill should be appropriate, a little bit larger than the radius of VIA is enough.

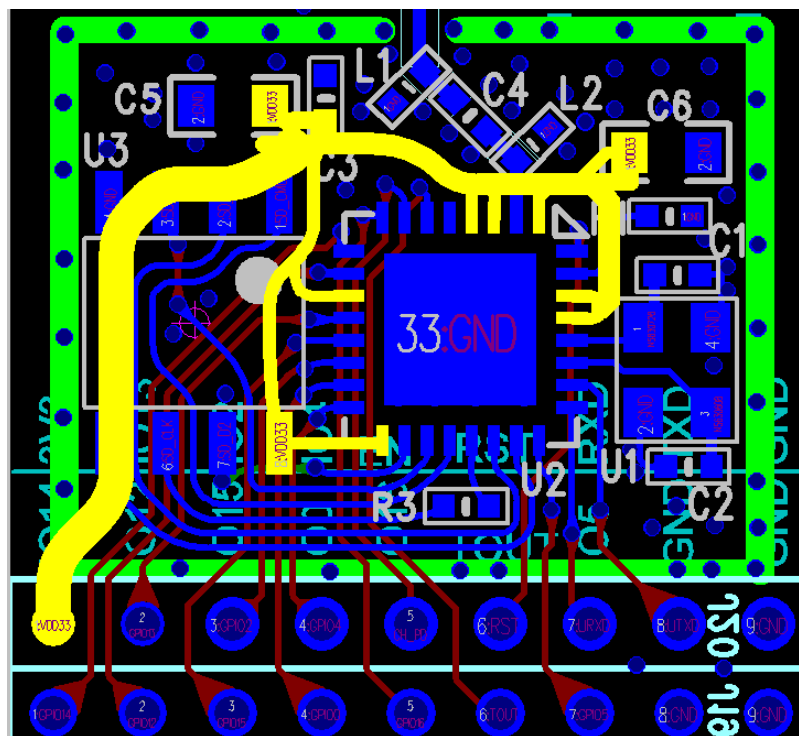



Figure 10 ESP8266EX PCB Layout

- **On design of the crystal oscillator**

Crystal oscillator should be placed adjacent to the XTAL Pins, the connection lines shouldn't be too long, and should be wrapped up for shelter.

The input and output lines cannot be punched, cannot cross the layers or be crossed.

The input and output bypass capacitor should be located near the chip; never set it on the lines.

No high frequency digital signal lines shall be placed under the four layers of the crystal oscillators. The best choice is that no signal lines is placed under the crystal oscillator. The TOP layer where is crystal oscillator is placed should be as large as possible.

Magnetic components, such as high current inductors, should not be placed near to crystal oscillator, a sensitive component.

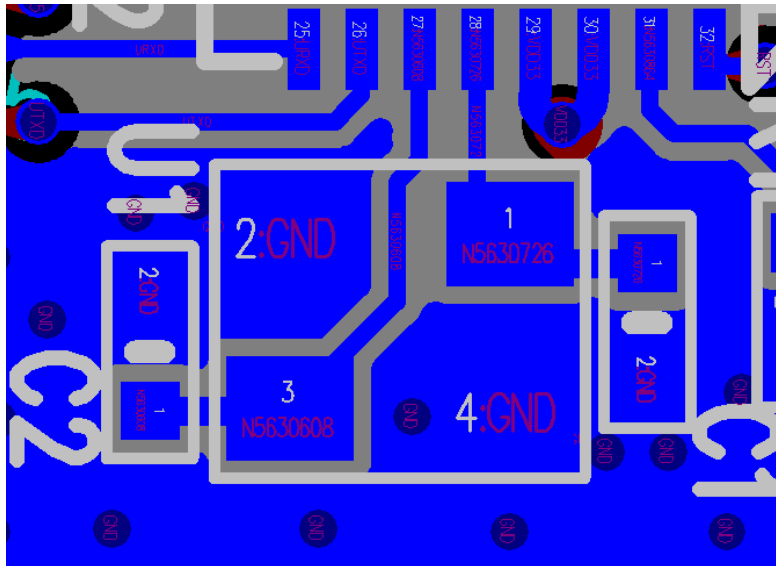

Figure 11 ESP8266EX Crystal Oscillators PCB Layout

- **On design of the RF part**

The characteristic impedance that RF lines should control is 50Ω , in order to ensure the complete board in the second layer. The surrounding drilled hole should be blocked and the lines should be as short as possible.

An matching circuit near the RF Pin should be reserved in RF lines. RF lines connecting the chip and antenna should not cover drills, which means cross layer lines are not allowed.

The width of RF lines should not be less than 6 mil and should keep up to 10 mil.

RF lines should not be set at a vertical, or a 45-degree angle. Circular lines are allowed if necessary.

No signal lines of high frequency should be set near RF lines.

RF antenna should be set away from high frequency transmitting devices, such as crystal oscillators, DDR, and certain high frequency clocks (SDIO_CLK, etc).

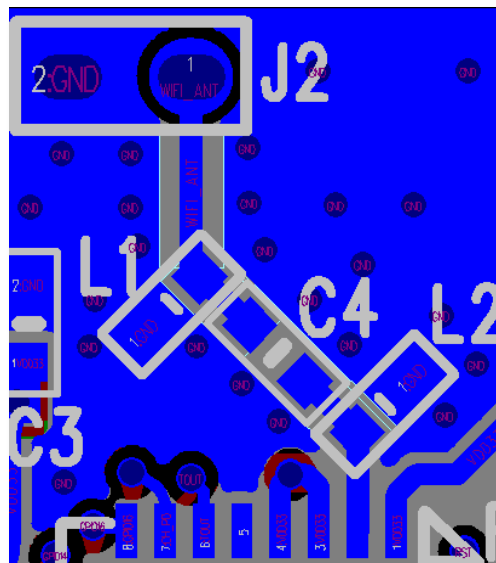

Figure 12 ESP8266EX RF PCB Layout

2.3.2. ESP8266EX as Slave Device

When ESP8266EX is matched with CPU as a slave unit, information integrity in layout design is more important than that in analogue design.

Due to the system accountability, the increasing high frequency signals would result in interference in ESP8266EX. Attentions should be paid to those interferences.

Main boards in PAD or TV BOX will be discussed.

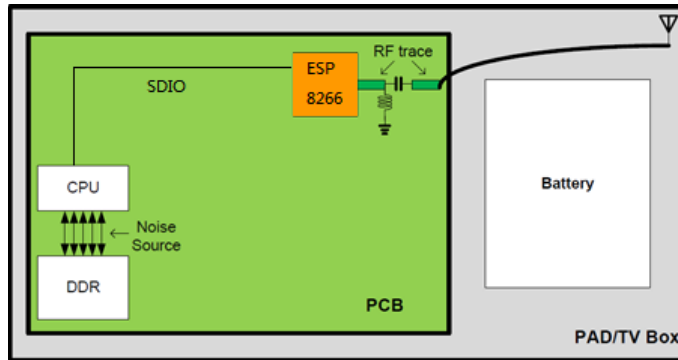

Figure 13 Planning Framework of Layout Plane Position

The digital signals between CPU and DDR produces high frequency noise and will interference WiFi frequency in the air. Therefore, the following points should be noted in system designs:

- As shown in Fig.4, ESP8266EX is on the edge of PCB and far away from CPU and DDR(the noise source CPU+DDR). The increase in distance will decrease the interference distance and would reduce the coupling noise;
- When ESP8266EX communicates with CPU via SDIO, it would be optimal if the six signal lines are connected through a 200Ω series resistor. The purpose is to reduce the drive current and the corresponding interference and at the same time sequence problems due to the inconsistent length of SDIO lines.
- PCB onboard antenna should not be selected as it receive relatively large interferences and is vulnerable to the coupling noise that might affect RF performance. External antenna should be applied that can be directed away from the PCB board so that the influence of interference signals of high frequency on WiFi will be reduced.
- During layout, the high frequency signal line control between CPU and MEM should be noted. The line layout should comply firmly with high frequency signal regulations (refer to DDR line control documents) where CLK should be lined underground, data lines and addr lines should be packed and lined underground.
- The GND of WiFi circuit and other high power devices should be separated and connected through wires if there are electric machines in system design.
- Antenna should keep away from noise source of high frequency, such as LCD, HDMI, Camera Sensor, USB and other high frequency signals.



2.3.3. FAQ On Hardware Design

1. Typical phenomenon: The current ripple is not large, but the TX performance of RF is rather bad.

Problem description: ripple has a strong impact on the performance of RF TX. It should be noted that ripple must be tested when ESP8266EX sends normal packets. The ripple increases when the power gets high. Generally, the ripple value should $<120\text{mV}$ when sending the packet 11N MCS7 the ripple value should $<200\text{mV}$ when sending the packet 11B 11M.

Solution: add a $10\mu\text{F}$ filter capacitor to the branch of source circuit (ESP8266EX AVDD pin). $10\mu\text{F}$ capacitor should be placed adjacent to the VDDA pin. The ripple is much small and more stable when it's near the pin.

2. Typical phenomenon: when the chipset is sending data packages, the power ripple is small and the TX performance of the RF is not good

Problem description: the poor TX performance of the RF is not only caused by the problematic power ripple, but also by abnormal crystal, for example, the crystal itself is of low quality and the crystal frequency offset is too big (when over $\pm 40\text{PPM}$, the ESP8266EX will not be able to work properly and the performance will get worse accordingly); or the crystal has been interfered with high frequency signals, for example, the input signals couple with the output signals or the output signals couple with the input signals due to the cross wiring of input and output signal wires at different layers; or high frequency signal wires are wired below the crystal such as the SDIO wiring and UART wiring, which will cause malfunction of the crystal. Another problem that has not received due attention is the existence of inductive or radioactive parts beside the crystal, for example, great inductance, antenna (many designers, when considering the area of the ESP8266EX module, often place the crystal very close to the PCB on-board antenna, which, at the time ESP8266EX module sends data packages, will lead to direct coupling between radioactive interference and the crystal, the crystal and the antenna, thus resulting in very poor performance of the RF).

Solution: this problem is mainly caused by inconsiderate layout and can only be solved by re-layout. See Chapter 2.7.2 for details about layout.

3. Typical phenomenon: when ESP8266EX is sending data packages, the power value tested by an instrument is much higher or lower than the target power value, and the EVM is relatively poor

Problem description: the sharp difference between the power value tested by an instrument and the target power value is largely caused by the mismatch of the resistance in the section from the chipset RF pin to the antenna. That is to say the resistance in the section from the chipset RF pin to the antenna deviates from the 50Ω a lot, leading to reflections during signal transmission. The reflections



can be divided into positive reflection and negative reflection. When the resistance in the section from the chipset RF pin to the antenna is larger than 50Ω , positive reflection will be formed and the power will grow bigger than normal; if the resistance is smaller than 50Ω , negative reflection will be formed and the power will become smaller than normal. By the way, mismatch of the resistance will affect the performance of the PA within the chipset, leading to PA's premature entry into the saturation regions, thus resulting in large distortion of the signals and according poor EVM performance.

Solution: leave a π shaped circuit on the RF wiring, which shall allow match of the resistance with the antenna, so as to enable the resistance in the section from the chipset RF pin to the antenna to approximate 50Ω .

4. **Typical phenomenon: TX performance is not bad, but the RX sensitivity is rather high.**

Problem description: Good TX performance means proper RF impedance matching. RX performance is strongly influenced by the external interference coupling to the antenna. As modules pose no other high frequency signal coupling to the antenna, RX sensitivity is thus not influenced except when crystal oscillators are set near the antenna, or UART TX and RX conducts through RF trace lines. If ESP8266EX serves as slave, there will be quite a number of high frequency interference. Therefore, signal interference depends on board design.

Solution: keep the antenna away from crystal oscillators and keep RF trace lines away from high frequency signal.



3. ESP-LAUNCHER Development Board

Espressif Systems provides ESP8266EX development board for quick evaluation and familiarisation of products and for secondary development for customers. The size of the demo board is 46mm*78.5mm. Functional components on the demo board are illustrated in the Figure 14 below.

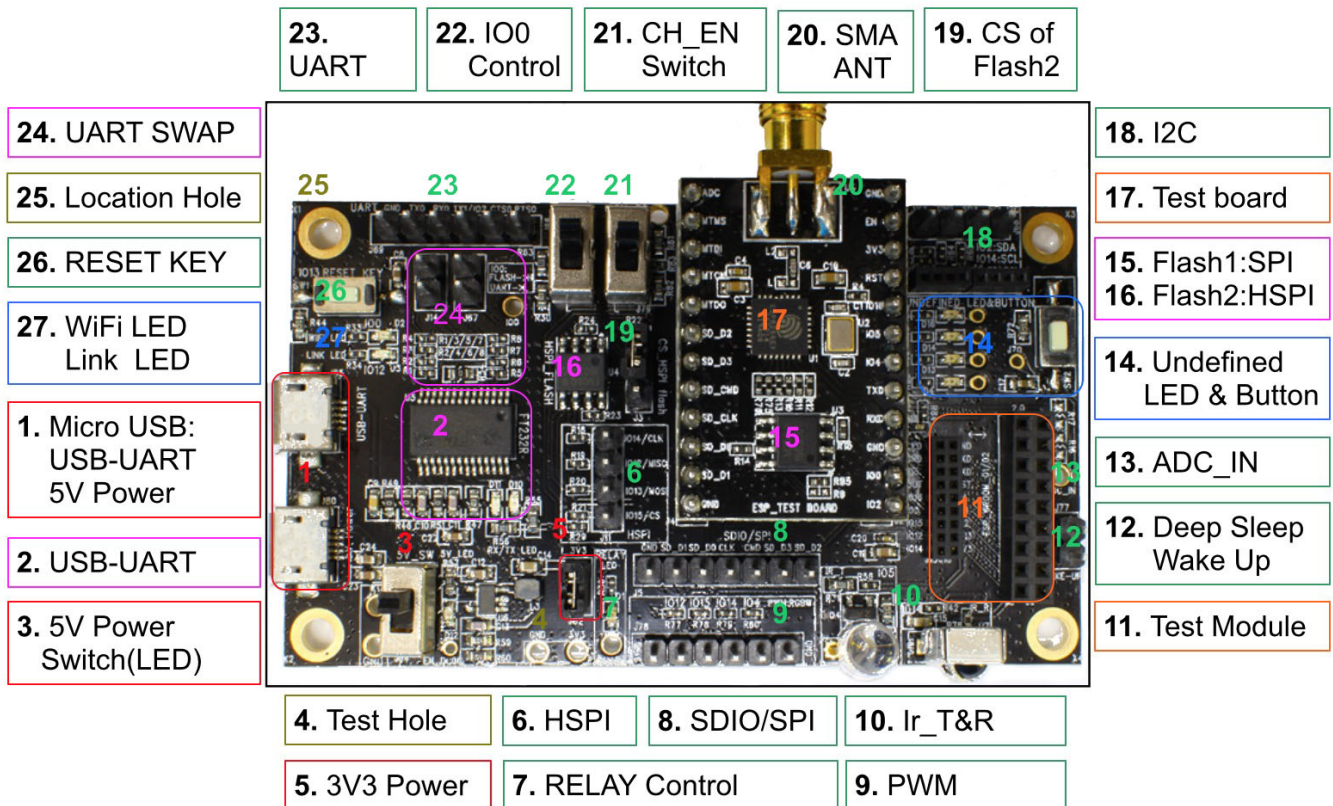

Figure 14 ESP8266EX Development Board



3.1. Instructions on the Use of ESP-LAUNCHER Development Board

Users can connect the development board to a PC using USB interface or WiFi wireless connection interface, then configure and test the demo board. Functional descriptions of components on the development board is illustrated in Table 3 below.

Notice  :

For development board provided **BEFORE** July 1, 2015, both of the two Micro USB interfaces should be powered on. Among them, one is used for 5V power supply, the other one used for serial communication.

For development board provided **AFTER** July 1, 2015, the two Micro USB interfaces can both be used for 5V power supply and serial communication. You can choose any one of them.



Name	Functional Description
Micro USB Interface	There are two USB interfaces, one is used for 5V power supply, the other one is used for serial communication. (Refer to Part 1 in Fig. 14) Please pay attention to the notice on Page 25.
Power Supply	One USB interface is used to supply 5V power, while a DC/DC regulator is used convert 5V to 3.3V, supplying power for WiFi part. There is one indicator light besides the 3.3V power, and a skip stitch that can be used to test the power current.
Slide Switches	Slide switches are used to convert voltage level of GPIO0 interface and chip enable pin CH_EN. It should be noted that when a slide switch is pulled up, the voltage level is high, while when pulled down, the voltage level is low. (Refer to Part 3, 21, and 22 in Fig. 14)
Reset Buttons	SW1 is connected to MTCK (GPIO13), and is used for resetting IoT applications. Function of SW2 has not defined yet. (Refer to Part 26 and 14 in Fig. 14)
Indicator lights	Red light (D2) is an indicator light for the working condition of WiFi. It's not available now!
	Blue light (D3) is an indicator light for the communication of the server. (Refer to Part 27 in Fig. 14)
	Green light (D1) is an indicator light for relay switch control. (Refer to Part 7 in Fig. 14)
	Blue light (D11) and Red light (D10) indicate working status of Rx and Tx serial ports respectively. (Refer to Part 2 in Fig. 14)
	Red light (D12) is indicator light for 5V power supply. (Refer to Part 3 in Fig. 14)
	Function of D4, D13, D14, and D16 can be defined by users themselves. (Refer to Part 14 in Fig. 14)
Jumpers	J82: It needs to be short-circuited using a jumper, so that 3.3V power supply can be connected to other posterior circuits. It can also be used to test the power of the circuit. (Refer to Part 5 in Fig. 14)
	J3: It functions as chip selection for HSPI flash. HSPI flash is closed when the jumper is short-circuiting connected to the upper two needles, while HSPI is enabled when the jumper is short-circuiting connected to the lower two needles. (Refer to Part 19 in Fig. 14)
	J14 and J67: When J14 is short-circuiting connected, it indicates that GPIO13 is connected to U0CTS; when J67 is short-circuiting connected, it indicates that GPIO15 is connected to U0RTS. (Refer to Part 24 in Fig. 14)
	J77: When J77 is short-circuiting connected, it indicates that GPIO16 is connected to EXT_RSTB. This can be used to awake the device from deep-sleep mode. (Refer to Part 12 in Fig. 14)
Interfaces	UART, HSPI, SDIO/SPI, I2C, ADC_IN, GPIO16, relay control, PWM, IR TX and RX



Flash	<p>Flash1 (the one mounted on the test board): Flash1 is connected to the chipset using SPI interface. Currently, Flash1 is mainly used when the chip is working under WiFi standalone mode. R9 and R85 can be used as chip select of Flash1. By default, Flash 1 is enabled. (Refer to Part 15 in Fig. 14)</p> <p>Flash2 (the one mounted on the baseboard): Flash2 is connected to the chipset using HSPI interface. HSPI is mainly used in SIP mode, in this application, ESP8266EX chipset is used as slave device, and is connected to the host MCU using the SPI interface that is defined in standard SDIO interface. HSPI is connected to Flash2. J3 can be used as chip select of Flash2. (Refer to Part 15 in Fig. 14)</p>
Modules for Testing	<p>There are several modules that can be connected with ESP-LAUNCHER development board for testing and development, including the test board that is mounted on the baseboard, modules with 1.27mm double-row needles, and 2.00mm double-row needles (including ESP-WROOM-01 and ESP-WROOM-02).</p> <p>It should be noted that pins of the modules should be connected with corresponding pins on the baseboard. Besides, only one type of module can be used at one time. (Refer to Part 17 and 11 in Fig. 14)</p>

Table 3 Descriptions on the Pins of the Development Board



3.2. Pin Definitions of ESP-LAUNCHER Development Board

There are altogether 32 pins on the demo board, which are illustrated in Figure 15 below. Definition of each pin can be found in Table 2.

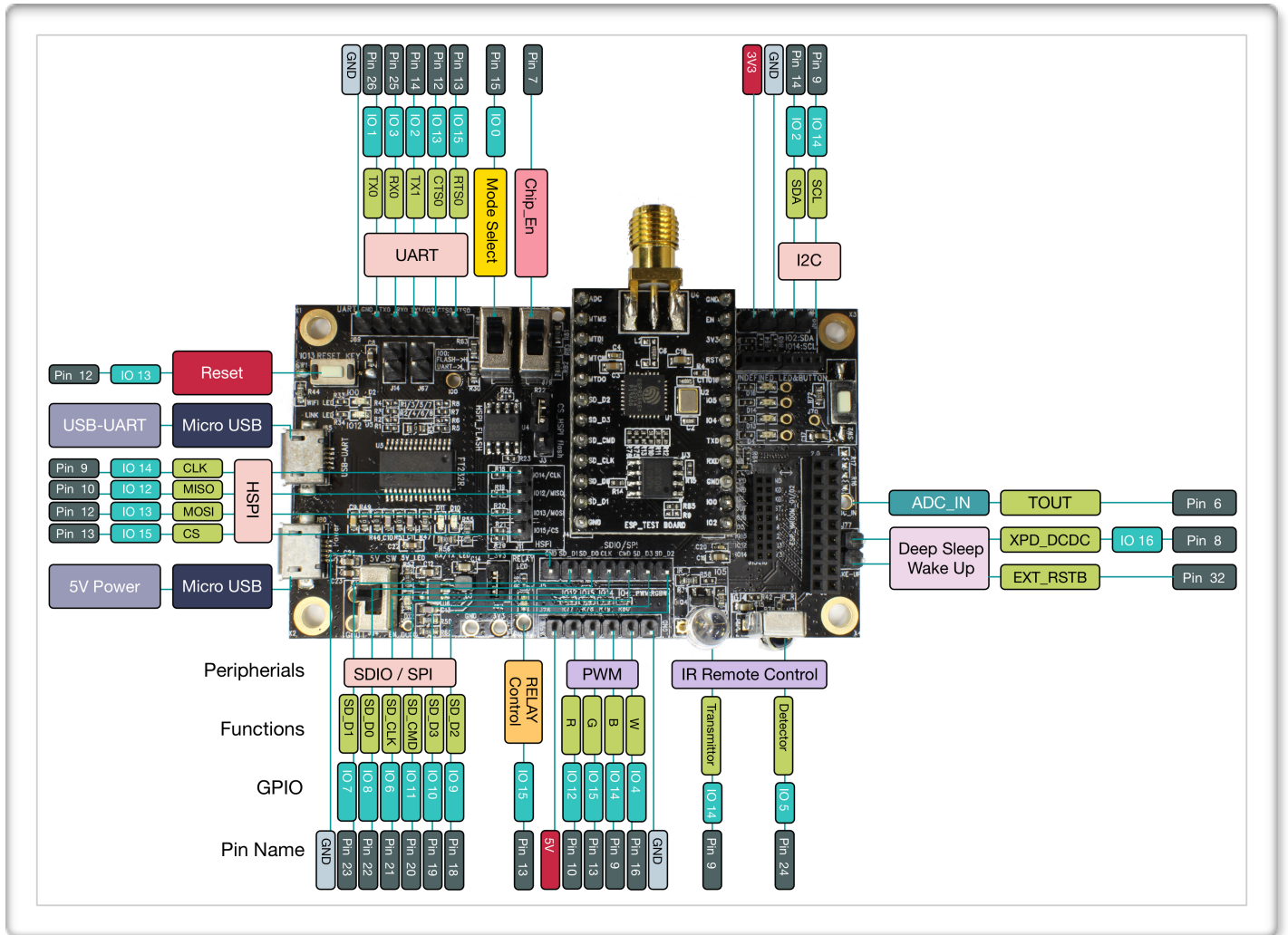

Figure 15 Illustration of Pin Definitions of ESP-LAUNCHER

Table 4 below describes the functions of several interfaces of the development board.



Interface	Functions
HSPI	SPI Flash 2, display screen, and MCU can be connected using HSPI interface.
SDIO/SPI	Flash, host MCU, display screen, etc. can be connected using SDIO/SPI interface.
PWM	Currently the PWM interface has four channels, but users can extend the channels according to their own needs. PWM interface can be used to control LED lights, buzzers, relays, electronic machines, and so on.
IR Remote Control	The functionality of Infrared remote control interface can be implemented via software programming. NEC coding, modulation, and demodulation are used by this interface. The frequency of modulated carrier signal is 38KHz.
ADC	ESP8266EX is embedded with a 10-bit precision SARADC. ADC_IN interface is used to test the power supply voltage of VDD3P3 (Pin 3 and Pin 4), as well as the input voltage of TOUT (Pin 6). It can be used in sensors.
I2C	Sensors and display screens with 2.54mm and 1.27mm needles can be connected using I2C interface.
UART	UART0: U0TXD, U0RXD, MTDO(U0RTS), MTCK(U0CTS) UART1: GPIO2(U1TXD) Devices with UART interfaces can be connected.
	Downloading: U0TXD+U0RXD or GPIO2+U0RXD Communicating: UART0: U0TXD, U0RXD, MTDO(U0RTS), MTCK(U0CTS) Debugging: UART1_TXD (GPIO2) can be used to print debugging information.
	By default, UART0 will output some printed information when the device is powered on and is booting up. If this issue exerts influence on some specific applications, users can exchange the inner pins of UART when initializing, that is to say, exchange U0TXD, U0RXD with U0RTS, U0CTS. R1/3/5/7 should not be mounted with other components, while R2/4/6/8 can be mounted with other components. J14 and J67 should be short-circuiting connected.
Relay Control Terminal	Relay control terminal is used to control the switch on-and-off of smart plugs. There is an indicator light.

Table 4 Functions of Interfaces on ESP-LAUNCHER



Basic steps on how to use the development board:

- Step 1** Connect the development board using two USB data lines, one is used to supply 5V power, one is used to communicate via USB UART interface.
Link for downloading FT232R driver: www.ftdichip.com/Drivers/VCP.htm
- Step 2** Short-circuiting connect J82 (Part 5 in Fig. 14) so as to provide 3.3V power to the WiFi part.
- Step 3** Pull up the switch (Part 21 in Fig. 14) that controls CH_PD (the chip enable pin, valid when the voltage level is high).
- Step 4** If not necessary, short-circuiting connect J3 (the chip selection pin of HSPI flash, Part 19 in Fig. 14) so as to close HSPI flash.
- Step 5** Pull down the switch that controls GPIO0 so as to enter UART download mode.
- Step 6** Connect with the testing board.
- Step 7** Pull up the 5V power supply switch so as the supply 5V power. Red light (D12) is an indicator light for 5V power supply. (Part 3 in Fig. 14).
- Step 8** Open the Flash Download Tool and begin downloading.
Pull down the 5V power supply switch so as to switch off power supply when downloading is completed.
- Step 9** Flash boot: pull up the switch that controls GPIO0 (Part 22 in Fig. 14).
UART debug tool can be used to debug.
- Step 10** Red light (D2) is an indicator light for the working condition of WiFi.
Blue light (D3) is an indicator light for the communication of the server. (Refer to Part 27 in Fig. 14)
- Step 11** Reset button SW1 is used for resetting IoT applications.



3.3. Typical Applications Using ESP-LAUNCHER

3.3.1. ESP-LAUNCHER Test Board

There is one test board on each ESP-LAUNCHER development board, which is shown in Fig. 16 below. The external size of the test board is 20mm*31mm. An 2DBi SMA antenna or other testing equipment can be connected with the test board via the SMA antenna connector. The spacing of inserting needles on the test board is 2.54mm, which can be easily inserted into breadboard for testing.

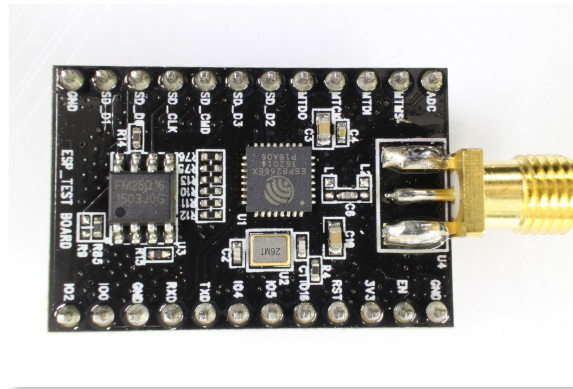

Figure 16 ESP-LAUNCHER Test Board

3.3.2. SMD Module ESP-WROOM-02

The pin definitions and distribution of the SMD Module is illustrated in Figure 17. The external size of the module is 18*20mm. The type of flash used on this module is an SPI flash, the package size of which is SOP8-150mil, the antenna applied on this module is a 3DBi PCB-on-board antenna.

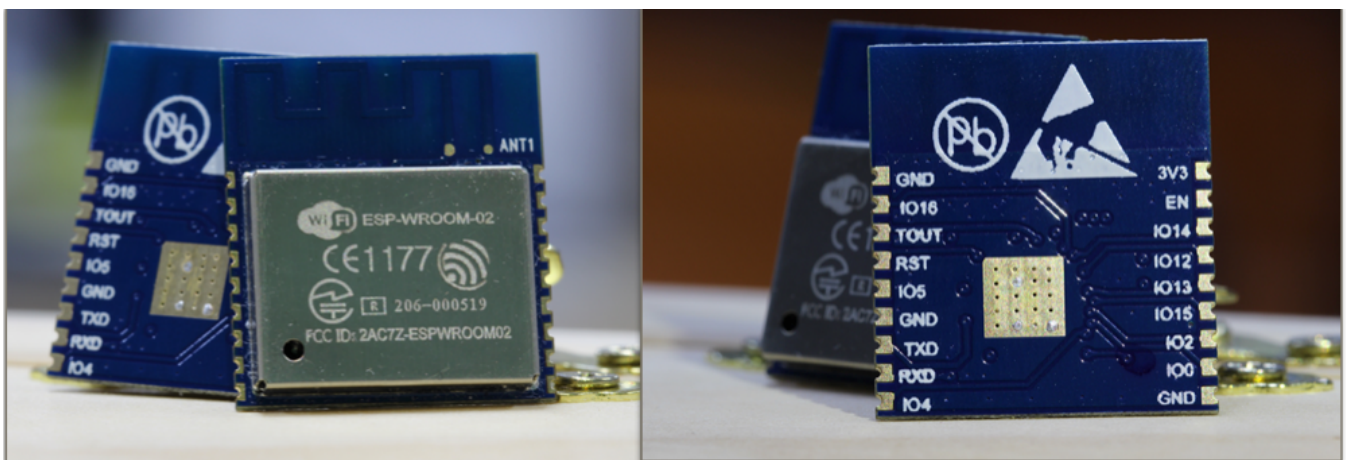

Figure 17 Illustration of SMD Module ESP-WROOM-02

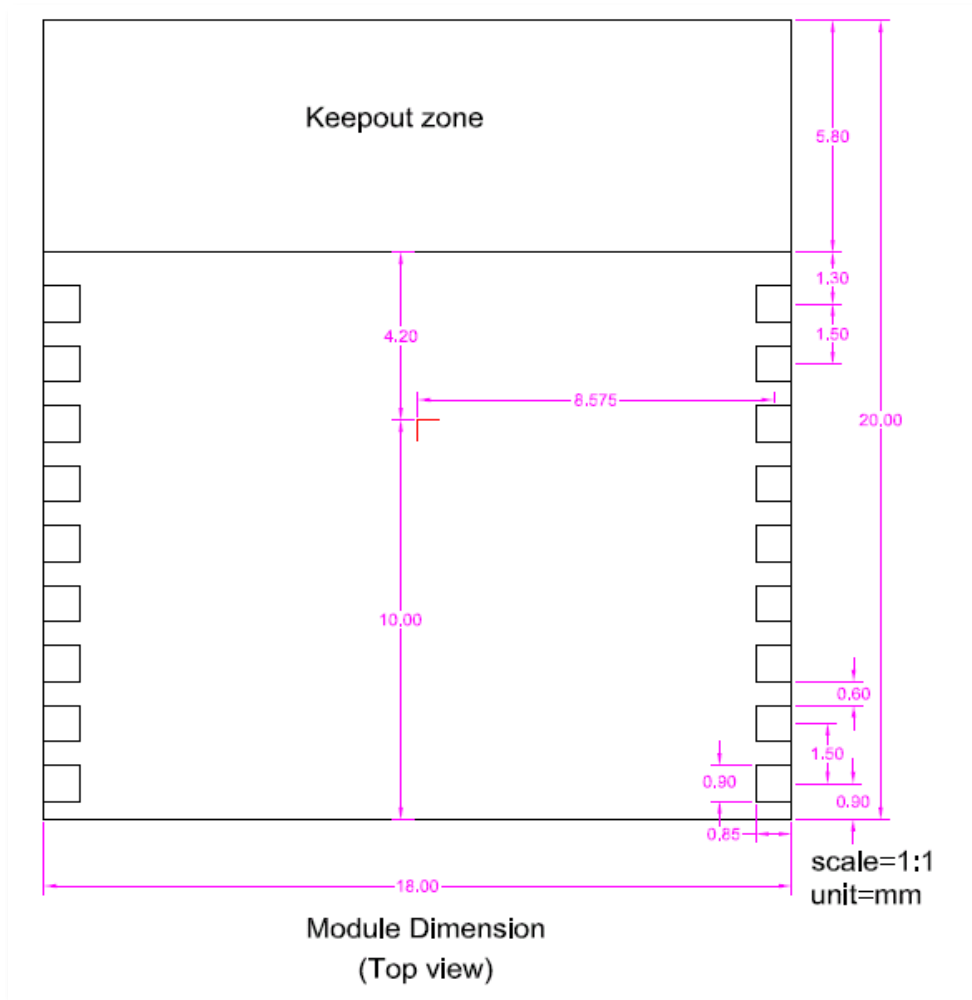

Figure 18 Dimensions of ESP-WROOM-02 WiIF Module

There are altogether 18 pin-outs, the distribution and definitions of which are listed in Table 5 below:



NO.	Pin Name	Function
1	3V3	3.3V power supply (VDD)
2	EN	Chip enable pin. Active high.
3	IO14	GPIO14; HSPI_CLK
4	IO12	GPIO12; HSPI_MISO
5	IO13	GPIO13; HSPI_MOSI; UART0_CTS
6	IO15	GPIO15; MTDO; HSPICS; UART0_RTS
7	IO2	GPIO2; UART1_TXD
8	IO0	GPIO0
9	GND	GND
10	IO4	GPIO4
11	RXD	UART0_RXD; GPIO3
12	TXD	UART0_TXD; GPIO1
13	GND	GND
14	IO5	GPIO5
15	RST	Reset the module
16	TOUT	It can be used to test the power-supply voltage of VDD3P3 (Pin3 and Pin4) and the input power voltage of TOUT (Pin 6). However, these two functions cannot be used simultaneously.
17	IO16	GPIO16; can be used to wake up the chipset from deep sleep mode.
18	GND	GND

Table 5 Pin Definitions of ESP-WROOM-02 WiFi Module

Connect the 3.3V power-supply pin to an external 3.3V power source, for 3.3V is the power-supply for both analog circuit and digital circuit.

When working, normally the voltage level of the EN pin, WiFi enable pin, should be set high.

SMD Module features two working modes: one is UART Download mode, the other is Flash Boot mode. UART Download mode means that user programs can be written into the Flash or Memory by flash downloading tools. If the programs are burnt into the Memory, the programs can run only when the device is powered on, once the device is powered off, the programs in the Memory will be erased. However, when the programs are burnt into the Flash, they will be stored in it, and can be invoked and used at any time.



Before the module is powered on, pin GND RXD TXD should be lead out, and be connected with USB to TTL serial cable (FT232 is suggested) so as to download, print log and communicate.

By default the Flash is empty. Therefore, the following procedures should be followed when you burn the programs into the Flash:

- Before burning, set the module to work under UART Download mode;
- Pull IO15 and IO0 to low-voltage level, leave IO2 dangled;
- Burning the programs into Flash;
- Burning the program into Flash using flash downloading tools;
- After burning the programs into Flash, pull down IO15 to low-voltage level, keep IO2 dangled, and pull up IO0 to high-voltage level. The module is then shifted from UART Download mode to the Flash Boot mode;
- The initialisation would read and run programs from Flash after it is powered on.

Note:

- The whole operating process can be examined through the log information printed by UART interface. If the programs written into the Flash do not function in the right way, please check the initial settings of the working mode through logs printed from a serial port.
- Serial printing tools (for example, SecureCRT) and flash downloading tools cannot open the serial port simultaneously.



3.3.3. DIP Module ESP-WROOM-01

The DPI type module - ESP-WROOM-01 is illustrated in Figure 18 below.



GND	GND
U0TXD	GND
U0RXD	GPIO5
RST	TOUT
CH_PD	GPIO16
GPIO4	GPIO0
GPIO2	GPIO15
GPIO13	GPIO12
VDD33	GPIO14

Figure 18 DIP Module ESP-WROOM-01

The size of the module is 18*19mm, the Flash type applied is a SPI flash packed in SOP8-150mil, the antenna used is a 1 DBi metal antenna. The 2.00mm double pitch applied can be both vertical or straight, depending on specific applications.

Please refer to Table 5 for pin definitions of this module.

It should be noted that the DIP metal antenna is thin and prone to distortion. Change the antenna immediately if the shape and appearance are abnormal.



4. Compiling, Downloading, and Debugging

4.1. Set Up the Compiling Environment

The current compiling environment is set up in Lubuntu System, and is entirely merged into a virtual box. Please refer to the post on Espressif BBS for the downloading of compiling environment: <http://bbs.espressif.com/viewtopic.php?f=5&t=2>

On how to compile and download: <http://bbs.espressif.com/viewtopic.php?f=21&t=165>

Please refer to [ESP8266_GCC_LUBUNTU.docx] on how to set up and configure when the compiling system has been downloaded successfully. A Windows sharing folder should also be set up before we run the virtual box. When the configuration and set up of the sharing folder is ready, open the virtual box, and you can see this page as is shown in Figure 19 below:

- Click "LXTerminal"

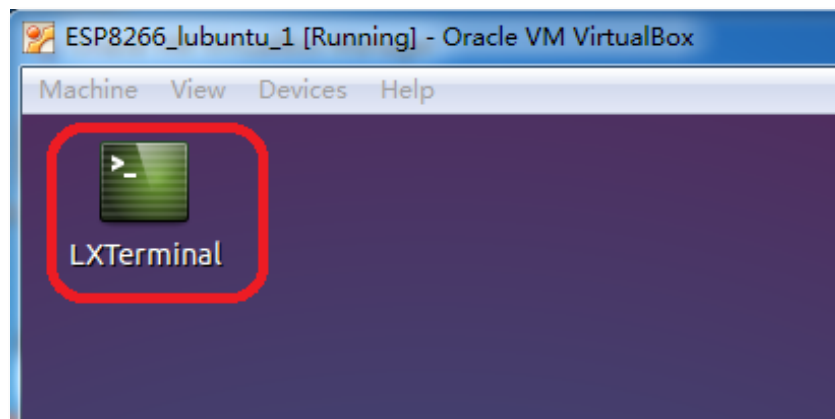

Figure 19 Compiling Tool

- Input `./mount.sh`, and password `espressif`

Please be noted that no hint will pop up when you enter the password, just click Enter Key when you finished the input. Now, the sharing folder in Windows system is uploaded to Lubuntu Systems.

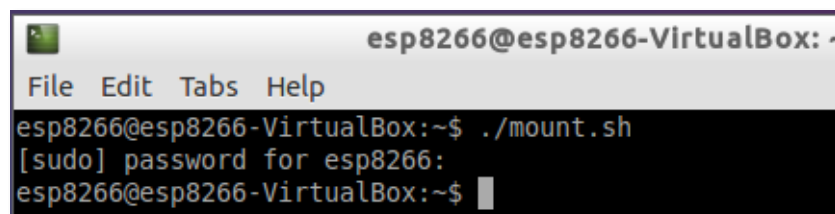
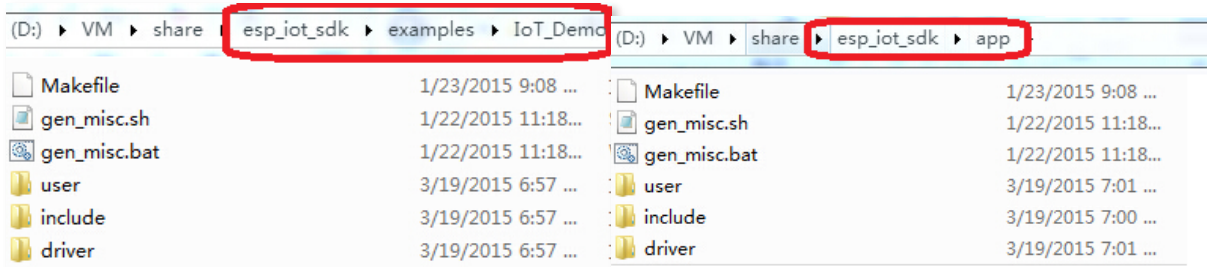

Figure 20 Command

- Copy files in subfolder `esp_iot_sdk\examples` and paste them in folder `esp_iot_sdk\app` for compiling.

Figure 21 Example Codes

- Compiling command: `./gen_misc.sh`. Parameters can be compiled according to specific needs. Please refer to Chapter 2 of documentation *2A-ESP8266_IOT_SDK_User_Manual* on how to compile.

1) `boot_v1.1` and `boot_v1.2+`: `boot_v1.2` is a more compact form of compiling, thus more flash space can be saved. While `boot_v1.3` mainly supports strengthened initiating mode, and is mainly used to do mass production test.

2) Firmware upgrade over the air is not supported: `flash.bin+iromtext.bin`

Firmware upgrade over the air is supported: `boot.bin+user1.bin`

3) It should be noted that `.bin` files with different size must be written to different addresses.

```

esp8266@esp8266-VirtualBox:~/Share/esp_iot_sdk v1.0.1 b2/app$ ./gen_misc.sh
Please follow below steps(1-5) to generate specific bin(s):
STEP 1: choose boot version(0=boot_v1.1, 1=boot_v1.2+, 2=none)
enter (0/1/2, default 2):
1
boot mode: new

STEP 2: choose bin generate(0=eagle.flash.bin+eagle.irom0text.bin, 1=user1.bin,
2=user2.bin)
enter (0/1/2, default 0):
1
generate bin: user1.bin

STEP 3: choose spi speed(0=20MHz, 1=26.7MHz, 2=40MHz, 3=80MHz)
enter (0/1/2/3, default 2):
2
spi speed: 40 MHz

STEP 4: choose spi mode(0=QIO, 1=QOUT, 2=DIO, 3=DOOUT)
enter (0/1/2/3, default 0):
0
spi mode: QIO

STEP 5: choose spi size(0=256KB, 1=512KB, 2=1024KB, 3=2048KB, 4=4096KB)
enter (0/1/2/3/4, default 1):
2
spi size: 1024 KB

start...

```

Figure 22 Options during Compiling

4.2. Download Firmware

When entering the UART download mode, set `MTD0(I015):I00:I02` as `0:0:1`, after downloading successfully, switch to the Flash boot mode `0:1:1`.

Figure 23 below shows how to use Flash Download Tool.

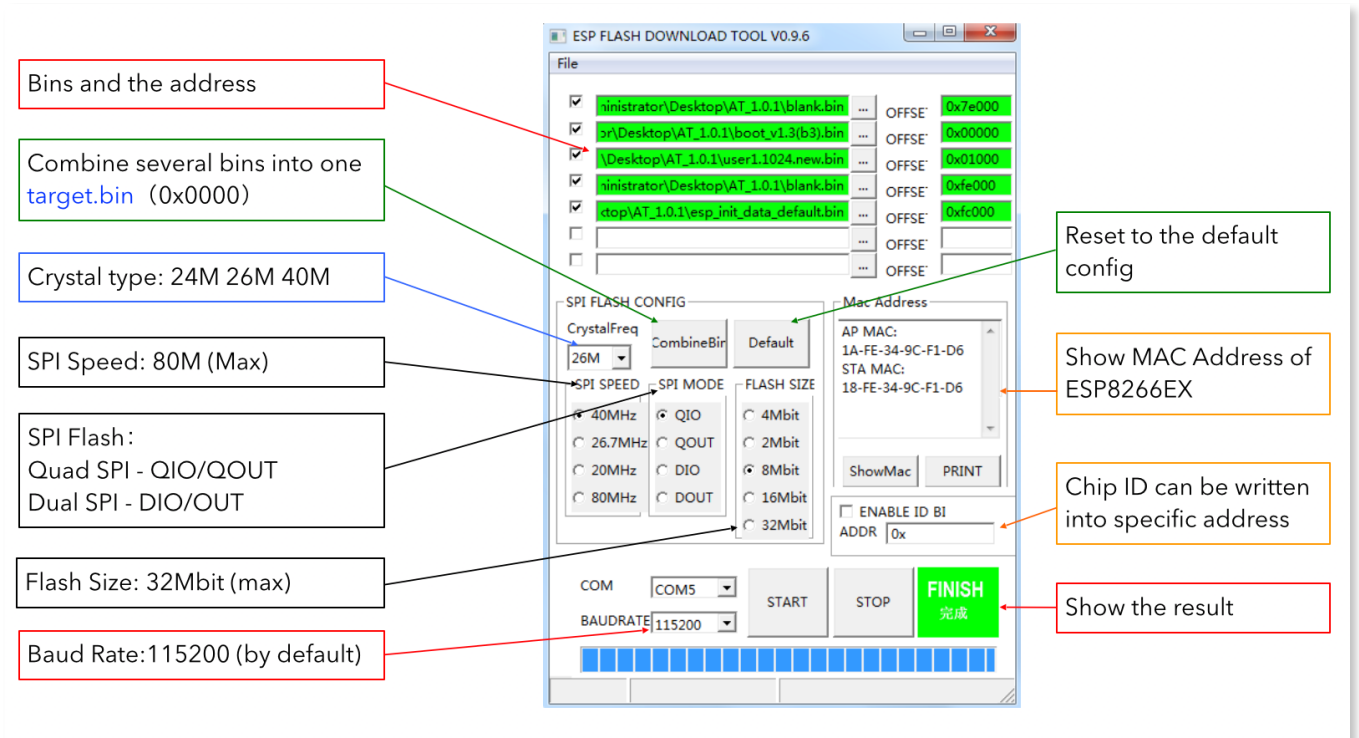
Figure 23 Flash Download Tool

4.3. Debugging AT Commands via UART

1. All AT Commands has to be capitalised, and end with `"/r/n"`. Configure the port and enter the commands.

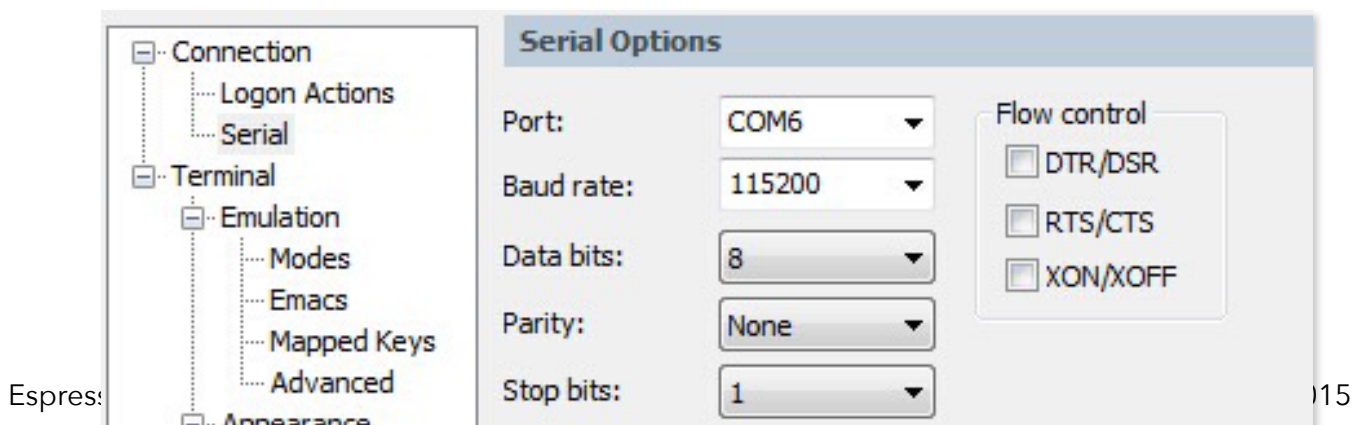

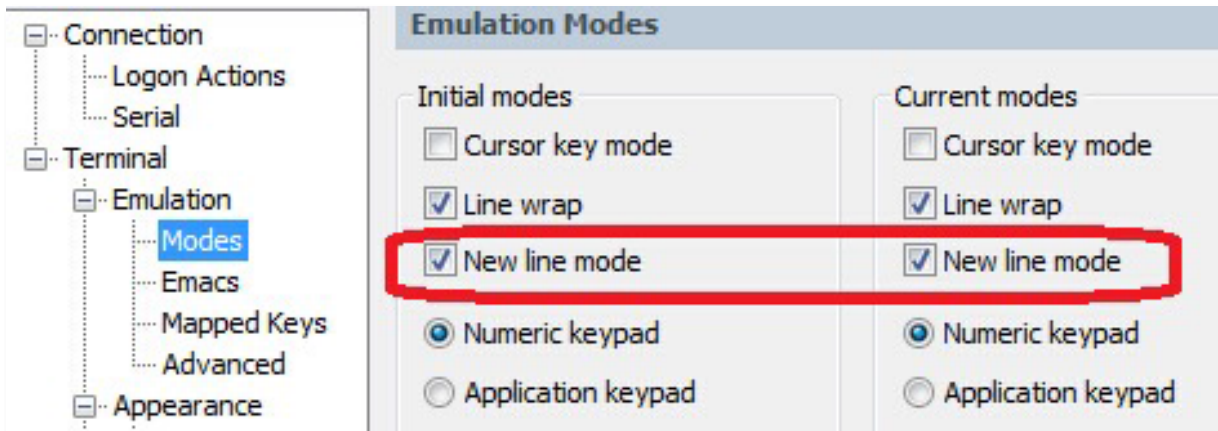

Figure 24 Configuration of UART Serial Port Debugging Tool

2. TCP/UDP debugging via the internet

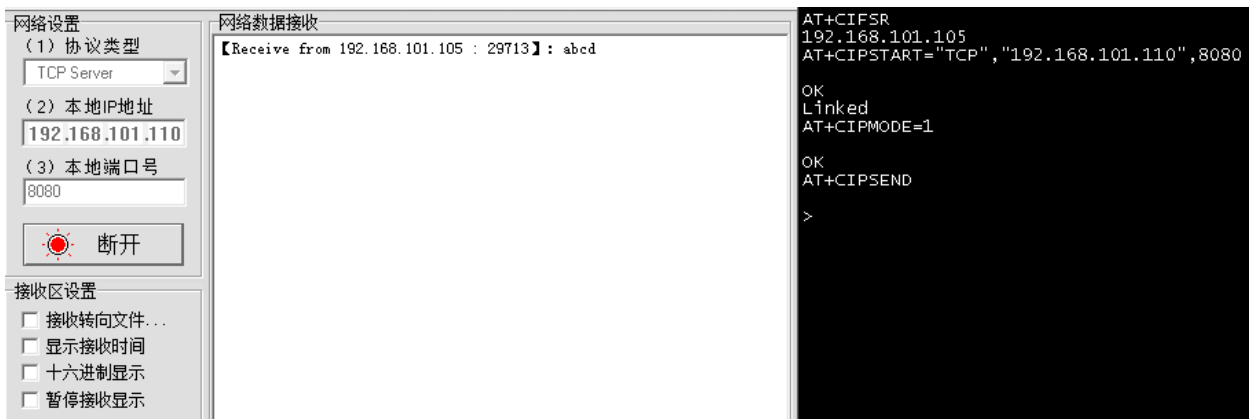

Figure 25 TCP/UDP Debugging



5. Typical Applications

5.1. WiFi smart hardware converted from UART serial ports

The pins on basis of the 2 UART ports are defined below:

Category	Pin Definition	Function
UART0	(Pin 25) U0RXD+ (Pin 26) U0TXD	Can be used to receive and send the users' data packages
UART1	(Pin 14) GPIO2 (U1TXD)	Can be used to print information

Table 19 Pin Definitions of 2 UART Interfaces

AT+ instructions and instruction sets documentations are provided for the relevant software.

Application example: ESP8266EX development board as shown in Figure14.

5.2. Sensor

ESP8266EX can be used to develop sensor products and the interface used is I2C interface. Under this condition, I2C is working with Master mode and is connected to multiple sensors, communicating through addressing mode which identifies Slave device (every slave device has a unique address identity).

Such sensor products will send real-time data through I2C interface to ESP8266EX which will upload the data to the server wirelessly. When an mobile phone is connected to the public internet, it can access the data on the server through an app.

5.3. Smart light

ESP8266EX can be used to develop smart home products such as smart LED lights which use PWM interfaces and infrared interfaces. The 3 PWM interfaces control the red, blue, green LED lights respectively. Theoretically speaking, the minimal PWM duty ratio can reach 1/256, thus supporting 256*256*256 types of colors. Besides, the infrared interfaces allow specific control over LED lights, for example, reset, on/off, adjustment of the colour.



5.4. Smart plug

ESP8266EX can be used to develop smart home products such as smart plugs which use ordinary GPIO interfaces. GPIO interfaces allow control over high and low levels as well as connection and disconnection of relay, thus allowing smart control over plug on/off. This application is mainly comprised of 3 modules which are: 220V to 5V power module, ESP8266EX WiFi module and relay control module.

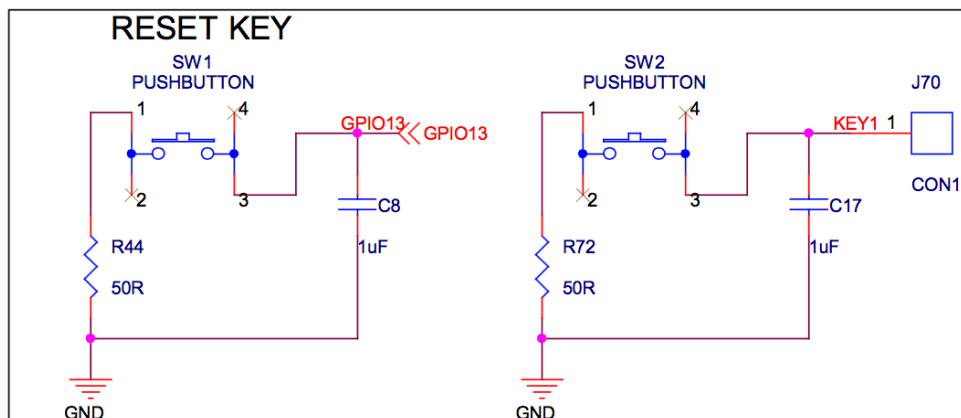
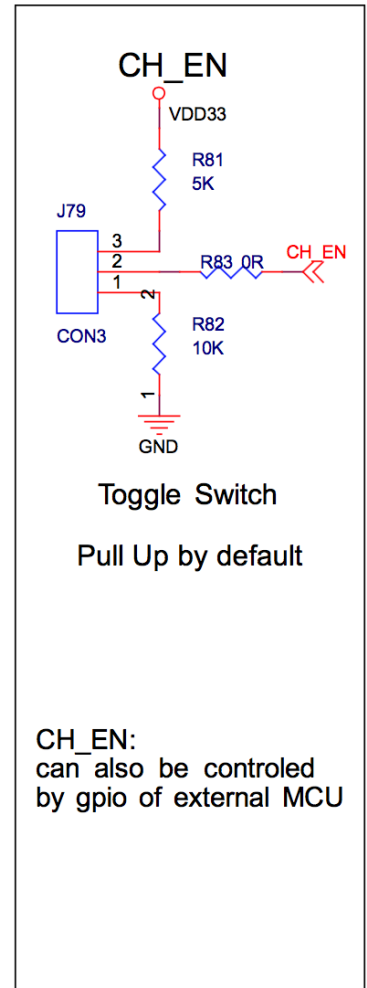
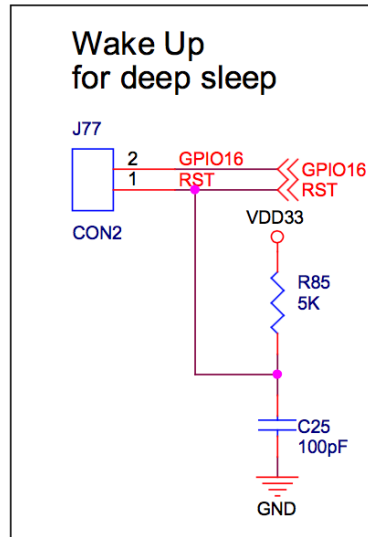
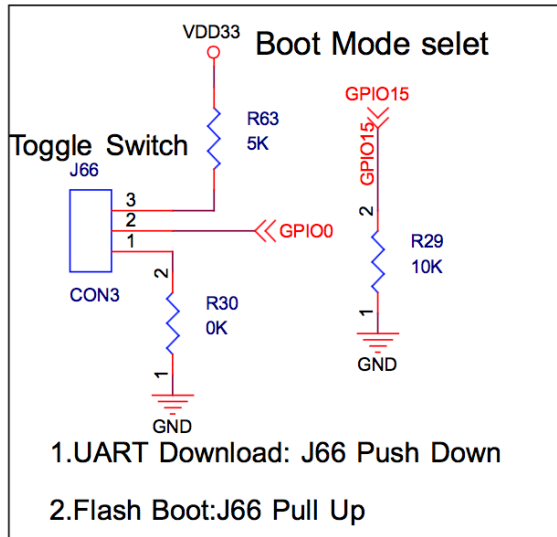

6. Appendix

6.1. Schematics of ESP-LAUNCHER Development Board

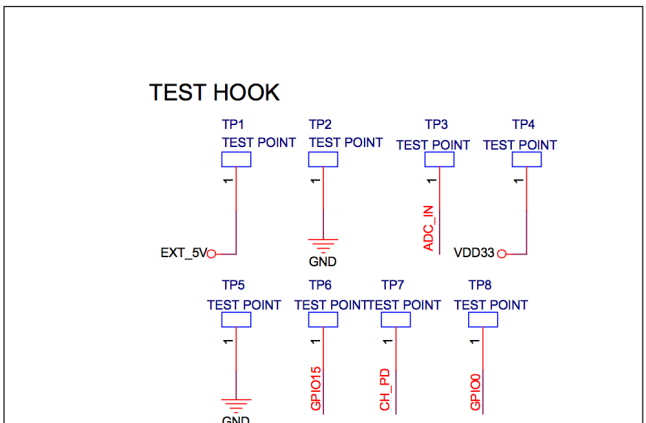
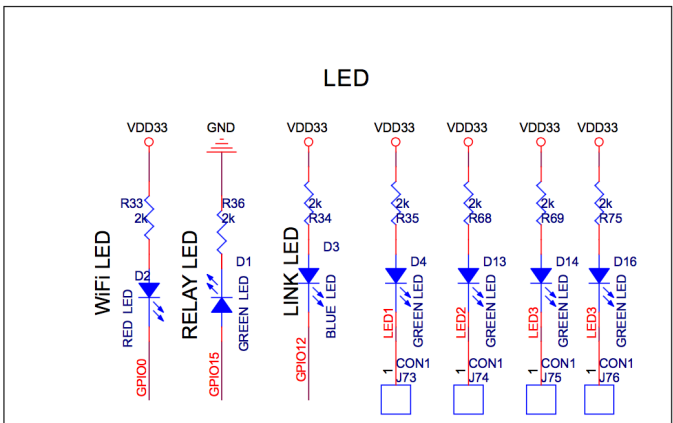
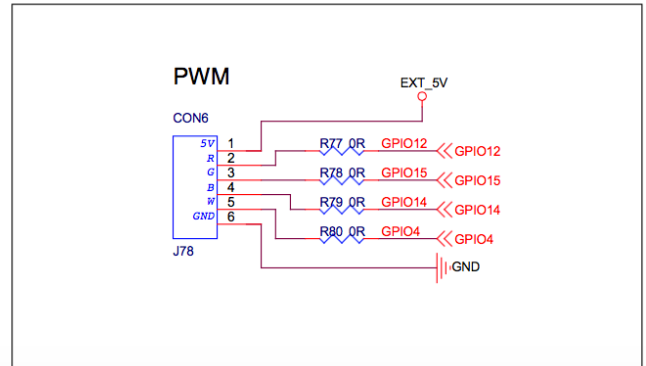
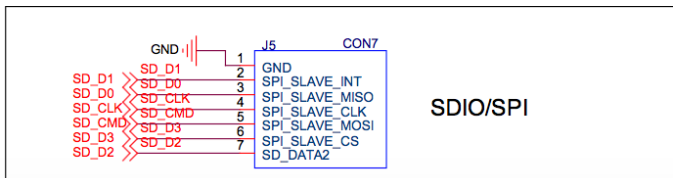
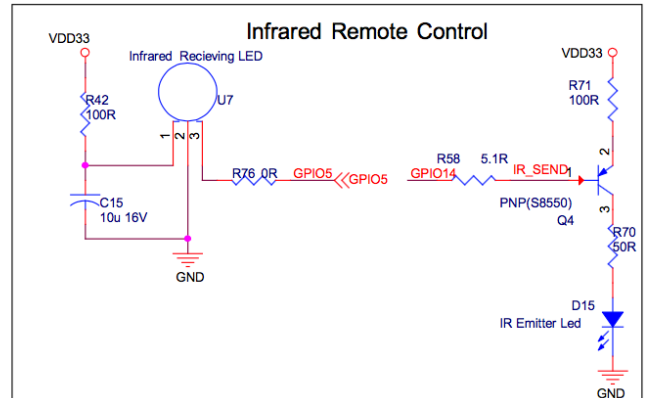
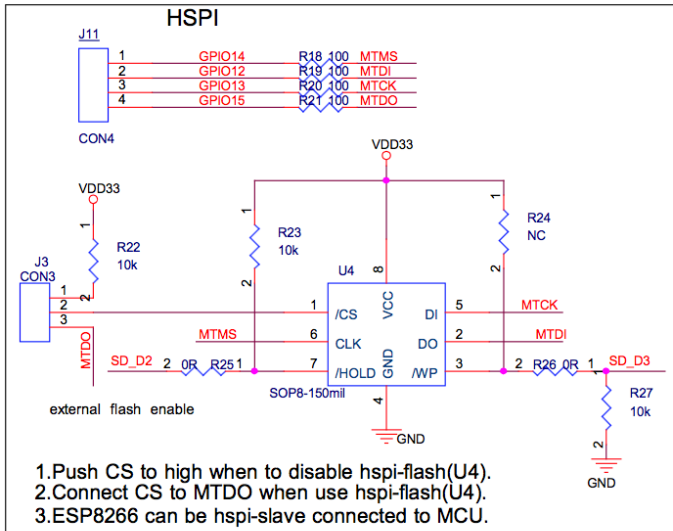
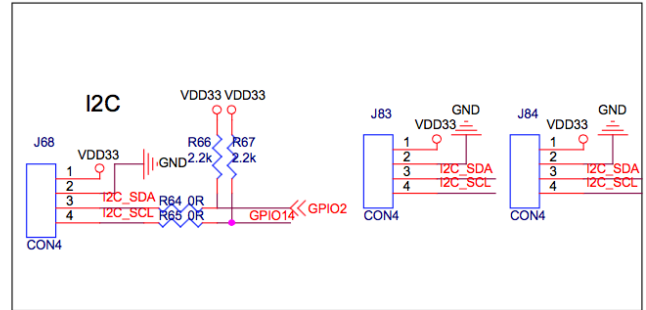
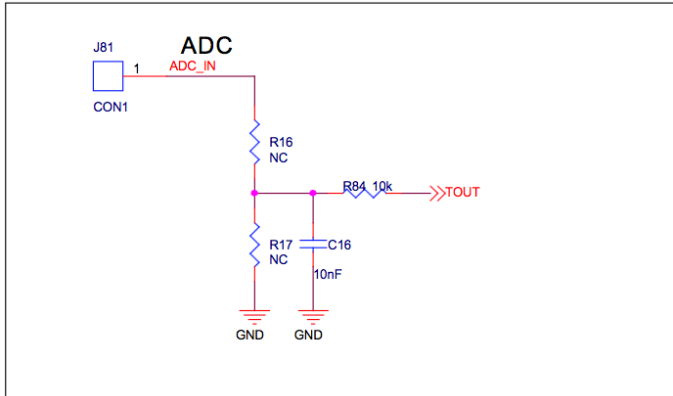



Part 1: Interfaces

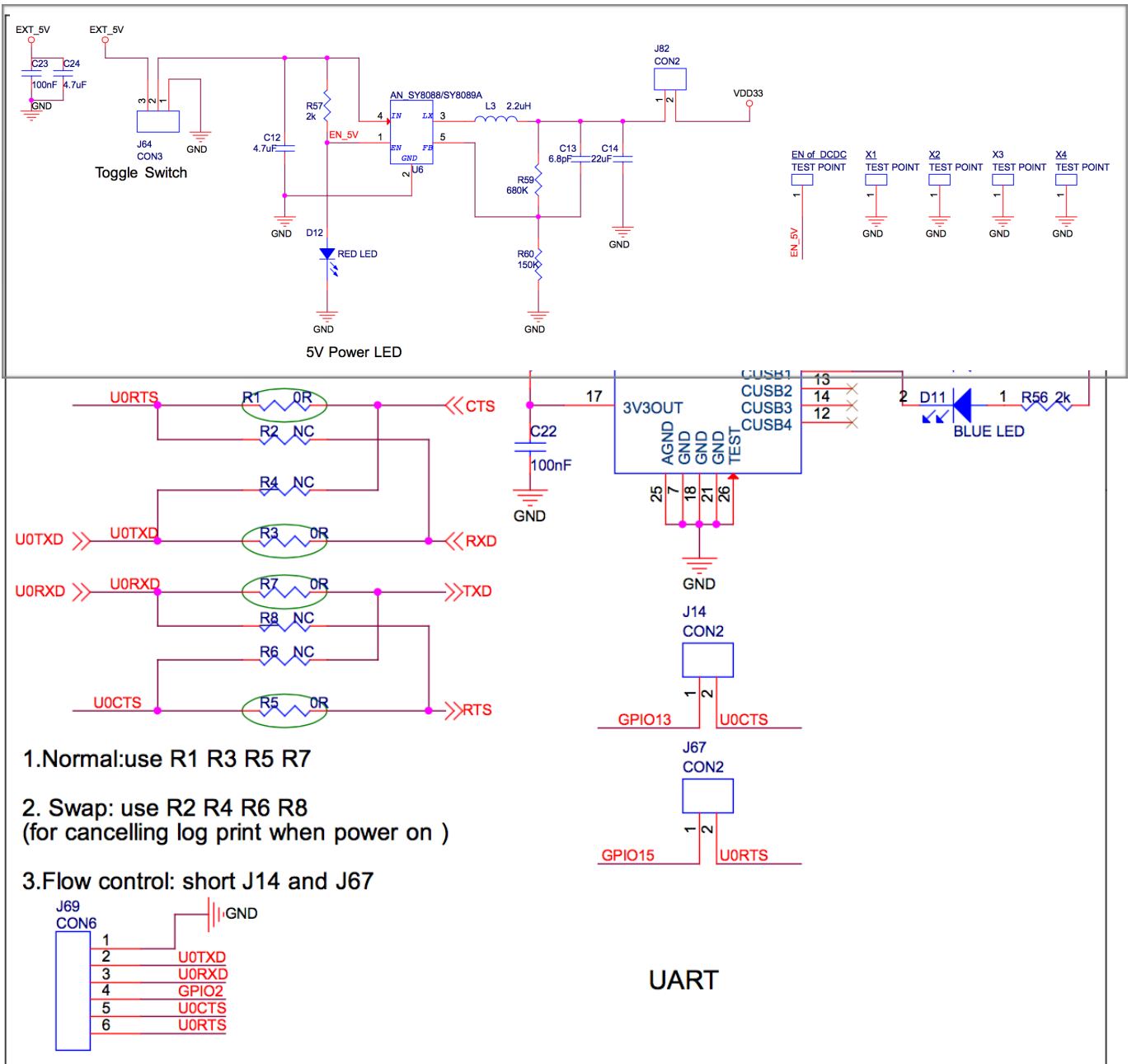

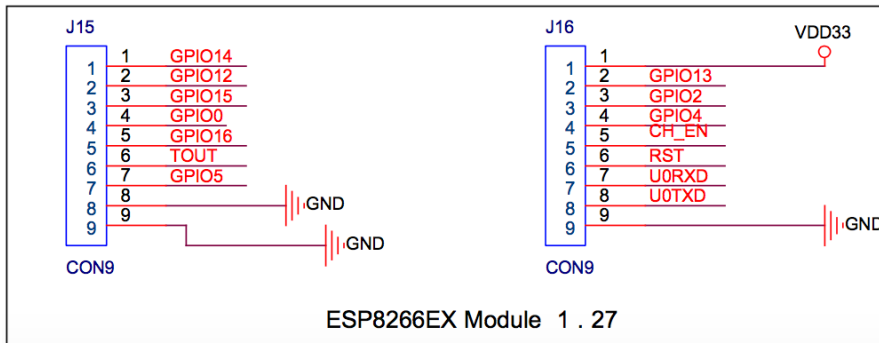
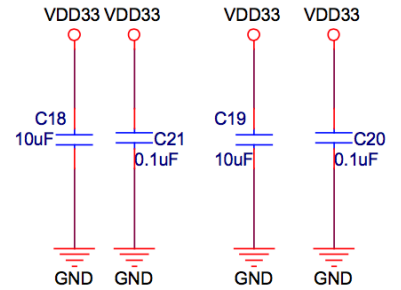
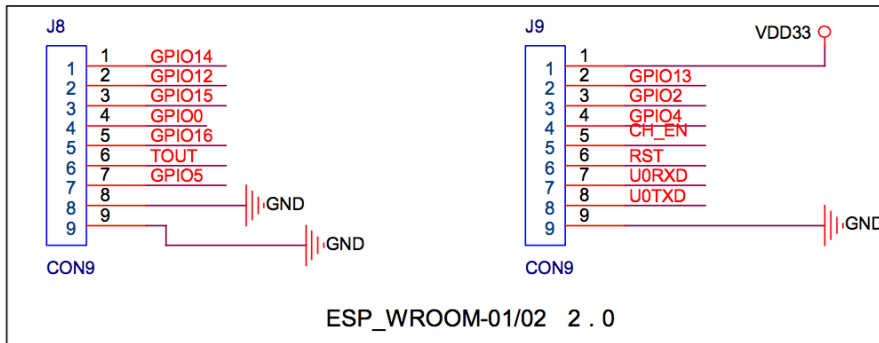
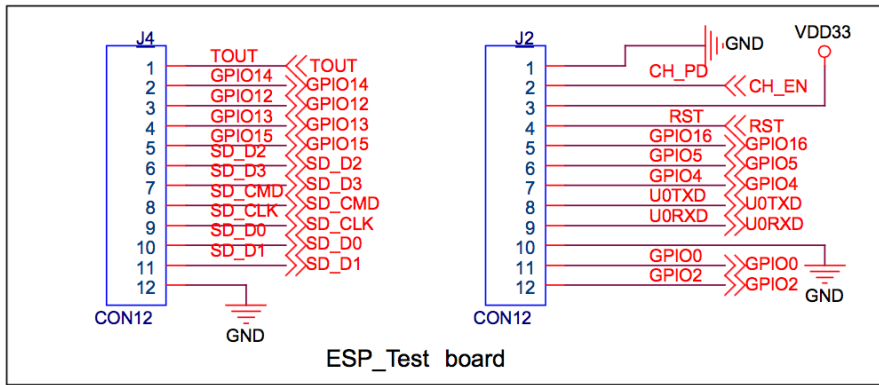



Part 2: 5V Power

Part 3: Test Board

6.2. Schematics of ESP-LAUNCHER Test Board

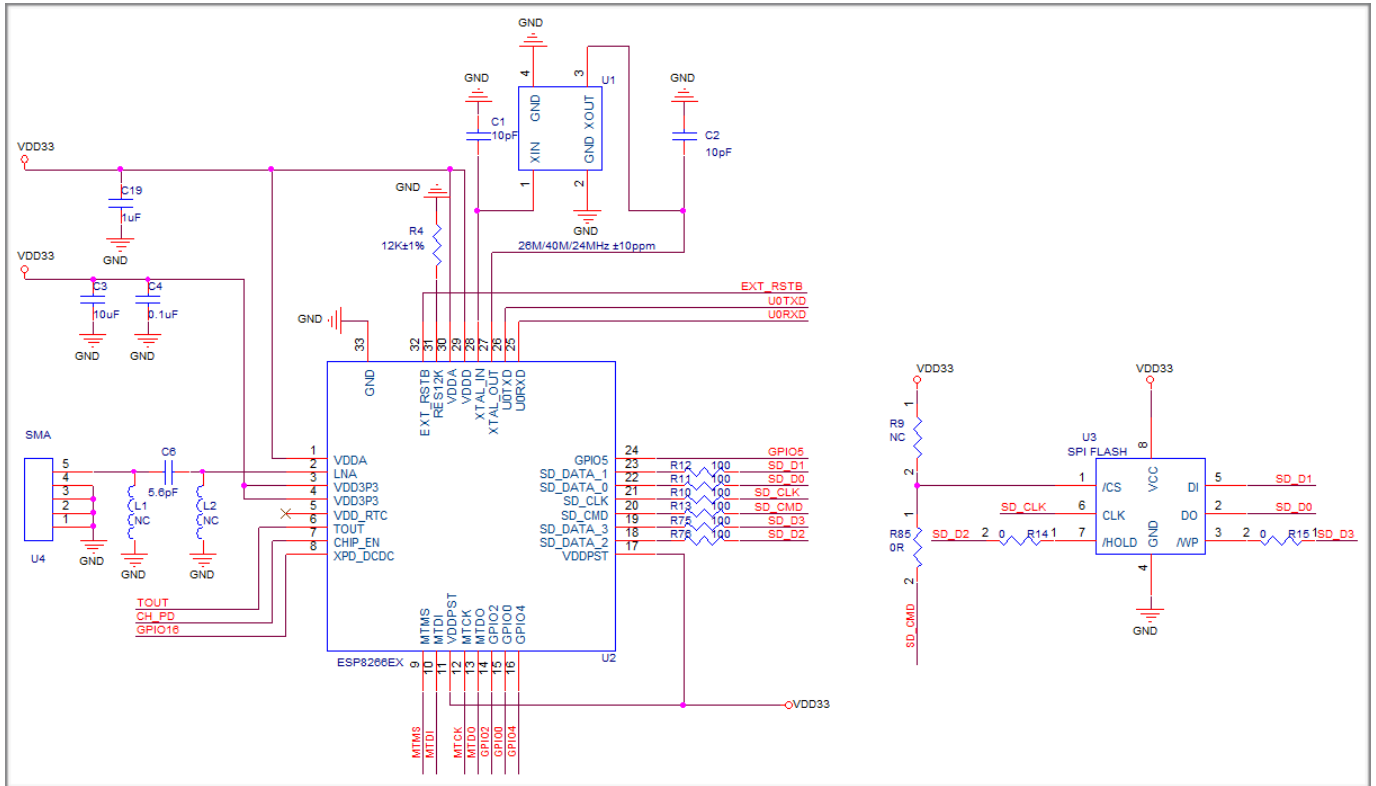



6.3. Schematics of ESP-WROOM Serial WiFi Modules

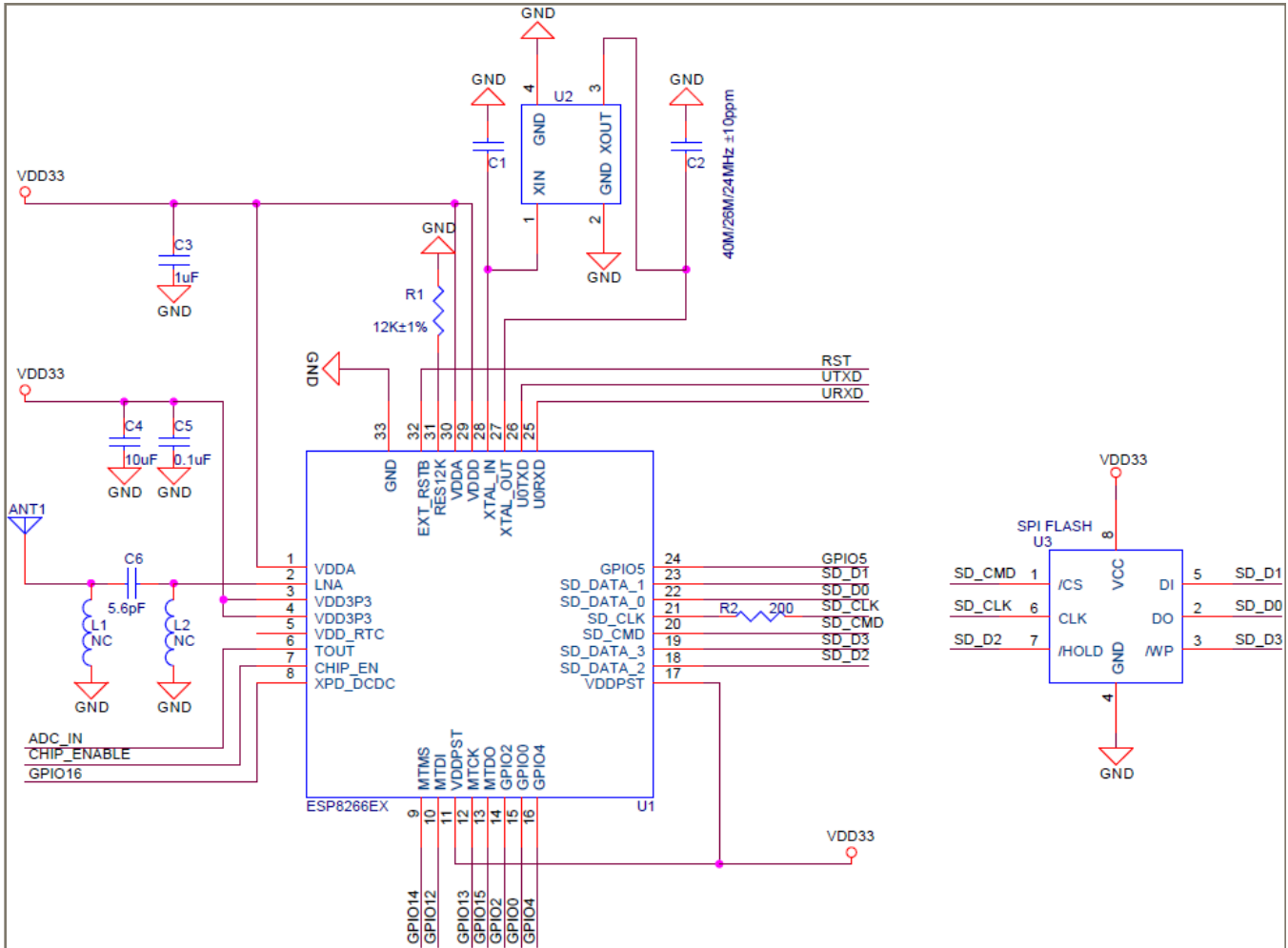



6.4. Schematics of ESP8266EX as SDIO/SPI Slave Device

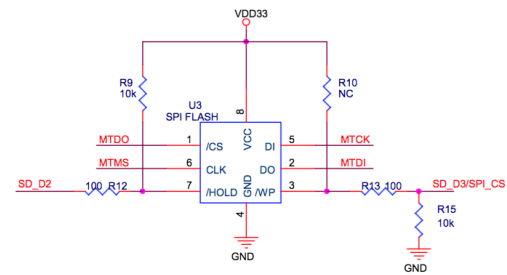
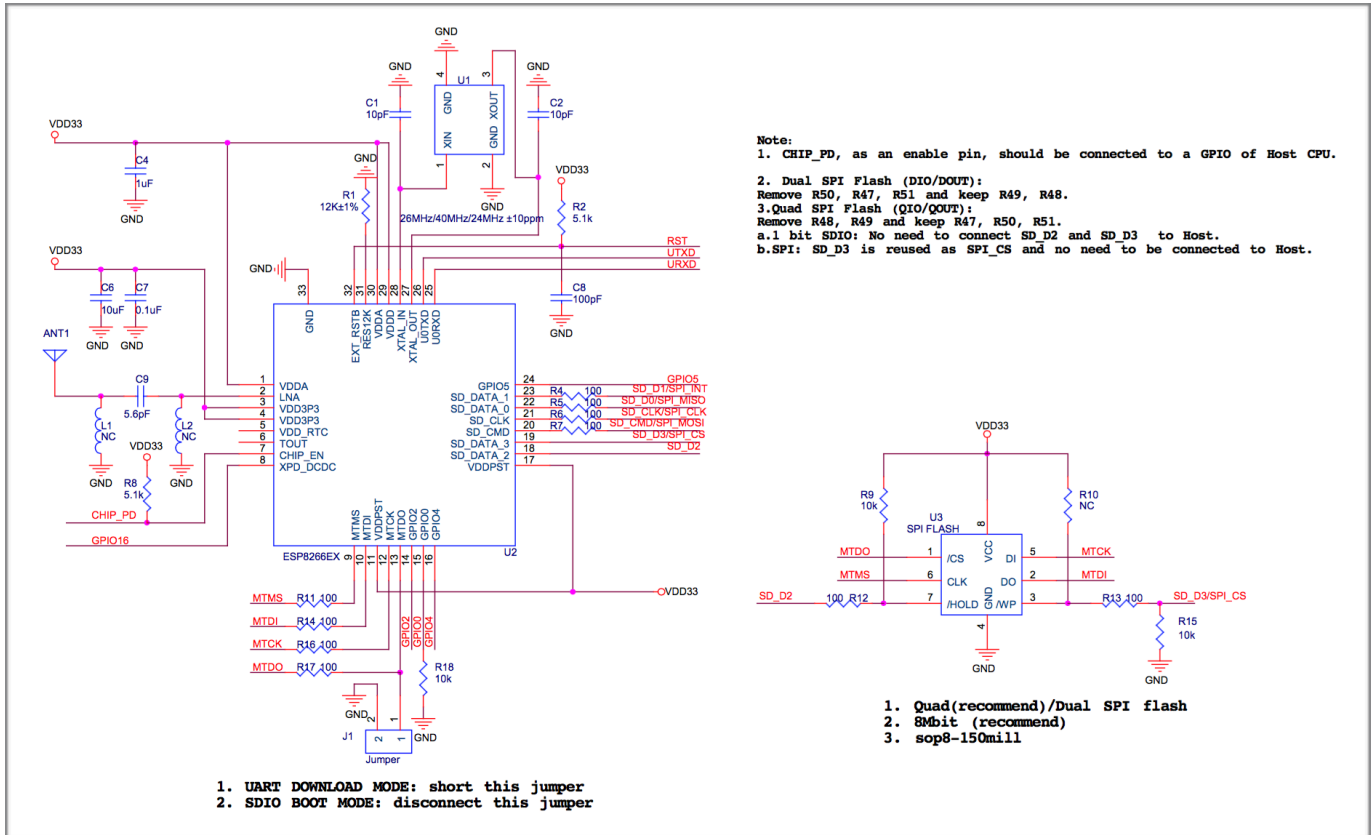

1. Quad(recommend)/Dual SPI flash
2. 8Mbit (recommend)
3. sop8-150mill