

## INSTRUCTION MANUAL

# *Air Conditioner*

*HB16 Series*

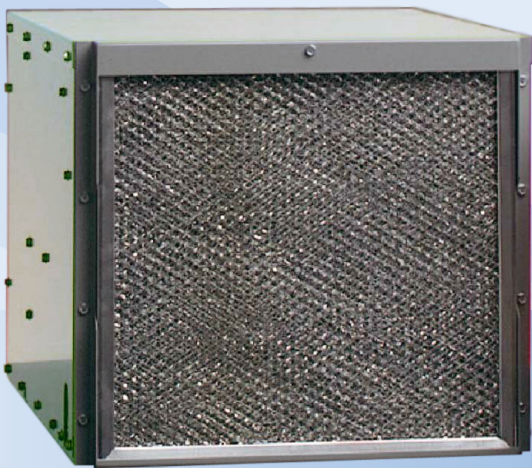

# **McLean<sup>®</sup>**

***Protecting Electronics.  
Exceeding Expectations.™***

Pentair Equipment Protection  
2100 Hoffman Way  
Minneapolis, MN 55303 USA  
☎ +1.763.422.2211  
📠 +1.763.576.3200

**PentairEquipmentProtection.com**



# TABLE OF CONTENTS

UNPACKING AND INSPECTING.....	2
HANDLING .....	3
HOW TO IDENTIFY YOUR HIBOY® AIR CONDITIONER.....	3
TECHNICAL INFORMATION .....	4
Design Data .....	4
Bench Testing.....	5
INSTALLATION INSTRUCTIONS.....	6
Mounting Inside of the Enclosure .....	6
Mounting on Top of the Enclosure.....	7
PRINCIPLES OF OPERATION .....	8
MAINTENANCE .....	9
Compressor.....	9
Inlet Filter.....	9
Condenser and Evaporator Blowers .....	9
Refrigerant Loss.....	9
How to Remove, Clean or Install a New Filter.....	10
Dimensional Drawings .....	11
Parts List.....	12
Accessories.....	12
Parts Exploded View .....	13
Wiring Schematic .....	14
Electrical Schematic.....	15
WARRANTY .....	18
HOLD HARMLESS.....	19

 <b>WARNING</b>
Read this manual thoroughly before attempting to install or test this HIBOY® air conditioner

## UNPACKING AND INSPECTING

Inspect the HIBOY® air conditioner. Check for concealed damage that may have occurred during shipment. Look for dents, scratches, loose assemblies, evidence of oil, etc. Any damage evident upon receipt should be noted on the freight bill. Damages should be brought to the attention of the delivering carrier within 15 days of delivery and NOT to Pentair Technical Products. Save the carton and packing material and request an inspection. Then file a claim with the delivering carrier.

Pentair Technical Products cannot accept responsibility for freight damages; however, we are ready to assist you in any way possible.

**NOTE: Some of the information in this manual may not apply if a special unit was ordered. If additional drawings for a special unit are necessary, they have been inserted. Contact Pentair Technical Products if further information is required.**

# HANDLING

To avoid possible shipping damage and facilitate transportation and storage, the HIBOY® air conditioner was shipped in a freight carrier tested corrugated container in its normal mounting position. After uncartoning, be certain that the air conditioner is placed in its normal upright mounting position for a minimum of five (5) minutes before operating, in order to allow the compressor oil to drain to the compressor sump area.

 **CAUTION**

Do not attempt to operate the air conditioner while it is horizontal or on its side, back or front. The refrigeration compressor is filled with lubricating oil. This will cause permanent damage to the air conditioner and also voids the warranty.

# HOW TO IDENTIFY YOUR HIBOY® AIR CONDITIONER

For installation and maintenance as outlined in this manual, first refer to the nameplate on your unit. The nameplate will provide important data regarding capacity of the unit, minimum and maximum ambient operating temperatures, type and amount of refrigerant required for recharging, and most important - electrical power characteristics when making electrical hook-ups or connections.

**ELECTRONIC ENCLOSURE**

**AIR CONDITIONER**

CUST. P/N			
MODEL NO.			
SERIAL NO.			
COOLING:		BTU	
HEATING:		BTU	
AMB. TEMP. MIN/MAX		°F	
PHASE		HERTZ	
VOLT			
REFRIGERANT		OZ.	
DESIGN PRESSURES P.S.I.G.		HIGH	
		LOW	

**USE A TIME DELAY FUSE OR CIRCUIT BREAKER**

11611 BUSINESS PARK BLVD. N., CHAMPLIN, MN 55316 USA  
 U.S. PATENT 4,027,498 DES. PAT. D252705 CANADA PATENTED 1979 1105702, OTHER U.S. & FOREIGN PATENTS PENDING

10-1002-05G
MADE IN U S A

When ordering service parts, specify these numbers.

Before installing, make certain these parameters are met. Lower or higher ambient temperatures may cause permanent damage or malfunction of the unit.

Before operating, make certain outlet and power source match these requirements.

Leak test pressures.

# TECHNICAL INFORMATION

## Design Data

<b>Model</b>	<b>Voltage</b>	<b>Hertz</b>	<b>Full Load Amps</b>	<b>Phase</b>	<b>BTU/Hr. @ Maximum Ambient Temperature</b>	<b>Maximum °F Ambient Temperature</b>	<b>Shipping Weight (lb. / kg)</b>
HB160816GXXX	115	50/60	18.8/20.4	1	7075/8133	131	145/66
HB160826GXXX	230	50/60	9.4/10.2	1	7075/8133	131	145/66
HB160846GXXX	460	50/60	5.2/5.6	1	7075/8133	131	160/73

## Bench Testing



### CAUTION

To avoid possible damage to the air conditioner, it must be in an upright operating position for a minimum of five (5) minutes before functional testing is started.

When “bench testing” the HIBOY® air conditioner before mounting to the electronic enclosure, follow the procedures outlined in the following paragraphs:

Make sure that the HIBOY® air conditioner is supported in a manner that assures free air flow out of and back into the openings which are located in the base tray.

Refer to nameplate for proper electrical current requirements, then connect the power cord to a properly grounded electrical outlet.

**NOTE: Minimum circuit ampacity should be at least 125% of the amperage shown in the DESIGN DATA table. To prevent overloading, no other equipment should be connected to this circuit.**

Make sure the unit has been in the upright operating position for at least five minutes.

Operate the air conditioner for five (5) or ten (10) minutes. No excessive noise or vibration should be evident during this run period. The condenser blower located in the rear section of the air conditioner, the evaporator or cool air blower located in the bottom of the unit, and the compressor should be running. To check cool air output, use a reliable air temperature measuring device. The cool air should be between 50 F (10 C) and 60 F (16 C) when room temperature is between 70 F (21 C) and 80 F (27 C).

You may remove the air inlet filter while checking the operation. The discharge line from the compressor (uninsulated line) should become very warm. Carefully touch this line to avoid possible burns. Condenser air temperatures should be warmer than normal room temperatures within a few minutes.

Mounted along the side of the compressor is the suction accumulator which is insulated to help avoid sweating or condensation buildup.

The compressor is provided with automatic reset thermal overload protection. This thermo switch is located and mounted inside the plastic enclosure clipped to the compressor. The only time this switch should operate is when the compressor overheats due to clogged or dirty inlet air filter, if ambient air temperatures exceed nameplate rating or if enclosure dissipated heat loads exceed the rated capacity of the air conditioner. The thermal overload switch will actuate and stop compressor operation. Blowers will continue to operate, however, and the compressor will not restart until the compressor has cooled to within the thermal overload cut-in temperature setting.

# INSTALLATION INSTRUCTIONS

## Mounting Inside of the Enclosure

1. Slide rails must be provided for supporting the rear portion of the air conditioner. Do not depend on the units mounting flange to support the entire weight. For mounting opening cutout dimensions, see Figure 2.
2. To protect the integrity of the closed-loop design (see PRINCIPLES OF OPERATION, page 8), adhesive backed gasket tape is provided (shipped loose) for sealing around the enclosure's air conditioner mounting opening. The gasket tape may be cut to length and either adhered to the air conditioner or to the enclosure as preferred.
3. The hot condenser air from the rear of the air conditioner must be ducted out of the enclosure. Openings and/or ducting must be of sufficient size to handle the air flow (25 in.<sup>2</sup> minimum). Keep in mind that reduction of air flow will impair air conditioner performance. Also remember that this air is hot and relatively dirty, therefore cracks and joints must be adequately sealed.
4. The drain tube which exits at the side of the air conditioner must be routed to the exterior of the enclosure. A copper "P" trap has been included in the drain system and must be properly primed and installed to prevent counter air flow into the drain system. A pressure relief fitting is also provided to vent any air blockage that may prevent proper drainage. The drain outlet must not be submerged nor any portion of the drain system elevated above the exit point of the air conditioner or overflowing of the condensate pan may occur.
5. Use of extension cords is not recommended.

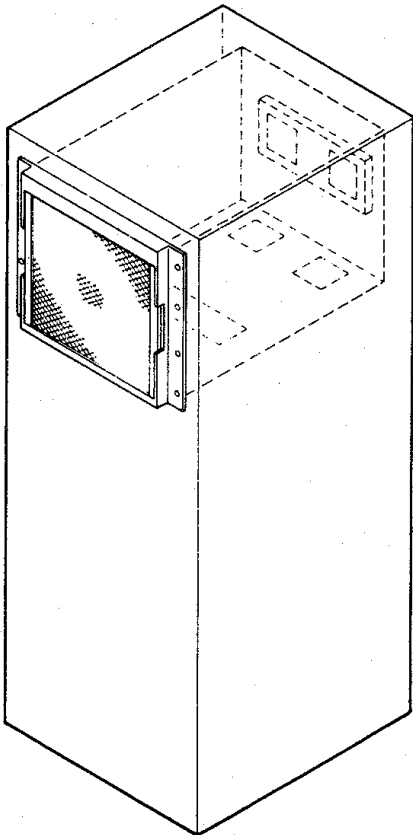

Mounted Inside Enclosure  
Figure 1

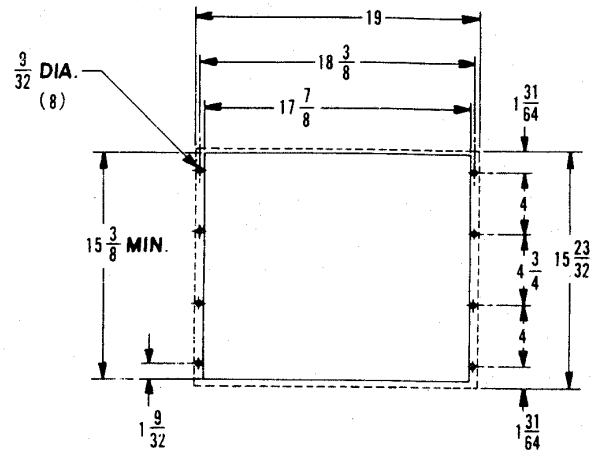

Cutout Dimensions for NEMA 12 Enclosures  
Dashed Lines Represent Air Conditioner  
Figure 2

## Mounting on Top of the Enclosure

1. Make sure the enclosure design is capable of supporting the air conditioner's weight. For interfacing air "IN" and "OUT" openings, refer to Figure 4. Also refer to Dimensional Drawings on page 11.
2. To protect the integrity of the closed-loop design (see PRINCIPLES OF OPERATION), adhesive backed gasket tape is provided (shipped loose) for sealing around the enclosure's cutout openings. The gasket may be cut to length and either adhered to the enclosure or to the air conditioner as shown in Figure 5.
3. A .5 inch (13 mm) inside diameter drain tube exists on the side of the air conditioner and must be routed over the side. A pressure relief fitting has been provided to assist in venting any air blockage that may prevent proper drainage. A copper "P" trap has also been included in the system and must be properly primed and installed to prevent counter air flow into the drain system. The drain outlet must not be submerged nor any portion of the drain system elevated above the exit point of the air conditioner or overlapping of the condensate pan may occur.

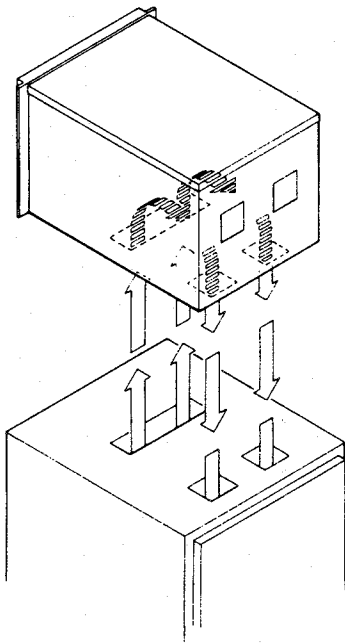

Mounted on Top of Enclosure  
Figure 3

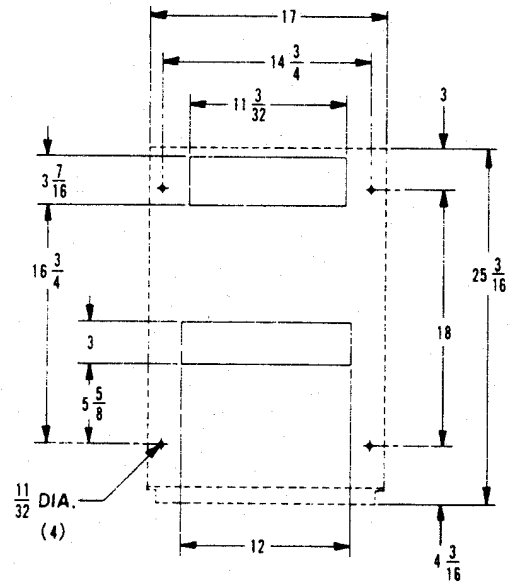

Cutout Dimensions for Top Surface Mounting  
Dashed Lines Represent Air Conditioner  
Figure 4

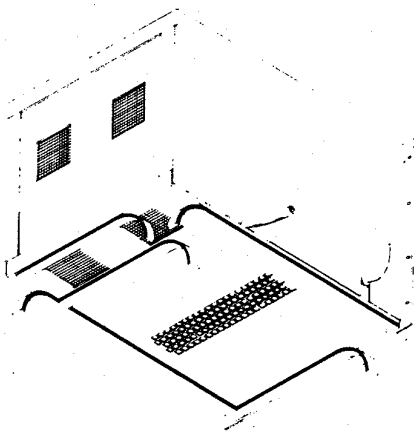

Gasket Installation  
Figure 5

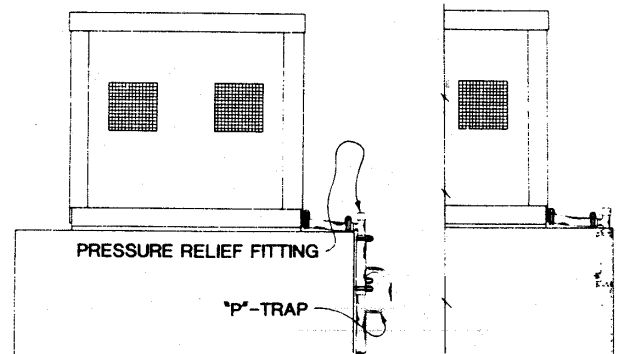

Outside of Enclosure      Through Enclosure  
Drain System  
Figure 6

## PRINCIPLES OF OPERATION

HIBOY® air conditioners are designed specifically to cool and dehumidify the internal environments of cabinets and enclosure which are used to package electronic components, thus assuring a cool, clean atmosphere for reasons of optimum performance and longevity.

Hot air inside the electronic enclosure or rack is removed and cooled by means of refrigeration. The hot air is drained from the enclosure interior through the evaporator air return opening in the bottom middle of the air conditioner. The air is drawn through the evaporator coil where it is cooled and discharged back to the enclosure interior through two evaporator outlet openings in the bottom rear of the unit. Any moisture in this air condenses on the evaporator coil and ultimately collects in the condensate tray where it is then discharged from the air conditioner via the condensate drain tube.

The closed-loop design of the air conditioner assures that this clean, cooled air never mixes with the hot, dirty ambient air that is used only for cooling the compressor and accomplish the heat exchange through the condenser coil. Generally the cabinet or enclosure air which is being cooled and recirculated over and over again does not require any filtering media.

Room or ambient air drawn into the air conditioner through the inlet filter, across the compressor and through the condenser coil is usually dirty, dusty and/or humid air depending upon the specific environment in which the air conditioner is required to operate. This ambient air is discharged by the condenser duplex blower back to the ambient environment. The temperature of this discharged air will be quite warm or actually hot depending on the ambient temperature and the work load imposed on the air conditioner.

Provided the inlet filter is properly maintained by frequent cleaning and/or replacement, the inlet filter will assure relatively clean air to pass through the condenser coil. Dirty filters will hamper the optimum operating efficiency of the air conditioner.

**NOTE: The condenser filter will require periodic maintenance, see MAINTENANCE on page 9.**

When the HIBOY® air conditioner is mounted in the enclosure or rack, it is recommended that an electrical lockout or safety switch be installed to interrupt operation of the unit while the enclosure door is opened.

If electrical power is momentarily interrupted to the air conditioner and reapplied immediately (within 3 to 5 seconds), the compressor may not restart due to the high back pressure of the compressor.

**DO NOT attempt to restart the air conditioner for at least one minute after the unit has been shut off either accidentally or intentionally.**

It takes at least one minute after shut-down for the compressor suction and discharge pressure to equalize in order to restart the air conditioner.

**Operating the HIBOY® air conditioner at ambient temperatures below the minimum or above maximum temperatures indicated on the nameplate will void all warranties.**

**It is recommended that the warranty section of this manual be read in order to familiarize yourself with parameters of restricted operation.**

It is very important to install the drain system in accordance with the installation instructions on page 7. By elevating the drain tube above the exit point on the air conditioner, you will cause the collected condensate or water to back up the drain tube and flood the condensate tray. This flooding or overflowing water could be transmitted into the electronic cabinet or enclosure by the air exhausted from the evaporator blower, thus causing damage to the expensive electronic components.

The moisture that the enclosure air can contain is limited. If moisture flows from the drain tube continuously, this can only mean ambient air is entering the enclosure. Remember frequent opening of the enclosures door admits humid air which the air conditioner must then dehumidify.



## MAINTENANCE

### Compressor

The compressor requires no maintenance. It is hermetically sealed, properly lubricated at the factory and should provide years of satisfactory operating service.

Should the freon charge be lost, recharging ports (access fittings) on the suction and discharge sides of the compressor are provided for recharging and/or checking suction and discharge pressures.

**Under no circumstance should the access fitting covers be loosened, removed or tampered with.**

Recharging ports are provided for the ease and convenience of reputable refrigeration repair service personnel for recharging the air conditioner, see Refrigerant Loss.

### Inlet Filter

Proper maintenance of the inlet filter will assure normal operation of your HIBOY® air conditioner. If filter maintenance is delayed or ignored, the maximum ambient temperatures under which the unit is designed to operate will be decreased.

As the compressor operating temperature increases above normal due to dirty or clogged inlet filter (or plugged condenser coil), the air conditioners compressor will stop operating due to actuation of the thermal overload cutout switch located on the compressor housing. As soon as the compressor temperature has dropped to within the switches cut-in setting, the compressor will restart automatically. However the above condition will continue to take place until the inlet filter has been cleaned or replaced.

It is recommended that power to the air conditioner be interrupted intentionally when abnormally high compressor operating temperatures cause automatic shut-down of the unit. The above described shut-down is symptomatic of a clogged or dirty filter, thus causing a reduction in cooling air flow across the surface of the compressor and condenser coil.

**Continued operation under the above conditions will damage and shorten the compressor life. The air conditioner features an easily removable inlet filter to facilitate necessary cleaning. There should be no reason to neglect this necessary maintenance.**

### Condenser and Evaporator Blowers

Blower motors require no maintenance. All bearings, shafts, etc. are lubricated during manufacturing for the life of the motor.



#### CAUTION

Operation of the HIBOY® air conditioners in areas containing airborne caustics or chemicals can rapidly deteriorate filters, condenser coils, blowers and motors, etc. Contact Pentair Technical Products for special recommendations.

### Refrigerant Loss

Your HIBOY® air conditioner was thoroughly tested before leaving the factory to insure against refrigeration leaks. Shipping damage or microscopic leaks not found with sensitive electronic freon leak detection equipment during manufacture may require repair and recharging of the system. This work should be performed by a qualified professional only, generally available in any reputable air conditioning repair or service company in your local area.

**Refer to the data on your nameplate which specifies the type of freon and the charge size in ounces.**

**Before recharging, make sure there are no leaks and the system has been properly evacuated by deep vacuum.**

## How to Remove, Clean or Install a New Filter

1. Lift the filter up so the bottom clears the lower filter retainer.
2. Pull the bottom of the filter out while pushing down until the top of the filter clears the upper retainer. If the unit is operating, carefully remove it assuring no dirt from the filter enter the air intake opening.
3. Follow the cleaning instructions shown in the graphic below.
4. Look at the air flow arrows on the filter for correct installation direction. Reinstall the cleaned filter (or a new filter) by sliding the top of the filter up into the upper retainer while pushing it against the unit. Finally, slide the filter down into the lower retainer.

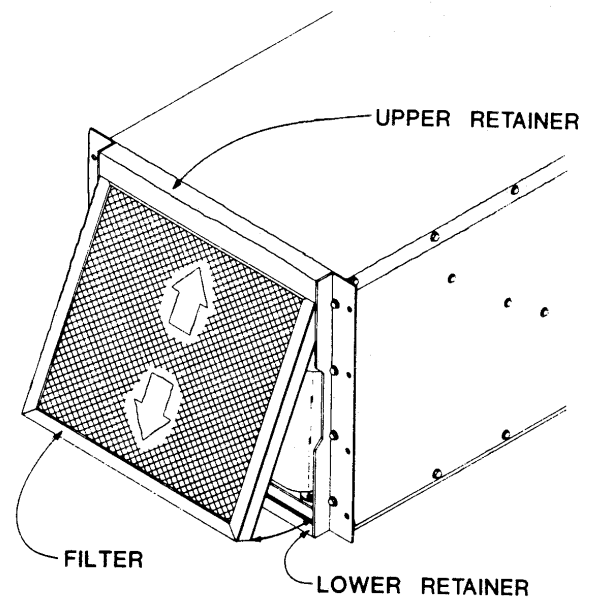

For replacement filter, disposable filters and filter adhesive, see parts list in Table 1 on page 12

### SERVICING AND CLEANING INSTRUCTIONS FOR **RP** AIR FILTERS

RP aluminum washable air filters are designed to provide excellent filtering efficiency with a high dust holding capacity and a minimum amount of resistance to air flow. Because they are constructed entirely of aluminum, they are light weight and easy to service. Optimum filter performance is maintained by recoating the filters after washing with RP Super Filter Coat adhesive. To achieve maximum performance from your air handling equipment, the air filter should be cleaned on a regular basis.

#### CLEANING INSTRUCTIONS

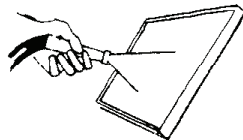

1. Flush the filter with warm water from the exhaust side to the intake side. DO NOT use caustics.

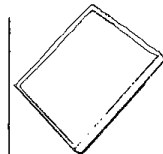

2. After flushing, allow filter to drain. Placing it with a corner down will assure complete drainage.

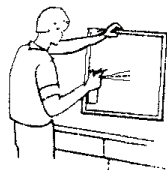

3. Recoat the filters with RP Super Filter Coat adhesive by dipping or spraying. If the filter is sprayed, do so from both sides for maximum concentration of adhesive.

# Dimensional Drawings

HB16 Models 8000 BTUs/Hr. (2051 Watts)

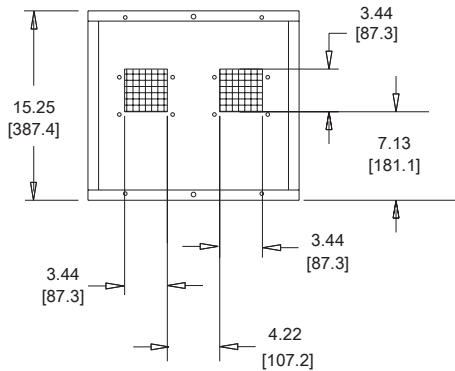

Rear View

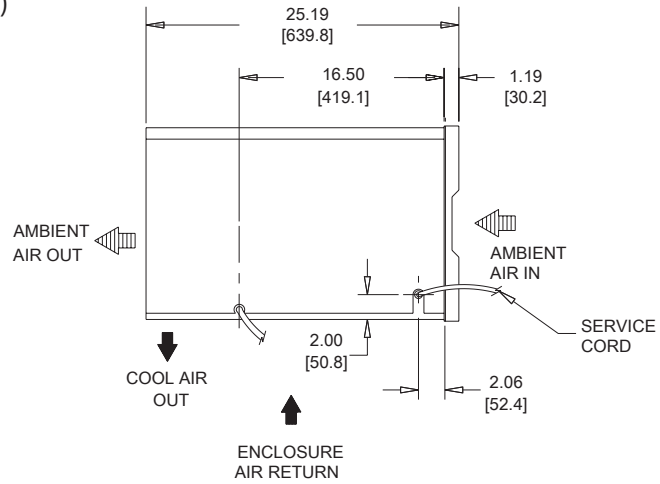

Side View

CLEANABLE,  
 REUSABLE  
 ALUMINUM  
 INLET FILTER

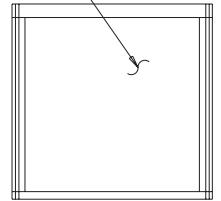

Front View

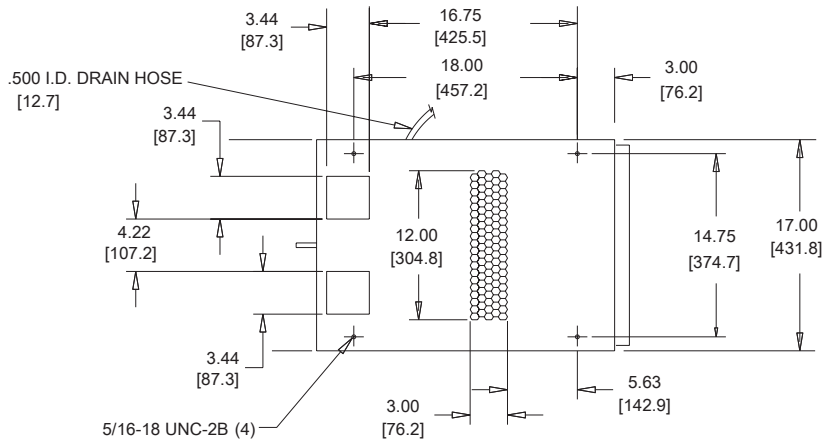

Bottom View

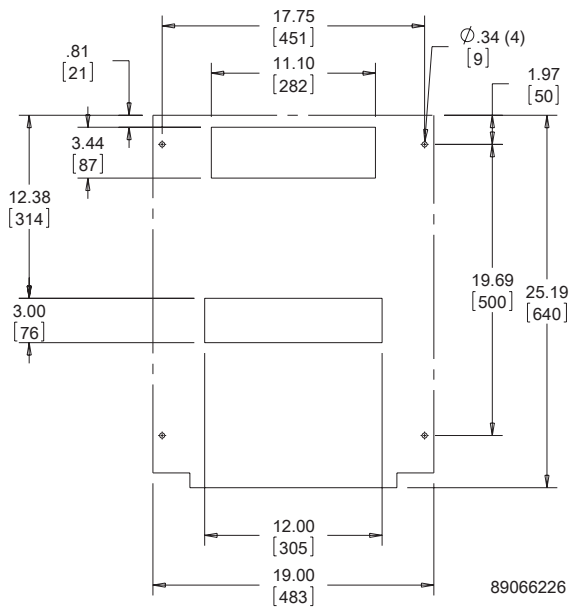

Cutout

## Parts List

(Specify model and serial numbers when ordering parts)

Item Number	Part Number	Quantity	Description
1	10-1000-08	1	Inlet Filter, Reusable Aluminum
9	16-7001-00	1	Coil, Condenser
16	52-6034-10M	1	Blower, Condenser (115 V)
	52-6025-10M	1	Blower, Condenser (230 V)
23	52-6075-00	1	Blower, Evaporator (115 V)
	52-6076-00	1	Blower, Evaporator (230 V)
26	52-6121-01	1	Coil, Evaporator (8000-9000 BTU/Hr.)
30	52-6058-05	1	Accumulator (230V Only)
35	See Table 1	1	Switch, Compressor Thermal Overload
38	See Table 1	1	Compressor
39	See Table 1	1	Power Cord
47	52-6028-00	1	Filter/Dryer, Refrigerant
48	52-6027-00	1	Valve, Hot Gas By-Pass (230V Only)
49	See Table 1	1	Capacitor, Compressor
N/A	10-1040-47	1	RFG, TXV (115V Only)

## Accessories

Part Number	Description
23512	Filter Coat - 1 pint Spray Dispenser

**Table 1**

Model	Item 35 Overload	Item 38 Compressor	Item 39 Power Cord	Item 49 Capacitor
HB160816GXXX	89097975	89043892	52-6035-85	52-6032-01
HB160826GXXX	10-1007-13	10-1026-115	52-6035-141	52-6031-01
HB160846GXXX	10-1007-13	10-1026-115	52-6035-135	52-6031-01

NOTE: For items listed but not shown, contact the factory..

# Parts Exploded View

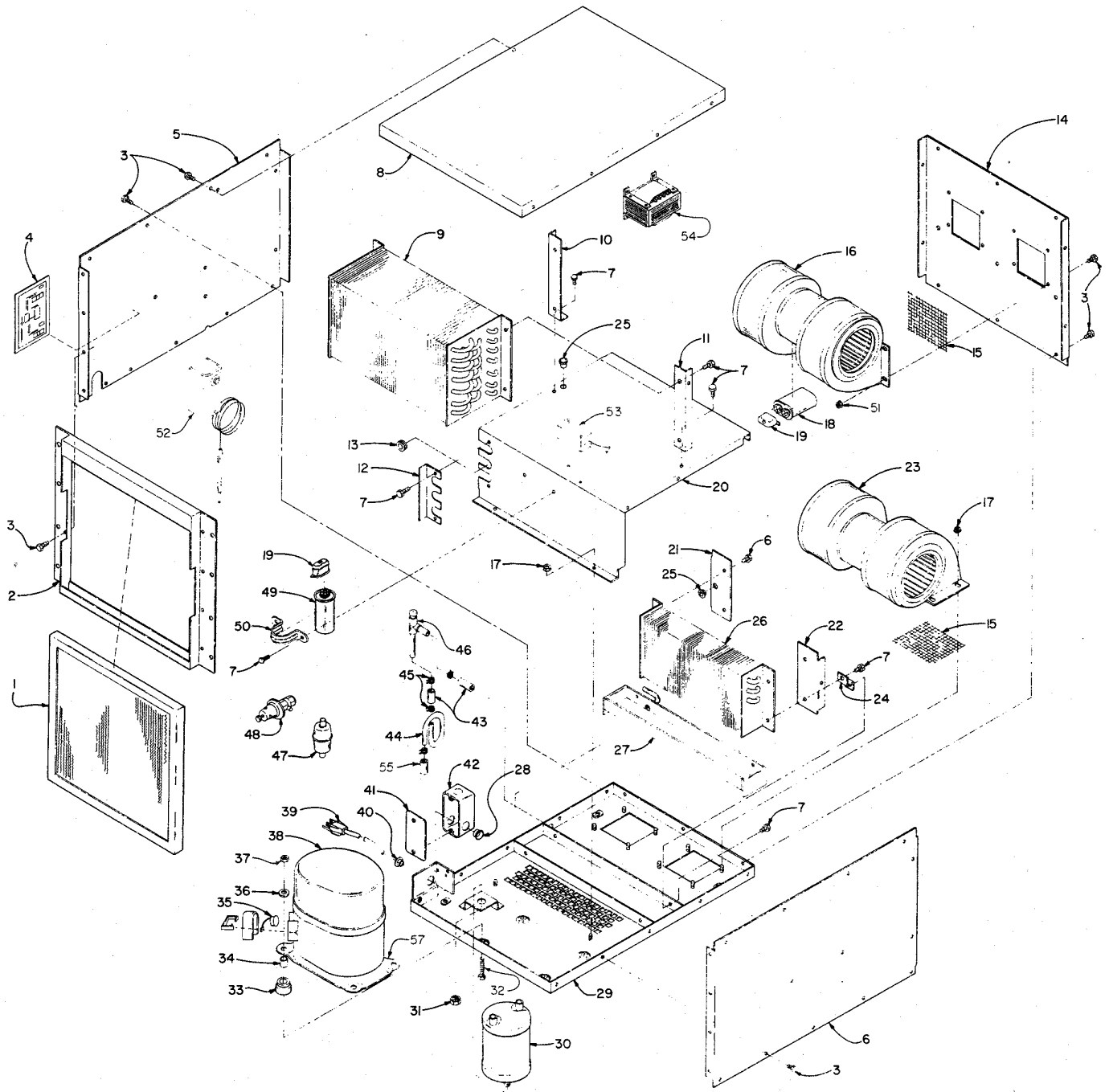

# Wiring Schematic

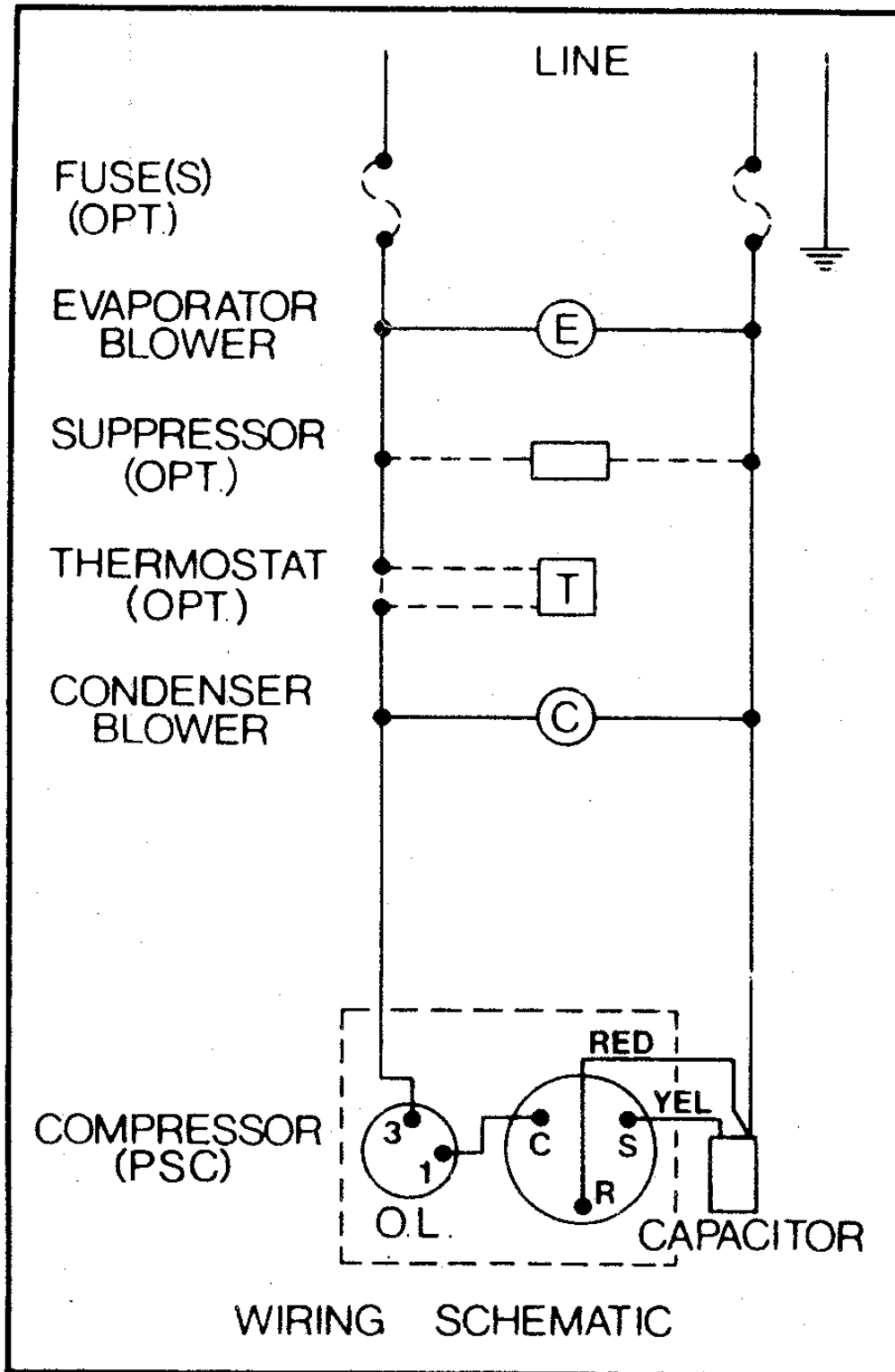

10-1001-01B

STANDARD  
230V

# Electrical Schematic

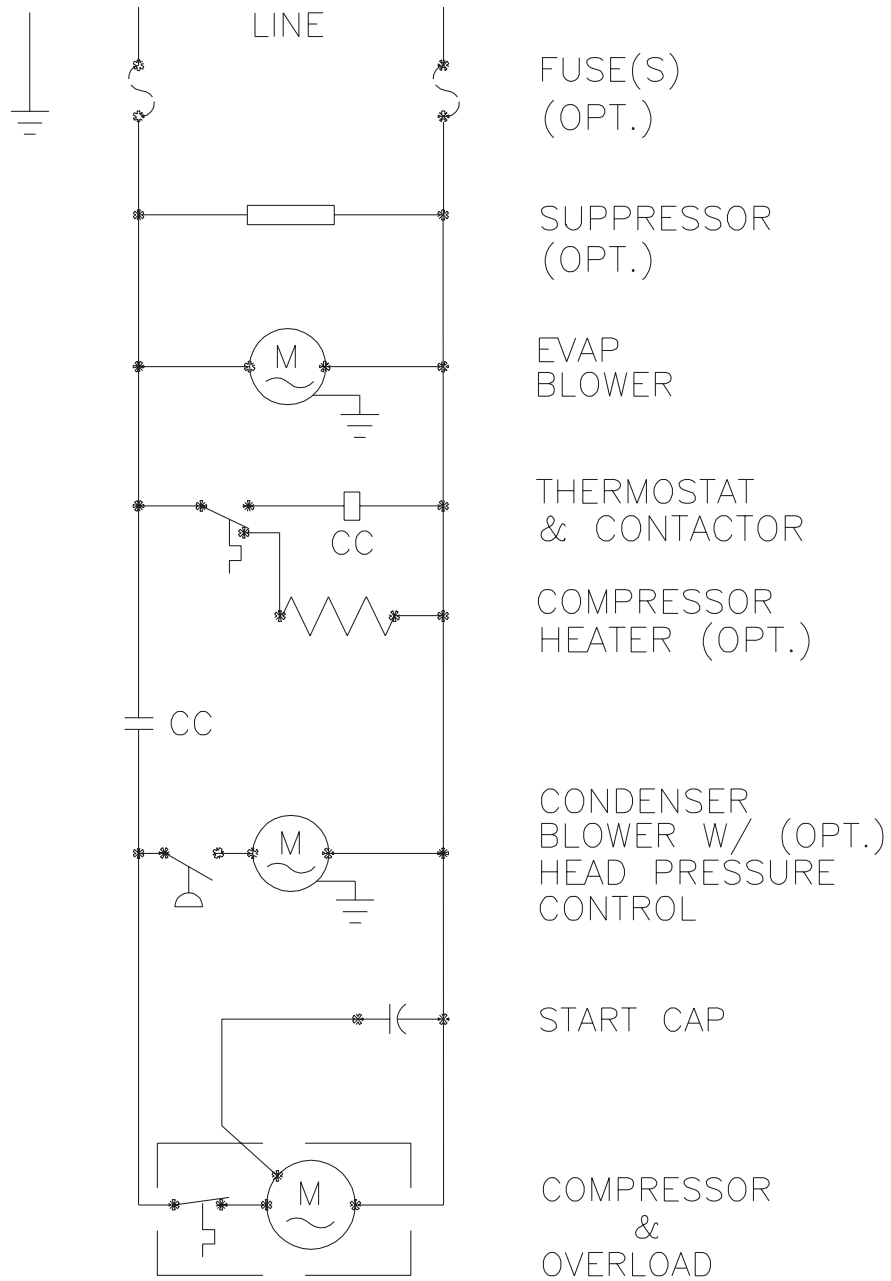

## ELECTRICAL SCHEMATIC

10-1001-667

## Notes



# Notes

## WARRANTY

Please note: Warranty effective at time of shipment. Pentair Technical Products warrants that all material and workmanship are free of defects in quality which impair the usefulness of the thermoelectric cooler or heat exchanger for a period of five (5) years for nonoperating parts, except for the filter; and for one (1) year for everything else when installed and operated under the following conditions:

- A. Maximum voltage variation no greater than plus or minus 10% of nameplate nominal rating.
- B. Maximum frequency variation no greater than plus or minus 3 Hz. of nameplate nominal rating.
- C. Must not exceed minimum and maximum stated temperatures on the nameplate.
- D. Not to exceed (BTU/Hr.) rating, including any heat sink, as indicated on the nameplate.
- E. The unit must not be restarted for a period of one (1) minute after intentional or accidental shut-off. (This does not apply to heat exchanger or filter fan.)

Pentair Technical Products warrants that all material and workmanship are free of defects in quality which impair the usefulness of the filter fan package and all custom thermoelectric coolers and heat exchangers for a period of one (1) year, except for the filter, when installed and operated under conditions A, B, C and D as listed above.

Not covered in this warranty is damage to the thermoelectric cooler or heat exchanger due to the introduction of other than the nameplate-designated refrigerant. Operation of any Pentair Technical Products product that has not been designed with proper protective coatings and/or options and is in an abnormal or corrosive environment voids the warranty. Prolonged operation with dirty filters also voids the warranty.

Should any part prove defective within the above warranty period, the customer may choose to return the defective product that is under warranty to Pentair Technical Products for repair at no charge or the customer has the option to repair the defective products at his own expense and Pentair Technical Products will supply repair parts at no charge providing the defective part is returned and found to have failed under warranty. Parts supplied as warranty replacement parts will assume the balance of the warranty on the part returned for warranty consideration.

Please be advised: According to the Federal Register, no person maintaining, servicing, repairing, or disposing of appliances may knowingly vent or otherwise release into the environment any class I or class II substance used as refrigerant.

Pentair Technical Products assumes no liability beyond the repair or replacement of its own product. Customer modification of any Pentair Technical Products product voids this warranty.

The purchaser assumes the responsibility of grounding the unit and installing it in accordance with local electrical and safety codes, as well as the National Electric Code (NEC) and OSHA.

This express warranty constitutes the entire warranty with respect to the PRODUCT and IS IN LIEU OF ALL OTHERS, EXPRESS OR IMPLIED, INCLUDING ANY WARRANTY OR MERCHANTABILITY AND WARRANTY OF FITNESS FOR A PARTICULAR PURPOSE AND IN NO EVENT IS PENTAIR TECHNICAL PRODUCTS RESPONSIBLE FOR ANY CONSEQUENTIAL DAMAGES OF ANY NATURE WHATSOEVER.

## **HOLD HARMLESS**

In consideration of purchase of equipment from Pentair Technical Products by a customer, Pentair Technical Products agrees to indemnify and hold harmless such customer and users with a defense, as to any claim, demand, statutory court cost, fees for attorney's services provided for below, and/or judgment, for actual or alleged patent infringement in any country, arising out of the use, sale or advertisement of any equipment manufactured or sold by Pentair Technical Products to Pentair Technical Products's own specifications, provided that the customer or user shall promptly notify Pentair Technical Products in writing of any such claim or demand, provided further that Pentair Technical Products shall have the right and option to undertake and control the entire defense of such claim, or demand instituted against the customer or user, but limited to the products made or sold by Pentair Technical Products, through counsel selected by Pentair Technical Products, and to settle and pay any claim award arising out of such claim or demand, and provided further that the customer or user will provide such information and assistance as Pentair Technical Products may request subject to reimbursement by Pentair Technical Products for any out-of pocket expense incurred in providing such requested assistance. Liability of Pentair Technical Products for any infringement or claim thereof shall be limited to the above undertaking.

# **McLean<sup>®</sup>**

***Protecting Electronics.  
Exceeding Expectations.™***

Pentair Equipment Protection  
2100 Hoffman Way  
Minneapolis, MN 55303 USA  
☎ +1.763.422.2211  
📠 +1.763.576.3200

**[PentairEquipmentProtection.com](http://PentairEquipmentProtection.com)**

