

SCREW: N/A	MATERIAL: L022 227	CELL: CSP	TOLERANCES-UNLESS OTHERWISE SPECIFIED 2 PL. DEC. ±.015 TRUE CL. ±.015 3 PL. DEC. ±.015 ANGLES ±1	
CAT. NO.: SEE CHART	PLATING: EL-TIN	INFORMATION SHT: FORM 196	DWG. NO. YA1003-YAN1003-2H	
MASS: SEE CHART	MARKING: NO TANG MARKING	DATE: 5/30/2013	SCALE: NTS	SHEET 1 OF 3
SURFACE AREA: 2			SIZE: B	
REV. I		DESCRIPTION		APPROVED BY

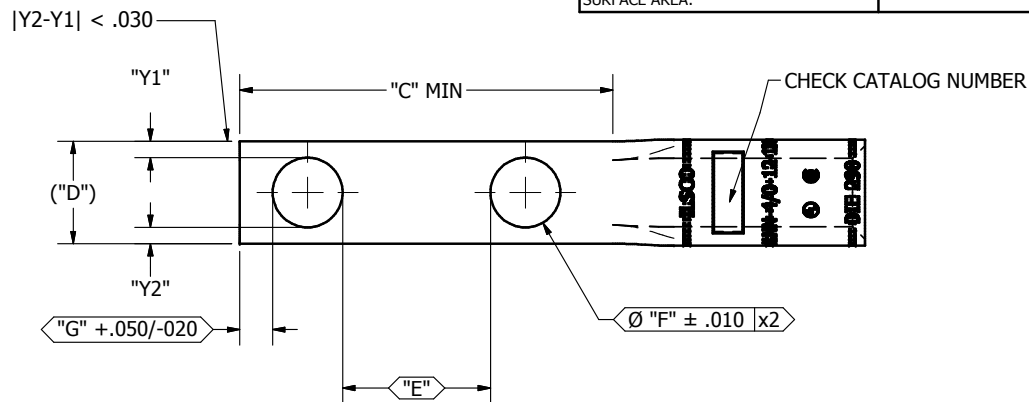

CAT #: SEE CHART FOR COMPLETE CAT #'S

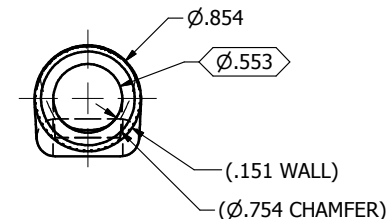
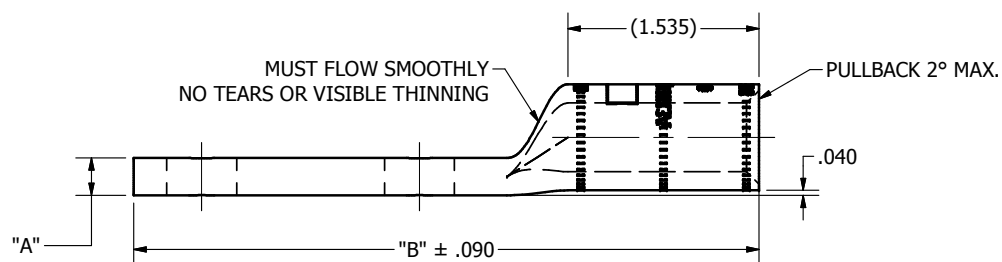
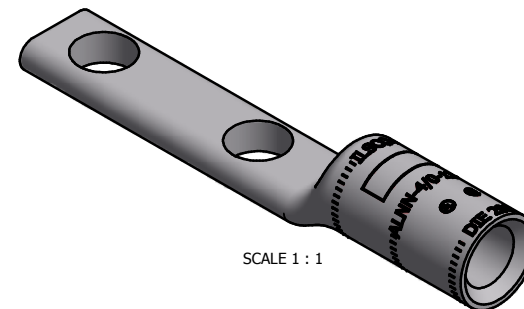

Catalog Number	Part Number	Saw Cut	"A"	"B"	"C"	"D"	"E"	"F"	"G"	Mass (lbs.)
ALND-4/0-38-1	YA1003C64T	4.120	0.301	4.120	2.005	1.170	0.594	0.406	.211	.120
ALNN-4/0-38-1	YAN1003C64T	3.960	0.327	4.126	1.930	0.810	0.594	0.406	.211	.098
ALND-4/0-38-134	YA1003C67T	4.800	0.301	4.800	2.668	1.170	1.344	0.406	.211	.142
ALNN-4/0-38-134	YAN1003C67T	4.451	0.336	4.815	2.620	0.810	1.344	0.406	.211	.113
ALND-4/0-12-1	YA1003C69T	4.300	0.301	4.300	2.177	1.170	0.438	0.562	.265	.119
ALNN-4/0-12-1	YAN1003C69T	4.160	0.330	4.313	2.127	0.811	0.438	0.562	.265	.119
ALND-4/0-12-134	YA1003C72T	5.195	0.301	5.195	3.044	1.170	1.188	0.562	.265	.148
ALNN-4/0-12-134	YAN1003C72T	5.226	TBD	5.026	TBD	0.824	1.188	0.562	.265	.114

THE INFORMATION CONTAINED WITHIN THIS DOCUMENT IS PROPRIETARY TO ILSO AND MAY NOT BE DISCLOSED WITHOUT PRIOR WRITTEN CONSENT