

Protective Cooling Catalog

EDITION 10.2e

*Air Conditioners, Heat Exchangers &
Engineered Solutions for Closed-Loop
Electronic Systems*



McLean[®]
COOLING TECHNOLOGY

*Protecting Electronics.
Exceeding Expectations.™*



Pentair
Technical Products

Quick Reference

Use this handy table to match your electronic cooling requirements with the most effective McLean protective cooling solution.

HOW TO SELECT

SYSTEM APPLICATION	Air Conditioners					Heat Exchangers	
	New SPECTRACOO [™] Pages 20-39	GENESIS [®] Pages 76-101	PROAIR Pages 104-113	T-Series [™] Pages 42-73	Water-Cooled Pages 116-123	PROAIR Pages 126-141	CLIMAGUARD [™] Pages 144-157
For indoor industrial							
For harsh / corrosive environments							
For wash-down applications							
For data networking cabinets							
For outdoor enclosures							
For telecommunications shelters							
TEMPERATURE OF THE ELECTRONICS							
Cooler than outside the enclosure							
Warmer than outside the enclosure							
AIR CONDITIONER COOLING CAPACITY							
1000/2000 BTU/Hr. (300/700 Watts)							
4000/6000 BTU/Hr. (1200/1800 Watts)							
8000/12000 BTU/Hr. (2300/3500 Watts)							
20000 BTU/Hr. (5900 Watts)							
2-ton 23500 BTU/Hr. (6900 Watts)							
3-ton 42000 BTU/Hr. (12300 Watts)							
5-ton 59000 BTU/Hr. (17300 Watts)							
HEAT EXCHANGER COOLING CAPACITY							
Less than 20 Watts/°F (30 Watts/°C)							
20-60 Watts/°F (30-100 Watts/°C)							
More than 60 Watts/°F (100 Watts/°C)							
POWER INPUT							
115 & 230 AC Volt							
400/460 AC Volt 3-phase							
24 & 48 DC Volt							
MOUNTING							
Side							
Top							
Rack							
CABINET PROTECTION							
Type 12							
Type 3R							
Type 4							
Type 4X Stainless Steel							
CABINET DIMENSION							
Fits 8 in./203 mm							
Fits 12 in./305 mm							
Fits 16 in./406 mm							
Fits 20 in./508 mm or larger							

Table of Contents

New Product Overview

SPECTRACOOL™ Indoor and Outdoor Air Conditioners	2
CLIMAGUARD™ Outdoor Heat Exchanger.	3

Why Use Pentair Technical Products 4

Why Use McLean Cooling Technology 5

How To Select A Protective Cooling Solution

Protective Cooling Solution Overview	
Why Cool Electronics in the First Place?.....	6
Heat Ruins Electronics	6
Sources of Heat.....	6
Trend Toward More Damaging Heat.....	6
What Are the Consequences of Damaging Heat?	6

Options for Cooling Electronics	
Conductive Cooling	7
Fresh Air Cooling	7
Protective Cooling.....	7

Levels of Electronic Enclosure Protection	
Protection Levels	8
SCCR Requirements per UL (Condensed version)	9

Selecting the Right Cooling Solution	
Cooling Solution.....	10
Cooling Solution Choices	11

How to Select the Right Cooling Capacity Air Conditioner	
Air Conditioner Cooling Capacity Overview	12
Part A: How to Determine Internal Heat Load.....	12
Part B: How to Determine Heat Transfer Load Overview.....	13
Simple Chart Method	13
How to Determine Total Heat Load.....	14
Equation Method.....	14

How to Select the Right Cooling Capacity Heat Exchanger	
Heat Exchanger Cooling Capacity Overview.....	15
How to Determine Internal Heat Load.....	15
How to Determine Heat Transfer	15
How to Determine Heat Exchanger Capacity	16

SPECTRACOOL™ Indoor and Outdoor Air Conditioners

G28 Indoor/Outdoor Base Models.....	20
G28 Models 4000/6000 BTU	21
G52 Indoor/Outdoor Base Models.....	26
G52 8000/12000 BTU	27
G57 Indoor/Outdoor Base Models.....	34
G57 Models 20000 BTU.....	35

T-Series Indoor/Outdoor Air Conditioners

Indoor/Outdoor Air Conditioners	42
T15 Model 800 BTU	43
T20 Model 2000 BTU.....	46
T29 Model 4000 BTU.....	49
T43 Model 6000 BTU.....	52
T43 Model 8000 BTU.....	54
T43 Model 10000 BTU.....	56
T50 Model 12000 BTU.....	59
T53 Model 19000 BTU	62
T62 Model 20000 BTU.....	65
T70-36 Model 36000 BTU	68
T70-60 Model 59000 BTU	71

GENESIS® Indoor Air Conditioners

Indoor Air Conditioners.....	76
M13 Models 1000 BTU	77
M17 Models 1800 BTU	79
M28 Models 2200 BTU	81
M28 Models 4000 BTU.....	82
M28 Models 6000 BTU.....	83
M33 Models 4000 BTU	85
M36 Models 6000 BTU	87
M52-3 3-Phase Models 4100-10000 BTU	89

GENESIS® Top-Mount Air Conditioners

Top-Mount Air Conditioners	94
MHB11 Models 2200 BTU.....	95
MHB11 Models 4000 BTU	96
HB16 Models 8000 BTU	98

PROAIR Harsh Environment/Wash Down Air Conditioners

Harsh Environment/Wash Down Air Conditioners	104
CR23 Model 1600 BTU	105
CR29 Model 2200/4000 BTU	108
CR43 Model 6000/8000 BTU	111

Water-Cooled Air Conditioners

Water-Cooled Air Conditioners.....	116
33WC Model 4000 BTU.....	117
CR43WC Model 8000 BTU.....	119
LB11WC Model 4000 BTU.....	121

PROAIR Indoor Heat Exchangers

Indoor Heat Exchangers	126
XR20 Model	127
XR29-08 Model	129
XR29-18 Model	131
XR47-24 Model.....	133
XR47-35 Model	135
XR60-55 Model	137
XR60-84 Model.....	139

CLIMAGUARD™ Outdoor Heat Exchangers

Outdoor Heat Exchangers	144
TX23 Outdoor Model	145
TX33 Outdoor Model	148
TX38 Outdoor Model	151
TX52 Outdoor Model	154

After-Market Customer Support

Engineered Solutions	158
----------------------------	-----

Model Number Index..... 160

Abbreviations.....163

Aftermarket Services - Global Field Repair Network.... 164



SPECTRACOOL™ Indoor & Outdoor Air Conditioner

Makes electronics cooling easier, so you can go about your business

Calm, cool and collected

EARTH-FRIENDLY

- Rotary compressor delivers up to 50% greater energy efficiency
- R134a earth-friendly refrigerant
- Produces 68 dB(A), quieter than other traditional air conditioners
- RoHS compliant

EASY INSTALLATION

- 30 pounds (14 kilograms) lighter than the T50 Outdoor Air Conditioner
- UL Listed, saving customers time and money by having agency approvals
- Built-in installation hooks on the back of each unit
- Cut-out adapters for enclosures with GENESIS® and T-Series Air Conditioners, enabling users to easily transition to the new models

CLEAN APPEARANCE

- Attractive industrial design
- Minimal use of visible fasteners
- ANSI 61 gray powder-coat paint in a semi-texture finish
- Other paint colors and textures available

VERSATILE COOLING

- Indoor and outdoor models
- 4000, 6000, 8000, 12000 & 20,000 BTU/Hr. (1100, 1700, 2300, 3500 & 5900 W) of cooling
- 115, 230 and 460 3-phase AC volt power input with +/- 10% operating range
- Exterior and partially recessed mounting options

RELIABLE PERFORMANCE

- Operating temperature range:
 - -40 F/-40 C to 131 F/55 C outdoor
 - 50 F/10 C to 131 F/55 C indoor
- UL Type 12/3R/4 rated and Telcordia GR-487 capable
- IP34 rated for incoming ambient air
- IP56 rated for air moving from the AC into the enclosure
- Type 4X stainless steel option available
- All-metal shroud to better withstand rugged factory and outdoor environments
- Dual condenser-side air movers for performance redundancy
- Washable metal filter to keep coil clean for maximum performance
- Made in an ISO 9001 certified facility
- Thoroughly tested during engineering development to withstand vibration and perform in virtually any environment
- Every unit functionally tested before shipping

EASY TO SPECIFY

- Standard Indoor air conditioner has:
 - Condensate management heater strip
 - Power-off relay for door switch
 - Malfunction switch
- Standard outdoor air conditioner has:
 - Telcordia GR487 capability
 - Corrosion-resistant components
 - Malfunction switch
 - Compressor heater
 - Head pressure control
 - 2000 W enclosure heater

RESPONSIVE CUSTOMER SERVICE

- Popular models in-stock, ready for immediate shipment
- Backed by a 2-year standard warranty
- Over 1000 field repair technicians worldwide
- Secure and easy-to-use online spare parts store

SPECTRACOOL's Key Advantages

- 1** UL Listed, saving customers time and money by having agency approvals
- 2** Built-in flanges on back and 30 lb. (14 kg) lighter for easy installation



3 R134a rotary compressor for greater energy efficiency and environmental friendliness

- 4** Clean attractive design, adding value to the electronic system's aesthetics
- 5** Rugged all-metal shroud for demanding factory and outdoor environments



6 Dual condenser-side impellers for performance redundancy

- 7** Easy-to-access metal filter and other components for fast service and less system downtime

Type 12/3R/4 Type 4X optional



CLIMAGUARD™ Outdoor Heat Exchanger

Lab- and field-tested to seal out harsh environments

Stands tough against mother nature

EARTH-FRIENDLY

- Consumes less energy than traditional air conditioners
- RoHS compliant

VERSATILE COOLING

- Removes up to 3000 W of enclosure heat
- Works with 24 VDC, 48 VDC, 115 VAC and 230 VAC power input
- Surface- and recess-mount options
- Up to 2000 W heater selection on DC and AC volt models

RUGGED DESIGN

- Engineered for extreme climate conditions
 - -40 F/-40 C to 149 F/65 C operating temperature range
- UL Type 12/3R/4 rated and Telcordia GR-487 capable
- Powder-coated galvanized sheet metal shroud
- UL Type 4X stainless steel option available
- Corrosion-resistant aluminum core

RELIABLE PERFORMANCE

- Every core double-sealed for maximum weather protection
- Few moving parts
- Made in an ISO 9001 certified facility
- Every unit functionally tested

Goes easy on human nature

QUIET

- Variable-speed blowers standard on DC-powered units for quieter operation

EASY TO USE

- UL Listed, saving customers time and money by having agency approvals
- Built-in installation hooks on the back of each unit
- Filterless capable for most operating environments

RESPONSIVE CUSTOMER SERVICE

- Popular models in-stock, ready for immediate shipment
- Backed by a 2-year standard warranty
- Over 1000 field repair technicians worldwide
- Secure and easy-to-use online spare parts store

Type 12/3R/4 Type 4X optional

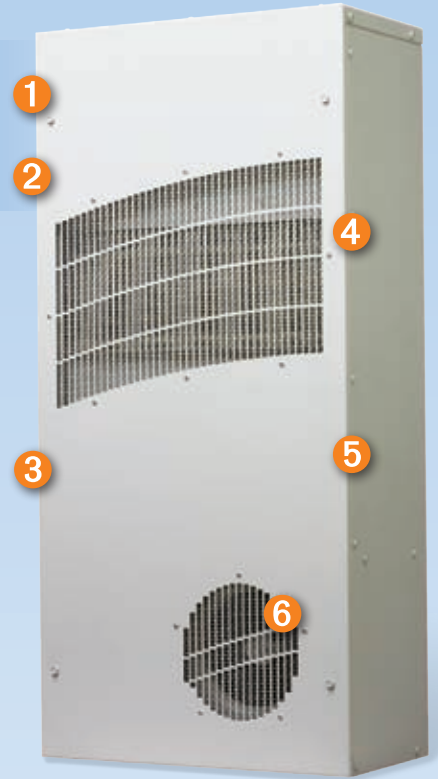

CLIMAGUARD's Key Advantages

- 1 UL Listed, saving customers time and money by having agency approvals
- 2 Built-in hooks to hang unit before fastening to cabinet for easier installation
- 3 DC- and AC-volt power input options to work in a variety of systems without power conversion

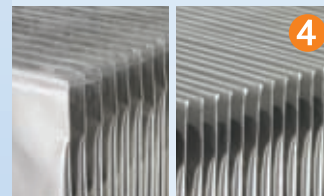

4 Double-sealed core for maximum protection against extreme weather

- 5 Powder-coated galvanized metal construction with stainless steel option that stands up to harsh environments
- 6 DC-volt models operate at variable speeds, producing less noise



No company engineers and services cooling solutions for vital electronics better than
Pentair Technical Products

With more than 30 years of experience producing everything from fan assemblies to standard air conditioners and heat exchangers to engineered cooling applications for one-of-a-kind systems, the Pentair Technical Products McLean brand has the people and products to deliver the cool. The markets we serve include industrial automation, food and beverage, telecommunications, petrochemical, transportation, data networking, security and defense, and many others.

Pentair Technical Products understands your need for performance and does whatever it takes to ensure that when you make a promise to a customer, you can keep it.

**Pentair Technical Products
Awarded for Exceptional
Customer Service by Northrop
Grumman, A Premier U.S.
Defense Contractor**

Pentair Technical Products received a 2008 Customer Service Award from Northrop Grumman for exceptional performance on critical Homeland Defense contracts. The Northrop Grumman award recognized select vendors who play a critical role in helping the company successfully fulfill its US government and other major contracts.

Northrop Grumman selected the McLean brand to provide the cooling solution for the Biohazard Detection System (BDS) developed for the US Postal Service. Part of the project's challenge included managing the heat load generated from the sensitive electronics utilized in the system and from varying environmental conditions.

"The Pentair Technical Products team stepped up to the challenge with the development of an air conditioner that had the right level of cooling, service life and other key features. They also provided the post-deployment service support that was needed," said Ann Schofield, BDS programs director at Northrop Grumman. "Our entire supplier experience with Pentair Technical Products proved to be exceptional, leading us to select them for the service award."

The Northrop Grumman award affirmed the customer-focused culture at Pentair Technical Products. Some companies put customer service in their mission statements; Pentair Technical Products actually lives by it.



PRODUCT SELECTION

Indoors or out, McLean air conditioners, heat exchangers, air movers and controls get the job done.



CUSTOM COOLING SOLUTIONS

An experienced staff with advanced software, rapid prototyping and in-house test facilities delivers custom cooling solutions quickly and to your exact specifications.



**TECHNICAL EXPERTISE
AND SUPPORT**

With over 30 years of experience across dozens of industries, our engineers are able to assist your project design every step of the way. We also put that same cooling know-how into the standard platform solutions that we develop for the broader market.



Why Use Pentair Technical Products McLean Brand Cooling Technology

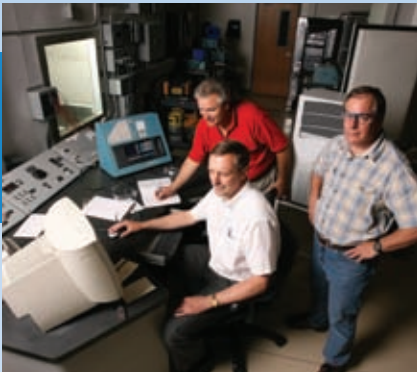

PRODUCT RELIABILITY

Speak with McLean customers, and you'll discover a strong market reputation for product reliability. We are ISO 9001:2008 certified. Every unit is also functionally tested before shipping.



EXPERIENCED SALES STAFF

Years of cooling systems expertise, engineering knowledge and responsive problem solving help our sales staff "listen, learn, develop and deliver."



COOL CUSTOMER SUCCESSES

Thomson and McLean Are Shaken, But Not Stirred

Thomson Broadcasting is the world leader in digital video technologies. That's why top media, entertainment and communications companies turn to Thomson to get the right images to the right place at the right time – over time.

And that's why Thomson turns to the McLean brand to help keep its customers' broadcast systems up and running 24 hours/7 days.

"We recently tested a new UHF base station for one of our clients," said Don Wike, Chief Design Engineer. "We put our system, including a McLean outdoor air conditioner, through a pretty rigorous Telcordia GR487 test protocol. We shook the UHF system, dropped it from over 45 cm, and simulated years of cold winters and hot summers in a cycle chamber. After all this, the McLean unit still performed beautifully."

Don added, "Our customers count on Thomson to design a rugged digital media system. And we count on McLean to keep the electronics cool. We had over 8000 W of heat to dissipate in the new UHF base station system. The McLean 3-ton A/C unit proved it can handle the load. Pentair Technical Products also allowed us to use their thermal cycle test chamber, saving us R&D costs."

For electronics cooling that performs under extreme conditions, take a serious look at McLean. More cool customer stories are available at McLeanCoolingTech.com



ONLINE PARTS ORDERING

An easy-to-navigate online parts store provides fast, secure replacement part ordering 24 hours/7 days.



FISCALLY STRONG

The Pentair Technical Products McLean brand is owned by Pentair, a US \$2.7 billion diversified, publicly held global operating company. We handle single-unit in-stock orders to US \$5 million+ global projects.



GLOBAL REACH

McLean's growing worldwide network of sales, distribution and manufacturing delivers quality service for those who need global infrastructure.



SUPERIOR SERVICE AND REPAIR

Over 1000 certified repair technicians provide 24-hour emergency service worldwide.

Why Cool Electronics in the First Place?

Keeping your electronics cool is essential to extending their life and keeping your business running.

Heat Ruins Electronics

The life expectancy of electronics is cut in half every 10 C / 18 F they operate above room temperature. Operating electronics above certain temperatures can void manufacturers' warranties, making proper cooling essential. Cooling vital electronics increases service life and reduces capital expenses over the long-term.

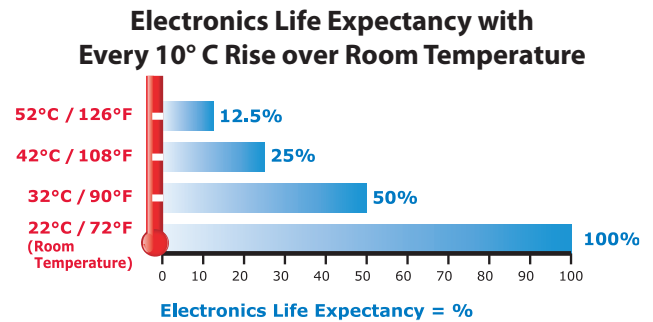

Sources of Heat

Damaging heat can come from a variety of sources. Inside the cabinet, heat can come from:

- AC power supplies
- Controllers, drives and servos
- Transformers and rectifiers
- Processors and server racks
- Radio equipment
- And other electronic components

Heat also comes from sources outside the enclosure such as:

- Solar heat gain
- Welding processes
- Paint oven
- Blast furnace
- Foundry equipment

Trend Toward More Damaging Heat

For the foreseeable future, the trend is toward increasing levels of heat in electronics, not less, because the market's thirst for more information processing capacity and speed continues to grow. This trend is known as "Moore's Law."

More powerful data-processing electronics generate extra heat with virtually every new system that is designed. There is no guarantee that an application which did not require much, if any, cooling in the past will not need cooling in the future. The new system likely has more functionality and will probably require some form of cooling as a result.

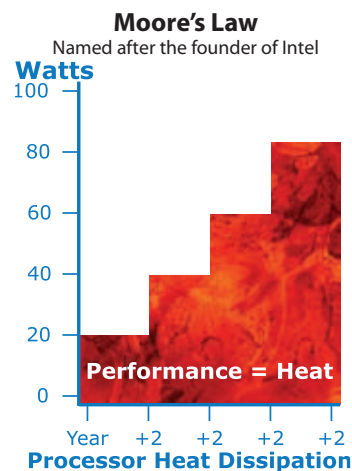

What Are the Consequences of Damaging Heat?

Heat build-up can adversely affect industrial controls and sensitive electronic systems as follows:

- De-rated drive performance
- I/C-based devices experience intermittent fluctuations
- MTBF decreases exponentially
- Catastrophic failure

The costs when a factory line or electronic system fails can include:

- Productivity losses
- Component replacement costs
- Late shipments
- Customer dissatisfaction
- Lost revenue
- Cell phone tower outage
- Breach in homeland security

Direct costs to a business can be as much as US \$50000 per hour of system downtime.

Conductive Cooling

This is a passive way to cool electronics. It simply allows the heat to radiate through the cabinet walls.

Conductive cooling works well with electronics systems that have small heat loads (<50 W) and cool air around the enclosure (<78 F/25 C).

If heat is an issue, one option within this type of cooling is to increase cabinet size to create more surface area to speed the transfer of heat. However, growing cabinet size is often not a practical solution because of space limitations and the greater heat loads associated with today's high-power electronics.

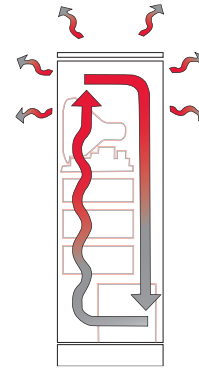

Fresh Air Cooling

This is an active way to manage heat in electronics applications. This type of cooling ventilates fresh air through the cabinet, exhausting heat away from the hot components.

Fresh air cooling may be used when the electronics system is deployed in a relatively clean and cool environment such as an office building, data networking center or light-duty factory. Options for cooling electronic enclosures with fresh air include filter fans, fan trays, motorized impellers and packaged blowers.

Fresh air cooling is known as an “open-loop system” because no significant seal is maintained to protect electronic components from harmful elements such as dirt, water, metal filings and corrosive fumes.

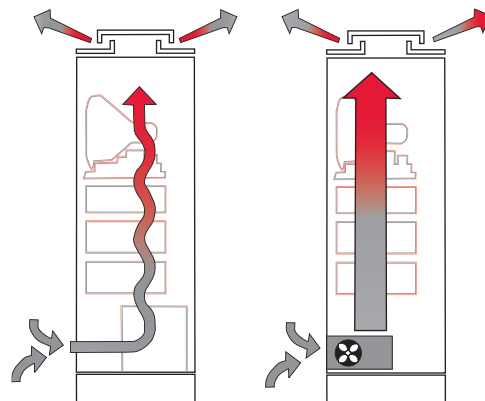

Protective Cooling

This is another active way to cool electrical components. This type of thermal management maintains the seal of the enclosure—using an air conditioner or heat exchanger as examples—to remove heat from inside the electronics cabinet.

Protective cooling is generally required when the electronics application:

- (1) operates in high temperatures, typically over 95 F/35 C,
- (2) is deployed in a harsh environment such as an outdoor telecom base station, wastewater treatment plant, metal working operation, oil rig platform, paper mill, foundry and/or
- (3) generates a high heat load from its own components, usually more than 500 W.

Options for protective cooling include air conditioners, air-to-air heat exchangers, air-to-water heat exchangers, thermo-electric coolers and vortex coolers.

Protective cooling is known as a “closed-loop system” because the seal of the electrical cabinet is maintained, allowing no elements which can damage the electronics inside the enclosure.

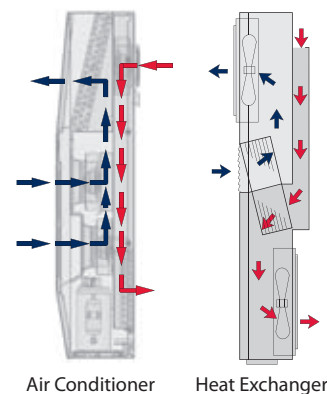

Protection Levels

NEMA, UL and CSA Ratings Enclosure Type Descriptions for Non-Hazardous Locations

	Type	NEMA	UL	CSA
Indoor	Type 1	Enclosures are intended for indoor use primarily to provide a degree of protection against contact with the enclosed equipment or locations where unusual service conditions do not exist.	Indoor use primarily to provide protection against contact with the enclosed equipment and against a limited amount of falling dirt.	General purpose enclosure. Protects against accidental contact with live parts.
Indoor	Type 12	Enclosures are intended for indoor use primarily to provide a degree of protection against dust, falling dirt and dripping noncorrosive liquids.	Indoor use to provide a degree of protection against dust, dirt, fiber flyings, dripping water and external condensation of noncorrosive liquids.	Indoor use; provides a degree of protection against circulating dust, lint, fibers and flyings; dripping and light splashing of non-corrosive liquids; not provided with knockouts.
Indoor	Type 12K	Enclosures with knockouts are intended for indoor use primarily to provide a degree of protection against dust, falling dirt and dripping noncorrosive liquids.	Indoor use to provide a degree of protection against dust, dirt, fiber flyings, dripping water and external condensation of noncorrosive liquids.	Indoor use; provides a degree of protection against circulating dust, lint, fibers and flyings; dripping and light splashing of noncorrosive liquids; not provided with knockouts.
Indoor	Type 13	Enclosures are intended for indoor use primarily to provide a degree of protection against dust, spraying of water, oil and noncorrosive coolant.	Indoor use to provide a degree of protection against lint, dust seepage, external condensation and spraying of water, oil and noncorrosive liquids.	Indoor use; provides a degree of protection against circulating dust, lint, fibers and flyings; seepage and spraying of non-corrosive liquids, including oils and coolants.
Outdoor	Type 3	Enclosures are intended for outdoor use primarily to provide a degree of protection against windblown dust, rain and sleet; undamaged by the formation of ice on the enclosure.	Outdoor use to provide a degree of protection against windblown dust and windblown rain; undamaged by the formation of ice on the enclosure.	Indoor or outdoor use; provides a degree of protection against rain, snow and windblown dust; undamaged by the external formation of ice on the enclosure.
Outdoor	Type 3R	Enclosures are intended for outdoor use primarily to provide a degree of protection against falling rain and sleet; undamaged by the formation of ice on the enclosure.	Outdoor use to provide a degree of protection against falling rain; undamaged by the formation of ice on the enclosure.	Indoor or outdoor use; provides a degree of protection against rain and snow; undamaged by the external formation of ice on the enclosure.
Outdoor	Type 3RX	Enclosures are intended for outdoor use primarily to provide a degree of protection against corrosion, falling rain and sleet; undamaged by the formation of ice on the enclosure.	Not specifically defined.	Not specifically defined.
Outdoor	Type 4	Enclosures are intended for indoor or outdoor use primarily to provide a degree of protection against windblown dust and rain, splashing water and hose directed water; undamaged by the formation of ice on the enclosure.	Either indoor or outdoor use to provide a degree of protection against falling rain, splashing water and hose-directed water; undamaged by the formation of ice on the enclosure.	Indoor or outdoor use; provides a degree of protection against rain, snow, windblown dust, splashing and hose-directed water; undamaged by the external formation of ice on the enclosure.
Outdoor	Type 4X	Enclosures are intended for indoor or outdoor use primarily to provide a degree of protection against corrosion, windblown dust and rain, splashing water and hose-directed water; undamaged by the formation of ice on the enclosure.	Either indoor or outdoor use to provide a degree of protection against falling rain, splashing water and hose-directed water; undamaged by the formation of ice on the enclosure; resists corrosion.	Indoor or outdoor use; provides a degree of protection against rain, snow, windblown dust, splashing and hose-directed water; undamaged by the external formation of ice on the enclosure; resists corrosion.
Outdoor	Type 6	Enclosures are intended for use indoors or outdoors where occasional submersion is encountered; limited depth; undamaged by the formation of ice on the enclosure.	Indoor or outdoor use to provide a degree of protection against entry of water during temporary submersion at a limited depth; undamaged by the external formation of ice on the enclosure.	Indoor or outdoor use; provides a degree of protection against the entry of water during temporary submersion at a limited depth. Undamaged by the external formation of ice on the enclosure; resists corrosion.

- This material is reproduced with permission from NEMA. The preceding descriptions, however, are not intended to be complete representations of National Electrical Manufacturers Association standards for enclosures nor those of the Electrical and Electronic Manufacturers Association of Canada.
- This material is reproduced with permission from Underwriters Laboratories Inc. Enclosures for Electrical Equipment, UL 50, 50E and Industrial Control Panels, UL 508A.
- This material is reproduced with permission from the Canadian Standards Association.
- Underwriters Laboratories Inc. (UL) shall not be responsible for the use of or reliance upon a UL Standard by anyone. UL shall not incur any obligation or liability for damages, including consequential damages, arising out of or in connection with the use, interpretation of, or reliance upon a UL Standard.
- Some enclosures may have multiple ratings. For instance: 4, 12—Outdoor use; able to be used indoors with modifications; 4X, 3RX—Outdoor use; able to be used indoors with modifications; 4, 9—Can be used in both hazardous and non-hazardous locations

IP Rating Descriptions **Example Rating**

If 1st IP number is...	and the 2nd IP number is...	Then the IP rating is
2 (protection against solid objects)	3 (protection against liquids)	IP23 An enclosure with this designation provides protection against touch with a finger, penetration of solid objects greater than 12 mm and spraying water.

First Numeral (Solid Objects and Dust)

IP	Protection of Persons	Protection of Equipment
0	No Protection	No Protection
1	Protected against contact with large areas of the body (back of hand)	Protected against objects over 50 mm in diameter
2	Protected against contact with fingers	Protected against solid objects over 12 mm in diameter
3	Protected against tools and wires over 2.5 mm in diameter	Protected against solid objects over 2.5 mm in diameter
4	Protected against tools and wires over 1 mm in diameter	Protected against solid objects over 1 mm in diameter
5	Protected against tools and wires over 1 mm in diameter	Protected against dust (limited ingress, no harmful deposit)
6	Protected against tools and wires over 1 mm in diameter	Totally protected against dust

Second Numeral (Liquid)

IP	Protection of Equipment
0	No Protection
1	Protected against vertically falling drops of water, e.g. condensation
2	Protected against direct sprays of water up to 15 degrees from vertical
3	Protected against sprays up to 60 degrees from vertical
4	Protected against water sprayed from all directions (limited ingress permitted)
5	Protected against low-pressure jets of water from all directions (limited ingress permitted)
6	Protected against strong jets of water
7	Protected against the effects of immersion between 15 cm and 1 m
8	Protected against long periods of immersion under pressure

SCCR Requirements per UL (Condensed version)

Article 409 of the 2008 National Electric Code (NFPA 70) requires industrial control panels to be marked with a short circuit current rating. As specified in the National Electric Code, UL508A-2001 Supplement SB, the Standard of Safety for Industrial Control Equipment, provides an accepted method for determining the short-circuit current rating of the control panel.

The Short Circuit Current Rating (SCCR) rating for our air conditioners and heat exchangers has a default value of 5 kA.

You may use a 5 or 10 kVA isolation transformer between the customer’s panel and our air conditioner and not have an effect on the customer’s 65 kA rating.

You may use a fuse or circuit breaker with a 5 kA short circuit rating on the line side of the air conditioner unit (ACU) and its branch circuit protective device and not have an effect on the customer’s 65 kA rating.

The current limiting fuse or circuit breaker used on the line side of the branch circuit protection for the ACU must have a SCCR => that of the panel rating. Additionally for a current limiting fuse the customer would need to verify using table SB4.2 of UL 508A, that the let through current ($I_p * 10^3$) of the fuse is ≤ 5 kA. If a circuit breaker is used as feeder protection, it **must** be marked Current Limiting type from the manufacturer, and the panel builder would need to verify based on the manufacturers published curves that it will let through ≤ 5 kA. Examples of these curves are included in UL 508A supplement SB.

You can run separate circuits for the panel and the air conditioner as long as each is labeled with their individual SCCR ratings (5 kA and 65 kA).

If the customer does not implement one of the options above, then the resulting SCCR rating would be the 5 kA rating of the ACU, if that is the lowest rated component in the panel.

Testing represents another option; however, if the customer does not implement these options, then the resulting short circuit rating of the panel is based on the lowest short circuit current rating of all power circuit components installed in the panel.

Cooling Solution

Since heat dissipation is often not a solution, we will limit our choices to protective vs. fresh air cooling.

Use the environmental and electronic system criteria in the table below to determine whether protective or fresh air cooling is most appropriate for your application.

Protective vs. Fresh Air Cooling

Specifying protective cooling that keeps your electronics components sealed from the outside environment versus using fresh air cooling to remove damaging heat depends on the following profile of your system application (check one side or the other for each of the six choices):

	FRESH		PROTECTIVE	
Clean Air / Some Dust / Dripping Water	<input type="checkbox"/>	SYSTEM OPERATING ENVIRONMENT	<input type="checkbox"/>	Dirty / Wet / Metal Filings / Outdoors / Corrosive Fumes
Moderate to Low (typically under 95 F / 35 C)	<input type="checkbox"/>	TEMPERATURE OUTSIDE OF THE ENCLOSURE	<input type="checkbox"/>	Hot (typically over 95 F / 35 C)
Somewhat to Well-Above Ambient Temperature	<input type="checkbox"/>	TEMPERATURE RATING OF THE ELECTRONICS	<input type="checkbox"/>	Below to Somewhat Above Ambient Temperature
Moderate to Low	<input type="checkbox"/>	HUMIDITY OUTSIDE OF THE ENCLOSURE	<input type="checkbox"/>	High Relative Humidity
Wide	<input type="checkbox"/>	TEMPERATURE RANGE FOR THE ELECTRONICS	<input type="checkbox"/>	Narrow / Precise
Moderate to Low (typically under 3000 Watts)	<input type="checkbox"/>	SYSTEM POWER DRAW / HEAT LOAD	<input type="checkbox"/>	Moderate to High (typically over 3000 Watts)

If most of your assessments fell on the fresh air side, then a filter fan, fan tray, motorized impeller or blower is probably the correct cooling solution for your application. However, if most of your assessments were on the protective side, then an air conditioner or heat exchanger found in the McLean Protective Cooling Catalog is likely the right cooling solution for your electronics system.

Cooling Solution Choices

Assuming that protective cooling is needed for the application, there are two basic choices—air conditioners or heat exchangers.

An air conditioner should be specified when:

- The temperature inside the enclosure must be maintained at or below the ambient temperature
- Humidity must be removed
- A moderate to high heat load is being produced by the electronic system

A heat exchanger can be used to transfer heat from inside the enclosure to the outside atmosphere when:

- The electronic components can operate at a temperature above the ambient air temperature
- Humidity is not a factor
- A low to moderate heat load is being produced by the electronic system

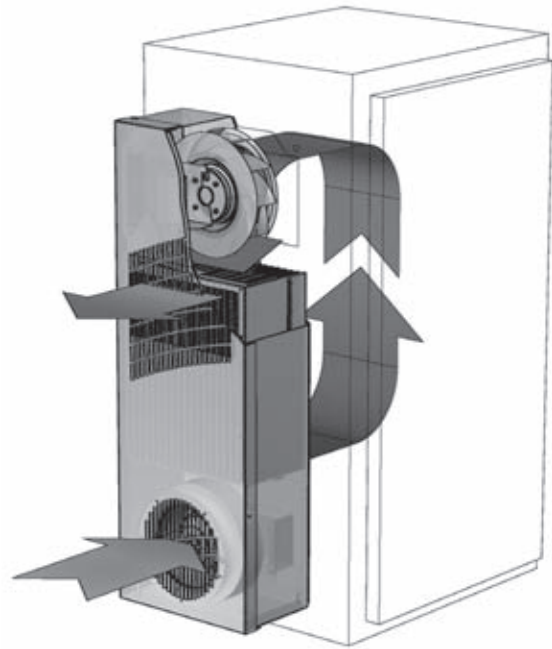
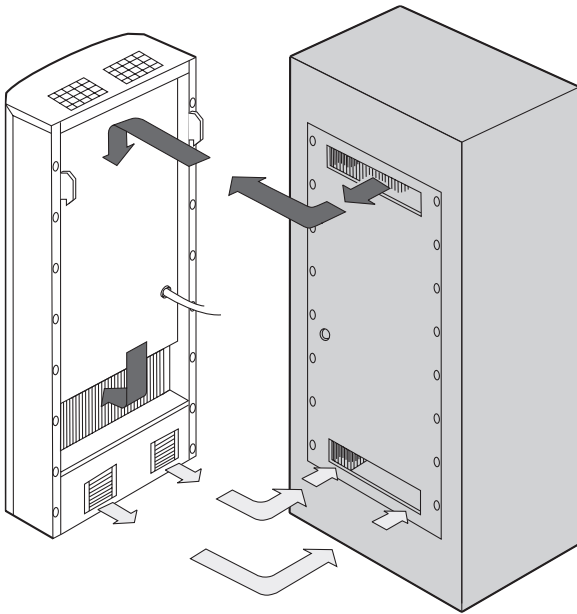

Air Conditioner Cooling Capacity Overview

The cooling capacity of an air conditioner needs to match or exceed the amount of total heat load generated by the electronic system.

Total heat load comes from two sources:

- (a) the electronic components themselves which is called "internal heat load" and
- (b) the ambient heat outside the enclosure which is known as the "heat transfer load."

Most engineers and cooling suppliers determine internal heat load. However, the impact from the heat transfer load is easily overlooked. Heat transfer load can significantly add to the total heat load of the system, especially if the outside air temperature is high and/or the enclosure is located in the sun.

Thus, the **total heat load** to be removed from the electrical enclosure by the air conditioner is the sum of the **internal heat load** and the **heat transfer load**.

$$\text{TOTAL HEAT LOAD} = \text{INTERNAL HEAT LOAD} + \text{HEAT TRANSFER LOAD}$$

Part A: How to Determine Internal Heat Load

The internal heat load comes from the amount of waste heat generated inside the enclosure by the electronic components and is expressed in Watts (W).

There are several methods to determine internal heat load, depending on data availability.

Method 1. Heat Load Data from Each Electronics Component Manufacturer

One way to estimate internal load is to gather heat load data from the manufacturers of the electronics components inside the cabinet. They may know the amount of heat their equipment is generating. If more than one control or other electronics components are inside the enclosure, it will be necessary to add together all the estimates of heat load to determine total internal heat load.

Method 2. Component Power – Component Efficiency

A second method is to establish the Watts of power used by each electronic component. Derive Watts of power by multiplying the amp draw of each device by its voltage. Then subtract the efficiency of each component from its estimated power use. Add up the outcomes to get the total internal heat load.

$$\text{INTERNAL HEAT LOAD} = \text{COMPONENT POWER (W)} - \text{COMPONENT EFFICIENCY (for each electrical device)}$$

Example—

An electronic system uses two components that draw 115 VAC at 15 A. Each has a rated efficiency of 90%. Put another way, 10% of each device is inefficient. Unused power becomes generated heat. Thus the estimated internal heat load is:

$$\begin{aligned} \text{Device Power} &= 115 \times 15 = 1725 \text{ W} \\ \text{Total Power} &= 2 \times 1725 = 3450 \text{ W} \\ \text{Less Efficiency} &= 3450 \times (1 - .90) \text{ W} \\ \text{Total Heat Load} &= 345 \text{ W} \end{aligned}$$

Method 3. Incoming – Outgoing Power

A third approach is to estimate the power going into the enclosure and the power coming out of it. The difference becomes the estimated amount of internal heat load. The amps and volts of each electrical line going in are multiplied to determine Watts, then they're added together. The same is done for the electrical line(s) coming out of the application. The outgoing Watts are then subtracted from the incoming Watts.

$$\text{INTERNAL HEAT LOAD} = \text{INCOMING POWER (W)} - \text{OUTGOING POWER (W)}$$

Example—

An enclosure has three input lines of 230 VAC at 11, 6 and 4 A. It has one output control line of 115 VAC at 9 A.

$$\begin{aligned} \text{Incoming Power} &= (230 \times 11) + (230 \times 6) + (230 \times 4) = 4830 \text{ W} \\ \text{Outgoing Power} &= 115 \times 9 = 1035 \text{ W} \\ \text{Total Heat Load} &= 4830 - 1035 = 3795 \text{ W} \end{aligned}$$

Method 4. Automated Equipment Horsepower

This fourth method applies only to industrial automation equipment that operates with horsepower (hp) such as variable frequency drives (VFDs). 1 hp = 745.6 W. Thus, the internal heat load from a 3-hp VFD is 2237 W, less its efficiency which is typically 93% - 95%.

Example—

A cabinet has three 5-hp VFDs with 95% efficiency.

$$\begin{aligned} \text{VFD Watts} &= 5 \text{ hp} \times 745.6 \times 3 = 11184 \text{ W} \\ \text{Adjusted Watts} &= 11184 \times (1 - .95) = 559 \text{ W} \\ \text{Total Heat Load} &= 559 \times 1.25 = 699 \text{ W} \end{aligned}$$

1.25 is an assumed "safety" margin for other minor heat-producing components.

Part B: How to Determine Heat Transfer Load Overview

Heat transfer load is the ambient heat outside the enclosure conducting itself through the cabinet walls toward the electronics (heat energy travels from the hottest to coldest location).

When an air conditioner cools the enclosure temperature lower than the ambient air outside, additional heat load is drawn into the cabinet which the air conditioner needs to remove. The higher the ambient temperature and/or the presence of solar heat gain (the “greenhouse effect”) on the enclosure, the more cooling capacity is required.

Determining heat transfer load requires that you know the **total surface area** of the cabinet, less any non-conductive surface area such as the enclosure side mounted to a wall. It also requires that you determine ΔT , which is the difference between maximum ambient temperature and the maximum temperature rating of the electronics components.

There are two methods for determining heat transfer load—the simple chart method and the equation method.

Simple Chart Method

This method is reasonably accurate for most indoor industrial systems where there is no unusual air movement and insulation is not typically used inside the enclosure. The process also provides a ballpark result for outside plant and telecommunications applications, taking into account solar heat gain. However, it does not incorporate the impact of wind or cabinet insulation. If either is present, then the equation method is more precise.

- Step 1. Determine ΔT in F or C.
- Step 2. Find the heat transfer per ft.² or m² on the chart below, using ΔT and the proper cabinet material curve.
- Step 3. Multiply the heat transfer per ft.² or m² by the total surface area of the enclosure that will conduct heat. (Remember to exclude surfaces such as a side mounted to a wall.)

$SURFACE\ AREA\ (ft.^2) = [2ab\ (in.) + 2bc\ (in.) + 2ac\ (in.)] \div 144$

$SURFACE\ AREA\ (m^2) = [2ab\ (mm) + 2bc\ (mm) + 2ac\ (mm)] \div 1000000$
 Caption: a = height, b = width, c = depth

Total Heat Transfer Load =
 Heat Transfer per ft.² or m² x Cabinet Surface Area

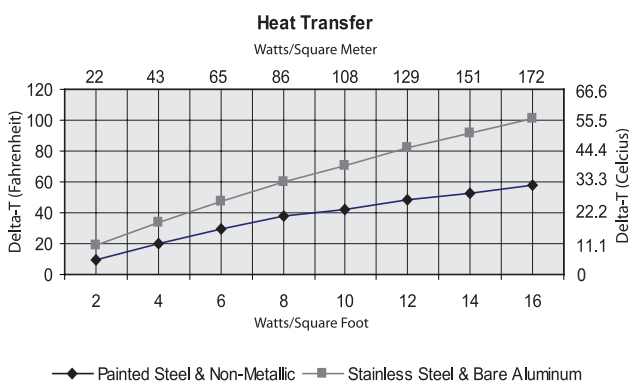

Example —

A painted steel cabinet has 7.43 m² of surface area and will be located in a maximum ambient temperature of 35 C. The rated temperature of the electronics is 24 C.

$\Delta T = 35\ C - 24\ C = 11\ C$
 Heat Transfer = 43 W/m² (from chart)

Total Heat Transfer Load = 7.43 x 43 = 320 W

The estimate for heat transfer load ends here, unless the electronic system will be deployed outdoors. Then solar heat gain needs to be added to the total heat transfer load calculated above. Solar heat gain is determined much the same way as heat transfer per ft.² or m², using a similar chart.

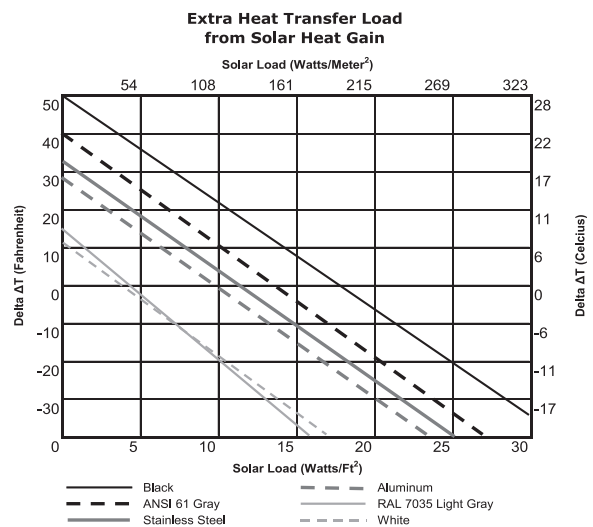

Example — The painted cabinet above is in ANSI 61 gray. Thus, 75.4 W/m² need to be added to the heat transfer load which is 560 W (75.4 x 7.43). Total Heat Transfer Load consequently becomes 720 W.

The result does not include insulation which can significantly reduce heat transfer load.

Equation Method

Heat transfer load may also be determined by equation. This method should be used when at least one of the following criteria are found in the electronic system:

- Moderate to high airflow within the cabinet
- Outdoor applications that involve breezes or gusty winds
- Insulation used within the cabinet to offset the impact of solar heat gain

The governing equations for heat transfer load are:

English System (F, inches and feet):

$$q = (T_o - T_i) \div [(1/h_o) + (1/h_i) + R]$$

Metric System (C, millimeters and meters):

$$q = (T_o - T_i) \div [(1/h_o) + (1/h_i) + R] \times 5.67$$

$$q = (125 - 75) \div [(1/6) + (1/2) + 4]$$

$$q = (50) \div (.16 + .5 + 4)$$

$$q = 50 \div 4.66$$

$$q = 10.7 \text{ BTU/Hr./ft.}^2$$

Total Heat Transfer Load

$$10.7 \times 72 = 770 \text{ BTU/Hr. or } 770 \div 3.413 = 226 \text{ W}$$

Since the cabinet is outdoors, and assuming it is painted ANSI 61 gray and located in the sun, extra solar load needs to be added to the outcome above which is 504 W (7 W per ft.² x 72 ft.²).

Total Heat Transfer Load with Extra from Solar Heat Gain

$$226 + 504 = 730 \text{ W}$$

Definition of Variables—

q = Heat transfer load per unit of surface area

T_o = Maximum ambient temperature outside the enclosure

T_i = Maximum rated temperature of the electronics components

h_o = Convective heat transfer coefficient outside the cabinet

Still air: h = 1.6

Relatively calm day: h = 2.5

Windy day (approx. 24 km/h): h = 6.0

h_i = Convective heat transfer coefficient inside the cabinet

Still air: h = 1.6

Moderate air movement: h = 2.0

Blower (approx. 2.44 m/s): h = 3.0

R = Value of insulation lining the interior of the enclosure walls

No insulation: R = 0.0

1/2 in. or 12 mm: R = 2.0

1 in. or 25 mm: R = 4.0

1-1/2 in. or 38 mm: R = 6.0

2 in. or 51 mm: R = 8.0

1 in. = 25.4 mm

1 ft. = 0.3048 m

1000 BTU/Hr. = 293.06 W

1 mph = 1.6093 km/h

How to Determine Total Heat Load

Total heat load to be removed from the electrical enclosure by the air conditioner is the sum of **internal heat load** plus **heat transfer load**.

$$\text{TOTAL HEAT LOAD (C)} = \text{INTERNAL HEAT LOAD (A)} + \text{HEAT TRANSFER LOAD (B)}$$

Thus, one adds together the result from Part A to the outcome from Part B.

Example—

The internal heat load from one of the examples above was 3795 W. The heat transfer load from the other example above was 730 W. Therefore, total heat load is 3795 + 730 = 4525 W.

To convert Watts into BTU/Hr. to determine air conditioner capacity in the English system, multiply by 3.413. 4525 W is then 15444 BTU/Hr.

Power input, protection level and dimensions of the air conditioner also need to fit system requirements.

Caution! Do not simply match the nominal cooling capacity of the air conditioner model with the total heat load result above. Be sure to know the maximum ambient temperature outside the enclosure as well as the rated temperature of the electronic components. Apply these temperatures to the performance curves provided by the cooling manufacturer to select an appropriately sized air conditioner. Failure to do so may under-size your air conditioner as much as 20% - 25%, thereby under-cooling the electronics and making the application vulnerable to potential over-heating issues.

Heat Exchanger Cooling Capacity Overview

Cooling with an air-to-air heat exchanger assumes the electronic components in your system are able to operate **above** the ambient temperature outside the enclosure. If this is not the case, then an air conditioner must be used.

Selecting a heat exchanger is similar to specifying an air conditioner in that the cooling capacity of the unit must remove the **internal heat load** from the electrical enclosure.

However, since the conductive cooling nature of the cabinet itself removes some of the heat from the system, **heat transfer** should be subtracted from internal heat load (versus added in the case of air conditioners).

Because the cooling capacity of heat exchangers is expressed in terms of Watts/F or Watts/C, an extra step is necessary to convert net heat load into a result used to select the appropriate heat exchanger. Divide the net heat load by the ΔT which is the difference between the maximum ambient temperature outside the enclosure and the maximum temperature rating of the electronic components.

$$\text{HEAT EXCHANGER CAPACITY (C)} = [\text{INTERNAL HEAT LOAD (A)} - \text{HEAT TRANSFER (B)}] / \Delta T$$

How to Determine Internal Heat Load

Internal heat load stems from the amount of waste heat generated inside the enclosure by the electronic components and is expressed in Watts.

To determine internal heat load, follow one of the four options outlined in the air conditioner “How to Determine Internal Heat Load” section on page 12.

How to Determine Heat Transfer

In air-to-air heat exchangers, heat transfer is actually cabinet heat loss because the heat inside the enclosure is conducting itself through the cabinet walls toward the cooler temperature outside the enclosure. That is why heat transfer is subtracted from internal heat load to arrive at total net heat load.

To determine heat transfer you need to know the **total surface area** of the cabinet, less any non-conductive surface area such as the enclosure side mounted to a wall. You must also determine ΔT which is the difference between maximum ambient temperature and the maximum temperature rating of the electronic components.

There are two methods to determine heat transfer—the **simple chart method** and the **equation method**. The simple chart method may be used for nearly all indoor heat exchanger applications. The equation method needs to be applied when air movement outside or inside the electrical enclosure is high, or for outdoor applications.

Here are the steps for the simple chart method:

Step 1. Determine ΔT in F or C.

Step 2. Find the heat transfer per ft.² or m² from the Heat Transfer graph on page 13, using ΔT and the proper cabinet material curve.

Step 3. Multiply the heat transfer per ft.² or m² by the total surface area of the enclosure that will conduct heat. (Remember to exclude surfaces such as a side mounted to a wall.)

$$\text{SURFACE AREA (ft.²)} = [2ab \text{ (in.)} + 2bc \text{ (in.)} + 2ac \text{ (in.)}] \div 144$$

$$\text{SURFACE AREA (m²)} = [2ab \text{ (mm)} + 2bc \text{ (mm)} + 2ac \text{ (mm)}] \div 1000000$$

Caption: a = height, b = width, c = depth

$$\text{Heat Transfer (Cabinet Heat Loss)} = \text{Heat Transfer per ft.² or m² x Enclosure Surface Area}$$

The estimate for heat transfer ends here, unless the electronic system will be deployed outdoors, or airflow inside or outside the enclosure is high. Then the equation method needs to be used to determine heat transfer (cabinet heat loss).

For the equation method, follow the steps on page 13 in the air conditioner selection section. The result will be a negative number; the negative sign should be ignored when deducting heat transfer from internal heat load.

Caution! If the result of the equation method is a positive number, then this means that you want the electronics temperature inside the cabinet to be lower than the temperature outside the enclosure. In this case, an air conditioner should be specified for the electronics system.

How to Determine Heat Exchanger Capacity

Air-to-air heat exchanger capacities are not provided in terms of Watts or BTUs/Hr. of cooling like air conditioners. Instead, they are expressed in terms of Watts/F or Watts/C. Thus, the final step in determining heat exchanger capacity is to divide the total net heat load by ΔT . Then select the heat exchanger with the same or higher Watts/F or Watts/C as the outcome of this process.

—Indoor Industrial Example—

An electronic system uses two components that draw 230 VAC at 7.5 A. Each has a rated efficiency of 90%. They are protected in a painted steel cabinet that is 60 in. (1524 mm) tall, 36 in. (914 mm) wide and 18 in. (457 mm) deep. The system will be located in a maximum ambient temperature of 80 F (27 C). The rated temperature of the electronics is 95 F (35 C).

$$\text{HEAT EXCHANGER CAPACITY (C)} = \frac{[\text{INTERNAL HEAT LOAD (A)} - \text{HEAT TRANSFER (B)}]}{\Delta T}$$

Internal heat load (A) may be determined using the “Component Power – Component Efficiency” method on page 12, given the available information. In this example, the estimated heat load is:

$$\begin{aligned} \text{Device Power} &= 230 \times 7.5 = 1725 \text{ W} \\ \text{Total Power} &= 2 \times 1725 = 3450 \text{ W} \\ \text{Less Efficiency} &= 3450 \times (1 - .90) \text{ W} \\ \text{Internal Heat Load} &= 345 \text{ W} \end{aligned}$$

Heat transfer (B) is derived using the simple chart method, since this is an indoor industrial application. Both cabinet surface area and ΔT are needed to determine heat transfer. Cabinet surface area is 54 ft.² or 5.02 m² (from surface area formula on page 13). ΔT is 15 F (8 C)—the difference between ambient temperature and the rated temperature of the electronics.

$$\begin{aligned} \text{Heat Transfer (Cabinet Heat Loss)} &= \\ \text{Heat Transfer per ft.}^2 \text{ or m}^2 \times \text{Enclosure Surface Area} \end{aligned}$$

Using the painted steel curve on the Heat Transfer chart on page 13, heat transfer per ft.² or m² is 3 W/ft.² or 32.5 W/m².
 Heat Transfer = 3 W/ft.² x 54 ft.² = 162 W

Now that we know internal heat load, heat transfer and ΔT , we can determine heat exchanger capacity as follows:

$$\text{HEAT EXCHANGER CAPACITY (C)} = \frac{[345 \text{ W (A)} - 162 \text{ W (B)}]}{15 \text{ F (or 8 C)}}$$

$$\text{HEAT EXCHANGER CAPACITY (C)} = 12 \text{ W/F or } 22 \text{ W/C}$$

The result is **minimum** heat exchanger capacity. If no heat exchanger model is similar to the result, choose the next largest size to ensure adequate electronics cooling.

Power input, protection level and dimensions of the heat exchanger also need to fit the system.

—Outdoor Example—

A telecom system draws a total of 5000 W; its efficiency is 85%. It is protected in a steel cabinet that is 72 ft.² (6.69 m²) and painted with ANSI 61 gray paint. The enclosure walls are lined inside with 1 in. (25 mm) of insulation. The application will be deployed in a maximum ambient outdoor temperature of 104 F (40 C) with occasional winds reaching 24 km/h. The rated temperature of the electronics is 114 F (46 C). Air circulation inside the cabinet is moderate.

$$\text{HEAT EXCHANGER CAPACITY (C)} = \frac{[\text{INTERNAL HEAT LOAD (A)} - \text{HEAT TRANSFER (B)}]}{\Delta T}$$

Internal heat load (A) is determined using the “Component Power – Component Efficiency” method on page 12. In this example, the estimated heat load is as follows:

$$\begin{aligned} \text{Total System Power} &= 5000 \text{ W} \\ \text{Less Efficiency} &= 5000 \times (1 - .85) \text{ W} \\ \text{Internal Heat Load} &= 750 \text{ W} \end{aligned}$$

Heat transfer (B) is derived using the equation method, since this is an outdoor application.

$$q = (T_o - T_i) \div [(1/h_o) + (1/h_i) + R]$$

“q” is heat transfer per surface area. For an explanation of the other variables, see “Equation Method” on page 14.

Example for metric system:

$$\begin{aligned} T_o &= 40 \text{ C} \\ T_i &= 46 \text{ C} \\ h_o &= 6 \\ h_i &= 2 \\ R &= 4 \\ \text{Surface area} &= 6.69 \text{ m}^2 \end{aligned}$$

$$q = (104 - 114) \div [(1/6) + (1/2) + 4]$$

$$q = -23 \text{ W/m}^2$$

$$\begin{aligned} \text{Total Heat Transfer} &= 23 \times 6.69 \text{ m}^2 = 154 \text{ W} \\ \text{(negative sign is ignored)} \end{aligned}$$

ΔT is 10 F — the difference between ambient temperature and the rated temperature of the electronics.

$$\text{HEAT EXCHANGER CAPACITY (C)} = \frac{[750 \text{ W (A)} - 154 \text{ W (B)}]}{[50/9] \text{ C}}$$

$$\text{HEAT EXCHANGER CAPACITY (C)} = 107 \text{ W/K}$$

As in the indoor industrial example, the above result is **minimum** heat exchanger capacity. If no heat exchanger model is similar to the result, choose the next largest size to ensure adequate electronics cooling.

Power input, protection level and dimensions of the heat exchanger also need to fit the system.

Notes

SPECTRACOOL™ **Indoor & Outdoor Air Conditioners**



G28 Indoor Model



G52 Indoor Model



G57 Outdoor Model

*Makes electronics cooling easier,
so you can go about your business*



SPECTRACOOL™ Indoor/Outdoor Air Conditioners

PRODUCT OVERVIEW

An energy-efficient rotary compressor and new earth-friendly refrigerant provide reliable cooling in rugged outdoor environments. All models are built with corrosion-resistant components and are Telcordia GR-487 capable.

APPLICATIONS

- Industrial automation
- Telecommunications equipment
- Wastewater treatment systems
- Package handling equipment
- Security and defense systems

SPECTRACOOL Chapter Contents

G28 Indoor/Outdoor Base Models	20
G28 Models 4000/6000 BTU	21
G52 Indoor/Outdoor Base Models	26
G52 8000/12000 BTU	27
G57 Indoor/Outdoor Base Models	34
G57 Models 20000 BTU.....	35

G28 Indoor/Outdoor Base Models



SPECTRACOOL A/C

Industry Standards

UL/cUL Listed Type 12, 3R, 4; 4X optional

CE
IP 56 Internal Loop
IP 34 on External Loop
Telcordia GR-487 capable (Outdoor)

Application

- Industrial automation
- Telecommunications equipment
- Waste water treatment systems
- Package handling equipment
- Security and defense systems
- And more

Features

- Energy efficient rotary compressor
- R407c and R134a earth-friendly refrigerants and RoHS compliant
- Models for 115, 230 and 400/460 3-phase AC volt power input
- UL Listed to save customers time and money with agency approvals
- Outdoor model operating temperature range from -40 F/-40 C to 131 F/55 C
- Exterior and partial recessed mounting options
- Attractive industrial design with minimal use of visible fasteners
- Reliable mechanical thermostat on enclosure side of the unit. Indoor Air Conditioner models include digital display on ambient side.
- Galvanized sheet-metal cover for rugged factory and outdoor environments
- Easy-mount flanges for simple installation

- Cut-out adapter options for enclosures with McLean GENESIS® and T-Series air conditioners, enabling users to easily transition to the new unit
- Dust-resistant condenser coil allows the unit to be run filterless in most applications
- Cleanable, reusable aluminum mesh filter to protect coils for maximum cooling performance
- Mounting hardware, gaskets and user manual furnished with the unit
- Every unit functionally tested before shipping
- Standard Indoor Air Conditioner models also include:
 - Active condensate management with heater strip
 - Power-off relay for door switch and other system requirements
 - Malfunction switch
- Standard Outdoor Air Conditioner models also include:
 - Telcordia GR-487 capable
 - Corrosion-resistant components
 - Malfunction switch
 - Compressor heater
 - Head pressure control
 - 2000 W enclosure heater

Specifications

- Nominal cooling capacity 4000 & 6000 BTUs/Hr. (1172 and 1758 W)
- Outdoor model operating temperature range from -40 F/-40 C to 131 F/55 C

Finish

- RAL 7035 light-gray, semi-textured powder-coat paint
- Other colors and textures available

Notes

Visit www.McLeanCoolingTech.com to download 2D and 3D CAD drawings into the overall design of your electronic system.

SPECTRACOOOL™

Technical Data **G28 Models 4000/6000 BTU/Hr. (1172/1758 W)**

CATALOG NUMBER						
Indoor Model	G280416G050	G280426G050	G280446G050	G280616G050	G280626G050	G280646G050
Indoor Model Stainless Steel Type 4X	G280416G051	G280426G051	G280446G051	G280616G051	G280626G051	G280646G051
Outdoor Model without Heat Pkg.	G280416G100	G280426G100	G280446G100	G280616G100	G280626G100	G280646G100
Outdoor Model Partial Recessed Mount	G280416G101	G280426G101	G280446G101	G280616G101	G280626G101	G280646G101
Outdoor Model without Heat Pkg. Stainless Steel Type 4X	G280416G102	G280426G102	G280446G102	G280616G102	G280626G102	G280646G102
Outdoor Model with Heat Pkg.	G280416G150	G280426G150		G280616G150	G280626G150	
Outdoor Model with Heat Pkg. Stainless Steel Type 4X	G280416G151	G280426G151		G280616G151	G280626G151	
COOLING PERFORMANCE						
Nominal:						
BTUs/Hr.	4600/4900	4600/4900	4600/4900	6000/6400	6000/6400	5400/6000
Watts	1347/1435	1347/1435	1347/1435	1757/1874	1757/1874	1581/1757
At 131 F/131 F (55 C/55 C):						
BTUs/Hr. (50/60 Hz)	4600/4900	4600/4900	4600/4900	6000/6400	6000/6400	5400/6000
W (50/60 Hz)	1347/1435	1347/1435	1347/1435	1757/1874	1757/1874	1581/1757
At 95 F/95 F (35 C/35 C):						
BTUs/Hr. (50/60 Hz)	4300/4600	4300/4600	4324/4655	5600/6000	5600/6000	5054/5685
W (50/60 Hz)	1260/1436	1260/1436	1267/1364	1641/1758	1641/1758	1481/1666
Refrigerant	R407C	R407C	R134A	R407C	R407C	R134A
Refrigerant Charge (ounces/grams)	20	20	16	20	20	16
Operating Temperature Range:						
Maximum (°F/°C)	131 F/55 C	131 F/55 C	131 F/55 C	131 F/55 C	131 F/55 C	131 F/55 C
Minimum (°F/°C)	-40 F/-40 C	-40 F/-40 C	-40 F/-40 C	-40 F/-40 C	-40 F/-40 C	-40 F/-40 C
Air Flow at 0 Static Pressure:						
Internal loop 50 Hz (CFM / m ³ /hr.)	189/321	189/321	189/321	189/321	189/321	189/321
External loop 50 Hz (CFM / m ³ /hr.)	291/494	291/494	291/494	291/494	291/494	291/494
Internal loop 60 Hz (CFM / m ³ /hr.)	221/375	221/375	221/375	221/375	221/375	221/375
External loop 60 Hz (CFM / m ³ /hr.)	300/509	300/509	300/509	300/509	300/509	300/509
Max. Heater W (Outdoor Models)	2000	2000		2000	2000	
ELECTRICAL DATA						
Rated Voltage	115	230	460 3~	115	230	460 3~
Frequency (Hz)	50/60	50/60	50/60	50/60	50/60	50/60
Operating Range	+/- 10%	+/- 10%	+/- 10%	+/- 10%	+/- 10%	+/- 10%
Max. Power Consumption (W at 50/60 Hz)	1138.5/1311	1058/1334	598/644	1138.5/1311	1058/1334	598/644
Max. Nominal Current (A at 50/60 Hz)	9.9/11.4	4.6/5.8	1.3/1.4	9.9/11.4	4.6/5.8	1.3/1.4
Starting Current (A)	36.2	17.7	7.7	36.2	17.7	7.7
Agency Approvals	cUL Listed CE	cUL Listed CE	cUL Listed CE	cUL Listed CE	cUL Listed CE	cUL Listed CE
Power Input Description	10-ft. cord with IEC connection at unit and NEMA 5-15 plug	10-ft. cord with IEC connection at unit and NEMA 6-15 plug	Terminal Block	10-ft. cord with IEC connection at unit and NEMA 5-15 plug	10-ft. cord with IEC connection at unit and NEMA 6-15 plug	Terminal Block
ENCLOSURE PROTECTION						
UL Type	Type 12/3R/4 Standard 4X Stainless Steel Optional					
CONTROLLER						
Description	Basic Mechanical Thermostat					
Thermostat Location	Enclosure Side on All Base Models					
Factory Thermostat Setting (°F/°C)	80/27	80/27	80/27	80/27	80/27	80/27
SOUND LEVEL						
At 1.5 M	68					
UNIT CONSTRUCTION						
Material	Galvanized Sheet Metal Standard (Optional: Stainless Steel)					
Finish	Powder Coat RAL 7035 Light Gray Standard					
UNIT DIMENSIONS						
Height (in./mm)	28.55/725.1	28.55/725.1	28.55/725.1	28.55/725.1	28.55/725.1	28.55/725.1
Width (in./mm)	16.97/431.1	16.97/431.1	16.97/431.1	16.97/431.1	16.97/431.1	16.97/431.1
Depth (in./mm)	10.10/256.6	10.10/256.6	10.10/256.6	10.10/256.6	10.10/256.6	10.10/256.6
Weight (lb./kg)	84/38	84/38	84/38	84/38	84/38	84/38
ACCESSORIES						
Indoor Cutout Adapter	Enables SPECTRACOOOL to be mounted to GENESIS M28 Air Conditioner Cutout Part #28621601					
Outdoor Cutout Adapter	Enables SPECTRACOOOL to be mounted to T-Series T29 Air Conditioner Cutout Part #28621603					

SPECTRACOOOL A/C

Performance Curves for G28 Models 4000 BTU/Hr. (1347/1435 Watt)

G28-04(1/2)6-GXXX- Capacity Curves at 50Hz; Without Filter

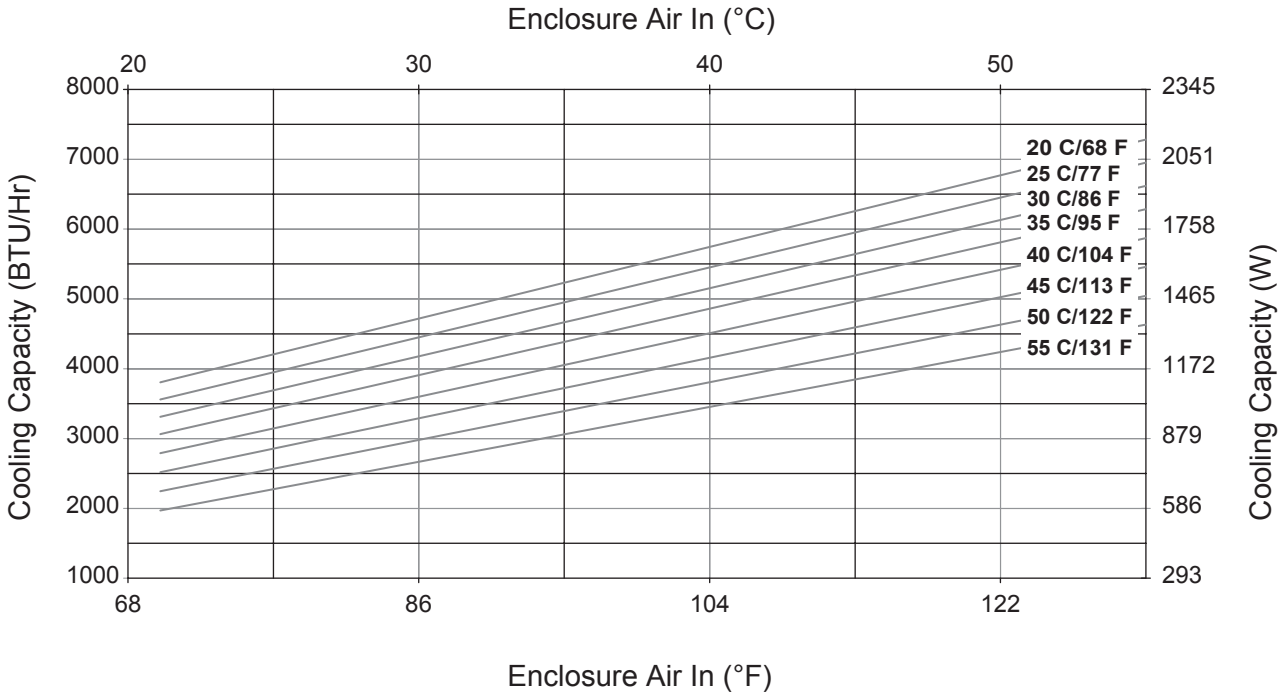

G28-04(1/2)6-GXXX- Capacity Curves at 60Hz; Without Filter

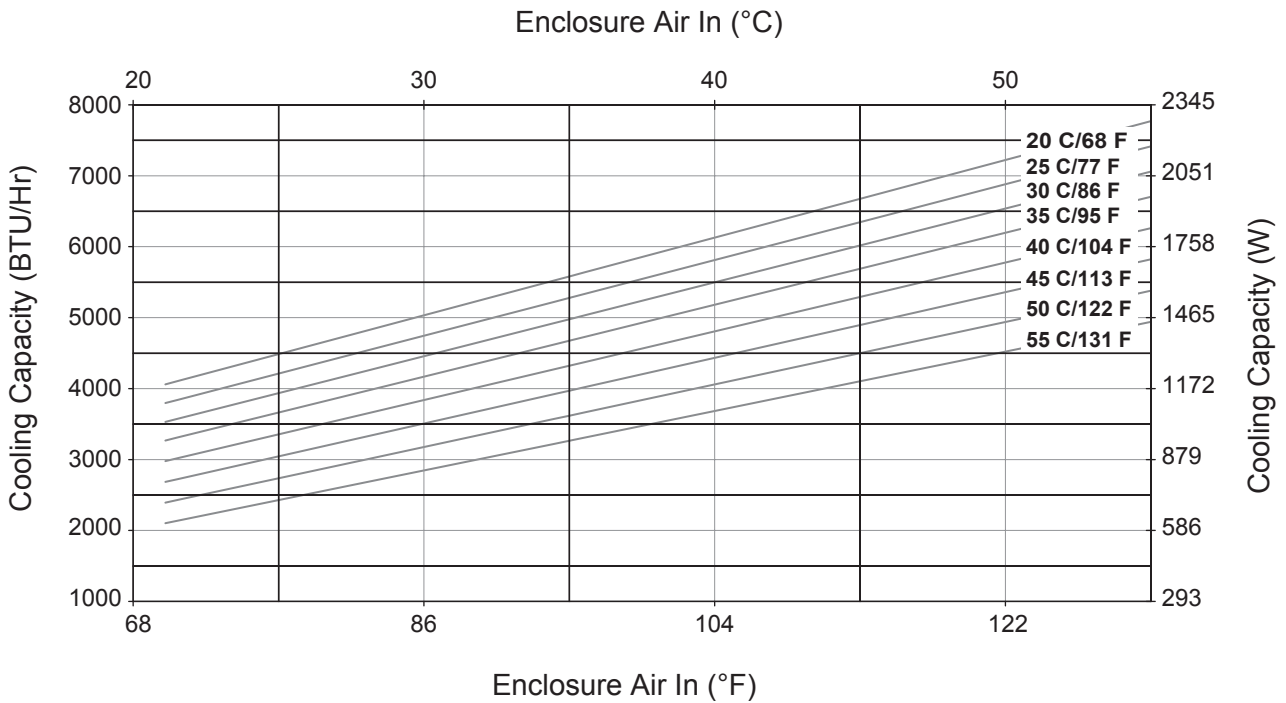

SPECTRACOOL A/C

Performance Curves for G28 Models 6000 BTU/Hr. (1758 Watt)

G28-0646-GXXX Performance Curve 400VAC/50Hz Without Air Filter

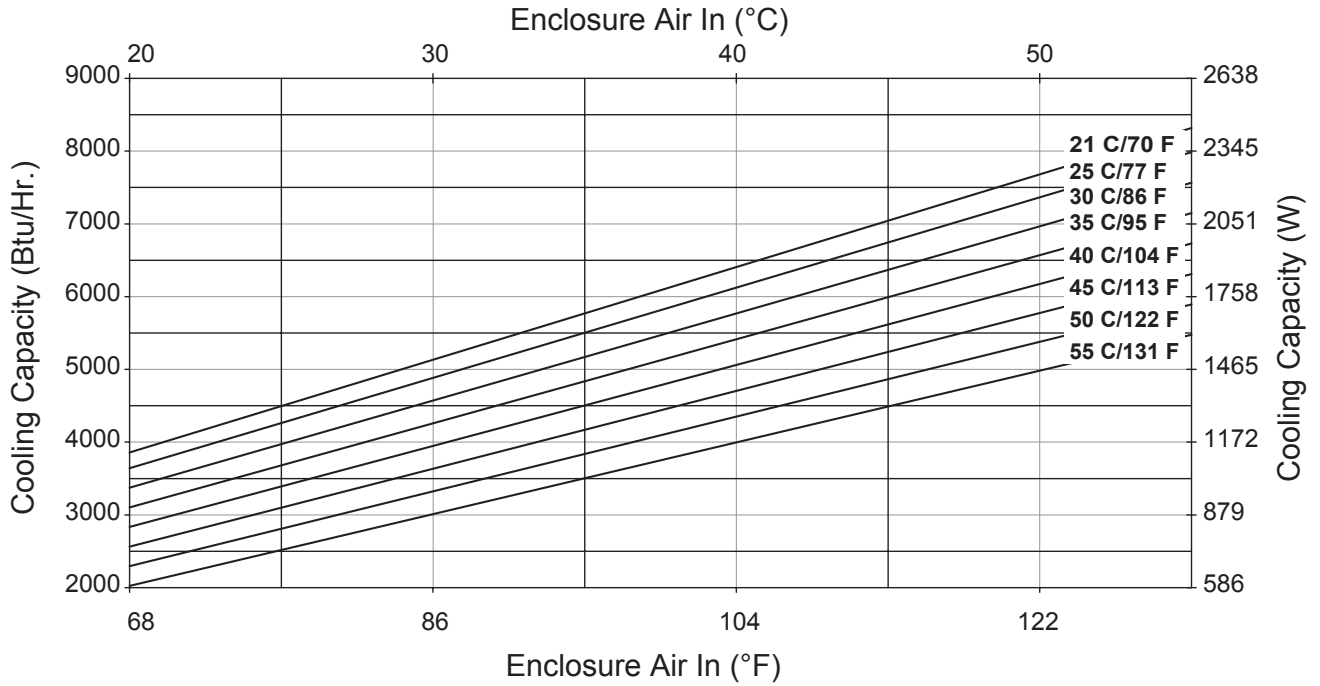

G28-0646-GXXX Performance Curve 460VAC/60Hz Without Air Filter

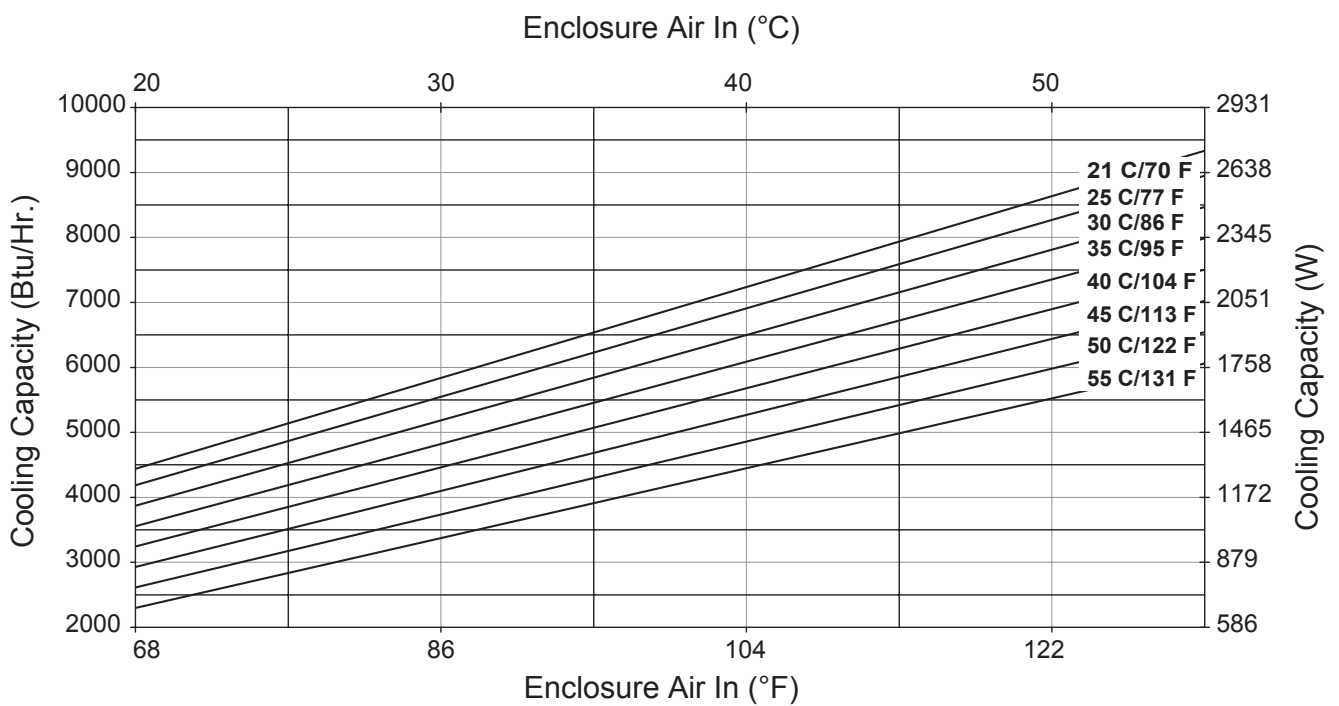

SPECTRACOOOL A/C

G28 Models 4000/6000 BTU/Hr. (1172/1757 Watt)

SPECTRACOOL A/C

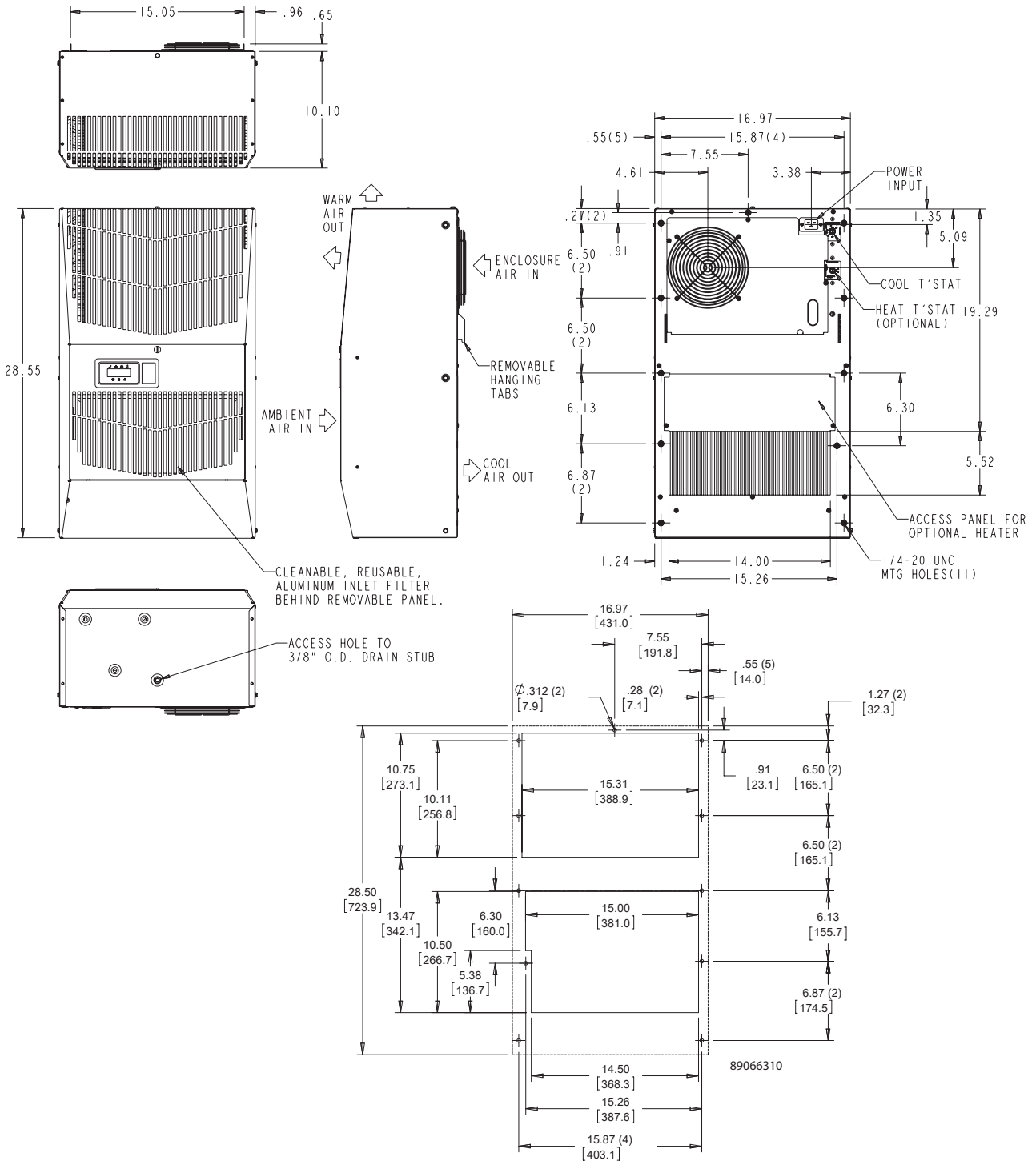

CUTOUT INSTRUCTIONS

G28 Models 4000/6000 BTU/Hr. (1172/1758 Watt) With Partial Recess

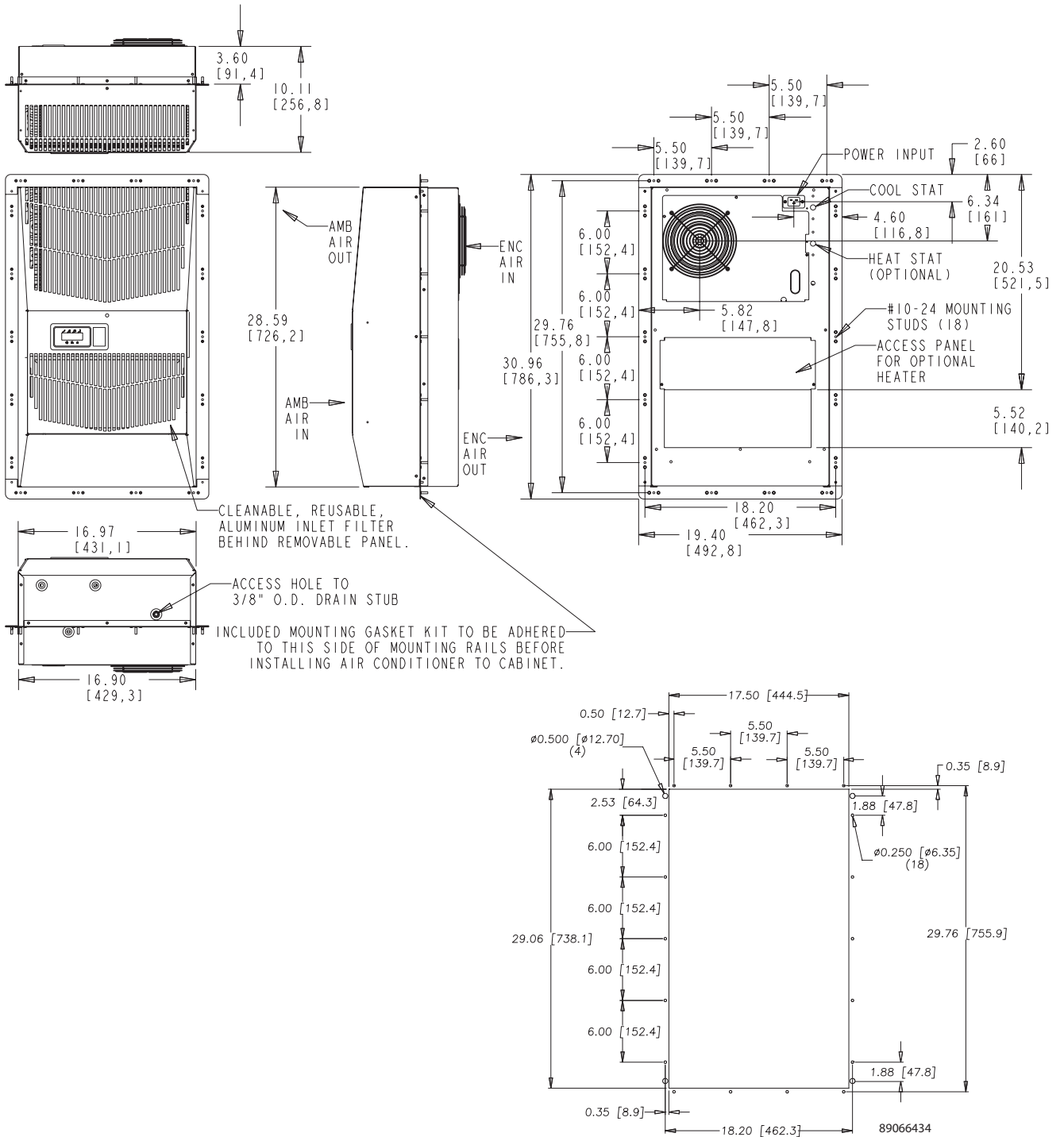

CUTOUT INSTRUCTIONS

Visit www.McLeanCoolingTech.com to download 2D and 3D CAD drawings into the overall design of your electronic system.

G52 Indoor/Outdoor Base Models

SPECTRACOOL A/C



G52 Indoor Model
8000 BTU/Hr.
2300 Watts



G52 Outdoor Model
12000 BTU/Hr.
3500 Watts

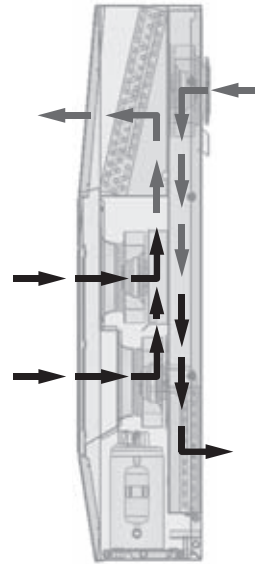

Industry Standards

UL/cUL Listed Type 12, 3R, 4; 4X optional

CE
IP 56 Internal Loop
IP 34 on External Loop
Telcordia GR-487 capable (Outdoor)

Application

- Industrial automation
- Telecommunications equipment
- Waste water treatment systems
- Package handling equipment
- Security and defense systems
- And more

Features

- Energy efficient rotary compressor
- R134a earth-friendly refrigerant and RoHS compliant
- Models for 115, 230 and 400/460 3-phase AC volt power input
- UL Listed to save customers time and money with agency approvals
- Outdoor model operating temperature range from -40 F/-40 C to 131 F/55 C
- Exterior and partial recessed mounting options
- Attractive industrial design with minimal use of visible fasteners
- Reliable mechanical thermostat on enclosure side of the unit. Indoor Air Conditioner models include digital display on ambient side.
- Dual condenser-side air movers for performance redundancy
- Galvanized sheet-metal cover for rugged factory and outdoor environments
- Easy-mount flanges for simple installation

- Cut-out adapter options for enclosures with McLean GENESIS® and T-Series air conditioners, enabling users to easily transition to the new unit
- Cleanable, reusable aluminum mesh filter to protect coils for maximum cooling performance
- Mounting hardware, gaskets and user manual furnished with the unit
- Every unit functionally tested before shipping
- Standard Indoor Air Conditioner models also include:
 - Active condensate management with heater strip
 - Power-off relay for door switch and other system requirements
 - Malfunction switch
- Standard Outdoor Air Conditioner models also include:
 - Telcordia GR-487 capable
 - Corrosion-resistant components
 - Malfunction switch
 - Compressor heater
 - Head pressure control
 - 2000 W enclosure heater

Specifications

- Nominal cooling capacity 8000 & 12000 BTUs/Hr. (2344 and 3516 W)
- R134a earth-friendly refrigerant and RoHS compliant
- Outdoor model operating temperature range from -40 F/-40 C to 131 F/55 C

Finish

- RAL 7035 light-gray, semi-textured powder-coat paint
- Other colors and textures available

Notes

Visit www.McLeanCoolingTech.com to download 2D and 3D CAD drawings into the overall design of your electronic system.

SPECTRACOOL™

Performance Data **G52 Models 8000/12000 BTU/Hr. (2300/3500 W)**

CATALOG NUMBER						
Indoor Model	G520816G050	G520826G050	G520846G050	G521216G050	G521226G050	G521246G050
Indoor Model Stainless Steel Type 4X	G520816G051	G520826G051	G520846G051	G521216G051	G521226G051	G521246G051
Outdoor Model without Heat Pkg.	G520816G100	G520826G100	G520846G100	G521216G100	G521226G100	G521246G100
Outdoor Model Partial Recessed Mount	G520816G101	G520826G101	G520846G101	G521216G101	G521226G101	G521246G101
Outdoor Model without Heat Pkg. Stainless Steel Type 4X	G520816G102	G520826G102	G520846G102	G521216G102	G521226G102	G521246G102
Outdoor Model with Heat Pkg.	G520816G150	G520826G150	G520846G150	G521216G150	G521226G150	G521246G150
Outdoor Model with Heat Pkg. Stainless Steel Type 4X	G520816G151	G520826G151	G520846G151	G521216G151	G521226G151	G521246G151
COOLING PERFORMANCE						
Nominal:						
BTUs/Hr.	8000	8000	8000	12000	12000	12000
Watts	2300	2300	2300	3500	3500	3500
At 131 F/131 F (55 C/55 C):						
BTUs/Hr.	7300/8200	7300/8200	8800/9800	12000/12500	12000/12500	11100/12000
Watts	2139/2403	2139/2403	2578/2871	3516/3662	3516/3662	3252/3516
At 95 F/95 F (35 C/35 C):						
BTUs/Hr.	6000/6800	6000/6800	7400/8200	9900/10700	9900/10700	9900/10700
Watts	1758/1992	1758/1992	2168/2402	2900/3135	2900/3135	2900/3135
Refrigerant	R134a	R134a	R134a	R134a	R134a	R134a
Refrigerant Charge (ounces/grams)	24/680	24/680	24/680	38/1077	38/1077	38/1077
Operating Temperature Range:						
Maximum (°F/°C)	131/55	131/55	131/55	131/55	131/55	131/55
Indoor Minimum (°F/°C)	50/10	50/10	50/10	50/10	50/10	50/10
Outdoor Minimum (°F/°C)	-40/-40	-40/-40	-40/-40	-40/-40	-40/-40	-40/-40
Airflow at 0 Static Pressure:						
Internal loop 50 Hz (CFM / m ³ /hr.)	285/484	285/484	285/484	287/487	287/487	287/487
External loop 50 Hz (CFM / m ³ /hr.)	650/1104	650/1104	650/1104	635/1078	635/1078	635/1078
Internal loop 60 Hz (CFM / m ³ /hr.)	310/527	310/527	310/527	305/518	305/518	305/518
External loop 60 Hz (CFM / m ³ /hr.)	700/1189	700/1189	700/1189	650/1104	650/1104	650/1104
Max. Heater W (Outdoor Models):	2000	2000	NA	2000	2000	NA
ELECTRICAL DATA						
Rated Voltage	115	230/208-230	400/460 3~	115	230/208-230	400/460 3~
Frequency (Hz)	50/60	50/60	50/60	50/60	50/60	50/60
Operating Range	+/- 10%	+/- 10%	+/- 10%	+/- 10%	+/- 10%	+/- 10%
Max. Power Consumption (W)	1250/1415	1250/1415	806/957*	2100/2427	1830/2130	910/1106*
Max. Nominal Current (A)	11.2/12.3	5.6/7.0-6.2	3.1/3.2	16.1/21.0	9.1/10.6-9.5	3.5/3.7
Starting Current (A)	48	27	16	57	38	16
Agency Approvals	cUL Listed CE Others available upon request					
Power Input Description	10-ft. cord with IEC connection at unit and NEMA 5-15 plug	10-ft. cord with IEC connection at unit and NEMA 6-15 plug	Terminal block	10-ft. cord with IEC connection at unit and NEMA 5-30 plug	10-ft. cord with IEC connection at unit and NEMA 6-15 plug	Terminal block
ENCLOSURE PROTECTION						
UL Type	Type 12/3R/4 standard 4X Stainless steel optional					
International Rating	IP56 internal loop IP34 external loop					
CONTROLLER						
Description	Basic mechanical thermostat with digital display					
Thermostat Location	Enclosure side on all base models					
Digital Display Location:						
Indoor Models	Ambient side					
Outdoor Models	Enclosure side					
Factory Thermostat Setting (F/C)	80/27					
SOUND LEVEL						
At 1.5 Meters	68 dB(A)					
UNIT CONSTRUCTION						
Material	Galvanized sheet metal standard Stainless steel optional					
Finish	RAL 7035 light-gray, semi-textured powder-coat paint standard Other colors available					
ACCESSORIES						
Cleanable Re-usable Filter	Aluminum mesh Part #10-1000-103					
Indoor Cutout Adapter	Enables SPECTRACOOL to be mounted to a GENESIS M52 air conditioner cutout					Part #52-6216-01
Outdoor Cutout Adapter	Enables SPECTRACOOL to be mounted to a T-Series T50 air conditioner cutout					Part #52-6216-03
UNIT DIMENSIONS						
Height (in./mm)	52.69/1338					
Width (in./mm)	17.12/435					
Depth (in./mm)	11.66/296					
Weight (lb./kg)	128/58.1	128/58.1	138/62.6	131/59.4	131/59.4	141/64.0

*Watts based on .65 power factor.

Performance Curves for G52 Models 8000 BTU/Hr. (2344 Watt)

G52-08(1/2)6-GXXX Capacity Curve 50 Hz

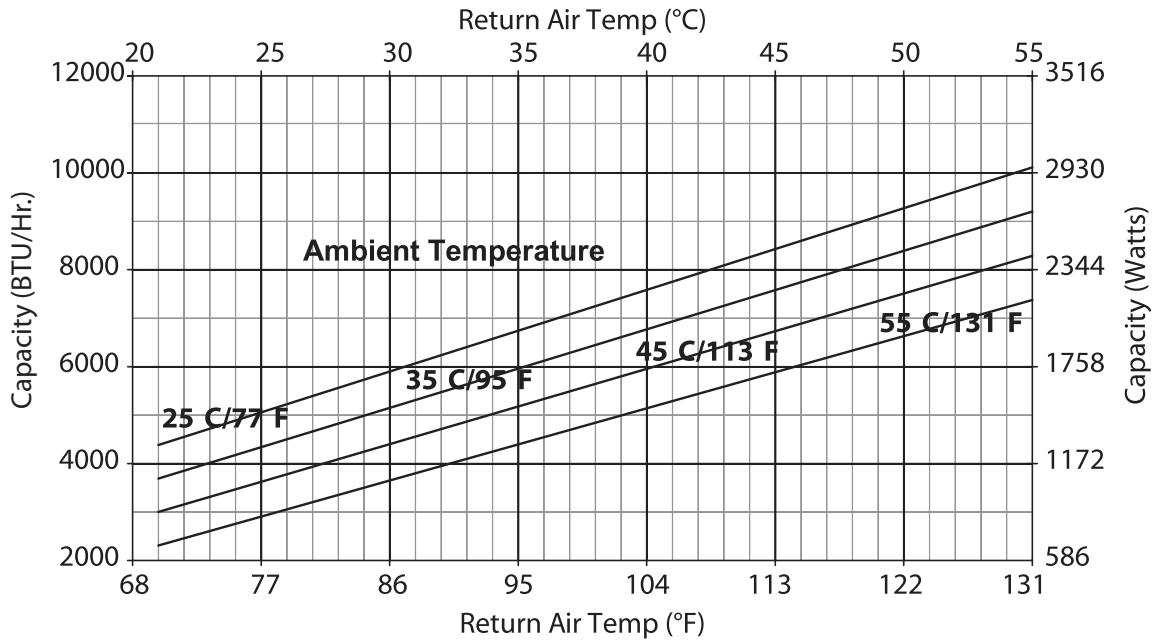

G52-08(1/2)6-GXXX Capacity Curve 60 Hz

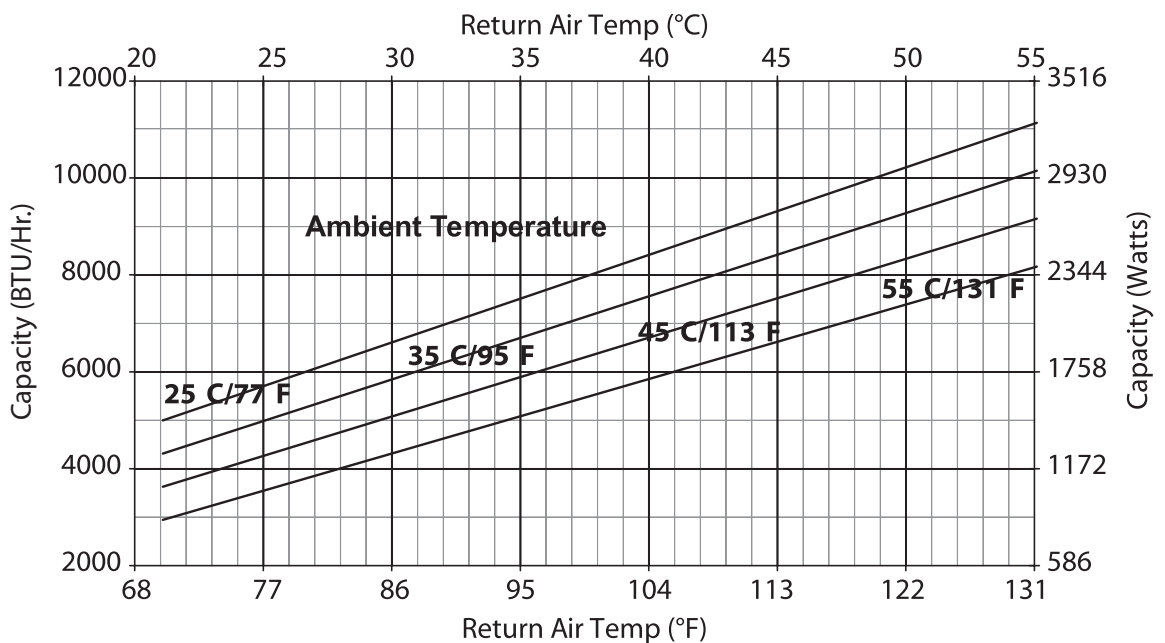

Performance Curves for G52 Models 8000 BTU/Hr. (2300 Watt)

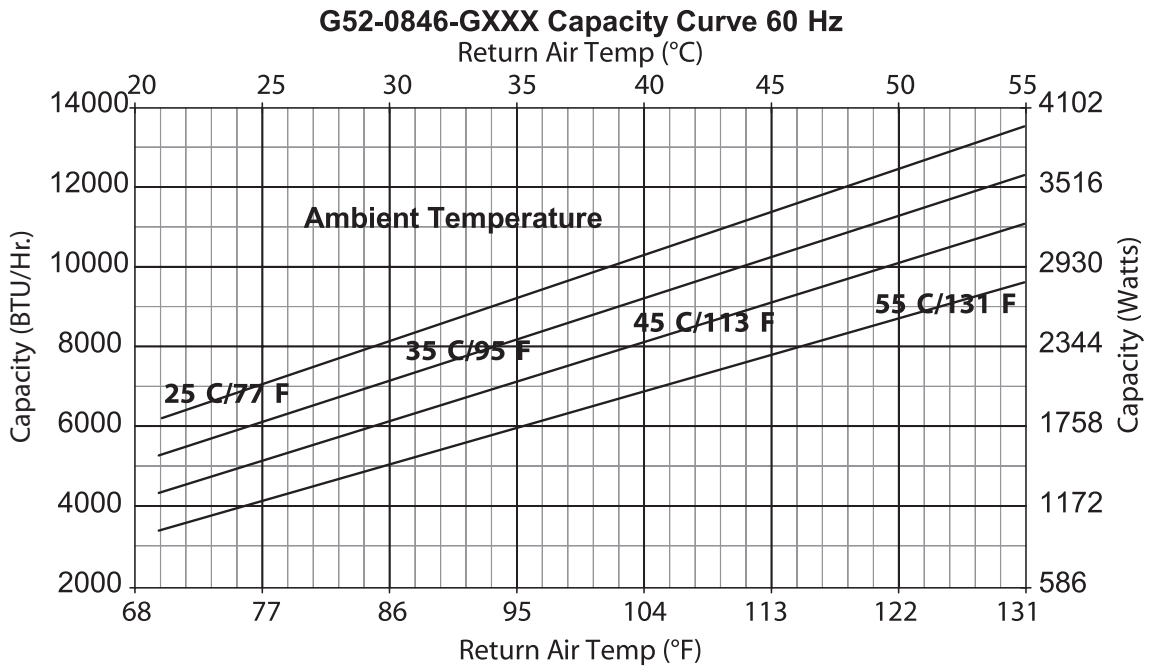
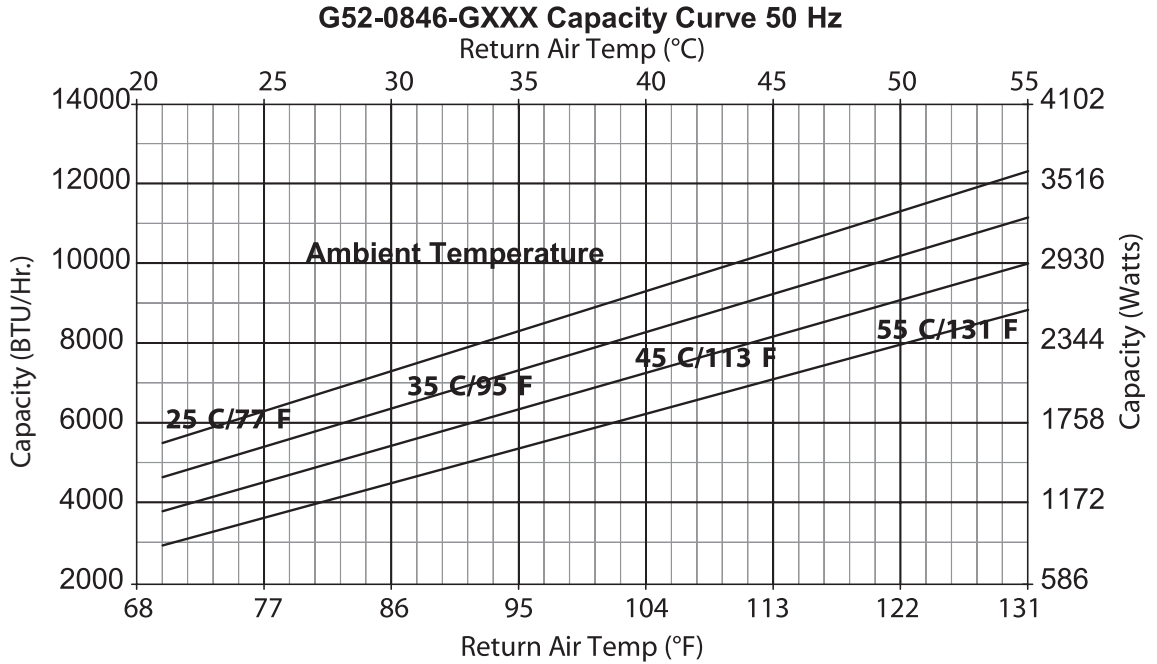

Performance Curves for G52 Models 12000 BTU/Hr. (3500 Watt)

G52-12(1/2)6-GXXX Capacity Curve 50 Hz

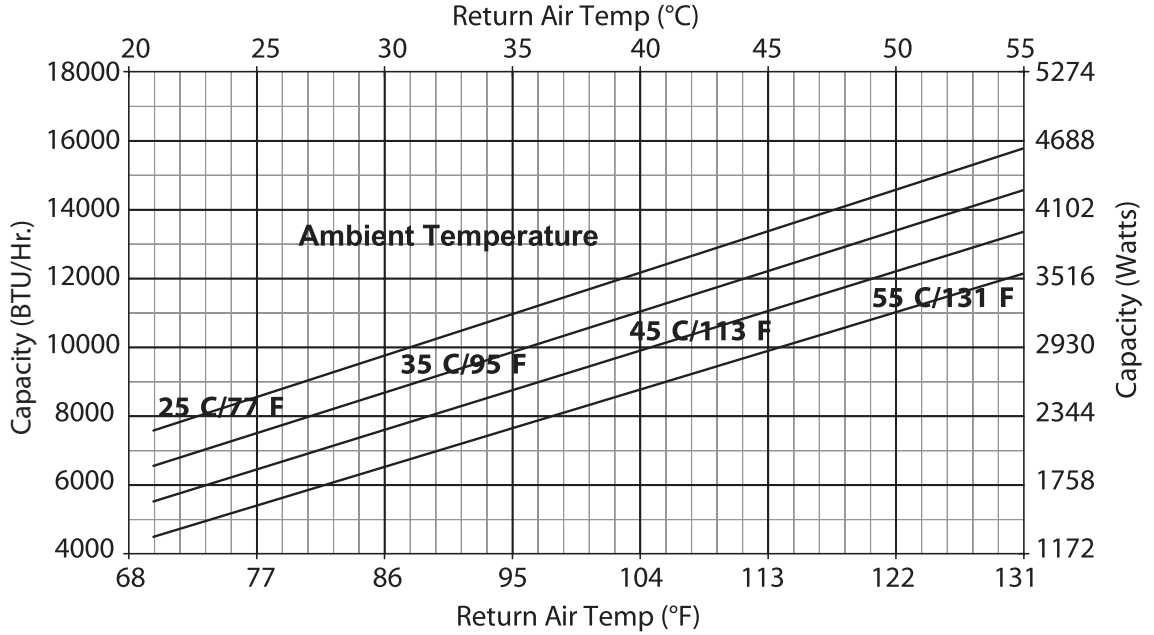

G52-12(1/2)6-GXXX Capacity Curve 60 Hz

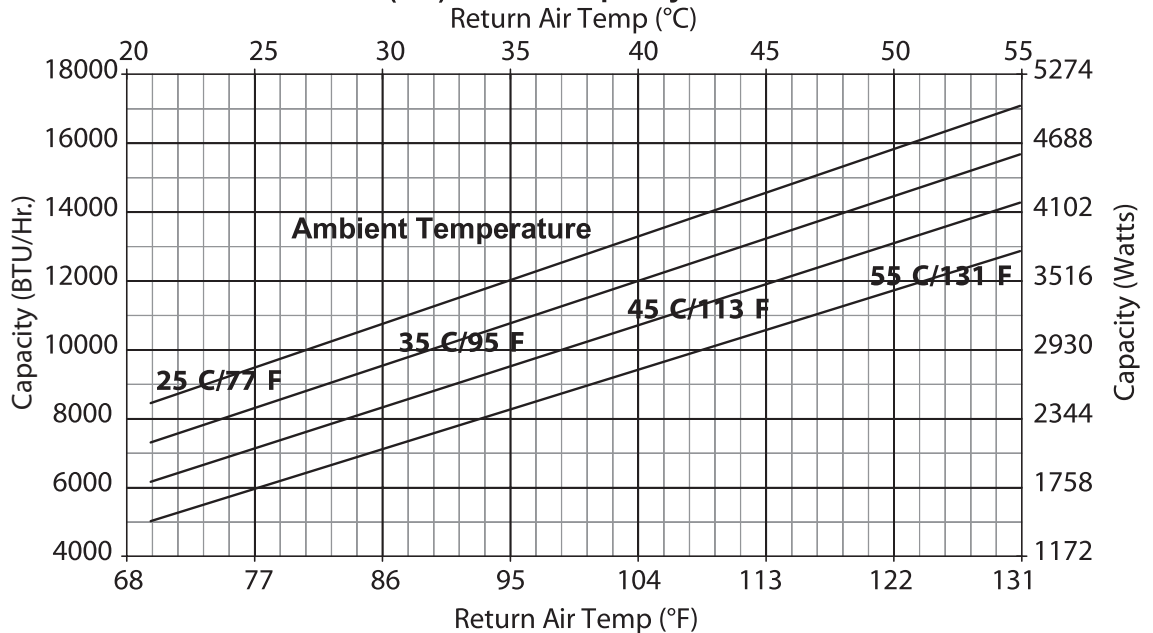

Performance Curves for G52 Models 12000 BTU/Hr. (3516 Watt)

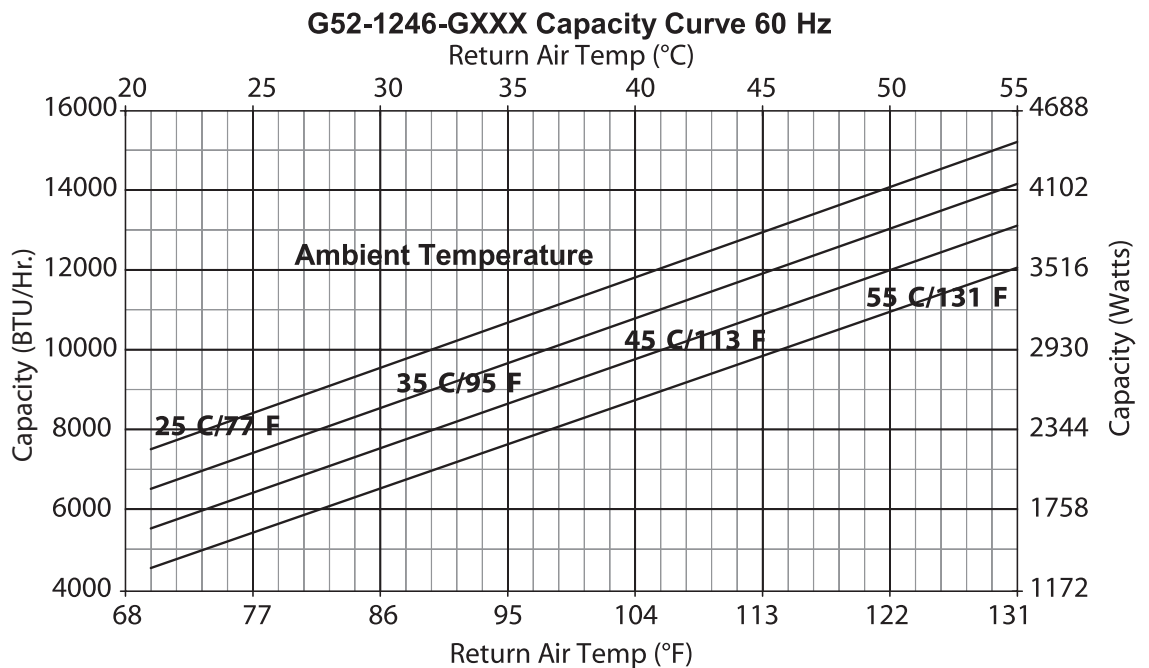
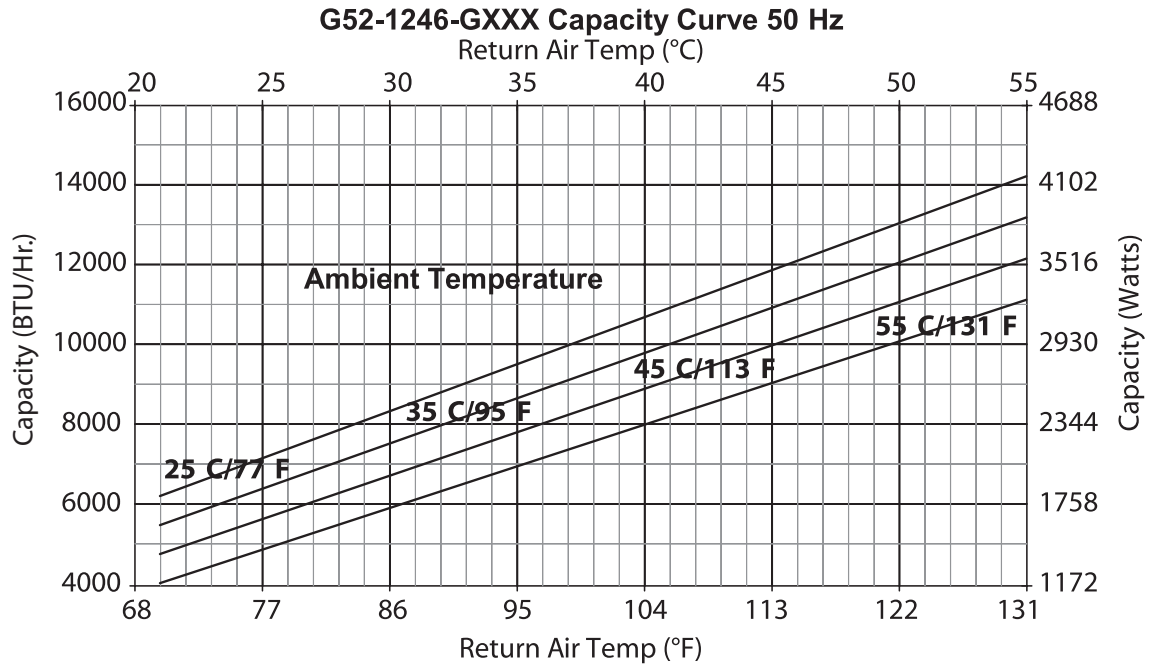

G52 Models 8000/12000 BTU/Hr. (2300/3500 Watt)

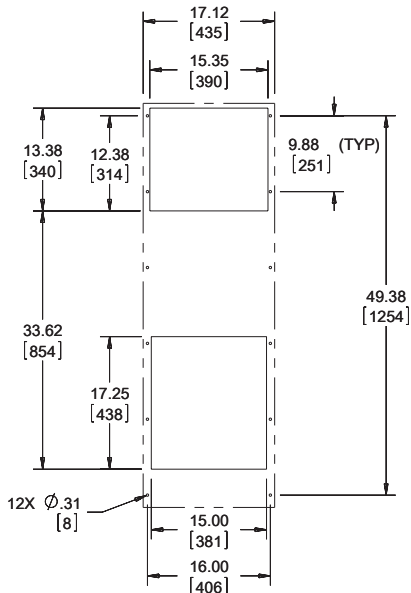
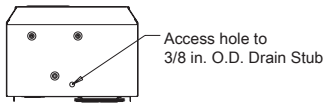
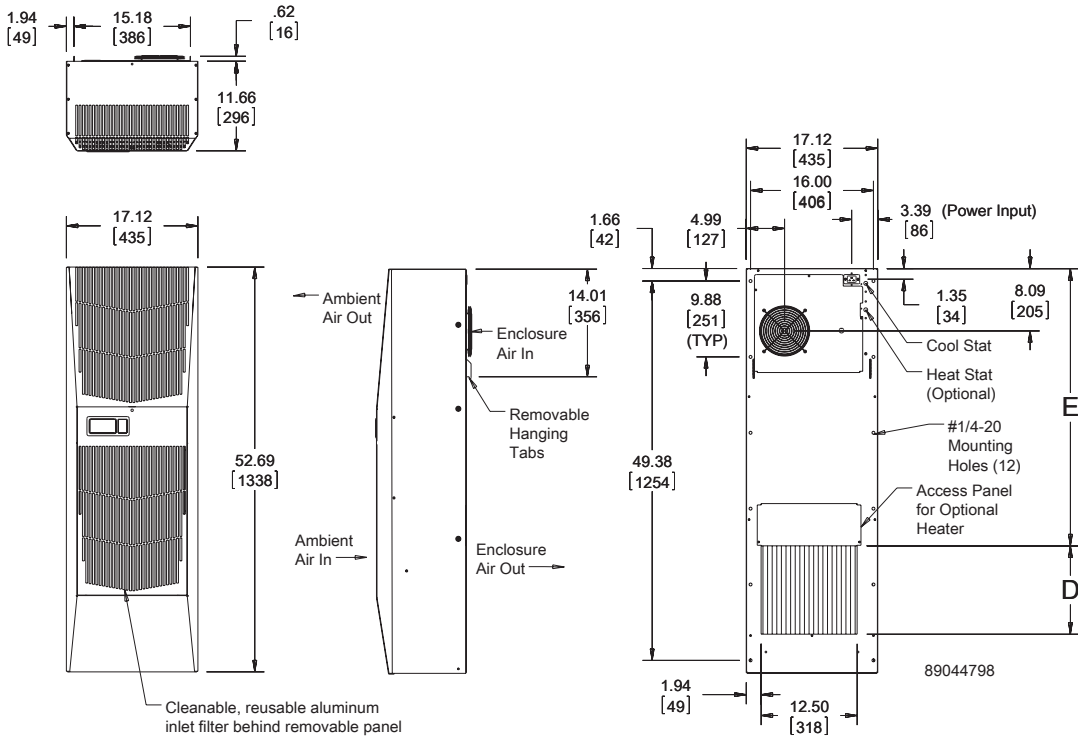

Mounting Cutout Dimensions (Standard)

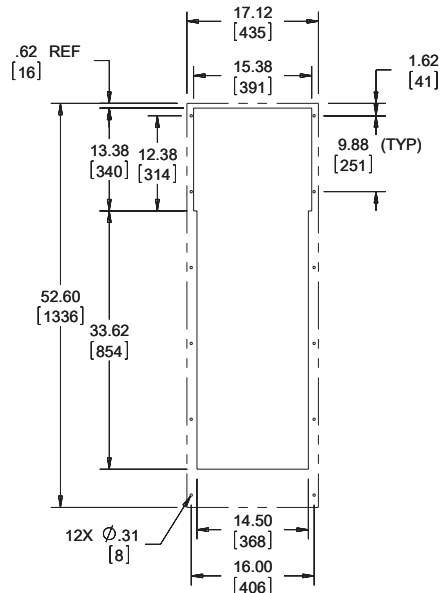

Mounting Cutout Dimensions (G52-0846-G150, G52-1246-G150 Only)

Visit www.McLeanCoolingTech.com to download 2D and 3D CAD drawings into the overall design of your electronic system.

G52 Models 8000/12000 BTU/Hr. (2344/3516 Watt) With Partial Recess

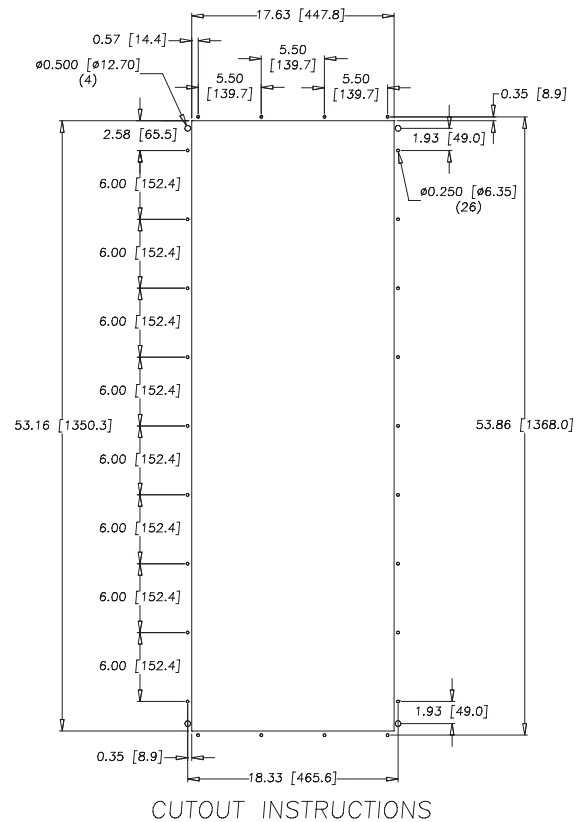
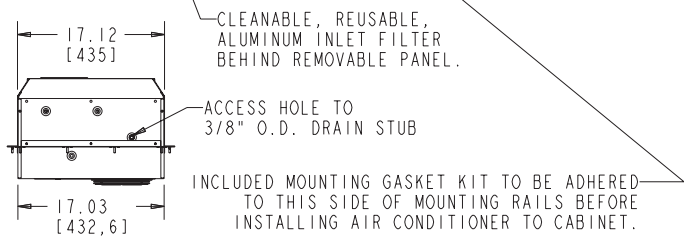
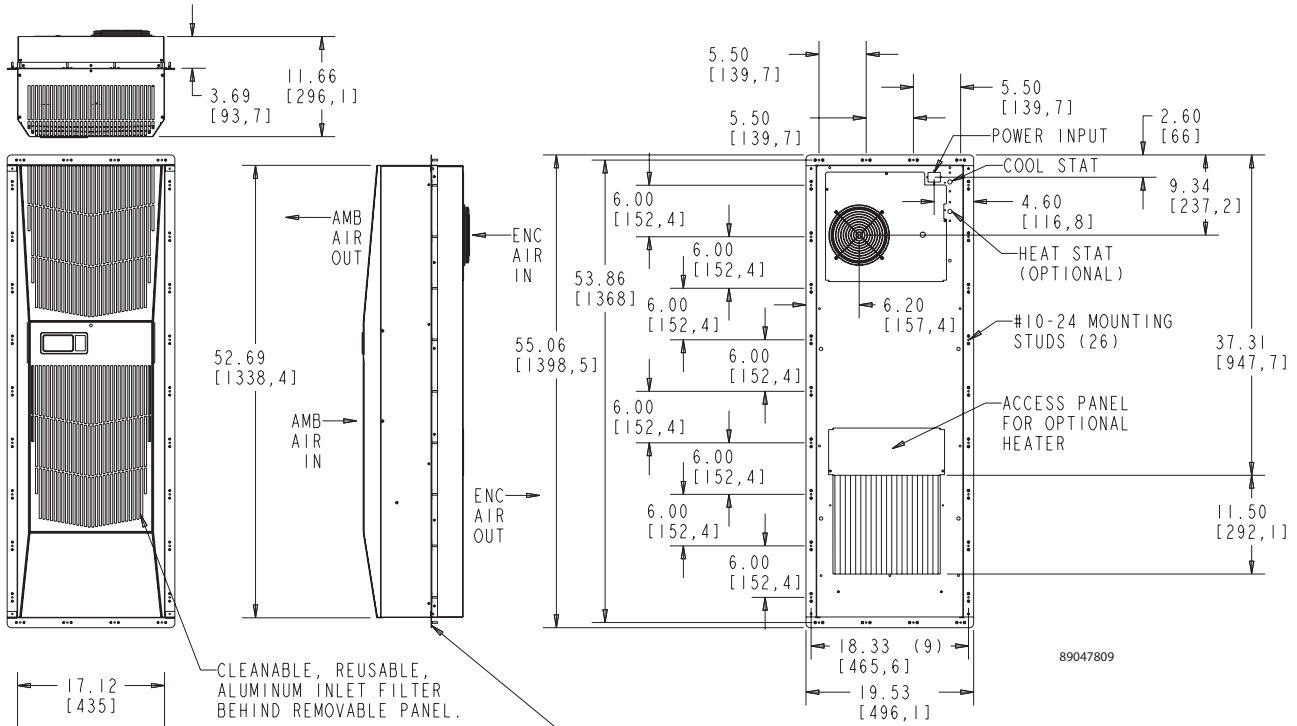

SPECTRACOOOL A/C

Visit www.McLeanCoolingTech.com to download 2D and 3D CAD drawings into the overall design of your electronic system.

G57 Indoor/Outdoor Base Models

SPECTRACOO A/C



G57 Indoor Model
20000 BTU/Hr.
5900 Watts

G57 Outdoor Model
20000 BTU/Hr.
5900 Watts

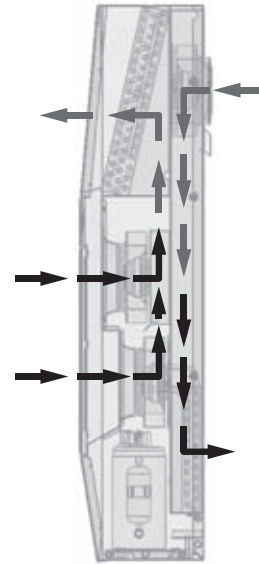

Industry Standards

UL/cUL Listed Type 12, 3R, 4; 4X optional

CE
IP 56 Internal Loop
IP 34 on External Loop
Telcordia GR-487 capable (Outdoor)

Application

- Industrial automation
- Telecommunications equipment
- Waste water treatment systems
- Package handling equipment
- Security and defense systems
- And more

Features

- Energy efficient rotary compressor
- R134a earth-friendly refrigerant and RoHS compliant
- Models for 230 and 400/460 3-phase AC volt power input
- UL Listed to save customers time and money with agency approvals
- Outdoor model operating temperature range from -40 F/-40 C to 131 F/55 C
- Exterior and partial recessed mounting options
- Attractive industrial design with minimal use of visible fasteners
- Reliable mechanical thermostat on enclosure side of the unit. Indoor Air Conditioner models include digital display on ambient side.
- Dual condenser-side air movers for performance redundancy
- Galvanized sheet-metal cover for rugged factory and outdoor environments
- Easy-mount flanges for simple installation

- Cut-out adapter options for enclosures with McLean T-Series air conditioners, enabling users to easily transition to the new unit
- Cleanable, reusable aluminum mesh filter to protect coils for maximum cooling performance
- Mounting hardware, gaskets and user manual furnished with the unit
- Every unit functionally tested before shipping
- Standard Indoor Air Conditioner models also include:
 - Active condensate management with heater strip
 - Power-off relay for door switch and other system requirements
 - Malfunction switch
- Standard Outdoor Air Conditioner models also include:
 - Telcordia GR-487 capable
 - Corrosion-resistant components
 - Malfunction switch
 - Compressor heater
 - Head pressure control
 - Maximum 3000 W enclosure heater

Specifications

- Nominal cooling capacity 20000 BTUs/Hr. (5861 W)
- R134a earth-friendly refrigerant and RoHS compliant
- Outdoor model operating temperature range from -40 F/-40 C to 131 F/55 C

Finish

- RAL 7035 light-gray, semi-textured powder-coat paint
- Other colors and textures available

Notes

Visit www.McLeanCoolingTech.com to download 2D and 3D CAD drawings into the overall design of your electronic system.

Performance Data **G57 Models 20000 BTU/Hr. (5861 W)**

CATALOG NUMBER		
Indoor Model	G572026G050	G572046G050
Indoor Model Stainless Steel Type 4X	G572026G051	G572046G051
Outdoor Model without Heat Pkg.	G572026G100	G572046G100
Outdoor Model Partial Recessed Mount	G572026G101	G572046G101
Outdoor Model without Heat Pkg. Stainless Steel Type 4X	G572026G102	G572046G102
Outdoor Model with Heat Pkg.	G572026G150	G572046G150
Outdoor Model with Heat Pkg. Stainless Steel Type 4X	G572026G151	G572046G151
COOLING PERFORMANCE		
Nominal:		
BTUs/Hr.	20000	20000
Watts	5861	5861
At 131 F/131 F (55 C/55 C):		
BTUs/Hr. (50/60 Hz)	17500/19600	21400/23400
W (50/60 Hz)	5129/5744	6272/6857
At 95 F/95 F (35 C/35 C):		
BTUs/Hr. (50/60 Hz)	16000/18000	19300/21400
W (50/60 Hz)	4689/5275	5656/6272
Refrigerant	R407c	R407c
Refrigerant Charge (ounces/grams)	50/1417	48/1361
Operating Temperature Range:		
Maximum (°F/°C)	131/55	131/55
Indoor Minimum (°F/°C)	50/10	50/10
Outdoor Minimum (°F/°C)	-40/-40	-40/-40
Airflow at 0 Static Pressure:		
Internal loop 50 Hz (CFM / m ³ /hr.)	513/872	513/872
External loop 50 Hz (CFM / m ³ /hr.)	919/1562	919/1562
Internal loop 60 Hz (CFM / m ³ /hr.)	587/998	587/998
External loop 60 Hz (CFM / m ³ /hr.)	1055/1794	1055/1794
Max. Heater W (Outdoor Models)	3000	3000
ELECTRICAL DATA		
Rated Voltage	230/230	400/460 3~
Frequency (Hz)	50/60	50/60
Operating Range	+/- 10%	+/- 10%
Max. Power Consumption (W at 50/60 Hz)	4508/5106	2400/3128
Max. Nominal Current (A at 50/60 Hz)	19.6/22.2	6.0/6.8
Starting Current (A)	63	27
Agency Approvals	cUL Listed CE Others available upon request	
Power Input Description	10-ft. cord with IEC connection at unit and NEMA 6-30 plug	Terminal block
ENCLOSURE PROTECTION		
UL Type	Type 12, 3R, 4 standard 4X stainless steel optional	
International Rating	IP56 internal loop IP34 external loop	
CONTROLLER		
Description	Basic mechanical thermostat with digital display	
Thermostat Location	Enclosure side on all base models	
Digital Display Location:		
Indoor Models	Ambient side	
Outdoor Models	Enclosure side	
Factory Thermostat Setting (°F/°C)	80/27	
SOUND LEVEL		
At 1.5 m	74.1 dB(A)	
UNIT CONSTRUCTION		
Material	Galvanized sheet metal standard Stainless steel optional	
Finish	RAL 7035 light-gray, semi-textured powder-coat paint standard	
ACCESSORIES		
Cleanable Re-usable Filter	Aluminum mesh part #10-1000-103 BA	
Outdoor Model Cutout Adapter	Enables SPECTRACOO™ to be mounted to a T-Series T53 air conditioner cut-out part #57-7216-01	
UNIT DIMENSIONS		
Height (in./mm)	57.69/1465.4	
Width (in./mm)	20.87/530.1	
Depth (in./mm)	15.28/388.1	
Weight (lb./kg)	197/89	

Performance Curves for G57 Models 20000 BTU/Hr.

G57-2026-GXXX Capacity Curve 50 Hz

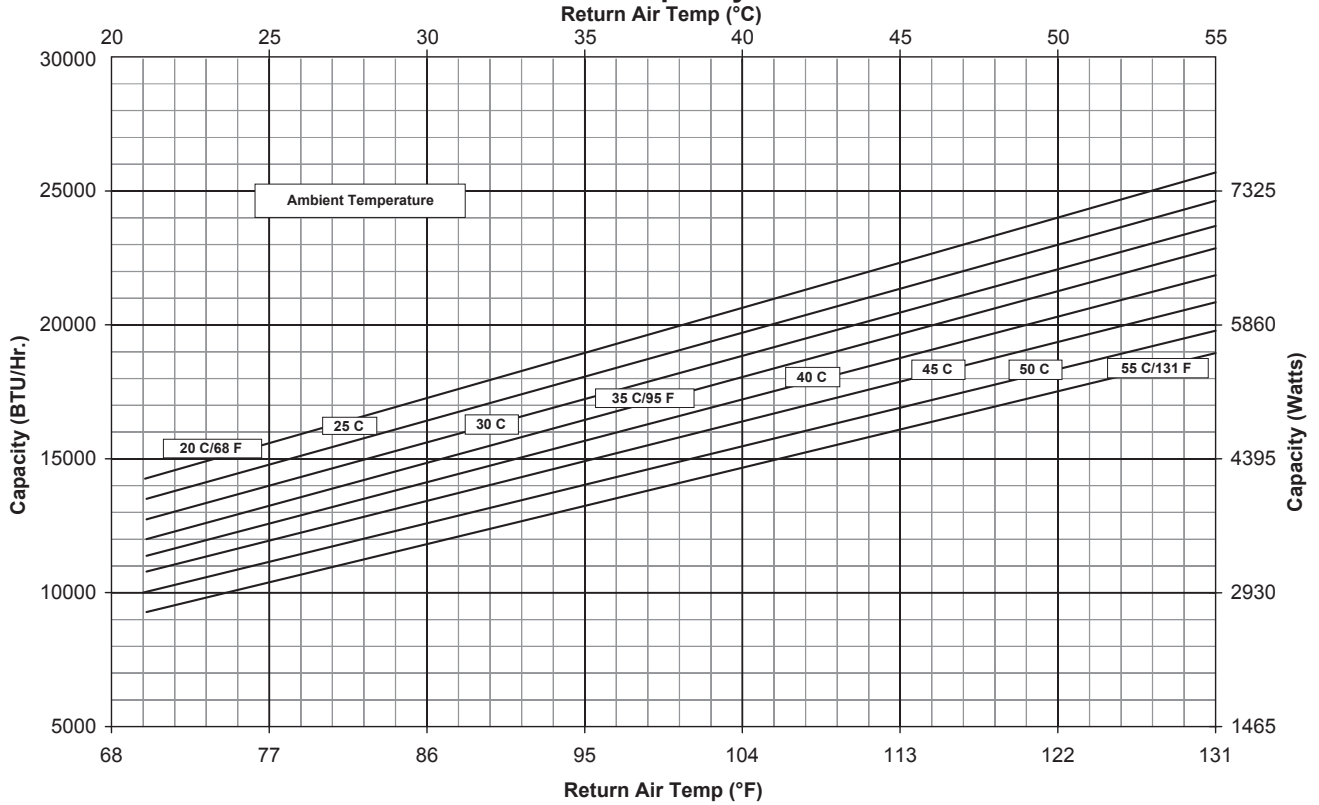

G57-2026-GXXX Capacity Curve 60 Hz

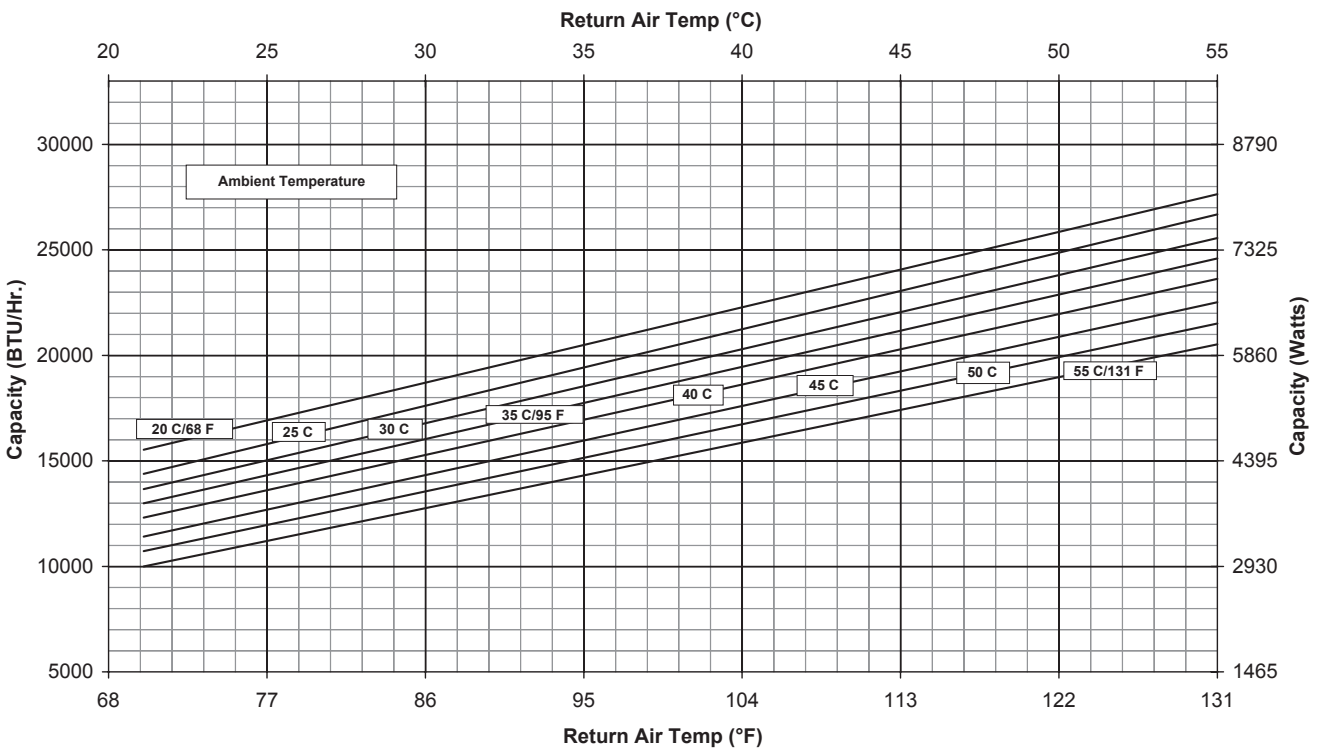

SPECTRACOOOL A/C

Performance Curves for G57 Models 20000 BTU/Hr.

G57-2046-GXXX Capacity Curve 50 Hz

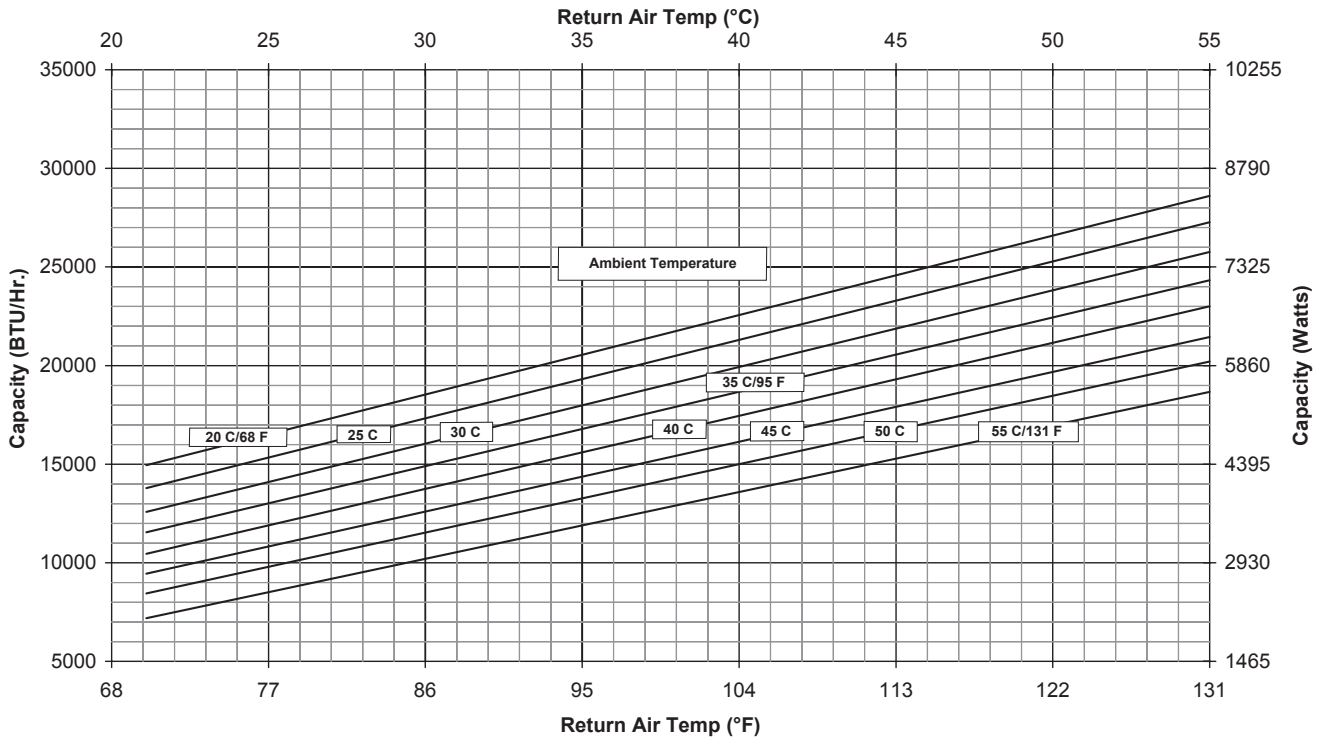

G57-2046-GXXX Capacity Curve 60 Hz

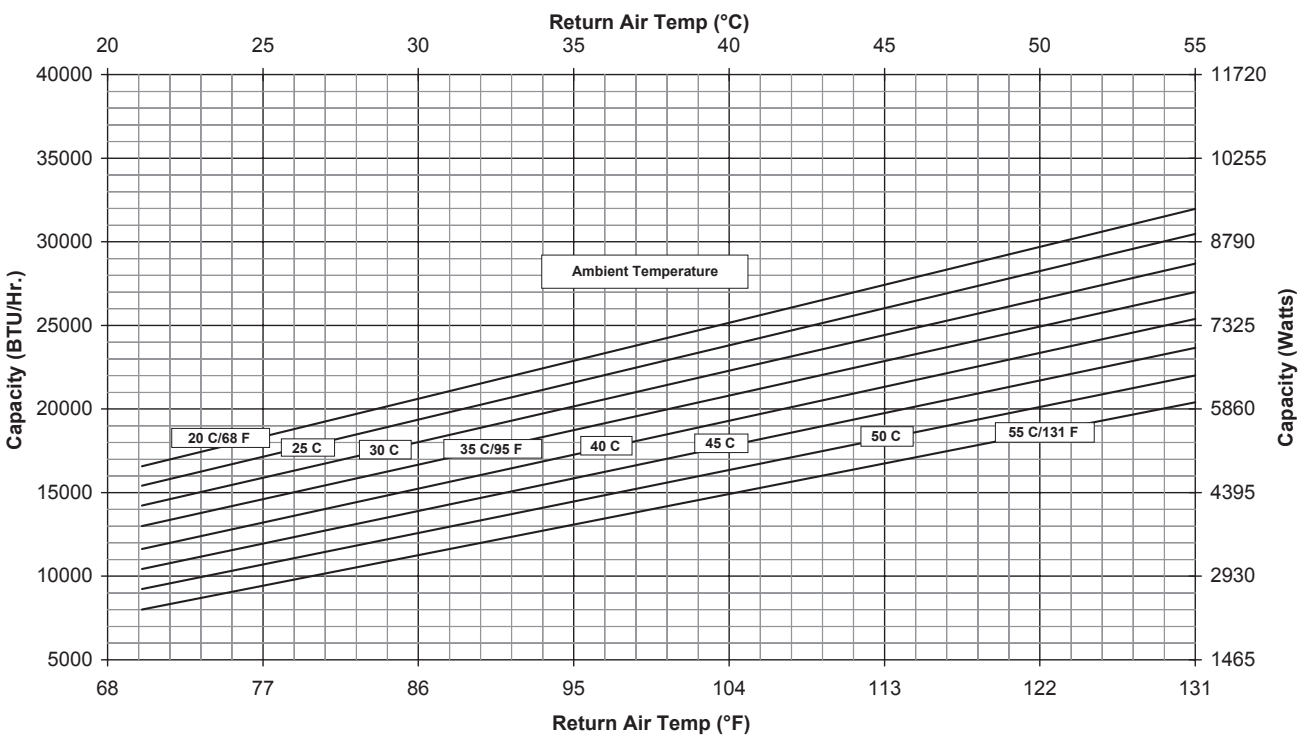

G57 Models 20000 BTU/Hr. (5861 Watt)

SPECTRACOOL A/C

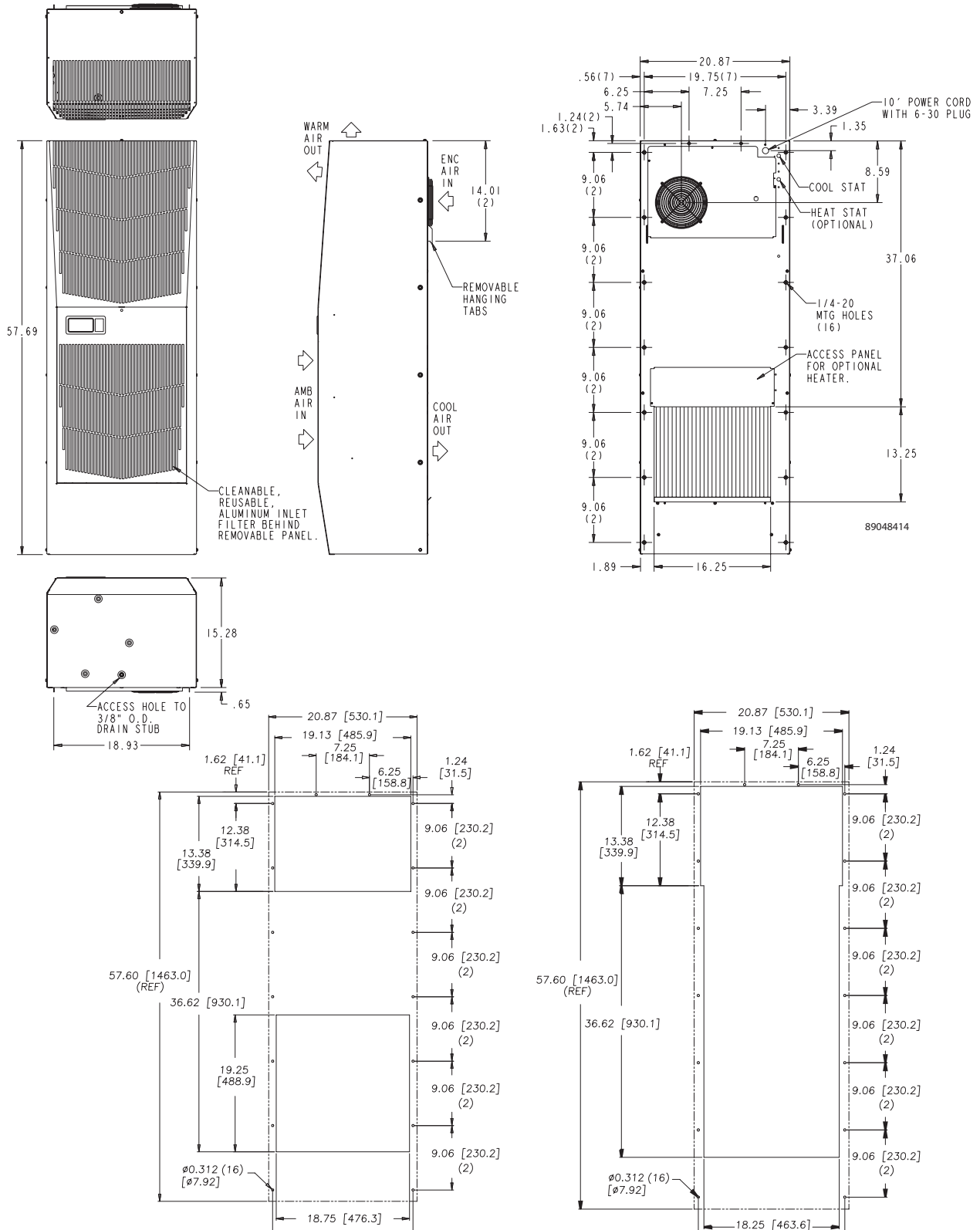

Visit www.McLeanCoolingTech.com to download 2D and 3D CAD drawings into the overall design of your electronic system.

G57 Models 20000 BTU/Hr. (5861 Watt) With Partial Recess

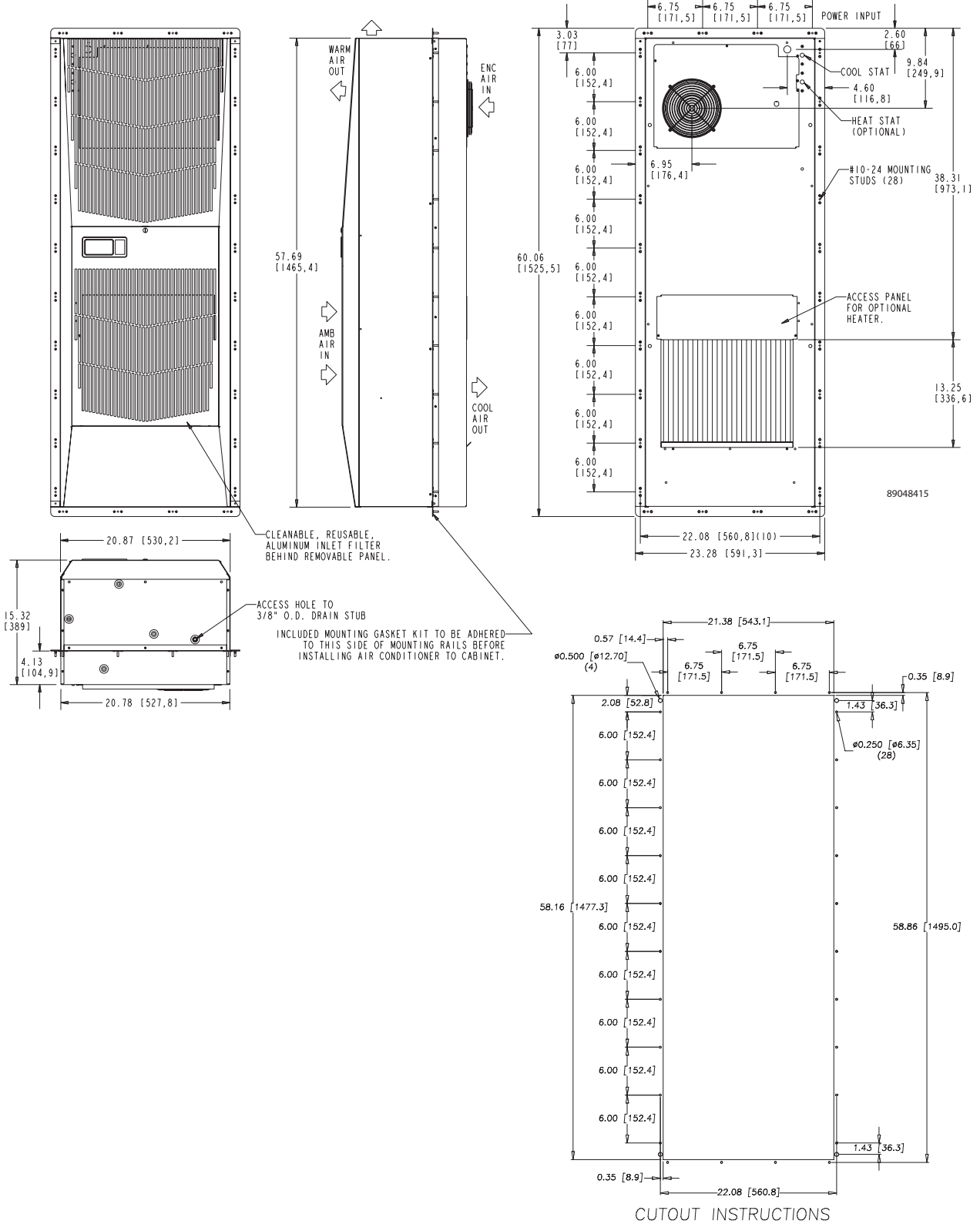

SPECTRACOOL A/C

Visit www.McLeanCoolingTech.com to download 2D and 3D CAD drawings into the overall design of your electronic system.

T-Series[™] Indoor/Outdoor Air Conditioner



T29 Model



T53 Model



*T70 Model
(3 ton)*

Keeps its cool during peak heat loads and hot weather



T-Series™ Indoor/Outdoor Air Conditioners

PRODUCT OVERVIEW

The perfect cooling system where precise temperature control is needed. Built rugged to perform in extremely hot and cold ambient temperatures. Engineered to seal out virtually any bad weather.

APPLICATIONS

- Telecommunications cabinets and shelters
- Transportation controls
- Outdoor security systems
- Mobile communications systems
- Other outdoor electronics applications

T-Series Chapter Contents

Indoor/Outdoor Air Conditioners.....	42
T15 Model 800 BTU	43
T20 Model 2000 BTU.....	46
T29 Model 4000 BTU	49
T43 Model 6000 BTU.....	52
T43 Model 8000 BTU.....	54
T43 Model 10000 BTU.....	56
T50 Model 12000 BTU	59
T53 Model 19000 BTU	62
T62 Model 20000 BTU	65
T70-36 Model 36000 BTU	68
T70-60 Model 59000 BTU	71

T-Series

Indoor/Outdoor Air Conditioners

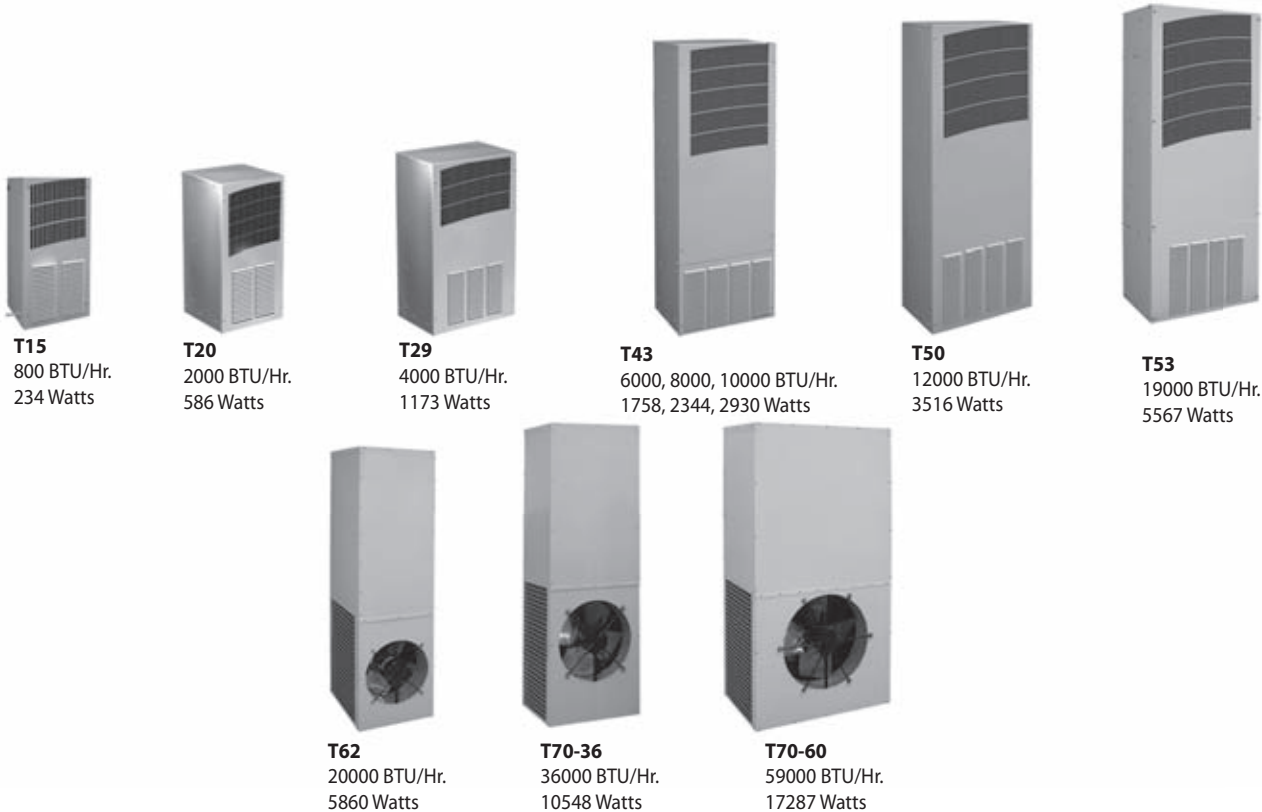

T-Series A/C

Industry Standards

UL/cUL Listed

- CE
- Type 12/3R/4
- Type 4X stainless steel option
- Telcordia GR-487 capable

Application

- Industrial automation
- Telecommunications equipment
- Package handling equipment
- Security and defense systems
- And more

Features

- Stock models equipped with head pressure control for low-ambient operation, compressor heater, coated condenser coil, malfunction switch, thermostat and heater package
- R134A or R-407C earth-friendly refrigerant and RoHS compliant
- Models for 115, 230 and 460 Volt AC power input
- UL Listed to save customers time and money with agency approvals (some models UL recognized)
- Outdoor model operating temperature range from -40 F/-40 C to 131 F/55 C
- Exterior and fully recessed mounting options on many models
- Compact footprint to minimize real estate and maximize capacity
- Reliable mechanical thermostat on enclosure side of the unit
- Dual condenser-side air movers for performance redundancy
- Painted galvanized sheet-metal cover for rugged factory and outdoor environments
- Easy-mount flanges for simple installation

- Cleanable, reusable aluminum mesh filter to protect coils for maximum cooling performance
- Mounting hardware, gaskets and user manual furnished with the unit
- Every unit functionally tested before shipping
- Standard Outdoor Air Conditioner models also include:
 - Telcordia GR-487 capable
 - Thermostat
 - Corrosion-resistant components
 - Malfunction switch
 - Compressor heater
 - Head pressure control
 - Enclosure heater

Finish

- RAL 7035 light-gray, semi-textured powder-coat paint
- Other colors and textures available

Options

- Thermostat Malfunction Package
 - Special Voltage Package
 - Outdoor Package
 - Harsh Environment Package*
 - Stainless Steel Package*
 - Heater Package
- * PROAIR A/C may be more appropriate. Refer to PROAIR A/C Chapter. Consult the Factory for availability and catalog number.

Notes

Visit www.McLeanCoolingTech.com to download 2D and 3D CAD drawings into the overall design of your electronic system.

T-Series

Performance Data T15 800 BTU/Hr. (234 W) Models

CATALOG NUMBER	T150116G150	T150126G150
COOLING PERFORMANCE		
Nominal:		
BTUs/Hr.	800/800	800/900
Watts	235/235	235/264
At 131 F/131 F (55 C/55 C):		
BTUs/Hr. (50/60 Hz)	819	920/960
W (50/60 Hz)	240	270/281
At 95 F/95 F (35 C/35 C):		
BTUs/Hr. (50 /60 Hz)	948	810/955
W (50/60 Hz)	278	237/280
Refrigerant	R-134A	R-134A
Refrigerant Charge (ounces/grams)	4/113	3.8/107
Operating Temperature Range:		
Maximum (°F/°C)	131/55	125/131/52/55
Minimum (°F/°C)	-40/-40	-40/-40
Airflow at 0 Static Pressure:		
Internal loop 50 Hz (CFM/m ³ /hr.)	25/42	25/42
External loop 50 Hz (CFM/m ³ /hr.)	48/82	48/82
Internal loop 60 Hz (CFM/m ³ /hr.)	30/51	30/51
External loop 60 Hz (CFM/m ³ /hr.)	53/90	53/90
Max. Heater W (Outdoor Models)	150	150
ELECTRICAL DATA		
Rated Voltage	100/115	220/230
Frequency (Hz)	50/60	50/60
Operating Range	+/- 10%	+/- 10%
Max. Power Consumption (W at 50/60 Hz)	360/403	330/345
Max. Nominal Current (A at 50/60 Hz)	3.6/3.5	1.5/1.5
Starting Current (A)	8.0/9.2	3.3/3.1
Agency Approvals	cUL Listed CE Others available upon request	
Power Input Description	6-ft. cord with NEMA 5-15 plug	6-ft. cord with NEMA 6-15 plug
ENCLOSURE PROTECTION		
UL Type	Type 12/3R/4 standard 4X Stainless steel optional	
CONTROLLER		
Description	Basic mechanical thermostat	
Thermostat Location	Enclosure behind front panel	
Factory Thermostat Setting (°F/°C)	80/27	
SOUND LEVEL		
At 1.5 Meters	63 dB(A)	
UNIT CONSTRUCTION		
Material	Galvanized sheet metal standard Stainless steel optional	
Finish	RAL 7035 light-gray, semi-textured powder-coat paint standard	
UNIT DIMENSIONS		
Height (in./mm)	15.75/400	
Width (in./mm)	7.5/191	
Depth (in./mm)	6.3/160	
Weight (lb./kg)	27/12	

T-Series A/C

T-Series

Performance Curves for T15 Models 800 BTU/Hr. (234 Watt)

T15-01x6-Gxxx Capacity Curves 50 Hz

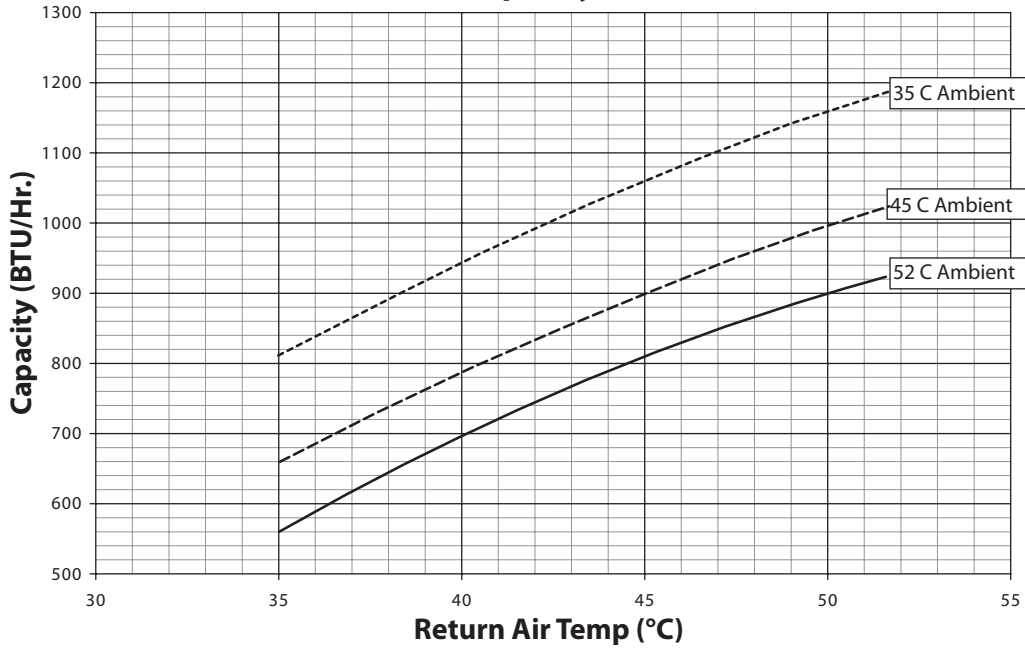

T15-01x6-Gxxx Capacity Curves 60 Hz

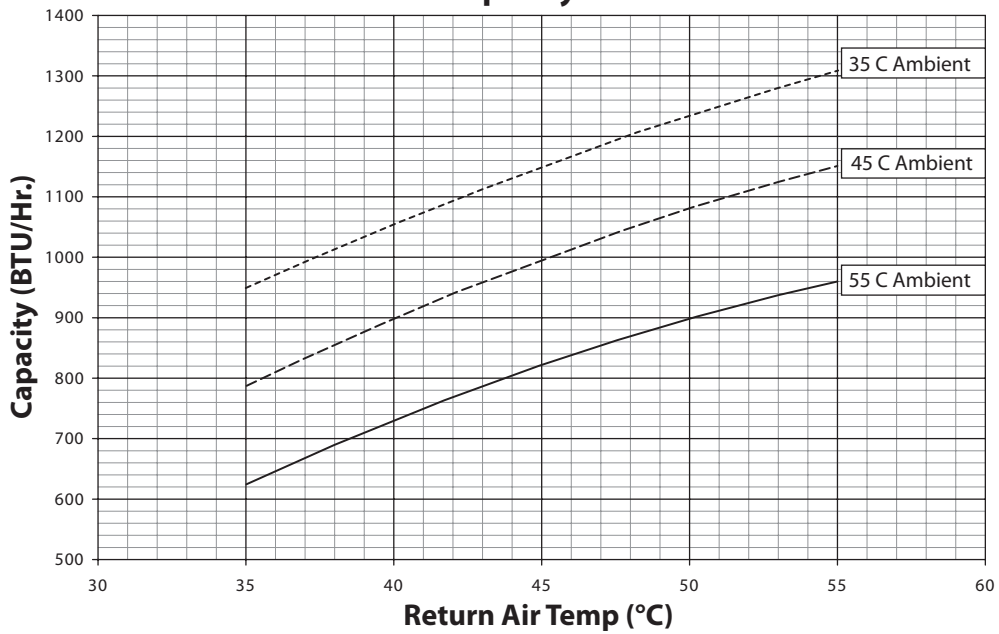

T-Series

T15 Models 800 BTU/Hr. (234 Watt)

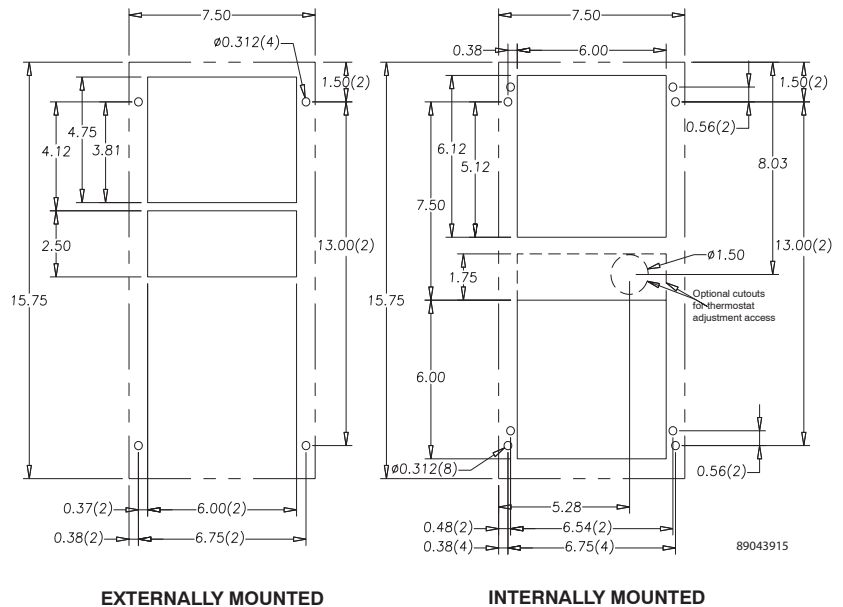
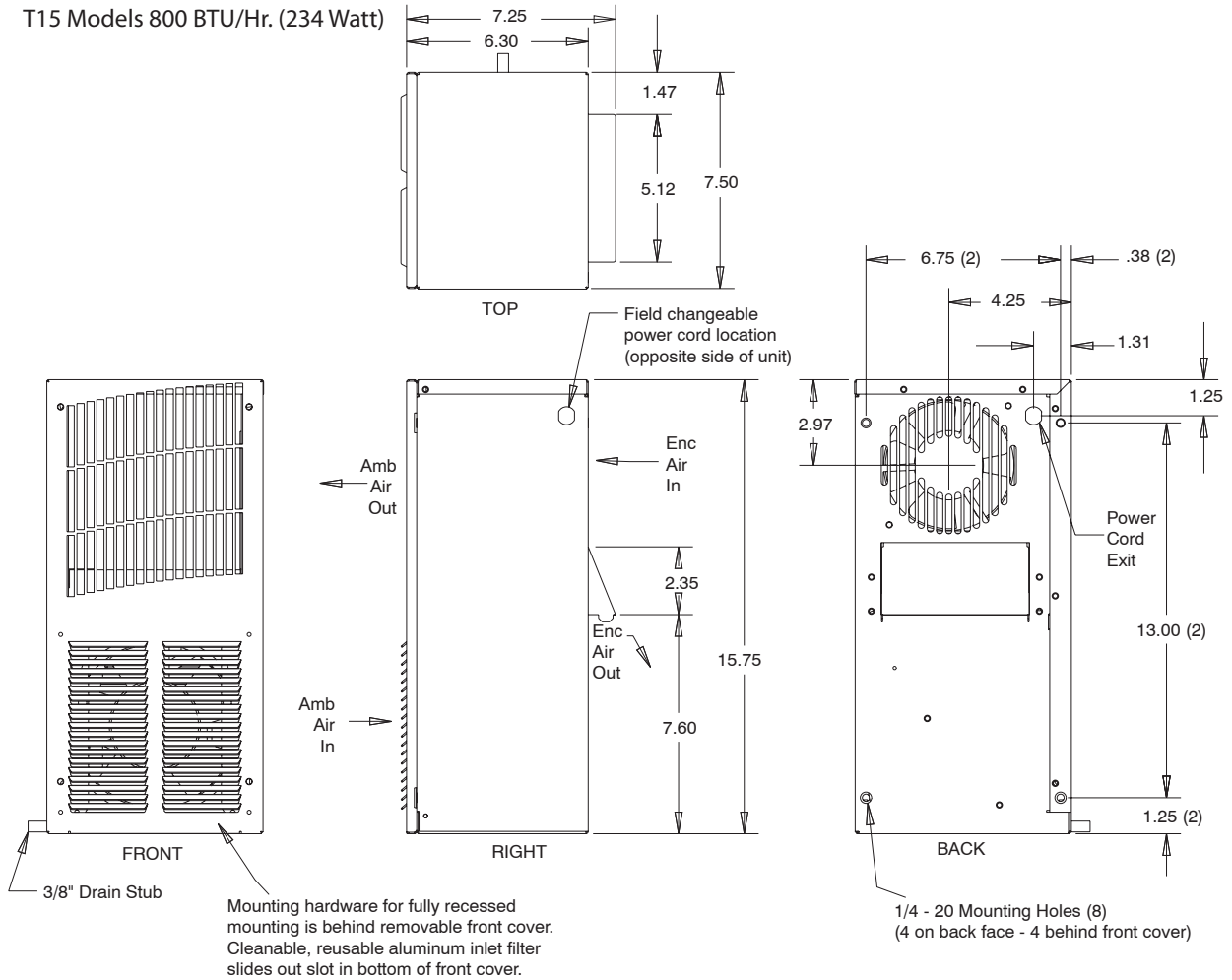

T-Series A/C

Visit www.McLeanCoolingTech.com to download 2D and 3D CAD drawings into the overall design of your electronic system.

T-Series

Performance Data T20 2000 BTU/Hr. (586 W) Models

CATALOG NUMBER	T200216G150	T200226G150	T200246G400
COOLING PERFORMANCE			
Nominal:			
BTUs/Hr.	1800/2000	1800/2000	1800/2000
Watts	528/586	528/586	528/586
At 131 F/131 F (55 C/55 C):			
BTUs/Hr. (50/60 Hz)	2000/2175	2000/2175	2000/2175
W (50/60 Hz)	586/637	586/637	586/637
At 95 F/95 F (35 C/35 C):			
BTUs/Hr. (50/60 Hz)	1950/2200	1950/2200	1950/2200
W (50/60 Hz)	571/645	571/645	571/645
Refrigerant	R-134A	R-134A	R-134A
Refrigerant Charge (ounces/grams)	6.7/190	6.7/190	6.7/190
Operating Temperature Range:			
Maximum (°F/°C)	131/55	131/55	131/55
Minimum (°F/°C)	-40/-40	-40/-40	-40/-40
Airflow at 0 Static Pressure:			
Internal loop 50 Hz (CFM/m ³ /hr.)	77/131	77/131	77/131
External loop 50 Hz (CFM/m ³ /hr.)	150/255	150/255	150/255
Internal loop 60 Hz (CFM/m ³ /hr.)	91/155	91/155	91/155
External loop 60 Hz (CFM/m ³ /hr.)	165/280	165/280	165/280
Max. Heater W (Outdoor Models)	500	500	500
ELECTRICAL DATA			
Rated Voltage	115	230	460V 1PH
Frequency (Hz)	50/60	50/60	50/60
Operating Range	+/- 10%	+/- 10%	+/- 10%
Max. Power Consumption (W at 50/60 Hz)	700/805	805	874
Max. Nominal Current (A at 50/60 Hz)	7.0/7.0	3.5/3.5	1.9
Starting Current (A)	28	14.4	7.2
Agency Approvals	cUL Listed CE		cUR CE
Others available upon request			
Power Input Description	6-ft. cord with NEMA 5-15 plug	6-ft. cord with NEMA 6-15 plug	6-ft. cord with wire leads
ENCLOSURE PROTECTION			
UL Type	Type 12/3R/4 standard 4X Stainless steel optional		
CONTROLLER			
Description	Basic mechanical thermostat		
Thermostat Location	Enclosure side on all base models		
Factory Thermostat Setting (°F/°C)	80/27		
SOUND LEVEL			
At 1.5 Meters	66 dB(A)		
UNIT CONSTRUCTION			
Material	Galvanized sheet metal standard Stainless steel optional		
Finish	RAL 7035 light-gray, semi-textured powder-coat paint standard		
UNIT DIMENSIONS			
Height (in./mm)	20/508	20/508	24.25/615.95
Width (in./mm)	10/254	10/254	10/254
Depth (in./mm)	9.9/251	9.9/251	9.9/251
Weight (lb./kg)	56/25	56/25	66/30

T-Series

Performance Curves for T20 Models 2000 BTU/Hr. (586 Watt)

T20-02x6-Gxxx Capacity Curves 50 Hz

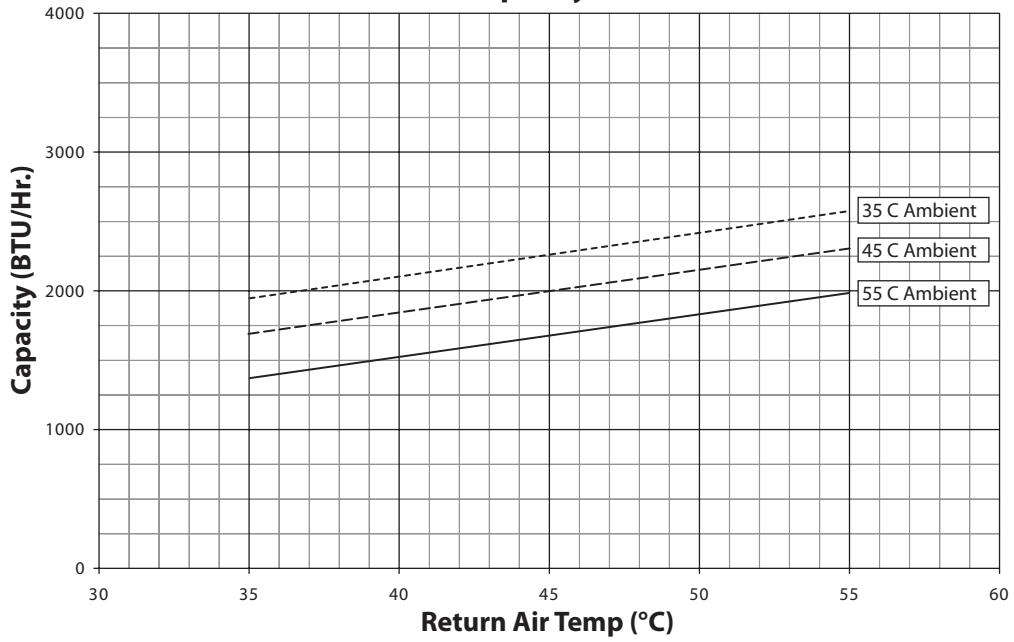

T20-02x6-Gxxx Capacity Curves 60 Hz

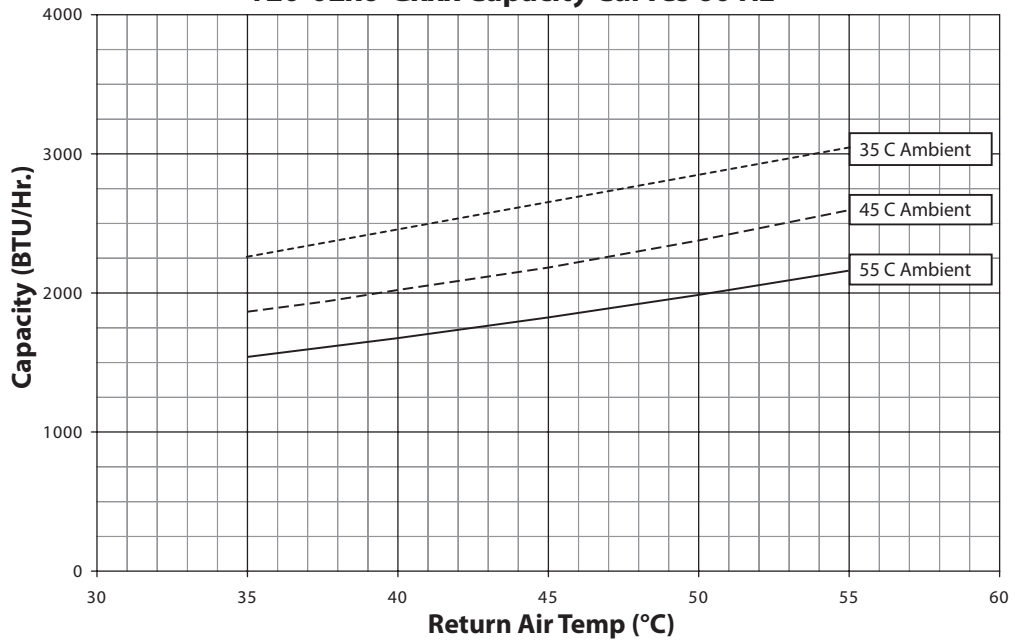

T-Series A/C

T-Series

T20 Models 2000 BTU/Hr. (586 Watt)

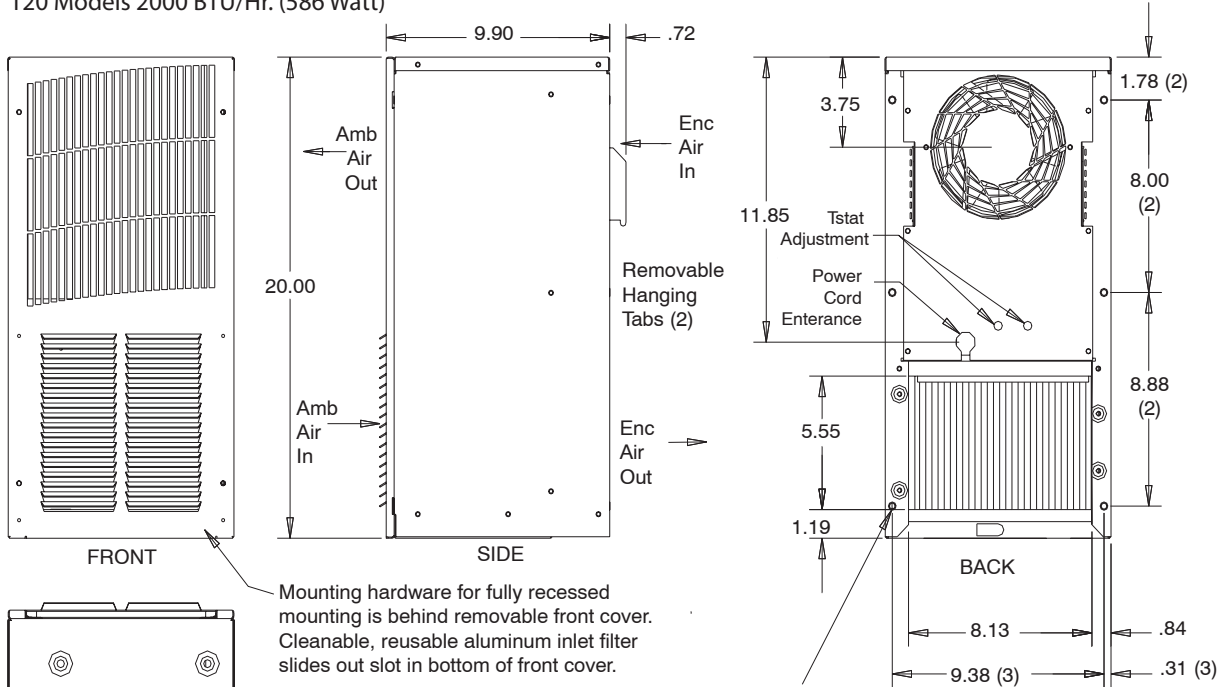

Mounting hardware for fully recessed mounting is behind removable front cover. Cleanable, reusable aluminum inlet filter slides out slot in bottom of front cover.

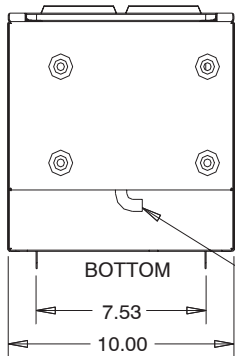

1/4 - 20 Mounting Holes (12)
(6 on back face - 6 behind front cover)

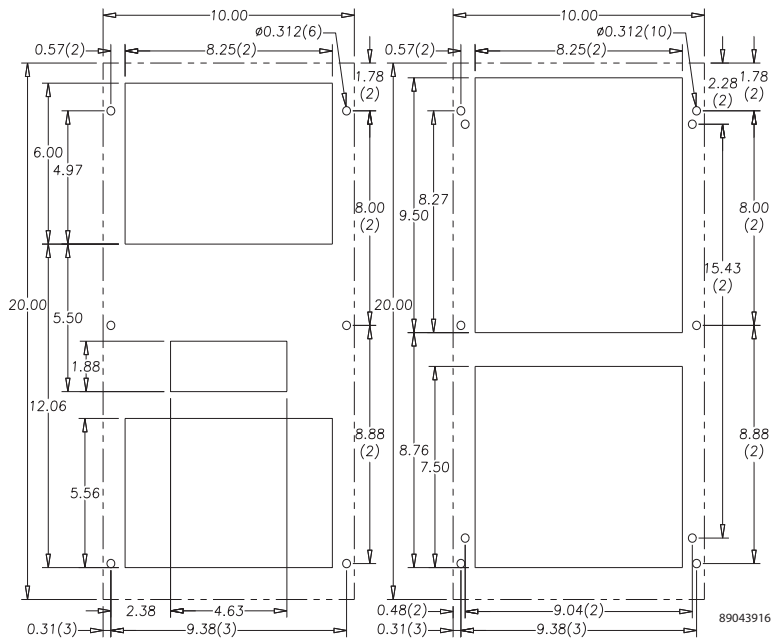

CUTOUT INSTRUCTIONS
(As viewed from outside of enclosure)

NOTES:
1. Dashed lines represent air conditioner.

Visit www.McLeanCoolingTech.com to download 2D and 3D CAD drawings into the overall design of your electronic system.

T-Series

Performance Data **T29 4000 BTU/Hr. (1173 W) Models**

CATALOG NUMBER	T290416G150	T290426G150	T290446G400
COOLING PERFORMANCE			
Nominal:			
BTUs/Hr.	3600/4000	3600/4000	3600/4000
Watts	1055/1172	1055/1172	1055/1172
At 131 F/131 F (55 C/55 C):			
BTUs/Hr. (50/60 Hz)	3950/4250	3950/4250	3950/4250
W (50/60 Hz)	1157/1245	1157/1245	1157/1245
At 95 F/95 F (35 C/35 C):			
BTUs/Hr. (50 /60 Hz)	3500/3900	3500/3900	3500/3900
W (50/60 Hz)	1025/1143	1025/1143	1025/1143
Refrigerant	R-134A	R-134A	R-134A
Refrigerant Charge (ounces/grams)	14.3/404	14.3/404	14.3/404
Operating Temperature Range:			
Maximum (°F/°C)	131/55	131/55	131/55
Minimum (°F/°C)	-40/-40	-40/-40	-40/-40
Airflow at 0 Static Pressure:			
Internal loop 50 Hz (CFM/m ³ /hr.)	172/292	172/292	172/292
External loop 50 Hz (CFM/m ³ /hr.)	195/331	195/331	195/331
Internal loop 60 Hz (CFM/m ³ /hr.)	205/348	205/348	205/348
External loop 60 Hz (CFM/m ³ /hr.)	235/399	235/399	235/399
Max. Heater W (Outdoor Models)	1000	1000	
ELECTRICAL DATA			
Rated Voltage	115	230	460V 1PH
Frequency (Hz)	50/60	50/60	50/60
Operating Range	+/- 10%	+/- 10%	+/- 10%
Max. Power Consumption (W at 50/60 Hz)	1587/1564	1587/1564	1748
Max. Nominal Current (A at 50/60 Hz)	13.8/13.6	6.9/6.8	3.8
Starting Current (I)	48	23	12
Agency Approvals		cUL Listed CE	cUR Recognized CE
Others available upon request			
Power Input Description	6-ft. cord with NEMA 5-20 plug	6-ft. cord with NEMA 6-15 plug	6-ft. cord with wire leads
ENCLOSURE PROTECTION			
UL Type	Type 12/3R/4 standard 4X Stainless steel optional		
CONTROLLER			
Description	Basic mechanical thermostat		
Thermostat Location	Enclosure side on all base models		
Factory Thermostat Setting (°F/°C)	80/27		
SOUND LEVEL			
At 1.5 M	67 dB(A)		
UNIT CONSTRUCTION			
Material	Galvanized sheet metal standard Stainless steel optional		
Finish	RAL 7035 light-gray, semi-textured powder-coat paint standard		
UNIT DIMENSIONS			
Height (in./mm)	29/737	29/737	29/737
Width (in./mm)	17/432	17/432	17/432
Depth (in./mm)	11.3/287	11.3/287	11.3/287
Weight (lb./kg)	107/48.6	107/48.6	127/58

T-Series

Performance Curves for T29 Models 4000 BTU/Hr. (1173 Watt)

T29-04x6-Gxxx Capacity Curves 50 Hz

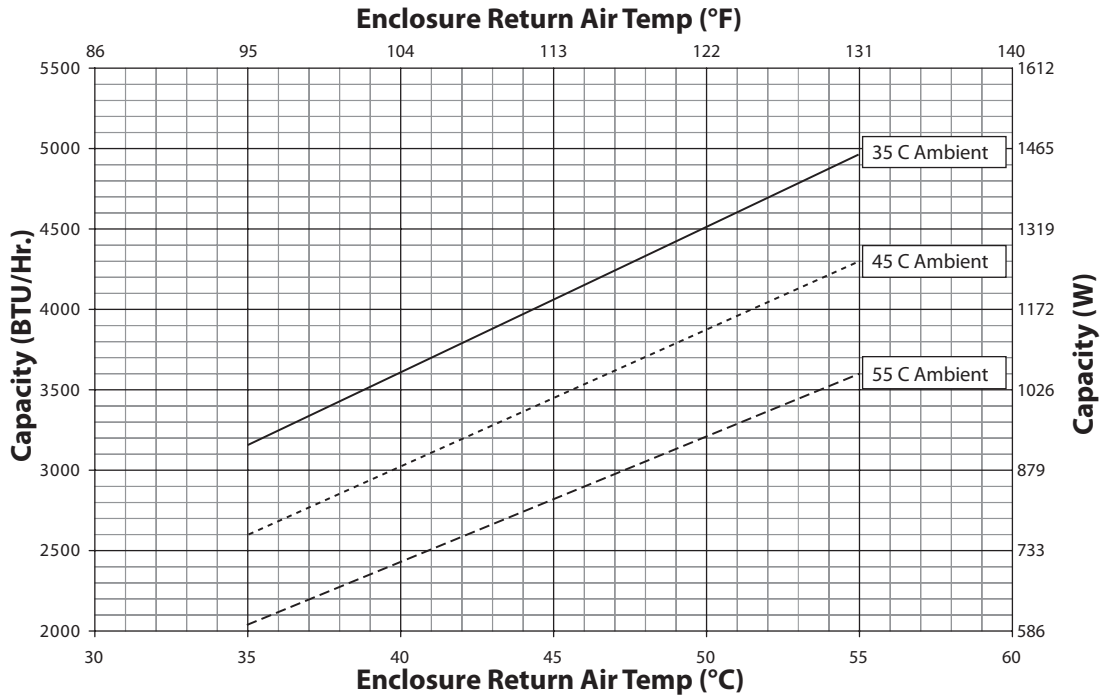

T29-04x6-Gxx Capacity Curves 60 Hz

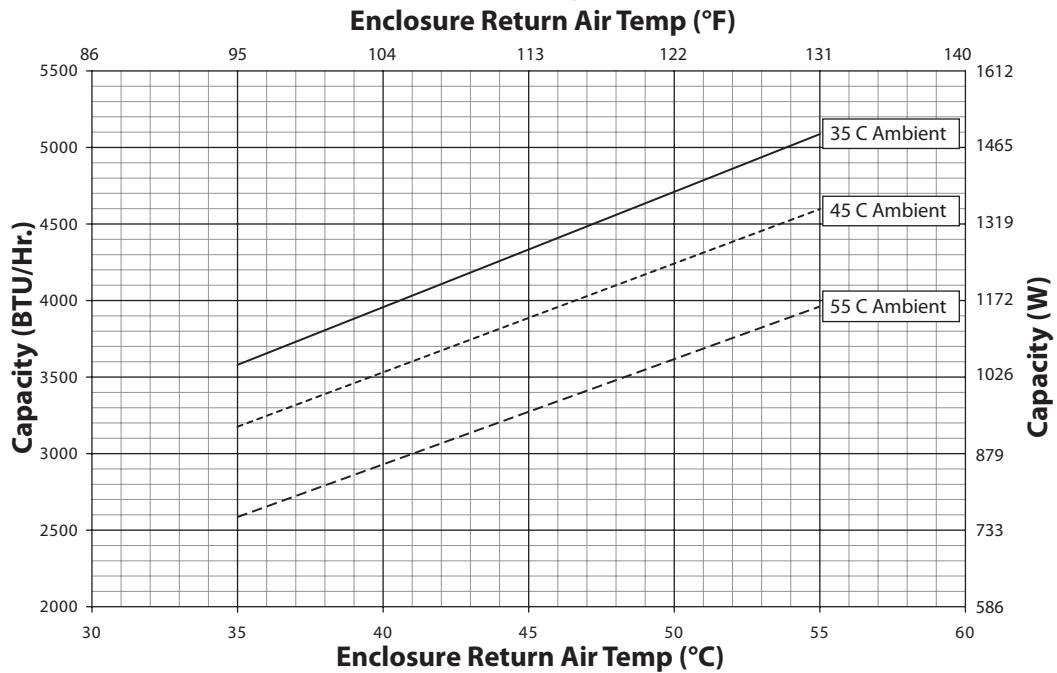

T-Series A/C

T-Series

T29 Models 4000 BTU/Hr. (1173 Watt)

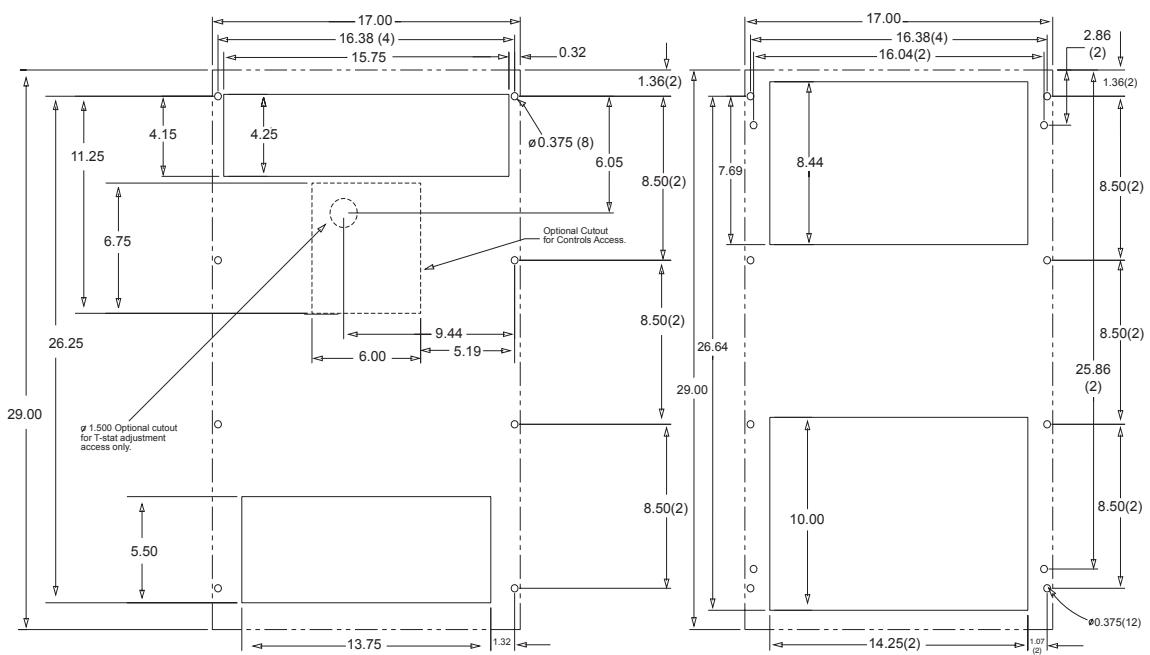
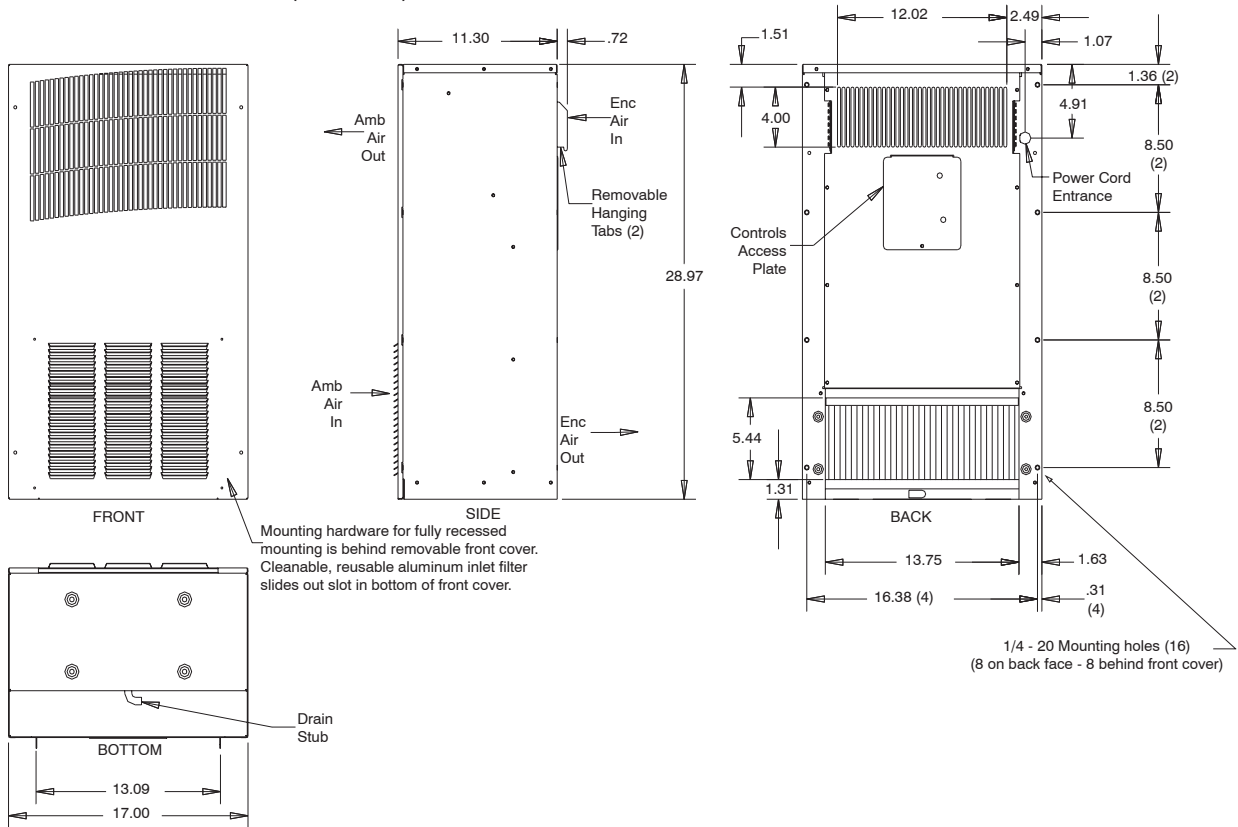

Notes:
1. Dashed lines represent air conditioner.

Externally Mounted

CUTOUT INSTRUCTIONS
(as viewed from outside enclosure)

Internally Mounted

89043917

Visit www.McLeanCoolingTech.com to download 2D and 3D CAD drawings into the overall design of your electronic system.

T-Series

Performance Data T43 6000 BTU/Hr. (1758 Watt) Models

CATALOG NUMBER	T430616G150	T430626G150	T430646G400
COOLING PERFORMANCE			
Nominal:			
BTUs/Hr.	6310/6680	6520/6770	6520/6770
Watts	1848/1958	1910/1985	1910/1985
At 131 F/131 F (55 C/55 C):			
BTUs/Hr. (50/60 Hz)	6400/6680	6520/6774	6520/6774
W (50/60 Hz)	1875/1957	1910/1985	1910/1985
At 95 F/95 F (35 C/35 C):			
BTUs/Hr. (50 /60 Hz)	5500/5900	5461/5846	5461/5846
W (50/60 Hz)	1611/1729	1600/1713	1600/1713
Refrigerant	R-134A	R-134A	R-134A
Refrigerant Charge (ounces/grams)	30/850	30/850	30/850
Operating Temperature Range:			
Maximum (°F/°C)	131/55	131/55	131/55
Minimum (°F/°C)	-40/-40	-40/-40	-40/-40
Airflow at 0 Static Pressure:			
Internal loop 50 Hz (CFM/m ³ /hr.)	310/527	310/527	310/527
External loop 50 Hz (CFM/m ³ /hr.)	345/586	345/586	345/586
Internal loop 60 Hz (CFM/m ³ /hr.)	320/544	320/544	320/544
External loop 60 Hz (CFM/m ³ /hr.)	355/603	355/603	355/603
Max. Heater W (Outdoor Models)	1000	1000	N/A
ELECTRICAL DATA			
Rated Voltage	115	230	460V 1PH
Frequency (Hz)	50/60	50/60	50/60
Operating Range	+/- 10%	+/- 10%	+/- 10%
Max. Power Consumption (W at 50/60 Hz)	1058/989	1012/874	1104/966
Max. Nominal Current (A at 50/60 Hz)	9.2/8.6	4.4/3.8	2.4/2.1
Starting Current (A)	57.2	27	14
Agency Approvals		cUL Listed CE	cUR Recognized CE
	Others available upon request		
Power Input Description	6-ft. cord with NEMA 5-20 plug	6-ft. cord with NEMA 6-15 plug	6-ft. cord with wire leads
ENCLOSURE PROTECTION			
UL Type	Type 12/3R/4 standard 4X Stainless steel optional		
International Rating	IP56 on the internal loop; IP34 on the external loop		
CONTROLLER			
Description	Basic mechanical thermostat		
Thermostat Location	Enclosure side on all base models		
Factory Thermostat Setting (°F/°C)	80/27		
SOUND LEVEL			
At 1.5 M	65.7 dB(A)		
UNIT CONSTRUCTION			
Material	Galvanized sheet metal standard Stainless steel optional		
Finish	RAL 7035 light-gray, semi-textured powder-coat paint standard		
UNIT DIMENSIONS			
Height (in./mm)	43/1092		
Width (in./mm)	15.75/400		
Depth (in./mm)	10.9/279		
Weight (lb./kg)	125/57		

T-Series

Performance Curves for T43 Models 6000 BTU/Hr. (1758 Watt)

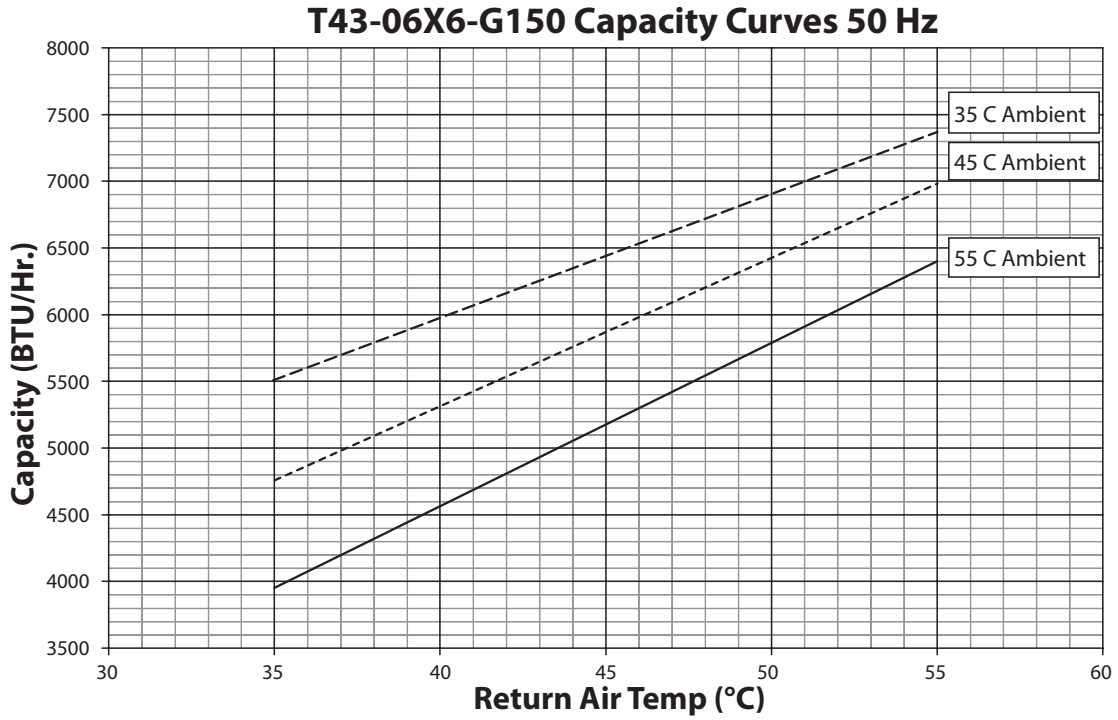

T-Series A/C

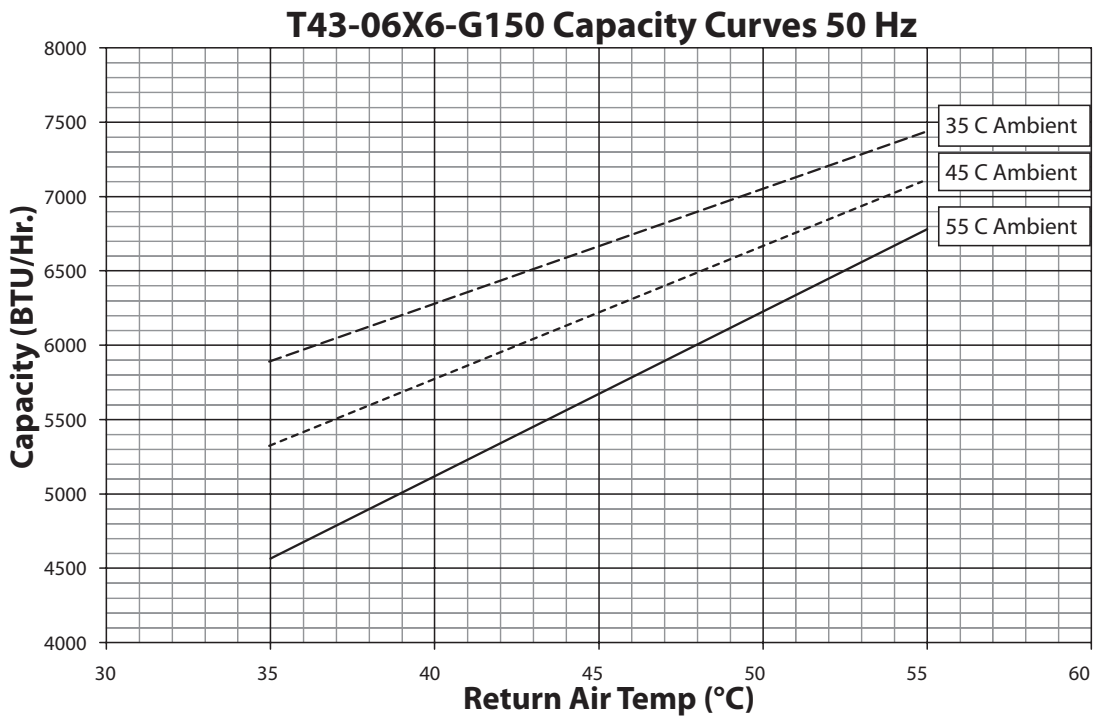

T-Series

Performance Data T43 8000 BTU/Hr. (2344 W) Models

CATALOG NUMBER	T430816G150	T430826G150	T430846G400
COOLING PERFORMANCE			
Nominal:			
BTUs/Hr.	7900/8600	7400/8200	7400/8200
Watts	2310/2500	2160/2400	2160/2400
At 131 F/131 F (55 C/55 C):			
BTUs/Hr. (50/60 Hz)	7937/8629	7484/8215	7484/8215
W (50/60 Hz)	2326/2528	2193/2407	2193/2407
At 95 F/95 F (35 C/35 C):			
BTUs/Hr. (50 /60 Hz)	6401/7100	5940/6705	5940/6705
W (50/60 Hz)	1875/2080	1740/1965	1740/1965
Refrigerant	R-134A	R-134A	R-134A
Refrigerant Charge (ounces/grams)	36/1022	36/1022	36/1022
Operating Temperature Range:			
Maximum (°F/°C)	131/55	131/55	131/55
Minimum (°F/°C)	-40/-40	-40/-40	-40/-40
Airflow at 0 Static Pressure:			
Internal loop 50 Hz (CFM/m ³ /hr.)	273/464	273/464	273/464
External loop 50 Hz (CFM/m ³ /hr.)	310/527	310/527	310/527
Internal loop 60 Hz (CFM/m ³ /hr.)	290/493	290/493	290/493
External loop 60 Hz (CFM/m ³ /hr.)	315/535	315/535	315/535
Max. Heater W (Outdoor Models)	1000	1000	N/A
ELECTRICAL DATA			
Rated Voltage	115	230	460V 1PH
Frequency (Hz)	50/60	50/60	50/60
Operating Range	+/- 10%	+/- 10%	+/- 10%
Max. Power Consumption (W at 50/60 Hz)	1196/1288	1196/1242	1334/1380
Max. Nominal Current (A at 50/60 Hz)	10.4/11.2	5.2/5.4	2.9/3.0
Starting Current (A)	48.3	27	14
Agency Approvals		cUL Listed CE	cUR Recognized CE
	Others available upon request		
Power Input Description	6-ft. cord with NEMA 5-20 plug	6-ft. cord with NEMA 6-15 plug	6-ft. cord with wire leads
ENCLOSURE PROTECTION			
UL Type	Type 12/3R/4 standard 4X Stainless steel optional		
International Rating	IP56 on the internal loop; IP34 on the external loop		
CONTROLLER			
Description	Basic mechanical thermostat		
Thermostat Location	Enclosure side on all base models		
Factory Thermostat Setting (°F/°C)	80/27		
SOUND LEVEL			
At 1.5 M	65.7 dB(A)		
UNIT CONSTRUCTION			
Material	Galvanized sheet metal standard Stainless steel optional		
Finish	RAL 7035 light-gray, semi-textured powder-coat paint standard		
UNIT DIMENSIONS			
Height (in./mm)	43/1092		
Width (in./mm)	15.75/400		
Depth (in./mm)	10.9/279		
Weight (lb./kg)	125/57		

T-Series A/C

T-Series

Performance Curves for T43 Models 8000 BTU/Hr. (2344 Watt)

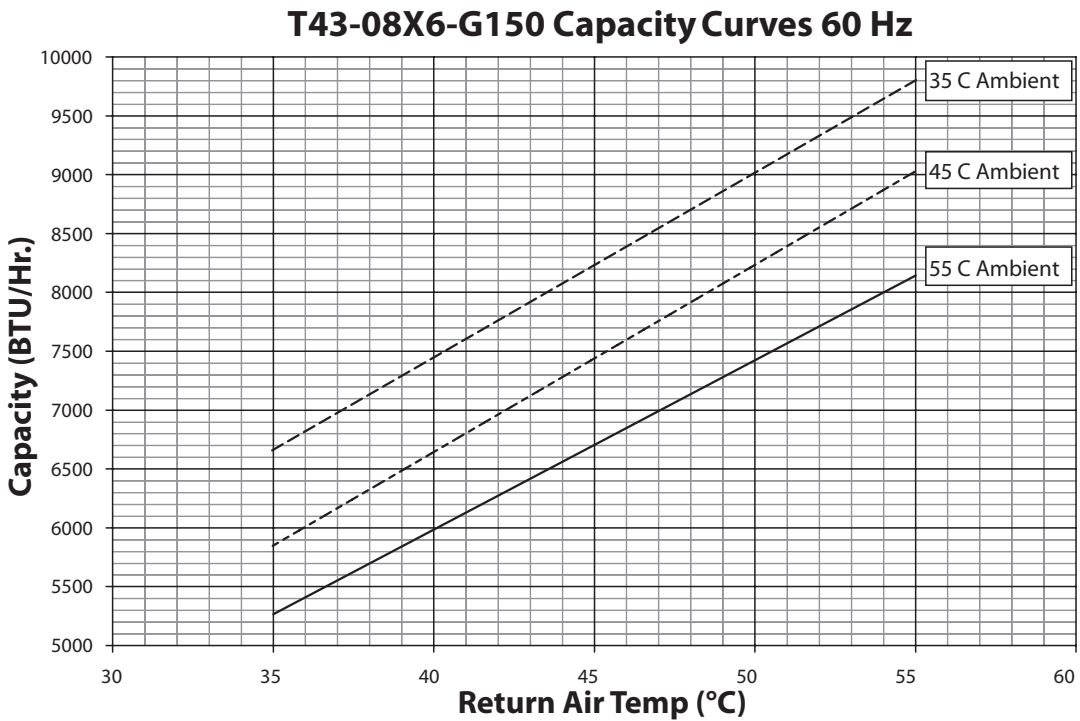
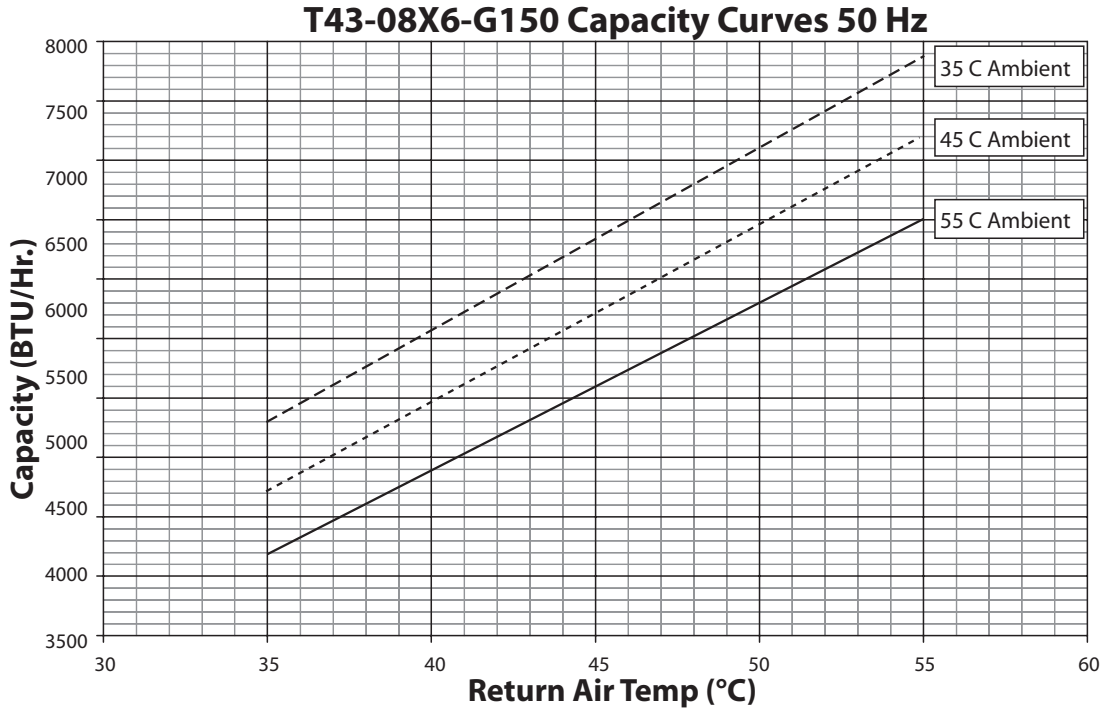

T-Series A/C

T-Series

Performance Data T43 10000 BTU/Hr. (2930 W) Models

CATALOG NUMBER			
	T431016G150	T431026G150	T431046G400
COOLING PERFORMANCE			
Nominal:			
BTUs/Hr.	9670/10300	10100/10500	10100/10500
Watts	2831/3016	2957/3075	2957/3075
At 131 F/131 F (55 C/55 C):			
BTUs/Hr. (50/60 Hz)	9667/10290	10039/10669	10039/10669
W (50/60 Hz)	2832/3015	2941/3126	2941/3126
At 95 F/95 F (35 C/35 C):			
BTUs/Hr. (50/60 Hz)	7663/8397	8458/8837	8458/8837
W (50/60 Hz)	2245/2460	2478/2589	2478/2589
Refrigerant	R-134A	R-134A	R-134A
Refrigerant Charge (ounces/grams)	32/907	32/907	32/907
Operating Temperature Range:			
Maximum (°F/°C)	131/55	131/55	131/55
Minimum (°F/°C)	-40/-40	-40/-40	-40/-40
Airflow at 0 Static Pressure:			
Internal loop 50 Hz (CFM/m ³ /hr.)	272/462	320/544	320/544
External loop 50 Hz (CFM/m ³ /hr.)	510/866	568/965	568/965
Internal loop 60 Hz (CFM/m ³ /hr.)	290/493	330/561	330/561
External loop 60 Hz (CFM/m ³ /hr.)	565/960	636/1081	636/1081
Max. Heater W (Outdoor Models)	1000	1000	N/A
ELECTRICAL DATA			
Rated Voltage	115	230	460V 1PH
Frequency (Hz)	50/60	50/60	50/60
Operating Range	+/- 10%	+/- 10%	+/- 10%
Max. Power Consumption (W at 50/60 Hz)	1828.5/2288.5	2070	1334/1380
Max. Nominal Current (A at 50/60 Hz)	15.9/19.9	9	5
Starting Current (A)	57	38	20
Agency Approvals		cUL Listed CE	cUR Recognized CE
Others available upon request			
Power Input Description	6-ft. cord with NEMA 5-30 plug	6-ft. cord with NEMA 6-15 plug	6-ft. cord with wire leads
ENCLOSURE PROTECTION			
UL Type	Type 12/3R/4 standard 4X Stainless steel optional		
International Rating	IP56 on the internal loop; IP34 on the external loop		
CONTROLLER			
Description	Basic mechanical thermostat		
Thermostat Location	Enclosure side on all base models		
Factory Thermostat Setting (°F/°C)	80/27		
SOUND LEVEL			
At 1.5 M	73.3 dB(A)		
UNIT CONSTRUCTION			
Material	Galvanized sheet metal standard Stainless steel optional		
Finish	RAL 7035 light-gray, semi-textured powder-coat paint standard		
UNIT DIMENSIONS			
Height (in./mm)	43/1092		
Width (in./mm)	15.75/400		
Depth (in./mm)	10.9/279		
Weight (lb./kg)	125/57		

T-Series

Performance Curves for T43 Models 10000 BTU/Hr. (2930 Watt)

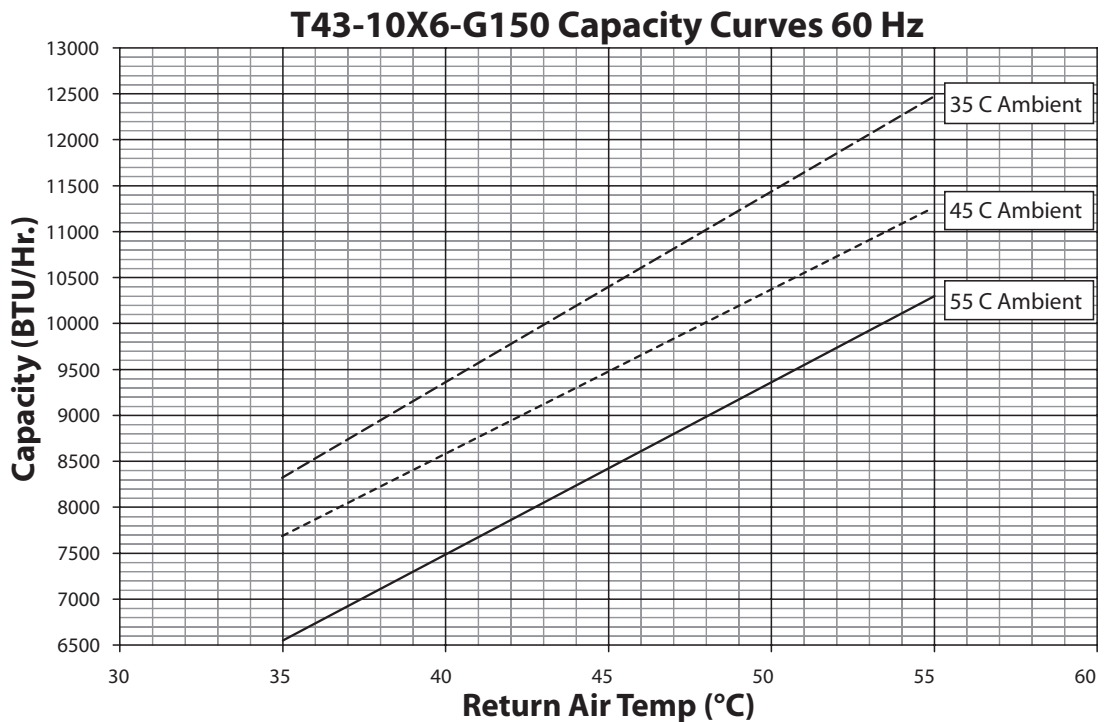
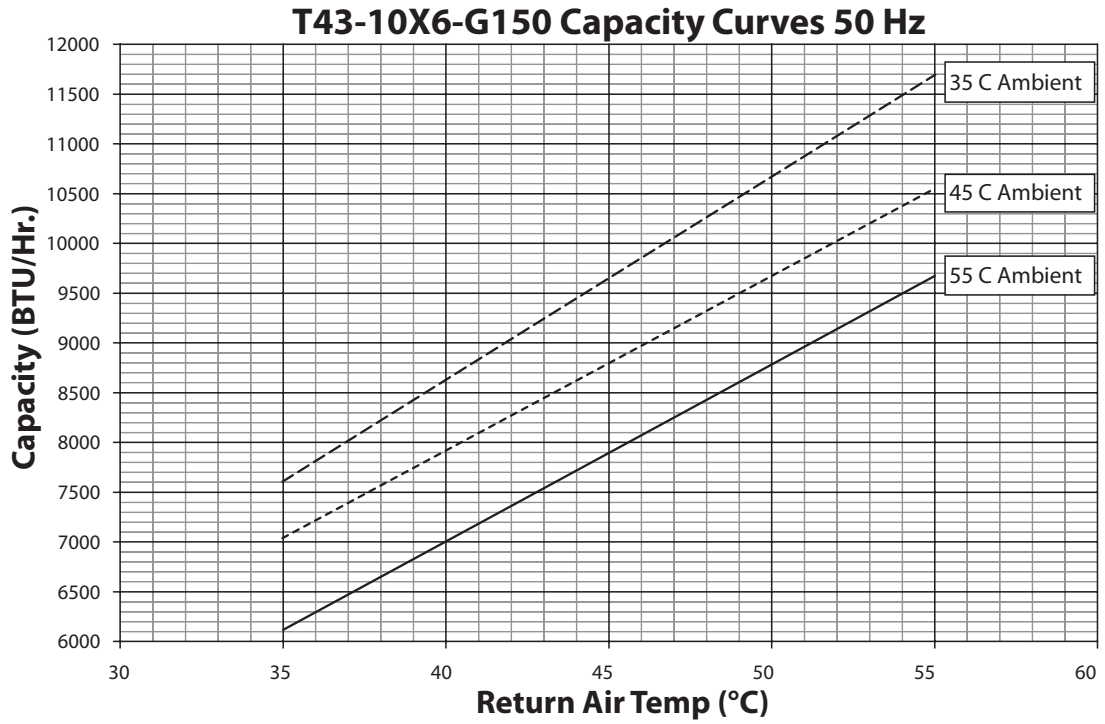

T-Series A/C

T-Series

T43 6000 - 10000 Models BTU/Hr. (1758 - 2930 Watt)

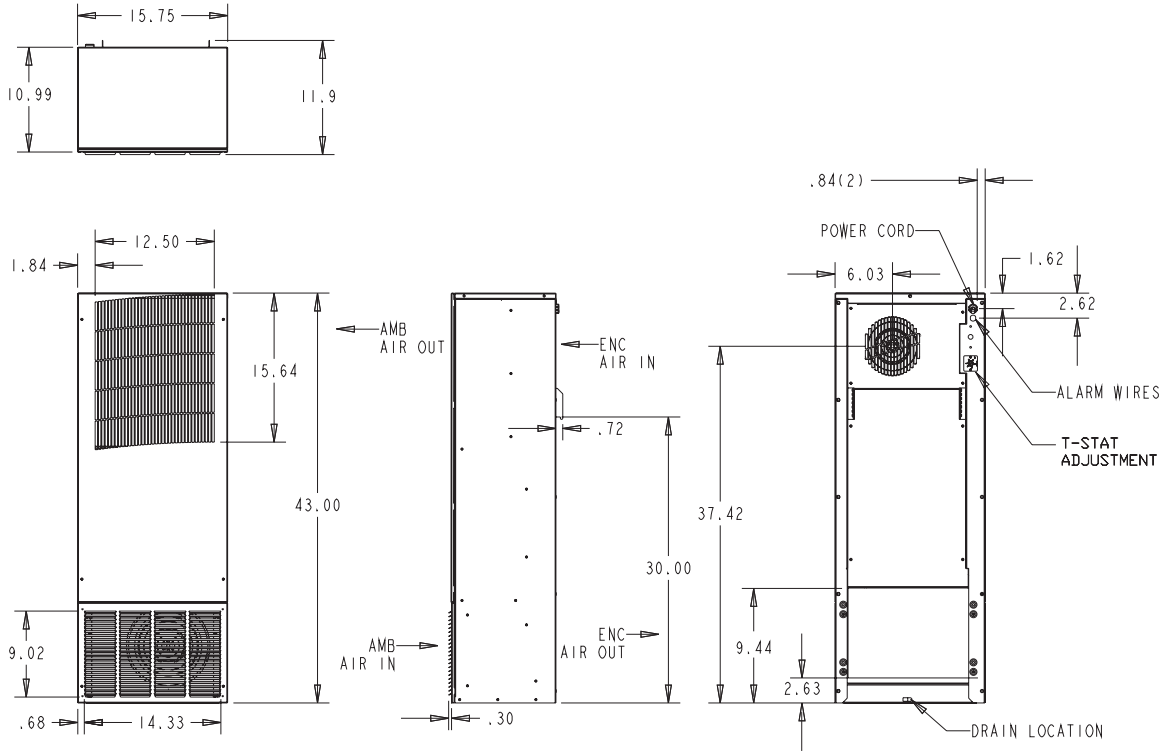

T-Series A/C

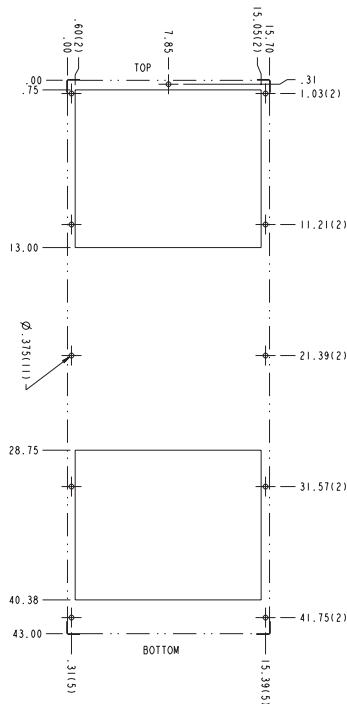

Externally Mounted

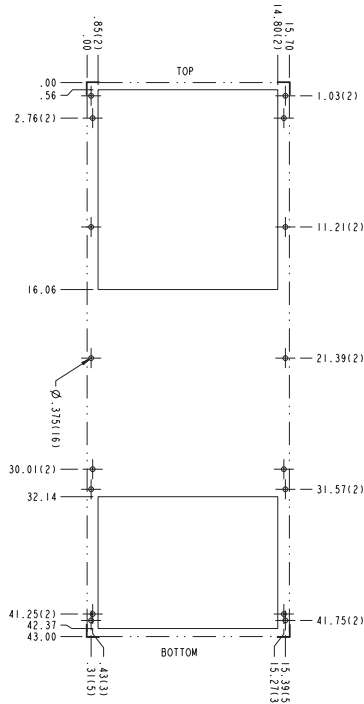

Internally Mounted

89043918

Visit www.McLeanCoolingTech.com to download 2D and 3D CAD drawings into the overall design of your electronic system.

T-Series

Performance Data T50 12000 BTU/Hr. (3516 W) Models

CATALOG NUMBER		
	T501226G150	T501246G400
COOLING PERFORMANCE		
Nominal:		
BTUs/Hr.	11000/12000	11000/12000
Watts	3223/3516	3223/3516
At 131 F/131 F (55 C/55 C):		
BTUs/Hr. (50/60 Hz)	10030/12000	10030/12000
W (50/60 Hz)	2939/3516	2939/3516
At 95 F/95 F (35 C/35 C):		
BTUs/Hr. (50 /60 Hz)	9300/10050	9300/10050
W (50/60 Hz)	2725/2945	2725/2945
Refrigerant	R-134A	R-134A
Refrigerant Charge (ounces/grams)	46/1300	46/1300
Operating Temperature Range:		
Maximum (°F/°C)	131/55	131/55
Minimum (°F/°C)	-40/-40	-40/-40
Airflow at 0 Static Pressure:		
Internal loop 50 Hz (CFM/m ³ /hr.)	300/510	300/510
External loop 50 Hz (CFM/m ³ /hr.)	520/883	520/883
Internal loop 60 Hz (CFM/m ³ /hr.)	368/626	368/626
External loop 60 Hz (CFM/m ³ /hr.)	625/1062	625/1062
Max. Heater W (Outdoor Models)	1500	1500
ELECTRICAL DATA		
Rated Voltage	220/230	460V 1PH
Frequency (Hz)	50/60	50/60
Operating Range	+/- 10%	+/- 10%
Max. Power Consumption (W at 50/60 Hz)	1804/2139	2070/2346
Max. Nominal Current (A at 50/60 Hz)	8.2/9.3	4.5/5.1
Starting Current (A)	38	20
Agency Approvals	cUL Listed	cUR Recognized
	CE	CE
Power Input Description	6-ft. cord with NEMA 6-15 plug	6-ft. cord with wire leads
ENCLOSURE PROTECTION		
UL Type	Type 12/3R/4 standard 4X Stainless steel optional	
CONTROLLER		
Description	Basic mechanical thermostat	
Thermostat Location	Enclosure side on all base models	
Factory Thermostat Setting (°F/°C)	80/27	
SOUND LEVEL		
At 1.5 M	68 dB(A)	
UNIT CONSTRUCTION		
Material	Galvanized sheet metal standard Stainless steel optional	
Finish	RAL 7035 light-gray, semi-textured powder-coat paint standard	
UNIT DIMENSIONS		
Height (in./mm)	50/1270	50/1270
Width (in./mm)	19/483	19/483
Depth (in./mm)	11.05/281	11.05/281
Weight (lb./kg)	164/75	164/75

T-Series A/C

T-Series

Performance Curves for T50 Models 12000 BTU/Hr. (3516 Watt)

T50-12x6-GXXX Capacity Curves 50 Hz

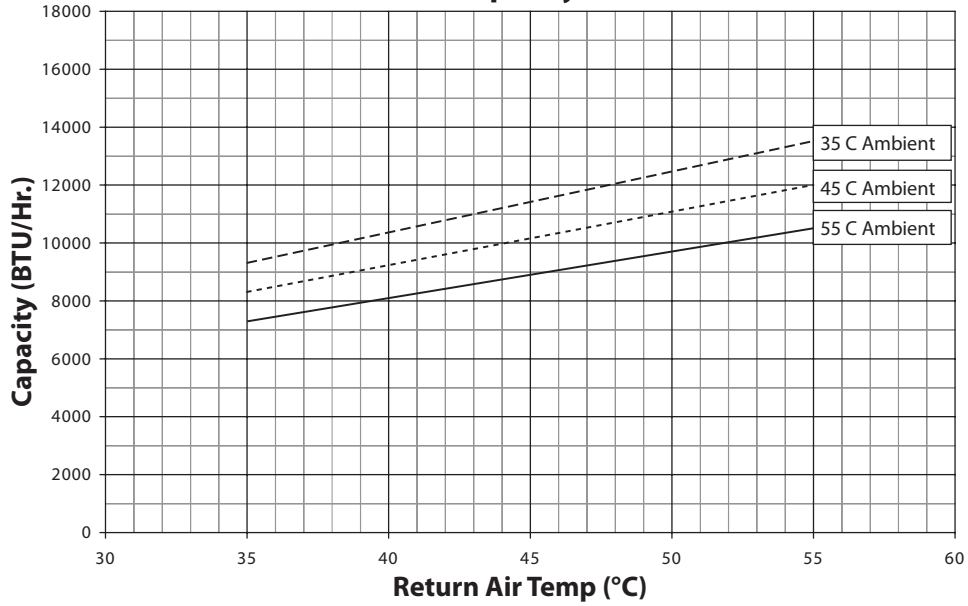

T50-12x6-GXXX Capacity Curves 60 Hz

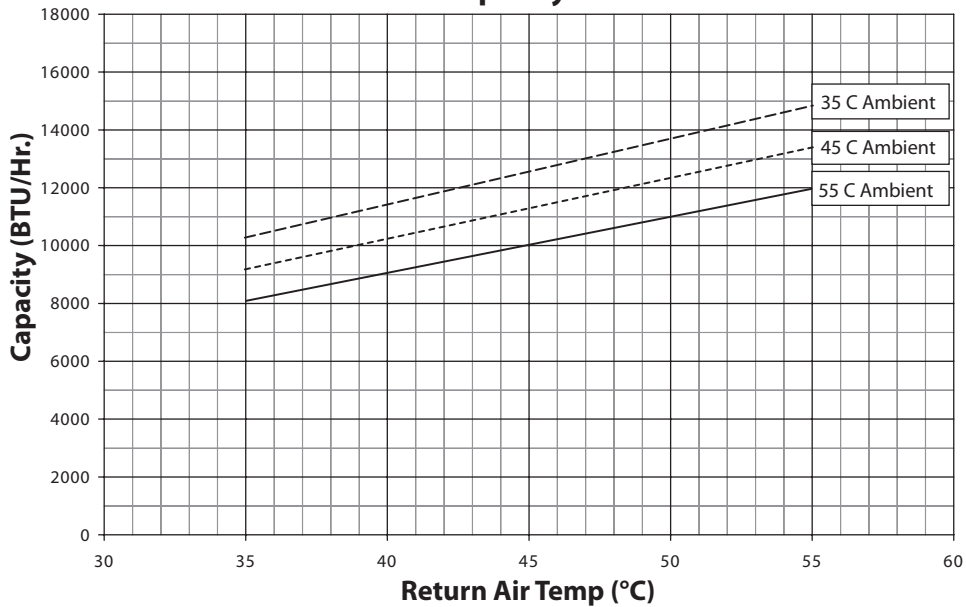

T-Series

T50 Models 12000 BTU/Hr. (3516 Watt)

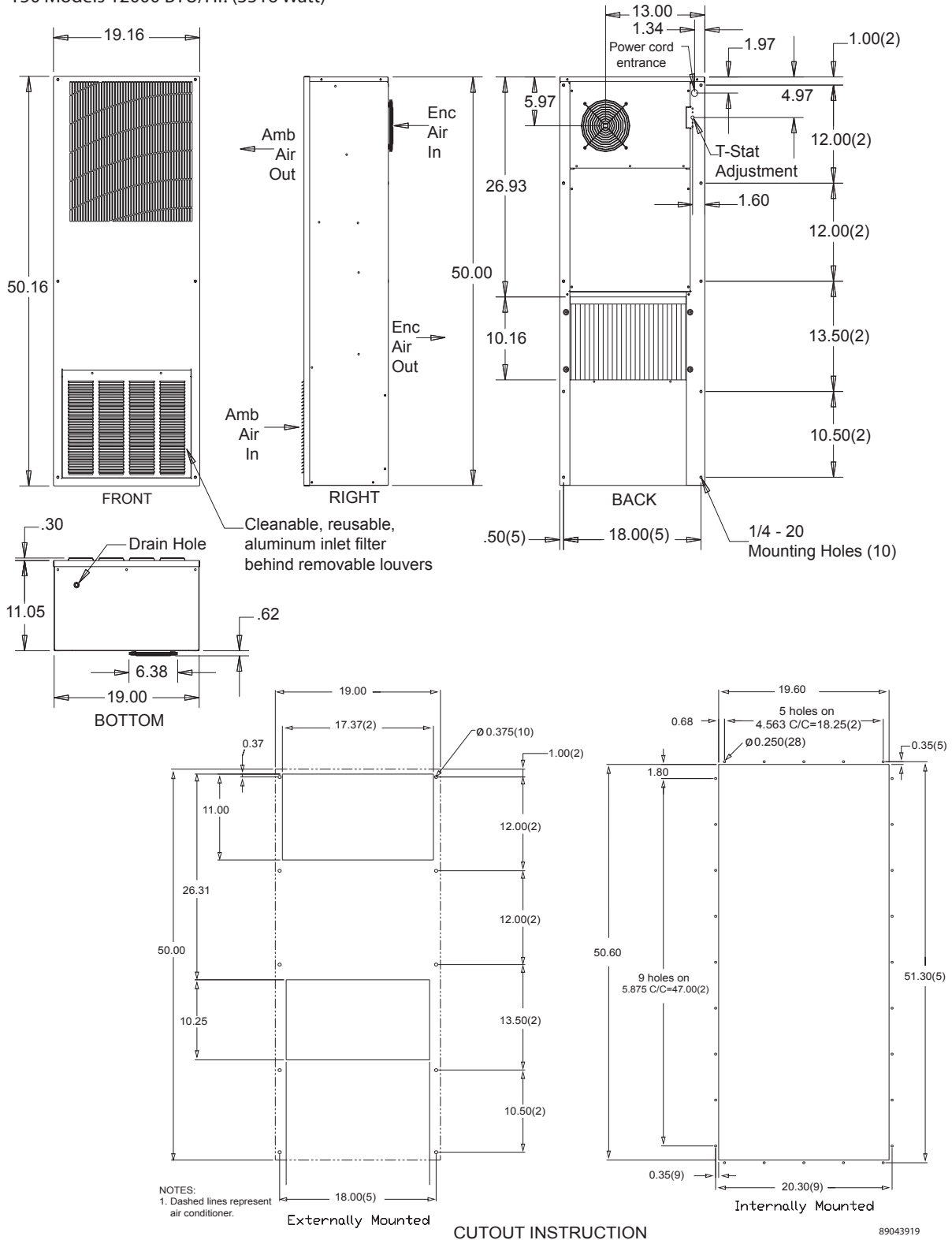

T-Series A/C

Visit www.McLeanCoolingTech.com to download 2D and 3D CAD drawings into the overall design of your electronic system.

T-Series

Performance Data T53 19000 BTU/Hr. (5567 W) Models

CATALOG NUMBER		
	T531926G150	T531946G400
COOLING PERFORMANCE		
Nominal:		
BTUs/Hr.	16800/19000	16800/19000
Watts	4922/5567	4922/5567
At 131 F/131 F (55 C/55 C):		
BTUs/Hr. (50/60 Hz)	16854/19081	4939/5592
W (50/60 Hz)	4939/5592	4939/5592
At 95 F/95 F (35 C/35 C):		
BTUs/Hr. (50 /60 Hz)	15240/19815	15240/19815
W (50/60 Hz)	4466/5807	4466/5807
Refrigerant	410A	410A
Refrigerant Charge (ounces/grams)	40/1132	40/1132
Operating Temperature Range:		
Maximum (°F/°C)	131/55	131/55
Minimum (°F/°C)	-40/-40	-40/-40
Airflow at 0 Static Pressure:		
Internal loop 50 Hz (CFM/m ³ /hr.)	449/763	449/763
External loop 50 Hz (CFM/m ³ /hr.)	1204/2046	1204/2046
Internal loop 60 Hz (CFM/m ³ /hr.)	519/882	519/882
External loop 60 Hz (CFM/m ³ /hr.)	1300/2209	1300/2209
Max. Heater W (Outdoor Models)	3000	
ELECTRICAL DATA		
Rated Voltage	230	460V 1PH
Frequency (Hz)	50/60	50/60
Operating Range	+/- 10%	+/- 10%
Max. Power Consumption (W at 50/60 Hz)	3979/4669	4370/5152
Max. Nominal Current (A at 50/60 Hz)	17.3/20.3	9.5/11.2
Starting Current (A)	54	28
Agency Approvals	cUL Listed	cUR Recognized
Power Input Description	CE	Terminal block CE
ENCLOSURE PROTECTION		
UL Type	Type 12/3R/4 standard 4X Stainless steel optional	
CONTROLLER		
Description	Basic mechanical thermostat	
Thermostat Location	Enclosure side on all base models	
Factory Thermostat Setting (°F/°C)	80/27	
SOUND LEVEL		
At 1.5 M	76 dB(A)	
UNIT CONSTRUCTION		
Material	Galvanized sheet metal standard Stainless steel optional	
Finish	RAL 7035 light-gray, semi-textured powder-coat paint standard	
UNIT DIMENSIONS		
Height (in./mm)	53.0/1346.2	
Width (in./mm)	21.0/533.4	
Depth (in./mm)	13.0/330.2	
Weight (lb./kg)	197/90	237/108

T-Series

Performance Curves for T53 Models 19000 BTU/Hr. (5567 Watt)

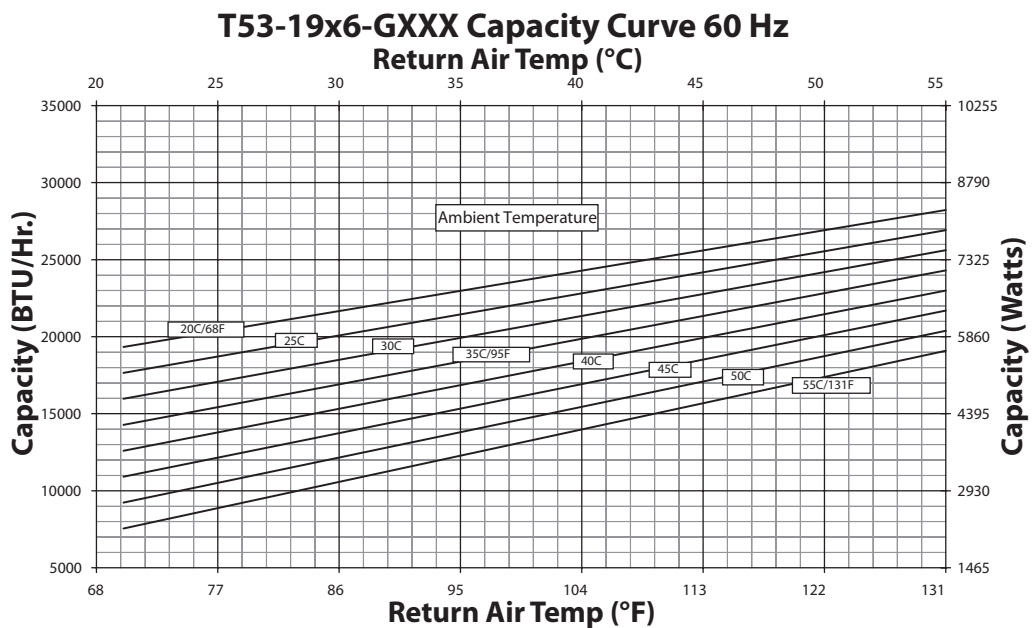
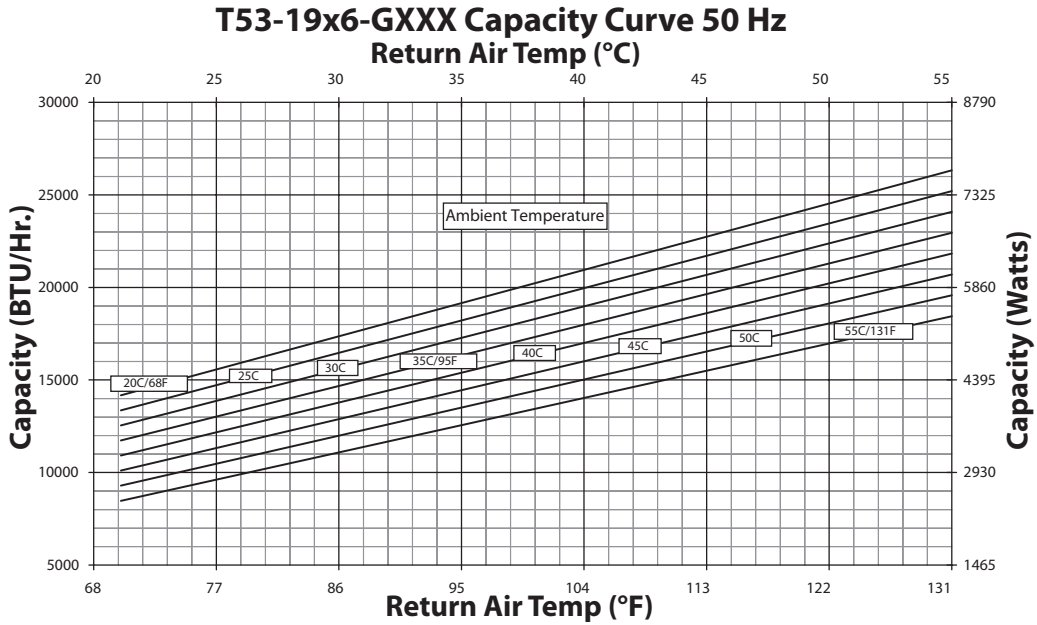

T-Series A/C

T-Series

T53 Models 19000 BTU/Hr. (5567 Watt)

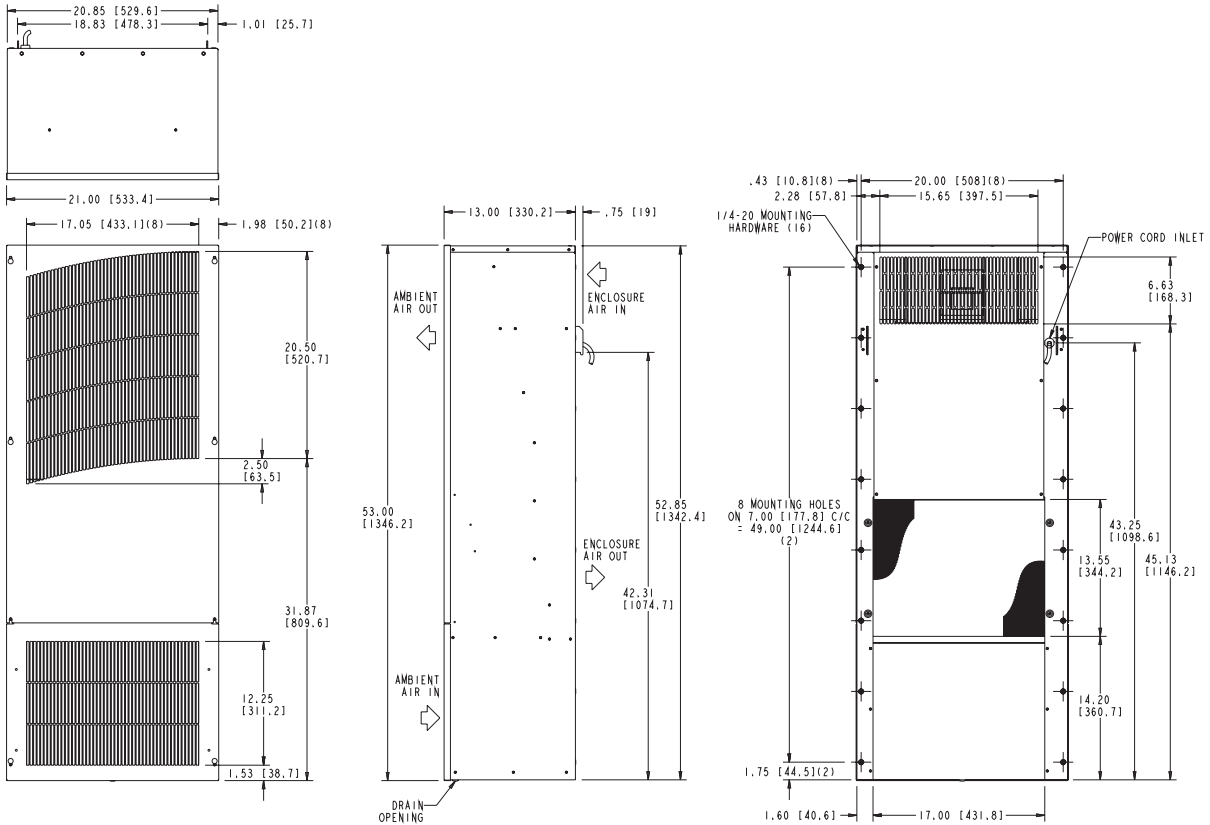

T-Series A/C

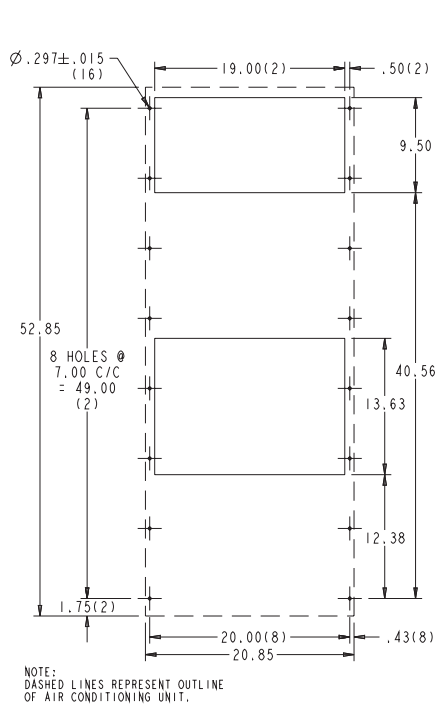

Externally Mounted

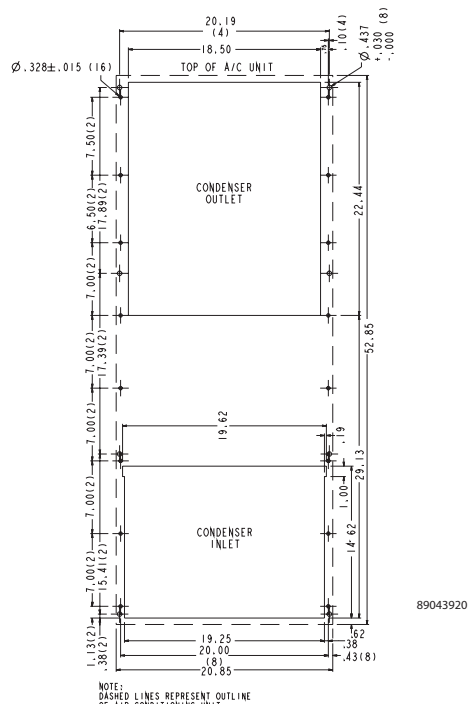

Internally Mounted

Cutout Instruction

Visit www.McLeanCoolingTech.com to download 2D and 3D CAD drawings into the overall design of your electronic system.

T-Series

Performance Data T62 20000 BTU/Hr. (5860 W) Models

CATALOG NUMBER		
	T622226G150	T622246G400
COOLING PERFORMANCE		
Nominal:		
BTUs/Hr.	20500/23500	20500/23500
Watts	6007/6886	6007/6886
At 131 F/131 F (55 C/55 C):		
BTUs/Hr. (50/60 Hz)	20860/23927	6113/7012
W (50/60 Hz)	6113/7012	6113/7012
At 95 F/95 F (35 C/35 C):		
BTUs/Hr. (50 /60 Hz)	18258/20256	18258/20256
W (50/60 Hz)	5351/5936	5351/5936
Refrigerant	R-407C	R-407C
Refrigerant Charge (ounces/grams)	42/1300	42/1300
Operating Temperature Range:		
Maximum (°F/°C)	131/55	131/55
Minimum (°F/°C)	-40/-40	-40/-40
Airflow at 0 Static Pressure:		
Internal loop 50 Hz (CFM/m ³ /hr.)	570/968	570/968
External loop 50 Hz (CFM/m ³ /hr.)	1443/2452	1443/2452
Internal loop 60 Hz (CFM/m ³ /hr.)	673/1143	673/1143
External loop 60 Hz (CFM/m ³ /hr.)	1797/3053	1797/3053
Max. Heater W (Outdoor Models)	2000	Up to 3000 (Optional)
ELECTRICAL DATA		
Rated Voltage	230	460V 1PH
Frequency (Hz)	50/60	50/60
Operating Range	+/- 10%	+/- 10%
Max. Power Consumption (W at 50/60 Hz)	4370/5060	7000/9200
Max. Nominal Current (A at 50/60 Hz)	19/22	10.5/12
Starting Current (A)	60	30
Agency Approvals	cUL Listed CE	cUR Recognized CE
Power Input Description	Terminal block	Terminal block
ENCLOSURE PROTECTION		
UL Type	Type 12/3R/4 standard 4X Stainless steel optional	
CONTROLLER		
Description	Basic mechanical thermostat	
Thermostat Location	Enclosure ide on all base models	
Factory Thermostat Setting (°F/°C)	80/27	
SOUND LEVEL		
At 1.5 M	71 dB(A)	
UNIT CONSTRUCTION		
Material	Galvanized sheet metal standard Stainless steel optional	
Finish	RAL 7035 light-gray, semi-textured powder-coat paint standard	
UNIT DIMENSIONS		
Height (in./mm)	61.77/1568.96	61.77/1568.96
Width (in./mm)	19.91/505.71	19.91/505.71
Depth (in./mm)	17.36/440.94	17.36/440.94
Weight (lb./kg)	218/99.1	258/117

T-Series A/C

T-Series

Performance Curves for T62 Models 20000 BTU/Hr. (5860 Watt)

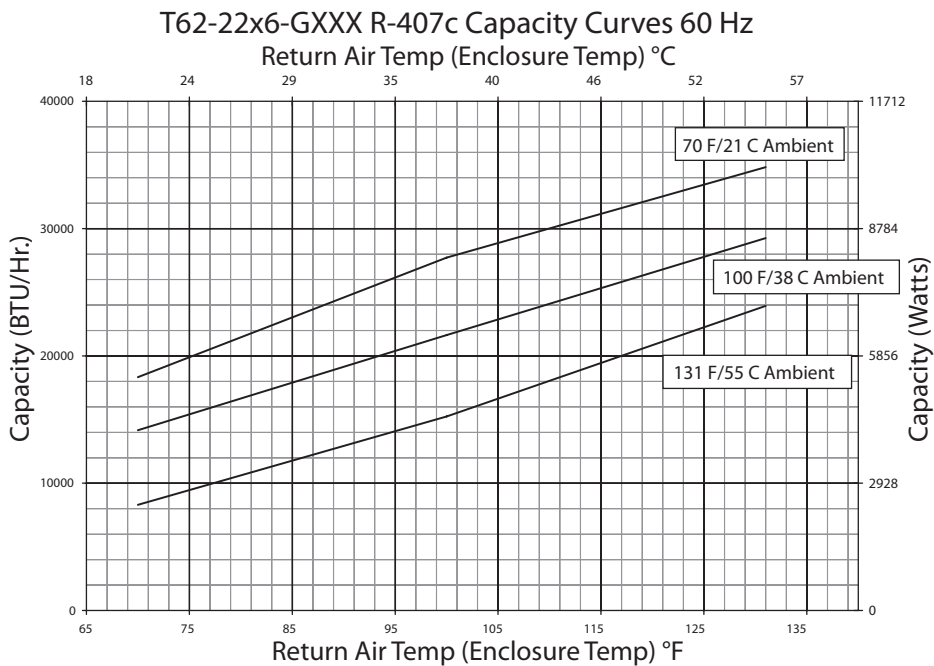
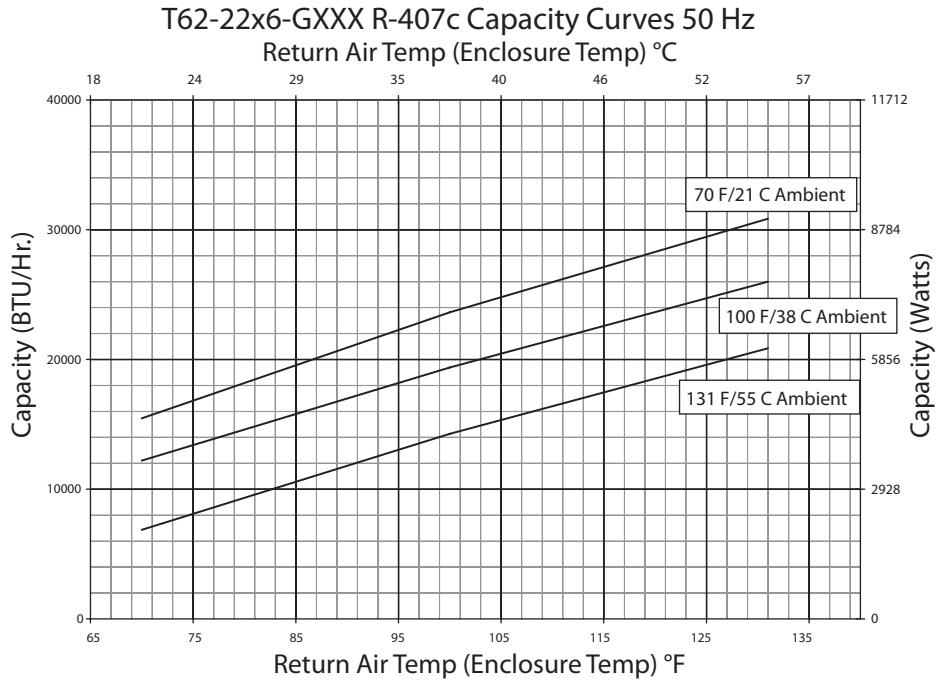

T-Series

T62 Models 20000 BTU/Hr. (5860 Watt)

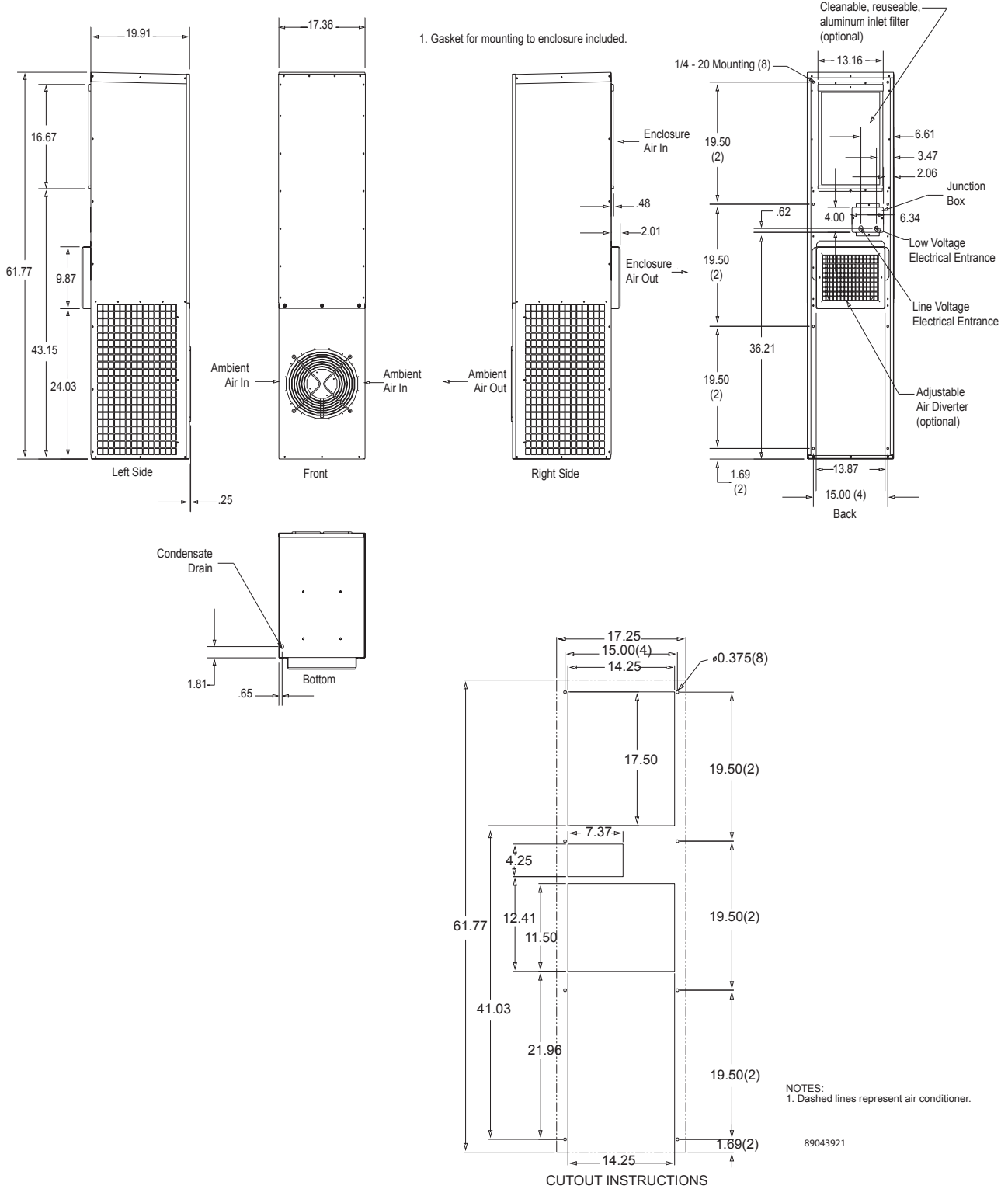

T-Series A/C

Visit www.McLeanCoolingTech.com to download 2D and 3D CAD drawings into the overall design of your electronic system.

T-Series

Performance Data T70-36 36000 BTU/Hr. (10548 W) Models

CATALOG NUMBER		T703626G150	T703646G400
COOLING PERFORMANCE			
Nominal:			
BTUs/Hr.	39000/43000		
Watts	11430/12602		
At 131 F/131 F (55 C/55 C):			
BTUs/Hr. (50/60 Hz)	38613/42930		
W (50/60 Hz)	11316/12570		
At 95 F/95 F (35 C/35 C):			
BTUs/Hr. (50 /60 Hz)	31364/36130		
W (50/60 Hz)	9192/10579		
Refrigerant	R-407C		
Refrigerant Charge (ounces/grams)	110/3118		
Operating Temperature Range:			
Maximum (°F/°C)	131/55		
Minimum (°F/°C)	-40/-40		
Airflow at 0 Static Pressure:			
Internal loop 50 Hz (CFM/m ³ /hr.)	1085/1843		
External loop 50 Hz (CFM/m ³ /hr.)	2176/3697		
Internal loop 60 Hz (CFM/m ³ /hr.)	1171/1989		
External loop 60 Hz (CFM/m ³ /hr.)	2347/3987		
Max. Heater W (Outdoor Models)	2000 Standard (5000 Optional)		
ELECTRICAL DATA			
Rated Voltage	230	460	
Frequency (Hz)	50/60	60	
Operating Range	+/- 10%	+/- 10%	
Max. Power Consumption (W at 50/60 Hz)	8280	8280	
Max. Nominal Current (A at 50/60 Hz)	36	18	
Starting Current (A)	104	52	
Agency Approvals	cUL Listed CE Others available upon request		
Power Input Description	Terminal block		
ENCLOSURE PROTECTION			
UL Type	Type 12/3R/4 standard 4X Stainless steel optional UL/cUL Listed		
International Rating	UL/cUL Listed		
CONTROLLER			
Description	Basic mechanical thermostat		
Thermostat Location	Enclosure side on all base models		
Factory Thermostat Setting (°F/°C)	80/27		
SOUND LEVEL			
At 1.5 M	66 dB(A)		
UNIT CONSTRUCTION			
Material	Galvanized sheet metal standard Stainless steel optional		
Finish	RAL 7035 light-gray, semi-textured powder-coat paint standard		
UNIT DIMENSIONS			
Height (in./mm)	69.8/1772		
Width (in./mm)	22.8/578		
Depth (in./mm)	20.94/532		

T-Series

Performance Curves for T70 Models 36000 BTU/Hr. (10548 Watt)

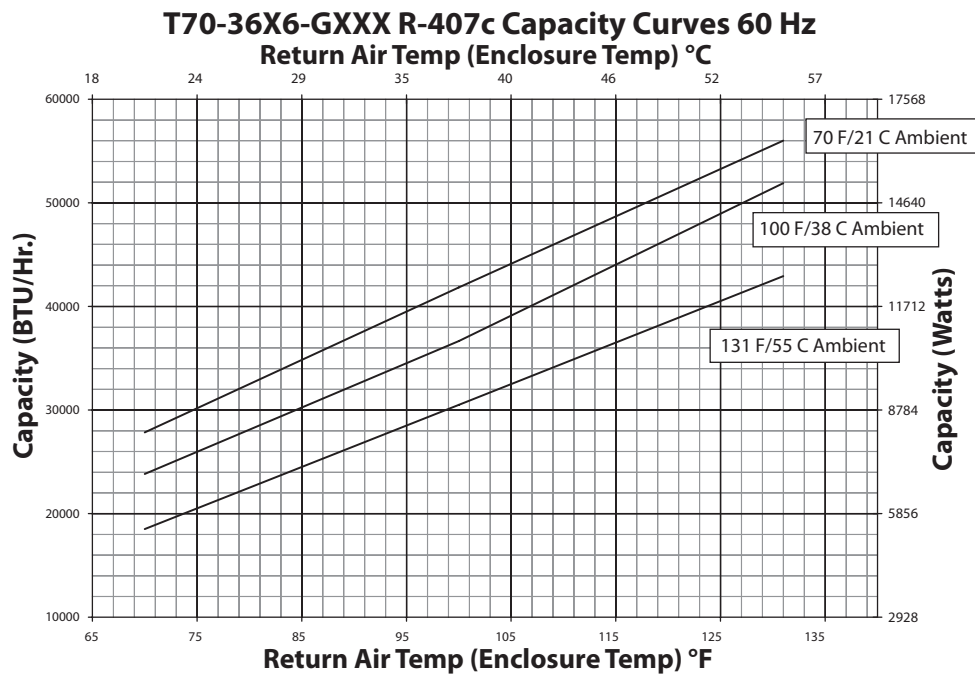
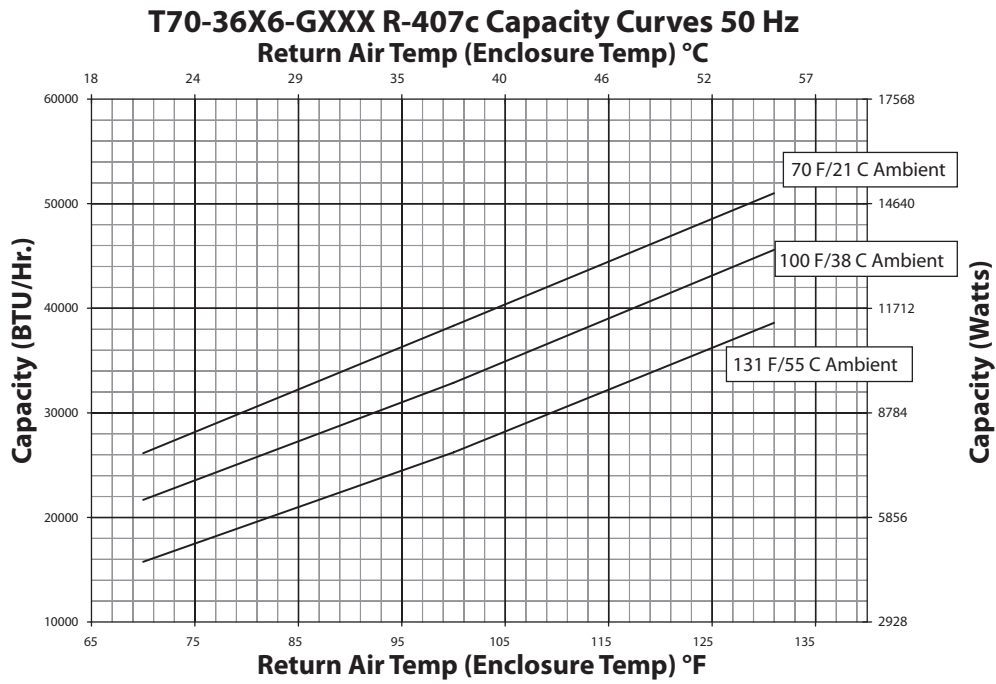

T-Series A/C

T-Series

T70 Models 36000 BTU/Hr. (10548 Watt)

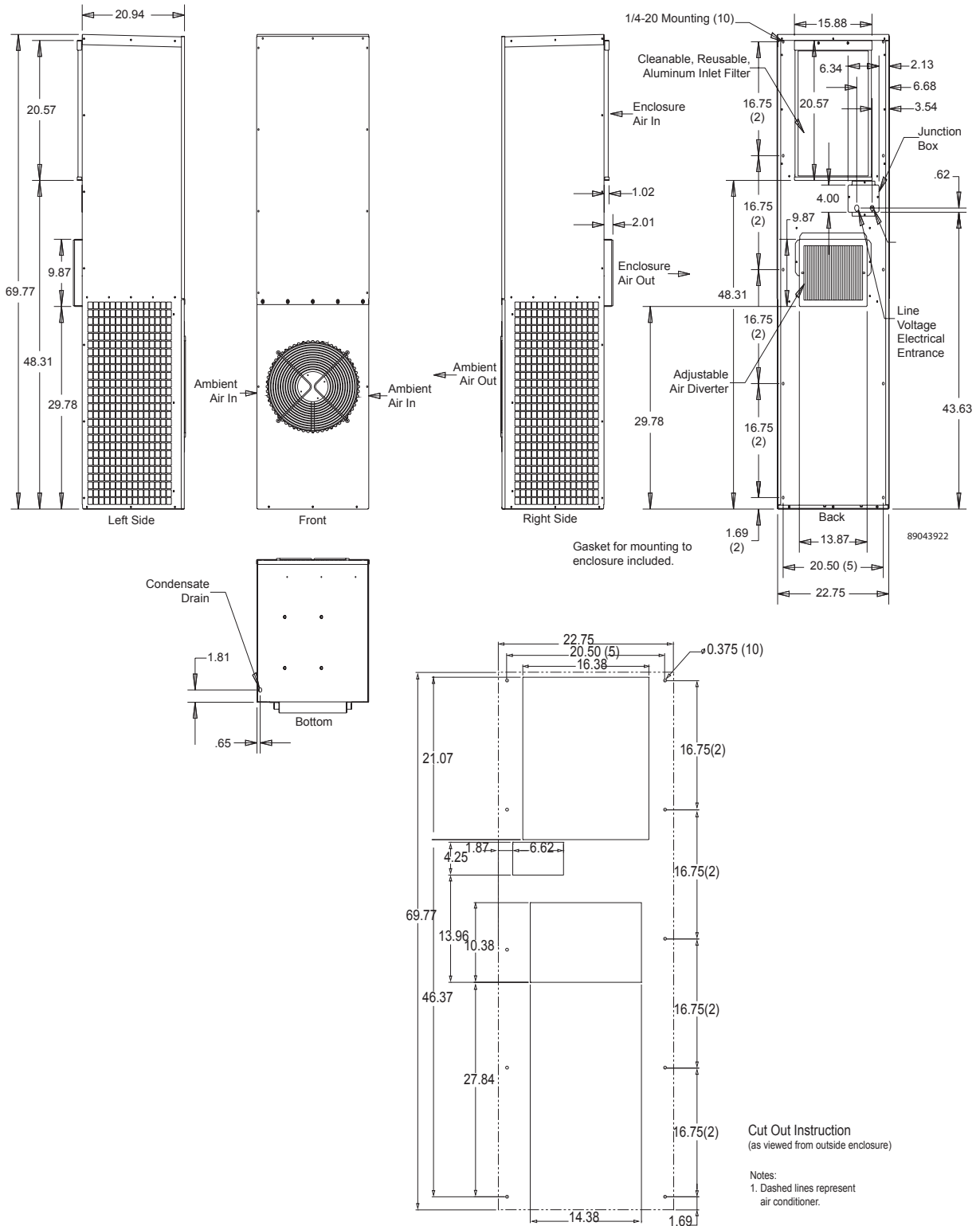

T-Series A/C

Visit www.McLeanCoolingTech.com to download 2D and 3D CAD drawings into the overall design of your electronic system.

T-Series

Performance Data T70-60 59000 BTU/Hr. (17287 W) Models

CATALOG NUMBER		
	T706026G150	T706046G400
COOLING PERFORMANCE		
Nominal:		
BTUs/Hr.	51900/60000	
Watts	15210/17584	
At 122 F/122 F (50 C/50 C):		
BTUs/Hr. (50/60 Hz)	51900/60000	
W (50/60 Hz)	15210/17584	
At 95 F/95 F (35 C/35 C):		
BTUs/Hr. (50 /60 Hz)	47122/54500	
W (50/60 Hz)	13810/15972	
Refrigerant	R-407C	
Refrigerant Charge (ounces/grams)	150/4252	
Operating Temperature Range:		
Maximum (°F/°C)	122/50	
Minimum (°F/°C)	-40/-40	
Airflow at 0 Static Pressure:		
Internal loop 50 Hz (CFM/m ³ /hr.)	1510/2565	
External loop 50 Hz (CFM/m ³ /hr.)	2716/4614	
Internal loop 60 Hz (CFM/m ³ /hr.)	1629/2767	
External loop 60 Hz (CFM/m ³ /hr.)	2931/4979	
Max. Heater W (Outdoor Models)		
ELECTRICAL DATA		
Rated Voltage	200/230	420/460
Frequency (Hz)	50/60	50/60
Operating Range	+/- 10%	+/- 10%
Max. Power Consumption (W at 50/60 Hz)	7000/9200	6426/7038
Max. Nominal Current (A at 50/60 Hz)	35/40	15.3
Starting Current (A)	144	144
Agency Approvals	cUL Listed CE Others available upon request	
Power Input Description	Terminal block	
ENCLOSURE PROTECTION		
UL Type	Type 12/3R/4 standard 4X Stainless steel optional	
International Rating	IP56 on the internal loop; IP34 on the external loop	
Description	Basic mechanical thermostat	
CONTROLLER		
Thermostat Location	Enclosure side on all base models	
Factory Thermostat Setting (°F/°C)	80/27	
SOUND LEVEL		
At 1.5 M	66 dB(A)	
UNIT CONSTRUCTION		
Material	Galvanized sheet metal standard Stainless steel optional	
Finish	RAL 7035 light-gray, semi-textured powder-coat paint standard	
UNIT DIMENSIONS		
Height (in./mm)	69.77/1772	
Width (in./mm)	35.86/911	
Depth (in./mm)	22.94/583	
Weight (lb./kg)	419/190.5	

T-Series

Performance Curves for T70 Models 59000 BTU/Hr. (17287 Watt)

T-Series A/C

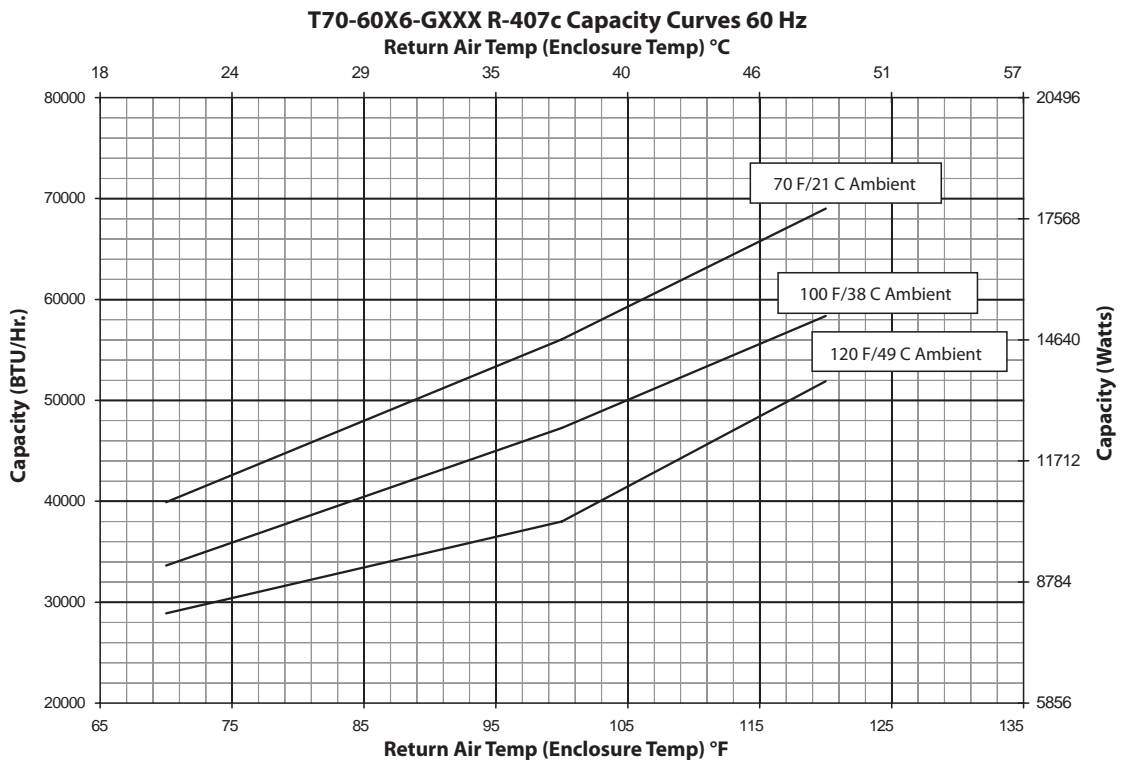
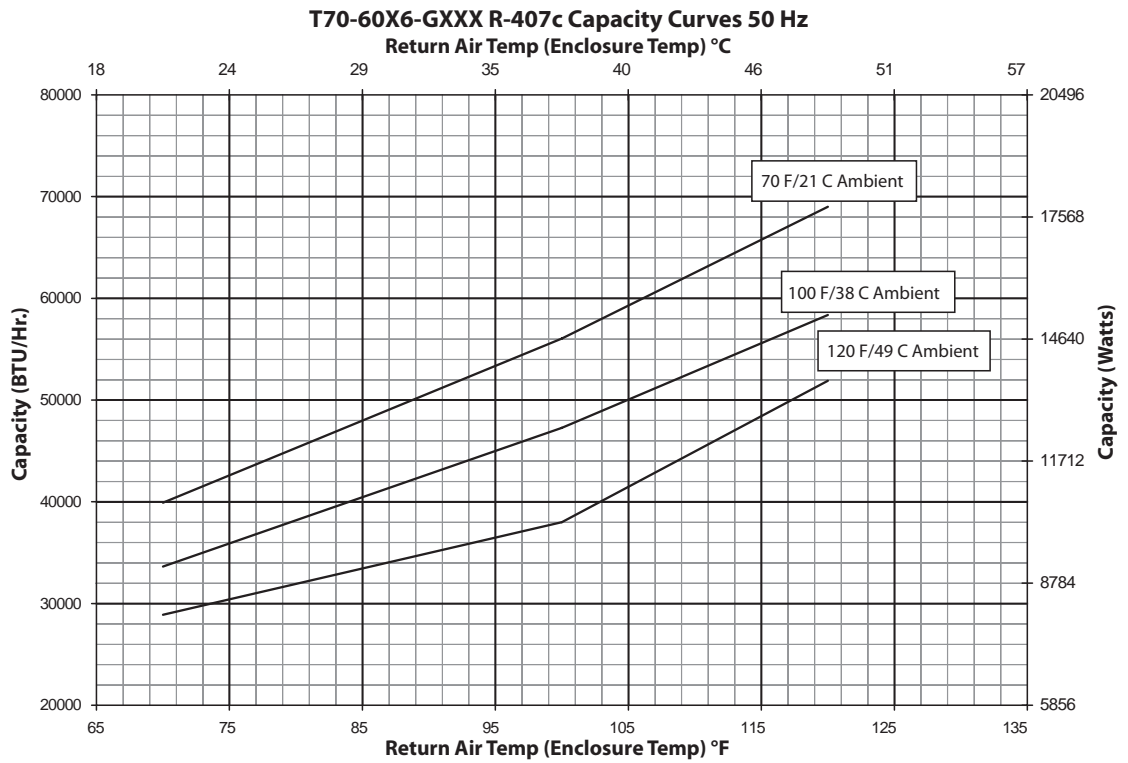

T-Series

T70 Models 59000 BTU/Hr. (17287 Watt)

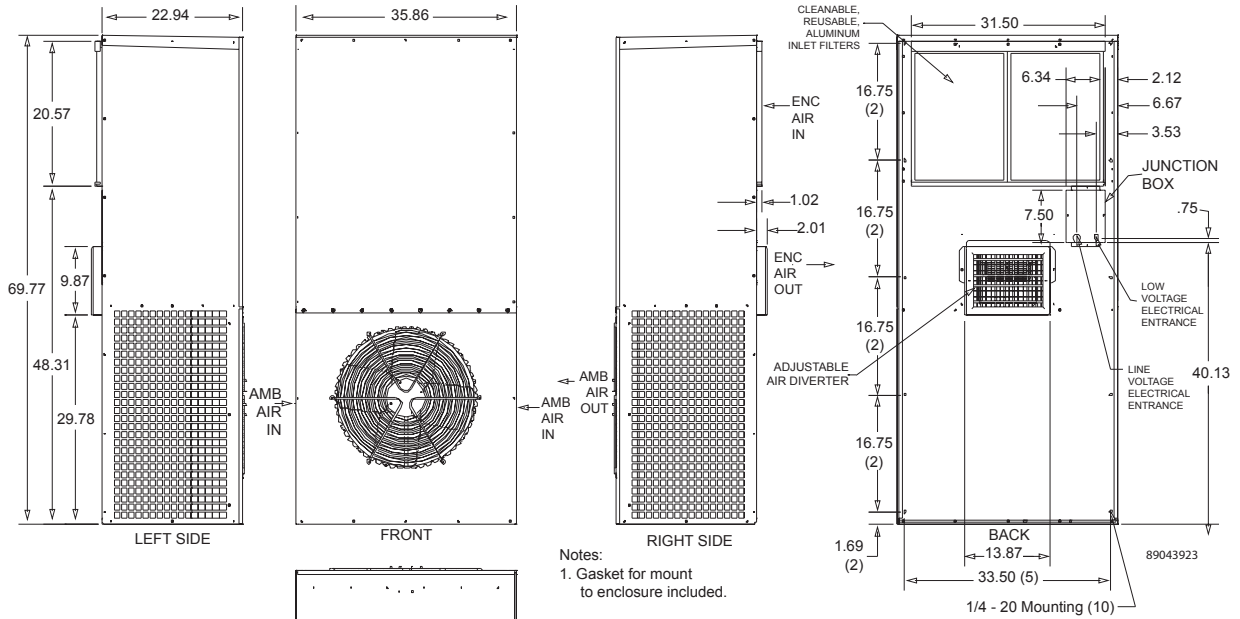

Notes:
1. Gasket for mount to enclosure included.

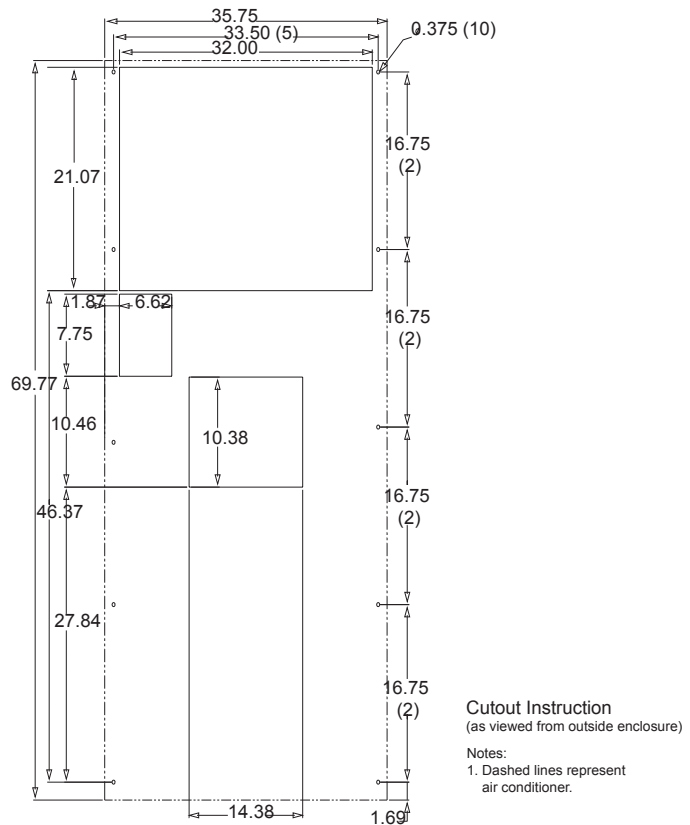
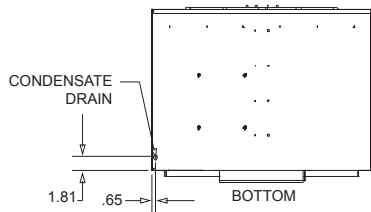

T-Series A/C

Visit www.McLeanCoolingTech.com to download 2D and 3D CAD drawings into the overall design of your electronic system.

GENESIS® Indoor Air Conditioners



M28 Model



M17 Model



*M52 460 Volt
3-Phase Model*

The specifier's choice for cooling industrial process controls



GENESIS® Indoor Air Conditioners

PRODUCT OVERVIEW

The Type 12 air conditioner of choice for light-duty manufacturing process control applications. Compact, narrow and 460 volt 3-phase models available.

APPLICATIONS

- Industrial drive enclosures
- Automotive assembly systems
- Material handling applications
- Other process control systems

GENESIS Indoor Air Conditioners Chapter Contents

Indoor Air Conditioners	76
M13 Models 1000 BTU	77
M17 Models 1800 BTU	79
M28 Models 2200 BTU	81
M28 Models 4000 BTU	82
M28 Models 6000 BTU	83
M33 Models 4000 BTU	85
M36 Models 6000 BTU	87
M52-3 3-Phase Models 4100-10000 BTU.....	89

Indoor Air Conditioners



M17
 1800 BTU/Hr.
 527 Watts



M28
 2200-6000 BTU/Hr.
 645-1758 Watts



M36
 6000 BTU/Hr.
 1760 Watts



M52 3-Phase
 4100-10000 BTU/Hr.
 1201-2930 Watts

Industry Standards

UL/cUL Listed

- CE
- Type 12

Application

- Industrial automation
- Package handling equipment
- Security and defense systems
- And more

Features

- Robust reciprocating compressor
- R134a or R407c earth-friendly refrigerant and RoHS compliant
- Models for 115, 230 and 460 single phase AC volt power input
- UL Listed or Recognized to save customers time and money with agency approvals
- Operating temperature range from 50 F/10 C to 125 F/52 C
- Attractive industrial design with minimal use of visible fasteners
- Reliable mechanical thermostat located behind the filter of the unit. Indoor Air Conditioner models include digital display on ambient side.
- Low-carbon mild-steel sheet-metal cover for rugged factory and outdoor environments
- Easy-mount flanges for simple installation
- Cleanable, reusable aluminum mesh filter to protect coils for maximum cooling performance
- Mounting hardware, gaskets and user manual furnished with the unit
- Every unit functionally tested before shipping

- Standard Indoor Air Conditioner models also include:
 - Electro-Mechanical Thermostat
 - Surge Suppressor
 - Condensate Management System

Finish

- RAL 7042 gray, semi-gloss powder-coat paint standard
- Other colors and textures available

Options

- Thermostat Malfunction Package
- Special Voltage Package
- Active Condensate Evaporator Package
- Outdoor Package*
- Harsh Environment Package*
- Stainless Steel Package*
- Heater Package*
 - * T-Series or PROAIR™ may be more appropriate. Refer to T-Series A/C and PROAIR A/C Chapters. Consult the Factory for availability and catalog number.

Notes

NOTE: M28 4000 and 6000 BTU/Hr. units are scheduled to be made obsolete June 30, 2011. Please refer to the SPECTRACOOL™ G28 at the front of this catalog.

Visit www.McLeanCoolingTech.com to download 2D and 3D CAD drawings into the overall design of your electronic system.

Performance Data **M13 Models 1000 BTU/Hr. (293 W)**

CATALOG NUMBER	M130116G1014	M130126G1008	M130146G400
COOLING PERFORMANCE			
Nominal:			
BTUs/Hr.	800/1000	800/1000	800/1000
Watts	234/293	234/293	234/293
Refrigerant	R-134A	R-134A	R-134A
Refrigerant Charge (ounces/grams)	5.5/156	5.5/156	5.5/156
Operating Temperature Range:			
Maximum (°F/°C)	125/52	125/52	125/52
Minimum (°F/°C)	50/10	50/10	50/10
Airflow at 0 Static Pressure:			
Internal loop 50 Hz (CFM/m ³ /hr.)	71/121	75/127	75/127
External loop 50 Hz (CFM/m ³ /hr.)	75/127	71/121	71/121
	74/126	78/132	78/132
External loop 60 Hz (CFM/m ³ /hr.)	78/132	74/126	74/126
ELECTRICAL DATA			
Rated Voltage	115	230	460V 1PH
Frequency (Hz)	50/60	50/60	50/60
Operating Range	+/- 10%	+/- 10%	+/- 10%
Max. Power Consumption (W at 50/60 Hz)	460	483	552
Max. Nominal Current (A at 50/60 Hz)	4	2.2/2.1	1.2
Starting Current (A)	18	8.5	5
Agency Approvals		cUL Listed CE	cUR Recognized CE
	Others available upon request		
Power Input Description	6-ft. cord with NEMA 5-15 plug	6-ft. cord with NEMA 6-15 plug	6-ft. cord with wire leads
ENCLOSURE PROTECTION			
UL Type	Type 12 standard		
CONTROLLER			
Description	Basic mechanical thermostat		
Thermostat Location	Behind filter		
Factory Thermostat Setting (°F/°C)	80/27		
SOUND LEVEL			
At 1.5 Meters	56 dB(A)		
UNIT CONSTRUCTION			
Material	Mild steel sheet metal standard Stainless steel optional		
Finish	RAL 7042 gray, semi-gloss powder-coat paint standard		
UNIT DIMENSIONS			
Height (in./mm)	13.25/337	13.25/337	17.75/450.9
Width (in./mm)	14.25/362	14.25/362	14.25/362
Depth (in./mm)	7.8/198	7.8/198	7.8/198
Weight (lb./kg)	48/22	48/22	58/26

GENESIS®

M13 Models 1000 BTU/Hr. (293 Watt)

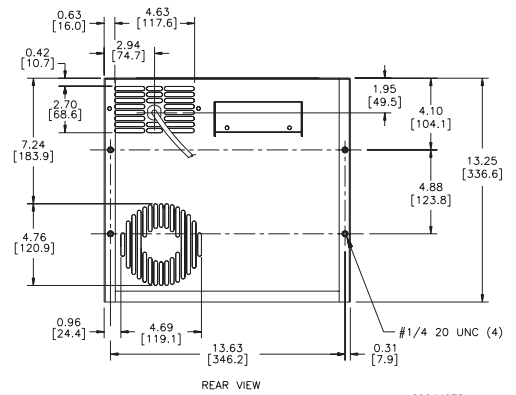
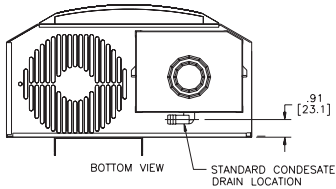
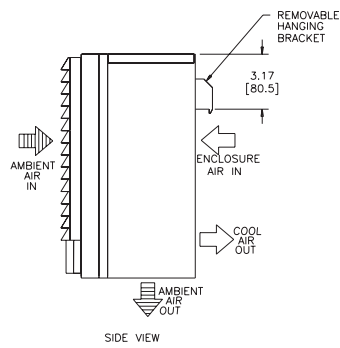
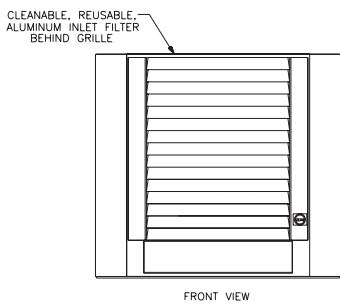
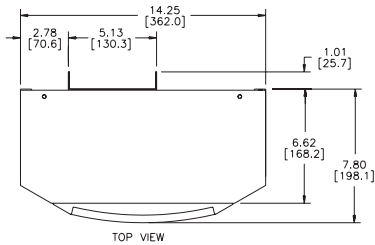

89044973

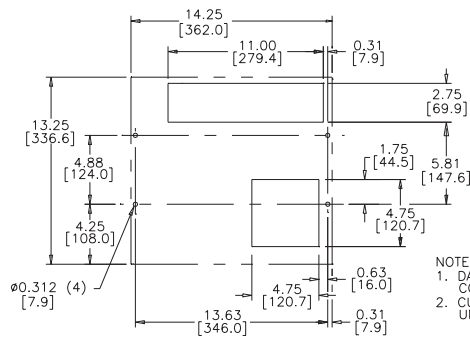

NOTES:
 1. DASHED LINES REPRESENT AIR CONDITIONER.
 2. CUT-OUT DIMENSIONS FOR STANDARD UNITS ONLY.

Cutout Instructions

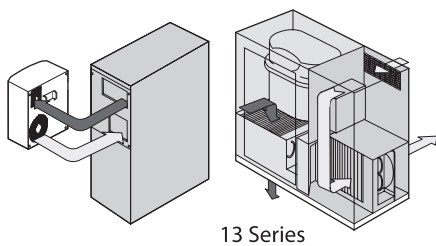

13 Series

Visit www.McLeanCoolingTech.com to download 2D and 3D CAD drawings into the overall design of your electronic system.

Performance Data **M17 Models 1800 BTU/Hr. (527 W)**

CATALOG NUMBER	M170216G009	M170226G004	M170246G400
COOLING PERFORMANCE			
Nominal:			
BTUs/Hr.	1500/1800	1500/1800	1500/1800
Watts	440/527	440/527	440/527
Refrigerant	R-134A	R-134A	R-134A
Refrigerant Charge (ounces/grams)	6/170	6/170	6/170
Operating Temperature Range:			
Maximum (°F/°C)	125/52	125/52	125/52
Minimum (°F/°C)	50/10	50/10	50/10
Airflow at 0 Static Pressure:			
Internal loop 50 Hz (CFM/m ³ /hr.)	67/114	125/212	125/212
External loop 50 Hz (CFM/m ³ /hr.)	112/190	144/245	144/245
Internal loop 60 Hz (CFM/m ³ /hr.)	79/134	125/212	125/212
External loop 60 Hz (CFM/m ³ /hr.)	130/221	161/274	161/274
ELECTRICAL DATA			
Rated Voltage	110/115	220/230	460V 1PH
Frequency (Hz)	50/60	50/60	50/60
Operating Range	+/- 10%	+/- 10%	+/- 10%
Max. Power Consumption (W at 50/60 Hz)	726/770.5	924/851	1058/920
Max. Nominal Current (A at 50/60 Hz)	6.6/6.7	4.2/3.7	2.3/2.0
Starting Current (A)	28	14.4	7.4
Agency Approvals		cUL Listed CE	cUR Recognized CE
	Others available upon request		
Power Input Description	6-ft. cord with NEMA 5-15 plug	6-ft. cord with NEMA 6-15 plug	6-ft. cord with wire leads
ENCLOSURE PROTECTION			
UL Type	Type 12 standard		
CONTROLLER			
Description	Basic mechanical thermostat		
Thermostat Location	Behind filter		
Factory Thermostat Setting (°F/°C)	80/27		
SOUND LEVEL			
At 1.5 Meters	60 dB(A)		
UNIT CONSTRUCTION			
Material	Mild steel sheet metal standard Stainless steel optional		
Finish	RAL 7042 gray, semi-gloss powder-coat paint standard		
UNIT DIMENSIONS			
Height (in./mm)	17.65/448	17.65/448	22.15/562.6
Width (in./mm)	12/305	12/305	12/305
Depth (in./mm)	8.68/220	8.68/220	8.68/220
Weight (lb./kg)	56/25	56/25	66/30

M17 Models 1800 BTU/Hr. (527 Watt)

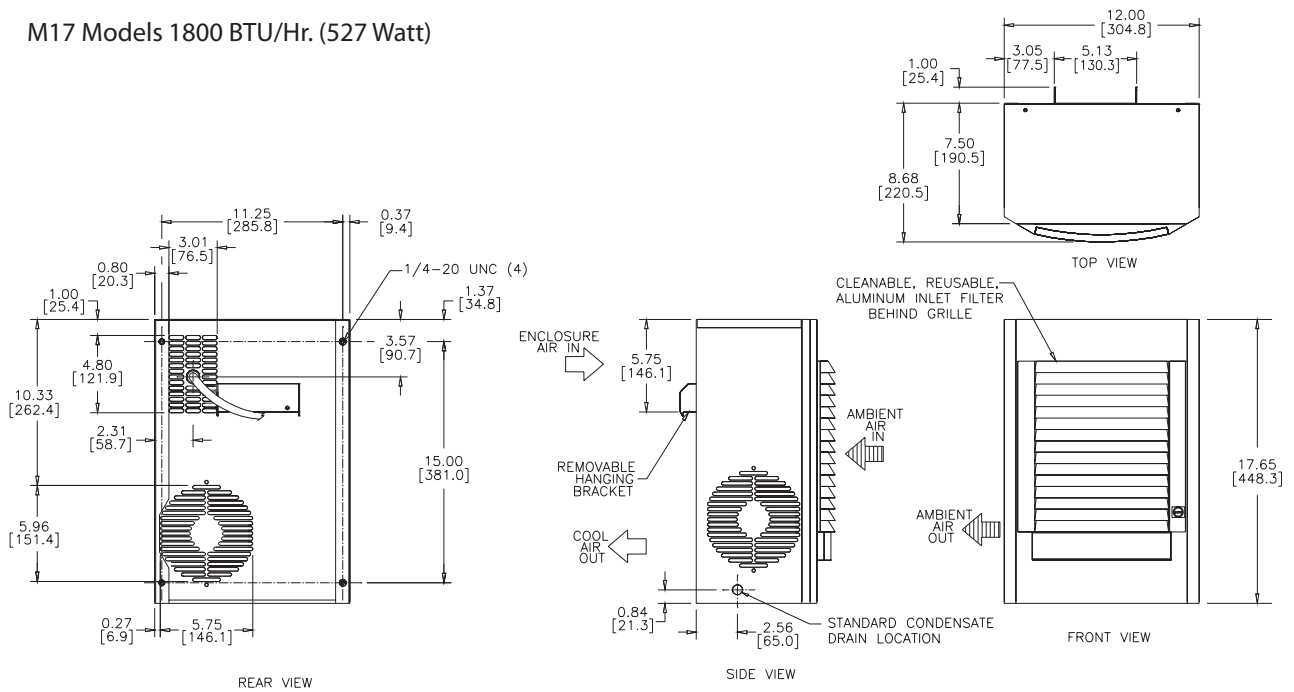

89044974

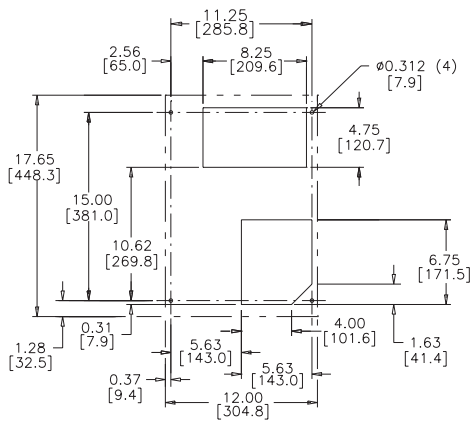

- NOTES:
 1. DASHED LINES REPRESENT AIR CONDITIONER.
 2. CUT-OUT DIMENSIONS FOR STANDARD UNITS ONLY.

Cutout Instructions

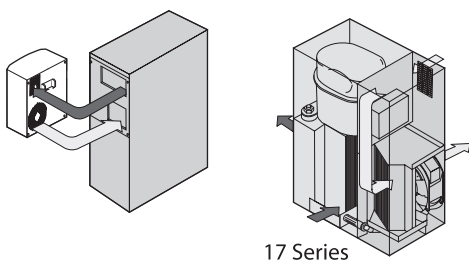

Visit www.McLeanCoolingTech.com to download 2D and 3D CAD drawings into the overall design of your electronic system.

Performance Data **M28 Models 2200 BTU/Hr. (645 W)**

CATALOG NUMBER	M280216G013	M280226G004	M280246G400
COOLING PERFORMANCE			
Nominal:			
BTUs/Hr.	2200/2200	2200/2200	2200/2200
Watts	645/645	645/645	645/645
Refrigerant	R-134A	R-134A	R-134A
Refrigerant Charge (ounces/grams)	11/312	10/284	10/284
Operating Temperature Range:			
Maximum (°F/°C)	125/52	125/52	125/52
Minimum (°F/°C)	50/10	50/10	50/10
Airflow at 0 Static Pressure:			
Internal loop 50 Hz (CFM/m ³ /hr.)	146/248	175/297	175/297
External loop 50 Hz (CFM/m ³ /hr.)	230/391	225/382	225/382
Internal loop 60 Hz (CFM/m ³ /hr.)	170/289	210/357	210/357
External loop 60 Hz (CFM/m ³ /hr.)	260/442	255/433	255/433
ELECTRICAL DATA			
Rated Voltage	115	230	460V 1PH
Frequency (Hz)	50/60	50/60	50/60
Operating Range	+/- 10%	+/- 10%	+/- 10%
Max. Power Consumption (W at 50/60 Hz)	1127/1035	1150/1035	1288/1150
Max. Nominal Current (A at 50/60 Hz)	9.8/9.0	5.0/4.5	2.8/2.5
Starting Current (A)	28	14.4	7.4
Agency Approvals		cUL Listed CE	cUR Recognized CE
	Others available upon request		
Power Input Description	6-ft. cord with NEMA 5-15 plug	6-ft. cord with NEMA 6-15 plug	6-ft. cord with wire leads
ENCLOSURE PROTECTION			
UL Type	Type 12 standard		
CONTROLLER			
Description	Basic mechanical thermostat		
Thermostat Location	Behind filter		
Factory Thermostat Setting (°F/°C)	80/27		
SOUND LEVEL			
At 1.5 Meters	55 dB(A)		
UNIT CONSTRUCTION			
Material	Mild steel sheet metal standard Stainless steel optional		
Finish	RAL 7042 gray, semi-gloss powder-coat paint standard		
UNIT DIMENSIONS			
Height (in./mm)	28.5/724	28.5/724	28.5/724
Width (in./mm)	17/432	17/432	17/432
Depth (in./mm)	11.3/288	11.3/288	11.3/288
Weight (lb./kg)	98/45	98/45	108/49

Performance Data **M28 Models 4000 BTU/Hr. (1172 W)**

CATALOG NUMBER			
	M280416G007	M280426G032	M280446G400
COOLING PERFORMANCE			
Nominal:			
BTUs/Hr.	3800/4000	3800/4000	3800/4000
Watts	1114/1172	1114/1172	1114/1172
Refrigerant	R-134A	R-134A	R-134A
Refrigerant Charge (ounces/grams)	11/312	11/312	11/312
Operating Temperature Range:			
Maximum (°F/°C)	125/52	125/52	125/52
Minimum (°F/°C)	50/10	50/10	50/10
Airflow at 0 Static Pressure:			
Internal loop 50 Hz (CFM/m ³ /hr.)	153/260	146/248	146/248
External loop 50 Hz (CFM/m ³ /hr.)	230/391	225/382	225/382
Internal loop 60 Hz (CFM/m ³ /hr.)	174/296	166/282	166/282
External loop 60 Hz (CFM/m ³ /hr.)	260/442	255/433	255/433
ELECTRICAL DATA			
Rated Voltage	115	230	460V 1PH
Frequency (Hz)	50/60	50/60	50/60
Operating Range	+/- 10%	+/- 10%	+/- 10%
Max. Power Consumption (W at 50/60 Hz)	1679/1610	1702/1587	1886/1748
Max. Nominal Current (A at 50/60 Hz)	14.6/14.0	7.4/6.9	4.1/3.8
Starting Current (A)	48	23	12
Agency Approvals		cUL Listed CE	cUR Recognized CE
	Others available upon request		
Power Input Description	NEMA 5-20 plug on 6-ft. cord	NEMA 6-15 plug on 6-ft. cord	6-ft. cord with wire terminations
ENCLOSURE PROTECTION			
UL Type	Type 12 standard		
CONTROLLER			
Description	Basic mechanical thermostat		
Thermostat Location	Behind filter		
Factory Thermostat Setting (°F/°C)	80/27		
SOUND LEVEL			
At 1.5 Meters	62 dB(A)		
UNIT CONSTRUCTION			
Material	Mild steel sheet metal standard Stainless steel optional		
Finish	RAL 7042 gray, semi-gloss powder-coat paint standard		
UNIT DIMENSIONS			
Height (in./mm)	28.5/724	28.5/724	28.5/724
Width (in./mm)	17/432	17/432	17/432
Depth (in./mm)	11.3/288	11.3/288	11.3/288
Weight (lb./kg)	116/53	116/53	136/62

NOTE: These units are scheduled to be made obsolete June 30, 2011. Please refer to the SPECTRACOOL™ G28 at the front of this catalog.

Technical Data **M28 Models 6000 BTU/Hr. (1758 W)**

CATALOG NUMBER	M280616G005	M280626G005	M280646G400
COOLING PERFORMANCE			
Nominal:			
BTUs/Hr.	5400/6000	5400/6000	5400/6000
Watts	1582/1758	1582/1758	1582/1758
Refrigerant	R-134A	R-134A	R-134A
Refrigerant Charge (ounces/grams)	15/425	15/425	15/425
Operating Temperature Range:			
Maximum (°F/°C)	125/52	125/52	125/52
Minimum (°F/°C)	50/10	50/10	50/10
Airflow at 0 Static Pressure:			
Internal loop 50 Hz (CFM/m ³ /hr.)	153/260	146/248	146/248
External loop 50 Hz (CFM/m ³ /hr.)	325/552	325/552	325/552
Internal loop 60 Hz (CFM/m ³ /hr.)	174/296	166/282	166/282
External loop 60 Hz (CFM/m ³ /hr.)	373/634	373/634	373/634
ELECTRICAL DATA			
Rated Voltage	115	230	460V 1PH
Frequency (Hz)	50/60	50/60	50/60
Operating Range	+/- 10%	+/- 10%	+/- 10%
Max. Power Consumption (W at 50/60 Hz)	1886/1978	1840	2024
Max. Nominal Current (A at 50/60 Hz)	16.4/17.2	8	4.4
Starting Current (A)	58.8	27.4	14
Agency Approvals	cUR Recognized CE	cUL Listed CE	cUR Recognized CE
Power Input Description	6-ft. cord with wire leads	6-ft. cord with NEMA 6-15 plug	6-ft. cord with wire leads
ENCLOSURE PROTECTION			
UL Type	Type 12 standard		
CONTROLLER			
Description	Basic mechanical thermostat		
Thermostat Location	Behind filter		
Factory Thermostat Setting (°F/°C)	80/27		
SOUND LEVEL			
At 1.5 Meters	62 dB(A)		
UNIT CONSTRUCTION			
Material	Mild steel sheet metal standard Stainless steel optional		
Finish	RAL 7042 gray, semi-gloss powder-coat paint standard		
UNIT DIMENSIONS			
Height (in./mm)	28.5/724		
Width (in./mm)	17/432		
Depth (in./mm)	11.3/288		
Weight (lb./kg)	120/55	120/55	150/68

NOTE: These units are scheduled to be made obsolete June 30, 2011. Please refer to the SPECTRACOOL™ G28 at the front of this catalog.

M28 Models 2200-6000 BTU/Hr. (645-1758 Watt)

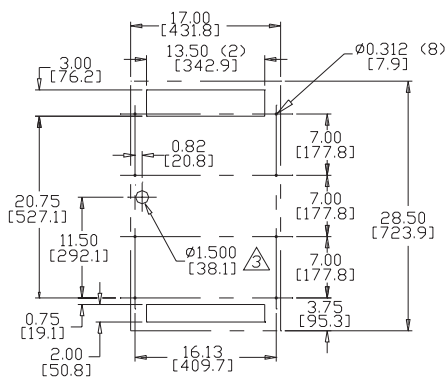
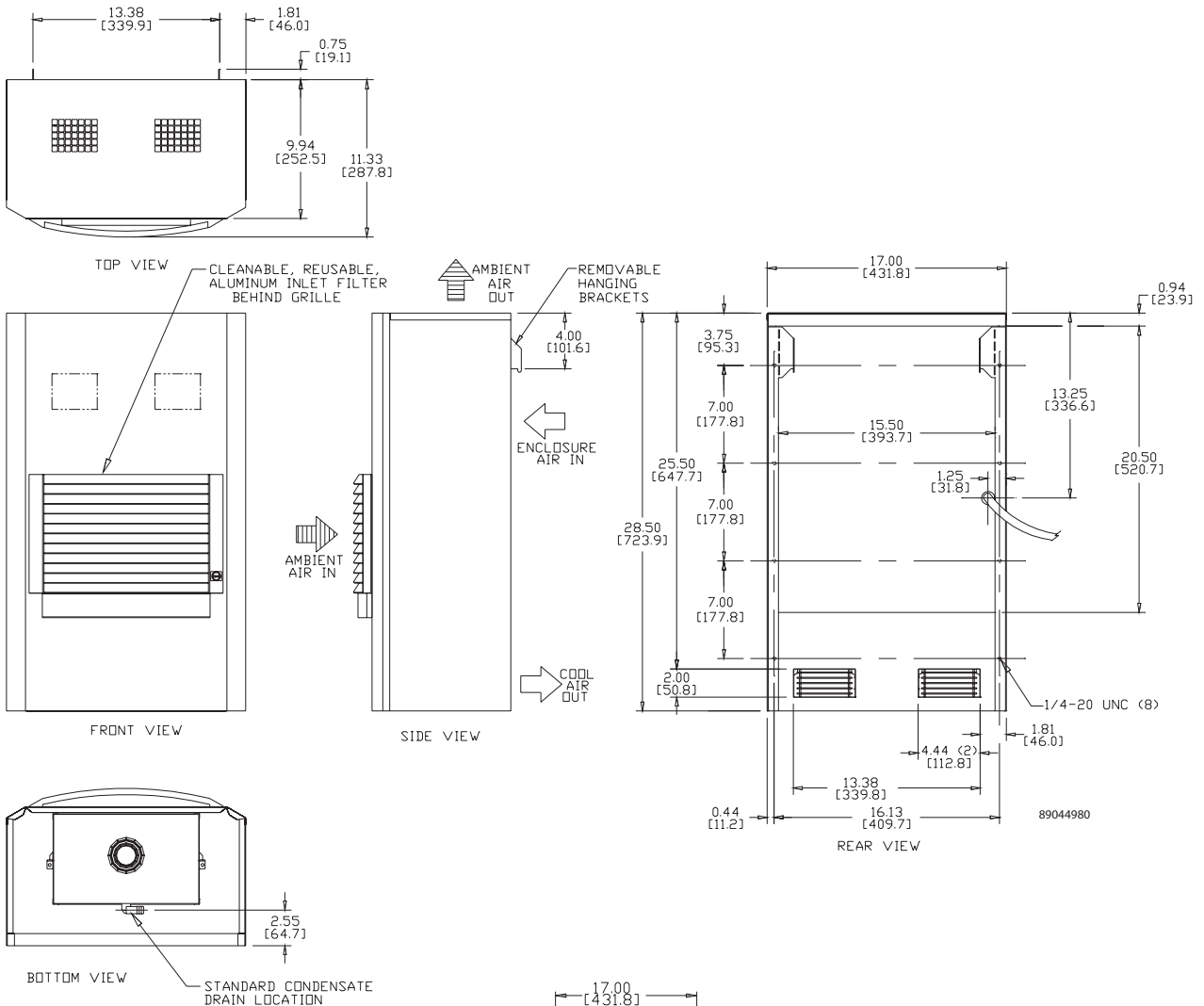

- NOTES:
 1. DASHED LINES REPRESENT AIR CONDITIONER.
 2. CUT-OUT DIMENSIONS FOR STANDARD UNITS ONLY.
 ⚠ THIS HOLE MAY BE DELETED IF THE SERVICE CORD IS ROUTED THROUGH THE 3" x 13-1/2" OPENING. (EXCEPT UNITS WITH ELECTRIC HEAT)

Visit www.McLeanCoolingTech.com to download 2D and 3D CAD drawings into the overall design of your electronic system.

Performance Data **M33 Models 4000 BTU/Hr. (1172 W)**

CATALOG NUMBER	M330416G010	M330426G009	M330446G400
COOLING PERFORMANCE			
Nominal:			
BTUs/Hr.	3700/4000	3700/4000	3700/4000
Watts	1084/1172	1084/1172	1084/1172
Refrigerant	R-134A	R-134A	R-134A
Refrigerant Charge (ounces/grams)	14/398	14/398	14/398
Operating Temperature Range:			
Maximum (°F/°C)	125/52	125/52	125/52
Minimum (°F/°C)	50/10	50/10	50/10
Airflow at 0 Static Pressure:			
Internal loop 50 Hz (CFM/m ³ /hr.)	135/229	100/170	100/170
External loop 50 Hz (CFM/m ³ /hr.)	300/510	296/503	296/503
Internal loop 60 Hz (CFM/m ³ /hr.)	145/246	110/187	110/187
External loop 60 Hz (CFM/m ³ /hr.)	355/603	349/593	349/593
ELECTRICAL DATA			
Rated Voltage	115	230	460V 1PH
Frequency (Hz)	50/60	50/60	50/60
Operating Range	+/- 10%	+/- 10%	+/- 10%
Max. Power Consumption (W at 50/60 Hz)	1495/1518	1656/1679	1840
Max. Nominal Current (A at 50/60 Hz)	13.0/13.2	7.2/7.3	4
Starting Current (A)	48	23	12
Agency Approvals		cUL Listed CE	cUR Recognized CE
Power Input Description	6-ft. cord with NEMA 5-20 plug	6-ft. cord with NEMA 6-15 plug	6-ft. cord with wire leads
ENCLOSURE PROTECTION			
UL Type	Type 12 standard		
CONTROLLER			
Description	Basic mechanical thermostat		
Thermostat Location	Behind filter		
Factory Thermostat Setting (°F/°C)	80/27		
SOUND LEVEL			
At 1.5 Meters	61 dB(A)		
UNIT CONSTRUCTION			
Material	Mild steel sheet metal standard Stainless steel optional		
Finish	RAL 7042 gray, semi-gloss powder-coat paint standard		
UNIT DIMENSIONS			
Height (in./mm)	34.37/873	34.37/873	34.37/873
Width (in./mm)	12/305	12/305	12/305
Depth (in./mm)	9.88/251	9.88/251	9.88/251
Weight (lb./kg)	105/48	105/48	125/57

M33 Models 4000 BTU/Hr. (1172 Watt)

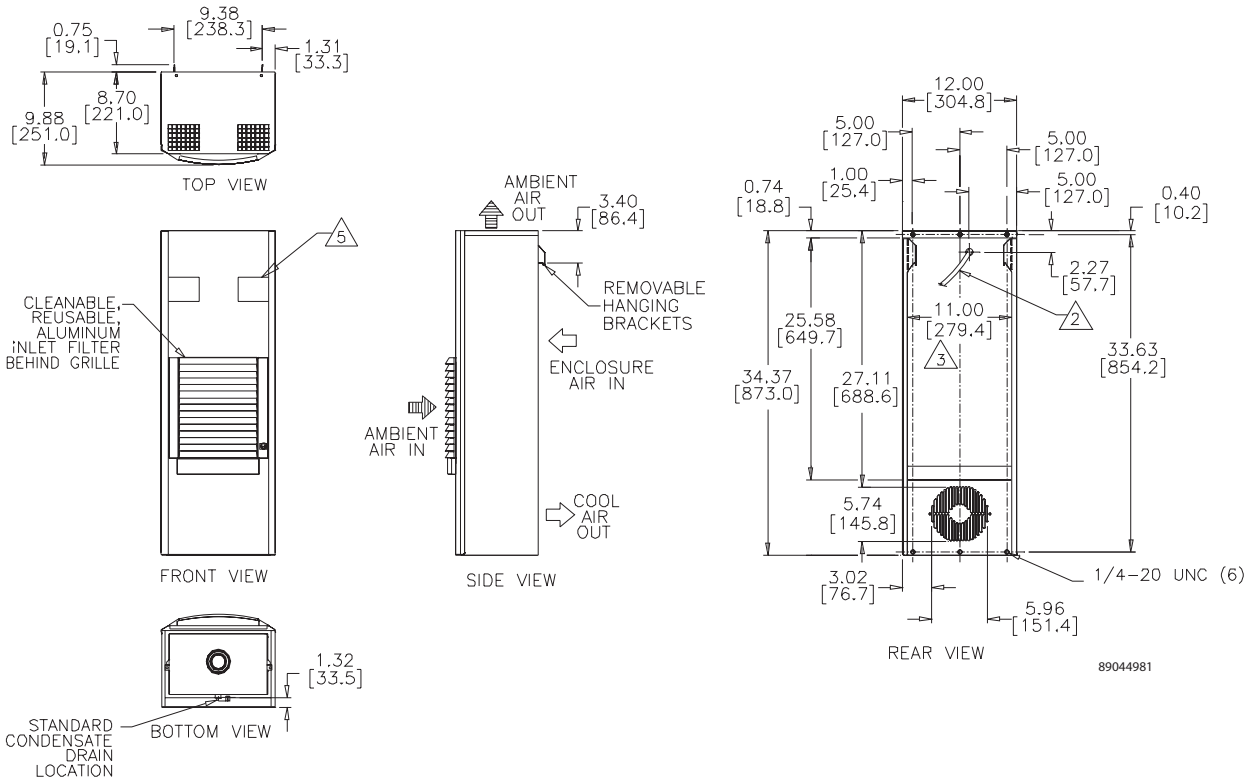

GENESIS A/C

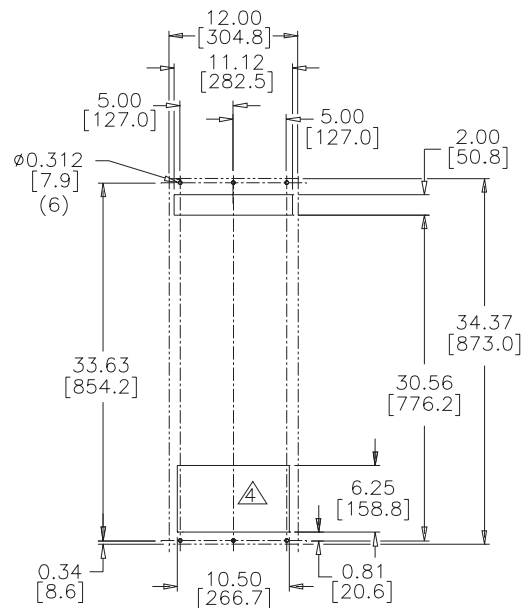
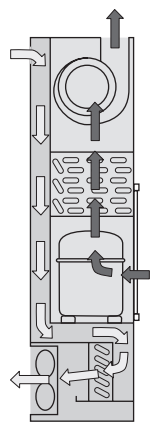
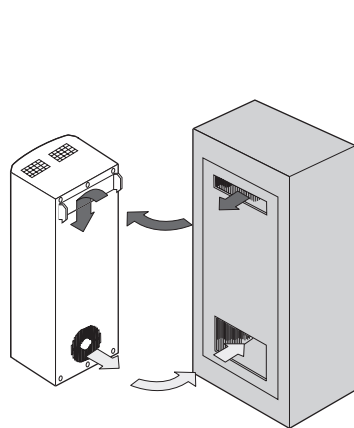

Visit www.McLeanCoolingTech.com to download 2D and 3D CAD drawings into the overall design of your electronic system.

Performance Data **M36 Models 6000 BTU/Hr. (1760 W)**

CATALOG NUMBER	M360616G307	M360626G306	M360646G400
COOLING PERFORMANCE			
Nominal:			
BTUs/Hr.	5000/6000	5000/6000	5000/6000
Watts	1465/1760	1465/1760	1465/1760
Refrigerant	R-407C	R-407C	R-407C
Refrigerant Charge (ounces/grams)	18/510	18/510	18/510
Operating Temperature Range:			
Maximum (°F/°C)	125/52	125/52	125/52
Minimum (°F/°C)	50/10	50/10	50/10
Airflow at 0 Static Pressure:			
Internal loop 50 Hz (CFM/m ³ /hr.)	230/391	230/391	230/391
External loop 50 Hz (CFM/m ³ /hr.)	218/370	218/370	218/370
Internal loop 60 Hz (CFM/m ³ /hr.)	260/442	260/442	260/442
External loop 60 Hz (CFM/m ³ /hr.)	245/416	245/416	245/416
ELECTRICAL DATA			
Rated Voltage	115	230	460V 1PH
Frequency (Hz)	50/60	50/60	50/60
Operating Range	+/- 10%	+/- 10%	+/- 10%
Max. Power Consumption (W at 50/60 Hz)	1150	1150	1288
Max. Nominal Current (A at 50/60 Hz)	10	5	2.8
Starting Current (A)	36.2	17.7	9
Agency Approvals	cUL Listed CE Others available upon request		cUR Recognized CE
Power Input Description	6-ft. cord with NEMA 5-20 plug	6-ft. cord with NEMA 6-15 plug	6-ft. cord with wire leads
ENCLOSURE PROTECTION			
UL Type	Type 12 standard		
CONTROLLER			
Description	Basic mechanical thermostat		
Thermostat Location	Behind filter		
Factory Thermostat Setting (°F/°C)	80/27		
SOUND LEVEL			
At 1.5 Meters	60 dB(A)		
UNIT CONSTRUCTION			
Material	Mild steel sheet metal standard Stainless steel optional		
Finish	RAL 7042 gray, semi-gloss powder-coat paint standard		
UNIT DIMENSIONS			
Height (in./mm)	38.72/984	38.72/984	38.72/984
Width (in./mm)	15/381	15/381	15/381
Depth (in./mm)	11.33/288	11.33/288	11.33/288
Weight (lb./kg)	120/54	120/54	140/64

GENESIS®

M36 Models 6000 BTU/Hr. (1760 Watt)

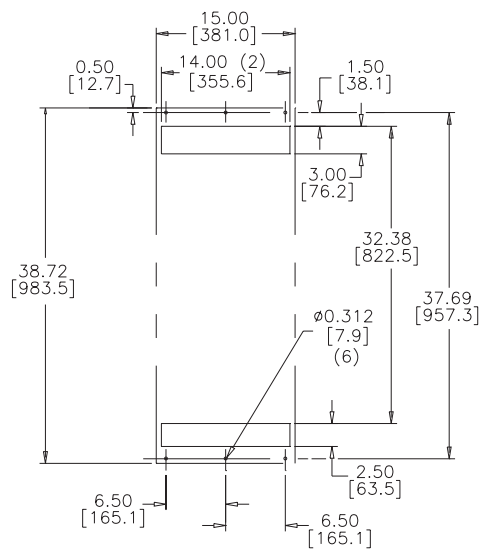
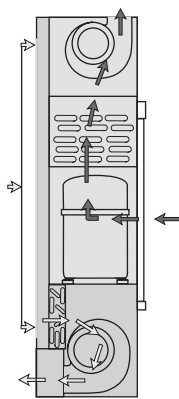
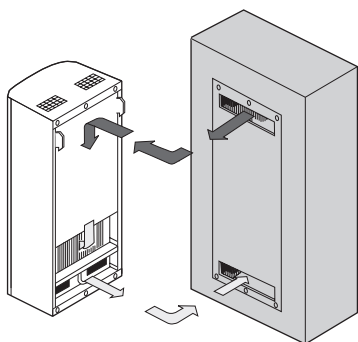
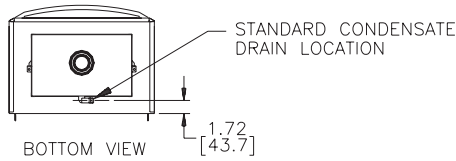
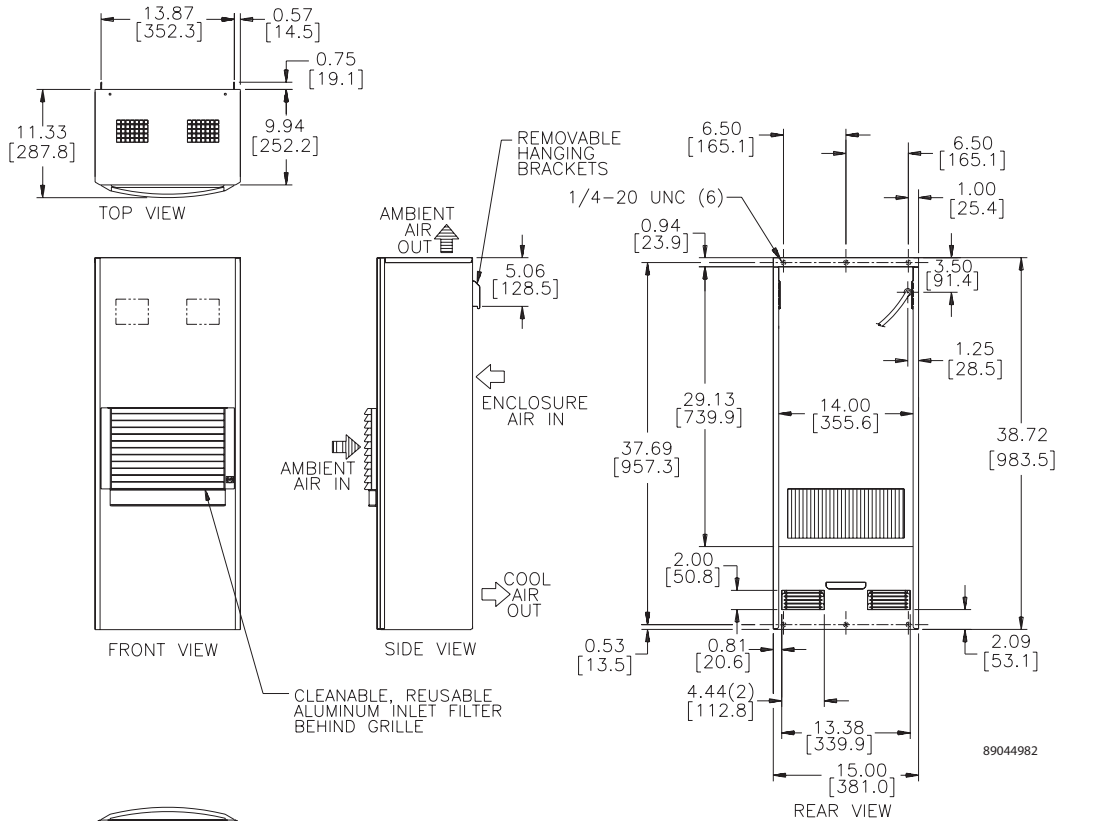

- NOTES:
1. SERVICE CORD IS ROUTED THROUGH 3.00 X 14.00 RETURN AIR OPENING.
 2. DASHED LINES REPRESENT AIR CONDITIONER.
 3. CUT-OUT DIMENSIONS FOR STANDARD UNITS ONLY.

Visit www.McLeanCoolingTech.com to download 2D and 3D CAD drawings into the overall design of your electronic system.

Performance Data **M52-3 Phase Models 4100-10000 BTU/Hr. (1113-2930 W)**

CATALOG NUMBER	M520446G002	M520646G002	M520846G002	M521046G002
COOLING PERFORMANCE				
Nominal:				
BTUs/Hr.	3800/4100	5000/6000	6500/7500	8000/10000
Watts	1113/1201	1465/1760	1905/2198	2345/2930
Refrigerant	R-134A	R-134A	R-134A	R-134A
Refrigerant Charge (ounces/grams)	14/397	17/482	13.5/382	29/824
Operating Temperature Range:				
Maximum (°F/°C)	131/55	125/52	131/55	131/55
Minimum (°F/°C)	50/10	50/10	50/10	50/10
Airflow at 0 Static Pressure:				
Internal loop 50 Hz (CFM/m ³ /hr.)	225/382	225/382	225/382	225/382
External loop 50 Hz (CFM/m ³ /hr.)	500/850	500/850	500/850	500/850
Internal loop 60 Hz (CFM/m ³ /hr.)	270/459	270/459	248/421	266/452
External loop 60 Hz (CFM/m ³ /hr.)	578/982	578/982	578/982	578/982
ELECTRICAL DATA				
Rated Voltage	*400/440/460 3~	400/440/460/3~	*400/440/460 3~	*400/440/460 3~
Frequency (Hz)	50/60	50/60	50/60	50/60
Operating Range	* Min./Max. +/- 10%	* Min./Max. +/- 10%	* Min./Max. +/- 10%	* Min./Max. +/- 10%
Max. Power Consumption (W at 50/60 Hz)	705.5/782	830/828	1453/1472	1536/1564
Max. Nominal Current (A at 50/60 Hz)	1.7	2.0/1.8	3.5/3.2	3.7/3.4
Starting Current (A)	15.4	15.4	20	26
Agency Approvals	cUL Listed CE Others available upon request		cUL Listed CE Others available upon request	
Power Input Description	Terminal block		Terminal block	
ENCLOSURE PROTECTION				
UL Type	Type 12 standard			
CONTROLLER				
Description	Basic mechanical thermostat			
Thermostat Location	Behind filter			
Factory Thermostat Setting (°F/°C)	80/27			
SOUND LEVEL				
At 1.5 Meters	67 dB(A)			
UNIT CONSTRUCTION				
Material	Mild steel sheet metal standard Stainless steel optional			
Finish	RAL 7042 gray, semi-gloss powder-coat paint standard			
UNIT DIMENSIONS				
Height (in./mm)	52.63/1337	52.63/1337	52.63/1337	52.63/1337
Width (in./mm)	17.13/435	17.13/435	17.13/435	17.13/435
Depth (in./mm)	11.33/288	11.33/288	11.33/288	13.33/339
Weight (lb./kg)	162/74	162/74	162/74	165/75

GENESIS®

M52-3 Phase Models 4100-10000 BTU/Hr. (1201-2930 Watt)

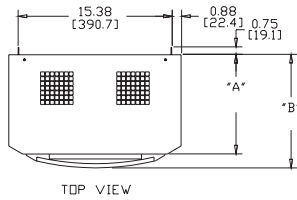

MODEL NO.	DIM.'A'	DIM.'B'
M52-0446 M52-0646 & 0846-GXXX	9.94"	11.33"
M52-1046-GXXX	11.94"	13.33"

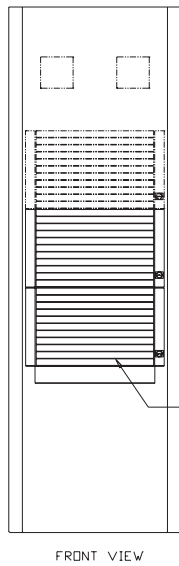

CLEANABLE, REUSABLE ALUMINUM INLET FILTERS BEHIND GRILLES
4000 - 8000 BTU MODELS USE TWO GRILLES 10000 BTU USES THREE GRILLES

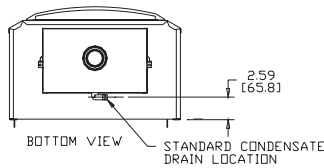
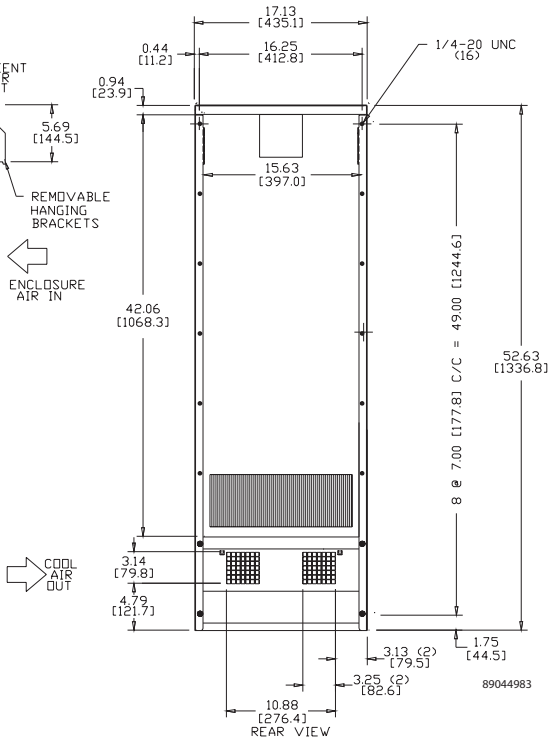
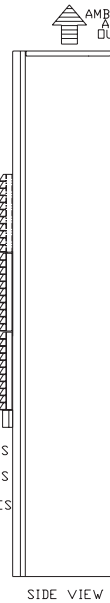

■ Ambient airflow
■ Clean airflow

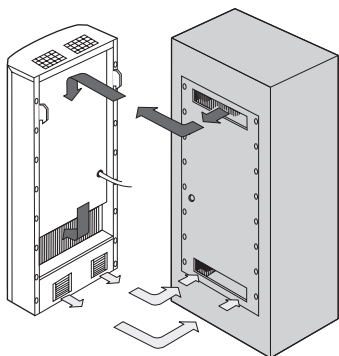

Side-Mount to Enclosure

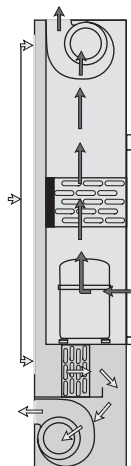

52 Series

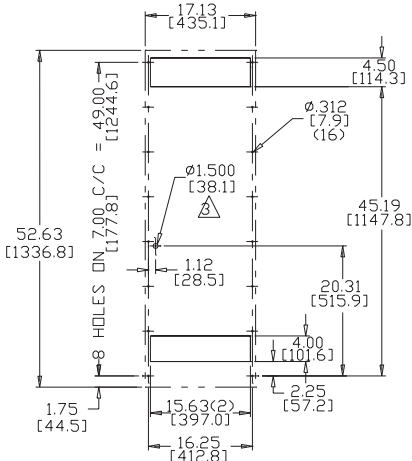

Cutout Instructions

- NOTES:
1. DASHED LINES REPRESENT AIR CONDITIONER.
 2. CUT-OUT DIMENSIONS FOR STANDARD UNITS ONLY.
 3. THIS HOLE MAY BE DELETED IF THE SERVICE CORD IS ROUTED THROUGH THE 4.50" X 15.63" OPENING. (EXCEPT UNITS WITH ELECTRIC HEAT)

Visit www.McLeanCoolingTech.com to download 2D and 3D CAD drawings into the overall design of your electronic system.

Notes

GENESIS® Top-Mount Air Conditioners



MHB11 Model

The perfect cooling solution when side-mount air conditioning is not an option



GENESIS® Top-Mount Air Conditioners

PRODUCT OVERVIEW

The perfect temperature control solution when you don't have room to hang a cooling unit on the side of your electrical enclosure.

APPLICATIONS

- Industrial drive enclosures
- Automotive assembly systems
- Material handling applications
- Other process control systems

GENESIS Top-Mount Air Conditioners Chapter Contents

Top-Mount Air Conditioners	94
MHB11 Models 2200 BTU	95
MHB11 Models 4000 BTU	96
HB16 Models 8000 BTU	98

MHB11 Top-Mount Air Conditioners



Industry Standards

UL/cUL Listed

- CE
- Type 12

Application

- Industrial automation
- Package handling equipment
- Security and defense systems
- Ideal for use where there is little or no clearance around the enclosure

Features

- Robust reciprocating compressor
- R134a earth-friendly refrigerant and RoHS compliant
- Models for 115, 230 and 460 single-phase AC volt power input
- UL Listed or Recognized to save customers time and money with agency approvals
- Operating temperature range from 50 F/10 C to 125 F/52 C
- Attractive industrial design with minimal use of visible fasteners
- Reliable mechanical thermostat located behind the filter of the unit. Indoor Air Conditioner models include digital display on ambient side.

- Low-carbon mild-steel sheet-metal cover for rugged factory environments
- Cleanable, reusable aluminum mesh filter to protect coils for maximum cooling performance
- Mounting hardware, gaskets and user manual furnished with the unit
- Every unit functionally tested before shipping
- Standard Indoor Air Conditioner models also include:
 - Electro-Mechanical Thermostat
 - Surge Suppressor
 - Condensate Management System

Finish

- RAL 7042 gray, semi-gloss powder-coat paint standard
- Other colors and textures available

Options

- Thermostat Malfunction Package
- Special Voltage Package
 - * Consult the factory for availability and catalog number

Notes

Visit www.McLeanCoolingTech.com to download 2D and 3D CAD drawings into the overall design of your electronic system.

Performance Data **MHB11 Models 2200 BTU/Hr. (645 W)**

CATALOG NUMBER	MHB110216G306	MHB110226G306	MHB110246G400
COOLING PERFORMANCE			
Nominal:			
BTUs/Hr.	2200/2200	2200/2200	2200/2200
Watts	645/645	645/645	645/645
Refrigerant	R-134A	R-134A	R-134A
Refrigerant Charge (ounces/grams)	11/312	11/312	11/312
Operating Temperature Range:			
Maximum (°F/°C)	125/52	125/52	125/52
Minimum (°F/°C)	50/10	50/10	50/10
Airflow at 0 Static Pressure:			
Internal loop 50 Hz (CFM/m ³ /hr.)	158/268	170/289	170/289
External loop 50 Hz (CFM/m ³ /hr.)	222/377	218/370	218/370
Internal loop 60 Hz (CFM/m ³ /hr.)	177/301	192/326	192/326
External loop 60 Hz (CFM/m ³ /hr.)	252/428	245/416	245/416
ELECTRICAL DATA			
Rated Voltage	115	220/230	440/460V 1PH
Frequency (Hz)	50/60	50/60	50/60
Operating Range	+/- 10%	+/- 10%	+/- 10%
Max. Power Consumption (W at 50/60 Hz)	1127/1035	1210/1058	1320/1150
Max. Nominal Current (A at 50/60 Hz)	9.8/9.0	5.5/4.6	3.0/2.5
Starting Current (A)	28	14.4	7.4
Agency Approvals		cUL Listed CE	cUR Recognized CE
	Others available upon request		
Power Input Description	6-ft. cord with NEMA 5-15 plug	6-ft. cord with NEMA 6-15 plug	6-ft. cord with wire leads
ENCLOSURE PROTECTION			
UL Type	Type 12 standard		
CONTROLLER			
Description	Basic mechanical thermostat		
Thermostat Location	Behind filter		
Factory Thermostat Setting (°F/°C)	80/27		
SOUND LEVEL			
At 1.5 Meters	62 dB(A)		
UNIT CONSTRUCTION			
Material	Mild steel sheet metal standard Stainless steel optional		
Finish	RAL 7042 gray, semi-gloss powder-coat paint standard		
UNIT DIMENSIONS			
Height (in./mm)	10.25/260	10.25/260	10.25/260
Width (in./mm)	17/432	17/432	17/432
Depth (in./mm)	21.08/535	21.08/535	21.08/535
Weight (lb./kg)	90/41	90/41	110/50

Performance Data **MHB11 Models 4000 BTU/Hr. (1172 W)**

CATALOG NUMBER			
	MHB110416G307	MHB110426G306	MHB110446G400
COOLING PERFORMANCE			
Nominal:			
BTUs/Hr.	3300/4000	3300/4000	3300/4000
Watts	967/1172	967/1172	967/1172
Refrigerant	R-134A	R-134A	R-134A
Refrigerant Charge (ounces/grams)	13/369	13/369	13/369
Operating Temperature Range:			
Maximum (°F/°C)	125/52	125/52	125/52
Minimum (°F/°C)	50/10	50/10	50/10
Airflow at 0 Static Pressure:			
Internal loop 50 Hz (CFM/m ³ /hr.)	158/268	170/289	170/289
External loop 50 Hz (CFM/m ³ /hr.)	222/377	218/370	218/370
Internal loop 60 Hz (CFM/m ³ /hr.)	177/301	192/326	192/326
External loop 60 Hz (CFM/m ³ /hr.)	252/428	245/416	245/416
ELECTRICAL DATA			
Rated Voltage	110/115	220/230	440/460V 1PH
Frequency (Hz)	50/60	50/60	50/60
Operating Range	+/- 10%	+/- 10%	+/- 10%
Max. Power Consumption (W at 50/60 Hz)	1617/1564	1760/1725	1936/1886
Max. Nominal Current (A at 50/60 Hz)	14.7/13.6	8.0/7.5	4.4/4.1
Starting Current (A)	48	23	12
Agency Approvals		cUL Listed CE	cUR Recognized CE
	Others available upon request		
Power Input Description	6-ft. cord with NEMA 5-20 plug	6-ft. cord with NEMA 6-15 plug	6-ft. cord with wire leads
ENCLOSURE PROTECTION			
UL Type	Type 12 standard		
CONTROLLER			
Description	Basic mechanical thermostat		
Thermostat Location	Behind filter		
Factory Thermostat Setting (°F/°C)	80/27		
SOUND LEVEL			
At 1.5 Meters	62 dB(A)		
UNIT CONSTRUCTION			
Material	Mild steel sheet metal standard Stainless steel optional		
Finish	RAL 7042 gray, semi-gloss powder-coat paint standard		
UNIT DIMENSIONS			
Height (in./mm)	10.25/260	10.25/260	10.25/260
Width (in./mm)	17/432	17/432	17/432
Depth (in./mm)	21.08/535	21.08/535	21.08/535
Weight (lb./kg)	108/49	108/49	128/58

MHB11 Models 2200-4000 BTU/Hr. (645-1172 Watt)

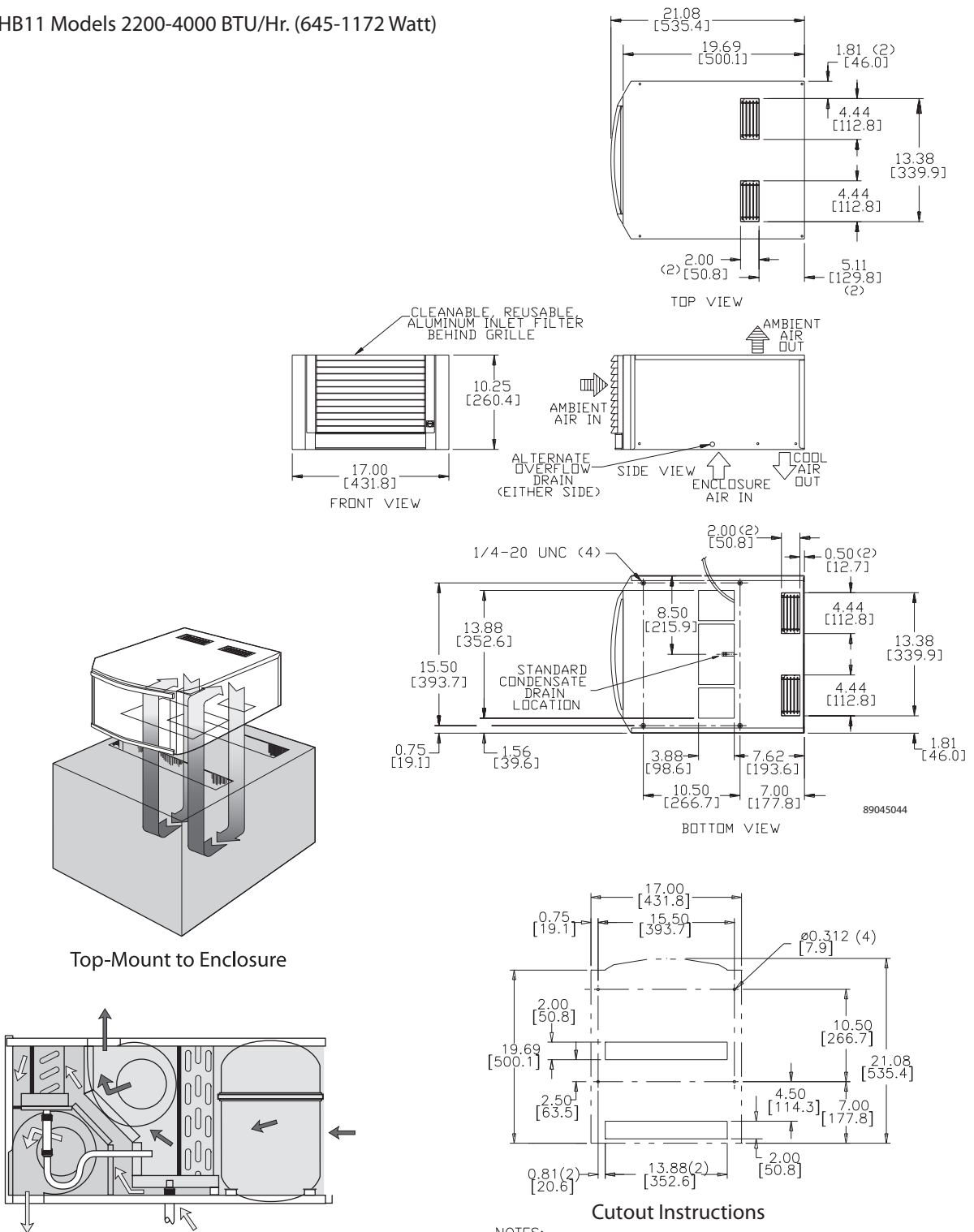

GENESIS A/C

Visit www.McLeanCoolingTech.com to download 2D and 3D CAD drawings into the overall design of your electronic system.

HB16 Top-Mount Air Conditioners



Industry Standards

UL/cUL Listed

- CE
- Type 12

Application

- Industrial automation
- Package handling equipment
- Security and defense systems
- Ideal for use where there is little or no clearance around the enclosure

Features

- Robust reciprocating compressor
- R407c earth-friendly refrigerant and RoHS compliant
- Models for 115, 230 and 460 single-phase AC volt power input
- UL Listed or Recognized to save customers time and money with agency approvals
- Operating temperature range from 50 F/10 C to 125 F/52 C
- Attractive industrial design with minimal use of visible fasteners
- Reliable mechanical thermostat located behind the filter of the unit
- Low-carbon mild-steel sheet-metal cover for rugged factory environments
- Cleanable, reusable aluminum mesh filter to protect coils for maximum cooling performance
- Mounting hardware, gaskets and user manual furnished with the unit
- Every unit functionally tested before shipping
- Standard Indoor Air Conditioner models also include:
 - Electro-Mechanical Thermostat
 - Surge Suppressor

Finish

- RAL 7042 gray, semi-gloss powder-coat paint standard
- Other colors and textures available

Options

- Thermostat Malfunction Package
- Special Voltage Package
 - * Consult the factory for availability and catalog number

Notes

Visit www.McLeanCoolingTech.com to download 2D and 3D CAD drawings into the overall design of your electronic system.

Performance Data **HB16 Models 8000 BTUs/Hr. (2051 W)**

MODEL NUMBER			
Indoor Model	HB160816G040	HB160826G040	HB160846G040
COOLING PERFORMANCE			
Nominal:			
BTUs/Hr.	7000/8000	7000/8000	7000/8000
Watts	2051/2344	2051/2344	2051/2344
At 125 F/125 F (52 C/52 C):			
BTUs/Hr. (50/60 Hz)	6975/8137	7075/8133	7075/8133
Watts (50/60 Hz)	2044/2385	2073/2384	2073/2384
At 95 F/95 F (35 C/35 C):			
BTUs/Hr. (50/60 Hz)	6959/8236	6958/7774	6958/7774
W (50/60 Hz)	2039/2414	2039/2278	2039/2278
Refrigerant	R-407C	R-407C	R-407C
Refrigerant Charge (ounces/grams)	24/680	24/680	24/680
Operating Temperature Range:			
Maximum (°F/°C)	125/52	125/52	125/52
Minimum (°F/°C)	50/10	50/10	50/10
ELECTRICAL DATA			
Rated Voltage	115	230	460
Frequency (Hertz)	50/60	50/60	50/60
Operating Range	+/- 10%	+/- 10%	+/- 10%
Max. Power Consumption (W at 50/60 Hz)	1822/2223	1785/2105	2162
Max. Nominal Current (A at 50/60 Hz)	18.7/20.4	8.5/9.3	4.3/4.7
Starting Current (A)	67	29	15
Agency Approvals	cUL Listed CE	cUL Listed CE	cUL Listed CE
Power Input Description	6-ft. cord with NEMA 5-20 plug	6-ft. cord with NEMA 6-20 plug	6-ft. cord with NEMA L8-20 plug
ENCLOSURE PROTECTION			
UL Type	Type 12		
CONTROLLER			
Description	Basic Mechanical Thermostat		
Thermostat Location	Enclosure Side on All Base Models		
Factory Thermostat Setting (°F/°C)	80/27	80/27	80/27
UNIT CONSTRUCTION			
Material	Galvanized Sheet Metal Standard (Optional: Stainless Steel)		
Finish	RAL 7042 gray, semi-gloss powder-coat paint standard Other colors and textures available		
UNIT DIMENSIONS			
Height (in./mm)	15.25/387.35	15.25/387.35	15.25/387.35
Width (in./mm)	17/431.8	17/431.8	17/431.8
Depth (in./mm)	25.1875/639.76	25.1875/639.76	25.1875/639.76
Weight (lb./kg)	145/69.78	145/69.78	145/69.78

GENESIS®

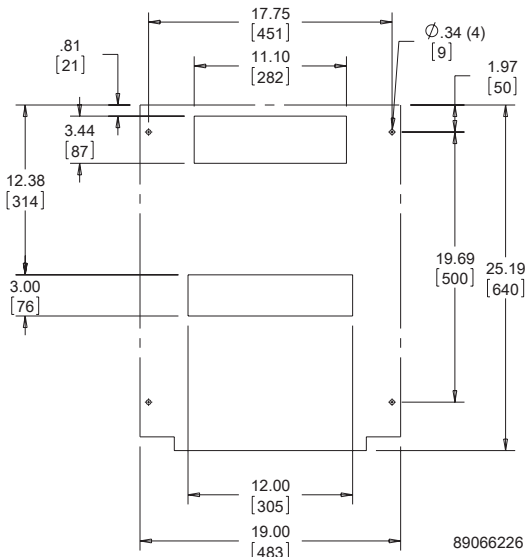
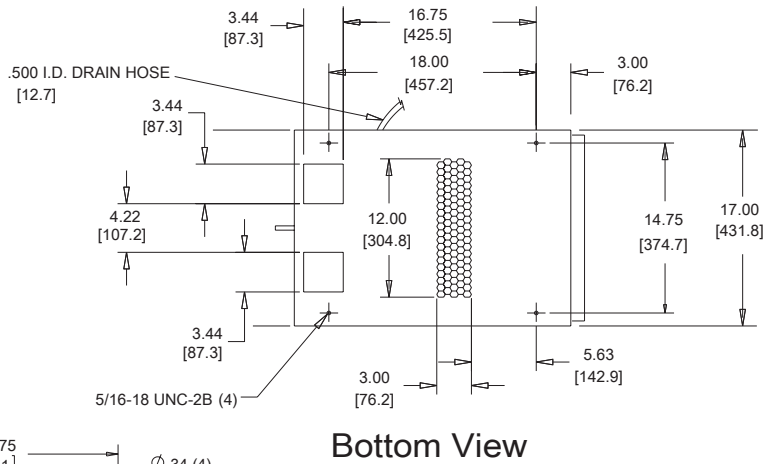
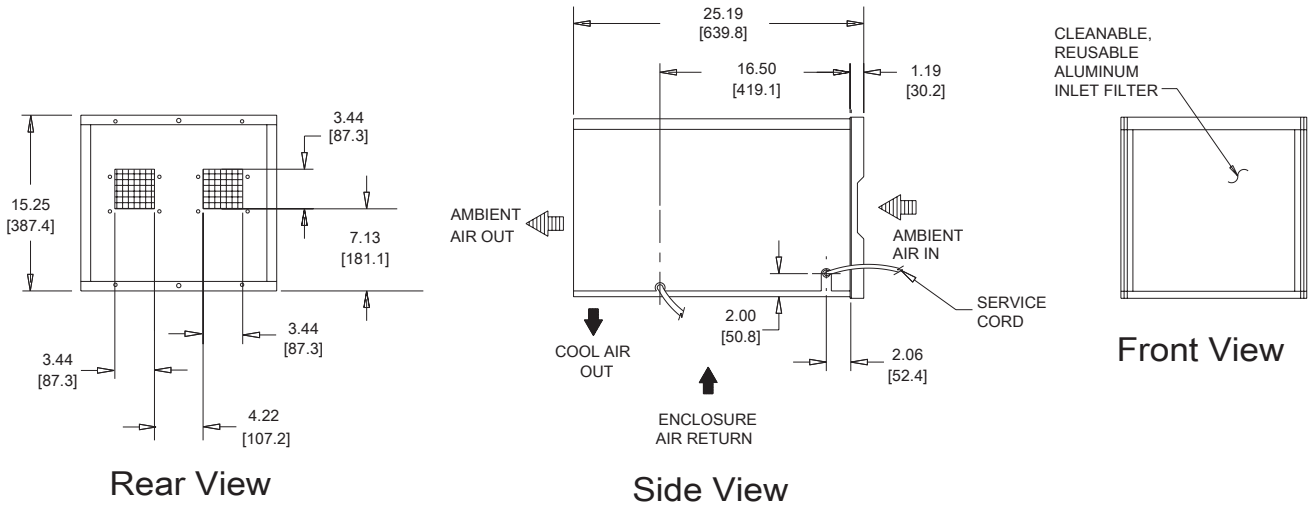

GENESIS A/C

Visit www.McLeanCoolingTech.com to download 2D and 3D CAD drawings into the overall design of your electronic system.

Notes

PROAIR Harsh Environment/Wash Down Air Conditioners



CR23



CR23st



CR29



CR43st

The ultimate in protective cooling for food & beverage, waste water & other applications



PROAIR Harsh Environment/ Wash Down Air Conditioners

PRODUCT OVERVIEW

Available in stainless steel and painted galvanized sheet metal options, the PROAIR Air Conditioner is engineered tough to seal out high-pressure hose water and withstand corrosive atmospheres.

APPLICATIONS

- Food and beverage process controls
- Wastewater treatment systems
- Other harsh environment applications

PROAIR Harsh Environment/ Wash Down Chapter Contents

Harsh Environment/Wash Down Air Conditioners	104
CR23 Model 1600 BTU.....	105
CR29 Model 2200/4000 BTU	108
CR43 Model 6000/8000 BTU.....	111

PROAIR

Harsh Environment/Wash Down Air Conditioners



CR23
1600 BTU/Hr.
469 Watts



CR29
2200 and 4000 BTU/Hr.
645 and 1172 Watts



CR43
6000 & 8000 BTU/Hr.
1758 and 2344 Watts

Industry Standards

UL/cUL Listed or UR/cUR Recognized

- CE
- Type 12/3R/4
- Type 4X stainless steel option

Application

- Industrial automation
- Package handling equipment
- Food and beverage
- Wastewater treatment
- Security and defense systems
- And more

Features

- Robust reciprocating compressor
- Maintenance made easy by front cover hinging open for quick access to all components; condenser coil can be cleaned while unit is still mounted to the cabinet
- R134a or R407c earth-friendly refrigerant and RoHS compliant
- Models for 115, 230 and 460 single phase AC volt power input
- UL Listed or Recognized to save customers time and money with agency approvals
- Operating temperature range from -40 F/-40 C to 131 F/55 C (with optional low-ambient package)
- Attractive industrial design with minimal use of visible fasteners
- Reliable mechanical thermostat located behind the filter of the unit. Indoor Air Conditioner models include digital display on ambient side.
- Low-carbon mild-steel sheet-metal cover for rugged factory and outdoor environments

- Easy-mount flanges for simple installation
- Cleanable reusable aluminum mesh filter to protect coils for maximum cooling performance
- Mounting hardware, gaskets and user manual furnished with the unit
- Every unit functionally tested before shipping
- High-performance fans and blowers designed for densely packed enclosures
- Standard Indoor Air Conditioner models also include:
 - Electro-Mechanical Thermostat
 - Surge Suppressor

Finish

- ANSI 70 gray, semi-gloss powder-coat paint standard
- Stainless steel Type 304 or 316 finishes available on Type 4X models
- Other colors and textures available

Options

- Thermostat Malfunction Package
 - Special Voltage Package
 - Outdoor Package*
 - Harsh Environment Package*
 - Stainless Steel Package*
 - Heater Package*
- * T-Series may be more appropriate. Refer to T-Series A/C chapter. Consult the factory for availability and catalog number.

Notes

Visit www.McLeanCoolingTech.com to download 2D and 3D CAD drawings into the overall design of your electronic system.

PROAIR

Performance Data **CR23 Models 1600 BTU/Hr. (469 W)**

CATALOG NUMBER			
	CR230216G002	CR230226G002	CR230246G400
COOLING PERFORMANCE			
Nominal:			
BTUs/Hr.	1400/1600	1400/1600	1400/1600
Watts	410/469	410/469	410/469
Refrigerant	R-134A	R-134A	R-134A
Refrigerant Charge (ounces/grams)	10/284	10/284	10/284
Operating Temperature Range:			
Maximum (°F/°C)	131/55	131/55	131/55
Minimum (°F/°C) (Low Ambient Pkg)	-40/-40	-40/-40	-40/-40
Airflow at 0 Static Pressure:			
Internal loop 50 Hz (CFM/m ³ /hr.)	117/199	117/199	117/199
External loop 50 Hz (CFM/m ³ /hr.)	86/146	86/146	86/146
Internal loop 60 Hz (CFM/m ³ /hr.)	130/221	130/221	130/221
External loop 60 Hz (CFM/m ³ /hr.)	95/161	95/161	95/161
ELECTRICAL DATA			
Rated Voltage	115	230	460V 1PH
Frequency (Hz)	50/60	50/60	50/60
Operating Range	+/- 10%	+/- 10%	+/- 10%
Max. Power Consumption (W at 50/60 Hz)	471.5/517.5	506	552
Max. Nominal Current (A at 50/60 Hz)	4.1/4.5	2.2	1.2
Starting Current (A)	18	8.5	5
Agency Approvals		cUL Listed CE	cUR Recognized CE
Power Input Description	6-ft. cord with NEMA 5-15 plug	6-ft. cord with NEMA 6-15 plug	6-ft. cord with wire leads
ENCLOSURE PROTECTION			
UL Type		Type 12/3R standard 4/4X Stainless steel optional	
CONTROLLER			
Description		Basic mechanical thermostat	
Thermostat Location		Behind cover	
Factory Thermostat Setting (°F/°C)		80/27	
SOUND LEVEL			
At 1.5 Meters		62 dB(A)	
UNIT CONSTRUCTION			
Material		Mild steel sheet metal standard Stainless steel optional	
Finish		ANSI 70 gray, semi-gloss powder-coat paint standard	
UNIT DIMENSIONS			
Height (in./mm)	23/584	23/584	23/584
Width (in./mm)	10/254	10/254	10/254
Depth (in./mm)	8.75/222	8.75/222	8.75/222
Weight (lb./kg)	57/26	57/26	67/30

PROAIR

CR23 Models 1600 BTU/Hr. (469 Watt)

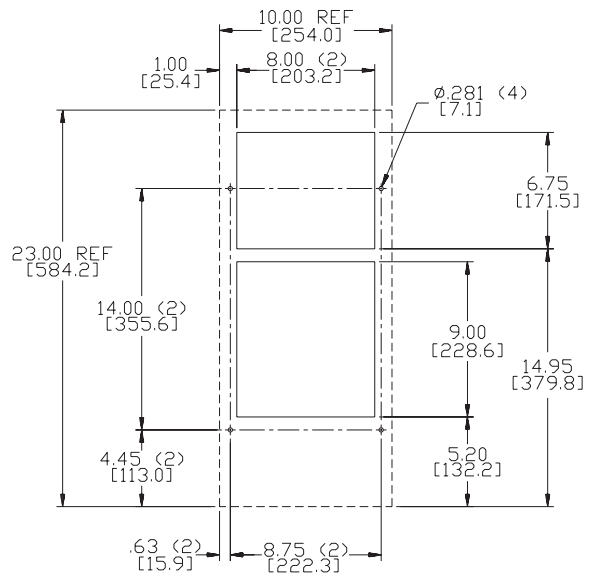
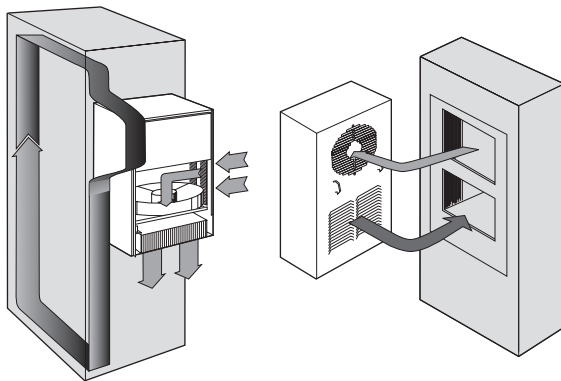
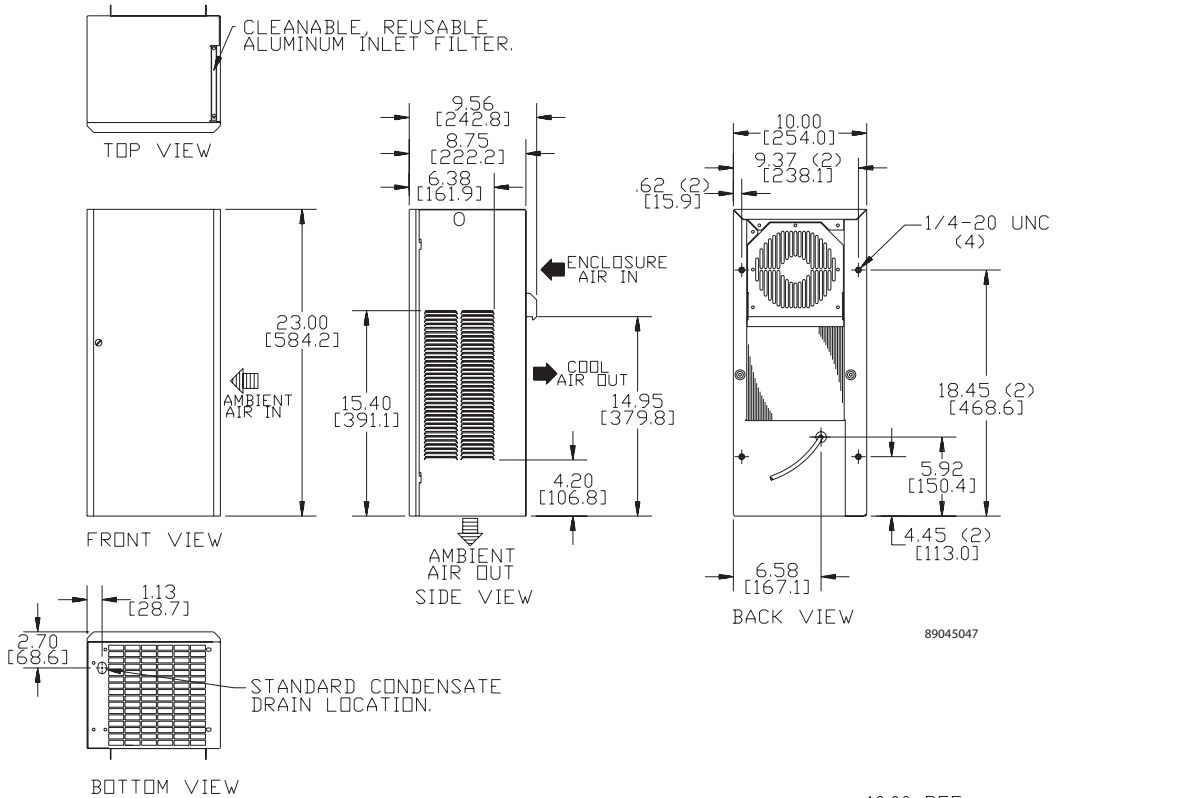

Cutout Instructions

NOTE:
1. DASHED LINES REPRESENT OUTSIDE OF AIR CONDITIONER.

Visit www.McLeanCoolingTech.com to download 2D and 3D CAD drawings into the overall design of your electronic system.

PROAIR

CR23 Models 1600 BTU/Hr. (469 Watt) With 4X Hood

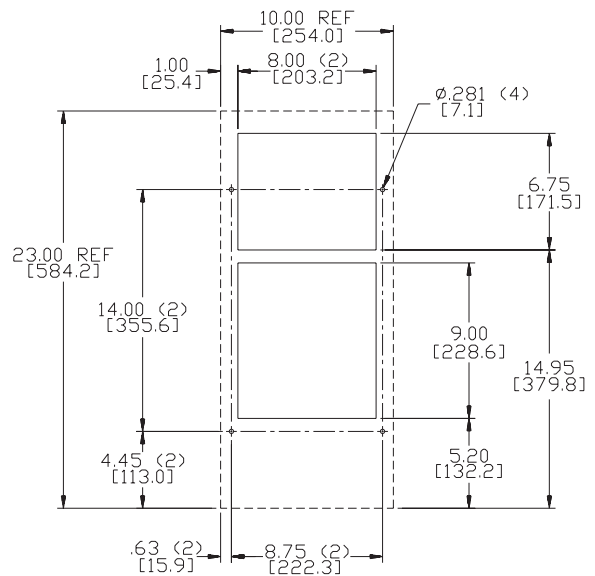
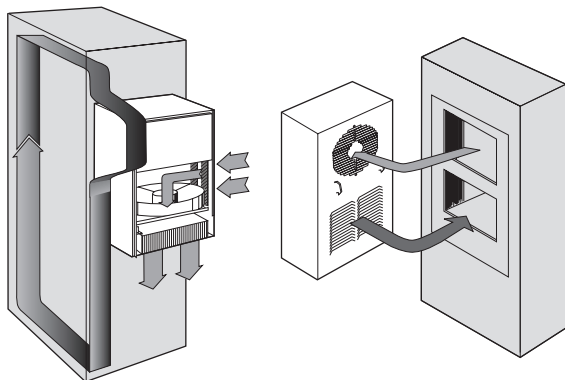
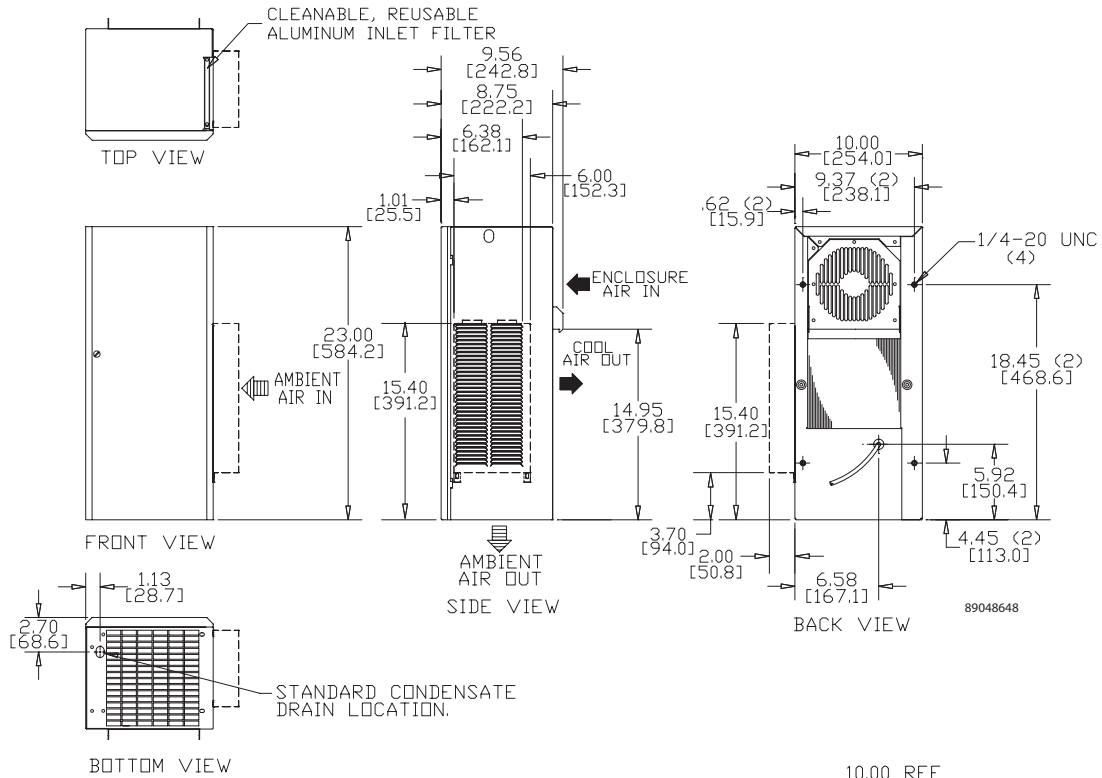

Cutout Instructions

NOTE:
1. DASHED LINES REPRESENT OUTSIDE OF AIR CONDITIONER.

Visit www.McLeanCoolingTech.com to download 2D and 3D CAD drawings into the overall design of your electronic system.

PROAIR A/C

PROAIR

Performance Data **CR29 Models 2200/4000 BTU/Hr. (645/1172 W)**

CATALOG NUMBER						
	CR290216G002	CR290226G002	CR290246G400	CR290416G002	CR290426G002	CR290446G400
COOLING PERFORMANCE						
Nominal:						
BTUs/Hr.	2000/2200	2500/2700	2500/2700	3500/4000	3500/4000	3500/4000
Watts	586/645	732/791	732/791	1025/1172	1025/1172	1026/1172
Refrigerant	R-134A	R-134A	R-134A	R-134A	R-134A	R-134A
Refrigerant Charge (ounces/grams)	11/312	11/312	11/312	12/341	12/341	12/341
Operating Temperature Range:						
Maximum (°F/°C)	131/55	131/55	131/55	131/55	131/55	131/55
Minimum (°F/°C) (Low Ambient Pkg)	-40/-40	-40/-40	-40/-40	-40/-40	-40/-40	-40/-40
Airflow at 0 Static Pressure:						
Internal loop 50 Hz (CFM/m ³ /hr.)	141/239	141/239	141/239	141/239	141/239	141/239
External loop 50 Hz (CFM/m ³ /hr.)	235/399	235/399	235/399	235/399	235/399	235/399
Internal loop 60 Hz (CFM/m ³ /hr.)	157/266	157/266	157/266	157/266	157/266	157/266
External loop 60 Hz (CFM/m ³ /hr.)	261/443	261/443	261/443	261/443	261/443	261/443
ELECTRICAL DATA						
Rated Voltage	115	230	460V 1PH	115	230	460V 1PH
Frequency (Hz)	50/60	50/60	50/60	50/60	50/60	50/60
Operating Range	+/- 10%	+/- 10%	+/- 10%	+/- 10%	+/- 10%	+/- 10%
Max. Power Consumption (W at 50/60 Hz)	851/517.5	1058/877	1150/996	1552.5	1541/1518	1702/1656
Max. Nominal Current (A at 50/60 Hz)	7.4	4.6/3.9	2.5/2.1	13.5/13.5	6.7/6.6	3.7/3.6
Starting Current (A)	28	14.4	7.4	48	23	12
Agency Approvals	cUL Listed CE		cUR Recognized CE	cUL Listed CE		cUR Recognized CE
Power Input Description	6-ft. cord with NEMA 5-15 plug	6-ft. cord with NEMA 6-15 plug	6-ft. cord with wire leads	6-ft. cord with NEMA 5-20 plug	6-ft. cord with NEMA 6-15 plug	6-ft. cord with wire leads
ENCLOSURE PROTECTION						
UL Type	Type 12/3R standard 4/4X Stainless steel optional			Type 12/3R standard 4/4X Stainless steel optional		
CONTROLLER						
Description	Basic mechanical thermostat			Basic mechanical thermostat		
Thermostat Location	Behind cover			Behind cover		
Factory Thermostat Setting (°F/°C)	80/27			80/27		
SOUND LEVEL						
At 1.5 Meters	68 dB(A)			68 dB(A)		
UNIT CONSTRUCTION						
Material	Mild steel sheet metal standard Stainless steel optional			Mild steel sheet metal standard Stainless steel optional		
Finish	ANSI 70 gray, semi-gloss powder-coat paint standard			ANSI 70 gray, semi-gloss powder-coat paint standard		
UNIT DIMENSIONS						
Height (in./mm)	29.5/749	29.5/749	29.5/749	29.5/749	29.5/749	29.5/749
Width (in./mm)	15.75/400	15.75/400	15.75/400	15.75/400	15.75/400	15.75/400
Depth (in./mm)	8.63/219	8.63/219	8.63/219	8.63/219	8.63/219	8.63/219
Weight (lb./kg)	98/44	98/44	108/49	118/54	118/54	128/58

PROAIR

CR29 Models 2200/4000 BTU/Hr. (645/1172 Watt)

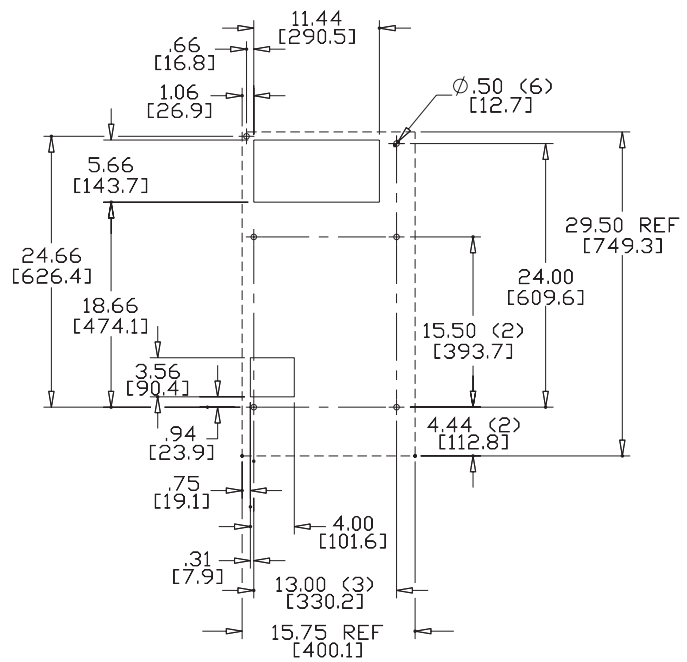
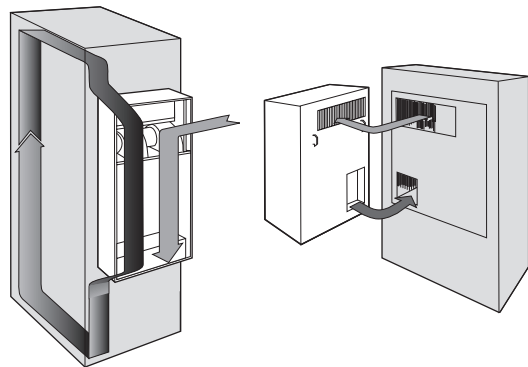
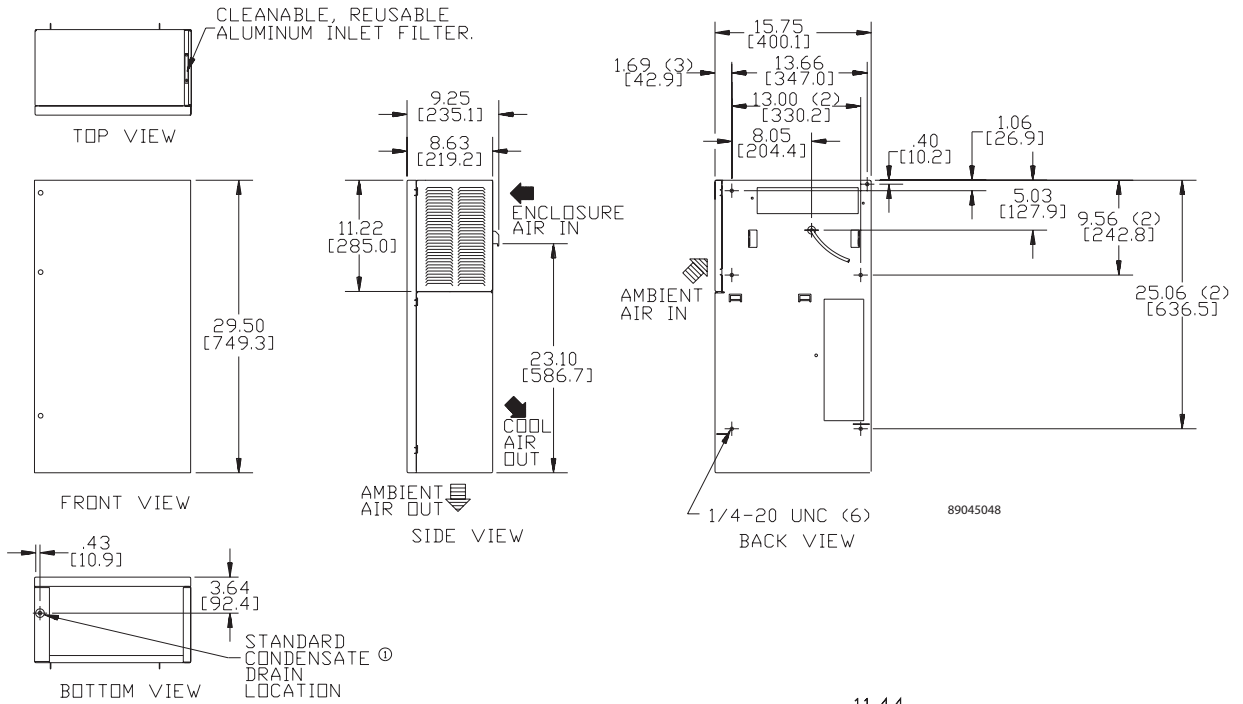

NOTE:

1. DASHED LINES REPRESENT OUTSIDE OF AIR CONDITIONER.

Visit www.McLeanCoolingTech.com to download 2D and 3D CAD drawings into the overall design of your electronic system.

PROAIR A/C

PROAIR

CR29 Models 2200/4000 BTU/Hr. (645/1172 Watt) With 4X Hood

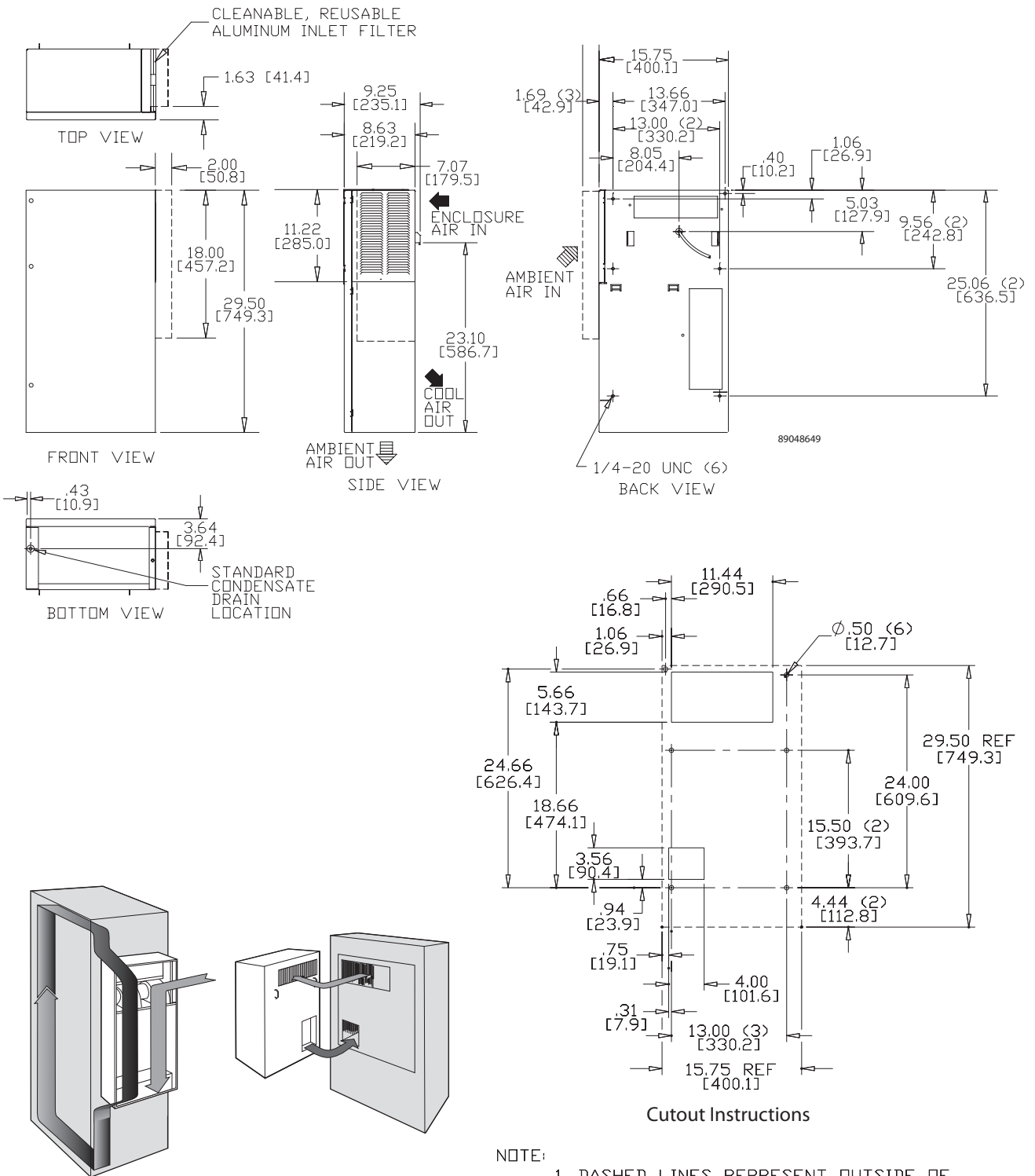

PROAIR A/C

Visit www.McLeanCoolingTech.com to download 2D and 3D CAD drawings into the overall design of your electronic system.

PROAIR

Performance Data **CR43 Models 6000/8000 BTU/Hr. (1758/2344 W)**

CATALOG NUMBER						
	CR430616G002	CR430626G002	CR430646G400	CR430816-G002	CR430826G002	CR430846G400
COOLING PERFORMANCE						
Nominal:						
BTUs/Hr.	5500/6000	5500/6000	5500/6000	7100/8000	7100/8000	7100/8000
Watts	1611/1758	1611/1758	1611/1758	2080/2344	2080/2344	2080/2344
Refrigerant	R-134A	R-134A	R-134A	R-134A	R-134A	R-134A
Refrigerant Charge (ounces/grams)	19/538	19/538	19/538	19/538	19/538	19/538
Operating Temperature Range:						
Maximum (°F/°C)	131/55	131/55	131/55	131/55	131/55	131/55
Minimum (°F/°C) (Low Ambient Pkg.)	-40/-40	-40/-40	-40/-40	-40/-40	-40/-40	-40/-40
Airflow at 0 Static Pressure:						
Internal loop 50 Hz (CFM/m ³ /hr.)	320/543	226/384	226/384	320/543	226/384	226/384
External loop 50 Hz (CFM/m ³ /hr.)	480/815	470/798	470/798	480/815	470/798	470/798
Internal loop 60 Hz (CFM/m ³ /hr.)	368/625	255/433	255/433	368/625	255/433	255/433
External loop 60 Hz (CFM/m ³ /hr.)	544/924	540/917	540/917	544/924	540/917	540/917
ELECTRICAL DATA						
Rated Voltage	115	230	460V 1PH	115	230	460V 1PH
Frequency (Hz)	50/60	50/60	50/60	50/60	50/60	50/60
Operating Range	+/- 10%	+/- 10%	+/- 10%	+/- 10%	+/- 10%	+/- 10%
Max. Power Consumption (W at 50/60 Hz)	1460	1403/1518	1564/1656	1460	1403/1518	1564/1656
Max. Nominal Current (A at 50/60 Hz)	12.7	6.1/6.6	3.4/3.6	12.7	6.1/6.6	3.4/3.6
Starting Current (A)	48.3	27	14	48.3	27	14
Agency Approvals	cUL Listed CE		cUR Recognized CE	cUL Listed CE		cUR Recognized CE
	Others available upon request			Others available upon request		
Power Input Description	6-ft. cord with NEMA 5-20 plug	6-ft. cord with NEMA 6-15 plug	6-ft. cord with wire leads	6-ft. cord with NEMA 5-20 plug	6-ft. cord with NEMA 6-15 plug	6-ft. cord with wire leads
ENCLOSURE PROTECTION						
UL Type	Type 12/3R standard 4/4X Stainless steel optional			Type 12/3R standard 4/4X Stainless steel optional		
CONTROLLER						
Description	Basic mechanical thermostat			Basic mechanical thermostat		
Thermostat Location	Enclosure side on all base models			Enclosure side on all base models		
Factory Thermostat Setting (°F/°C)	80/27			80/27		
SOUND LEVEL						
At 1.5 Meters	71 dB(A)			71 dB(A)		
UNIT CONSTRUCTION						
Material	Galvanized sheet metal standard Stainless steel optional			Galvanized sheet metal standard Stainless steel optional		
Finish	ANSI 70 gray, semi-gloss powder-coat paint standard			ANSI 70 gray, semi-gloss powder-coat paint standard		
UNIT DIMENSIONS						
Height (in./mm)	43/1092			43.31/1100		
Width (in./mm)	15.75/400			15.75/400		
Depth (in./mm)	10.9/279			10.25/260		
Weight (lb./kg)	125/57	125/57	155/70	125/57	125/57	155/70

PROAIR A/C

PROAIR

CR43 Models 6000/8000 BTU/Hr. (1758/2344 Watt)

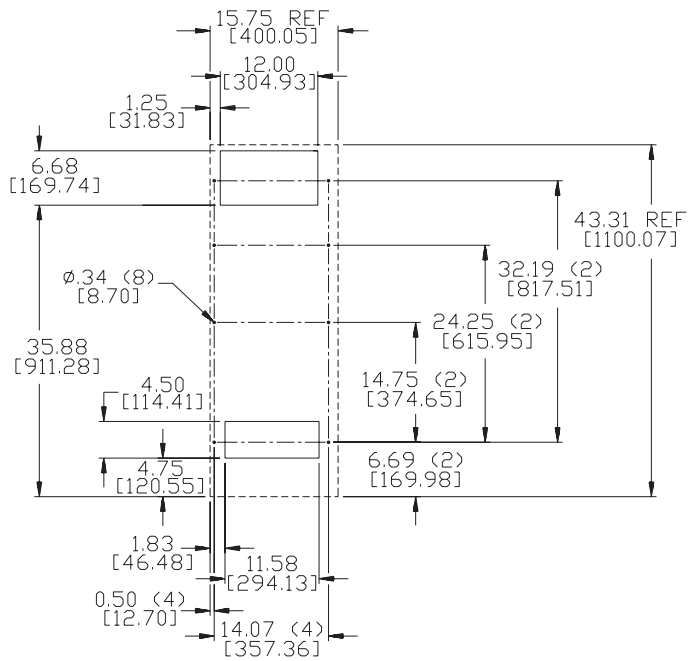
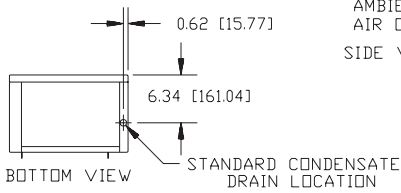
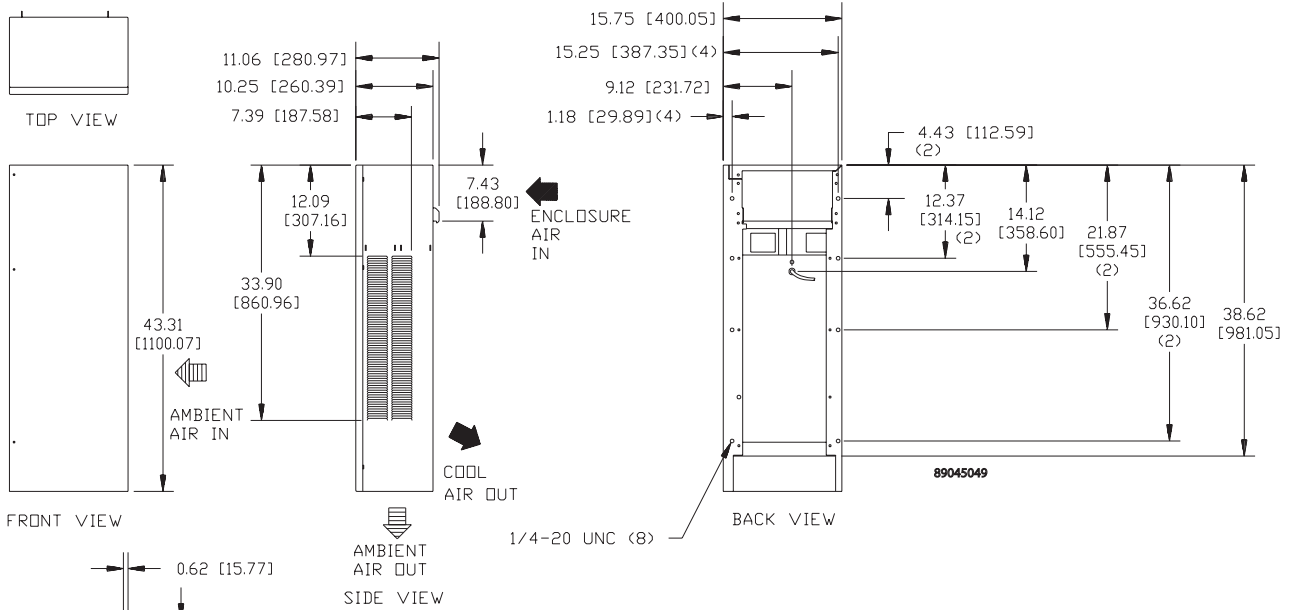

Cutout Instructions

NOTE: DASHED LINES REPRESENT OUTSIDE OF AIR CONDITIONER.

Visit www.McLeanCoolingTech.com to download 2D and 3D CAD drawings into the overall design of your electronic system.

PROAIR A/C

PROAIR

CR43 Models 6000/8000 BTU/Hr. (1758/2344 Watt) With 4X Hood

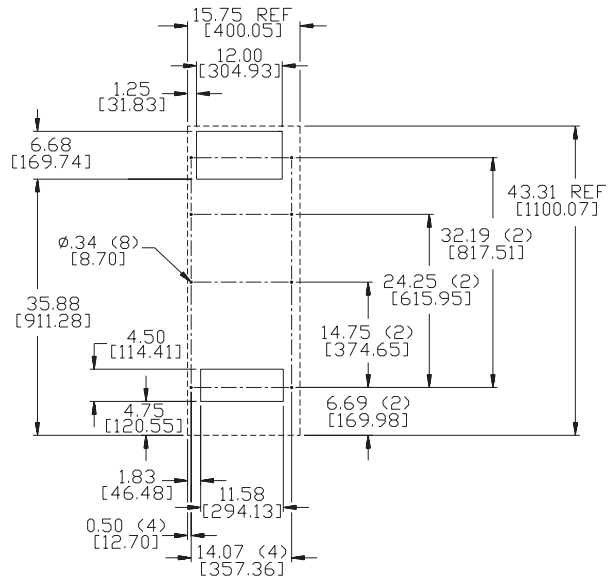
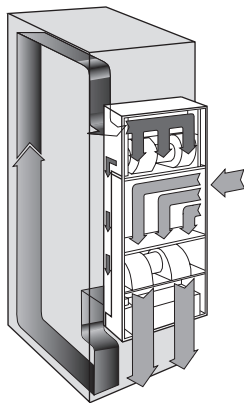
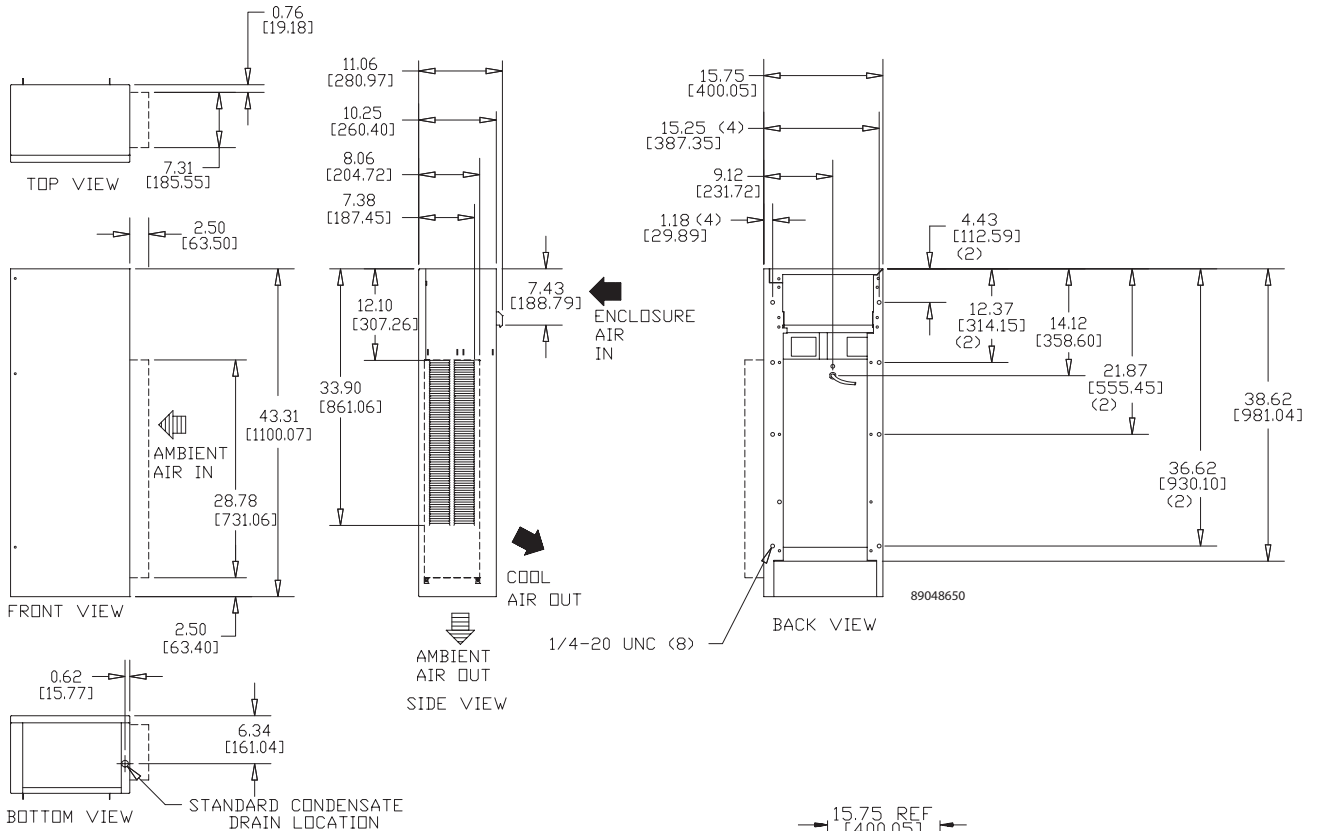

Cutout Instructions

NOTE: DASHED LINES REPRESENT OUTSIDE OF AIR CONDITIONER.

Visit www.McLeanCoolingTech.com to download 2D and 3D CAD drawings into the overall design of your electronic system.

PROAIR A/C

Water-Cooled Air Conditioners



33WC Model



CR43 Model



LB11WC Model

Effective electronics cooling for hot, dirty and hostile environments



Water-Cooled Air Conditioners

PRODUCT OVERVIEW

For highly effective temperature control when the electrical enclosure is in a hot, dirty or hostile environment. Requires chilled water at the enclosure.

APPLICATIONS

- High-temperature environments
- Extremely dusty and dirty conditions
- Other demanding applications

Water-Cooled Chapter Contents

Water-Cooled Air Conditioners	116
33WC Model 4000 BTU	117
CR43WC Model 8000 BTU	119
LB11WC Model 4000 BTU	121

Water-Cooled Air Conditioners



33WC
4000 BTU/Hr.
(1172 Watt) Models



CR43WC
8000 BTU/Hr.
(2345 Watt) Models



LB11WC
4000 BTU/Hr.
(1172 Watt) Models

Industry Standards

UL/cUL Listed or UR/cUR Recognized

- CE
- Type 12 on 33 water-cooled models
- Type 4/4X stainless steel option on CR water-cooled models

Application

- Industrial automation
- Package handling equipment
- Food and beverage
- Wastewater treatment
- Security and defense systems
- Pulp and paper
- And more

Features

- Robust reciprocating compressor
- R134a earth-friendly refrigerant and RoHS compliant
- Models for 115 and 230 AC volt power input
- UL Listed or Recognized to save customers time and money with agency approvals
- Operating temperature range from 50 F/10 C to 125 F/52 C
- Attractive industrial design with minimal use of visible fasteners
- Reliable mechanical thermostat located behind the front panel of the unit
- Low-carbon mild-steel sheet-metal cover for rugged factory and outdoor environments
- Easy-mount flanges for simple installation

- Mounting hardware, gaskets and user manual furnished with the unit
- Every unit functionally tested before shipping
- Heat is removed from the system by means of the water cooling the refrigerant. No external air movers or condenser coils to get clogged.
- Maximum water usage of 2 GPM at 90 F water intake temperature
- Standard Indoor Air Conditioner models also include:
 - Electro-Mechanical Thermostat
 - Surge Suppressor

Finish

- RAL 7042 gray, semi-gloss powder-coat paint standard
- Stainless steel Type 304 or 316 finishes available on Type 4X models
- Other colors and textures available

Options

- Thermostat Malfunction Package
- Special Voltage Package
- Active Condensate Evaporator Package
- Harsh Environment Package*
- Stainless Steel Package*
 - * Consult the factory for availability and catalog number.

Notes

Visit www.McLeanCoolingTech.com to download 2D and 3D CAD drawings into the overall design of your electronic system.

Water-Cooled

Performance Data 33WC Models 4000 BTU/Hr. (1172 W)

CATALOG NUMBER	330416GW010	330426GW014	330426GW012
COOLING PERFORMANCE			
Nominal:			
BTUs/Hr.	3800/4000	3800/4000	3800/4000
Watts	1113/1172	1113/1172	1113/1172
Refrigerant	R-134A	R-134A	R-134A
Refrigerant Charge (ounces/grams)	7/198	7/198	7/198
Operating Temperature Range:			
Maximum (°F/°C)	125/52	125/52	125/52
Minimum (°F/°C)	50/10	50/10	50/10
Airflow at 0 Static Pressure:			
Internal loop 50 Hz (CFM/m ³ /hr.)	135/229	100/170	100/170
External loop 50 Hz	Waterflow: 0.5 GPM @ 90 F	Waterflow: 0.5 GPM @ 90 F	Waterflow: 0.5 GPM @ 90 F
Internal loop 60 Hz (CFM/m ³ /hr.)	145/246	110/187	110/187
External loop 60 Hz	Waterflow: 0.5 GPM @ 90 F	Waterflow: 0.5 GPM @ 90 F	Waterflow: 0.5 GPM @ 90 F
ELECTRICAL DATA			
Rated Voltage	115	220/230	460V 1PH
Frequency (Hz)	50/60	50/60	50/60
Operating Range	+/- 10%	+/- 10%	+/- 10%
Max. Power Consumption (W at 50/60 Hz)	690/667	726/736	828/782
Max. Nominal Current (A at 50/60 Hz)	6.0/5.8	3.3/3.2	1.8/1.7
Starting Current (A)	28	14.4	7.4
Agency Approvals	cUL Listed CE	cUL Listed CE	cUR Recognized CE
Power Input Description	6-ft. cord with NEMA 5-15 plug	6-ft. cord with NEMA 6-15 plug	6-ft. cord with wire leads
ENCLOSURE PROTECTION			
UL Type	Type 12 standard		
CONTROLLER			
Description	Basic mechanical thermostat		
Thermostat Location	Behind front cover		
Factory Thermostat Setting (°F/°C)	80/27		
SOUND LEVEL			
At 1.5 Meters	61 dB(A)		
UNIT CONSTRUCTION			
Material	Mild steel sheet metal standard Stainless steel optional		
Finish	RAL 7042 gray, semi-gloss powder-coat paint standard		
UNIT DIMENSIONS			
Height (in./mm)	34.13/867	34.13/867	38.63/981.2
Width (in./mm)	12.38/314	12.38/314	12.38/314
Depth (in./mm)	8.75/222	8.75/222	8.75/222
Weight (lb./kg)	86/39	86/39	106/48

33WC Models 4000 BTU/Hr. (1172 Watt)

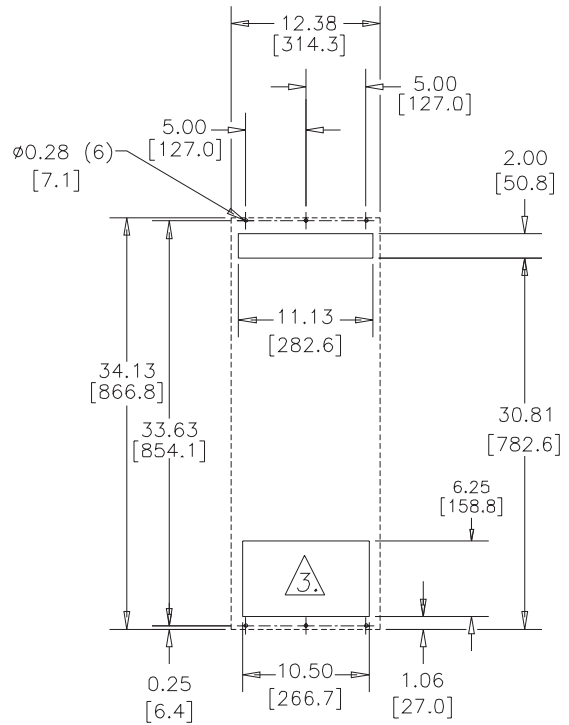
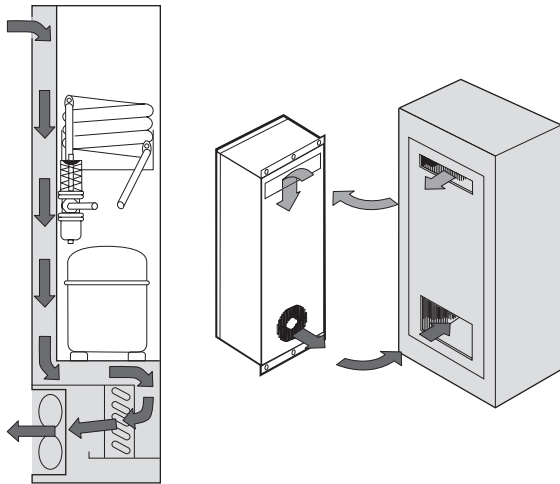
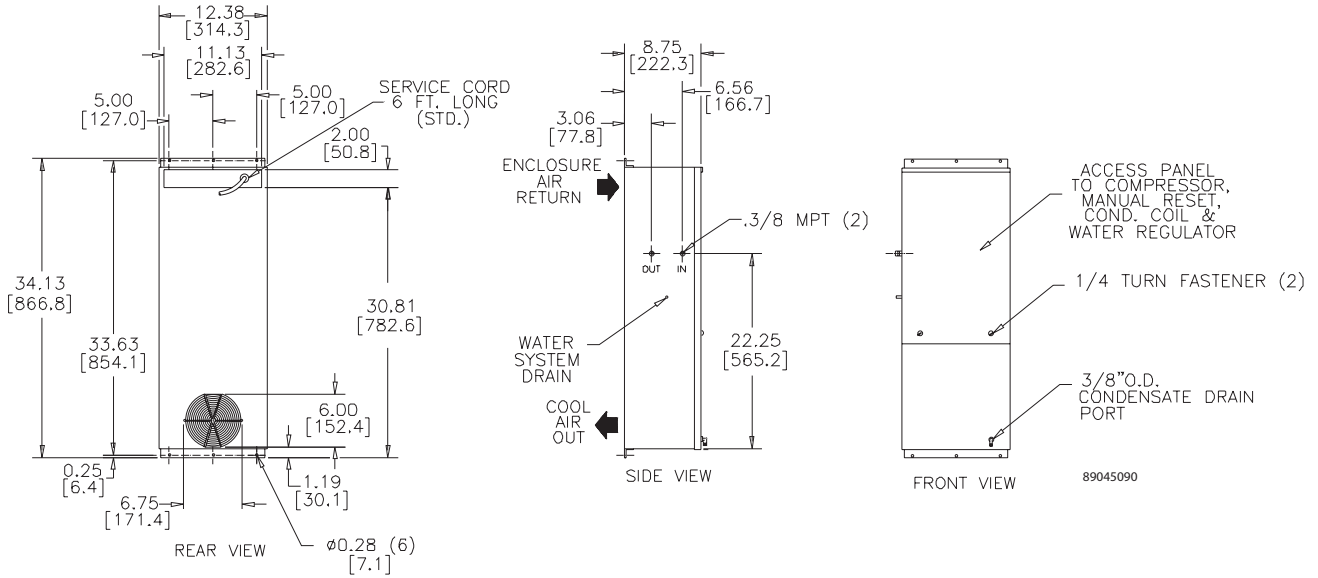

Cutout Instructions

Visit www.McLeanCoolingTech.com to download 2D and 3D CAD drawings into the overall design of your electronic system.

Water-Cooled

Performance Data CR43WC Models 8000 BTU/Hr. (2345 W)

CATALOG NUMBER		
	CR430816GW010	CR430826GWXXX
COOLING PERFORMANCE		
Nominal:		
BTUs/Hr.	8500	8500
Watts	2490	2490
Refrigerant	R-134A	R-134A
Refrigerant Charge (ounces/grams)	12/341	12/341
Operating Temperature Range:		
Maximum (°F/°C)	131/55	131/55
Minimum (°F/°C)	50/10	50/10
Airflow at 0 Static Pressure:		
Internal loop 50 Hz (CFM/m ³ /hr.)	135/229	100/170
External loop 50 Hz	Waterflow: 1.5 GPM @ 90F	Waterflow: 1.5 GPM @ 90F
Internal loop 60 Hz (CFM/m ³ /hr.)	145/246	110/187
External loop 60 Hz	Waterflow: 1.5 GPM @ 90F	Waterflow: 1.5 GPM @ 90F
ELECTRICAL DATA		
Rated Voltage	115	230
Frequency (Hz)	50/60	50/60
Operating Range	+/- 10%	+/- 10%
Max. Power Consumption (W at 50/60 Hz)	1518/1495	1518/1495
Max. Nominal Current (A at 50/60 Hz)	13.2/13	6.6/6.5
Starting Current (A)	48.3	27
Agency Approvals		cUL Listed CE
Power Input Description	6-ft. cord with NEMA 5-15 plug	6-ft. cord with NEMA 6-15 plug
ENCLOSURE PROTECTION		
UL Type	Type 4 standard	
CONTROLLER		
Description	Basic mechanical thermostat	
Thermostat Location	Behind front cover	
Factory Thermostat Setting (°F/°C)	80/27	
SOUND LEVEL		
At 1.5 Meters	61 dB(A)	
UNIT CONSTRUCTION		
Material	Mild steel sheet metal standard Stainless steel optional	
Finish	RAL 7042 gray, semi-gloss powder-coat paint standard	
UNIT DIMENSIONS		
Height (in./mm)	43.31/1100	
Width (in./mm)	15.75/400	
Depth (in./mm)	10.25/260.4	
Weight (lb./kg)	86/39	

CR43WC Models 8000 BTU/Hr. (2345 Watt)

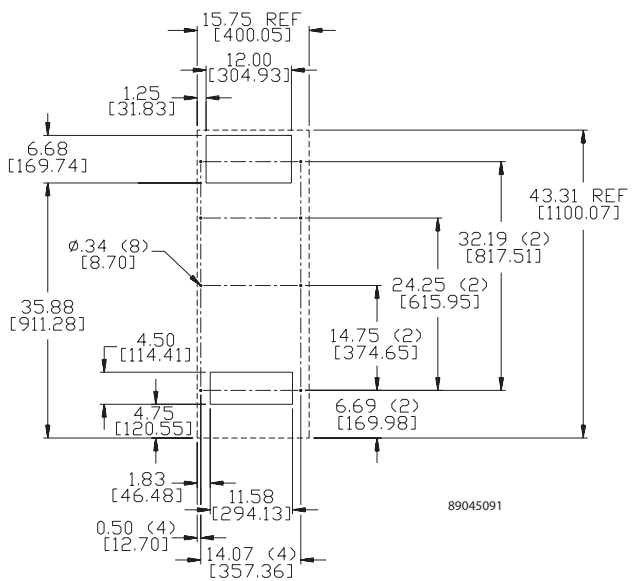
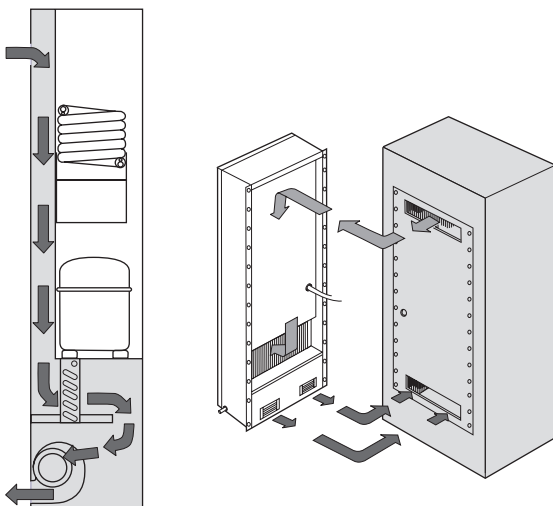
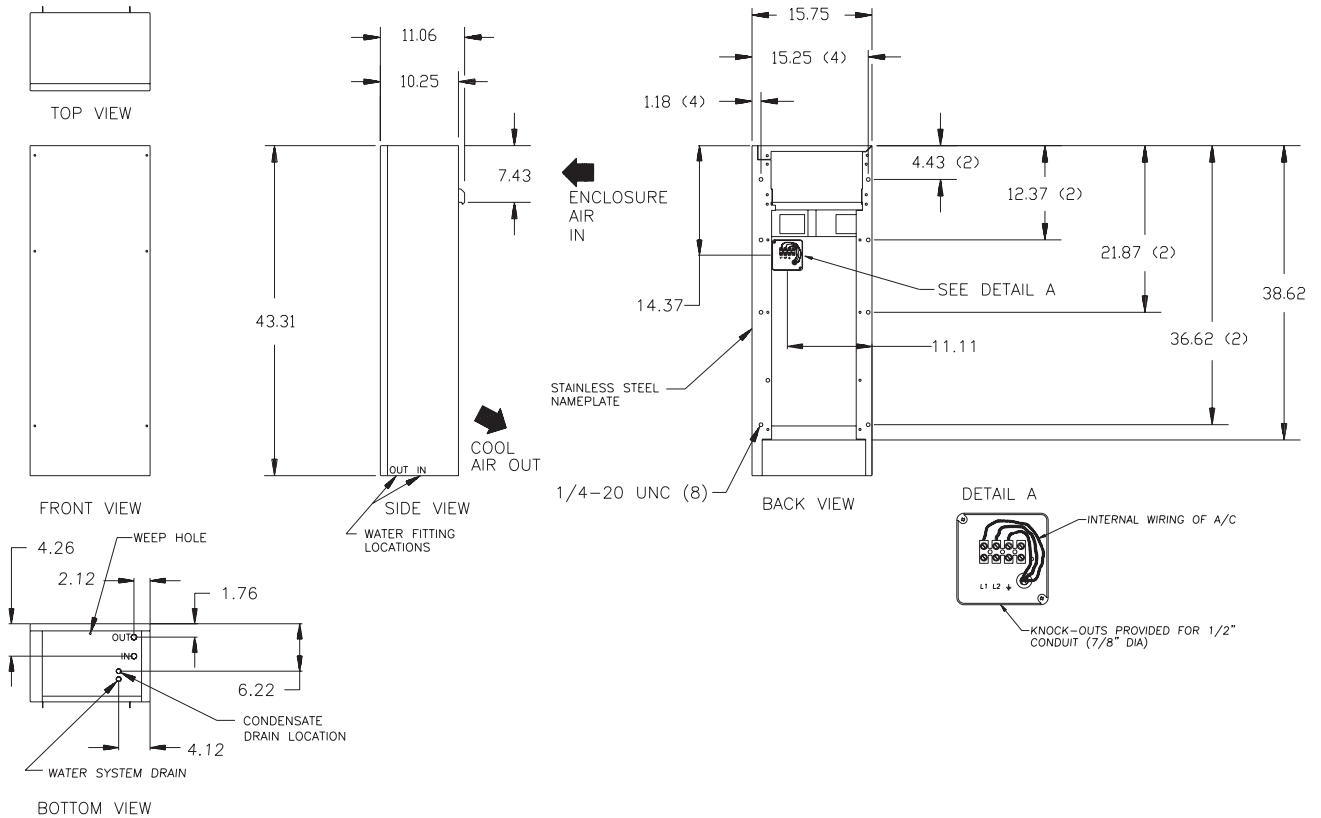

Cutout Instructions

Visit www.McLeanCoolingTech.com to download 2D and 3D CAD drawings into the overall design of your electronic system.

Water-Cooled

Performance Data LB11WC Models 4000 BTU/Hr (1172 W)

CATALOG NUMBER		
	LB110416GW008	LB110426GW010
COOLING PERFORMANCE		
Nominal:		
BTUs/Hr.	3900/4000	3900/4000
Watts	1142/1172	1142/1172
Refrigerant	R-134A	R-134A
Refrigerant Charge (ounces/grams)	12/340	12/340
Operating Temperature Range:		
Maximum (°F/°C)	125/52	125/52
Minimum (°F/°C)	50/10	50/10
Airflow at 0 Static Pressure:		
Internal loop 50 Hz (CFM/m ³ /hr.)	135/229	100/170
External loop 50 Hz	Waterflow: 1.0 GPM @ 90 F	Waterflow: 1.0 GPM @ 90 F
Internal loop 60 Hz (CFM/m ³ /hr.)	145/246	110/187
External loop 60 Hz	Waterflow: 1.0 GPM @ 90 F	Waterflow: 1.0 GPM @ 90 F
ELECTRICAL DATA		
Rated Voltage	115	230
Frequency (Hz)	50/60	50/60
Operating Range	+/- 10%	+/- 10%
Max. Power Consumption (W at 50/60 Hz)	885.5/828	897/792
Max. Nominal Current (A at 50/60 Hz)	7.7/7.2	3.9/3.6
Starting Current (A)	28	14.4
Agency Approvals	Not listed	cUL Listed CE
Power Input Description	6-ft. cord with NEMA 5-15 plug	6-ft. cord with NEMA 6-15 plug
ENCLOSURE PROTECTION		
UL Type	Type 12 standard	
CONTROLLER		
Description	Basic mechanical thermostat	
Thermostat Location	Behind front cover	
Factory Thermostat Setting (°F/°C)	80/27	
SOUND LEVEL		
At 1.5 Meters	61 dB(A)	
UNIT CONSTRUCTION		
Material	Mild steel sheet metal standard Stainless steel optional	
Finish	RAL 7042 gray, semi-gloss powder-coat paint standard	
UNIT DIMENSIONS		
Height (in./mm)	10.47/266	10.47/265.9
Width (in./mm)	19/483	19/482.6
Depth (in./mm)	19.63/499	19.63/498.5
Weight (lb./kg)	110/50	110/50

Water-Cooled

LB11WC Models 4000 BTU/Hr. (1172 Watt)

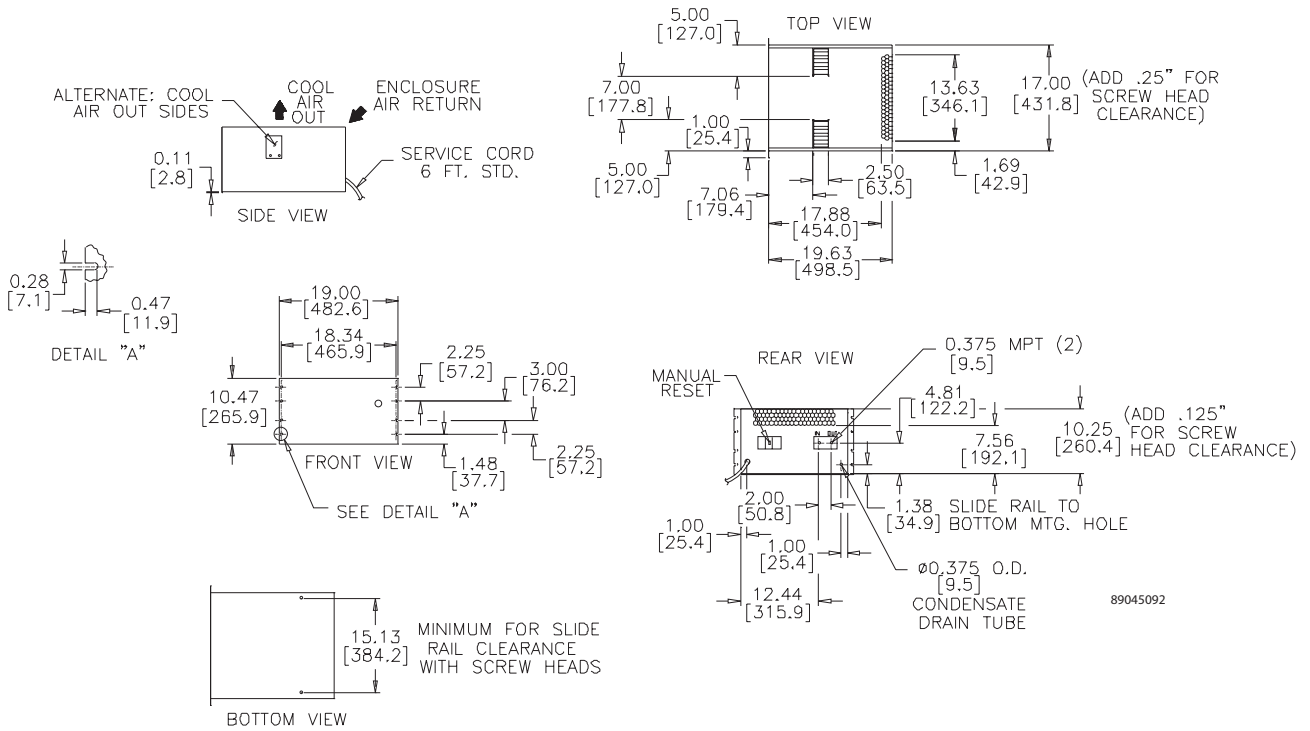

Cutout Instructions

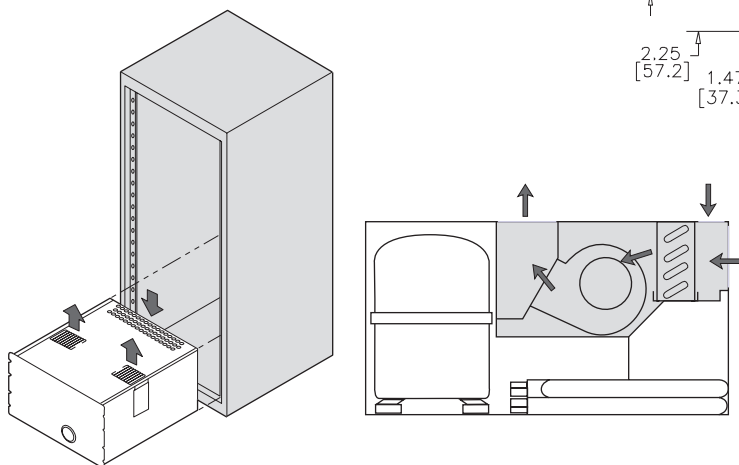

Visit www.McLeanCoolingTech.com to download 2D and 3D CAD drawings into the overall design of your electronic system.

Notes

PROAIR Indoor Heat Exchangers



XR20 Model



ZR29-18 Model



XR47-24 Model



XR60-84 Model

Time-proven reliability and low-maintenance design for trouble-free cooling



PROAIR Indoor Heat Exchangers

PRODUCT OVERVIEW

Keep your industrial process control equipment cool with this highly reliable Type 12 heat exchanger built for low-maintenance operation. Every unit is able to operate without a filter.

APPLICATIONS

- Industrial drive enclosures
- Automotive assembly systems
- Material handling applications
- Other process control systems

PROAIR Indoor Heat Exchangers Chapter Contents

Indoor Heat Exchangers.....	126
XR20 Model.....	127
XR29-08 Model	129
XR29-18 Model	131
XR47-24 Model	133
XR47-35 Model	135
XR60-55 Model	137
XR60-84 Model	139

PROAIR Indoor Heat Exchangers

Indoor Heat Exchangers

PROAIR HEX



XR20	XR29-08	XR29-18	XR47-24	XR47-35	XR60-55	XR60-84
Models	Models	Models	Models	Models	Models	Models
4 W/°F (7 W/°C)	8 W/°F (14 W/°C)	18 W/°F (32 W/°C)	24 W/°F (43 W/°C)	35 W/°F (63 W/°C)	55 W/°F (99 W/°C)	84 W/°F (151 W/°C)

Industry Standards

UL/cUL Listed or UR/cUR Recognized

- CE
- Type 12 on XR20 and XR29-08 models
- Type 3R on XR29-18 and larger models when surface mounted vertically on an enclosure

Application

- Industrial automation
- Package handling equipment
- Security and defense systems
- And more

Features

- Unique counterflow aluminum core for high-efficiency and high-performance heat transfer, except for the XR20 and XR29-08 which use a modified heat pipe core
- Models for 115 and 230 AC volt power input
- UL Listed or Recognized to save customers time and money with agency approvals
- Operating temperature range from -20 F/-29 C to 140 F/60 C
- Streamlined aesthetics with no visible mounting rails. Slim design allows for mounting to narrow or shallow enclosures.
- Reliable top-quality bearing fans and impellers make these units run quietly and with increased reliability
- Low-carbon mild-steel sheet-metal cover for rugged factory environments
- Easy-mount flanges for simple installation
- Mounting hardware, gaskets and user manual furnished with the unit
- Every unit functionally tested before shipping
- Filterless design for low maintenance and easy cleaning
- Four fasteners allow simple removal of front cover for easy access

Finish

- RAL 7035 light-gray, semi-textured powder-coat paint standard
- Stainless steel Type 304 or 316 finishes available on Type 4X models
- Other colors and textures available

Options

- Special Voltage Package
- Outdoor Package*
- Harsh Environment Package*
- Stainless Steel Package*
 - * CLIMAGUARD™ may be more appropriate. Refer to CLIMAGUARD HEX chapter. Consult the factory for availability and catalog number.

Notes

Visit www.McLeanCoolingTech.com to download 2D and 3D CAD drawings into the overall design of your electronic system

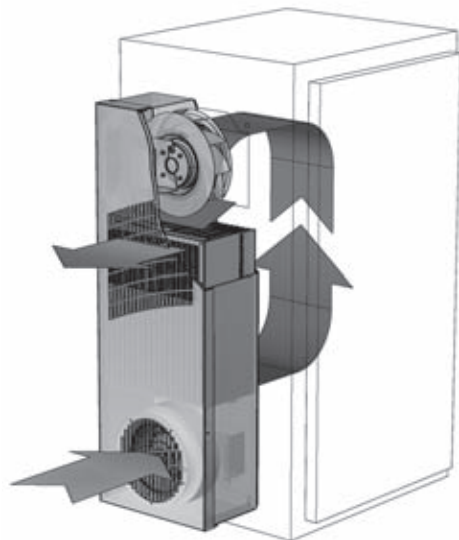

Performance Data **XR20 Models 4 W/°F (7 W/°C)**

CATALOG NUMBER		
	XR200416012	XR200426012
COOLING PERFORMANCE		
Nominal:		
W per °F	4	4
W per °C	7	7
Refrigerant	R-134A	R-134A
Refrigerant Charge (ounces/grams)	4/113	4/113
Operating Temperature Range:		
Maximum (°F/°C)	140/60	140/60
Minimum (°F/°C)	-20/-29	-20/-29
Airflow at 0 Static Pressure:		
Internal loop 50 Hz (CFM/m ³ /hr.)	71/121	71/121
External loop 50 Hz (CFM/m ³ /hr.)	75/127	75/127
Internal loop 60 Hz (CFM/m ³ /hr.)	74/126	74/126
External loop 60 Hz (CFM/m ³ /hr.)	78/132	78/132
ELECTRICAL DATA		
Rated Voltage	115	230
Frequency (Hz)	50/60	50/60
Operating Range	+/- 10%	+/- 10%
Max. Power Consumption (W at 50/60 Hz)	69	69
Max. Nominal Current (A at 50/60 Hz)	0.6	0.3
Agency Approvals	cUL Listed CE	
Power Input Description	6-ft. cord with NEMA 5-15 plug	6-ft. cord with NEMA 6-15 plug
ENCLOSURE PROTECTION		
UL Type	Type 12 standard	
SOUND LEVEL		
At 1.5 Meters	56 dBA	
UNIT CONSTRUCTION		
Material	Mild steel sheet metal standard Stainless steel optional	
Finish	RAL 7035 light-gray, semi-textured powder-coat paint standard	
UNIT DIMENSIONS		
Height (in./mm)	20/508	20/508
Width (in./mm)	7.5/190.5	7.5/190.5
Depth (in./mm)	3/76.2	3/76.2
Weight (lb./kg)	12/5.4	12/5.4

Mounting Options

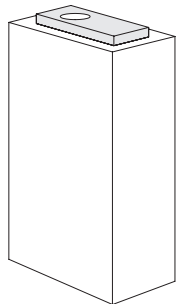

External Top-Mount

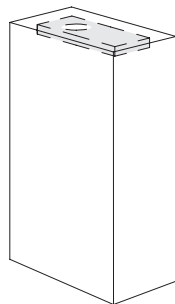

Internal Top-Mount

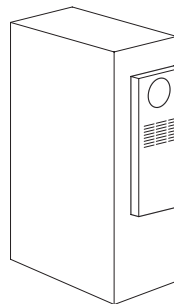

External Vertical-Mount

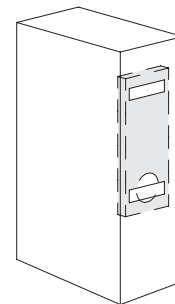

Internal Vertical-Mount

Note:
Internal mounting requires inverting the heat exchanger as shown.

87569532

PROAIR Indoor Heat Exchangers

XR20 Models 4 W/°F (7 W/°C)

PROAIR HEX

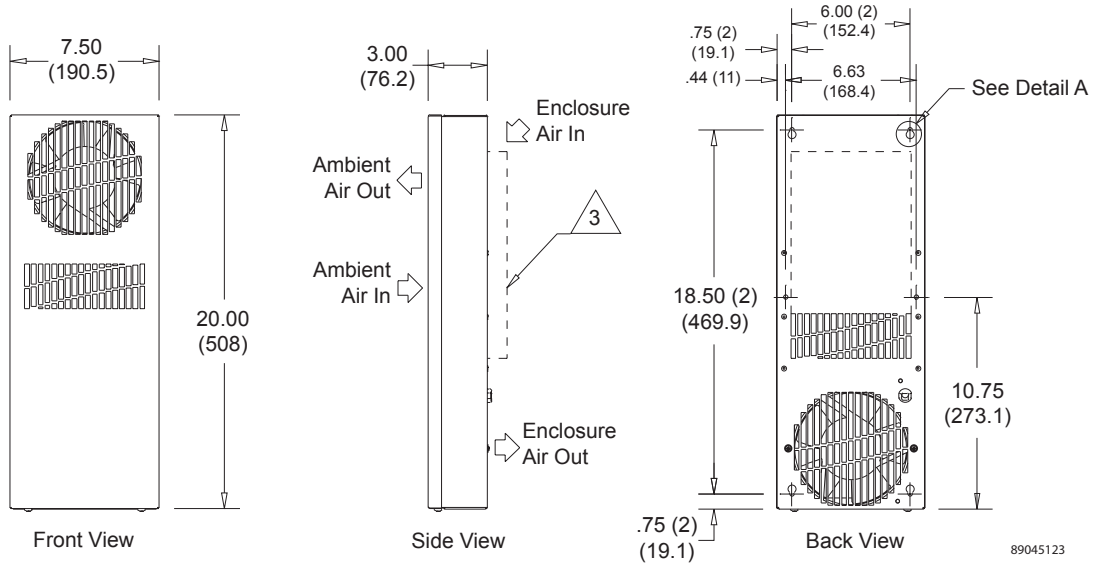

89045123

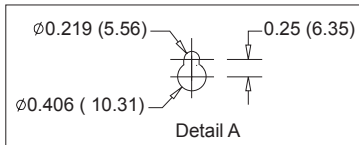

Note:

1. Supplied with mounting gasket kit.
2. Service cord terminated with appropriate plug:
NEMA 5-15P for 115V units
NEMA 6-15P for 230V units
3. Detachable airflow plenum may be used when mounting the heat exchanger inside or outside of the enclosure.

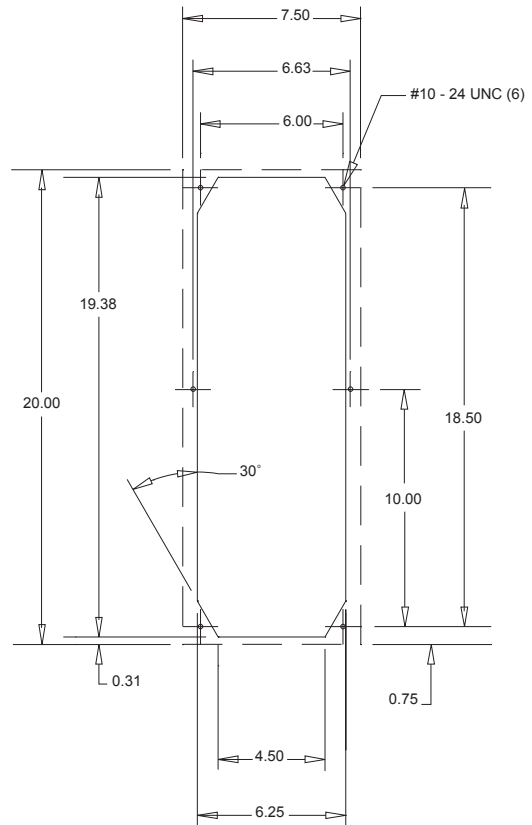

Cutout Instructions

Visit www.McLeanCoolingTech.com to download 2D and 3D CAD drawings into the overall design of your electronic system.

Performance Data **XR29 Models 8 W/°F (14 W/°C)**

CATALOG NUMBER		
	XR290816012	XR290826012
COOLING PERFORMANCE		
Nominal:		
W per °F	8	8
W per °C	14	14
Refrigerant	R-134A	R-134A
Refrigerant Charge (ounces/grams)	5.5/156	5.5/156
Operating Temperature Range:		
Maximum (°F/°C)	140/60	140/60
Minimum (°F/°C)	-20/-29	-20/-29
Airflow at 0 Static Pressure:		
Internal loop 50 Hz (CFM/m ³ /hr.)	71/121	71/121
External loop 50 Hz (CFM/m ³ /hr.)	75/127	75/127
Internal loop 60 Hz (CFM/m ³ /hr.)	74/126	74/126
External loop 60 Hz (CFM/m ³ /hr.)	78/132	78/132
ELECTRICAL DATA		
Rated Voltage	115	230
Frequency (Hz)	50/60	50/60
Operating Range	+/- 10%	+/- 10%
Max. Power Consumption (W at 50/60 Hz)	69	69
Max. Nominal Current (A at 50/60 Hz)	0.6	0.3
Agency Approvals	cUL Listed CE	
Power Input Description	6-ft. cord with NEMA 5-15 plug	6-ft. cord with NEMA 6-15 plug
ENCLOSURE PROTECTION		
UL Type	Type 12 standard	
SOUND LEVEL		
At 1.5 Meters	56 dBA	
UNIT CONSTRUCTION		
Material	Mild steel sheet metal standard Stainless steel optional	
Finish	RAL 7035 light-gray, semi-textured powder-coat paint standard	
UNIT DIMENSIONS		
Height (in./mm)	29.5/749.3	29.5/749.3
Width (in./mm)	10/254	10/254
Depth (in./mm)	3.09/78.5	3.09/78.5
Weight (lb./kg)	21/9.5	21/9.5

XR29 Models 8 W/°F (14 W/°C)

PROAIR HEX

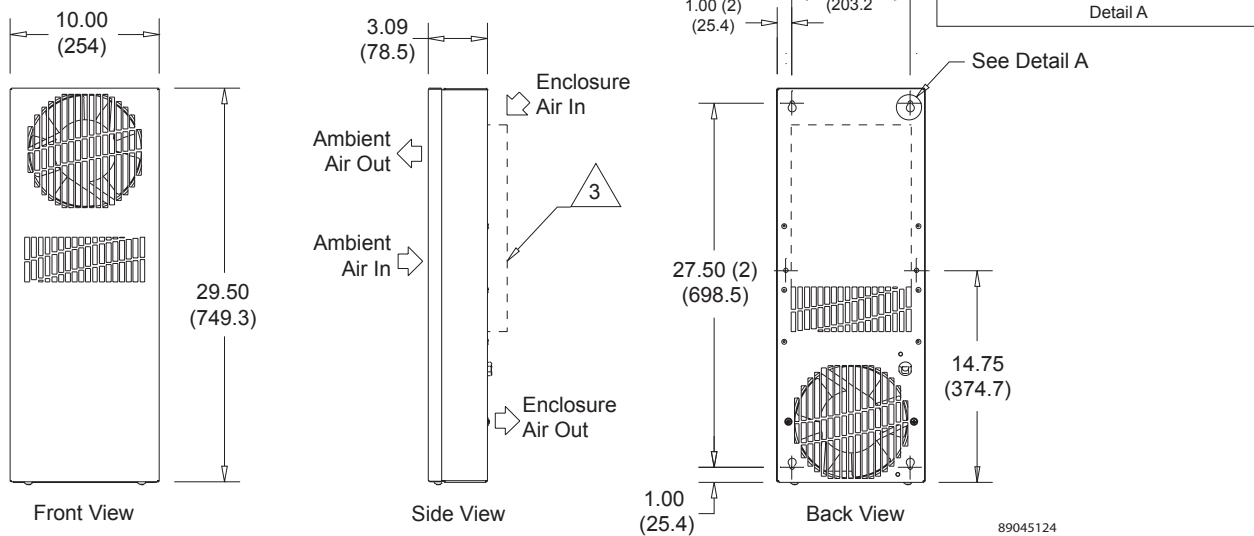

Note:

1. Supplied with mounting gasket kit.
2. Service cord terminated with appropriate plug:
 NEMA 5-15P for 115V units
 NEMA 6-15P for 230V units
3. Detachable airflow plenum may be used when mounting the heat exchanger inside or outside of the enclosure.

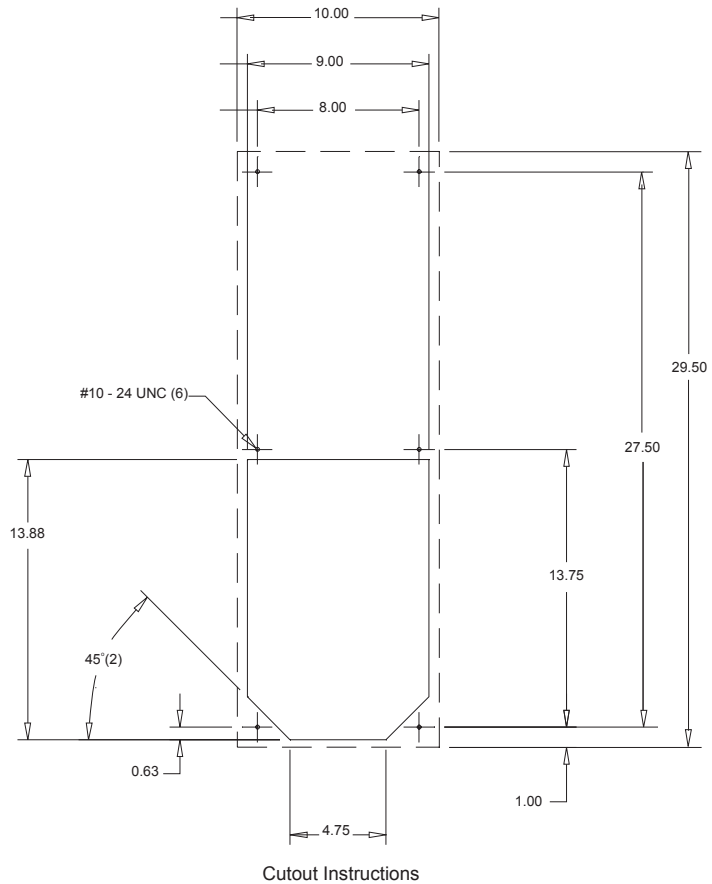

Visit www.McLeanCoolingTech.com to download 2D and 3D CAD drawings into the overall design of your electronic system.

Performance Data **XR29 Models 18 W/°F (32 W/°C)**

CATALOG NUMBER		
	XR291816012	XR291826012
COOLING PERFORMANCE		
Nominal:		
W per °F	18	18
W per °C	32	32
Refrigerant	N/A	N/A
Refrigerant Charge (ounces/grams)	N/A	N/A
Operating Temperature Range:		
Maximum (°F/°C)	140/60	140/60
Minimum (°F/°C)	-20/-29	-20/-29
Airflow at 0 Static Pressure:		
Internal loop 50 Hz (CFM/m ³ /hr.)	126/214	126/214
External loop 50 Hz (CFM/m ³ /hr.)	120/204	120/204
Internal loop 60 Hz (CFM/m ³ /hr.)	140/237	140/237
External loop 60 Hz (CFM/m ³ /hr.)	133/226	133/226
ELECTRICAL DATA		
Rated Voltage	115	230
Frequency (Hz)	50/60	50/60
Operating Range	+/- 10%	+/- 10%
Max. Power Consumption (W at 50/60 Hz)	207	207
Max. Nominal Current (A at 50/60 Hz)	1.8	0.9
Agency Approvals	cUL Listed CE	
Power Input Description	6-ft. cord with NEMA 5-15 plug	6-ft. cord with NEMA 6-15 plug
ENCLOSURE PROTECTION		
UL Type	Type 12 standard Type 3R/4/4X optional	
SOUND LEVEL		
At 1.5 Meters	64 dBA	
UNIT CONSTRUCTION		
Material	Mild steel sheet metal standard Stainless steel optional	
Finish	RAL 7035 light-gray, semi-textured powder-coat paint standard	
UNIT DIMENSIONS		
Height (in./mm)	29.66/753.3	29.66/753.3
Width (in./mm)	10.24/260.1	10.24/260.1
Depth (in./mm)	5.92/150.4	5.92/150.4
Weight (lb./kg)	32/15	32/15

PROAIR Indoor Heat Exchangers

PROAIR HEX

XR29 Models 18 W/°F (32 W/°C)

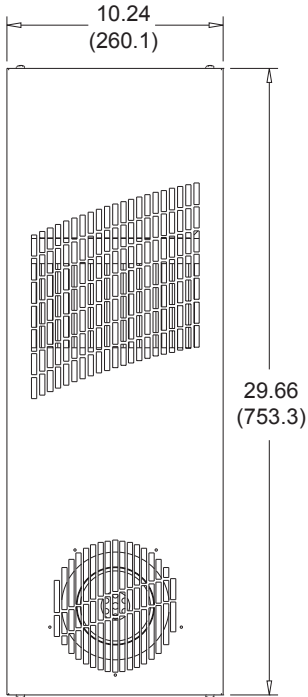

Front View

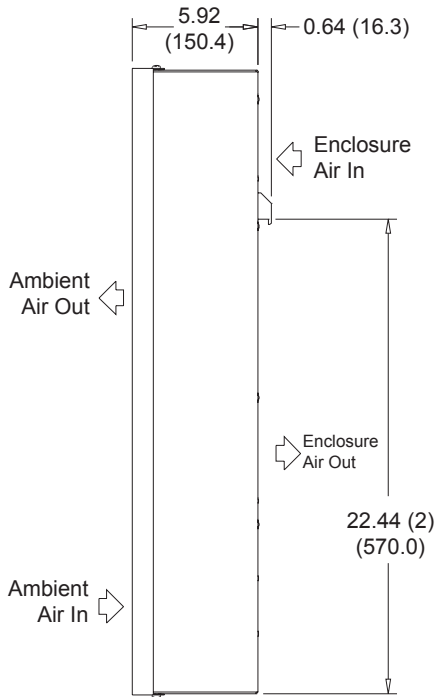

Side View

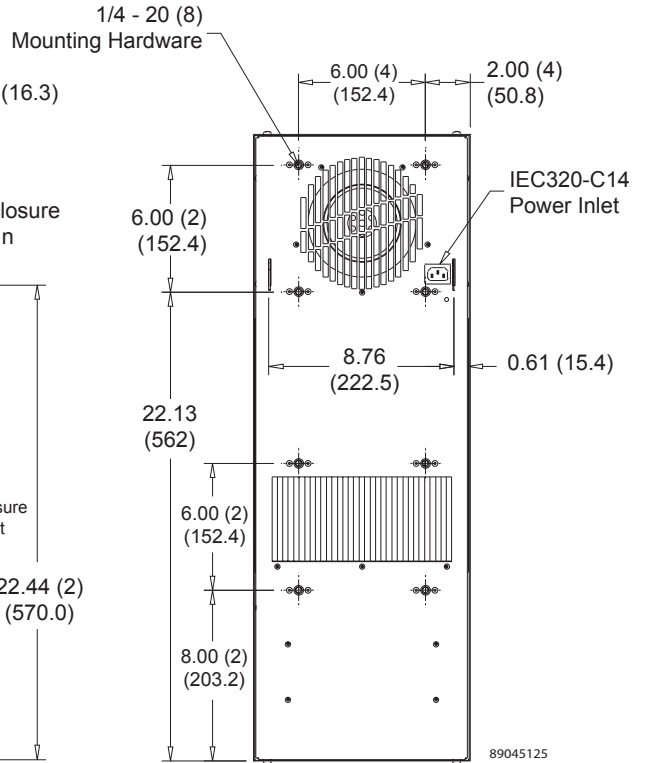

Back View

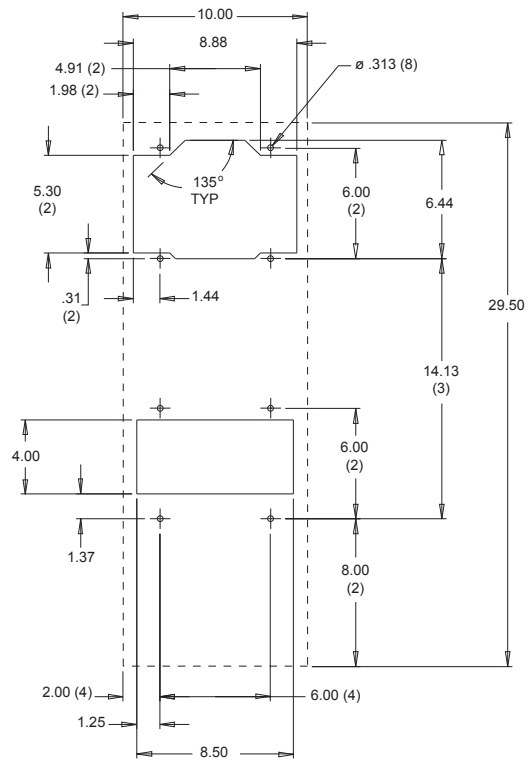

Cutout Instructions

Visit www.McLeanCoolingTech.com to download 2D and 3D CAD drawings into the overall design of your electronic system.

Performance Data **XR47 Models 24 W/°F (43 W/°C)**

CATALOG NUMBER		
	XR472416012	XR472426012
COOLING PERFORMANCE		
Nominal:		
W per °F	24	24
W per °C	43	43
Refrigerant	N/A	N/A
Refrigerant Charge (ounces/grams)	N/A	N/A
Operating Temperature Range:		
Maximum (°F/°C)	140/60	140/60
Minimum (°F/°C)	-20/-29	-20/-29
Airflow at 0 Static Pressure:		
Internal loop 50 Hz (CFM/m ³ /hr.)	140/238	140/238
External loop 50 Hz (CFM/m ³ /hr.)	118/200	118/200
Internal loop 60 Hz (CFM/m ³ /hr.)	156/265	156/265
External loop 60 Hz (CFM/m ³ /hr.)	131/222	131/222
ELECTRICAL DATA		
Rated Voltage	115	230
Frequency (Hz)	50/60	50/60
Operating Range	+/- 10%	+/- 10%
Max. Power Consumption (W at 50/60 Hz)	207	207
Max. Nominal Current (A at 50/60 Hz)	1.8	0.9
Agency Approvals	cUL Listed CE	
Power Input Description	6-ft. cord with NEMA 5-15 plug	6-ft. cord with NEMA 6-15 plug
ENCLOSURE PROTECTION		
UL Type	Type 12 standard Type 3R/4/4X optional	
SOUND LEVEL		
At 1.5 Meters	68 dBA	
UNIT CONSTRUCTION		
Material	Mild steel sheet metal standard Stainless steel optional	
Finish	RAL 7035 light-gray, semi-textured powder-coat paint standard	
UNIT DIMENSIONS		
Height (in./mm)	47.16/1197.9	47.16/1197.9
Width (in./mm)	10.24/260.1	10.24/260.1
Depth (in./mm)	5.92/150.4	5.92/150.4
Weight (lb./kg)	51/23	51/23

PROAIR HEX

PROAIR Indoor Heat Exchangers

XR47 Models 24 W/°F (43 W/°C)

PROAIR HEX

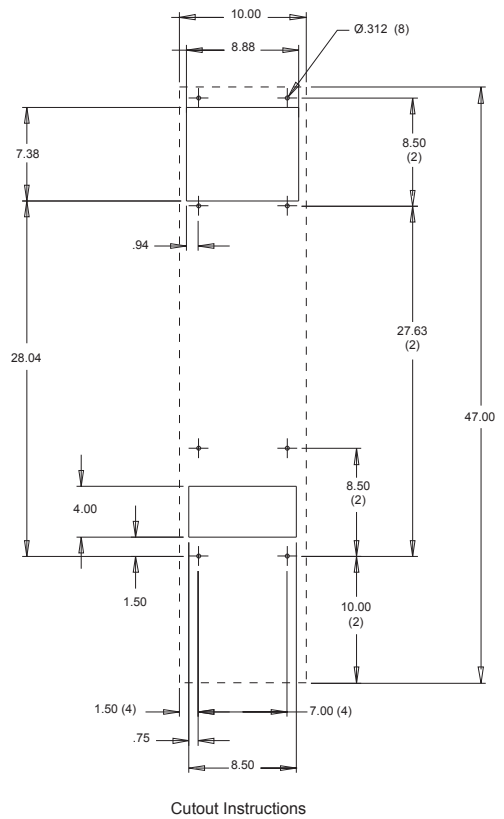
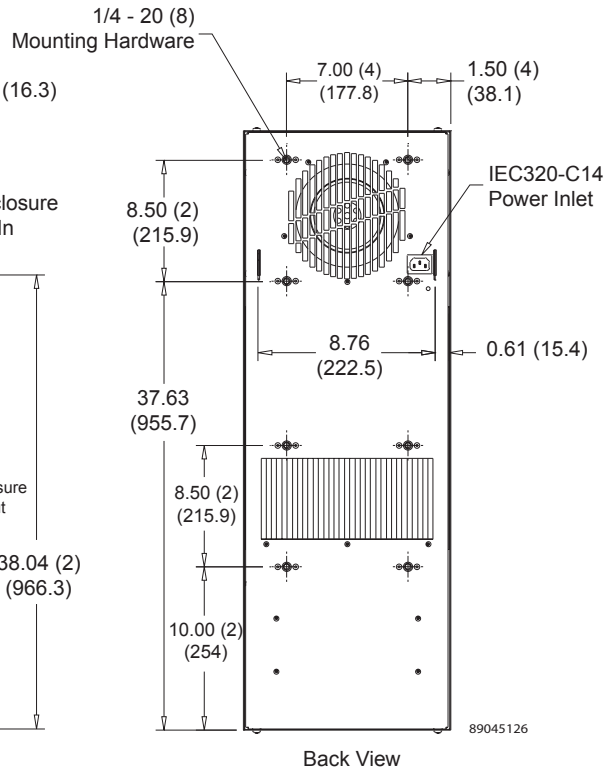
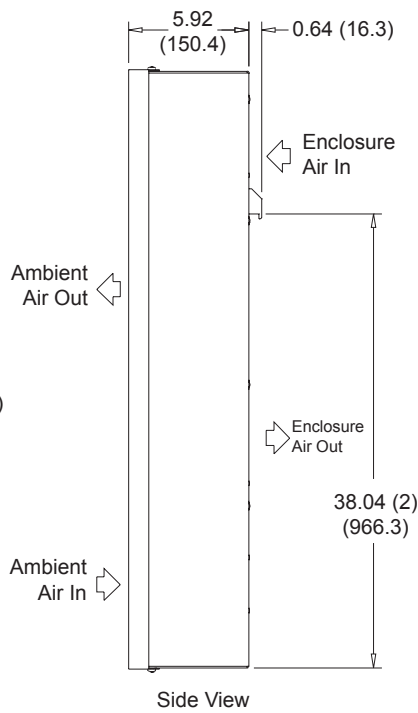
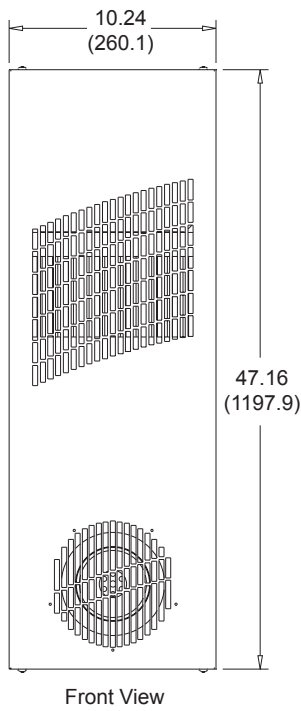

Visit www.McLeanCoolingTech.com to download 2D and 3D CAD drawings into the overall design of your electronic system.

Performance Data **XR47 Models 35 W/°F (63 W/°C)**

CATALOG NUMBER		
	XR473516012	XR473526012
COOLING PERFORMANCE		
Nominal:		
W per °F	35	35
W per °C	63	63
Refrigerant	N/A	N/A
Refrigerant Charge (ounces/grams)	N/A	N/A
Operating Temperature Range:		
Maximum (°F/°C)	140/60	140/60
Minimum (°F/°C)	-20/-29	-20/-29
Airflow at 0 Static Pressure:		
Internal loop 50 Hz (CFM/m ³ /hr.)	120/204	120/204
External loop 50 Hz (CFM/m ³ /hr.)	131/222	131/222
Internal loop 60 Hz (CFM/m ³ /hr.)	133/226	133/226
External loop 60 Hz (CFM/m ³ /hr.)	146/248	146/248
ELECTRICAL DATA		
Rated Voltage	115	230
Frequency (Hz)	50/60	50/60
Operating Range	+/- 10%	+/- 10%
Max. Power Consumption (W at 50/60 Hz)	207	207
Max. Nominal Current (A at 50/60 Hz)	1.8	0.9
Agency Approvals	cUL Listed CE	
Power Input Description	6-ft. cord with NEMA 5-15 plug	6-ft. cord with NEMA 6-15 plug
ENCLOSURE PROTECTION		
UL Type	Type 12 standard Type 3R/4/4X optional	
SOUND LEVEL		
At 1.5 Meters	68 dBA	
UNIT CONSTRUCTION		
Material	Mild steel sheet metal standard Stainless steel optional	
Finish	RAL 7035 light-gray, semi-textured powder-coat paint standard	
UNIT DIMENSIONS		
Height (in./mm)	47.16/1197.8	47.16/1197.8
Width (in./mm)	15.24/387.1	15.24/387.1
Depth (in./mm)	5.92/150.4	5.92/150.4
Weight (lb./kg)	59/27	59/27

PROAIR Indoor Heat Exchangers

PROAIR HEX

XR47 Models 35 W/°F (63 W/°C)

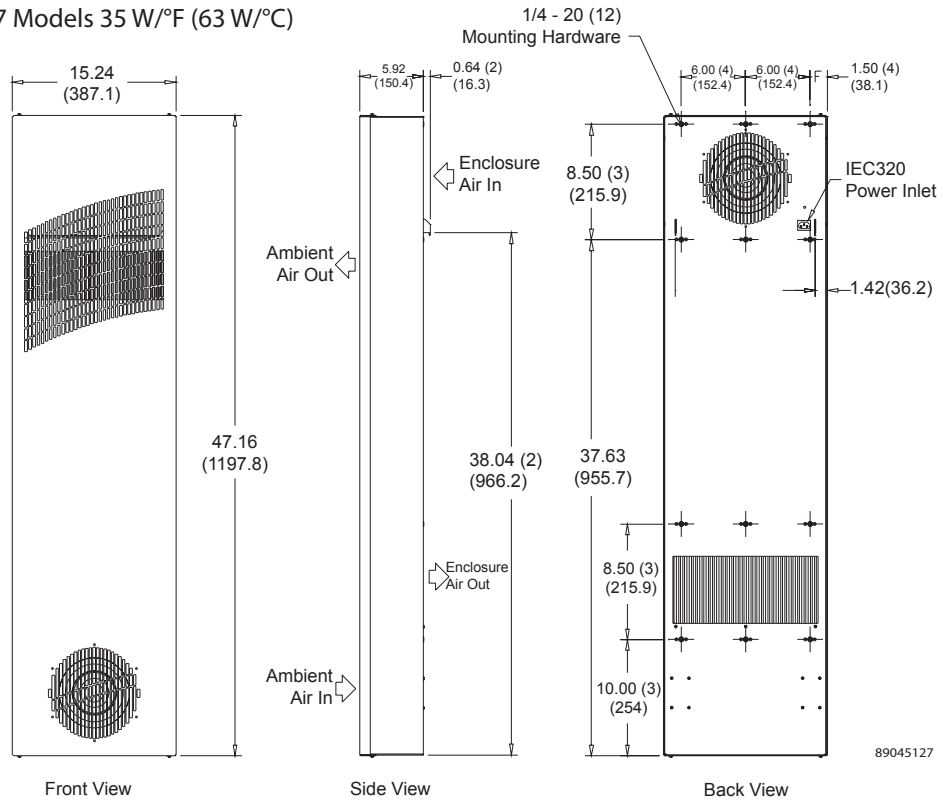

89045127

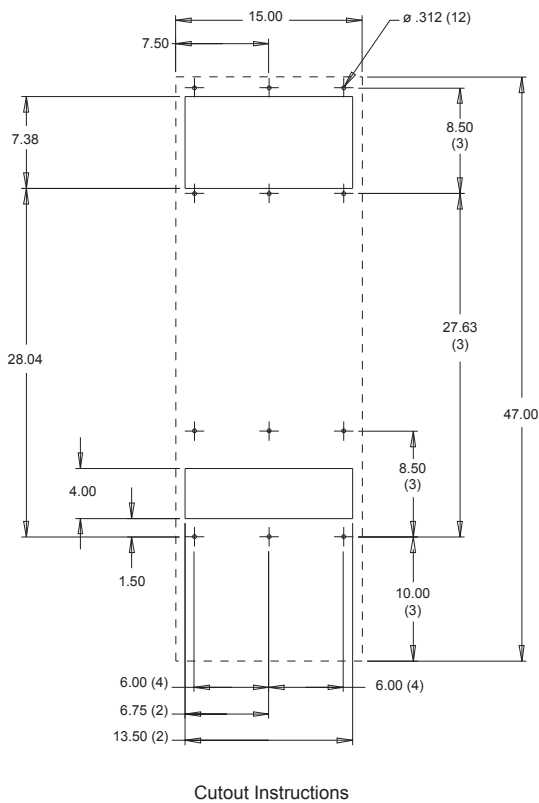

- Note:
1. Supplied with mounting gasket kit (not shown).
 2. 2-meter long service cord supplied with appropriate plug:
NEMA 5-15P for 115V units
NEMA 6-15P for 230V units

Visit www.McLeanCoolingTech.com to download 2D and 3D CAD drawings into the overall design of your electronic system.

Performance Data **XR60 Models 55 W/°F (99 W/°C)**

CATALOG NUMBER		
	XR605516012	XR605526012
COOLING PERFORMANCE		
Nominal:		
W per °F	55	55
W per °C	99	99
Refrigerant	N/A	N/A
Refrigerant Charge (ounces/grams)	N/A	N/A
Operating Temperature Range:		
Maximum (°F/°C)	140/60	140/60
Minimum (°F/°C)	-20/-29	-20/-29
Airflow at 0 Static Pressure:		
Internal loop 50 Hz (CFM/m ³ /hr.)	398/676	398/676
External loop 50 Hz (CFM/m ³ /hr.)	429/729	429/729
Internal loop 60 Hz (CFM/m ³ /hr.)	442/751	442/751
External loop 60 Hz (CFM/m ³ /hr.)	477/810	477/810
ELECTRICAL DATA		
Rated Voltage	115	230
Frequency (Hz)	50/60	50/60
Operating Range	+/- 10%	+/- 10%
Max. Power Consumption (W at 50/60 Hz)	759	759
Max. Nominal Current (A at 50/60 Hz)	6.6	3.3
Agency Approvals	cUL Listed CE	
Power Input Description	6-ft. cord with NEMA 5-15 plug	6-ft. cord with NEMA 6-15 plug
ENCLOSURE PROTECTION		
UL Type	Type 12 standard Type 3R/4/4X optional	
SOUND LEVEL		
At 1.5 Meters	73 dBA	
UNIT CONSTRUCTION		
Material	Mild steel sheet metal standard Stainless steel optional	
Finish	RAL 7035 light-gray, semi-textured powder-coat paint standard	
UNIT DIMENSIONS		
Height (in./mm)	59.66/1515.3	59.66/1515.3
Width (in./mm)	15.24/387.1	15.24/387.1
Depth (in./mm)	5.92/150.4	5.92/150.4
Weight (lb./kg)	86/39	86/39

PROAIR Indoor Heat Exchangers

PROAIR HEX

XR60 Models 55 W/°F (99 W/°C)

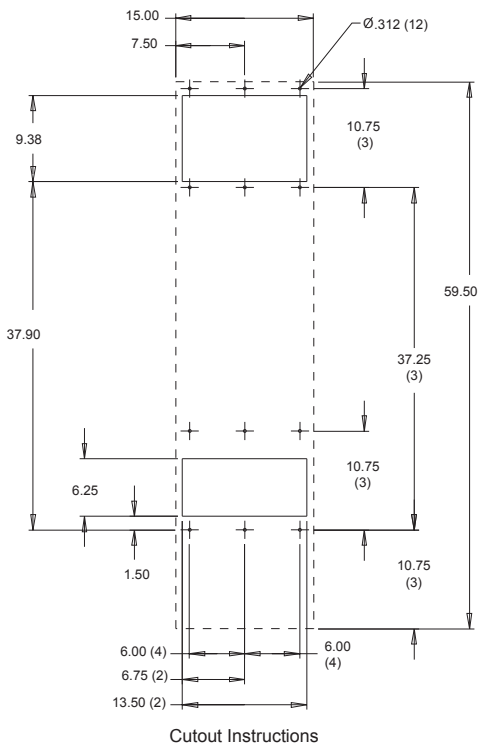
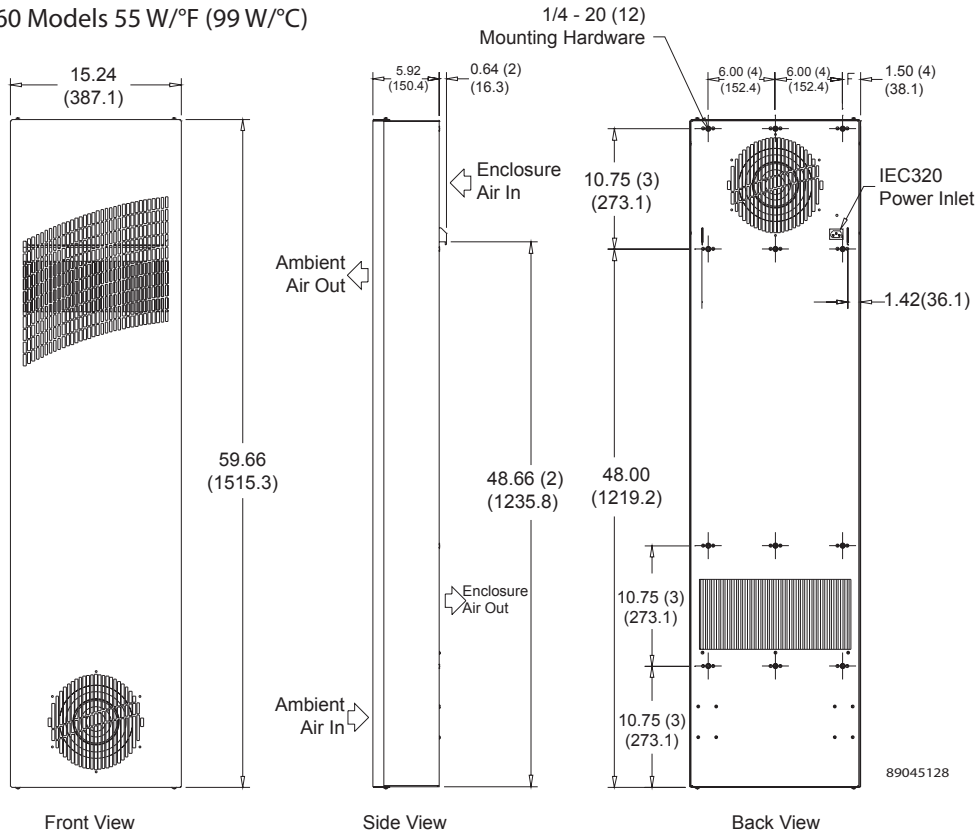

- Note:
1. Supplied with mounting gasket kit (not shown).
 2. 2-meter long service cord supplied with appropriate plug:
NEMA 5-15P for 115V units
NEMA 6-15P for 230V units

Visit www.McLeanCoolingTech.com to download 2D and 3D CAD drawings into the overall design of your electronic system.

Performance Data **XR60 Models 84 W/°F (151 W/°C)**

CATALOG NUMBER		
	XR608416012	XR608426012
COOLING PERFORMANCE		
Nominal:		
W per °F	84	84
W per °C	151	151
Refrigerant	N/A	N/A
Refrigerant Charge (ounces/grams)	N/A	N/A
Operating Temperature Range:		
Maximum (°F/°C)	140/60	140/60
Minimum (°F/°C)	-20/-29	-20/-29
Airflow at 0 Static Pressure:		
Internal loop 50 Hz (CFM/m ³ /hr.)	497/844	497/844
External loop 50 Hz (CFM/m ³ /hr.)	434/737	434/737
Internal loop 60 Hz (CFM/m ³ /hr.)	552/938	552/938
External loop 60 Hz (CFM/m ³ /hr.)	482/819	482/819
ELECTRICAL DATA		
Rated Voltage	115	230
Frequency (Hz)	50/60	50/60
Operating Range	+/- 10%	+/- 10%
Max. Power Consumption (W at 50/60 Hz)	759	759
Max. Nominal Current (A at 50/60 Hz)	6.6	3.3
Agency Approvals	cUL Listed CE	
Power Input Description	6-ft. cord with NEMA 5-15 plug	6-ft. cord with NEMA 6-15 plug
ENCLOSURE PROTECTION		
UL Type	Type 12 standard Type 3R/4/4X optional	
SOUND LEVEL		
At 1.5 Meters	73 dBA	
UNIT CONSTRUCTION		
Material	Mild steel sheet metal standard Stainless steel optional	
Finish	RAL 7035 light-gray, semi-textured powder-coat paint standard	
UNIT DIMENSIONS		
Height (in./mm)	59.66/1515.3	59.66/1515.3
Width (in./mm)	15.24/387.1	15.24/387.1
Depth (in./mm)	9.92/252	9.92/252
Weight (lb./kg)	106/48	106/48

PROAIR Indoor Heat Exchangers

PROAIR HEX

XR60 Models 84 W/°F (151 W/°C)

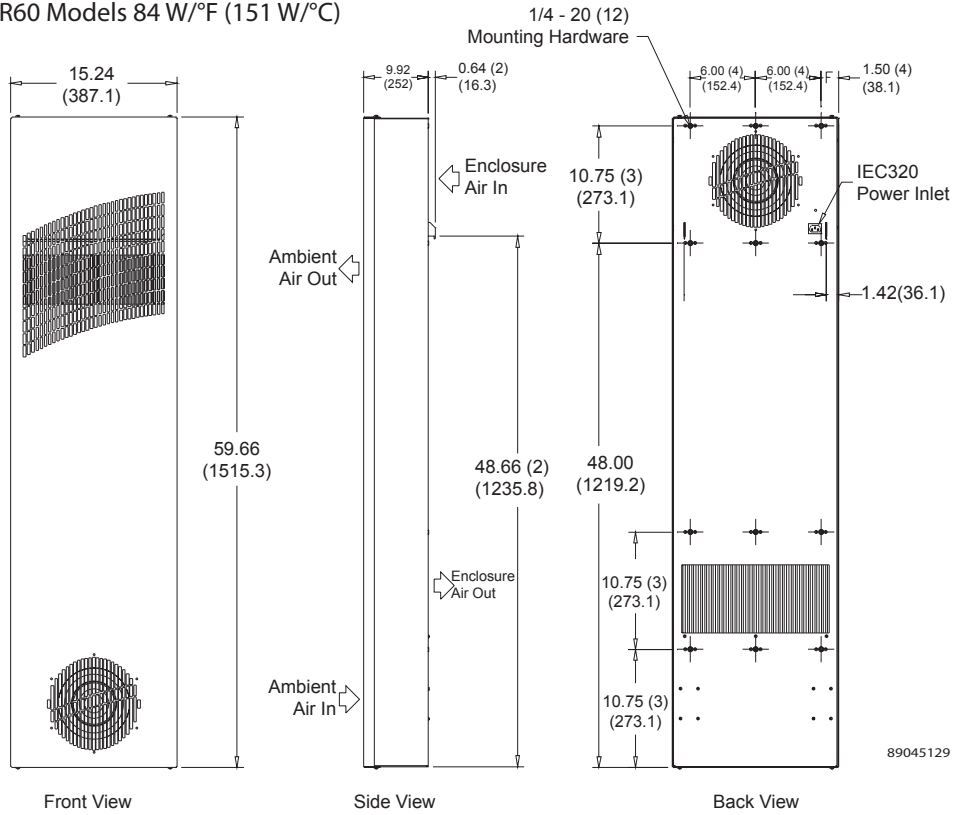

89045129

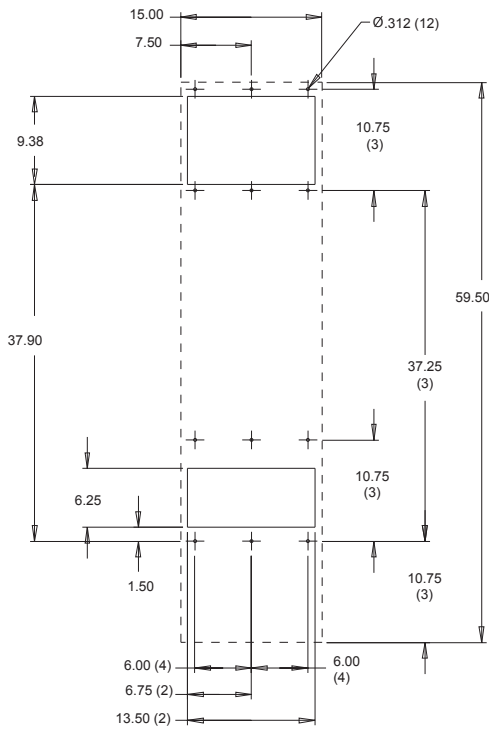

Cutout Instructions

- Note:
1. Supplied with mounting gasket kit (not shown).
 2. 2-meter long service cord supplied with appropriate plug:
NEMA 5-15P for 115V units
NEMA 6-15P for 230V units

Visit www.McLeanCoolingTech.com to download 2D and 3D CAD drawings into the overall design of your electronic system.

Notes

CLIMAGUARD™ Outdoor Heat Exchangers

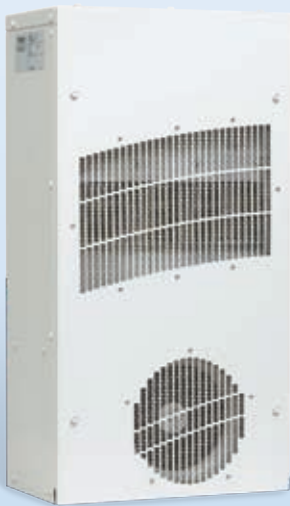

TX23 Model

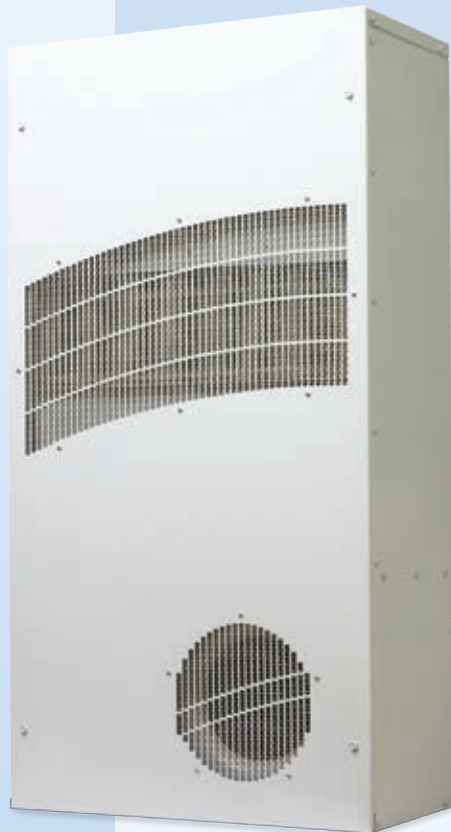

TX38 Model



TX52 Model

*Lab- and field-tested
to seal out extreme weather*



CLIMAGUARD™ Outdoor Heat Exchangers

PRODUCT OVERVIEW

Put this Type 4 / Telcordia GR-487-capable heat exchanger to the test. You'll find that every unit keeps your outdoor enclosure sealed tight for reliable closed-loop cooling. Works on AC or DC voltage power input.

APPLICATIONS

- Telecommunications cabinets
- Alternative energy
- Outside plant applications
- Other outdoor electronic systems

CLIMAGUARD Outdoor Heat Exchangers Chapter Contents

Outdoor Heat Exchangers	144
TX23 Outdoor Model	145
TX33 Outdoor Model	148
TX38 Outdoor Model	151
TX52 Outdoor Model	154

Outdoor Heat Exchangers

CLIMAGUARD HEX



TX23
Models
14 W/°F (25 W/°C)



TX33
Models
28 W/°F (50 W/°C)



TX38
Models
56 W/°F (100 W/°C)



TX52
Models
83 W/°F (150 W/°C)

Industry Standards

UL/cUL Listed or UR/cUR Recognized

- CE
- Telcordia GR-487 capable
- Type 12/3R/4 Standard
- Type 4X stainless steel option available

Application

- Telecom shelters
- Outdoor cabinets
- Equipment buildings
- Instrument enclosures
- And more

Features

- Unique counterflow aluminum core for high efficiency and high performance heat transfer
- Models for 24 VDC, 48 VDC, 115 VAC and 230 VAC power supplies
- UL Listed or Recognized to save customers time and money with agency approvals
- Operating temperature range from -40 F/-40 C to 149 F/65 C
- Variable speed blowers standard on DC powered units for quiet running
- Surface or recessed mount capable
- Low-carbon mild-steel sheet-metal cover for rugged factory environments
- Easy-mount flanges for simple installation

- Mounting hardware, gaskets and user manual furnished with the unit
- Every unit functionally tested before shipping
- Filterless design for low maintenance and easy cleaning
- Engineered for temperature extremes, corrosive environments and wind driven rain

Finish

- RAL 7035 light-gray, semi-textured powder-coat paint standard
- Stainless steel Type 304 or 316 finishes available on Type 4X models
- Other colors and textures available

Options

- Thermostat Package
 - Special Voltage Package
 - Outdoor Package
 - Harsh Environment Package*
 - Stainless Steel Package*
 - Heater Package*
- * Consult the factory for availability and catalog number.

Notes

Visit www.McLeanCoolingTech.com to download 2D and 3D CAD drawings into the overall design of your electronic system

Performance Data **TX23 Models 14 W/°F (25 W/°C)**

CATALOG NUMBER	TX231416100	TX231426100	TX231424100	TX231448100
COOLING PERFORMANCE				
Nominal:				
W per °F	14	14	14	14
W per °C	25	25	25	25
Refrigerant	N/A	N/A	N/A	N/A
Refrigerant Charge (ounces/grams)	N/A	N/A	N/A	N/A
Operating Temperature Range				
Maximum (°F/°C)	149/65	149/65	149/65	149/65
Minimum (°F/°C)	-40/-40	-40/-40	-40/-40	-40/-40
Airflow at 0 Static Pressure:				
Internal loop 50 Hz (CFM / m ³ /hr.)	69/117	69/117	N/A	N/A
External loop 50 Hz (CFM / m ³ /hr.)	58/98	58/98	N/A	N/A
Internal loop 60 Hz (CFM / m ³ /hr.)	84/142	84/142	175/268	175/268
External loop 60 Hz (CFM / m ³ /hr.)	69/117	69/117	158/297	158/297
ELECTRICAL DATA				
Rated Voltage	115 VAC	230 VAC	24 VDC	48 VDC
Frequency (Hz)	50/60	50/60	50/60	50/60
Operating Range	+/- 10%	+/- 10%	+/- 10%	+/- 10%
Max. Power Consumption (W at 50/60 Hz)	69	23	82	87
Max. Nominal Current (A at 50/60 Hz)	0.6	0.1	3.4	1.8
Agency Approvals	cUL Listed CE		cUL Listed CE	
Power Input Description	6-ft. cord with NEMA 5-15 plug	6-ft. cord with NEMA 6-15 plug	Terminal block	Terminal block
ENCLOSURE PROTECTION				
UL Type	Type 12/3R/4 standard 4X optional		Type 12/3R/4 standard 4X optional	
SOUND LEVEL				
At 1.5 M	56 dBA		56 dBA	
UNIT CONSTRUCTION				
Material	Mild steel sheet metal standard Stainless steel optional		Mild steel sheet metal standard Stainless steel optional	
Finish	RAL 7035 light-gray, semi-textured powder-coat paint standard		RAL 7035 light-gray, semi-textured powder-coat paint standard	
UNIT DIMENSIONS				
Height (in./mm)	23/584.2	23/584.2	23/584.2	23/584.2
Width (in./mm)	12/304.8	12/304.8	12/304.8	12/304.8
Depth (in./mm)	7.1/180.3	7.1/180.3	7.1/180.3	7.1/180.3
Weight (lb./kg)	30/13.6	30/13.6	30/13.6	30/13.6

TX23 DC Models 14 W/°F (25 W/°C)

CLIMAGUARD HEX

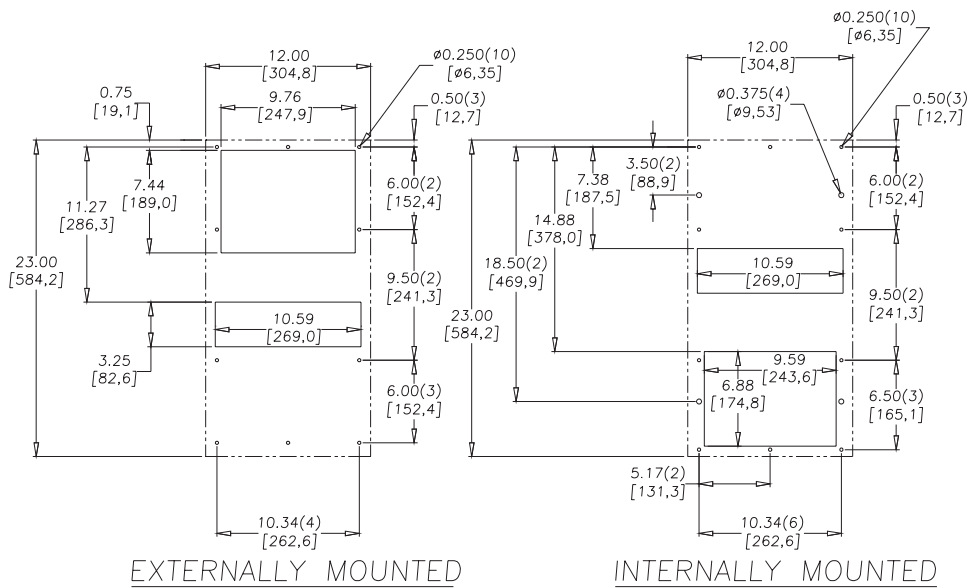
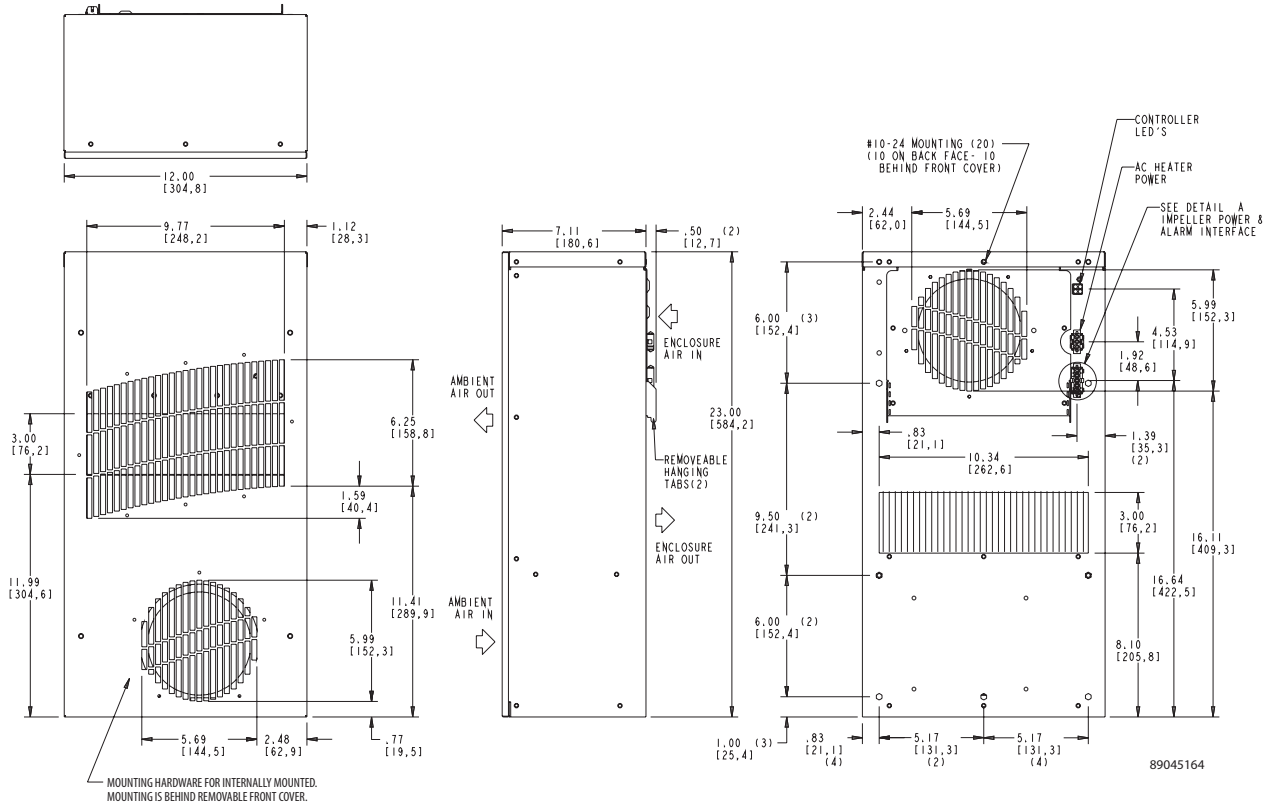

NOTES:
 1. DASHED LINES REPRESENT HEAT EXCHANGER.

Visit www.McLeanCoolingTech.com to download 2D and 3D CAD drawings into the overall design of your electronic system.

TX23 AC Models 14 W/°F (25 W/°C)

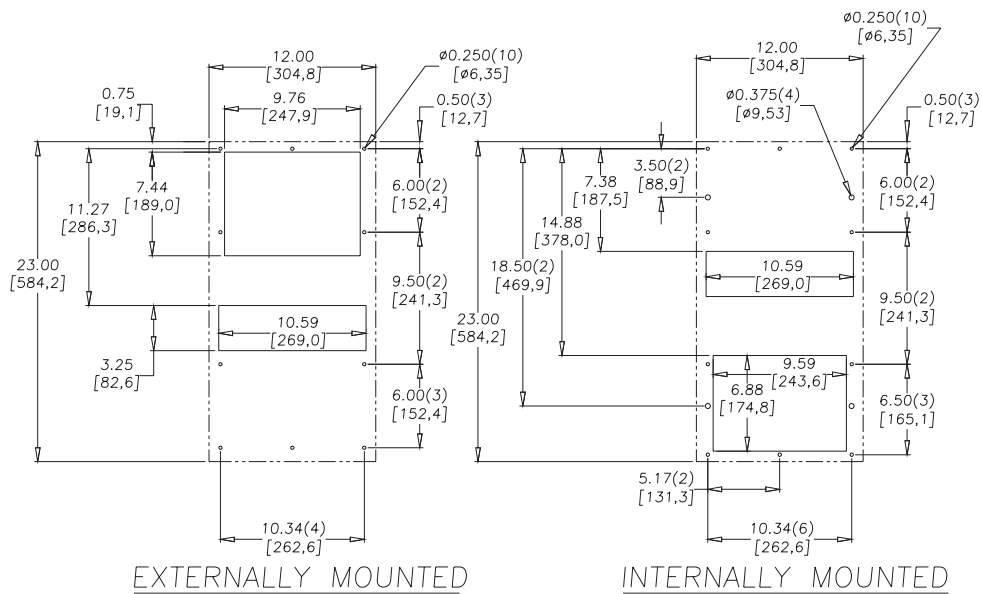
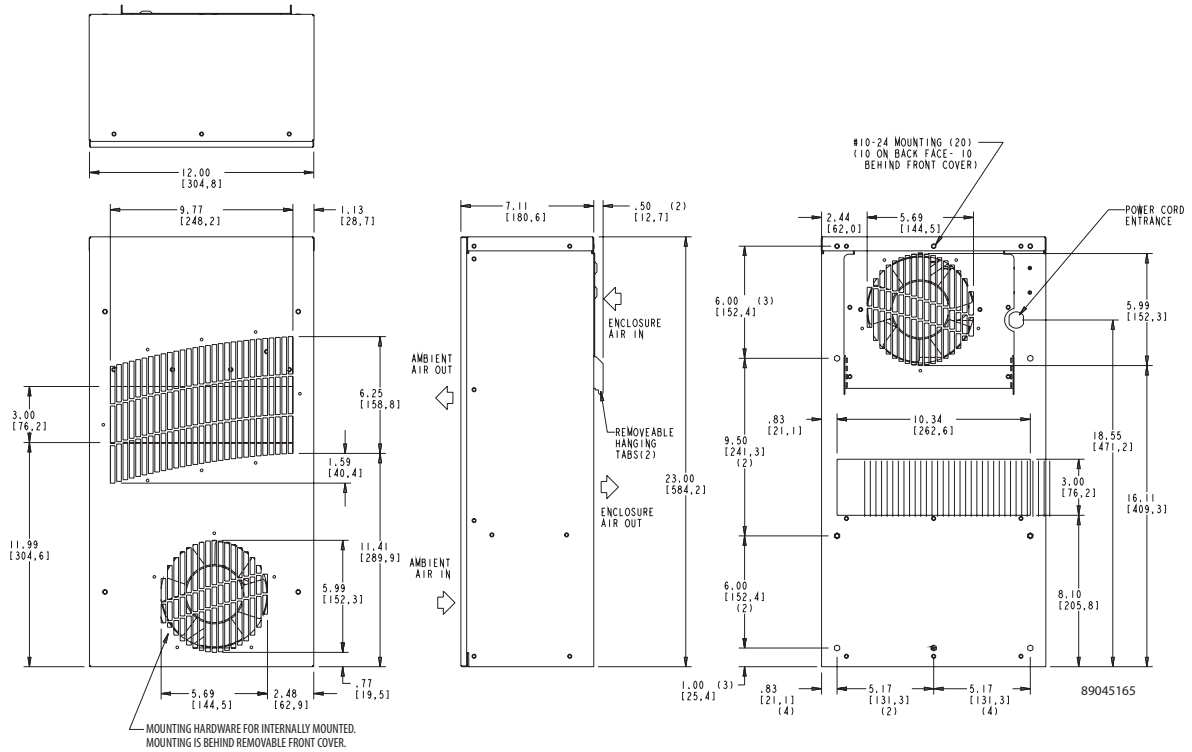

CUTOUT INSTRUCTIONS
 (AS VIEWED FROM OUTSIDE OF ENCLOSURE)

NOTES:
 1. DASHED LINES REPRESENT HEAT EXCHANGER.

Visit www.McLeanCoolingTech.com to download 2D and 3D CAD drawings into the overall design of your electronic system.

CLIMAGUARD HEX

Performance Data **TX33 Models 28 W/°F (50 W/°C)**

CATALOG NUMBER	TX332816100	TX332826100	TX332824100	TX332848100
COOLING PERFORMANCE				
Nominal:				
W per °F	28	28	28	28
W per °C	50	50	50	50
Refrigerant	N/A	N/A	N/A	N/A
Refrigerant Charge (ounces/grams)	N/A	N/A	N/A	N/A
Operating Temperature Range:				
Maximum (°F/°C)	149/65	149/65	149/65	149/65
Minimum (°F/°C)	-40/-40	-40/-40	-40/-40	-40/-40
Airflow at 0 Static Pressure:				
Internal loop 50 Hz (CFM / m ³ /hr.)	212/360	212/360	N/A	N/A
External loop 50 Hz (CFM / m ³ /hr.)	238/404	238/404	N/A	N/A
Internal loop 60 Hz (CFM / m ³ /hr.)	228/387	228/387	228/387	228/387
External loop 60 Hz (CFM / m ³ /hr.)	263/447	263/447	166/282	166/282
ELECTRICAL DATA				
Rated Voltage	115 VAC	230 VAC	24 VDC	48 VDC
Frequency (Hz)	50/60	50/60	50/60	50/60
Operating Range	+/- 10%	+/- 10%	+/- 10%	+/- 10%
Max. Power Consumption (W at 50/60 Hz)	161	92	82	87
Max. Nominal Current (A at 50/60 Hz)	1.4	0.4	3.4	1.8
Agency Approvals	cUL Listed CE		cUL Listed CE	
Power Input Description	6-ft. cord with NEMA 5-15 plug	6-ft. cord with NEMA 6-15 plug	Terminal block	Terminal block
ENCLOSURE PROTECTION				
UL Type	Type 12/3R/4 standard 4X optional		Type 12/3R/4 standard 4X optional	
SOUND LEVEL				
At 1.5 M	56 dBA		56 dBA	
UNIT CONSTRUCTION				
Material	Mild steel sheet metal standard Stainless steel optional		Mild steel sheet metal standard Stainless steel optional	
Finish	RAL 7035 light-gray, semi-textured powder-coat paint standard		RAL 7035 light-gray, semi-textured powder-coat paint standard	
UNIT DIMENSIONS				
Height (in./mm)	33/838.2	33/838.2	33/838.2	33/838.2
Width (in./mm)	15.7/398.8	15.7/398.8	15.7/398.8	15.7/398.8
Depth (in./mm)	8.1/205.7	8.1/205.7	8.1/205.7	8.1/205.7
Weight (lb./kg)	45/20.4	45/20.4	45/20.4	45/20.4

CLIMAGUARD HEX

TX33 DC Models 28 W/°F (50 W/°C)

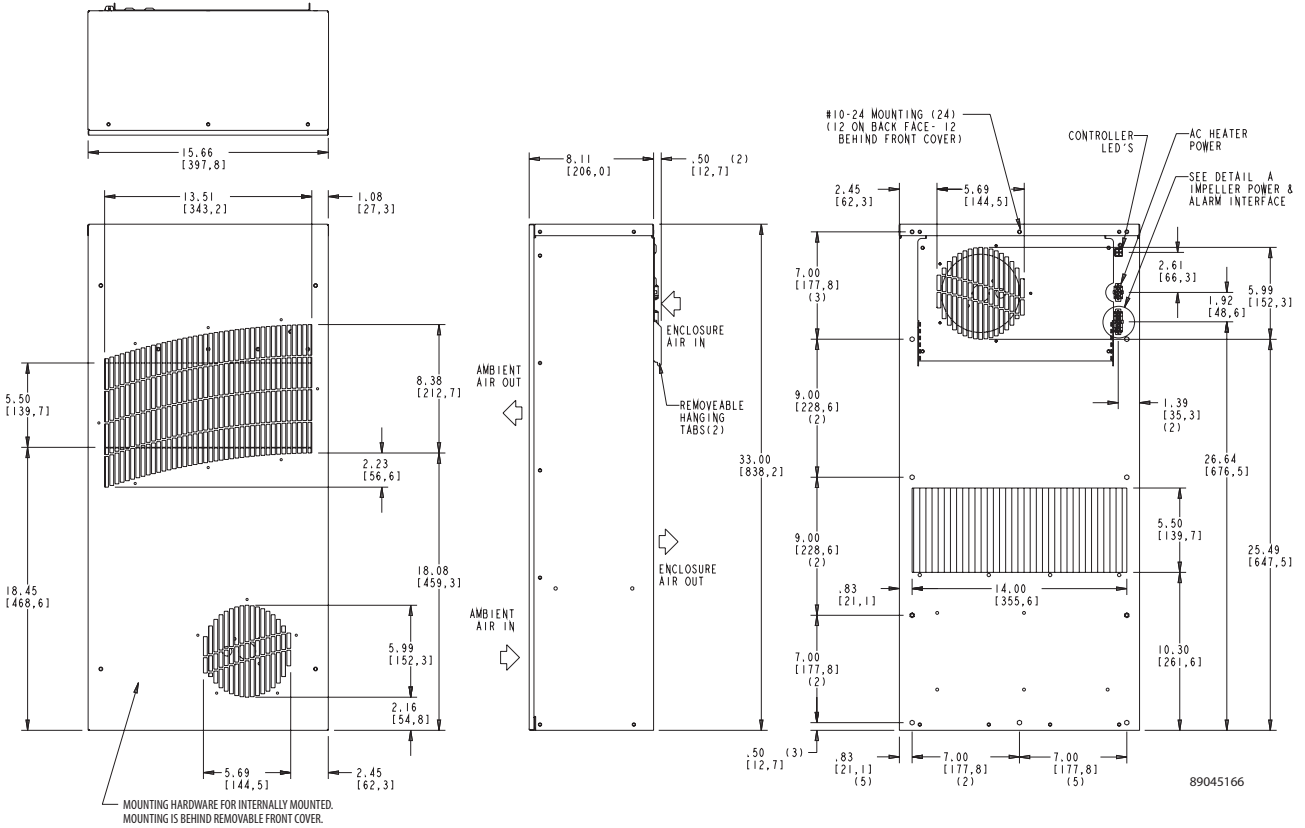

CLIMAGUARD HEX

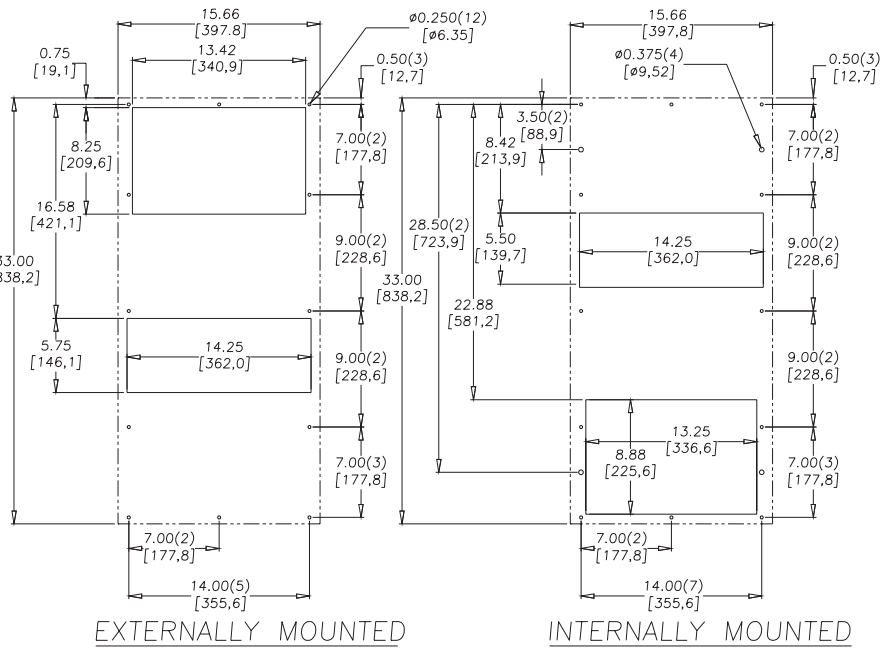

NOTES:
 1. DASHED LINES REPRESENT HEAT EXCHANGER.

Visit www.McLeanCoolingTech.com to download 2D and 3D CAD drawings into the overall design of your electronic system.

TX33 AC Models 28 W/°F (50 W/°C)

CLIMAGUARD HEX

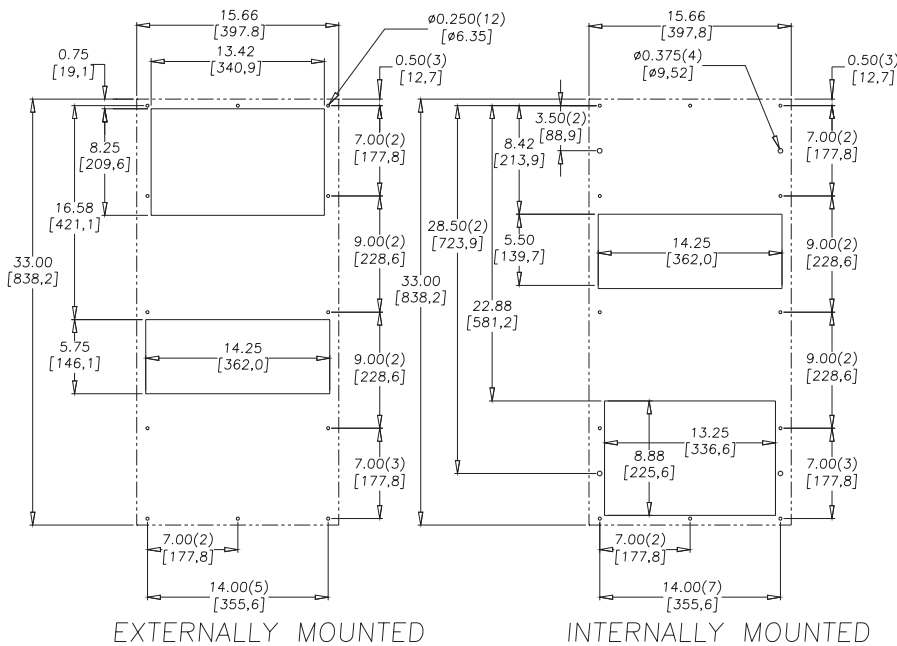
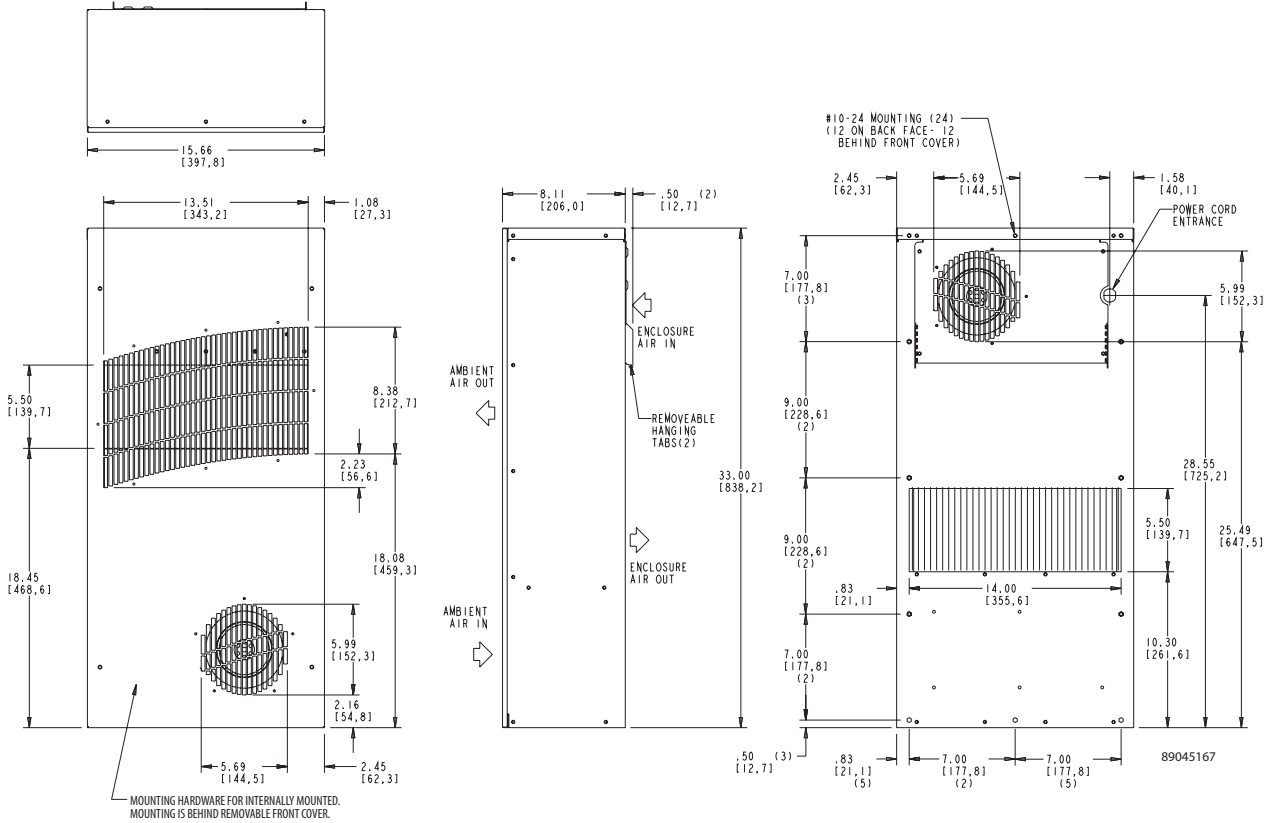

CUTOUT INSTRUCTIONS
 (AS VIEWED FROM OUTSIDE OF ENCLOSURE)

NOTES:
 1. DASHED LINES REPRESENT HEAT EXCHANGER.

Visit www.McLeanCoolingTech.com to download 2D and 3D CAD drawings into the overall design of your electronic system.

Performance Data **TX38 Models 56 W/°F (100 W/°C)**

CATALOG NUMBER	TX385616100	TX385626100	TX385624-00	TX385648100
COOLING PERFORMANCE				
Nominal:				
W per °F	56	56	56	56
W per °C	100	100	100	100
Refrigerant	N/A	N/A	N/A	N/A
Refrigerant Charge (ounces/grams)	N/A	N/A	N/A	N/A
Operating Temperature Range:				
Maximum (°F/°C)	149/65	149/65	149/65	149/65
Minimum (°F/°C)	-40/-40	-40/-40	-40/-40	-40/-40
Airflow at 0 Static Pressure:				
Internal loop 50 Hz (CFM / m ³ /hr.)	425/722	425/722	N/A	N/A
External loop 50 Hz (CFM / m ³ /hr.)	461/738	461/738	N/A	N/A
Internal loop 60 Hz (CFM / m ³ /hr.)	477/810	477/810	368/625	368/625
External loop 60 Hz (CFM / m ³ /hr.)	517/878	517/878	422/717	422/717
ELECTRICAL DATA				
Rated Voltage	115 VAC	230 VAC	24 VDC	48 VDC
Frequency (Hz)	50/60	50/60	50/60	50/60
Operating Range	+/- 10%	+/- 10%	+/- 10%	+/- 10%
Max. Power Consumption (W at 50/60 Hz)	368	276	207	279
Max. Nominal Current (A at 50/60 Hz)	2.3/3.2	0.7/1.2	8.6	5.8
Agency Approvals	cUL Listed CE		cUL Listed CE	
Power Input Description	6-ft. cord with NEMA 5-15 plug	6-ft. cord with NEMA 6-15 plug	Terminal block	Terminal block
ENCLOSURE PROTECTION				
UL Type	Type 12/3R/4 standard 4X optional		Type 12/3R/4 standard 4X optional	
SOUND LEVEL				
At 1.5 M	64 dBA		64 dBA	
UNIT CONSTRUCTION				
Material	Mild Mild steel sheet metal standard		Mild Mild steel sheet metal standard	
Finish	RAL 7035 light-gray, semi-textured powder-coat paint standard		RAL 7035 light-gray, semi-textured powder-coat paint standard	
UNIT DIMENSIONS				
Height (in./mm)	38/965.2	38/965.2	38/965.2	38/965.2
Width (in./mm)	19.7/500.4	19.7/500.4	19.7/500.4	19.7/500.4
Depth (in./mm)	10.1/256.5	10.1/256.5	10.1/256.5	10.1/256.5
Weight (lb./kg)	66/30	66/30	66/30	66/30

TX38 DC Models 56 W/°F (100 W/°C)

CLIMAGUARD HEX

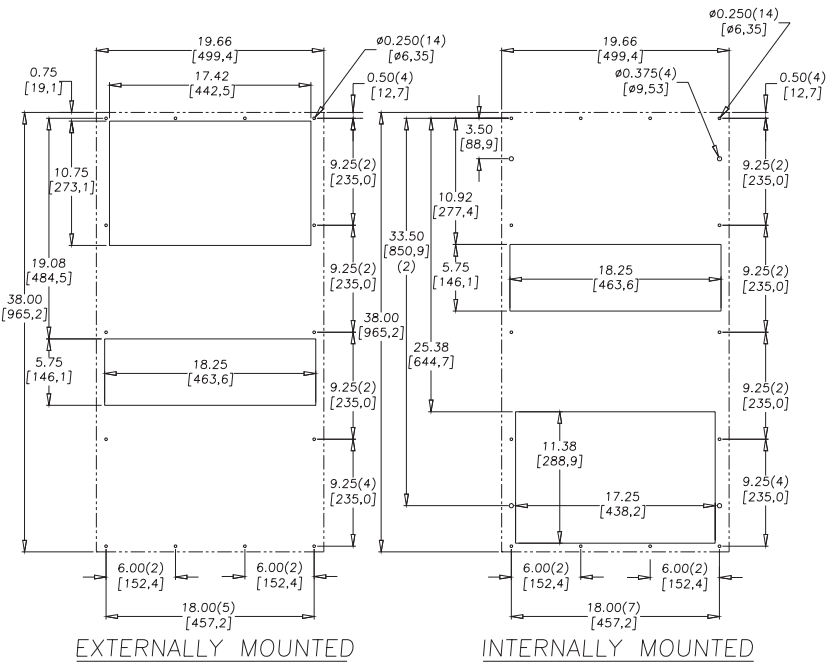
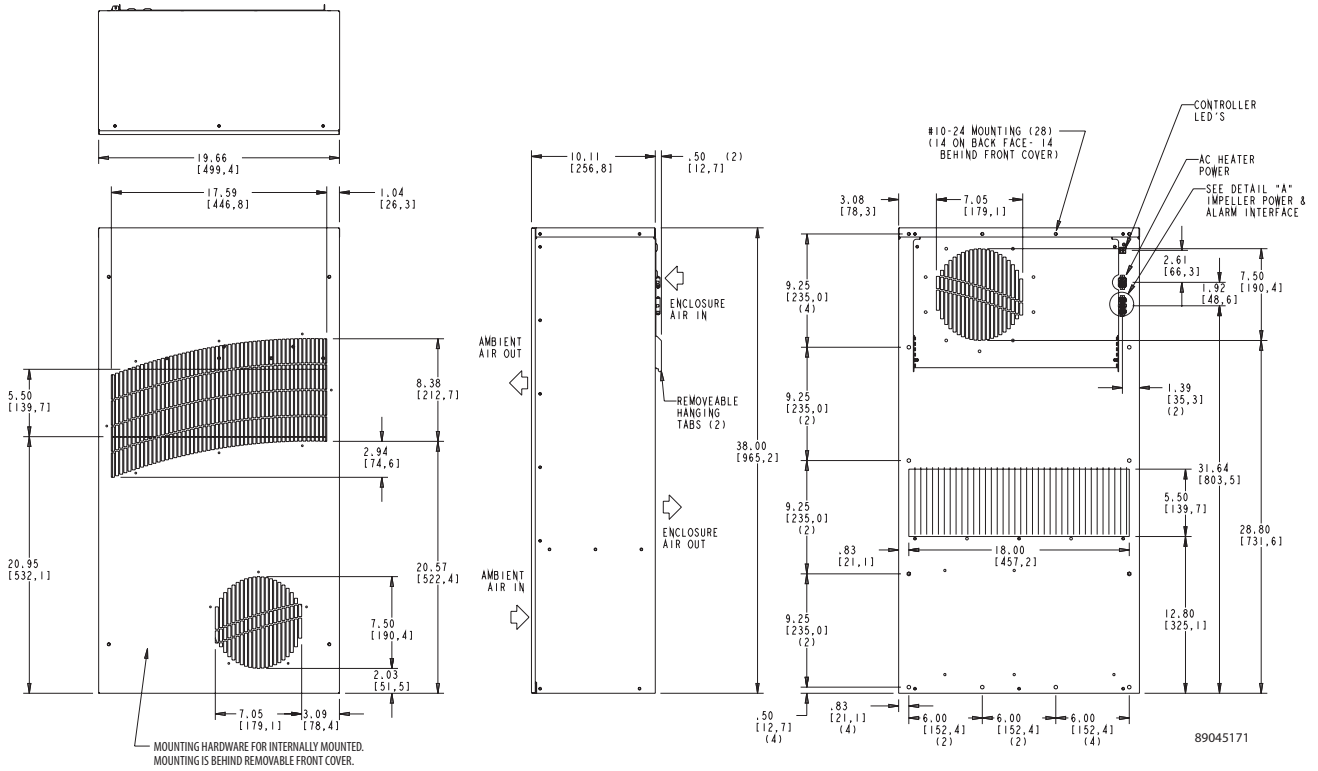

NOTES:
1. DASHED LINES REPRESENT HEAT EXCHANGER.

Visit www.McLeanCoolingTech.com to download 2D and 3D CAD drawings into the overall design of your electronic system.

TX38 AC Models 56 W/°F (100 W/°C)

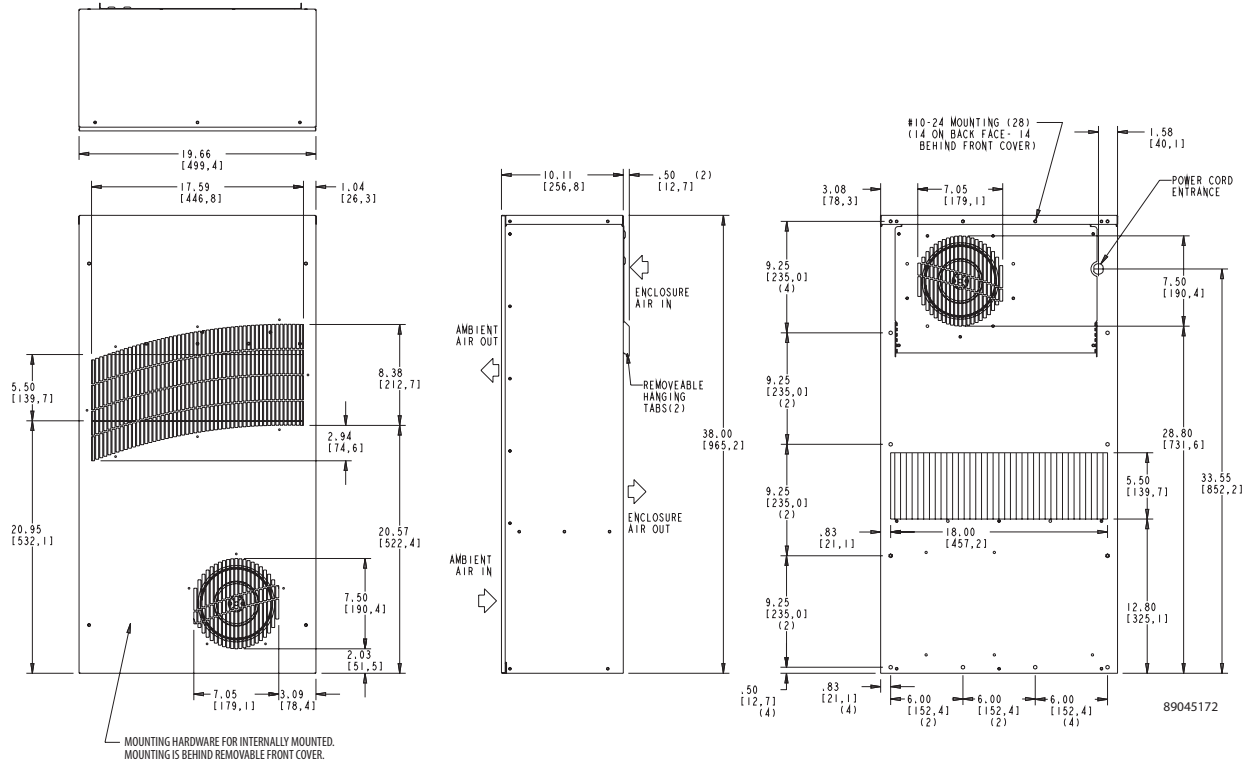

CLIMAGUARD HEX

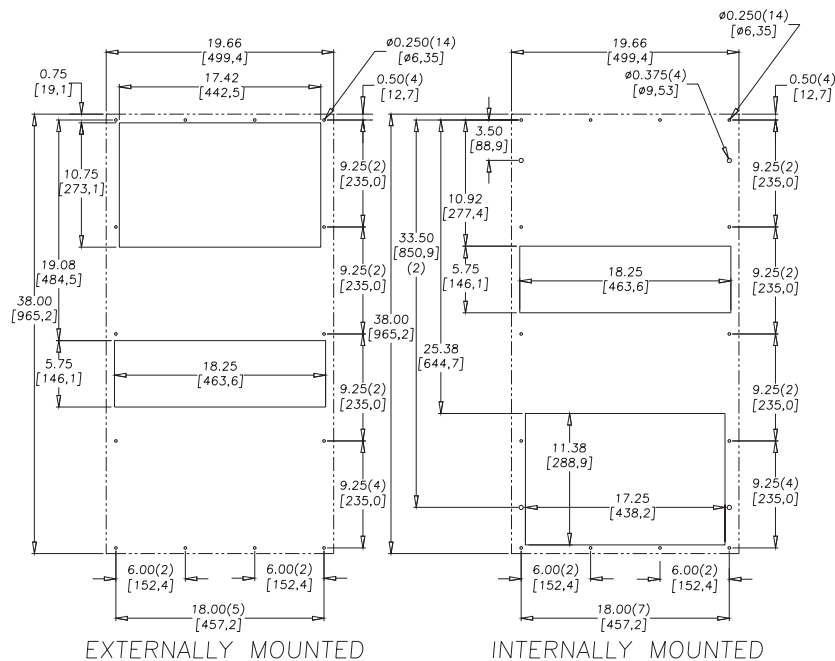

NOTES:
 1. DASHED LINES REPRESENT HEAT EXCHANGER.

Visit www.McLeanCoolingTech.com to download 2D and 3D CAD drawings into the overall design of your electronic system.

Performance Data **TX52 Models 83 W/°F (150 W/°C)**

CATALOG NUMBER	TX528316100	TX528326100	TX528324100	TX528348100
COOLING PERFORMANCE				
Nominal:				
W per °F	83	83	83	83
W per °C	150	150	150	150
Refrigerant	N/A	N/A	N/A	N/A
Refrigerant Charge (ounces/grams)	N/A	N/A	N/A	N/A
Operating Temperature Range:				
Maximum (°F/°C)	149/65	149/65	149/65	149/65
Minimum (°F/°C)	-40/-40	-40/-40	-40/-40	-40/-40
Airflow at 0 Static Pressure:				
Internal loop 50 Hz (CFM / m ³ /hr.)	495/841	495/841	N/A	N/A
External loop 50 Hz (CFM / m ³ /hr.)	540/917	540/917	N/A	N/A
Internal loop 60 Hz (CFM / m ³ /hr.)	533/905	533/905	466/792	466/792
External loop 60 Hz (CFM / m ³ /hr.)	605/1028	605/1028	547/929	547/929
ELECTRICAL DATA				
Rated Voltage	115 VAC	230 VAC	24 VDC	48 VDC
Frequency (Hz)	50/60	50/60	50/60	50/60
Operating Range	+/- 10%	+/- 10%	+/- 10%	+/- 10%
Max. Power Consumption (W at 50/60 Hz)	782	771	507	375
Max. Nominal Current (A at 50/60 Hz)	4.3/6.7	2.2/3.4	21.1	7.8
Agency Approvals	cUL Listed CE		cUL Listed CE	
Power Input Description	6-ft. cord with NEMA 5-15 plug	6-ft. cord with NEMA 6-15 plug	Terminal block	Terminal block
ENCLOSURE PROTECTION				
UL Type	Type 12/3R/4 standard 4X optional		Type 12/3R/4 standard 4X optional	
SOUND LEVEL				
At 1.5 M	68 dBA		68 dBA	
UNIT CONSTRUCTION				
Material	Mild steel sheet metal standard Stainless steel optional		Mild steel sheet metal standard Stainless steel optional	
Finish	RAL 7035 light-gray, semi-textured powder-coat paint standard		RAL 7035 light-gray, semi-textured powder-coat paint standard	
UNIT DIMENSIONS				
Height (in./mm)	52/1320.8	52/1320.8	52/1320.8	52/1320.8
Width (in./mm)	19.7/500.4	19.7/500.4	19.7/500.4	19.7/500.4
Depth (in./mm)	10.1/256.5	10.1/256.5	10.1/256.5	10.1/256.5
Weight (lb./kg)	100/45.3	100/45.3	100/45.3	100/45.3

CLIMAGUARD HEX

TX52 DC Models 83 W/°F (150 W/°C)

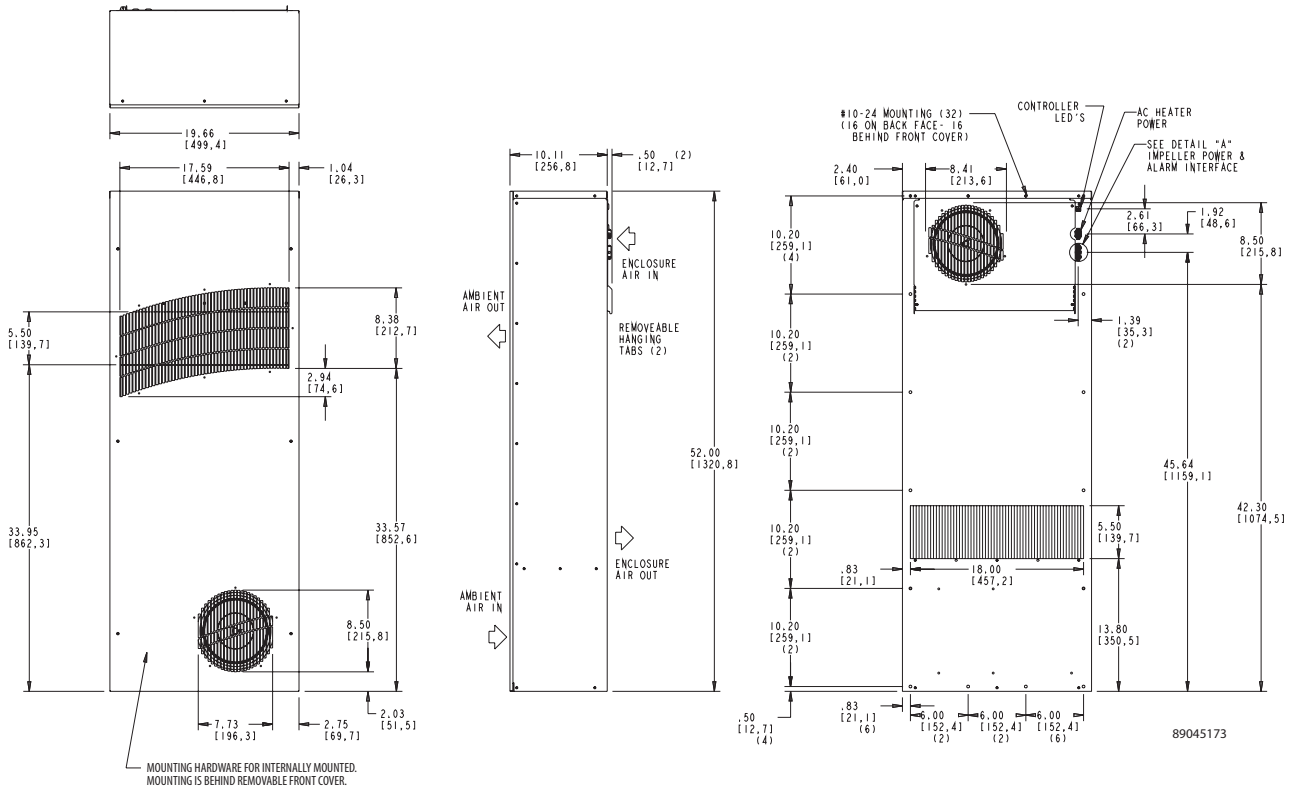

CLIMAGUARD HEX

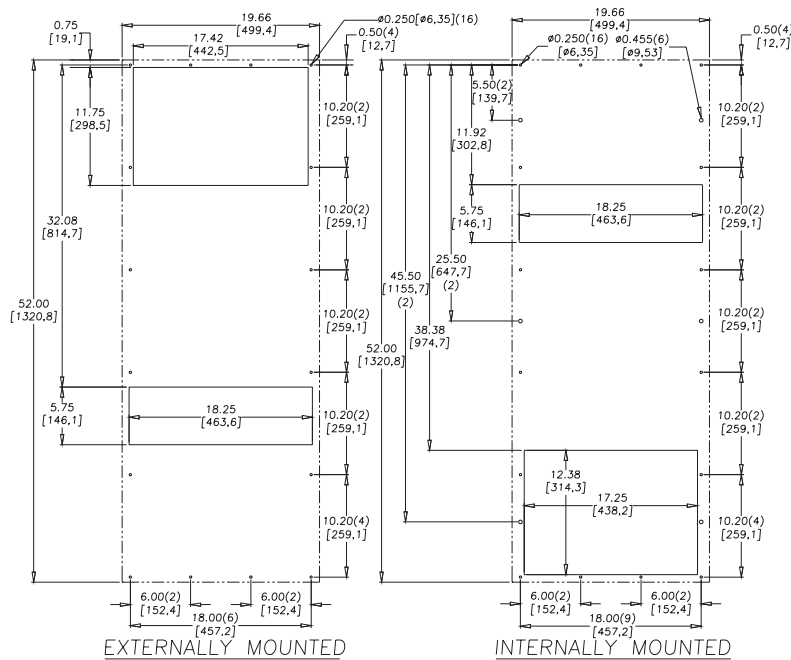

NOTES:
 1. DASHED LINES REPRESENT HEAT EXCHANGER.

Visit www.McLeanCoolingTech.com to download 2D and 3D CAD drawings into the overall design of your electronic system.

TX52 AC Models 83 W/°F (150 W/°C)

CLIMAGUARD HEX

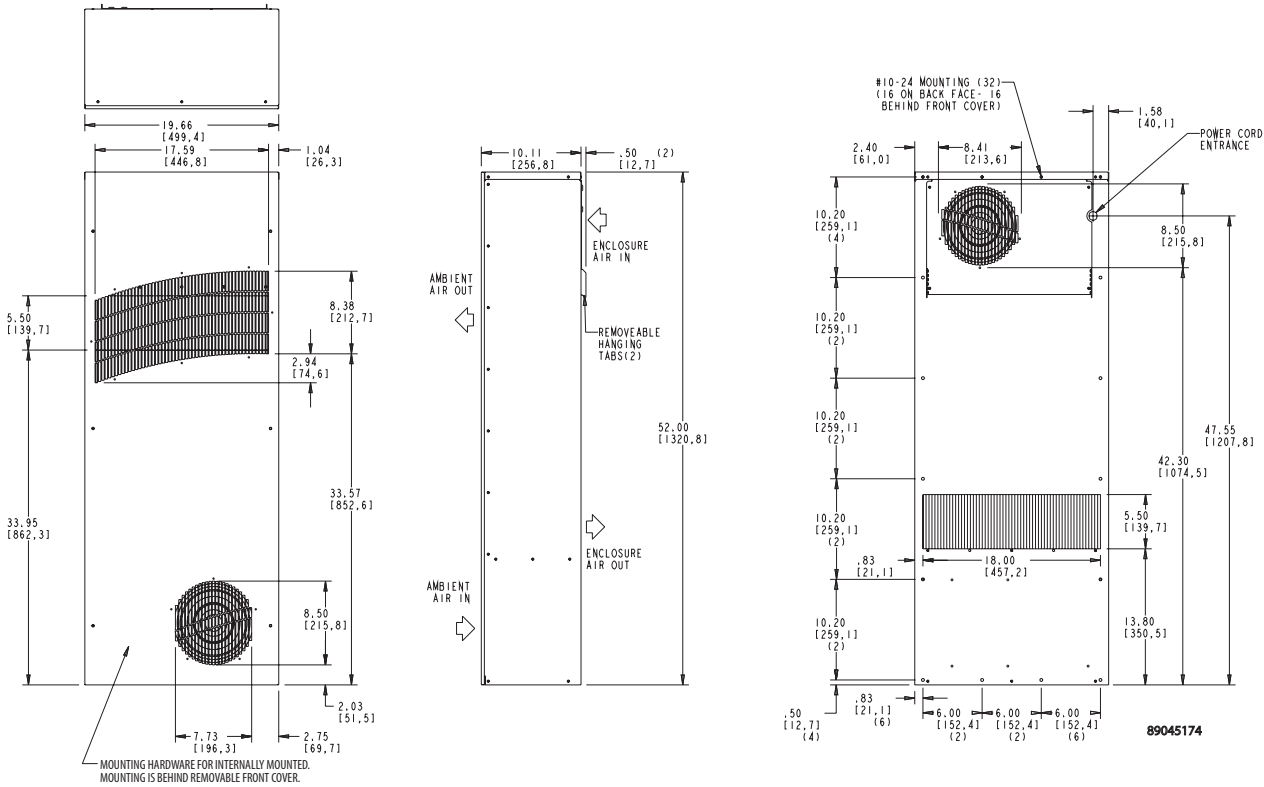

MOUNTING HARDWARE FOR INTERNALLY MOUNTED. MOUNTING IS BEHIND REMOVABLE FRONT COVER.

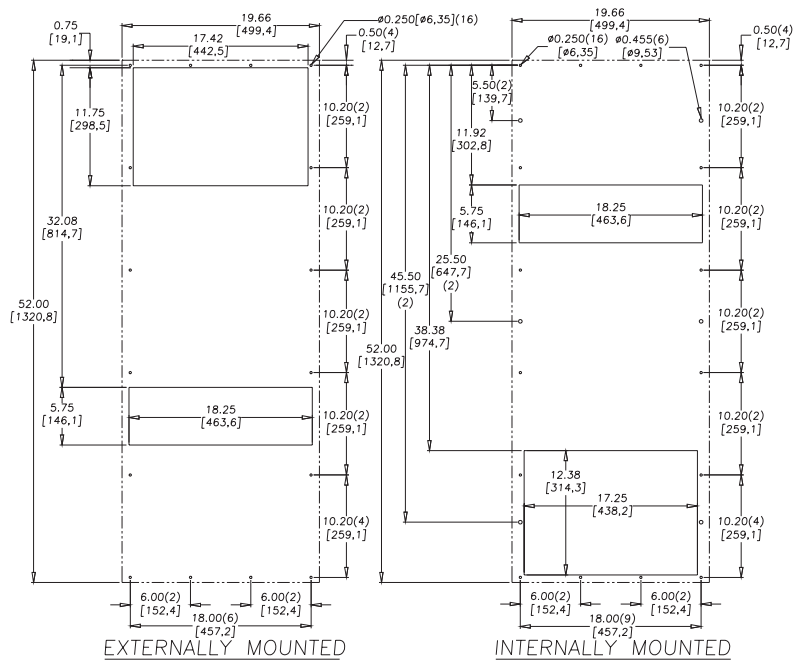

CUTOUT INSTRUCTIONS
 (AS VIEWED FROM OUTSIDE OF ENCLOSURE)

NOTES:
 T. DASHED LINES REPRESENT HEAT EXCHANGER.

Visit www.McLeanCoolingTech.com to download 2D and 3D CAD drawings into the overall design of your electronic system.

Notes

Engineered Protective Cooling Solutions

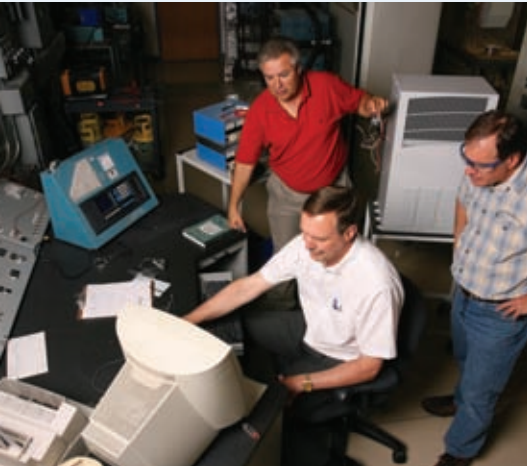

From simple blowers to packaged heat exchanger cores and sophisticated water-cooling devices, Pentair Technical Products designs and manufactures McLean engineered thermal management systems for virtually any electronics cooling application.

No one matches our flexibility, engineering experience and speed-to-market, thanks to these custom solution capabilities:

- 100+ combined years of thermal management engineering experience
- Rapid component prototyping
- Extensive in-house test facilities—CFD modeling, thermal cycling, salt fog, sound chamber and airflow
- UL client test data program for fast agency approvals

ENGINEERED SOLUTION PROCESS

Each design-to-spec cooling project is assigned a lead thermal engineer and supported by a dedicated cross-functional team. We then follow a proven development process from start to finish with every customer, ensuring timely and successful delivery of the engineered thermal solution.

MCLEAN ENGINEERED SOLUTION DEVELOPMENT PROCESS

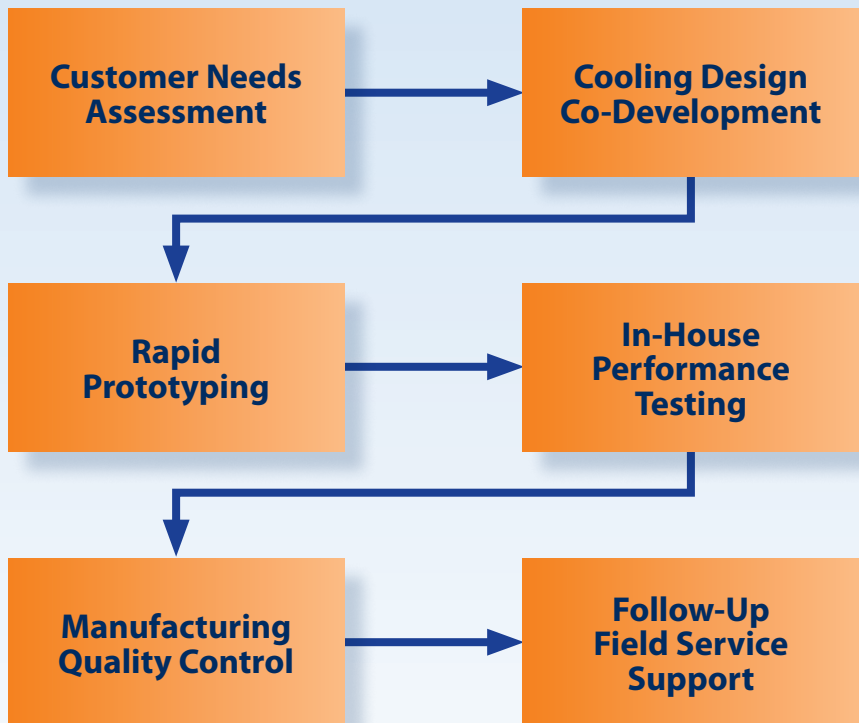

*Delivered with unparalleled flexibility,
engineering experience and speed-to-market*

ENGINEERED AIR CONDITIONERS

McLean engineered air conditioner solutions are designed and built by some of the most knowledgeable engineers in the industry. Using proven, environmentally friendly components, our experts can develop an energy-efficient, low-noise, reliable cooling system that fits your unique cooling requirements.

Pentair Technical Products also offers McLean engineered electronic controls to enhance performance and protect your electronics. These intelligent control systems range from low-cost airflow sensors to complex configurations with multiple sensors monitoring and reporting cooling status, faults and remote communications.

Your engineered unit will undergo our in-house "severe conditions" test to ensure it meets your exacting performance parameters. We will ensure each air conditioner meets UL, cUL, CSA, Bellcore, NEMA, IEC, European Safety and FCC compliances and standards. On-site UL certification is also available.

ENGINEERED HEAT EXCHANGER SOLUTIONS

Pentair Technical Products cooling experts work closely with your project team to design, develop and manufacture engineered heat exchanger solutions to your exact specifications. Engineered units are available with AC and DC high-efficiency air movers or DC-only with a battery backup.

We offer corrosion-resistant designs and finishes such as conversion coating, powder paint and chromate. Intelligent controls can be added with functions you specify, including speed control, fault indication, diagnostics, power conditioning, filtering and RS232 and I2C communications.

Using proprietary software to develop custom heat exchanger prototypes, we can test several unit dimensions and predict performance prior to build. And if your lead time is short, prototypes can often be manufactured in less than two weeks.



Model Number Index

Model Number	Page
330416GW010	117
330426GW012	117
330426GW014	117
CR230216G002	105
CR230226G002	105
CR230246G400	105
CR290216G002	108
CR290226G002	108
CR290246G400	108
CR290416G002	108
CR290426G002	108
CR290446G400	108
CR430616G002	111
CR430626G002	111
CR430646G400	111
CR430816-G002	111
CR430816GW010	119
CR430826G002	111
CR430826GWXXX	119
CR430846G400	111
G280416G050	21
G280416G051	21
G280416G100	21
G280416G101	21
G280416G102	21
G280416G150	21
G280416G151	21
G280426G050	21
G280426G051	21
G280426G100	21
G280426G101	21
G280426G102	21
G280426G150	21
G280426G151	21
G280446G050	21
G280446G051	21
G280446G100	21
G280446G101	21
G280446G102	21
G280616G050	21
G280616G051	21
G280616G100	21

Model Number	Page
G280616G101	21
G280616G102	21
G280616G150	21
G280616G151	21
G280626G050	21
G280626G051	21
G280626G100	21
G280626G101	21
G280626G102	21
G280626G150	21
G280626G151	21
G280646G050	21
G280646G051	21
G280646G100	21
G280646G101	21
G280646G102	21
G520816G050	27
G520816G051	27
G520816G100	27
G520816G101	27
G520816G102	27
G520816G150	27
G520816G151	27
G520826G050	27
G520826G051	27
G520826G100	27
G520826G101	27
G520826G102	27
G520826G150	27
G520826G151	27
G520846G050	27
G520846G051	27
G520846G100	27
G520846G101	27
G520846G102	27
G520846G150	27
G520846G151	27
G521216G050	27
G521216G051	27
G521216G100	27
G521216G101	27
G521216G102	27

Model Number Index

Model Number	Page
G521216G150	27
G521216G151	27
G521226G050	27
G521226G051	27
G521226G100	27
G521226G101	27
G521226G102	27
G521226G150	27
G521226G151	27
G521246G050	27
G521246G051	27
G521246G100	27
G521246G101	27
G521246G102	27
G521246G150	27
G521246G151	27
G572026G050	35
G572026G051	35
G572026G100	35
G572026G101	35
G572026G102	35
G572026G150	35
G572026G151	35
G572046G050	35
G572046G051	35
G572046G100	35
G572046G101	35
G572046G102	35
G572046G150	35
G572046G151	35
HB160816G040	99
HB160826G040	99
HB160846G040	99
LB110416GW008	121
LB110426GW010	121
M130116G1014	77
M130126G1008	77
M130146G400	77
M170216G009	79
M170226G004	79
M170246G400	79
M280216G013	81

Model Number	Page
M280226G004	81
M280246G400	81
M280416G007	82
M280426G032	82
M280446G400	82
M280616G005	83
M280626G005	83
M280646G400	83
M330416G010	85
M330426G009	85
M330446G400	85
M360616G307	87
M360626G306	87
M360646G400	87
M520446G002	89
M520646G002	89
M520846G002	89
M521046G002	89
MHB110216G306	95
MHB110226G306	95
MHB110246G400	95
MHB110416G307	96
MHB110426G306	96
MHB110446G400	96
T150116G150	43
T150126G150	43
T200216G150	46
T200226G150	46
T200246G400	46
T290416G150	49
T290426G150	49
T290446G400	49
T430616G150	52
T430626G150	52
T430646G400	52
T430816G150	54
T430826G150	54
T430846G400	54
T431016G150	56
T431026G150	56
T431046G400	56
T501226G150	59

Model Number	Page
T501246G400	59
T531926G150	62
T531946G400	62
T622226G150	65
T622246G400	65
T703626G150	68
T703646G400	68
T706026G150	71
T706046G400	71
TX231416100	145
TX231424100	145
TX231426100	145
TX231448100	145
TX332816100	149
TX332824100	149
TX332826100	149
TX332848100	149
TX385616100	151
TX385624-00	151
TX385626100	151
TX385648100	151
TX528316100	154
TX528324100	154
TX528326100	154
TX528348100	154
XR200416012	127
XR200426012	127
XR290816012	129
XR290826012	129
XR291816012	131
XR291826012	131
XR472416012	133
XR472426012	133
XR473516012	135
XR473526012	135
XR605516012	137
XR605526012	137
XR608416012	139
XR608426012	139

Abbreviations

"	Inch (1" = 2,54 cm)
AC	Alternating current
Amps	Ampere, electric current unit (A)
ANSI	American National Standards Institute
ANSI 61	Gray (RAL 7042)
ANSI 70	Light gray (RAL 7035)
BTU, Btu, BTUs	British Thermal Unit
C, °C	Degree Celsius ($= 1/1,8 \times [^{\circ}\text{F} - 32] = \text{K} - 273,15 \text{ }^{\circ}\text{C}$)
CE	Conformité Européenne, corresponds to EU guidelines
CFM, cfm	Cubic feet per minute (airflow volume)
CSA	Canadian Standards Association
cUL	Underwriters Laboratories Inc. (USA safety regulations), c - Canada
cUR	UL Recognized to Canadian (cUR) safety requirements
dB(A)	Decibels, volume level
DC	Direct current (unidirectional flow of electric charge)
F, °F	Degree Fahrenheit ($= 1,8 \times ^{\circ}\text{C} + 32$)
Ft., ft.	Foot (1 ft = 30,48 cm)
Hr., hr.	Hour (h)
Hz	Hertz, frequency unit
IP	Ingress Protection
IEC	International Electrotechnical Commission
in.	Inch (1 in. = 2,54 cm)
K	Kelvin ($= ^{\circ}\text{C} + 273,15 \text{ }^{\circ}\text{C}$)
lb.	Pound (1 lb. = 453,59237 g)
M, m	Meter
m ³ /h	Cubic meters per hour (airflow volume)
NEMA	National Electrical Manufacturers Association
square ft., sq ft.	Square foot (1 f ² = 929,0304 cm ²)
Telcordia GR-487	Generic Requirements for Electronic Equipment Cabinets
ton	The unit ton is used in refrigeration and air conditioning to measure heat absorption; 1 ton = 12000 BTU/Hr = 3,5 kW
UL	Underwriters Laboratories Inc. (USA safety regulations)
V, Voltage	Volt, electric current unit
W, Watt, Watts	Watt, unit of electric power

Global Field Repair Network *Over 1,000 field repair technicians worldwide*

Unlike some electronics cooling companies, Pentair Technical Products comes to you or wherever your system is deployed worldwide for repair services, eliminating the hassle and wait of sending your cooling unit back to headquarters.

We have over 1,000 certified field repair technicians worldwide who have been carefully screened to conduct warranty and non-warranty work on your McLean air conditioner, heat exchanger or air mover.

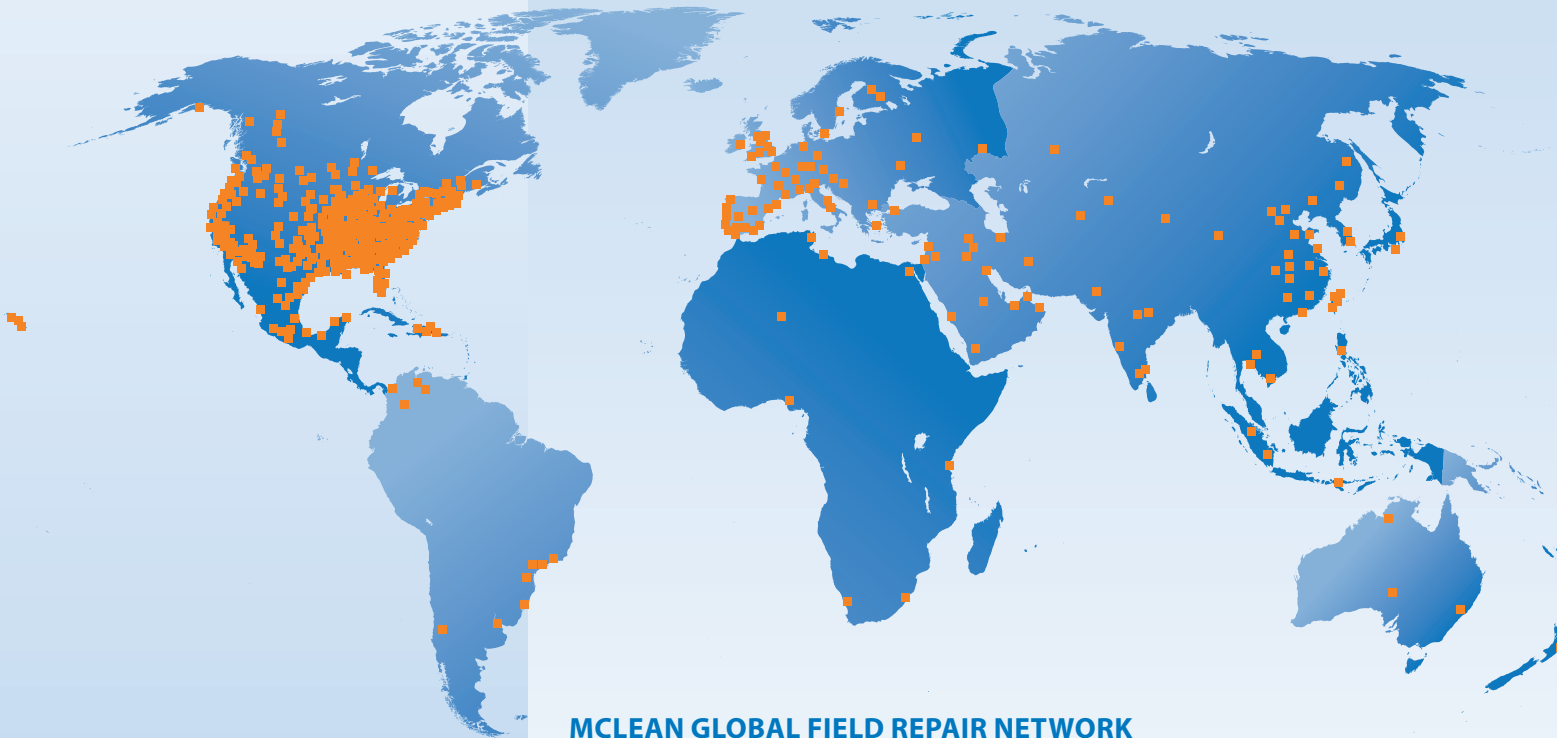

24/7 emergency repair services, extended warranties and preventative maintenance programs are also available. Check with McLean aftermarket services for details.

MCLEAN GLOBAL FIELD REPAIR NETWORK

Scheduling a McLean service repair technician is easy any day and time of the week.

BY PHONE

Please see back cover.

After business hours, call:
Johnson-Northwest (McLean Service Partner)
1-888-632-0092

ONLINE

McLeanCoolingTech.com/Service---Repair/Repair-Service-Request.aspx

Spare Parts Store

Safe, secure and easy to use

If you wish to repair a McLean cooling unit yourself, there are two ways to order spare parts—by phone and online.

BY PHONE

Please see back cover.

ONLINE

The McLean online spare parts store is completely safe, secure and easy to use. Simply visit McLeanCoolingTech.com then click on “Parts Store” in the main menu.

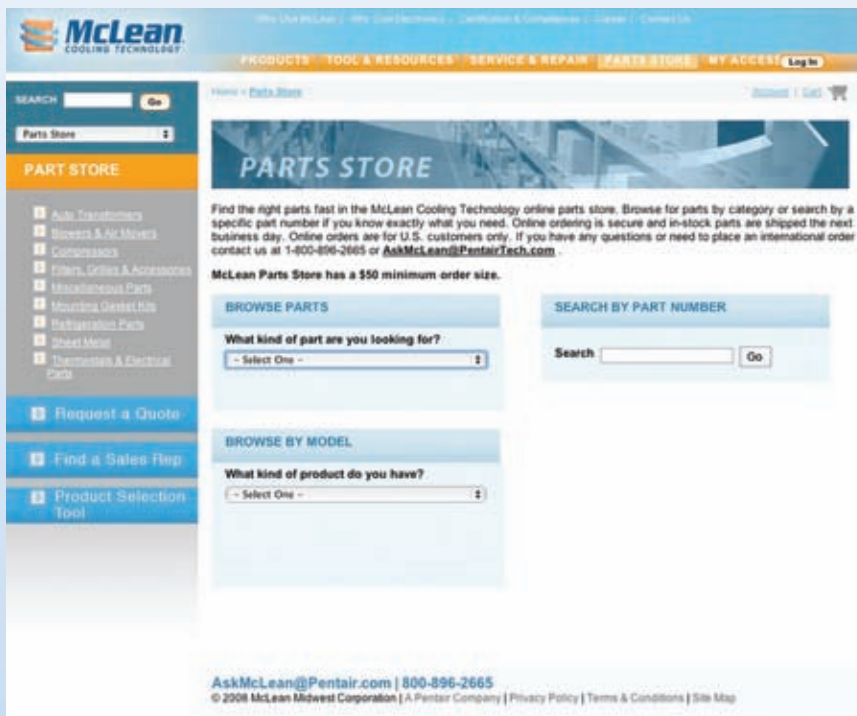

MCLEAN ONLINE SPARE PARTS STORE

You can search for your McLean spare parts by part number, model number or part category. The entire online shopping experience is user friendly. And at the end of the process, you may pay by credit card, or we can send you an invoice.

About Pentair Technical Products

Pentair Technical Products, a Pentair global business unit, is the leading provider of worldwide product and service solutions for enclosing, protecting and cooling electrical and electronic systems. Its industry-leading brands – Hoffman®, Schroff®, McLean® Cooling Technology, Calmark®, Birtcher®, Aspen Motion Technologies™ and Taunus™ – provide a broad variety of standard, modified and engineered solutions to the commercial, communications, energy, general electronics, industrial, infrastructure, medical, and security and defense markets.



NORTH AMERICA

Pentair Technical Products

2100 Hoffman Way
Anoka, MN 55303-1745
Tel. +1 (763) 421-2240

170 Commerce Drive
Warwick, RI 02886
Tel. +1 (401) 732-3770

7328 Trade Street
San Diego, CA 92121
Tel. +1 (858) 740-2400

1120 Rock Road
Radford, VA 24141
Tel. +1 (540) 639-4440

Pentair Technical Products

Hoffman Enclosures Inc.
111 Grangeway Ave., #504
Scarborough, ON M1H 3E9
Tel. +1 (416) 289-2770

Pentair Technical Products

Hoffman Enclosures Mexico,
S. de R.L. de C.V.
Arquimedes 33 Piso 1
Colonia Palmas Polanco
Mexico DF 11560
Tel. +52 55 5280 1449

SOUTH AMERICA

Pentair Technical Products

Pentair Taunus Electrometalurgica Ltda
Rua Joao Marcon, 165
18550.000 – Centro Boituva – SP Brazil
Tel. +55 15 3363 9100

EUROPE

Pentair Technical Products

Schroff GmbH
Langenalber Straße 96-100
75334 Straubenhardt, Germany
Tel. +49 (0)7082 794-0

Pentair Technical Products

Schroff UK Ltd.
Maylands Avenue
Hemel Hempstead
Herts HP2 7DE Great Britain
Tel. +44 (0)1442 240 471

Pentair Technical Products

Schroff SAS
Z.I. 4, rue du Marais
Boîte Postale 16
67660 Betschdorf, France
Tel. +33 (0)3 88 90 64 90

EUROPE

Pentair Technical Products

Schroff Scandinavia AB
Flygfältsgatan 11
P.O. Box 2003
12821 Skarpnäck, Sweden
Tel. +46 (0) 8 683 61 00

Pentair Technical Products

Schroff Scandinavia AB
Peräsimentie 8
FIN-03100 Nummela
Finland
Tel. +358 9 222 68 00

Pentair Technical Products

Schroff S.r.l.
Via Brughiera 1
20010 Pregnana Milanese (MI)
Italy
Tel. +39 02 932 714-1

Pentair Technical Products

Pentair Poland Sp.z o.o.
ul. Marynarska 21
PL-02-674 Warszawa Poland
Tel. +48 (0) 22 607 06 16

ASIA

Pentair Technical Products

21st Floor of Cloud Nine Plaza
No. 1118 West Yan'an Road
Changning District, Shanghai
P.R. China
Tel. +86 400 820 1133

Pentair Technical Products

India Pvt. Ltd.
Unit 1, Factory 2
(Sai Lakshmi Industrial Campus)
Kannamangala, Bidarahalli Hobli
Whitefield – Hoskote Road
Bangalore – 560 067
Tel. +91 80 2845 4640

Pentair Technical Products

Hoffman Schroff Pte Ltd.
18 Boon Lay Way
TradeHub 21, #04-110/111
Singapore 609966
Tel. +65 6795 2213

Pentair Technical Products

Schroff K.K.
Nisso No.13 Bldg. 4F
2-5-1 Shinyokohama
Kohoku-ku yokohama-shi
Kanagawa 222-0033 Japan
Tel. +81 (0)45 476 02 81