



Cheetah Speed System

Contractor Guide 2009





CHEETAH SPEED BOXES

Cheetah Speed Boxes (1 - 4 gang boxes) are made from high strength thermoplastic composites with specially designed speed anchor slots. Each slot has teeth molded to receive Cheetah Speed Anchors. As the speed anchor is pushed into the speed anchor slot, the teeth on the box and speed anchor engage in a zip-tie fashion to securely hold the anchor.

CHEETAH SPEED DEVICES

Cheetah devices (switches, receptacles, dimmers, GFCI, etc.) are pre-assembled with Cheetah Speed Anchors fastened with standard 6/32 screw (for easy removal or adjustment after installation). After you wire the Cheetah speed device (quickwire or side wire terminals), just push it in! The Cheetah Speed anchors zip-tie into the patented Cheetah Speed wallboxes - always centered and flush with the wall - requiring no screws for installation or finish!

CHEETAH SCREWLESS WALLPLATE

After the device is pushed (zip-tie) into the box, the Cheetah device is flush to the wall. Each Cheetah device has 4 holes which the Cheetah screwless wallplates simply snap into, flush with the wall. Cheetah matte finish wallplates are made from high strength thermoplastic. Each wallplate has eight (8) tabs to ensure a tight snug fit always flush with wall.

The patented Cheetah Speed System™ enables electrical devices, switches, receptacles, and wallplates to be installed without screws using a revolutionary speed anchor and snap & lock system, researched and developed with and by electricians. The Cheetah Speed System™ increases the speed of installation by up to 40% to 50%, and at the same time, offers the elegance, style, and designer look of screwless wallplates, at a very affordable price.

Cheetah saved me 680 hours in labor on just one project!

“Being in the Electrical Contracting business means you are in the labor business. If you can’t control your labor cost you can’t control your profits” said Rick Stocking President of 1st Electric Contractors in Lakewood, Colorado. “At 1st Electric we are continually searching for products that save labor without compromising quality. That’s exactly what we have found with Cheetah. Just by using Cheetah’s speed anchor devices and screw-less cover plates we are saving an average of 2-hours per unit and on our 340-unit project that’s 680 man hours. That’s just the obvious savings. With one less person we are still able to accelerate the schedule. I never imagined it was costing us so much money just to turn screws.”

Rick Stocking - President/Owner



PROJECT SPECS

Location:	Aurora, Colorado
Project:	Broadstone Southlands Apartments
Size:	340 Units

LABOR SAVINGS

Screws:	3 hours per unit
Cheetah:	1 hour per unit



Cheetah saved me \$11,450.00 in labor on just one project!

Tim Branham started Branham Electric, Inc. in 1991. Headquartered in St. Louis, Missouri; the company’s emphasis has always been super-custom homes and multi-family/mixed-use construction. Over the past few years Branham Electric has been the electrical contractor of choice for most of the areas’ large multi-family/mixed-use projects and many of St. Louis’ outstanding luxury homes. Tim knows construction and stresses that labor will either make or break any residential project!

“We recently tried Cheetah and could not believe the results. Our electricians are trained for speed, still we were more than pleasantly surprised when the Cheetah numbers came in.” Tim Branham - Owner



PROJECT SPECS

Project:	Southernside Apartments
Location:	St. Louis, MO
Size:	220 Units
Crew:	2 electricians/unit

LABOR SAVINGS

Screws:	150 minutes / unit
Cheetah:	100 minutes / unit



Cheetah saved me \$17,300.00 in labor!

At AEC Electric, speed is a passion and a hobby. Our slogan says it all, "Our Customers are the Winners"! We have used Cheetah on 3 large multi-family projects. In one project alone Cheetah saved me over \$9,600.00. We love the big boxes and the clean trim look. Our customers love the screw-less look, we love the speed!

"When it comes to speed, I am an avid fan. Cheetah has not only cut our labor costs significantly, but I am impressed with the quality and the product always looks awesome! We have cut our labor savings by 50% with Cheetah."

Jim Anderson - Owner



PROJECT SPECS

Project:	Sterling Pointe Apartments
Location:	Flagstaff, Arizona

LABOR SAVINGS

Screws:	4 hours / unit
Cheetah:	2 hours / unit

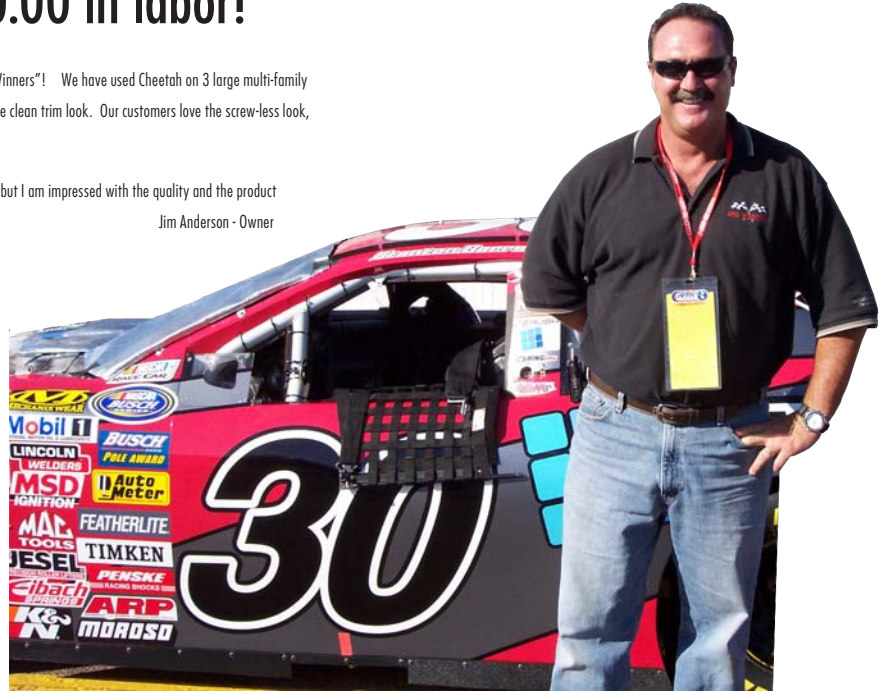

Cheetah saved me 480 hours in labor on just one project!

"Do the math! That is over 60 days labor savings on this project. I am saving over 2 hours per home. It adds up, I estimate we will save over \$15,000 in labor savings on this project alone. The labor savings are huge!"

Grant Henderson owns and runs Sidewinder Electric. He knows labor is everything. He is currently using Cheetah on a 240 home project in Safford, Arizona.

"The labor savings are proof. My crew completed their first 2,500 square foot house in Cheetah 45 minutes. The same crew takes 2 1/2 hours on an identical house with regular screws. I'm using Cheetah right now on 240 homes. It really is a no-brainer"

Grant Henderson - Sidewinder Electric

COMPANY SPECS

Avg Home Size:	1500 sq. ft.
Location:	Safford, Az
Builder:	Providence
Avg Crew per Home:	1 electricians

LABOR SAVINGS

Screws:	2.5 hours
Cheetah:	45 minutes



Cheetah Speed System

Frequently Asked Questions

How much more expensive are the Cheetah Speed System products?

A: In Florida, an electrical contractor compared Cheetah to the least expensive wallboxes, devices, and wallplates in that market. The “total home” cost of Cheetah screwless wallplates, devices and boxes were approx. \$22.50 more for the entire home. The electrician was able to trim the house out in less than 1 hour as compared to 4 hours using traditional devices. He saved product costs in less than 15 minutes.

If I install the Cheetah Speed System boxes, can I use standard screw devices?

A: Yes, just insert the speed anchors and screw away! The speed anchors “zip-tie” into the Cheetah Speed Boxes to turn the box into a standard non-metallic outlet box. Visit www.cheetahspeed.com to see how this is done.

How do I remove a device once it is inserted?

A: The speed anchors are fastened to a device using standard 6/32 screws (used on all electrical devices). Just unscrew the device. The speed anchors stay in the box (turning the box into a standard outlet box). You can either screw in a standard device, or using a screwdriver, punch the speed anchors through the teeth in the box and insert a new Cheetah-enabled device (with speed anchor pre-assembled). Visit www.cheetahspeed.com to see how this is done.

How strong are the speed anchors once they are inserted into the box?

A: The speed anchors have been tested to withstand a 50 lb. pull test per anchor. The UL standard requires only a 25 lb. pull test. The Speed Anchor teeth are one-directional to allow the anchor to “zip-tie” into the box, but not come out. To remove a speed anchor, simply punch (with a screwdriver) the speed anchor past the teeth and let it fall into the back of the wall.

What types of materials are used for the Cheetah Speed System products?

A: The Cheetah Speed Boxes are made from high strength thermoplastic. All Cheetah Boxes are 2-Hour Fire Rated for common wall installations. Cheetah devices and wall plates are made from high strength thermoplastic. All products are ETL tested and listed to UL standards through OSHA National Testing Laboratories Standards.

What happens if drywall mud gets in the speed anchor slots?

A: No worries, just use a screw driver to punch the mud through the slot. Easy to do and is actually faster than cleaning out standard screw boxes. Don't worry about hurting the teeth. If you notice a lot of mud in the boxes, fire the drywall crew!

Commitment to Customers

Our commitment is to deliver innovation, quality, and service to our customers. We are constantly enhancing and improving our products based upon feedback and use. We extensively field test our products to ensure “real-world” application and compliance. We rigorously test our products to industry standards through OSHA approved independent testing laboratories. We believe in principles of integrity, hard work, and high quality service.



Table of Contents

DECORA® & TOGGLE SWITCHES



- 15A-120VAC - Residential Grade Switches
- 20A-125VAC - Commercial / Spec Grade Switches
- 15A-120/277VAC - Combination Devices

Cheetah Decora and toggle switches complement any home décor. Matte finish device and wallplates blend into walls, hide finger prints and offer soft colors to accent your home. Cheetah switches come in Single Pole, 3-Way, and 4-Way configurations.

Quickwire slots (#14 wire only) or Side Wire terminals (#10, #12, or #14 wire) for easy installation.

PAGE 8-10

UL20 Standards Certified, ETL listed, CSA Certified.

DECORA® & DUPLEX RECEPTACLES



- 15A-125V & 20A-125V - Residential Grade Receptacles
- 15A-125V - Tamper Resistant & Weather Resistant Receptacles
- 15A-125V & 20A-125V - Commercial / Spec Grade Receptacles

Built with high strength thermoplastic resins, Cheetah receptacles are heavy duty and resilient to bending or breaking.

Quickwire slots (#14 wire only) for 15 amp or Side Wire terminals (#10, #12, or #14 wire) for 20 amp.

PAGE 11-13

UL498 Standards Certified, ETL listed, CSA Certified.

GFCI & DRYER/RANGE RECEPTACLES



- GFCI (15A-125V & 20A-125V) Standard - TR - WR
- 20 AMP - Single Receptacle (120V & 250V)
- 30A-125V/250V - Dryer Receptacle
- 50A-125V/250V - Range Receptacle

UL943 & UL498 Standards listed, CSA Certified.

PAGE 14-17

VOICE/DATA & AUDIO/VIDEO



- Wallplate TV & Phone
- Designer TV & Phone
- Keystone Mounts (1 - 6 ports)
- Keystone Jacks (Cat3/RJ11 , Cat 5e, F-Connector)
- HDMI & HDMI Keystone

UL1863 Standards Certified, ETL listed, CSA Certified.

PAGE 18-21

Decora® is a registered trademark of Leviton Manufacturing Co., Inc.

DIMMERS & FAN SPEED CONTROLS



- 600W/60 Hz Rotary
- 600W/60 Hz Slide Dimmers w/ preset (1 pole & 3 Way)
- 600W/60 Hz Smart Toggle Pre-Set Dimmer (1 pole)

Cheetah slide and toggle dimmers complement any home décor. Matte finish (devices and wallplates) blend into walls, hide finger prints, and offer soft colors to accent your home.

PAGE 22 - 25

UL1472 Standards Certified, ETL listed, CSA Certified.

SCREWLESS WALLPLATES

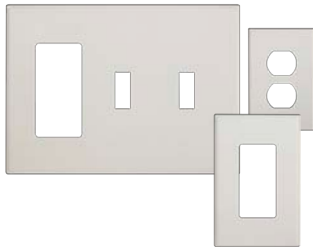

Screwless Wallplates

Unbreakable Thermoplastic Resins - Matte finish.

PAGE 26 - 29

UL514C Standards Certified, ETL listed, CSA Certified.

CHEETAH ELECTRICAL BOXES

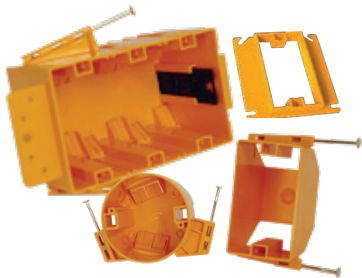

- 1 - 4 Gang Standard Size & Big A (oversize) Boxes
- Metal Stud Boxes (1 - 4 gang) w/ screws
- Cut-In / Work boxes (1 - 2 gang & datacom)
- Plaster/Mud Rings (fits 4" square metal boxes)

PAGE 30 - 33

UL514-C Standards Certified, ETL listed, CSA Certified.

CHEETAH ACCESSORIES



- Lampholders (Keyless, Pull Chain)
- Speed Anchors
- Universal Adapter Rings (retro standard screw devices)
- Blank Wallplate Adapter (for blank wallplates)
- Weatherproof Covers

PAGE 34 - 35

UL514-C Standards Certified, ETL listed, CSA Certified.

Toggle & Designer Switches

RESIDENTIAL CONSTRUCTION GRADE SWITCHES - SIDE & QUICKWIRE

Rated: 15A-120/277VAC Standard UL 20, Standard CSA-C22.2 No. 111 – General Use Switches



ELECTRICAL

Dielectric Voltage:	Withstands 1500V minimum
Operating Voltage:	120 - 277VAC
Overload:	Minimum 4.8 times rated current for 100 cycles
Current Interrupting:	Certified for current interrupting at full-rated current
Temperature Rise:	Max 30 Deg C. at full-rated current after 50 cycles
Endurance:	50,000 cycles minimum, resistive, inductive, tungsten filament lamp load (Fed Spec.)

MECHANICAL

Terminal Identification:	UL20 - Brass (hot), Black (hot)
Terminal Size:	#14 - #10 AWG Copper Conductor Only
Product ID:	Ratings marked permanently on device

ENVIRONMENTAL

Flammability:	UL94 V2
Operating Temp:	Max continuous +60 Deg C; Min -40 Deg C.

STANDARDS & CERTIFICATIONS

NEMA WD-1 & WD-6, ANSI C-73, UL 20, CSAC22.2 No.111

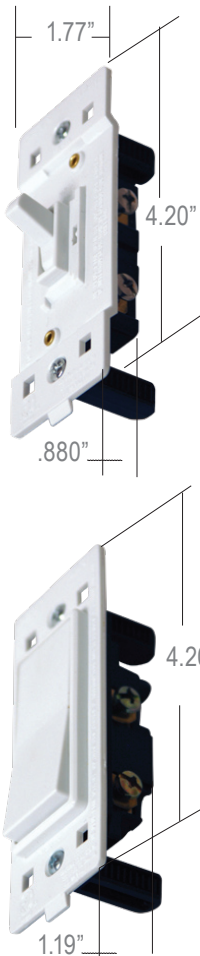

DESCRIPTION	CATALOG #	COLOR	
Single Pole Toggle Switch 15-AMP No Ground - See Appendix A 15A-120VAC	6000-C0A	ALMOND	
	6000-C0E	BLACK	
	6000-C0T	L ALMOND	
	6000-C0I	IVORY	
	6000-C0W	WHITE	
Three Way Toggle Switch 15-AMP No Ground - See Appendix A 15A-120VAC	6010-C0A	ALMOND	
	6010-C0E	BLACK	
	6010-C0T	L ALMOND	
	6010-C0I	IVORY	
	6010-C0W	WHITE	
Four Way Toggle Switch 15-AMP No Ground - See Appendix A 15A-120VAC	6020-C0A	ALMOND	
	6020-C0E	BLACK	
	6020-C0T	L ALMOND	
	6020-C0I	IVORY	
	6020-C0W	WHITE	
DESCRIPTION	CATALOG #	COLOR	
	Single Pole Decora Switch 15-AMP No Ground - See Appendix A 15A-120VAC	6030-C0A	ALMOND
		6030-C0E	BLACK
		6030-C0T	L ALMOND
		6030-C0I	IVORY
6030-C0W		WHITE	
Three Way Decora Switch 15-AMP No Ground - See Appendix A 15A-120VAC	6040-C0A	ALMOND	
	6040-C0E	BLACK	
	6040-C0T	L ALMOND	
	6040-C0I	IVORY	
	6040-C0W	WHITE	
Four Way Decora Switch 15-AMP No Ground - See Appendix A 15A-120VAC	6050-C0A	ALMOND	
	6050-C0E	BLACK	
	6050-C0T	L ALMOND	
	6050-C0I	IVORY	
	6050-C0W	WHITE	



Decora & Toggle Switches

COMMERCIAL/SPEC GRADE SWITCHES

Rated: 20A-120/277V Standard UL 20, Standard CSA-C22.2 No. 111 – General Use Snap Switches



ELECTRICAL

Dielectric Voltage:	Withstands 1500V minimum
Maximum Working Voltage:	277VAC
Overload:	Minimum 4.8 times rated current for 100 cycles
Current Interrupting:	Certified for current interrupting at full-rated current
Temperature Rise:	Max 30 Deg C. at full-rated current after 50 cycles
Endurance:	50,000 cycles minimum, resistive, inductive, tungsten filament lamp load (Fed Spec.)

MECHANICAL

Terminal Identification:	UL20 - Brass (hot), Black (hot)
Terminal Size:	#14 - #10 AWG Copper Conductor Only
Product ID:	Ratings marked permanently on device

ENVIRONMENTAL

Flammability:	UL94 V2
Operating Temp:	Max continuous +60 Deg C; Min -40 Deg C.

STANDARDS & CERTIFICATIONS

NEMA WD-1 & WD-6, ANSI C-73, UL 20, CSAC22.2 No.111



DESCRIPTION	CATALOG #	COLOR
Single Pole Toggle Switch	54524-C0T	L ALMOND
SPEC/COMMERCIAL GRADE	54524-C0I	IVORY
20A-120/277VAC	54524-C0W	WHITE
Three Way Toggle Switch	54523-C0T	L ALMOND
SPEC/COMMERCIAL GRADE	54523-C0I	IVORY
20A-120/277VAC	54523-C0W	WHITE



DESCRIPTION	CATALOG #	COLOR
Single Pole Decora Switch	05621-C0T	L ALMOND
SPEC/COMMERCIAL GRADE	05621-C0I	IVORY
	05621-C0W	WHITE
Three Way Decora Switch	05623-C0T	L ALMOND
SPEC/COMMERCIAL GRADE	05623-C0I	IVORY
20A-120/277VAC	05623-C0W	WHITE



Decora & Toggle Combination Switches

RESIDENTIAL GRADE COMBINATION SWITCHES - SIDE & QUICKWIRE

Rated: 15A-120/277VAC Standard UL 20, Standard CSA-C22.2 No. 111 – General Use Snap Switches



ELECTRICAL

Dielectric Voltage:	Withstands 1500V minimum
Maximum Working Voltage:	277VAC
Overload:	Minimum 4.8 times rated current for 100 cycles
Current Interrupting:	Certified for current interrupting at full-rated current
Temperature Rise:	Max 30 Deg C. at full-rated current after 50 cycles
Endurance:	50,000 cycles minimum, resistive, inductive, tungsten filament lamp load (Fed Spec.)

MECHANICAL

Terminal Identification:	UL20 - Brass (hot), Black (hot)
Terminal Size:	#14 - #10 AWG Copper Conductor Only
Product ID:	Ratings marked permanently on device

STANDARDS & CERTIFICATIONS

NEMA WD-1 & WD-6, ANSI C-73, UL 20, CSAC22.2 No.111



DESCRIPTION	CATALOG #	COLOR
Single Pole Toggle Combination Switch 15A-120VAC	6200-C0T	L ALMOND
	6200-C0I	IVORY
	6200-C0W	WHITE

CATALOG #	COLOR
6200-C0T	L ALMOND
6200-C0I	IVORY
6200-C0W	WHITE



DESCRIPTION	CATALOG #	COLOR
Single Pole Decora Combination Switch Individual Switches: 15A-120VAC Device Total: 20A-120V	01754-C0T	L ALMOND
	01754-C0I	IVORY
	01754-C0W	WHITE

CATALOG #	COLOR
01754-C0T	L ALMOND
01754-C0I	IVORY
01754-C0W	WHITE

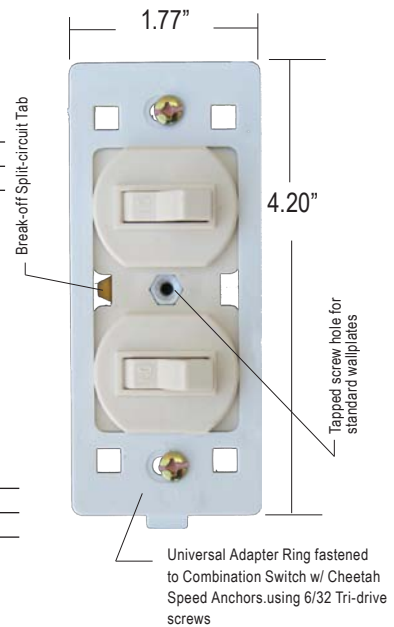

SWITCH WIRE DIAGRAM

1 Pole, 3-WAY, 4-WAY Switches Wire Diagrams

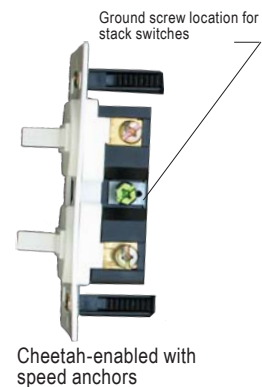
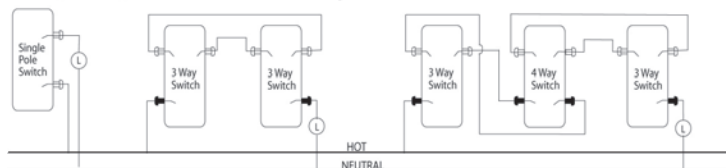

Designer & Duplex Receptacles

RESIDENTIAL GRADE RECEPTACLES - SIDE & QUICKWIRE

Rated: 15A and 20A-125V Standard UL 498, Standard CSA-C22.2 No. 42.2



ELECTRICAL

Dielectric Voltage: Withstands 2000V minimum
 Maximum Working Voltage: 120VAC
 Current Interrupting: Certified for current interrupting at full-rated current
 Temperature Rise: Max 30 Deg C. at full-rated current after 50 cycles

MECHANICAL

Terminal Identification: UL498 - Brass (hot), White (neutral), Green (ground)
 Terminal Size: #14 - #10 AWG Copper Conductor Only
 Product ID: Ratings marked permanently on device

ENVIRONMENTAL

Flammability: UL94 V2
 Operating Temp: Max continuous +60 Deg C; Min -40 Deg C.

STANDARDS & CERTIFICATIONS

NEMA WD-6, ANSI C-73, UL 498, CSAC22.2 No.42



DESCRIPTION	CATALOG #	COLOR
Duplex Receptacle 15A-125V	7000-C0A	ALMOND
	7000-C0E	BLACK
	7000-C0T	L ALMOND
	7000-C0I	IVORY
	7000-C0W	WHITE

DESCRIPTION	CATALOG #	COLOR
Duplex Receptacle 20A-125V	0CR20-C0L	L ALMOND
	0CR20-C0I	IVORY
	0CR20-C0W	WHITE



DESCRIPTION	CATALOG #	COLOR
Decora Receptacle 15A-125V	7020-C0A	ALMOND
	7020-C0E	BLACK
	7020-C0T	L ALMOND
	7020-C0I	IVORY
	7020-C0W	WHITE

DESCRIPTION	CATALOG #	COLOR
Decora Receptacle 20A-125V	16342-C0L	L ALMOND
	16342-C0I	IVORY
	16342-C0W	WHITE

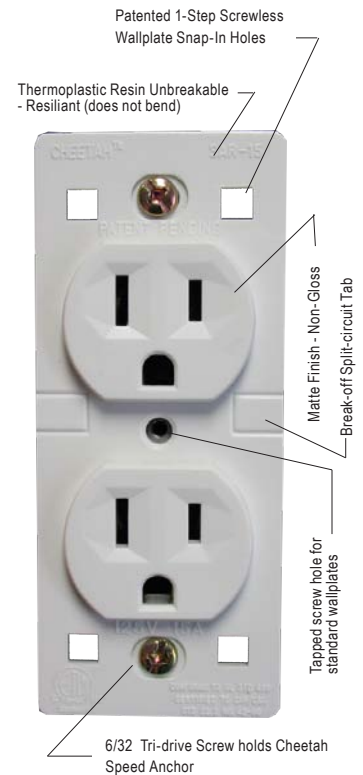

6/32 Tri-drive Screw holds Cheetah Speed Anchor

- Standard Vertical Adjustment (crooked box/stud installation)
- Remove to service device (speed anchor stays in box)

Tamper Resistant Receptacles

DUPLEX & DESIGNER RESIDENTIAL GRADE RECEPTACLES - 2008 NEC COMPLIANT

Rated: 15A and 20A-125V Standard UL 498, Standard CSA-C22.2 No. 42.2



ELECTRICAL

Dielectric Voltage:	Withstands 2000V minimum
Maximum Working Voltage:	120VAC
Current Interrupting:	Certified for current interrupting at full-rated current
Temperature Rise:	Max 30 Deg C. at full-rated current after 50 cycles

MECHANICAL

Terminal Identification:	UL498 - Brass (hot), White (neutral), Green (ground)
Terminal Size:	#14 - #10 AWG Copper Conductor Only
Product ID:	Ratings marked permanently on device

ENVIRONMENTAL

Flammability:	UL94 V2
Operating Temp:	Max continuous +60 Deg C; Min -40 Deg C.

STANDARDS & CERTIFICATIONS

NEMA WD-6, ANSI C-73, UL 498, CSAC22.2 No.42

2008 NEC TAMPER RESISTANT RECEPTACLES

Tamper Resistant Receptacles protect children from electrical injuries due to inserting foreign objects into receptacles. A shutter mechanism inside the receptacle blocks access to the contacts unless a two-prong plug is inserted. Our TR Receptacles meet the 2008 NEC Code, Section 406.11, specifying that all 15A and 20A receptacles installed in dwelling units in accordance with Section 210.52 be listed tamper-resistant. The TR symbol on the receptacle face assures compliance.



DESCRIPTION	CATALOG #	COLOR
TR Duplex Receptacle 15A-125V	T5320-C0E	BLACK
	T5320-C0T	L ALMOND
	T5320-C0I	IVORY
	T5320-C0W	WHITE



TR Duplex Receptacle 20A-125V	TBR20-C0E	BLACK
	TBR20-C0T	L ALMOND
	TBR20-C0I	IVORY
	TBR20-C0W	WHITE



DESCRIPTION	CATALOG #	COLOR
TR Decora Receptacle 15A-125V	T5325-C0E	BLACK
	T5325-C0T	L ALMOND
	T5325-C0I	IVORY
	T5325-C0W	WHITE



TR Decora Receptacle 20A-125V	TDR20-C0E	BLACK
	TDR20-C0T	L ALMOND
	TDR20-C0I	IVORY
	TDR20-C0W	WHITE



Weather & Tamper Resistant Receptacles

DUPLEX RESIDENTIAL GRADE TR/WR RECEPTACLES - 2008 NEC COMPLIANT

Rated: 15A and 20A-125V Standard UL 498, Standard CSA-C22.2 No. 42.2

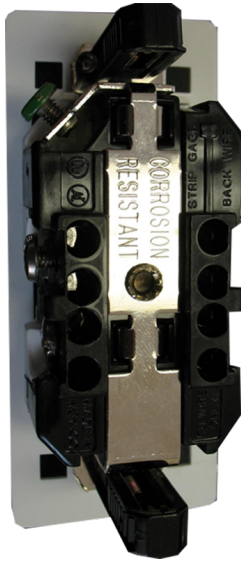

ELECTRICAL

Dielectric Voltage:	Withstands 2000V minimum
Maximum Working Voltage:	120VAC
Current Interrupting:	Certified for current interrupting at full-rated current
Temperature Rise:	Max 30 Deg C. at full-rated current after 50 cycles

MECHANICAL

Terminal Identification:	UL498 - Brass (hot), White (neutral), Green (ground)
Terminal Size:	#14 - #10 AWG Copper Conductor Only
Product ID:	Ratings marked permanently on device

ENVIRONMENTAL

Flammability:	UL94 V2
Operating Temp:	Max continuous +60 Deg C; Min -40 Deg C.

STANDARDS & CERTIFICATIONS

NEMA WD-6, ANSI C-73, UL 498, CSAC22.2 No.42



DESCRIPTION	CATALOG #	COLOR
TR/WR Duplex Receptacle 15A-125V	W5320-TCT	L ALMOND
	W5320-TCI	IVORY
	W5320-TCW	WHITE
LEVITON		
TR/WR Decora Receptacle 15A-125V	W5325-TCT	L ALMOND
	W5325-TCI	IVORY
	W5325-TCW	WHITE
LEVITON		

2008 NEC TAMPER RESISTANT & WEATHER RESISTANT RECEPTACLES

Tamper Resistant Receptacles protect children from electrical injuries due to inserting foreign objects into receptacles. A shutter mechanism inside the receptacle blocks access to the contacts unless a two-prong plug is inserted. Our TR Receptacles meet the 2008 NEC Code, Section 406.11, specifying that all 15A and 20A receptacles installed in dwelling units in accordance with Section 210.52 be listed tamper-resistant. The TR symbol on the receptacle face assures compliance.

Tamper/Weather Resistant Receptacles meet UL 498 requirements as well as Sections 406.8 (weather resistant) and 406.11 (tamper resistant) of the 2008 NEC Code. Built of UV stabilized thermoplastic with high cold impact resistance, they're ideal in damp or wet locations. The WR symbol on receptacle face and TR symbol on straps assure compliance.

GFCI Receptacles

GFCI RECEPTACLES

Rated: 15A and 20A-125V Standard UL 498, UL 943 GFCI Standard CSA-C22.2 No. 42.2



ELECTRICAL

Dielectric Voltage: Withstands 1500V minimum
 Maximum Working Voltage: 120 VAC
 Current Interrupting: Certified for current interrupting at full-rated current
 Temperature Rise: Max 30 Deg C. at full-rated current after 50 cycles

MECHANICAL



Terminal Identification: UL498 - Brass (hot), White (neutral), Green (ground)
 Terminal Size: #14 - #12 AWG Copper Conductor Only
 Product ID: Ratings marked permanently on device

ENVIRONMENTAL

Flammability: UL94 V2
 Operating Temp: Max continuous +60 Deg C; Min -40 Deg C.

STANDARDS & CERTIFICATIONS

NEMA WD-6, ANSI C-73, UL498, CSAC22.2 No.42

DESCRIPTION	CATALOG #	COLOR
GFCI with LED Indicator Light (NEMA 5-15R) 15A-125V @ Receptacle, 20A-125V Feed Through 	7599-C0E	BLACK
	7599-C0T	L ALMOND
	7599-C0I	IVORY
	7599-C0W	WHITE
GFCI with LED Indicator Light (NEMA 5-20R) 20A-125V @ Receptacle, 20A-125V Feed Through 	7899-C0E	BLACK
	7899-C0T	L ALMOND
	7899-C0I	IVORY
	7899-C0W	WHITE

Features and Benefits

- * Automatically test the GFCI every time the RESET button is pushed in. The GFCI will not reset if the GFCI circuit is not functioning properly.
- * By blocking reset of the GFCI if protection has been compromised, SmartLockPRO® reduces the possibility of end-users incorrectly assuming that a reset GFCI outlet is providing ground fault protection when it actually is not.
- * A line-load reversal diagnostic feature is provided which prevents the GFCI from being reset and stops power from being fed to the GFCI receptacle face or through to downstream devices. A green LED indicator on the GFCI's face also illuminates to alert the installer to the line-load wiring reversal.
- * The trip latch mechanism in SmartLockPro GFCIs is a one piece "T" design for efficient operation
- * There are 4 sets of contacts for load terminals and face. SmartLockPRO GFCIs use a patented bifurcated bridge contact for efficient operation
- * Trip threshold meets or exceeds UL requirements for tripping time
- * Improved immunity to high-frequency noise reduces nuisance tripping

SmartLockPRO® is a registered trademark of Leviton Manufacturing Co., Inc.

GFCI Receptacles - Tamper Resistant & Weather Resistant

TR/WR GFCI RECEPTACLES - 2008 NEC COMPLIANT

Rated: 15A and 20A-125V Standard UL 498, UL 943 GFCI Standard CSA-C22.2 No. 42.2



ELECTRICAL

Dielectric Voltage: Withstands 2000V minimum
 Maximum Working Voltage: 120 VAC
 Current Interrupting: Certified for current interrupting at full-rated current
 Temperature Rise: Max 30 Deg C. at full-rated current after 50 cycles

MECHANICAL

Terminal Identification: UL498 - Brass (hot), White (neutral), Green (ground)
 Terminal Size: #14 - #10 AWG Copper Conductor Only
 Product ID: Ratings marked permanently on device

ENVIRONMENTAL

Flammability: UL94 V2
 Operating Temp: Max continuous +60 Deg C; Min -40 Deg C.

STANDARDS & CERTIFICATIONS

NEMA WD-6, ANSI C-73, UL 498, CSAC22.2 No.42



DESCRIPTION	CATALOG #	COLOR
Tamper-Resistant GFCI with LED Indicator Light 15A - (NEMA 5-15 R)	T7599-C0E	BLACK
	T7599-C0T	L ALMOND
	T7599-C0I	IVORY
	T7599-C0W	WHITE



Tamper-Resistant GFCI with LED Indicator Light 20A - (NEMA 5-20 R)	T7899-C0E	BLACK
	T7899-C0T	L ALMOND
	T7899-C0I	IVORY
	T7899-C0W	WHITE



DESCRIPTION	CATALOG #	COLOR
Tamper-Resistant GFCI with LED Indicator Light 15A - (NEMA 5-15 R)	W7599-TCE	BLACK
	W7599-TCW	WHITE

Weather-Resistant - OUTDOOR GRADE



Tamper-Resistant GFCI with LED Indicator Light 20A - (NEMA 5-20 R)	W7899-TCE	BLACK
	W7899-TCW	WHITE

Weather-Resistant - OUTDOOR GRADE



DRYER / RANGE RECEPTACLES

DRYER/RANGE & SIMPLEX RECEPTACLES

Dryer/Range Rated: 30A and 50A-125/250V Standard UL 498 Standard CSA-C22.2 No. 42.2



ELECTRICAL

Dielectric Voltage: Withstands 2000V minimum
 Maximum Working Voltage: 208/240 VAC
 Current Interrupting: Certified for current interrupting at full-rated current
 Temperature Rise: Max 30 Deg C. at full-rated current after 50 cycles

MECHANICAL

Terminal Identification: UL498 - Brass (hot), White (neutral), Green (ground)
 Terminal Size: Up to 4AWG Copper Conductor Only
 Product ID: Ratings marked permanently on device

ENVIRONMENTAL

Flammability: UL94 V2
 Operating Temp: Max continuous +60 Deg C; Min -40 Deg C.

STANDARDS & CERTIFICATIONS

NEMA WD-6, ANSI C-73, UL 498, CSAC22.2 No.42



DESCRIPTION	CATALOG #	COLOR
30A-125/250V Receptacle (NEMA 14-30R) - CU & AL Rated Stainless Steel Wallplate included	278-C	Stainless Steel



DESCRIPTION	CATALOG #	COLOR
50A-125/250V Receptacle (NEMA 14-50R) - CU & AL Rated Stainless Steel Wallplate included	279-C	Stainless Steel



SINGLE RECEPTACLES

SINGLE RECEPTACLES 120V & 250V

Rated: 15A and 20A-120V and 250V Standard UL 498 Standard CSA-C22.2 No. 42.2



ELECTRICAL

Dielectric Voltage: Withstands 2000V minimum
 Maximum Working Voltage: 120 VAC
 Current Interrupting: Certified for current interrupting at full-rated current
 Temperature Rise: Max 30 Deg C. at full-rated current after 50 cycles

MECHANICAL

Terminal Identification: UL498 - Brass (hot), White (neutral), Green (ground)
 Terminal Size: Up to 4AWG Copper Conductor Only
 Product ID: Ratings marked permanently on device

STANDARDS & CERTIFICATIONS

NEMA WD-6, ANSI C-73, UL 498, CSAC22.2 No.42



DESCRIPTION	CATALOG #	COLOR
Tamper-Resistant Single Receptacle Screwless Wallplate Included 15A-125V	T5015-C0T	L ALMOND
	T5015-C0I	IVORY
	T5015-C0W	WHITE



DESCRIPTION	CATALOG #	COLOR
Tamper-Resistant Single Receptacle Screwless Wallplate Included 20A-125V	T5801-C0T	L ALMOND
	T5801-C0I	IVORY
	T5801-C0W	WHITE



DESCRIPTION	CATALOG #	COLOR
Single Receptacle Screwless Wallplate Included 20A - 250V	5461-C0T	L ALMOND
	5461-C0I	IVORY
	5461-C0W	WHITE



Data & Audio Solutions

WALLPLATE TELEPHONE/COAX

UL 1846 Standard - Low Voltage Data Communications



Datacom / Telephone

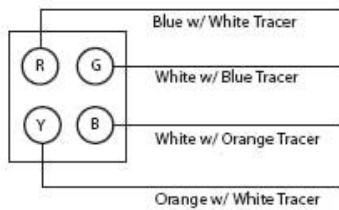

ELECTRICAL

Current Interrupting: Meets FCC Part 68 - UL 1863
 Temperature Rise: Max 30 Deg C. at full-rated current after 50 cycles

MECHANICAL

Terminal Identification: T568A and T568B wiring patterns
 Wiring: Fully compliant with published TIA-568-C0A requirements

ENVIRONMENTAL

Flammability: UL94 V2
 Operating Temp: Max continuous +60 Deg C; Min -40 Deg C.

STANDARDS & CERTIFICATIONS

NEMA WD-6, ANSI C-73, UL 498, CSAC22.2 No.42



High Quality Screw Connectors
 Easy Wire Openings
 High Strength Wire Fittings

WALLPLATE TELEPHONE AND COAX DEVICES



DESCRIPTION	CATALOG #	COLOR
Wallplate Telephone Jack	CH249-00T	L ALMOND
	CH249-00I	IVORY
	CH249-00W	WHITE

Wallplate Coax Cable Jack	CH281-00T	L ALMOND
	CH281-00I	IVORY
	CH281-00W	WHITE

Wallplate Telephone / Coax Jack	CH259-00T	L ALMOND
	CH259-00I	IVORY
	CH259-00W	WHITE

DESIGNER TELEPHONE/COAX

UL 1846 Standard - Low Voltage Data Communications

DESIGNER TELEPHONE AND COAX DEVICES



DESCRIPTION	CATALOG #	COLOR
Designer Telephone Jack	CH149-00A	ALMOND
	CH149-00E	BLACK
	CH149-00T	L ALMOND
	CH149-00I	IVORY
	CH149-00W	WHITE
Designer Coax Cable Jack	CH181-00A	ALMOND
	CH181-00E	BLACK
	CH181-00T	L ALMOND
	CH181-00I	IVORY
	CH181-00W	WHITE
Designer Telephone / Coax Jack	CH159-00A	ALMOND
	CH159-00E	BLACK
	CH159-00T	L ALMOND
	CH159-00I	IVORY
	CH159-00W	WHITE

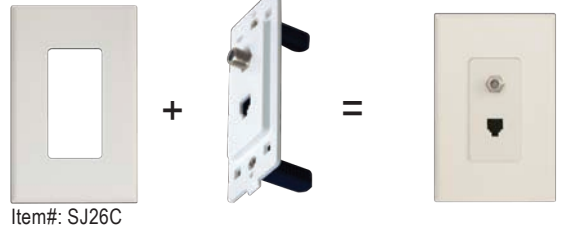

** REQUIRES A DESIGNER WALLPLATE (ITEM# SJ26C)

Datacom Box Installations

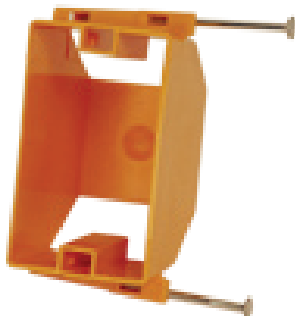

Datacom Nail-on Box
Item# 3005C



Low Voltage Cut-In Bracket Assembled
Item# 4007C



Low Voltage / High Voltage Divider
Item# 4003C (Standard Box)
Item# 4004C (Big A Box)

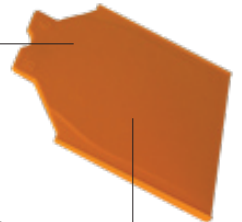

KEYSTONE MOUNT DEVICES



DESCRIPTION	CATALOG #	COLOR
1 Port Datacom Keystone Mount	5000C-C0A	ALMOND
	5000C-C0B	BLACK
	5000C-CAL	L ALMOND
	5000C-C0I	IVORY
	5000C-C0W	WHITE
2 Port Datacom Keystone Mount	5010C-C0A	ALMOND
	5010C-C0B	BLACK
	5010C-CAL	L ALMOND
	5010C-C0I	IVORY
	5010C-C0W	WHITE
3 Port Datacom Keystone Mount	5020C-C0A	ALMOND
	5020C-C0B	BLACK
	5020C-CAL	L ALMOND
	5020C-C0I	IVORY
	5020C-C0W	WHITE
4 Port Datacom Keystone Mount	5030C-C0A	ALMOND
	5030C-C0B	BLACK
	5030C-CAL	L ALMOND
	5030C-C0I	IVORY
	5030C-C0W	WHITE
6 Port Datacom Keystone Mount	5040C-C0A	ALMOND
	5040C-C0B	BLACK
	5040C-CAL	L ALMOND
	5040C-C0I	IVORY

KEYSTONE JACKS - SNAP-IN CONNECTORS



DESCRIPTION	CATALOG #	COLOR
Cat 3 - RJ11 Telephone	41108-RW3	WHITE
	41108-RT3	L ALMOND
	41108-RI3	IVORY
Cat 5e Snap-In Jack 4-Pair - 8 wire conductor Category 5e T568A and T568B wiring patterns	5G108-RW5	WHITE
	5G108-RT5	L ALMOND
	5G108-RI5	IVORY
F-Connector/Coax Nickel Plated, Feedthrough	41084-FWF	WHITE
	41084-FTF	L ALMOND
	41084-FIF	IVORY



Data & Audio Solutions

HDMI - HIGH DEFINITION MEDIA INTERFACE W/KEYSTONE PORTS

UL 1846 Standard - Low Voltage Data Communications



GOLD PLATED HIGH DEFINITION HDMI CONNECTOR

ELECTRICAL

Type A HDMI connector (19 pins)
 Support all SDTV, EDTV and HDTV modes
 HDMI Port Dimensions: 13.9 mm wide by 4.45 mm high.
 Type A is electrically compatible with single-link DVI-D

MECHANICAL

The Type A HDMI connector supports up to 165MHz of video bandwidth at 24 bits per pixel. The audio format can support stereo, surround sound, and up to eight channels of one bit audio.

TYPE A CONNECTOR PIN OUT

PIN	SIGNAL
1	TMDS Data2+
2	TMDS Data2 Shield
3	TMDS Data2-
4	TMDS Data1+
5	TMDS Data1 Shield
6	TMDS Data1-
7	TMDS Data0+
8	TMDS Data0 Shield
9	TMDS Data0-
10	TMDS Clock+
11	TMDS Clock Shield
12	TMDS Clock-
13	CEC
14	RESERVED
15	SCL
16	SDA
17	DDC/CEC Ground
18	+5 V Power
19	Hot Plug Detect

DESIGNER HDMI/KEYSTONE



DESCRIPTION	CATALOG #	COLOR
Designer HDMI Connector	5170C-CAL	L ALMOND
	5170C-COI	IVORY
	5170C-COW	WHITE



DESCRIPTION	CATALOG #	COLOR
Designer HDMI w/ 4 Port Keystone	5180C-CAL	L ALMOND
	5180C-COI	IVORY
	5180C-COW	WHITE

IDEAL MULTI-MEDIA/GAMING PORT



Cheetah HDMI w/Keystone Mounts offer flexibility in a single gang installation for HDMI, component and composite video configurations ideal for a classily screwless look. Ideal for a universal gaming solution.

Gold Plated



19 Pin HDMI - Front Connector



Back of HDMI Connector

Lighting Controls - TOGGLE DIMMERS

ELECTRONIC SMART PRE-SET DIMMERS- 600W - 60HZ

Rated: 120V - 60 Hz Standard UL 1472 Standard CSA-C22.2 No. 184.1



ELECTRICAL

Voltage: 120 Volt AC - 60 Hz
 Load Type: Incandescent
 Load Rating: 600 Watts
 Filtering: Radio Frequency Interference Filtering
 De-Rating: Finned Aluminum Tabbed - 600W/500W/400W
 Pre-Set: Electronic
 Construction: Printed Solid-State Circuit Board

MECHANICAL

Size: Fits single and multi-gang NEMA wall boxes)
 Wiring: 6" color-coded Leads Pre-Stripped - 16 gauge
 Heat Sink: Wide Mount Aluminum Fins
 Back Body: Unbreakable ABS

ENVIRONMENTAL

Flammability: UL94 V2
 Operating Temp: Indoor Use Only

STANDARDS & CERTIFICATIONS

NEMA WD-6, ANSI C-73, UL 1472, CSAC22.2 No. 184.1

DESCRIPTION	CATALOG #	COLOR
Smart Toggle Dimmer - Single Pole	6250-C0T	L ALMOND
	6250-C0I	IVORY
	6250-C0W	WHITE

HOW IT WORKS



ON/OFF (energy efficient)

- Lights Ramp UP Slowly to Smart Set
- Lights Ramp DOWN Slowly

DIM LIGHTS (no ugly slide)

- Hold/Press toggle switch in UP position
- Lights cycle through the dimmer range
- SMART SET: Release Toggle Switch at desired smart setting

STYLE & QUALITY

- Matte finish (no glossy fingerprints)
- SCREWLESS Wallplate Included
- Easy to Clean (dishwasher safe)
- High Strength Lexan Resin
- UL Standards Tested

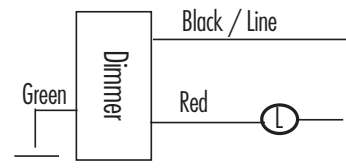

Insulated wires connect to Line (usually black) and load (light).

1. Connect green dimmer ground wire to bare copper ground in outlet box.
2. Fasten black dimmer wire to black/line wire.
3. Fasten Red dimmer wire to remaining wire (load).

Designed to look like a standard switch! NO more ugly slides to clean or look at!

Lighting controls - FAN SPEED CONTROL & OCCUPANCY SENSOR

FAN SPEED CONTROL & OCCUPANCY SENSOR

Rated: 1.5A - 120VAC Standard UL 1472 Standard CSA-C22.2 No. 184.1



ELECTRICAL

Filtering: Radio Frequency Interference Filtering
 Pre-Set: Electronic
 Construction: Printed Solid-State Circuit Board

MECHANICAL

Size: Fits single and multi-gang NEMA wall boxes)
 Heat Sink: Wide Mount Aluminum Fins
 Back Body: Unbreakable ABS

ENVIRONMENTAL

Flammability: UL94 V2
 Operating Temp: Indoor Use Only

STANDARDS & CERTIFICATIONS

NEMA WD-6, ANSI C-73, UL 1472, CSAC22.2 No. 184.1



DESCRIPTION	CATALOG #	COLOR
Fan Speed Control - Quiet with LED locator Neutral Required	IPF01-CLZ	WHITE Ivory & Light Almond Included.
1.5A - 120VAC 1 Pole & 3 Way Configuration Color White with Light Almond and Ivory color kits included		



DESCRIPTION	CATALOG #	COLOR
Occupancy Sensor, 1800W@120VAC - 60Hz	IPP15-C0L	L ALMOND
Single Pole & 3 Way Configuration	IPP15-C0I	IVORY
180 Degree field-of-view 900 sq ft coverage	IPP15-C0W	WHITE
California Title 24 compliant Passive Infrared - Time Adjustment: 30s - 30m		



Lighting Controls - Dimmers

SLIDE DIMMER WITH PRE-SET & LED - 600W - 60HZ

Rated: 120V - 60 Hz Standard UL 1472 Standard CSA-C22.2 No. 184.1

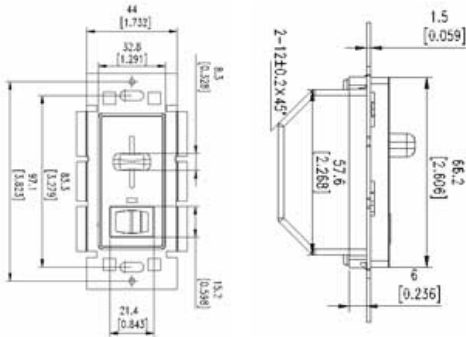

ELECTRICAL

Voltage:	120 Volt AC - 60 Hz
Load Type:	Incandescent
Load Rating:	700 Watts
Filtering:	Radio Frequency Interference Filtering
De-Rating:	Finned Aluminum Tabbed - 600W/500W/400W
Pre-Set:	On/Off
Construction:	Printed Solid-State Circuit Board

MECHANICAL

Size:	Fits single and multi-gang NEMA wallboxes
Wiring:	6" color-coded Leads Pre-Stripped - 16 gauge
Heat Sink:	Wide Mount Aluminum Fins
Back Body:	Unbreakable ABS

ENVIRONMENTAL

Flammability:	UL94 V2
Operating Temp:	Indoor Use Only

STANDARDS & CERTIFICATIONS

NEMA WD-6, ANSI C-73, UL 1472, CSAC22.2 No. 184.1

DESCRIPTION

Slide Dimmer w/ Pre-set & LED - Single Pole

UL Listings: 60950, 60950-1, 60950-21



CHEETAH	COLOR
6110-C0A	ALMOND
6110-C0E	BLACK
6110-C0T	L ALMOND
6110-C0I	IVORY
6110-C0W	WHITE

DESCRIPTION

Slide Dimmer w/ Pre-set & LED - 3 Way

UL Listings: 60950, 60950-1, 60950-21



CHEETAH	COLOR
6120-C0A	ALMOND
6120-C0E	BLACK
6120-C0T	L ALMOND
6120-C0I	IVORY
6120-C0W	WHITE

DESCRIPTION

Slide Dimmer w/ Pre-set - Single Pole

UL Listings: 60950, 60950-1, 60950-21



CHEETAH	COLOR
6100-C0A	ALMOND
6100-C0E	BLACK
6100-C0T	L ALMOND
6100-C0I	IVORY
6100-C0W	WHITE

DESCRIPTION

Slide Dimmer - Single Pole

UL Listings: 60950, 60950-1, 60950-21

CHEETAH	COLOR
6090-C0A	ALMOND
6090-C0E	BLACK
6090-C0T	L ALMOND
6090-C0I	IVORY
6090-C0W	WHITE

Lighting Controls - Dimmers

ROTARY DIMMER - SINGLE POLE - 600W - 60HZ

Rated: 120V - 60 Hz Standard UL 1472 Standard CSA-C22.2 No. 184.1

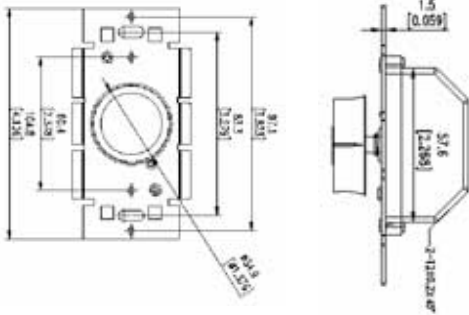

ELECTRICAL

Voltage:	120 Volt AC - 60 Hz
Load Type:	Incandescent
Load Rating:	600 Watts
Filtering:	Radio Frequency Interference Filtering
De-Rating:	Finned Aluminum Tabbed - 600W/500W/400W
Pre-Set:	On/Off
Construction:	Printed Solid-State Circuit Board

MECHANICAL

Wiring:	6" color-coded Leads Pre-Stripped - 16 gauge
Heat Sink:	Wide Mount Aluminum Fins

ENVIRONMENTAL

Flammability:	UL94 V2
Operating Temp:	Indoor Use Only

CHEETAH	COLOR
6060-C0A	ALMOND
6060-C0E	BLACK
6060-C0T	L ALMOND
6060-C0I	IVORY
6060-C0W	WHITE

Screwless Wallplates

SCREWLESS WALLPLATES

Standard UL 514D Standard CSA-C22.2 No.

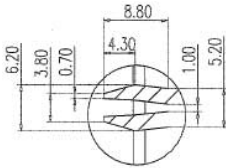
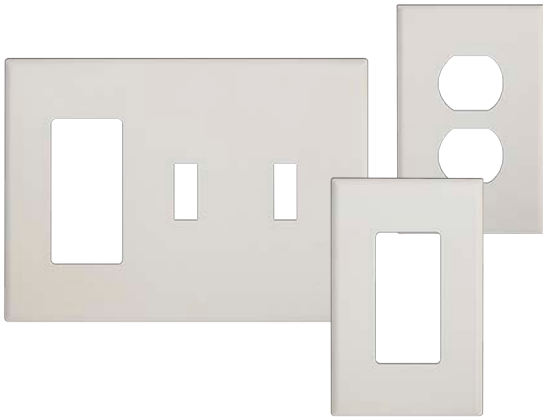

Patented Cheetah Screwless Wallplate "One Step" Snap System Design.

MECHANICAL

Material: Thermoplastic
 Finish: Matte Finish
 Colors: Almond, Black, Light Almond, Ivory, White
 Resilience: Unbreakable

ENVIRONMENTAL

Flammability: UL94 V2

STANDARDS & CERTIFICATIONS

NEMA, ANSI, UL 514D, CSAC22.2

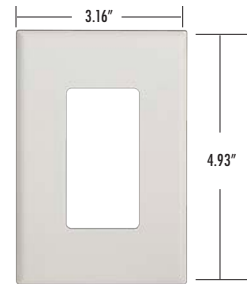

DESCRIPTION

1-Gang Toggle Wallplate

- * unbreakable plastic
- * screwless design

ITEM

COLOR

PJ1C-C0A	ALMOND
PJ1C-C0E	BLACK
PJ1C-C0T	L ALMOND
PJ1C-C0I	IVORY
PJ1C-C0W	WHITE

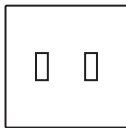

2-Gang Toggle Wallplate

- * unbreakable plastic
- * screwless design

PJ2C-C0A	ALMOND
PJ2C-C0E	BLACK
PJ2C-C0T	L ALMOND
PJ2C-C0I	IVORY
PJ2C-C0W	WHITE

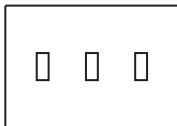

3-Gang Toggle Wallplate

- * unbreakable plastic
- * screwless design

PJ3C-C0A	ALMOND
PJ3C-C0E	BLACK
PJ3C-C0T	L ALMOND
PJ3C-C0I	IVORY
PJ3C-C0W	WHITE

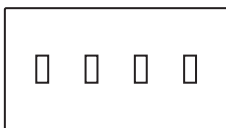

4-Gang Toggle Wallplate

- * unbreakable plastic
- * screwless design

PJ4C-C0A	ALMOND
PJ4C-C0E	BLACK
PJ4C-C0T	L ALMOND
PJ4C-C0I	IVORY
PJ4C-C0W	WHITE

Screwless Wallplates

DECORA® WALLPLATES



DESCRIPTION	ITEM #	COLOR
1-Gang Decora Wallplate	SJ26C-C0A	ALMOND
* unbreakable plastic	SJ26C-C0E	BLACK
* screwless design	SJ26C-C0T	L ALMOND
	SJ26C-C0I	IVORY
	SJ26C-C0W	WHITE

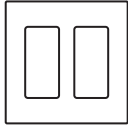

2-Gang Decora Wallplate	S262C-C0A	ALMOND
* unbreakable plastic	S262C-C0E	BLACK
* screwless design	S262C-C0T	L ALMOND
	S262C-C0I	IVORY
	S262C-C0W	WHITE

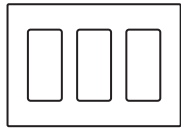

3-Gang Decora Wallplate	S263C-C0A	ALMOND
* unbreakable plastic	S263C-C0E	BLACK
* screwless design	S263C-C0T	L ALMOND
	S263C-C0I	IVORY
	S263C-C0W	WHITE

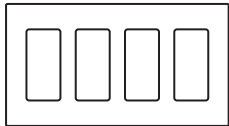

4-Gang Decora Wallplate	S264C-C0E	BLACK
* unbreakable plastic	S264C-C0T	L ALMOND
* screwless design	S264C-C0I	IVORY
	S264C-C0W	WHITE

DUPLEX AND BLANK WALLPLATES



DESCRIPTION	ITEM #	COLOR
1-Gang Duplex Wallplate	PJ8C-C0A	ALMOND
* unbreakable plastic	PJ8C-C0E	BLACK
* screwless design	PJ8C-C0T	L ALMOND
	PJ8C-C0I	IVORY
	PJ8C-C0W	WHITE

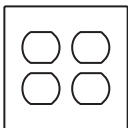

2-Gang Duplex Wallplate	PJ82C-C0A	ALMOND
* unbreakable plastic	PJ82C-C0E	BLACK
* screwless design	PJ82C-C0T	L ALMOND
	PJ82C-C0I	IVORY
	PJ82C-C0W	WHITE



1-Gang Blank Wallplate	PJ13C-C0A	ALMOND
* unbreakable plastic	PJ13C-C0E	BLACK
* screwless design	PJ13C-C0T	L ALMOND
* use with blank plate adapter	PJ13C-C0I	IVORY
	PJ13C-C0W	WHITE

Screwless Wallplates

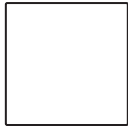

DESCRIPTION	ITEM #	COLOR
2-Gang Blank Wallplate	PJ23C-C0A	ALMOND
* unbreakable plastic	PJ23C-C0E	BLACK
* screwless design	PJ23C-C0T	L ALMOND
* use with blank plate adapter	PJ23C-C0I	IVORY
	PJ23C-C0W	WHITE

COMBO PLATES - 2-GANG WALLPLATES

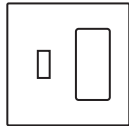

DESCRIPTION	ITEM #	COLOR
2-Gang Toggle/Decora Wallplate	P126C-C0A	ALMOND
* unbreakable plastic	P126C-C0E	BLACK
* screwless design	P126C-C0T	L ALMOND
	P126C-C0I	IVORY
	P126C-C0W	WHITE

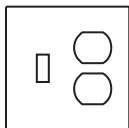

DESCRIPTION	ITEM #	COLOR
2-Gang Toggle/Duplex Wallplate	PJ18C-C0A	ALMOND
* unbreakable plastic	PJ18C-C0E	BLACK
* screwless design	PJ18C-C0T	L ALMOND
	PJ18C-C0I	IVORY
	PJ18C-C0W	WHITE

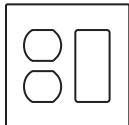

DESCRIPTION	ITEM #	COLOR
2-Gang Duplex/Decora Wallplate	P826C-C0A	ALMOND
* unbreakable plastic	P826C-C0E	BLACK
* screwless design	P826C-C0T	L ALMOND
	P826C-C0I	IVORY
	P826C-C0W	WHITE

COMBO PLATES - 3-GANG WALLPLATES

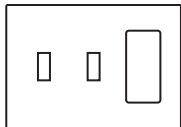

DESCRIPTION	ITEM #	COLOR
3-Gang Two Toggle/Decora Wallplate	P226C-C0A	ALMOND
* unbreakable plastic	P226C-C0E	BLACK
* screwless design	P226C-C0T	L ALMOND
	P226C-C0I	IVORY
	P226C-C0W	WHITE

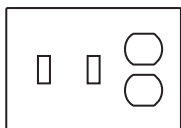

DESCRIPTION	ITEM #	COLOR
3-Gang Two Toggle/Duplex Wallplate	PJ21C-C0A	ALMOND
* unbreakable plastic	PJ21C-C0E	BLACK
* screwless design	PJ21C-C0T	L ALMOND
	PJ21C-C0I	IVORY
	PJ21C-C0W	WHITE

Screwless Wallplates

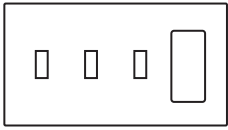

DESCRIPTION	ITEM#	COLOR
4-Gang Three Toggle/Decora Wallplate	2262C-C0A	ALMOND
* unbreakable plastic	2262C-C0E	BLACK
* screwless design	2262C-C0T	L ALMOND
	2262C-C0I	IVORY
	2262C-C0W	WHITE

ADVANCED ENGINEERING DESIGN



The patented Cheetah screwless wallplates have been designed to provide exceptional tight fit to Cheetah-enabled devices using eight (8) specially designed tabs. Each tab (top and bottom) provide resistance. As many as 6 tabs may break off and the wallplate still ensures a snug fit to the wall.

Cheetah wallplates are made from high strength thermo-plastic for unbreakable quality and stylish matte finish.

Each wallplate is specified to NEMA standards for Third Party compatibility.

2 tabs per Cheetah wallplate opening.

CHEETAH SPEED BOXES & ACCESSORIES



Wood Stud Box Installations

	DESCRIPTION	CATALOG #	
	1-Gang Box * 18 cu Inches	3001C	Wire Capacity: #14 - 9, #12 - 8, #10 - 7 Dimensions: 2.25" W x 3.75" H x 2.75" D
	1-Gang Big-A Box * 22.2 cu inches	3004C	Wire Capacity: #14 - 11, #12 - 10, #10 - 9 Dimensions: 2.25" W x 3.75" H x 3.5" D
	1-Gang Datacom Box * 18 cu inches	3005C	Wire Capacity: Low Voltage Wire Dimensions: 2.25" W x 3.75" H x 3.5" D
	1-Gang Adjustable Big-A * 22 cu inches	3023C	Wire Capacity: #14 - 11, #12 - 10, #10 - 9 Dimensions: 2.25" W x 3.75" H x 3.5" D
	2-Gang Box * 34 cu inches	3006C	Wire Capacity: #14 - 17, #12 - 15, #10 - 13, #6 - 6 Dimensions: 4.0" W x 3.75" H x 2.75" D
	2-Gang Big-A box - - DRYER/RANGE PORT * 40 cu inches	3007C	Wire Capacity: #14 - 20, #12 - 18, #10 - 16, #6 - 6 Dimensions: 4.0" W x 3.75" H x 3.5" D
	3-Gang Box * 44 cu inches	3008C	Wire Capacity: #14 - 22, #12 - 19, #10 - 17, #6 - 8 Dimensions: 5.75" W x 3.75" H x 2.75" D
	3-Gang Big-A box * 58 cu inches	3009C	Wire Capacity: #14 - 30, #12 - 28, #10 - 24, #6 - 12 Dimensions: 5.75" W x 3.75" H x 3.5" D
	4-Gang Box * 60 cu inches	3010C	Wire Capacity: #14 - 30, #12 - 28, #10 - 24, #6 - 14 Dimensions: 7.65" W x 3.75" H x 2.75" D
	4-Gang Big-A box * 76 cu inches	3011C	Wire Capacity: #14 - 40, #12 - 36, #10 - 32, #6 - 16 Dimensions: 7.65" W x 3.75" H x 3.5" D





Metal Stud Installations

	DESCRIPTION	CATALOG #	
	1-Gang Metal Stud Box w/ Self Drilling Metal Screws * 22 cu inches	3022C	Wire Capacity: #14 - 11, #12 - 10, #10 - 9 Dimensions: 2.25" W x 3.75" H x 3.5" D
	2-Gang Big-A box w/ Self Drilling Metal Screws * 40 cu inches	3026C	Wire Capacity: #14 - 20, #12 - 18, #10 - 16, #6 - 6 Dimensions: 4.0" W x 3.75" H x 3.5" D
	3-Gang Big-A box w/ Self Drilling Metal Screws * 58 cu inches	3027C	Wire Capacity: #14 - 30, #12 - 28, #10 - 24, #6 - 12 Dimensions: 5.75" W x 3.75" H x 3.5" D
	4-Gang Big-A box w/ Self Drilling Metal Screws * 76 cu inches	3028C	Wire Capacity: #14 - 40, #12 - 36, #10 - 32, #6 - 16 Dimensions: 7.65" W x 3.75" H x 3.5" D
	1-Gang Big-A Adjustable w/ Metal Screws * 22 cu inches	3025C	Wire Capacity: #14 - 11, #12 - 10, #10 - 9 Dimensions: 2.25" W x 3.75" H x 3.5" D
	1-Gang 1/2" Mud Ring * Fits 4"x4" Square box	3015C	 <p>Cheetah Metal Stud boxes come with metal self-drilling screws for side wall installations and greater stability.</p> 
	1-Gang 5/8" Mud Ring * Fits 4"x4" Square box	3016C	
	2-Gang 1/2" Mud Ring * Fits 4"x4" Square box	3017C	
	2-Gang 5/8" Mud Ring * Fits 4"x4" Square box	3018C	

Cheetah Mud Rings convert 4" square boxes into Cheetah speed Boxes..

QUESTIONS	ANSWERS
Can I use standard screw devices in Cheetah Speed Boxes?	Yes! Just insert two Cheetah Speed Anchors (Item #4000C) into the speed anchor slots of the box and it turns the Cheetah boxes into a normal outlet box.
How do I adjust a Cheetah device once it has been inserted into the Speed Anchor Slots (crooked stud installation)?	The Speed Anchors are pre-assembled and fastened to the Cheetah Device using standard 6/32 screws. Simply loosen fastened screws to vertically align device and re-tighten to compensate for crooked stud alignment.
How do you replace a Cheetah device once it has been installed?	Unscrew the Cheetah device as any other device. The Speed Anchors stay in the box. Using a screwdriver, punch the speed anchor through the slot (it will fall in back of the wall) and simply insert a new Cheetah device.
Why is a footplate included with all Multi-gang boxes	The footplate is adjustable to either 2"x 4" or 2" x 6" depths to butt up against the opposite wall - allow the multi-gang box to be more rigid for installation.
What type of screws come with the Metal Stud Boxes?	Cheetah Metal Stud Boxes come with 3.25" self drilling metal screws in the nail sleeves for easy side fastening to metal studs. All metal stud boxes also have a front flange for screws if needed.
What type boxes do the Mud Rings fasten to?	Cheetah 1 & 2-gang mud rings fasten to standard 4" square boxes (metal or plastic with diagonal screws)

Cut-In Box Installations

	DESCRIPTION	CATALOG #	
	1-Gang Shallow Cut-In Box * 14 cu inch	3000C	Wire Capacity: #14 - 6 , #12 - 5, #10 - 4 Dimensions: 2.5" W x 4.2" H x 2.5" D
	1-Gang Cut-In Box * 18 cu inches	3003C	Wire Capacity: #14 - 9, #12 - 8, #10 - 7 Dimensions: 2.5" W x 4.2" H x 3.35" D
	2-Gang Cut-In Box *34 cu inches	3022C	Wire Capacity: #14 - 17, #12 - 15, #10 - 13, #6 - 6 Dimensions: 4.0" W x 3.75" H x 2.75" D
	Low Voltage / Datacom Cut-In Bracket	4007C	





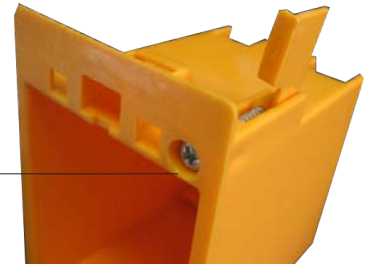

Low Voltage Cut-In Bracket is designed to "zip-tie" to sheet rock and then brake tabs off flush with wall.

Cheetah Cut-In Boxes are 2-Hour Fire Rated. Screws self-tighten pop-up flange to back of sheet rock.







Ceiling Installations

	DESCRIPTION	CATALOG #
	3" Ceiling Box	3012C
	Ceiling Speed Anchor - 52 MM * 100 lbs pull test rated	4001C
	Lamp Holder - Keyless	4008C
	Lamp Holder - Pull-Chain	4009C

DATAKOM SOLUTIONS

UL Standard 514C Nail-on Box, Mixed Voltage Dividers (multi-gang installations), Low Voltage Cut-In Bracket

	DESCRIPTION	CATALOG #	
	1-Gang Datacom Box * 18 cu inches	3005C	Wire Capacity: Low Voltage Wire Dimensions: 2.25" W x 3.75" H x 3.5" D
	Mixed Voltage Divider - Standard Box * Fits 2, 3 and 4 Standard gang boxes	4003C	
	Mix Voltage Divider - Big A Box * Fits 2, 3 and 4 Big-C0A gang boxes	4004C	
	Low Voltage / Datacom Cut-In Bracket * Fits directly to wall without stud	4007C	



Low Voltage / High Voltage Divider
Item# 4003C (Standard Box)
Item# 4004C (Big A Box)

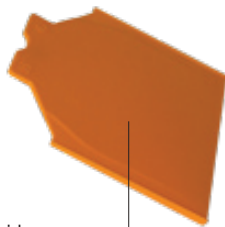

ACCESSORIES

Spark Rings, Speed Anchor Inserts, Blank Wallplate Adapter, Universal Adapter Ring



1 Gang Spark Ring 3019C
* Protective sleeve



Speed Anchor - 30 MM 4000C
* 50 lb pull test rated



Blank Wallplate Adapter 4005C
* Speed Anchor Attached/Included

Universal Adaptor 4006C
* Adapts most standard devices to receive cheetah screwless wallplates

Device Shims (Spacers) 4010C
* Shims to hold device flush to walls when drywall is cut too wide.



LAMP HOLDERS - KEYLESS 4008C
LAMP HOLDER - PULL CHAIN 4009C

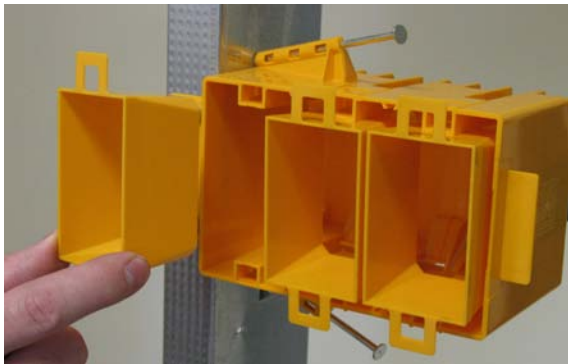

1 Gang Universal Spark Ring (Item #3019c) supports multi-gang installations. Spark Rings are used for extending a protective sleeve for devices where backsplash or wall to box exceeds 1/4". See local NEC requirements for further clarification of use.

Blank Wallplate Adapter is used to insert into a Cheetah speed box slots to fasten a screwless Blank wallplate.

The Blank Wallplate Adapter (Item#4005c) and Blank Wallplates (1-Gang Item#:PJ13C) (2-Gang Item#:PJ23C) are sold separately.



Blank Wallplate Adapter (Item#:4005C)



Blank Wallplate

WEATHERPROOF COVERS - "CHEETAH ENABLED" SOLUTIONS

UL Standard 514C Covers w/ UL 498 Standard Duplex or GFCI Receptacles (per assembled)

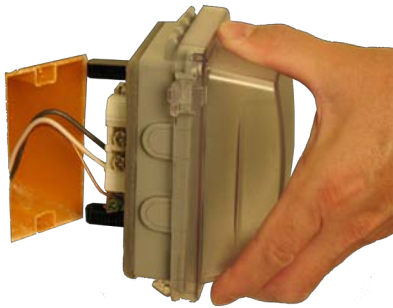

Bubble In Use Cover



Low Profile In Use Cover

DESCRIPTION	RECEPTACLE	CATALOG #
Clear Bubble Cover w/ 15 Amp Duplex	15A Duplex	86592-CCL
Clear Bubble Cover w/ 15 Amp GFCI	15A GFCI	86594-CGY
Low Profile Cover w/ 15 Amp Duplex	15A Duplex	86595-CGY
Low Profile Cover w/ 15 Amp GFCI	15A GFCI	86596-CGY

WEATHERPROOF COVERS

UL Standard 514C Covers w/ UL 498 Standard Duplex or GFCI Receptacles (per assembled)

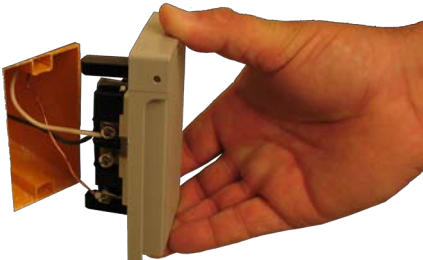

Horizontal Weatherproof Cover
w/ 15A Duplex



Vertical Weatherproof Cover
w/ 15A Duplex

DESCRIPTION	RECEPTACLE	CATALOG #
Horizontal Weatherproof Cover w/ 15 Amp Duplex - GRAY	15A Duplex	86597-CGY
Vertical Weatherproof Cover w/ 15 Amp Duplex - GRAY	15A Duplex	86598-CGY
Vertical Weatherproof Cover w/ 15 Amp GFCI - GRAY	15A GFCI	86599-CGY



2-Hour Wall Fire Rating Installation Guidelines

Intertek Testing Services NA Ltd., a Nationally Recognized Testing Laboratory (NRTL), has tested and certified the following Cheetah Nonmetallic Outlet Boxes (UL Standard 514C 3rd Edition) to ASTM E-814 (UL 1479), Standard Method for Fire Tests of Through-Penetration Fire Stops, to qualify for 1- and 2-hour fire rated wall and floor/ceiling installations, Listed to ASTM E119-03, Standard Methods of Fire Endurance Tests of Building Construction and Materials.

1-GANG CHEETAH OUTLET BOXES (18 cubic inch & 22 cubic inch)

Minimum horizontal box separation of 5" (inches), within same stud cavity. No minimum on vertical separation. Back-to-Back installation on common walls within 5" (inches), within same stud cavity. No additional fire resistive protection required.

2-GANG CHEETAH OUTLET BOXES (34 cubic inch & 40 cubic inch)

Minimum horizontal box separation of 12" (inches), within same stud cavity. No minimum on vertical separation. Back-to-Back installation on common walls within 12" (inches), within same stud cavity. Back-to-Back installation requires standard R12 fiberglass batt insulation in stud cavities.

3-GANG CHEETAH OUTLET BOXES (44 cubic inch & 60 cubic inch)

Minimum horizontal box separation of 16" (inches), within separate stud cavity. No minimum on vertical separation. Back-to-Back installation on common walls within 16" (inches), within separate stud cavity. Back-to-Back installation requires standard R12 fiberglass batt insulation in stud cavities.

4-GANG CHEETAH OUTLET BOXES (60 cubic inch & 80 cubic inch)

Minimum horizontal box separation of 16" (inches), within separate stud cavity. No minimum on vertical separation. Back-to-Back installation on common walls within 16" (inches), within separate stud cavity. Requires standard R12 fiberglass batt insulation in stud cavities.

1 & 2-GANG MUD RINGS (1/2" & 5/8")

For use on metal 4"x 4" Outlet boxes - minimal horizontal and vertical separation determined by metal box installation guidelines..

1-Hour Fire Floor/Ceiling Rating Installation Guidelines

1-GANG CHEETAH OUTLET BOXES (18 cubic inch & 22 cubic inch)

Floor/ceiling assembly was constructed with 2x10 floor joists, 5/8" plywood sub-floor and two layers of 1/2" Type X gypsum wallboard ceiling membrane according to ASTM E119-05, Fire Tests of Building Construction and Materials.

3" CEILING BOXES

Floor/ceiling assembly was constructed with 2x10 floor joists, 5/8" plywood sub-floor and two layers of 1/2" Type X gypsum wallboard ceiling membrane according to ASTM E119-05, Fire Tests of Building Construction and Materials.

Appendix A - NO Ground Screw on Cheetah Snap switches

Note: Cheetah USA Wide Plastic Yoke Snap Switches were recently approved/allowed under the 2011 NEC 404.9

The assumptions and premise of the NEC 404.9 stipulations are based upon the use of metal yoke devices. Metal yokes have been the norm for over 40 years (if not longer). All considerations for grounding the snap switches were in reference to the metal yoke and the possibility of using a metal wall plate attached to the metal yoke that could become energized. We fully recognize this critical NEC stipulation for metal yokes and use of metal wall plates with metal yokes.

With the introduction of our unique dielectric plastic yoke, we simply have changed the paradigm and assumptions of the present 404.9 code. As with all innovation in technology, innovation usually proceeds the current code stipulations and requires proper documentation to all those in authority to evaluate "equivalent safety compliance". Inspectors across the nation have recognized that our new innovation of using a plastic yoke for our snap switches changes the fundamental assumptions set forth by the 404.9 stipulations. We would ask that in evaluating the following considerations, that the entire assumptions and premise of the 404.9 code in relation to metal yoke devices must be re-evaluated because of our plastic yoke.

1. The Cheetah plastic dielectric strap cannot become energized. It acts similar to the properties of a plastic wire nut. The dielectric strap insulates the terminals and wires on the back of the device from becoming energized. Our UL laboratory (Intertek) conducted a test of where they placed 4500 volts directly to the plastic strap - no parts on the face of the plastic yoke and snap switch became energized or had any dielectric breakdown. Our dilemma when we developed the plastic yoke was why would you put a ground screw on plastic? A similar question was how do you ground a plastic wire nut? After complete UL 20 testing by our laboratory, the overarching question of why put a ground screw on plastic made us realize that indeed we had discovered a new paradigm to the NEC 404.9 stipulations and introduced a new innovation that changed the 40+ year use of metal yokes on devices.

2. One question often asked is, "what if someone violates your UL listed product and somehow fastened a metal wall plate to the plastic yoke"? Cheetah snap switches contain NO screw holes to fasten wall plates (metal or non-metallic). Only Cheetah screw-less non-metallic wallplates can be installed to Cheetah snap switches. Each Cheetah snap switch is clearly marked, "ONLY CHEETAH NON-METALLIC WALLPLATES CAN BE INSTALLED" (per UL listing). To violate the UL listing and the lack of a screw hole requires significant work effort on the part of the electrician. They would have to accurately mark the location of screw holes, drill a screw hole with the right drill bit size, and then use a self-tapping screw - normal wall plates screws are not self tapping to fasten the wall plate. While NO manufacturer can stop the illegal installation of their devices, Cheetah has done everything possible to ensure proper installation. It would require the electrician to spend considerable time and effort (which they do not want to do) to violate our markings to improperly install a metal wall plate to Cheetah switches contrary to our listings. Again, even if an installation violates our listed product by somehow fastening a metal wall-plate, the 4500 volt dielectric test conducted by our UL laboratory proves that even with a metal plate fastened to the plastic yoke, the plastic yoke properly insulates and protects the metal wallplate from becoming energized.

3. Another question asked is "what about the metal screws holding the speed anchors to the plastic yoke"? With a sample of our device and cheetah speed outlet box, you will notice that the metal screws holding the speed anchors to the device are not exposed inside the cheetah box. They are fully enclosed within the speed anchor "channel" of the outlet box they are inserted in. There is no metal exposed inside the outlet box.

4. Another question, "since the Cheetah snap switch does not require a ground wire, what about the ground wire in the outlet box?" The provisions of NEC 250.148 (D) require a ground wire be pulled to every outlet box in the house - this should be fully complied with. Because our snap switch does not require a grounding screw (how do you ground plastic?), it does not mean that electricians should eliminate or terminate the ground wire from the electrical box as stipulated by NEC code. Thus some jurisdictions have specifically stated that Cheetah snap switches are approved and further clarified that all provisions of NEC 250.148 (D) should be met. We assume with all other manufacturers that standard NEC wire stipulations are enforced.

5. All Cheetah snap switches have passed the UL 20 standards for general purpose snap switches. The fact that any device or product could be installed contrary to their listing is self evident. In speaking with numerous inspectors across the nation, many recognize the ground wire is not necessary for switch operation and is only used because of the metal yoke/metal wall plate installation condition. Cheetah Snap switches have been properly evaluated to the highest UL standards for safety. Because of the innovation of our plastic yoke, they agree that the stipulations of NEC 404.9 do not apply and that equivalent safety compliance is met.

6. Cheetah has done all we can do to comply with requests for adequate documentation and valid test reports that demonstrate our new paradigm in electrical products. We recognize that we are the first to introduce innovation in a market where metal yokes have been the standard for many years. We feel that plastic yokes will become the wave of the future with superior safety features over metal yokes. The fact that we have introduced a new paradigm to the existing 404.9 assumptions (metal yokes and metal wall plates), should at least allow consideration for our new innovation and not burden us with the assumptions of the old paradigm. Thankfully the NEC does allow for innovation so that "specific requirements in the code" may be waived or "alternative methods" be employed where "equivalent objectives can be achieved by establishing and maintaining effective safety" (NEC 90.4). Our unique product meets and in many ways exceeds the equivalent safety objectives set forth. Consideration must be made in light of the fact that our plastic dielectric straps completely change the paradigm under which 404.9 metal yoke / metal wall plate assumptions were made.

7. Cheetah USA has complied with all respective standards set forth by UL. We rely heavily upon Nationally Recognized Testing Laboratories to validate and ensure strict compliance. The UL 20 certification and subsequent safety reports were performed by our NRTL laboratory (Intertek /SEMKO issues the ETL listing mark). OSHA recognizes multiple NRTL laboratories for UL certification (see <http://www.osha.gov/dts/otpca/nrtl/index.html>) We presently use both Underwriting Laboratories and Intertek/SEMKO for our testing laboratories.

UL and ETL Certifications

All Cheetah products have been tested using the most stringent testing standards following the UL specification through OSHA-recognized testing laboratories. Using Nationally Recognized Testing Laboratories (NRTL), the Occupational Safety and Health Administration (OSHA) and American National Standards Institute (ANSI) ensures that all products meet and pass minimum requirements for safety.

Cheetah USA has chosen to use two National Recognized Testing Laboratory (NRTL) marks that support the UL specifications. Some Cheetah USA products have been tested, certified, and listed with the UL mark, while others have been tested, certified, and listed with the ETL mark. The important fact is that both testing laboratories support and enforce the same UL specification and meet all requirements of the OSHA standards. Both testing laboratories perform periodic inspections at manufacturing facilities to ensure compliance and quality. The UL specification is well defined in the industry and all Cheetah products are 100% compliant with the UL specification.

DIFFERENCE BETWEEN UL SPECIFICATION –VS- UL LISTED MARK

The UL specification is independent of testing laboratory or vendor. Consumers should not be confused with the UL specification and the UL Listed Mark. All Nationally Recognized Testing Laboratories (NRTL) use the UL specification in their certification and listing procedures. Each testing laboratory offers differing levels of customer services offering to differentiate and compete as testing laboratories, but each must be 100% compliant with the specifications outlined by OSHA and ANSI.

UL –VS- ETL LISTING MARKS



As indicated above, there are a number of Nationally Recognized Testing Laboratories (NRTL) that support the UL specifications. Each testing organization must be 100% compliant with all regulatory guidelines and specifications of the UL specification. Marks are listed by the respective Laboratory who has performed the compliance tests. Regardless of the UL listed mark or the ETL listed mark, the same UL specification and requirements have been met. Each laboratory has been approved, monitored, and certified through the Occupational Safety and Health Administration (OSHA). The Marks represent the company who performed the UL specification testing.

IS ANY MARK BETTER THAN THE OTHER?

No. The UL specification is the same. While each laboratory has many key differentiating customer service offerings and features, the end result to the consumer is that both UL listed marks and ETL listed marks, in relation to the UL specification, are identical. Each laboratory must meet the safety standards developed by the American National Standards Institute (ANSI). Many multi-national companies such as AT&T, Dell, Ericsson, General Electric, Panasonic, Philips, etc. use the ETL listed mark. Currently over 20,000 products have been tested by ETL SEMKO, a National Recognized Testing Laboratory (NRTL). Many national retailers, such as; JC Penney, Sears, Target, and others are also using the ETL listed mark.

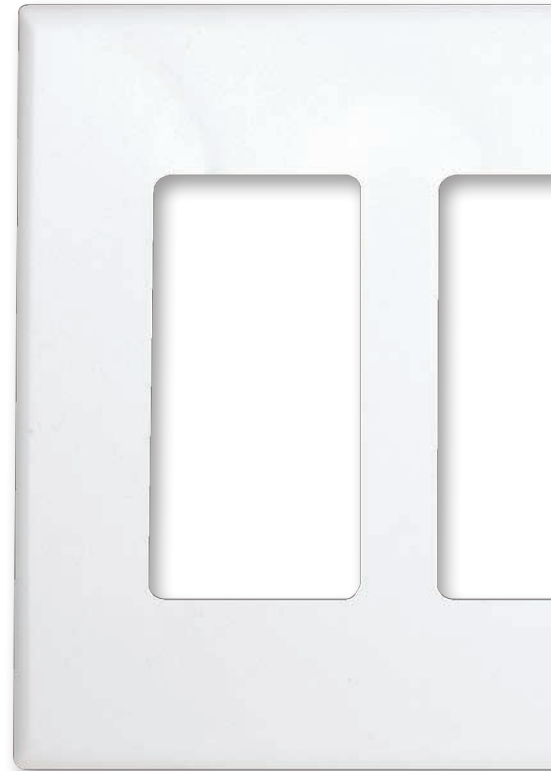

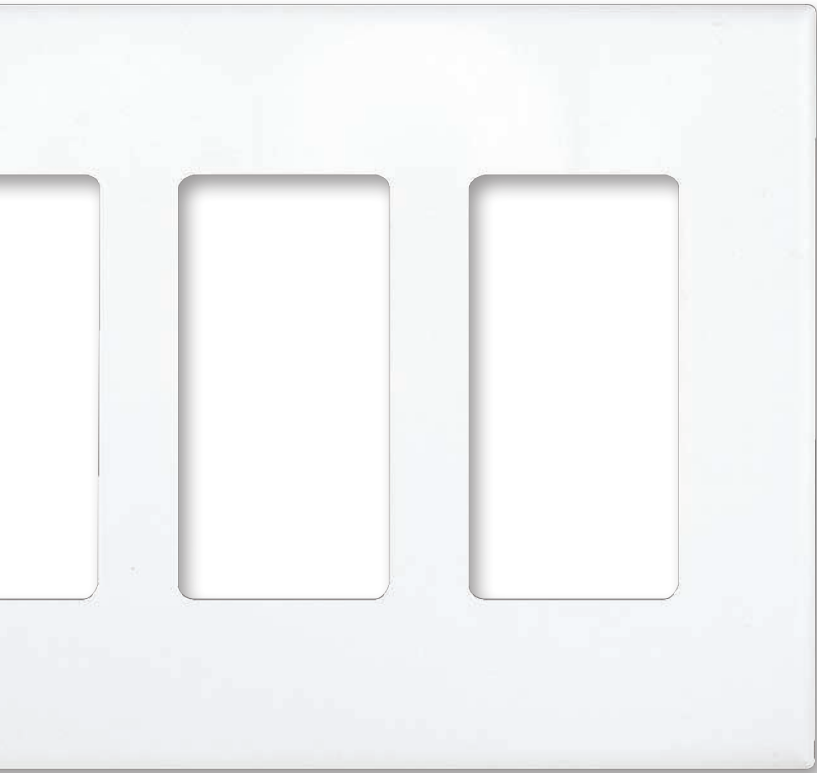

LEVITON®



Leviton Manufacturing Co., Inc.
201 North Service Road, Melville, NY 11747-3138
Telephone: 1-800-323-8920 • FAX: 1-800-832-9538
Tech Line (8:30AM-7:30PM E.S.T. Monday-Friday): 1-800-824-3005

Leviton Manufacturing of Canada, Ltd.
165 Hymus Boulevard, Pointe Claire, Quebec H9R 1E9
Telephone: 1-800-469-7890 • FAX: 1-800-563-1853

Leviton S. de R.L. de C.V.
Lago Tana 43, Mexico DF, Mexico CP 11290
Tel. (+52) 55-5082-1040 • Fax (+52) 55-5386-1797
www.leviton.com.mx

Visit our Website at www.leviton.com
www.cheetahspeed.com

© 2009 Leviton Manufacturing Co., Inc. All rights reserved. Subject to change without notice.