

PART NUMBER	SIZE	"R"	"O"	"H"	"S" MIN	"B" MIN	"L"
5133808	2"	60"	17 5/8"	34"	2"	N/A	47 1/8"
5134006	3"	60"	17 5/8"	34"	3 1/8"	N/A	47 1/8"
5133946	4"	60"	17 5/8"	34"	3 3/8"	N/A	47 1/8"
5133947	5"	60"	17 5/8"	34"	3 5/8"	N/A	47 1/8"
5133806	6"	60"	17 5/8"	34"	3 3/4"	N/A	47 1/8"

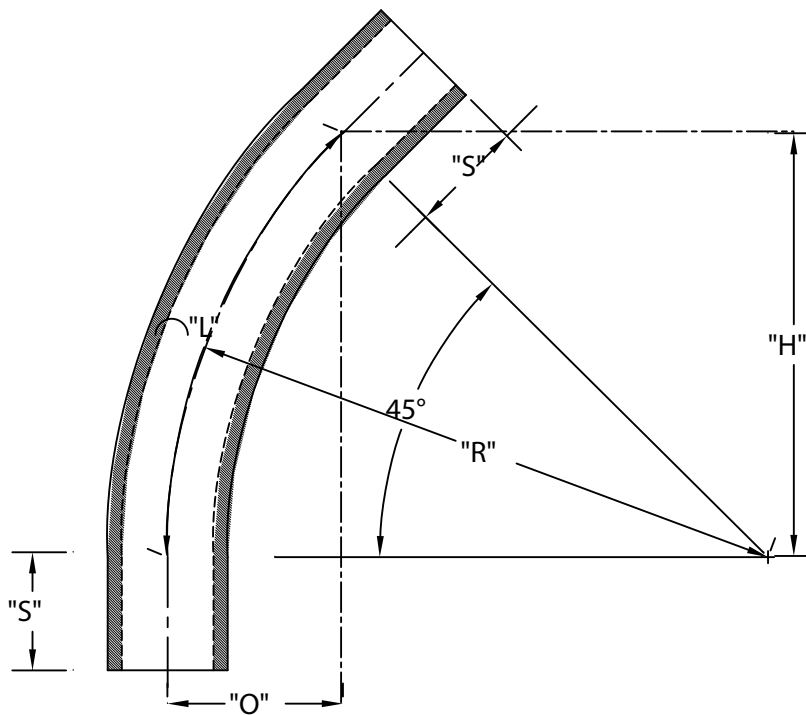

ETL LISTED
 CONFORMS TO UL651
 ETL CONTROL #3107144
 CONFORMS TO NEMA TC3
 SEE NEC ARTICLE 352 FOR USE
 MATERIAL IS RIGID PVC
 BEND TOLERANCE IS $\pm 2^\circ$



CANTEX
 INC.
 Fort Worth, TEXAS

45° Elbows Plain End
 Schedule 40 60" Radius Elbows

Drawn By: CD Branch

Date: 10/15/07

Ref.