



CADWELD® MULTI

CADWELD MULTI replaces over 35 separate molds with a single, universal mold crucible capable of performing a wide range of mold types. CADWELD MULTI performs conductor to ground rod weld types.

Features

- Versatile mold offers variety of connections for grounding applications
- Compact compression structure enables easy alignment of conductors
- Easy to use system completes the weld in seconds
- Easy to follow instruction guide
- Lightweight kit for easy transportation
- Meets standards requirements



Applications

Multiple grounding connection capabilities, including:

- Copper cable/solid to copper cable/solid
- Copper cable/solid/tape to rebar
- Copper cable/solid to copper or steel tape/lug
- Copper tape to copper tape
- Galvanized steel tape to galvanized steel tape
- Conductor to ground rod

More Information

How It Works

CADWELD MULTI uses a combination of a generic mold block and a range of disposable gaskets (batting). The gaskets are compressed around the conductors to allow numerous different welded connections to be produced - without the need to change the mold block for each connection type.

CADWELD MULTI Connection Capabilities

Note: the tables below use the following symbols to denote the number of batting (gaskets) layers required for each connection.



Requires 2 batting layers for weld



















Requires 3 batting layers for weld





NOTES:

- For connections using a 3/4" ground rod, it is necessary to use #115 / 115PLUSF20 welding material (sold separately).
- For all other connection types, use #90 or 90PLUSF20.
- For connections using galvanized material, remove galvanizing before welding, for a better connection.

Copper Cable/Solid to Copper Cable/Solid

Copper concentric conductor sizes up to 50 mm ² (9.3 mm dia.) or 1/0 AWG (0.37" dia.)				
 SS	 SC	 PA	 TA	 XA
 GG	 GJ	 PP	 PK	 GE
 PG	 GF	 GW	 XB	
Copper concentric conductor sizes up to 25mm ² (6.6 mm dia.) or #3 AWG (0.26" dia.)				
 TD	 TE	 TF		





Copper Cable/Solid Strip to Rebar

Copper concentric conductor sizes up to 50mm ² (9.3 mm dia.) or 1/0 AWG (0.37" dia.) Copper or steel strip sizes up to 30 x 3,5 mm (1.2" x 0.14") Rebar sizes up to 10 mm (#3)				
 RG	 RH	 RK	 NEW	 RD

Copper Strip to Copper Strip

BB and CG: Copper strip sizes up to 30 x 3,5 mm (1.2" x 0.14") BG and EB: Copper strip sizes up to 30 x 3,0 mm (1.2" x 0.12")			
 BB	 CG	 BG	 EB

Copper Cable/Solid to Copper or Steel Strip/Lug

Copper concentric conductor sizes up to 50mm ² (9.3 mm dia.) or 1/0 AWG (0.37" dia.) Copper or steel lug / strip sizes up to 30 x 3,5 mm (1.2" x 0.14")				
 HA	 HC	 GL	 LA	 LJ

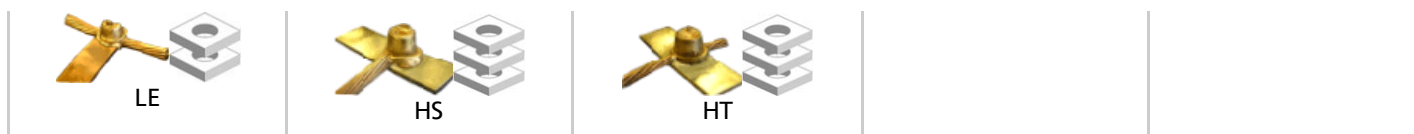

Galvanized Steel Strip to Galvanized Steel Strip

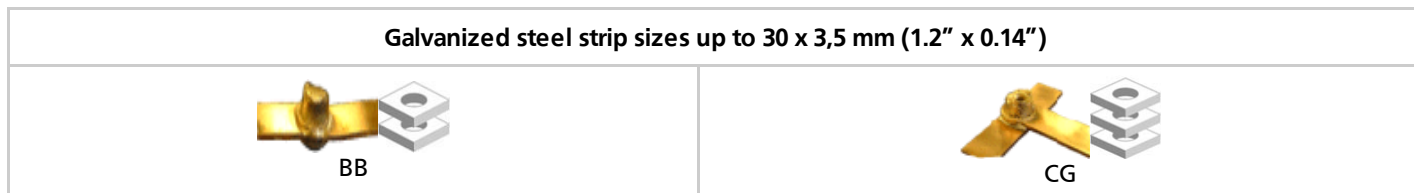

Ground Rod Connections

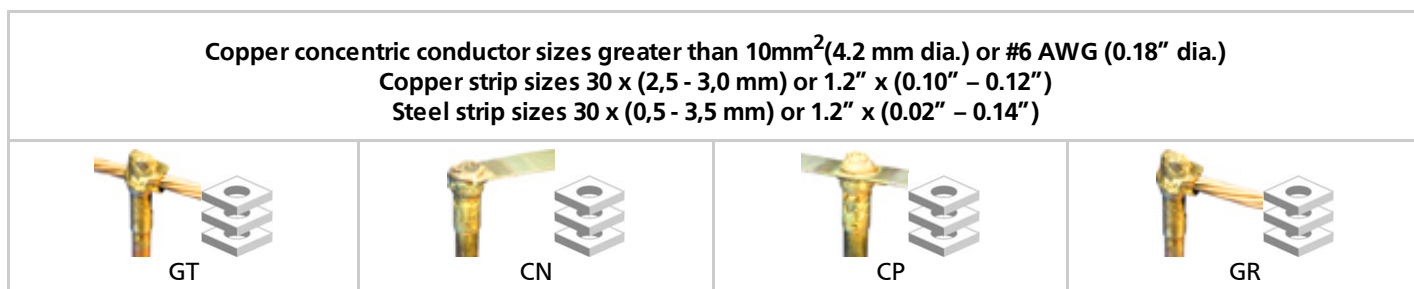
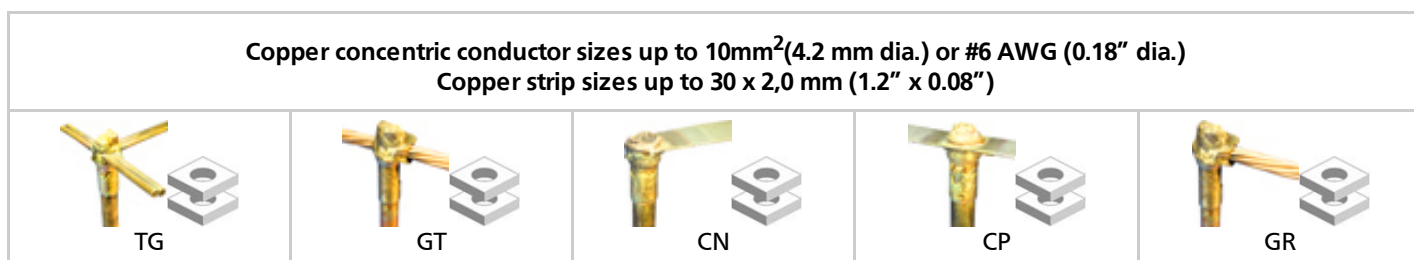

Ordering Information

Part No.	Article No.	Description	Pack Size	Weight (kg)
KITCDMV01	167782	CADWELD MULTI Kit	1	25.000
<i>The CADWELD MULTI kit (KITCDMV01) contains the following list of items:</i>				
FMCDMV01	120883	Handle Clamp	1	1.800
CDMV01H	240399	Mold for H welds	1	1.200
CDMV0112	240398	Mold for welds on 1/2 rods	1	1.200
CDMV0158	240397	Mold for welds on 5/8 rods	1	1.200
CDMV0134	240396	Mold for welds on 3/4 rods*	1	1.200
SCDM01	120886	Set of 33 batting/gaskets	2	0.200

B399P	162070	SKK1 clamp	1	0.500
TSCSTP	197295	Toolset	1	2.000
B136B	182030	Slag Removal Spade	1	0.144
		Language free instruction sheet	1	

The following items can be used with the CADWELD MULTI Kit (KITCDMV01). They are sold separately.

Ordering Information

Part No.	Article No.	Description	Pack Size	Weight (kg)
T320	165000	Flint Ignitor T320	1	0.090
90	163040	CADWELD Traditional welding material	10	0.090
115	163050	CADWELD Traditional welding material	10	0.115
PLUSCU	165738	Control Unit	1	1.088
PLUS#90F20	165705	CADWELD PLUS welding material	10	0.158
PLUS#115F20	165706	CADWELD PLUS welding material	10	0.185
CDMV0138	240405	Mold for welds on 3/8" rods	1	0.513

Due to ERICO's continuous product improvement policy, products shown in this catalog are subject to change without notice. For further information, contact ERICO.



0:00 /

WARNING

ERICO products shall be installed and used only as indicated in ERICO's product instruction sheets and training materials. Instruction sheets are available at www.erico.com and from your ERICO customer service representative. Improper installation, misuse, misapplication or other failure to completely follow ERICO's instructions and warnings may cause product malfunction, property damage, serious bodily injury and death.

WARRANTY

ERICO products are warranted to be free from defects in material and workmanship at the time of shipment. NO OTHER WARRANTY, WHETHER EXPRESS OR IMPLIED (INCLUDING ANY WARRANTY OF MERCHANTABILITY OR FITNESS FOR A PARTICULAR PURPOSE), SHALL EXIST IN CONNECTION WITH THE SALE OR USE OF ANY ERICO PRODUCTS. Claims for errors,

shortages, defects or nonconformities ascertainable upon inspection must be made in writing within 5 days after Buyer's receipt of products. All other claims must be made in writing to ERICO within 6 months from the date of shipment or transport. Products claimed to be nonconforming or defective must, upon ERICO's prior written approval in accordance with its standard terms and procedures governing returns, promptly be returned to ERICO for inspection. Claims not made as provided above and within the applicable time period will be barred. ERICO shall in no event be responsible if the products have not been stored or used in accordance with its specifications and recommended procedures. ERICO will, at its option, either repair or replace nonconforming or defective products for which it is responsible or return the purchase price to the Buyer. THE FOREGOING STATES BUYER'S EXCLUSIVE REMEDY FOR ANY BREACH OF ERICO WARRANTY AND FOR ANY CLAIM, WHETHER SOUNDING IN CONTRACT, TORT OR NEGLIGENCE, FOR LOSS OR INJURY CAUSED BY THE SALE OR USE OF ANY PRODUCT.

LIMITATION OF LIABILITY

ERICO excludes all liability except such liability that is directly attributable to the willful or gross negligence of ERICO's employees. Should ERICO be held liable its liability shall in no event exceed the total purchase price under the contract. ERICO SHALL IN NO EVENT BE RESPONSIBLE FOR ANY LOSS OF BUSINESS OR PROFITS, DOWNTIME OR DELAY, LABOR, REPAIR OR MATERIAL COSTS OR ANY SIMILAR OR DISSIMILAR CONSEQUENTIAL LOSS OR DAMAGE INCURRED BY BUYER.

Due to a policy of continued product development, specifications are subject to change without notice.

Copyright © 2014 ERICO International Corporation.

CADDY, CADWELD, CRITEC, ERICO, ERIFLEX, ERITECH, and LENTON are registered trademarks of ERICO International Corporation.

