

**T&B® Fittings**

# **T&B® Cord & Cable Fittings**

**In this section...**

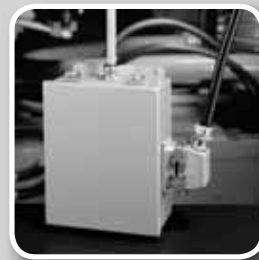

## **T&B® Cord & Cable Fittings**

|  |             |
|--|-------------|
| STAR TECK® Teck Cable Fittings.....                  | E-122-E-130 |
| Spin-On® Series Fittings and Accessories .....       | E-131-E-132 |
| Metallic Liquidtight Cord and Cable Connectors ..... | E-133-E-142 |
| Non-Metallic Liquidtight Cord Connectors .....       | E-143-E-146 |
| Service Entrance Cable Fittings.....                 | E-147-E-151 |
| MC and AC Cable Fittings.....                        | E-152-E-158 |
| Tray Cable Fittings.....                             | E-159       |
| Non-Metallic Sheathed Cable Fittings.....            | E-160-E-164 |

**Thomas & Betts**

[www.tnb.com](http://www.tnb.com)

## STAR TECK® Teck Cable Fittings

### STAR TECK® STE/STEX Series Cable Fittings

The STAR TECK® STE cable fitting series is designed for optimum integrity in ordinary applications. The STEX series is specially designed for classified hazardous areas. Both are designed to stand up to the harshest and most corrosive environment.

#### Application

- Provides means for passing jacketed metal clad cables through a bulkhead or enclosure in industrial and hazardous areas. (These fittings are suitable for hazardous areas when used with T&B sealing compound)
- Forms a mechanical grip and water- and/or oil-resistant termination
- Provides grounding continuity of cable armor

#### Features

- Powergrip grounding ring
- Removable armor-stop for greater cable ranges
- Built-in sealing device
- Elastomeric collar ring/ bushing for greater cable ranges
- Built-in jacket stripping gauge on gland nut
- Gland nut can be tightened with hammer and screwdriver

#### Range

- STAR TECK EXTREME® fittings are designed to accommodate a broad range of cables. Each hub range overlaps the adjacent hub range, thereby minimizing the possibility of mismatched cables and fittings in the field. They are available in hub sizes from ½" to 4" and will handle outer jacket diameters from .525" to 4.340"

#### Materials

Aluminum is standard material  
 Add suffix "S" for steel with zinc plating  
 Add suffix "PVC" for corrosion-resistant PVC coating  
 Add suffix "SS" for stainless steel material

#### Cable Type

JMC, MC-HL, Teck

#### Environment Classification

STE\* Series  
 –Ordinary Location  
 –Class I, Division 2†  
 –NEMA 4, 4X (stainless steel), 6P  
 –STE050 – STE200  
   NEMA 6P  
 –STE250 – 400  
   NEMA 4  
 –STE050 – 400  
   NEMA 4X (stainless steel)  
 STEX\*\* Series  
 –Class I, Division 1, Groups A, B, C, D  
 –Class II, Division 1, Groups E, F, G  
 –Class III  
 –NEMA 4, 4X (stainless steel), 6P

UL Listed for Direct Burial when made from stainless steel material  
 Suitable for use in wet locations and concrete tight (steel) applications per UL 514B  
 UL File No. E82038/E38947  
 CSA File No. LR638/LR23086

\* These fittings are suitable for Class I hazardous locations when used in combination with a certified Class I hazardous location sealing fitting.

\*\* Meets NEC® Class I Division 2/Zone 2 and Class II Division 2/Zone 22 requirements when installed as per Articles 501.10/505.15 and 502.10/506.15

\*\*\* May be used in hazardous areas with approved MC-HL or Teck cable (or equal) when installed in accordance with NEC®/CEC requirements.

Not applicable to all STEX series.

NEC and National Electrical Code are registered trademarks of the National Fire Protection Association, Inc.



**Greater Cable Range + Fewer Part Numbers = Less Inventory!**

## STAR TECK® Teck Cable Fittings



STE Series Ordinary



STEX Series Hazardous Locations



### STAR TECK EXTREME® Jacketed Metal-Clad Cable Fittings

| CAT. NO.                   | HUB SIZE NPT | STRIP LENGTH (IN.) | GLAND TORQUE (IN.-LB.) | CABLE RANGE OVER JACKET (IN.) |       | CABLE RANGE OVER ARMOR (IN.) |       | DIMENSIONS (IN.)                |                                  |           | SEALING COMPOUND REQUIRED |                |                     |
|----------------------------|--------------|--------------------|------------------------|-------------------------------|-------|------------------------------|-------|---------------------------------|----------------------------------|-----------|---------------------------|----------------|---------------------|
|                            |              |                    |                        | MIN.                          | MAX.  | MIN.                         | MAX.  | A1: THROAT DIA. MIN. W/END STOP | A2: THROAT DIA. MIN. WO/END STOP | B OVERALL | C MAX. O.D.               | SC65 PUTTY (G) | SC4-KIT LIQUID (CC) |
|                            |              |                    |                        |                               |       |                              |       |                                 |                                  |           |                           |                |                     |
| <b>Ordinary Locations</b>  |              |                    |                        |                               |       |                              |       |                                 |                                  |           |                           |                |                     |
| ST050-462#                 | 1/2          | 1 1/4              | 300                    | .525                          | .650  | .415                         | .570  | N/A*                            | .395                             | 2.020     | 1.224                     | —              | —                   |
| STE050DATA**#              | 1/2          | 7/8                | 300                    | .592                          | .693  | .502                         | .603  | .375                            | .515                             | 2.100     | 1.360                     | —              | —                   |
| STE050*                    | 1/2          | 1 1/4              | 300                    | .600                          | .985  | .520                         | .895  | .505                            | .612                             | 2.650     | 1.630                     | —              | —                   |
| STE075*                    | 3/4          | 1 1/4              | 600                    | .860                          | 1.205 | .780                         | 1.125 | .655                            | .816                             | 2.900     | 2.080                     | —              | —                   |
| STE100*                    | 1            | 1 1/4              | 700                    | .950                          | 1.375 | .870                         | 1.295 | .785                            | 1.044                            | 3.020     | 2.300                     | —              | —                   |
| STE125*                    | 1 1/4        | 1 1/4              | 1,000                  | 1.150                         | 1.625 | .990                         | 1.465 | .970                            | 1.250                            | 4.010     | 2.820                     | —              | —                   |
| STE150*                    | 1 1/2        | 1 3/4              | 1,200                  | 1.440                         | 1.965 | 1.280                        | 1.805 | 1.260                           | 1.562                            | 4.290     | 3.250                     | —              | —                   |
| STE200*                    | 2            | 1 3/4              | 1,600                  | 1.825                         | 2.375 | 1.665                        | 2.215 | 1.645                           | 1.995                            | 4.120     | 3.600                     | —              | —                   |
| STE250                     | 2 1/2        | 2 1/2              | 1,600                  | 2.265                         | 2.840 | 2.105                        | 2.680 | 2.075                           | 2.424                            | 5.320     | 4.750                     | —              | —                   |
| STE300                     | 3            | 2 1/2              | 1,600                  | 2.670                         | 3.270 | 2.545                        | 3.145 | 2.531                           | 2.890                            | 5.400     | 5.400                     | —              | —                   |
| STE350                     | 3 1/2        | 2 1/2              | 1,600                  | 3.220                         | 3.870 | 3.090                        | 3.640 | 3.065                           | 3.460                            | 5.360     | 5.900                     | —              | —                   |
| STE400                     | 4            | 2 1/2              | 1,600                  | 3.665                         | 4.340 | 3.550                        | 4.225 | 3.525                           | 3.941                            | 5.415     | 6.400                     | —              | —                   |
| <b>Hazardous Locations</b> |              |                    |                        |                               |       |                              |       |                                 |                                  |           |                           |                |                     |
| STX050-462*                | 1/2          | 1 1/4              | 300                    | .525                          | .650  | .415                         | .570  | N/A*                            | .395                             | 2.500     | 1.630                     | 7              | 4                   |
| STX050-464*                | 1/2          | 1 1/4              | 300                    | .600                          | .760  | .490                         | .680  | N/A*                            | .485                             | 2.530     | 1.630                     | 7              | 4                   |
| STEX075*                   | 3/4          | 1 1/4              | 600                    | .600                          | .985  | .520                         | .895  | .504                            | .678                             | 3.400     | 1.820                     | 14             | 7                   |
| STEX100*                   | 1            | 1 1/4              | 700                    | .860                          | 1.205 | .780                         | 1.125 | .650                            | .833                             | 3.580     | 2.300                     | 30             | 16                  |
| STEX125*                   | 1 1/4        | 1 1/4              | 1,000                  | .950                          | 1.375 | .870                         | 1.295 | .834                            | 1.065                            | 3.920     | 2.510                     | 45             | 22                  |
| STEX150*                   | 1 1/2        | 1 3/4              | 1,200                  | 1.150                         | 1.625 | .990                         | 1.465 | .958                            | 1.273                            | 5.020     | 3.260                     | 80             | 43                  |
| STEX200*                   | 2            | 1 3/4              | 1,600                  | 1.440                         | 1.965 | 1.280                        | 1.805 | 1.250                           | 1.560                            | 5.120     | 3.620                     | 125            | 66                  |
| STEX250                    | 2 1/2        | 2 1/2              | 1,600                  | 1.825                         | 2.375 | 1.665                        | 2.215 | 1.640                           | 1.995                            | 5.170     | 4.580                     | 341            | 164                 |
| STEX300                    | 3            | 2 1/2              | 1,600                  | 2.265                         | 2.840 | 2.105                        | 2.680 | 2.075                           | 2.461                            | 6.610     | 5.100                     | 497            | 239                 |
| STEX350                    | 3 1/2        | 2 1/2              | 1,600                  | 2.670                         | 3.270 | 2.545                        | 3.145 | 2.531                           | 2.864                            | 7.380     | 5.790                     | 965            | 464                 |
| STEX400                    | 4            | 2 1/2              | 1,600                  | 3.220                         | 3.870 | 3.090                        | 3.640 | 3.055                           | 3.461                            | 7.650     | 6.190                     | 1323           | 636                 |
| STX400-484#                | 4            | —                  | 1,600                  | 3.810                         | 4.030 | 3.680                        | 3.870 | —                               | —                                | —         | —                         | 1645           | 791                 |
| STX400-485#                | 4            | —                  | 1,600                  | 3.965                         | 4.185 | 3.835                        | 4.025 | —                               | —                                | —         | —                         | 1645           | 791                 |

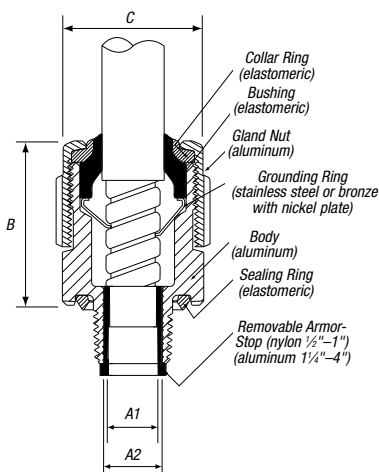

To specify other material, add the appropriate suffix to the catalog number.

| DESIRED MATERIAL                         | SUFFIX | EXAMPLE      |
|--|--------|--------------|
| Aluminum fitting with grounding lock nut | GRL    | STE-050GRL   |
| Steel with zinc plate                    | S      | STE-050S     |
| Stainless steel                          | SS     | STX050-462SS |
| Aluminum with PVC coating                | PVC    | STE-050PVC   |
| Steel with PVC coating                   | S-PVC  | STE-050S-PVC |

\* These products are UL Listed Watertight NEMA Type 6P

\*\* UL tested for data cables

# Does not have a removable armor stop.

### Sealing Compounds — Used for Hazardous Locations

| CAT. NO. | DESCRIPTION   | VOLUME              |
|----------|---|---------------------|
| SC65     | Putty-Type Sealing Compound   | 60 grams            |
| SC4-KIT  | Liquid-Type Sealing Compound for Use in High Wire Density Applications (five or more wires) | 2.8 fl. oz. (66 cc) |

## STAR TECK® Teck Cable Fittings

### STAR TECK® Jacketed Metal-Clad Cable Fittings

Overlapping range of sizes. STAR TECK® jacketed metal-clad cable fittings are designed to accommodate a broad range of cables, thereby minimizing the possibility of mismatched cables and fittings in the field.



#### Application

- Provide means for passing armored, metal-clad, jacketed cables through a bulkhead or enclosure in hazardous areas (these fittings are suitable for hazardous areas when used with T&B sealing compound)
- Form a mechanical grip and water- and/or oil-resistant termination

- Provide grounding continuity of cable armor

#### Cable Type

- JMC, MC-HL, Teck

#### Features

##### Easy Installation

- Exclusive power-grip. Provides a grip that's high up on the cable — not on the first convolvement — so strip length and cutting of cable are not as critical

##### Dependable Service

- Stainless steel retaining ring. Withstands corrosive environments. Non-magnetic

##### Dependable Grounding

- Power-Grip grounding ring is non-magnetic stainless steel. Provides 360° long-term dependable grounding. It makes immediate contact with the cable

##### Watertight

- Tapered bushing. Cone shaped to provide a secure, tight fit while eliminating cupping or water in vertical installations

#### Easy to Install in Tight Spaces

- Low-profile gland nut fits tight spaces. Has grooves for screwdriver installation, and flats for a wrench. Durable and reusable with funnel entry for easy cable insertion

#### Materials

Aluminum is standard material

Add suffix "S" for steel with zinc plating

Add suffix "PVC" for corrosion-resistant PVC coating

Add suffix "SS" for stainless steel Grade 316 material (½"–2" sizes)

#### Environment Classification

Meets NEC® Class I Division 2/Zone 2 and Class II Division 2/Zone 22 requirements when installed as per Articles 501.10/505.15 and 502.10/506.15

NEMA 4

Suitable for use in wet locations and concrete tight (steel) applications per UL 514B

UL File No. E82038/E38947

CSA File No. LR638/LR23086

#### Range

Available in hub sizes from ½" to 4", and will handle outer jacket diameters from .525" to 4.340"

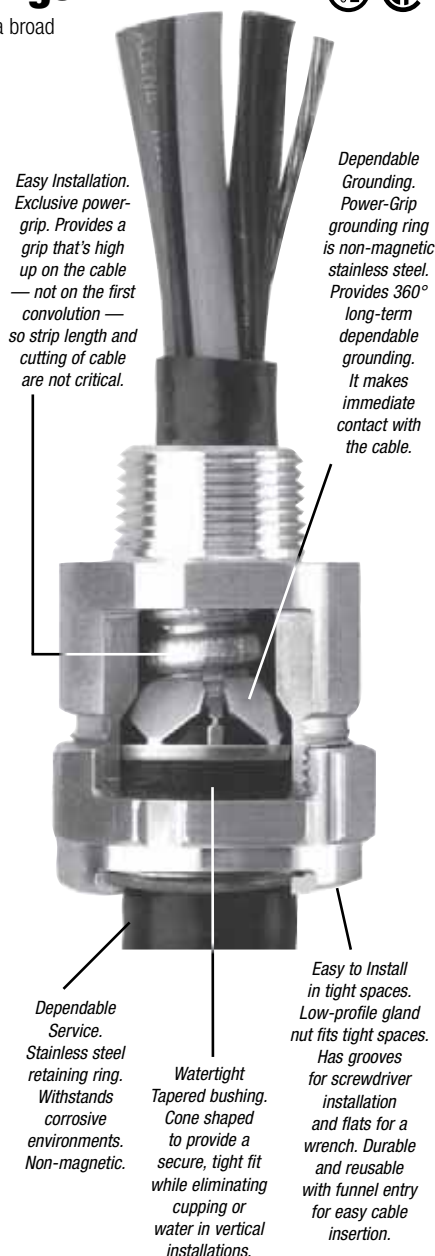

### Installing the STAR TECK® Fitting



1. Prepare cable



2. Insert cable



3. Tighten gland nut

## STAR TECK® Teck Cable Fittings

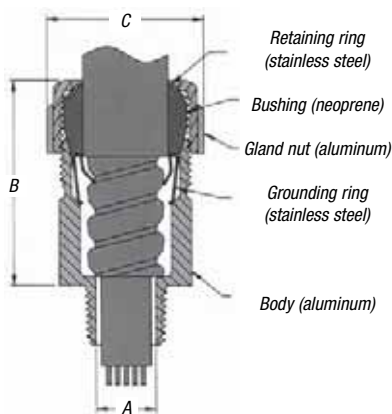

- Overlapping sizes minimize possibility of mismatched cables and fittings in the field
- Available in hub sizes from ½" to 4", handling outer jacket diameters from .525" to 4.34"
- Suitable for hazardous locations (Class 1 Div. 2; Class II Div. 2; Class III)
- Where explosion-proof or dust-proof boxes are required by code, use STAR TECK XP® fittings (STX050-462 Series)

### STAR TECK® Jacketed Metal-Clad Cable Fittings for Ordinary Locations



| CAT. NO.  | HUB SIZE NPT | CABLE RANGE OVER JACKET (IN.) |       | CABLE RANGE OVER ARMOR (IN.) |       | DIMENSIONS (IN.) |       |       |
|-----------|--------------|-------------------------------|-------|------------------------------|-------|------------------|-------|-------|
|           |              | MIN.                          | MAX.  | MIN.                         | MAX.  | A                | B*    | C     |
| ST050-462 | ½            | .525                          | .650  | .415                         | .570  | .395             | 2.020 | 1.224 |
| ST050-464 | ½            | .600                          | .760  | .490                         | .680  | .485             | 2.020 | 1.363 |
| ST050-465 | ½            | .725                          | .885  | .615                         | .805  | .612             | 2.133 | 1.633 |
| ST050-466 | ½            | .825                          | .985  | .715                         | .905  | .612             | 2.133 | 1.633 |
| ST075-467 | ¾            | .880                          | 1.065 | .770                         | .985  | .819             | 2.450 | 2.080 |
| ST075-468 | ¾            | 1.025                         | 1.205 | .915                         | 1.125 | .819             | 2.450 | 2.080 |
| ST100-469 | 1            | 1.187                         | 1.375 | 1.077                        | 1.295 | 1.039            | 2.601 | 2.230 |
| ST125-470 | 1¼           | 1.357                         | 1.625 | 1.240                        | 1.545 | 1.182            | 3.282 | 2.824 |
| ST125-550 | 1¼           | 1.500                         | 1.625 | 1.390                        | 1.545 | 1.370            | 3.282 | 2.824 |
| ST125-471 | 1¼           | 1.600                         | 1.875 | 1.490                        | 1.795 | 1.370            | 3.282 | 2.824 |
| ST150-472 | 1½           | 1.700                         | 1.965 | 1.590                        | 1.885 | 1.557            | 3.620 | 3.260 |
| ST150-473 | 1½           | 1.900                         | 2.187 | 1.790                        | 2.107 | 1.600            | 3.620 | 3.260 |
| ST200-551 | 2            | 1.900                         | 2.187 | 1.790                        | 2.107 | 1.715            | 3.640 | 3.620 |
| ST200-474 | 2            | 2.100                         | 2.375 | 1.990                        | 2.280 | 1.995            | 3.640 | 3.620 |
| ST200-475 | 2            | 2.300                         | 2.565 | 2.190                        | 2.485 | 2.057            | 3.640 | 4.020 |
| ST200-476 | 2            | 2.500                         | 2.750 | 2.390                        | 2.656 | 2.057            | 3.640 | 4.020 |
| ST250-477 | 2½           | 2.380                         | 2.640 | 2.240                        | 2.560 | 2.230            | 4.700 | 4.750 |
| ST250-478 | 2½           | 2.580                         | 2.840 | 2.440                        | 2.750 | 2.430            | 4.700 | 4.750 |
| ST300-479 | 3            | 2.790                         | 3.060 | 2.640                        | 2.970 | 2.630            | 4.700 | 5.050 |
| ST300-480 | 3            | 3.000                         | 3.270 | 2.870                        | 3.190 | 2.860            | 4.790 | 5.480 |
| ST300-481 | 3            | 3.210                         | 3.480 | 3.042                        | 3.390 | 3.032            | 4.790 | 5.480 |
| ST350-482 | 3½           | 3.420                         | 3.690 | 3.270                        | 3.590 | 3.260            | 4.790 | 5.980 |
| ST350-483 | 3½           | 3.610                         | 3.870 | 3.440                        | 3.770 | 3.430            | 4.790 | 5.980 |
| ST400-484 | 4            | 3.810                         | 4.030 | 3.600                        | 3.930 | 3.590            | 4.840 | 6.435 |
| ST400-485 | 4            | 3.965                         | 4.185 | 3.755                        | 4.065 | 3.745            | 4.840 | 6.435 |
| ST400-486 | 4            | 4.120                         | 4.340 | 3.910                        | 4.220 | 3.900            | 4.840 | 6.435 |

\* Approximate dimension before installation.

#### Suggested specifications for metal-clad cable fitting.

1. All metal-clad cable fittings for jacketed interlocked armor cable or continuous corrugated cable shall be approved by a nationally recognized testing laboratory, inspection agency or product evaluation organization.
2. Where corrugated-jacketed metal-clad cable exposed to intermittent or continuous moisture is terminated into a threaded opening, the fitting shall be watertight type furnished with:
  - a. An elastomeric beveled bushing.
  - b. A funnel entry, splined gland nut.
  - c. A non-magnetic stainless steel grounding device with dual grounding action.
  - d. A taper threaded hub.
  - e. A hexagonal body and gland nut as manufactured by Thomas & Betts (aluminum series ST050-464).
3. Where cable is terminated into a threadless opening, a suitable moisture-resistant elastomeric gasket as manufactured by Thomas & Betts, series 5262, shall be provided between the outside of enclosure and fitting shoulder.
4. With single-conductor cable and/or in corrosive environments, aluminum fittings such as Thomas & Betts series ST050-464 shall be installed.

Class I Div 2; Class II Div. 2; Class III. Where explosion-proof or dust-ignition-proof boxes are required by Teck, fitting must be used in conjunction with an approved sealing fitting.



## STAR TECK® Teck Cable Fittings

Easy installation saves time, money!



### STAR TECK XP® Jacketed Metal-Clad Cable Fittings for Hazardous Locations

#### Application

- Provide means for passing armored, metal clad, jacketed cables through a bulkhead or enclosure in hazardous areas (these fittings are suitable for hazardous areas when used with T&B sealing compound)
- Form a mechanical grip and water- and/or oil-resistant termination
- Provide grounding continuity of cable armor

#### Cable Type

- JMC, MC-HL, Teck

#### Features

- Sealing chamber is easier to fill, requires less sealing compound — saves time, material. Flame path is optimally designed to enable easy insertion into hub. Quick-turn lock
- Internal splines
- Union features twist-on action; red color for high visibility
- Exclusive Power Grip. Provides grip that's high up on cable armor non-magnetic stainless steel Power Grip grounding ring
- Low-profile gland nut

#### Materials

Aluminum is standard material

Add suffix "S" for steel with zinc plating

Add suffix "PVC" for corrosion-resistant PVC coating

Add suffix "SS" for stainless steel material

#### Environment Classification

Suitable for hazardous locations. Class I Div. 2; Class II Div. 2; Class III. Where explosion-proof or dust-proof fittings are required by code, use STAR TECK XP® fittings (STX Series)

NEMA 4, 4X (stainless steel)

Suitable for use in wet locations and concrete-tight (steel) applications per UL 514B

UL File No. E82038/E38947

CSA File No. LR23086

#### Range

Available in hub sizes from ½" to 4", and will handle outer jacket diameters from .525" to 4.185"



1. Prepare cable



2. Install Star Teck XP® on cable



3. Tighten gland nut



4. Pot cable (using liquid or putty)



5. Install hub on enclosure



6. Insert cable and tighten red union

Sealing chamber is easier to fill, requires less sealing compound — saves time, material. Flame path is optimally designed to enable easy insertion into hub. Quick-turn lock secures assembly during installation.

Exclusive Power Grip. Provides grip that's high up on cable armor — not on first convolution — so precise cable preparation is not critical. Non-magnetic stainless steel Power Grip grounding ring ensures 360° long-term dependable grounding. It provides phenomenal tensile pullout resistance.

Hub has hexagonal shape for dependable tool grip.

Low-profile gland nut fits tightest spaces. Has grooves for hammer/screwdriver installation and flats for wrench-gripping. Durable and reusable with funnel entry for easy cable insertion.

Internal splines enable installer to tighten gland nut either on or off enclosure.

Tapered bushing. Cone-shaped to provide secure, tight fit while eliminating cupping of water in vertical installations.

Copper-free construction. All-aluminum body and gland nut resist corrosion, oxidation.

Union features twist-on action for easy connection and disconnection; red color ensures high visibility, easy recognition. Union also serves as a "puller" during disassembly.

Stainless steel retaining ring. Withstands corrosive environments. Non-magnetic.

## STAR TECK® Teck Cable Fittings

### STAR TECK XP® Jacketed Metal-Clad Cable Fittings for Hazardous Locations



| CAT. NO.   | HUB SIZE<br>NPT | CABLE RANGE OVER JACKET (IN.) |       | CABLE RANGE OVER ARMOR (IN.) |       | DIMENSIONS (IN.) |      |      | SEALING COMPOUND REQUIRED |                          |
|------------|-----------------|-------------------------------|-------|------------------------------|-------|------------------|------|------|---------------------------|--------------------------|
|            |                 | MIN.                          | MAX.  | MIN.                         | MAX.  | A                | B*   | C    | SC65**<br>PUTTY (G)       | SC4-KIT**<br>LIQUID (CC) |
|            |                 |                               |       |                              |       | MIN.             |      |      |                           |                          |
| STX075-465 | 3/4             | .725                          | .885  | .615                         | .805  | .612             | 2.62 | 1.82 | 14                        | 7                        |
| STX075-466 | 3/4             | .825                          | .985  | .715                         | .905  | .720             | 2.62 | 1.82 | 14                        | 7                        |
| STX100-467 | 1               | .880                          | 1.065 | .770                         | .985  | .755             | 2.83 | 2.30 | 30                        | 16                       |
| STX100-468 | 1               | 1.025                         | 1.205 | .915                         | 1.125 | .900             | 2.83 | 2.30 | 30                        | 16                       |
| STX125-469 | 1 1/4           | 1.187                         | 1.375 | 1.077                        | 1.295 | 1.062            | 3.05 | 2.51 | 45                        | 22                       |
| STX150-470 | 1 1/2           | 1.357                         | 1.625 | 1.240                        | 1.545 | 1.182            | 3.76 | 3.26 | 80                        | 43                       |
| STX150-550 | 1 1/2           | 1.500                         | 1.625 | 1.390                        | 1.545 | 1.370            | 3.76 | 3.26 | 80                        | 43                       |
| STX150-471 | 1 1/2           | 1.600                         | 1.875 | 1.490                        | 1.795 | 1.470            | 3.76 | 3.26 | 80                        | 43                       |
| STX200-472 | 2               | 1.700                         | 1.965 | 1.590                        | 1.885 | 1.557            | 4.05 | 3.62 | 125                       | 66                       |
| STX200-473 | 2               | 1.900                         | 2.187 | 1.790                        | 2.107 | 1.757            | 4.05 | 3.62 | 125                       | 66                       |
| STX200-474 | 2               | 2.100                         | 2.375 | 1.990                        | 2.280 | 1.995            | 4.15 | 4.02 | 150                       | 80                       |
| STX250-475 | 2 1/2           | 2.300                         | 2.565 | 2.200                        | 2.485 | 2.185            | 4.31 | 4.58 | 341                       | 164                      |
| STX250-476 | 2 1/2           | 2.500                         | 2.750 | 2.380                        | 2.656 | 2.365            | 4.31 | 4.58 | 341                       | 164                      |
| STX300-478 | 3               | 2.580                         | 2.840 | 2.477                        | 2.750 | 2.460            | 5.64 | 5.10 | 497                       | 239                      |
| STX300-479 | 3               | 2.790                         | 3.060 | 2.677                        | 2.970 | 2.660            | 5.80 | 5.33 | 609                       | 293                      |
| STX350-480 | 3 1/2           | 3.000                         | 3.270 | 2.880                        | 3.190 | 2.864            | 6.32 | 5.79 | 965                       | 464                      |
| STX350-481 | 3 1/2           | 3.210                         | 3.480 | 3.080                        | 3.390 | 3.062            | 6.32 | 5.79 | 965                       | 464                      |
| STX400-482 | 4               | 3.420                         | 3.690 | 3.307                        | 3.590 | 3.290            | 6.63 | 6.19 | 1323                      | 636                      |
| STX400-483 | 4               | 3.610                         | 3.870 | 3.477                        | 3.770 | 3.460            | 6.63 | 6.19 | 1323                      | 636                      |
| STX400-484 | 4               | 3.810                         | 4.030 | 3.650                        | 3.930 | 3.630            | 7.09 | 6.90 | 1645                      | 791                      |
| STX400-485 | 4               | 3.965                         | 4.185 | 3.794                        | 4.065 | 3.775            | 7.09 | 6.90 | 1645                      | 791                      |

\* Approximate dimension before installation.

\*\* One unit of SC65 putty type sealing compound contains 60 g. One unit of SC4-Kit liquid type sealing compound contains 66 cc and includes a dispensing syringe and fiber damming material.

**CAUTION:** STAR TECK XP® fittings must be installed with Thomas & Betts catalog numbers SC4-KIT or SC65 sealing compound (purchase separately). See installing instructions.

**Note:** Stainless Steel (SS suffix) STX and STEX fittings have a NEMA 4X rating.

### Sealing Compounds

| CAT. NO. | DESCRIPTION  | VOLUME              |
|----------|--|---------------------|
| SC65     | Putty-Type Sealing Compound  | 60 grams            |
| SC4-KIT  | Liquid-Type Sealing Compound for use in high wire density applications (5 or more wires) | 2.8 fl. oz. (66 cc) |

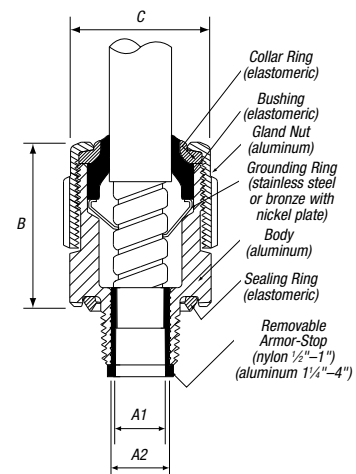

### UL Connectors When Used with Putty-Type Listed or Liquid-Type Compound for:

|              |           |        |                   |
|--------------|-----------|--------|-------------------|
| 1/2" thru 3" | Class I   | Div. 1 | Groups A, B, C, D |
|              | Class II  | Div. 2 | Groups F, G       |
|              | Class III |        |                   |
|              |           |        | Enclosure Type 4  |

### Connectors When Used with Putty-Type or Liquid-Type Compound for:

|             |           |        |                  |
|-------------|-----------|--------|------------------|
| 3 1/2" & 4" | Class I   | Div. 1 | Groups B, C, D   |
|             | Class II  | Div. 2 | Groups F, G      |
|             | Class III |        | Enclosure Type 4 |

### CSA Certified for:

|                               |                  |                   |
|-------------------------------|------------------|-------------------|
| Class I                       | Division 1 and 2 | Groups A, B, C, D |
| Class II                      | Division 1 and 2 | Groups E, F, G    |
| Class III, SL (Integral Seal) |                  | Enclosure Type 4  |

## STAR TECK® Teck Cable Fittings

Greater range, fewer part numbers, less inventory. A fitting combination!

### STAR TECK EXTREME® DIRECTOR™ Jacketed Metal-Clad and Teck Cable Termination Fittings

Terminating jacketed metal-clad and teck cable can be a time-consuming process, especially when angle adjustments are required. Current termination methods such as 90° elbows and LB conduit bodies take up a lot of space and lack flexibility.

To address these issues, Thomas & Betts introduces the electrical industry's first truly adjustable series of range-taking fittings, the STAR TECK EXTREME® DIRECTOR™.

STAR TECK EXTREME® DIRECTOR™ Cable Fittings are designed for optimum integrity in ordinary applications. They accept a range of jacketed metal-clad and teck cable diameters.

Featuring an exclusive swash-plate design, the STAR TECK EXTREME® DIRECTOR™ Cable Fittings adjust from 90° to 180°. A full circular bore makes cable insertion trouble free. Alignment guides serve as handy reference points for aligning installed fittings at the same angle.

What's more, STAR TECK EXTREME® DIRECTOR™ fittings require no disassembly prior to installation and can also be easily disconnected.



## Save Time and Money!

### Install



### Insert

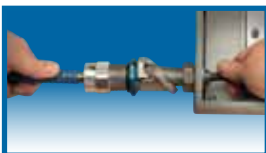

### Rotate



### Conventional Method

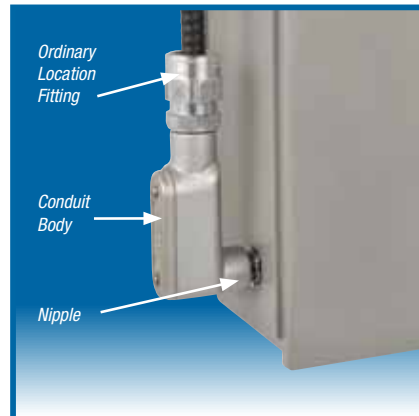

Multiple components are less flexible and require added space.

### Time-Saving Method

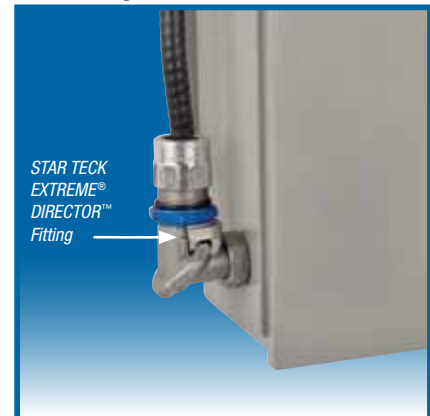

One component that can be used at any angle adds flexibility and requires less space.



Turn blue compression nut one-half turn to loosen and rotate hub. Tighten blue compression nut to hold hub in place at desired angle.

**Thomas & Betts**

United States  
Tel: 901.252.8000  
800.816.7809  
Fax: 901.252.1354

Technical Services  
Tel: 888.862.3289

[www.tnb.com](http://www.tnb.com)



## STAR TECK® Teck Cable Fittings

### STAR TECK EXTREME® DIRECTOR™ Jacketed Metal-Clad and Teck Cable Termination Fittings (continued)

#### Inside STAR TECK EXTREME® DIRECTOR™ Cable Fittings

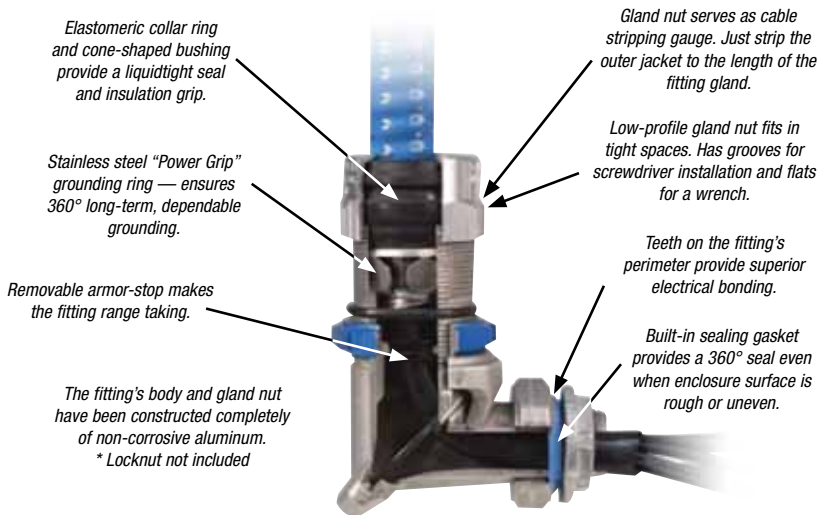

90° to 180° Rotation

#### Environment Classification

Meets NEC® Class I Division 2/Zone 2 and Class II Division 2/Zone 22 requirements when installed as per Articles 501.10/505.15 and 502.10/506.15  
NEMA Type 4  
UL File No. E38947

NEC and National Electrical Code are registered trademarks of the National Fire Protection Association, Inc.

#### STAR TECK EXTREME® DIRECTOR™ Cable Fittings



| CAT. NO. | HUB SIZE (NPT) | GLAND TORQUE (LB.-IN.) | RANGE OVER JACKET (IN.) |       | RANGE OVER ARMOR (IN.) |       | THROAT DIA. MIN. (IN.) |                    | OVERALL LENGTH (IN.) |
|----------|----------------|------------------------|-------------------------|-------|------------------------|-------|------------------------|--------------------|----------------------|
|          |                |                        | MIN.                    | MAX.  | MIN.                   | MAX.  | WITH ARMOR STOP        | WITHOUT ARMOR STOP |                      |
| STED050  | ½              | 450                    | .600                    | .885  | .520                   | .795  | .505                   | .617               | 5.375                |
| STED075  | ¾              | 600                    | .860                    | 1.205 | .780                   | 1.125 | .645                   | .819               | 5.875                |

## STAR TECK® Teck Cable Fittings

### Jacketed Metal-Clad Cable and Teck Cable

#### Metal-Clad Cable (Type MC) Ref. NEC® Article 330

“Metal-Clad Cable Type MC is a factory assembly of one or more conductors, each individually insulated and enclosed in a metallic sheath of interlocking tape, or a smooth or corrugated tube.”

Metal-Clad Cable Type MC is rated for use up to 5,000 volts. The National Electrical Code permits use of metallic sheath as an equipment grounding conductor.

Metal-Clad Cables are available with a variety of phase conductor insulations such as crosslinked polyethylene and silicone rubber ethylene propylene, depending on rated temperature of conductors and working potential. Metallic sheath can be of galvanized steel, aluminum, copper or bronze. A special outer covering such as PVC or Neoprene over metallic sheath is usually provided for environmental protection.

Metal-clad cable is not permitted in locations where it could be subject to physical damage. Metal-clad cable can be used exposed, concealed, in cable tray, in any approved raceway and with minor exceptions in hazardous locations. Type MC cable can also be used for services, feeders, branch circuits, power, lighting, control and signal circuits.

Use of metal-clad cable is permitted in wet locations, or where exposed to destructive corrosive conditions or can be directly buried in earth, concrete or exposed to cinder fills, strong chlorides, caustic alkalis, vapors, chlorine or hydrochloric acids provided the construction of cable, the conductors within the metallic sheath, the metallic sheath and protective cover over metallic sheath comply with requirements enumerated in Sec. 330.10 of the National Electrical Code.

Bend radius restrictions are dependent on the size of the cable and the type of sheath, i.e., smooth, interlocked armor, corrugated sheath or shielded conductors and varies from seven times to 15 times cable external diameter.

NEC Article 330 requires that approved fittings be used for termination. Where single-conductor cables carrying alternating current enter a ferrous metal box or enclosure, procedures described in NEC Section 300.20 must be followed to reduce effects of heating due to induced currents. These procedures include recommended arrangements of conductors, cutting of slots in metal between individual conductor holes, passing of conductors through insulating walls, or use of non-magnetic aluminum sheathed cable and aluminum terminating fittings.

Portions of this section reprinted by permission from NFPA 70, National Electrical Code®, National Fire Protection Association, Boston, MA.

Please refer to the following for further details and complete information:

1. NEC Article 330...Metal Clad Cable (Type MC)
2. UL 4, ANSI C33.9...Safety Standards for Type MC Metal Clad Cable
3. UL 514B, Safety Standards for Outlet Boxes & Fittings
4. A-A50552...Federal Specification. Fittings for Cable, Power Electrical & Conduit Metal, Flexible
5. NEMA FM-1...Standards Publication. Fittings and Supports for Conduit and Cable Assemblies

#### Teck Cables

Teck cable derived its name from one of its first users, the Teck-Hughes Gold Mines in Kirkland Lake, Ontario. Teck 90 is CSA Type designation. Trade designation of this cable is Armored Cable.

Teck cables up to 5,000-volt working potential are manufactured in accordance with CSA Standard C22.2 No. 131 and are provided with a bare ground conductor and an optional outer jacket. Depending on phase conductor insulation, the cables are designated as Teck 90 (X-LINK) when insulation is cross-linked polyethylene and Teck 90 (EP) when insulation is ethylene propylene. Both cables are rated for 90° C service (dry location) and 75° C (wet locations). When Teck cable is suitable for installation down to -40° F, the cables are marked Teck 90 (X-LINK) minus 40 or Teck 90 (EP) minus 40.

Over 5,000 volts working potential Teck cables are manufactured in accordance with IPCEA standards and are certified by CSA. Cables are provided with or without ground wire as required.

Teck cables with outer jacket may be used for exposed or concealed wiring in wet or dry locations, indoors/outdoors and in corrosive environments. Teck cables are suitable for use in ventilated, non-ventilated and ladder-type cable troughs, in ventilated flexible cable ways in both dry and wet locations. Teck cable with outer jacket is suitable for direct earth burial and for Class II Division 2, Class III Division 1 & 2 hazardous locations per Canadian Electric Code.

Some of the features of Teck cable are its flexibility and ease of installation. Absence of dead air space within cable increases heat transfer and minimizes condensation. Overall protective covering provides good environmental protection.

Bend radii for permanent training during installation usually varies between seven times to 12 times the cable diameter depending on cable construction and manufacturer's recommendations. Larger radii bends are required for other conditions.

Section 12-3028 of the Canadian Electric Code requires that the terminating fittings used must provide adequate strain relief to terminal connections and ensure electrical continuity without injury to non-metallic sheath. Continuity is mandatory whether or not the armor is used as a grounding conductor. Except for dry locations free from corrosive atmosphere, the non-metallic jacket is not permitted to be stripped back to a point where armor is exposed after installation.

Where single conductor cables carrying 200 amps or more enter metal boxes through separate openings, certain precautions are required to prevent overheating of the metal by induction. Use of non-ferrous or non-metallic box connectors, locknuts and bushings and installation of non-magnetic panel inserts is suggested in the code.

Please refer to the following for further details and complete information:

1. CEC Section 12...Wiring Methods  
CEC Section 4...Conductors
2. CSA C22.2 No. 131 & 131S  
(Supplement #1)...Safety Standard for Type Teck Cable
3. CSA C22.2 No. 18...Safety Standards for Outlet Boxes, Conduit Boxes and Fittings
4. UL File E82038 — Volume 1, Section 3, Page 1, Revision 1/31/2007

**Note:** The materials herein, whether relating to the National Electrical Code, the Underwriters Laboratories, Inc. listing, to industry practice or otherwise are not intended to provide all relevant information required for use and installation of our products. Refer to applicable codes, instructions and industry specifications prior to installation or use.

## Spin-On® Series Fittings and Accessories

### Spin-On® Series II Connectors and Accessories



| CAT. NO.  | HUB SIZE<br>NPT | CABLE RANGE<br>OVER ARMOR<br>(IN.) | DIMENSIONS (IN.) |    | OPTIONAL<br>CORROSION<br>RESISTANT BOOT<br>CAT. NO. |
|-----------|-----------------|------------------------------------|------------------|----|---|
|           |                 |                                    | A DIA.           | B  |   |
| 2-050-008 | ½               | .380-.435                          | 1¼               | 1½ | NB050   |
| 2-050-010 | ½               | .436-.500                          | 1¼               | 1½ | NB050   |
| 2-050-020 | ½               | .501-.580                          | 1¼               | 1½ | NB050   |
| 2-050-030 | ½               | .581-.650                          | 1¼               | 1½ | NB050   |
| 2-075-040 | ¾               | .651-.730                          | 1½               | 2½ | NB075   |
| 2-075-050 | ¾               | .731-.820                          | 1½               | 2½ | NB075   |
| 2-075-060 | ¾               | .821-.880                          | 1½               | 2½ | NB075   |
| 2-100-070 | 1               | .881-0.960                         | 2                | 2½ | NB100   |
| 2-100-080 | 1               | .961-1.030                         | 2                | 2½ | NB100   |
| 2-100-090 | 1               | 1.031-1.100                        | 2                | 2½ | NB100   |
| 2-100-100 | 1               | 1.101-1.180                        | 2                | 2½ | NB100   |
| 2-125-110 | 1¼              | 1.181-1.240                        | 2¼               | 2½ | NB125   |
| 2-125-120 | 1¼              | 1.241-1.310                        | 2¼               | 2½ | NB125   |
| 2-125-130 | 1¼              | 1.311-1.390                        | 2¼               | 2½ | NB125   |
| 2-150-140 | 1½              | 1.391-1.480                        | 2½               | 2½ | NB150   |
| 2-150-150 | 1½              | 1.481-1.570                        | 2½               | 2½ | NB150   |
| 2-150-160 | 1½              | 1.571-1.660                        | 2½               | 2½ | NB150   |
| 2-200-170 | 2               | 1.661-1.750                        | 3                | 2½ | NB200   |
| 2-200-180 | 2               | 1.751-1.840                        | 3                | 2½ | NB200   |
| 2-200-190 | 2               | 1.841-1.930                        | 3                | 2½ | NB200   |
| 2-200-200 | 2               | 1.931-2.030                        | 3                | 2½ | NB200   |
| 2-250-210 | 2½              | 2.031-2.150                        | 3¾               | 3¾ | NB250   |
| 2-250-220 | 2½              | 2.151-2.270                        | 3¾               | 3¾ | NB250   |
| 2-250-230 | 2½              | 2.271-2.390                        | 3¾               | 3¾ | NB250   |
| 2-250-240 | 2½              | 2.391-2.510                        | 3¾               | 3¾ | NB250   |
| 2-300-250 | 3               | 2.511-2.640                        | 4½               | 3¾ | NB300   |
| 2-300-260 | 3               | 2.641-2.770                        | 4½               | 3¾ | NB300   |
| 2-300-270 | 3               | 2.771-2.900                        | 4½               | 3¾ | NB300   |
| 2-300-280 | 3               | 2.901-3.040                        | 4½               | 3¾ | NB300   |
| 2-350-300 | 3½              | 3.171-3.310                        | 5                | 3¾ | NB350   |
| 2-350-310 | 3½              | 3.311-3.450                        | 5                | 3¾ | NB350   |
| 2-350-320 | 3½              | 3.451-3.590                        | 5                | 3¾ | NB350   |
| 2-400-330 | 4               | 3.591-3.730                        | 5¾               | 3¾ | NB400   |
| 2-400-340 | 4               | 3.731-3.870                        | 5¾               | 3¾ | NB400   |

UL File No. E38947

CSA File No. LR 2884

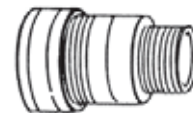

Connector  
Aluminum



In corrosive environments, the T&B neoprene boot provides maximum corrosion protection to the connector. Simply match the connector hub size to the boot hub size to select the proper boot (NB Series).

## Spin-On® Series Fittings and Accessories

Install a complete gas-blocked connector in a hazardous location!  
**Spin-On® X Connectors for Hazardous Locations**

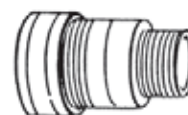

| CAT. NO.  | HUB SIZE<br>NPT | CABLE RANGE<br>OVER ARMOR<br>(IN.) | DIMENSIONS (IN.) |       | SEALING<br>COMPOUND<br>REQUIRED |                          |
|-----------|-----------------|------------------------------------|------------------|-------|---------------------------------|--------------------------|
|           |                 |                                    | A DIA.           | B     | SC65**<br>PUTTY (G)             | SC4-KIT**<br>LIQUID (CC) |
| 4-075-008 | 3/4             | .380-.435                          | 1 1/2            | 2 1/2 | 25                              | 12                       |
| 4-075-010 | 3/4             | .436-.500                          | 1 1/2            | 2 1/2 | 25                              | 12                       |
| 4-075-020 | 3/4             | .501-.580                          | 1 1/2            | 2 1/2 | 25                              | 12                       |
| 4-075-030 | 3/4             | .581-.650                          | 1 1/2            | 2 1/2 | 25                              | 12                       |
| 4-075-040 | 3/4             | .651-.730                          | 1 1/2            | 2 1/2 | 25                              | 12                       |
| 4-100-050 | 1               | .731-.820                          | 2                | 2 1/2 | 55                              | 30                       |
| 4-100-060 | 1               | .821-.880                          | 2                | 2 1/2 | 55                              | 30                       |
| 4-100-070 | 1               | .881-.960                          | 2                | 2 1/2 | 55                              | 30                       |
| 4-100-080 | 1               | .916-1.030                         | 2                | 2 1/2 | 55                              | 30                       |
| 4-125-090 | 1 1/4           | 1.031-1.100                        | 2 1/4            | 2 1/2 | 70                              | 40                       |
| 4-125-100 | 1 1/4           | 1.101-1.880                        | 2 1/4            | 2 1/2 | 70                              | 40                       |
| 4-125-110 | 1 1/4           | 1.181-1.240                        | 2 1/4            | 2 1/2 | 70                              | 40                       |
| 4-125-120 | 1 1/4           | 1.241-1.310                        | 2 1/4            | 2 1/2 | 70                              | 40                       |
| 4-150-130 | 1 1/2           | 1.311-1.390                        | 2 3/4            | 2 3/4 | 80                              | 45                       |
| 4-150-140 | 1 1/2           | 1.181-1.240                        | 2 3/4            | 2 3/4 | 80                              | 45                       |
| 4-150-150 | 1 1/2           | 1.241-1.310                        | 2 3/4            | 2 3/4 | 80                              | 45                       |
| 4-200-160 | 2               | 1.571-1.660                        | 3                | 2 3/4 | 95                              | 55                       |
| 4-200-170 | 2               | 1.661-1.750                        | 3                | 2 3/4 | 95                              | 55                       |
| 4-200-180 | 2               | 1.751-1.840                        | 3                | 2 3/4 | 95                              | 55                       |
| 4-200-190 | 2               | 1.841-1.930                        | 3                | 2 3/4 | 95                              | 55                       |
| 4-250-200 | 2 1/2           | 1.931-2.030                        | 3 3/4            | 3 3/4 | 200                             | 120                      |
| 4-250-220 | 2 1/2           | 2.151-2.270                        | 3 3/4            | 3 3/4 | 200                             | 120                      |
| 4-300-240 | 3               | 2.391-2.510                        | 4 1/2            | 3 3/4 | 275                             | 165                      |
| 4-300-260 | 3               | 2.641-2.770                        | 4 1/2            | 3 3/4 | 275                             | 165                      |
| 4-300-270 | 3               | 2.771-2.900                        | 4 1/2            | 3 3/4 | 275                             | 165                      |
| 4-400-350 | 4               | 3.871-4.010                        | 5 3/4            | 3 3/4 | 500                             | 300                      |

### Spin-On® X Connectors for Hazardous Locations

- Each SPIN-ON® X catalog number is a complete compound-filled connector kit
- 3-piece construction — gland/body/insert with O-ring
- Red anodized gland identifies hazardous location fitting
- Compact size — overall length is 3/8 less than conventional fitting
- Installation time is 50% less than conventional
- Full tapered hub threads for gas-tight thread engagement
- Machined aluminum construction for corrosion resistance
- Sealing compound (sold separately) premixed for consistency — no jobsite variations
- Neoprene boots available for additional corrosion protection
- For control cable applications, order liquid compound separately

Suffix Cat. No. with S for steel, B for brass.

SPIN-ON® X is UL Listed for: Class I, Div. 2, Groups A, B, C, & D in 3/4", 1", 1 1/4", 1 1/2", 2", 2 1/2" Hub sizes. Class I, Div. 2, Groups C & D in 3", 3 1/2", and 4" Hub sizes. The entire line is UL listed for Class II, Div. 2, Groups F & G and Class III. CSA certified through 4" Hub size for Class I, Groups A, B, C, D; Class II, Groups E, F, G; and Class III.

UL File No. E82038

CSA File No. LR23086

## Sealing Compounds

| CAT. NO. | DESCRIPTION  | VOLUME              |
|----------|--|---------------------|
| SC65     | Putty-Type Sealing Compound  | 60 grams            |
| SC4-KIT  | Liquid-Type Sealing Compound for use in high wire density applications (5 or more wires) | 2.8 fl. oz. (66 cc) |

## Metallic Liquidtight Cord and Cable Connectors

**Whatever the application. Whatever the size. Thomas & Betts is your connection to tough, versatile cord and cable fittings.**

Thomas & Betts offers a complete line of rugged, reliable cord and cable fittings. All fittings are produced to the highest standards, combining innovative design and precision manufacturing methods to provide the products you need for your specific applications. Combining proven performance, installation advantages and availability of ranges, T&B is also your connection to lower installed costs for the life of your cord and cable requirements.

Use this guide to help you specify the fitting you need for your cord and cable requirements.

### Cord and Cable Requirements

| CORD AND CABLE TYPE                         | T&B FITTING                                     |
|---|---|
| S, SO, SV, ST, STD, SJ,                     | Ranger® 2920NM# Series, 2920# Series            |
| SJO, SJT, SJTO, SVO                         | Liquidtight Strain Relief 2500# Series          |
| S, SO, SV, ST, STD, SJ, SJO, SJT, SJTO, SVO | Wire Mesh Grips WMG-PC Series for Portable Cord |

### Considerations for Selection

- Selection of the proper device or fitting involves consideration of the type of cable to be installed and the environment that will surround the cable installation.
- A proper matching of the cable and its fitting is necessary to prevent physical damage to the cable when installed.
- NEMA Applications: Fittings used in a trade size knockout requiring a NEMA 3R, 4, 6 or 13 listing require a 5262 Series sealing ring.

### Cord and Cable Descriptions

Type SJ, tradename is Junior Hard Service Cord. The outer covering is Thermoset and it is a pendant or portable cord used in damp locations for hard usage.

Type SJO, tradename is Junior Hard Service Cord. The outer covering is oil-resistant Thermoset.

Type SJT, tradename is Junior Hard Service Cord. The outer covering is Thermoplastic.

Type SJTO, tradename is Junior Hard Service Cord. The outer covering is oil-resistant Thermoplastic.

Type SO, tradename is Hard Service Cord. The outer covering is oil-resistant Thermoset and it is a pendant or portable cord used in damp locations for extra-hard usage.

### Suggested Specifications for Flexible Cord and Cable Fittings

- Flexible cord or cable and associated fittings shall be suitable for conditions of use and location and approved for the purpose by a nationally recognized testing laboratory, inspection agency or product evaluation organization
- Flexible cord or cable shall be so connected to the device or fitting that tension will not be transmitted to joints or terminal screws. Sufficient slack shall be provided to avoid sharp flexing and straining. Cord or cable shall be installed in such a manner that liquid will tend to run off the surface instead of draining towards the fitting
- Where flexible cord or cable exposed to intermittent or constant moisture and subjected to mechanical strain is terminated into a threaded or threadless opening, terminating fittings shall be of watertight strain relief type such as Thomas & Betts series 2920, 2920AL, 2920NM, 2520, 2631 or 2672. Fittings shall be equipped with a beveled moisture-resistant/oil-resistant synthetic rubber bushing
- Where space is limited inside the enclosure, a female hub type fitting such as Thomas & Betts series 2631 shall be furnished. A captivated resilient sealing O-Ring shall be included to positively protect against damage from overtorquing



Conduit & Fittings — T&B® Cord & Cable Fittings





## Metallic Liquidtight Cord and Cable Connectors



2920 Ranger® Series



2920SST Ranger® Series



2920AL Ranger® Series



2516 Series

## Ranger® Series of Liquidtight Flexible Cord and Cable Connectors

### Application

- A liquidtight connector to connect flexible cord or cable to an enclosure and provide adequate strain relief

### Features

- Liquidtight connection with enclosure is ensured by:
  - Taper threaded hub on 2520 series for female hub application
  - Using sealing ring series 5262 with 2520 series for knockout application
  - Captivated sealing O-Ring on 2631 series
  - Neoprene bushing makes liquidtight installation; applies pressure against cable the full length of bushing
  - Thermoplastic or stainless steel retaining ring
    - Will not abrade cord/cable jacket
    - Reduces installing torque effort
- UL Listed liquidtight, strain relief and as an outlet bushing; CSA certified watertight

### Standard Material

Gland, Body.....Steel/Malleable Iron/Zinc Die Cast  
 Retaining Ring.....Thermoplastic/Stainless Steel  
 Bushing.....Neoprene  
 O-Ring.....Buna N

### Standard Finish

Electro Zinc Plated & Chromate Coated

### Range

2520 Series, straight ..... 0.125" outside diameter to 3.200" outside diameter Cord or Cable  
 2200 Series, 45° ..... 0.125" outside diameter to 1.485" outside diameter Cord or Cable

2267 Series, 90° ..... 0.125" outside diameter to 1.875" outside diameter Cord or Cable  
 2900 and 4900 Ranger® Series ..... 0.250" cable range  
 Cord/Cable Type ..... S, SO, SV, ST, STO, SJ, SJO, SJT, SJTO, SVO & SVT

### Listings/Compliances

UL File No. E-13938  
 CSA LR-589, LR-4484  
 UL 514  
 CSA. 22.2 No. 18  
 ANSI C33.84, NFPA 70-1978 (ANSI)

| CAT. NO            | SIZE | MIN. | MAX. | SVO, SV, SVT | SJ, SJO, SJT, SJTO |     |     | S, SO, ST, STO |     |     |     |     |    |    |
|--------------------|------|------|------|--------------|--------------------|-----|-----|----------------|-----|-----|-----|-----|----|----|
|                    |      |      |      | #18          | #18                | #16 | #14 | #18            | #16 | #14 | #12 | #10 | #8 | #6 |
| <b>2 Conductor</b> |      |      |      |              |                    |     |     |                |     |     |     |     |    |    |
| 2920               | 1/2" | .125 | .375 | X            | X                  | X   | X   |                |     |     |     |     |    |    |
| 2921               | 1/2" | .310 | .560 |              |                    | X   | X   | X              | X   | X   |     |     |    |    |
| 2922               | 1/2" | .500 | .750 |              |                    |     | X   | X              | X   | X   | X   | X   |    |    |
| 2930               | 3/4" | .125 | .375 | X            | X                  | X   | X   |                |     |     |     |     |    |    |
| 2931               | 3/4" | .310 | .560 |              |                    | X   | X   | X              | X   | X   |     |     |    |    |
| 2932               | 3/4" | .500 | .750 |              |                    |     | X   | X              | X   | X   | X   | X   |    |    |
| 2940               | 1"   | .310 | .560 |              |                    | X   | X   | X              | X   | X   |     |     |    |    |
| 2941               | 1"   | .500 | .750 |              |                    |     | X   | X              | X   | X   | X   | X   |    |    |
| 2942               | 1"   | .700 | .950 |              |                    |     | X   |                |     |     |     |     | X  | X  |
| <b>3 Conductor</b> |      |      |      |              |                    |     |     |                |     |     |     |     |    |    |
| 2920               | 1/2" | .125 | .375 | X            | X                  | X   |     |                |     |     |     |     |    |    |
| 2921               | 1/2" | .310 | .560 |              | X                  | X   | X   | X              | X   |     |     |     |    |    |
| 2922               | 1/2" | .500 | .750 |              |                    |     |     |                |     | X   | X   | X   |    |    |
| 2930               | 3/4" | .125 | .375 | X            | X                  | X   |     |                |     |     |     |     |    |    |
| 2931               | 3/4" | .310 | .560 |              | X                  | X   | X   | X              | X   |     |     |     |    |    |
| 2932               | 3/4" | .500 | .750 |              |                    |     |     |                |     | X   | X   | X   |    |    |
| 2940               | 1"   | .310 | .560 |              |                    | X   | X   | X              | X   |     |     |     |    |    |
| 2941               | 1"   | .500 | .750 |              | X                  |     |     |                |     | X   | X   | X   |    |    |
| 2942               | 1"   | .700 | .950 |              |                    |     |     |                |     |     |     | X   | X  |    |
| <b>4 Conductor</b> |      |      |      |              |                    |     |     |                |     |     |     |     |    |    |
| 2920               | 1/2" | .125 | .375 | X            |                    |     |     |                |     |     |     |     |    |    |
| 2921               | 1/2" | .310 | .560 |              | X                  | X   | X   | X              | X   |     |     |     |    |    |
| 2922               | 1/2" | .500 | .750 |              |                    |     |     |                |     | X   | X   |     |    |    |
| 2930               | 3/4" | .125 | .375 | X            |                    |     |     |                |     |     |     |     |    |    |
| 2931               | 3/4" | .310 | .560 |              | X                  | X   | X   | X              | X   |     |     |     |    |    |
| 2932               | 3/4" | .500 | .750 |              |                    |     |     |                |     | X   | X   |     |    |    |
| 2940               | 1"   | .310 | .560 |              | X                  | X   | X   | X              | X   |     |     |     |    |    |
| 2941               | 1"   | .500 | .750 |              |                    |     |     |                |     | X   | X   |     |    |    |
| 2942               | 1"   | .700 | .950 |              |                    |     |     |                |     |     | X   | X   |    |    |

## Metallic Liquidtight Cord and Cable Connectors

### The Ranger® Series of Steel Liquidtight Cord Connectors

The Ranger® Series Steel Liquidtight Connector takes twice the cable range of most ordinary strain-relief connectors. T&B's Ranger Connectors enable you to reduce your inventory and save time with one connector that can do the work of two.



#### Features

- Extended range with superior strain relief
- Reduced overall size, fits into tighter spaces
- Gland nut designed to restrict cable bending

#### Materials

Body: Steel — 2920 series,  
Malleable Iron — 4920  
& 4960 series

Gland Nut, Grip: Steel — all series  
Bushing: Rubber

#### Environment Classification

- Ordinary locations
- Wet or dry locations
- Fittings used in a trade size knockout requiring a NEMA 3R, 4, 6 or 13 listing require a 5262 Series sealing ring

#### Range

Cord Range: .125" to .950"

Hub Size Range: 1/2" to 1"

#### Application

- Provide means for passing a cord cable into an enclosure, through a bulkhead or into a rigid conduit
- Form a mechanical grip and water- and/or oil-resistant seal for cord
- Form a non-slip connection or termination for flexible cord

#### Cord & Cable Type

- S, SO, SV, ST, STD, SJ, SJO, SJT, SJTO, SVD

### Steel Liquidtight Strain Relief Connectors — 90° Angle

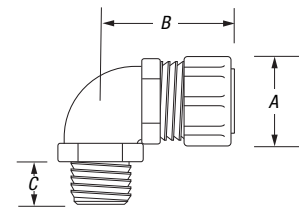

| CAT. NO. | HUB SIZE | THROAT DIA. | CORD RANGE | DIMENSIONS (IN.) |         |        |
|----------|----------|-------------|------------|------------------|---------|--------|
|          |          |             |            | A                | B       | C      |
| 4960     | 1/2"     | 19/32       | .125-.375  | 1 1/8            | 1 3/4   | 5/8    |
| 4961     | 1/2"     | 19/32       | .310-.560  | 1 1/8            | 1 3/4   | 5/8    |
| 4962     | 1/2"     | 19/32       | .500-.750  | 1 1/8            | 1 23/64 | 5/8    |
| 4970     | 3/4"     | 25/32       | .125-.375  | 1 1/8            | 1 25/32 | 11/16  |
| 4971     | 3/4"     | 25/32       | .310-.560  | 1 1/8            | 1 25/32 | 11/16  |
| 4972     | 3/4"     | 25/32       | .500-.750  | 1 1/8            | 1 25/32 | 11/16  |
| 4980     | 1"       | 1           | .310-.560  | 1 1/8            | 2 1/2   | 1 1/16 |

All items shown on this page are suitable for use in hazardous locations where general-purpose equipment is specifically permitted by the NEC®, NEC 501-4(b).

UL File No. E-13938

CSA File No. 52391

### Steel Liquidtight Strain Relief Connectors — 45° Angle

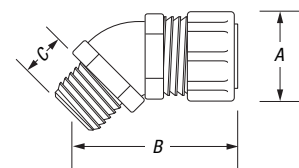

| CAT. NO. | HUB SIZE | THROAT DIA. | CORD RANGE | DIMENSIONS (IN.) |        |       |
|----------|----------|-------------|------------|------------------|--------|-------|
|          |          |             |            | A                | B      | C     |
| 4920     | 1/2"     | 37/64       | .125-.375  | 1 1/8            | 1 1/16 | 47/64 |
| 4921     | 1/2"     | 37/64       | .310-.560  | 1 1/8            | 1 1/16 | 47/64 |
| 4922     | 1/2"     | 37/64       | .500-.750  | 1 1/8            | 1 1/16 | 47/64 |
| 4930     | 3/4"     | 25/32       | .125-.375  | 1 1/8            | 1 7/16 | 5/8   |
| 4931     | 3/4"     | 25/32       | .310-.560  | 1 1/8            | 1 7/16 | 5/8   |
| 4932     | 3/4"     | 25/32       | .500-.750  | 1 1/8            | 1 7/16 | 5/8   |

For wire mesh grips, refer to page E-142.

### Steel Liquidtight Strain Relief Connectors — Straight

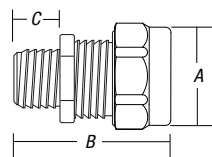

| CAT. NO. | HUB SIZE | THROAT DIA. | CORD RANGE | DIMENSIONS (IN.) |         |       |
|----------|----------|-------------|------------|------------------|---------|-------|
|          |          |             |            | A                | B       | C     |
| 2920     | 1/2"     | 47/64       | .125-.375  | 1 1/8            | 1 3/4   | 5/8   |
| 2921     | 1/2"     | 47/64       | .310-.560  | 1 1/8            | 1 3/4   | 5/8   |
| 2922     | 1/2"     | 47/64       | .500-.750  | 1 1/8            | 1 3/4   | 5/8   |
| 2930     | 3/4"     | 1 1/16      | .125-.375  | 1 1/8            | 1 25/32 | 5/8   |
| 2931     | 3/4"     | 1 1/16      | .310-.560  | 1 1/8            | 1 25/32 | 5/8   |
| 2932     | 3/4"     | 1 1/16      | .500-.750  | 1 1/8            | 1 25/32 | 5/8   |
| 2940     | 1"       | 1 1/16      | .310-.560  | 1 1/8            | 1 3/4   | 3/4   |
| 2941     | 1"       | 1 1/16      | .500-.750  | 1 1/8            | 1 3/4   | 3/4   |
| 2942     | 1"       | 3 1/2       | .700-.950  | 1 1/8            | 1 7/8   | 3 1/2 |

## Metallic Liquidtight Cord and Cable Connectors

### The Ranger® Series of Non-Metallic Liquidtight Cord Connectors

The Ranger® Series Non-Metallic Liquidtight Cord Connector takes twice the cable range of most ordinary strain-relief connectors. T&B's Ranger Connectors enable you to reduce your inventory and save time with one connector that can do the work of two. The sturdy nylon material adds corrosion resistance to your installation.



#### Application

- Provide means for passing a cord into an enclosure or through a bulkhead or into a rigid conduit
- Form a mechanical grip and water- and/or oil-resistant seal for cord
- Form a nonslip connection or termination for flexible cord, cable (armored or unarmored)

#### Cord & Cable Type

- S, SO, SV, ST, STD, SJ, SJO, SJT, SJTO, SVD

#### Features

- Extended range with superior strain relief
- Reduced overall size, fits into tighter spaces
- Gland nut designed to restrict cable bending

#### Materials

Weather-stabilized nylon, temperature rated -34° C to 105° C

Bushing: Rubber

#### Environment Classification

Ordinary locations

Wet or dry locations

Fittings used in a trade size knockout requiring a NEMA 3R, 4, 6 or 13 listing require a 5262 Series sealing ring

#### Range

Cord Range: Straight — .125" to .950"

90° — .125" to .750"

Hub Size Range: Straight — ½" to 1"

90° — ½" to ¾"

#### Listings/Compliances

UL Type 6 and 4X

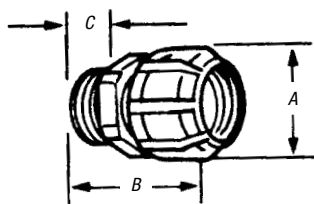

Non-Metallic Liquidtight Strain Relief Connector — Straight

| CAT. NO. | TRADE OR HUB SIZE | THROAT DIA. | CORD RANGE | DIMENSIONS (IN.)                |                                 |                                |
|----------|-------------------|-------------|------------|---------------------------------|---------------------------------|--------------------------------|
|          |                   |             |            | A                               | B                               | C                              |
| 2920NM   | ½"                | .55         | .125–.375  | 1 <sup>1</sup> / <sub>32</sub>  | 2 <sup>1</sup> / <sub>8</sub>   | 5 <sup>1</sup> / <sub>8</sub>  |
| 2921NM   | ½"                | .55         | .310–.560  | 1 <sup>1</sup> / <sub>32</sub>  | 2 <sup>1</sup> / <sub>8</sub>   | 5 <sup>1</sup> / <sub>8</sub>  |
| 2922NM   | ½"                | .55         | .500–.750  | 1 <sup>13</sup> / <sub>32</sub> | 2 <sup>5</sup> / <sub>32</sub>  | 5 <sup>1</sup> / <sub>8</sub>  |
| 2930NM   | ¾"                | .79         | .125–.375  | 1 <sup>13</sup> / <sub>32</sub> | 2 <sup>3</sup> / <sub>16</sub>  | 5 <sup>1</sup> / <sub>8</sub>  |
| 2931NM   | ¾"                | .79         | .310–.560  | 1 <sup>13</sup> / <sub>32</sub> | 2 <sup>3</sup> / <sub>16</sub>  | 5 <sup>1</sup> / <sub>8</sub>  |
| 2932NM   | ¾"                | .79         | .500–.750  | 1 <sup>13</sup> / <sub>32</sub> | 2 <sup>3</sup> / <sub>16</sub>  | 5 <sup>1</sup> / <sub>8</sub>  |
| 2940NM   | 1"                | .98         | .310–.560  | 1 <sup>13</sup> / <sub>32</sub> | 2 <sup>11</sup> / <sub>32</sub> | 2 <sup>5</sup> / <sub>32</sub> |
| 2941NM   | 1"                | .98         | .500–.750  | 1 <sup>13</sup> / <sub>32</sub> | 2 <sup>11</sup> / <sub>32</sub> | 2 <sup>5</sup> / <sub>32</sub> |
| 2942NM   | 1"                | .98         | .700–.950  | 1 <sup>43</sup> / <sub>64</sub> | 2 <sup>3</sup> / <sub>8</sub>   | 2 <sup>5</sup> / <sub>32</sub> |

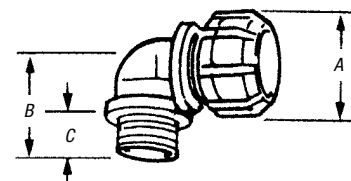

Non-Metallic Liquidtight Strain Relief Connector — 90° Elbow

| CAT. NO. | TRADE OR HUB SIZE | THROAT DIA. | CORD RANGE | DIMENSIONS (IN.)                |                               |                               |
|----------|-------------------|-------------|------------|---------------------------------|-------------------------------|-------------------------------|
|          |                   |             |            | A                               | B                             | C                             |
| 4960NM   | ½"                | .55         | .125–.375  | 1 <sup>1</sup> / <sub>32</sub>  | 1 <sup>1</sup> / <sub>4</sub> | 5 <sup>1</sup> / <sub>8</sub> |
| 4961NM   | ½"                | .55         | .310–.560  | 1 <sup>1</sup> / <sub>32</sub>  | 1 <sup>1</sup> / <sub>4</sub> | 5 <sup>1</sup> / <sub>8</sub> |
| 4970NM   | ¾"                | .79         | .125–.375  | 1 <sup>13</sup> / <sub>32</sub> | 1 <sup>3</sup> / <sub>8</sub> | 5 <sup>1</sup> / <sub>8</sub> |
| 4971NM   | ¾"                | .79         | .310–.560  | 1 <sup>13</sup> / <sub>32</sub> | 1 <sup>3</sup> / <sub>8</sub> | 5 <sup>1</sup> / <sub>8</sub> |
| 4972NM   | ¾"                | .79         | .500–.750  | 1 <sup>13</sup> / <sub>32</sub> | 1 <sup>3</sup> / <sub>8</sub> | 5 <sup>1</sup> / <sub>8</sub> |

UL File No. E 13938  
 CSA File No. 52391  
 Meets Coast Guard CG293

## Metallic Liquidtight Cord and Cable Connectors

Type 304 stainless construction for your harshest environments!

## The Ranger® Series of Stainless Steel Liquidtight Cord Connectors

Until now, there's been no ideal solution for liquidtight connections of portable cord to a box or enclosure in corrosive environments. Steel connectors rust, and non-metallic connectors can't withstand high temperatures or ultraviolet exposure.

In response to customer demand, Thomas & Betts has developed the latest addition to its high-performance line of Ranger® Cord Connectors. Made of Type 304 stainless steel, Ranger® Stainless Steel Liquidtight Cord Connectors stand up to highly corrosive environments — such as washdown areas in food and beverage or pharmaceutical processing — as well as high temperatures and UV exposure.

### Application

- Provide means for passing a cord cable into an enclosure, through a bulkhead or into a rigid conduit
- Form a mechanical grip and water- and/or oil-resistant seal for cord
- Form a non-slip connection or termination for flexible cord

### Cord & Cable Type

- SJ, SJE, SJE0, SJE00, SJO, SJOW, SJO0, SJOOW, SJT, SJTW, SJTO, SJTOW, SJTO0, SJTOOW, SO, SOW, SOO, SOOW, SV, ST, STD, SVD

### Features

- Extended range with superior strain relief
- Reduced overall size, fits into tighter spaces
- Gland nut designed to restrict cable bending

### Materials

Body, Gland Nut, Grip ..... Type 304 stainless steel  
 Bushing.....Thermoplastic rubber  
 Grip Ring.....Nylon  
 O-Ring (supplied)..... Buna N

### Environment Classification

Ordinary locations (wet or dry)  
 Temperature Rating .....-20° C to 105° C (-4° F to 221° F)

### Range

Cord Range ..... .125" to .950"  
 Hub Size Range ..... ½" to 1"

### Listings/Compliances

¼" and ⅜" Sizes ..... UL Recognized  
 ½" through 1" Sizes .....UL Listed and CSA Certified for use with portable cord; UL514B liquidtight cord connectors; UL Type 6 and 4X

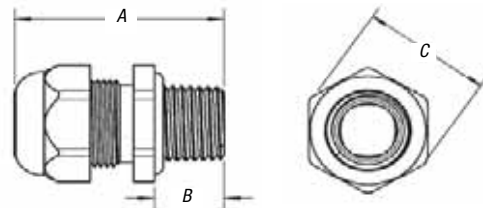

### Stainless Steel Cable Glands — ¼"–⅜" Hub Sizes



| CAT. NO. | HUB SIZE (IN.) | CORD DIA. RANGE (IN.) | DIMENSIONS (IN.) |      |      | STD. PKG. QTY. |
|----------|----------------|-----------------------|------------------|------|------|----------------|
|          |                |                       | A                | B    | C    |                |
| 2918SST  | ¼              | .118–.256             | 1.000            | .250 | .625 | 25             |
| 2919SST  | ⅜              | .157–.315             | 1.313            | .438 | .750 | 25             |

### Stainless Steel Liquidtight Strain-Relief Cord Connectors — ½"–1" Hub Sizes



| CAT. NO. | HUB SIZE (IN.) | CORD DIA. RANGE (IN.) | DIMENSIONS (IN.) |      |       | STD. PKG. QTY. |
|----------|----------------|-----------------------|------------------|------|-------|----------------|
|          |                |                       | A                | B    | C     |                |
| 2920SST  | ½              | .125–.375             | 1.935            | .610 | 1.125 | 25             |
| 2921SST  | ½              | .310–.560             | 1.935            | .610 | 1.125 | 25             |
| 2922SST  | ½              | .500–.750             | 2.003            | .610 | 1.125 | 25             |
| 2930SST  | ¾              | .125–.375             | 2.063            | .630 | 1.125 | 10             |
| 2931SST  | ¾              | .310–.560             | 2.063            | .630 | 1.125 | 10             |
| 2932SST  | ¾              | .500–.750             | 2.063            | .630 | 1.125 | 10             |
| 2940SST  | 1              | .310–.560             | 2.178            | .785 | 1.500 | 10             |
| 2941SST  | 1              | .500–.750             | 2.218            | .785 | 1.500 | 10             |
| 2942SST  | 1              | .700–.950             | 2.218            | .785 | 1.500 | 10             |

## Metallic Liquidtight Cord and Cable Connectors

### The Ranger® Series of Aluminum Liquidtight Cord Connectors

#### Application

- A liquidtight connector to connect flexible cord to an enclosure and provide adequate strain relief
- Form a mechanical grip and water and liquidtight seal
- Form a non-slip connection or termination for flexible cord

#### Cord & Cable Type

- SJ, SJE, SJEW, SJE0, SJE00, SJE00W, SJO, SJOW, SJO0, SJO0W, SJT, SJTW, SJTO, SJTOW, SJTO0, SJTO0W, SO, SOW, SO0, SO0W, SV, ST, STD, SVD

#### Features

- Available in straight or 90° designs
- Designed to accept a wide range of cables, offering nine fittings that cover cord ranges from .125" through .950"
- Slotted design gland nut to accommodate securing in tight spaces

- Installer can simply use screwdriver to get into the hard-to-reach area and secure the gland nut
- Marked with cable ranges and conduit hub sizes

#### Material

Body ..... Copper-Free Aluminum  
 Gland Nut, Grip..... Copper-Free Aluminum — All Series  
 Bushing..... Thermoplastic Rubber  
 Grip Ring..... Nylon

#### Environment Classification

Ordinary locations  
 Wet or dry locations  
 Temperature Range: -20° C to 105° C (-4° F to 221° F)

#### Range

Cord Range: .125" to .950"  
 Hub Size Range: ½" to 1"

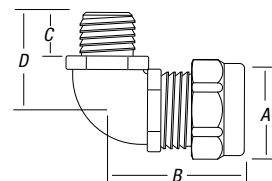
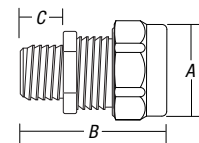

#### Aluminum Liquidtight Strain-Relief Connectors

| CAT. NO.         | HUB SIZE | CORD RANGE (IN.) | DIMENSIONS (IN.) |    |    |    | STD. PKG. QTY. | WT. PER 100 |
|------------------|----------|------------------|------------------|----|----|----|----------------|-------------|
|                  |          |                  | A                | B  | C  | D  |                |             |
| <b>Straight</b>  |          |                  |                  |    |    |    |                |             |
| 2920AL           | ½"       | .125-.375        | 1½               | 1¾ | ¾  | —  | 25             | 8.50        |
| 2921AL           | ½"       | .310-.560        | 1½               | 1¾ | ¾  | —  | 25             | 8.05        |
| 2922AL           | ½"       | .500-.750        | 1½               | 1¾ | ¾  | —  | 25             | 9.95        |
| 2930AL           | ¾"       | .125-.375        | 1½               | 1¾ | ¾  | —  | 10             | 12.30       |
| 2931AL           | ¾"       | .310-.560        | 1½               | 1¾ | ¾  | —  | 10             | 11.90       |
| 2932AL           | ¾"       | .500-.750        | 1½               | 1¾ | ¾  | —  | 10             | 11.50       |
| 2940AL           | 1"       | .310-.560        | 1½               | 1¾ | 1½ | —  | 10             | 18.00       |
| 2941AL           | 1"       | .500-.750        | 1½               | 1¾ | 1½ | —  | 10             | 16.00       |
| 2942AL           | 1"       | .700-.950        | 1½               | 1¾ | 3¼ | —  | 10             | 16.70       |
| <b>90° Elbow</b> |          |                  |                  |    |    |    |                |             |
| 4960AL           | ½"       | .125-.375        | 1½               | 1¾ | ¾  | 1½ | 50             | 23.60       |
| 4961AL           | ½"       | .360-.560        | 1½               | 1¾ | ¾  | 1½ | 50             | 11.60       |
| 4970AL           | ¾"       | .125-.375        | 1½               | 1¾ | ¾  | 1½ | 50             | 17.2        |
| 4971AL           | ¾"       | .310-.560        | 1½               | 1¾ | ¾  | 1½ | 50             | 30.00       |
| 4972AL           | ¾"       | .500-.750        | 1½               | 1¾ | ¾  | 1½ | 50             | 33.09       |
| 4980AL           | 1"       | .310-.560        | 1½               | 2¼ | ¾  | 1¾ | 25             | 21.50       |
| 4981AL           | 1"       | .500-.750        | 1½               | 2¼ | ¾  | 1¾ | 25             | 22.36       |
| 4982AL           | 1"       | .700-.950        | 1½               | 2¼ | ¾  | 2  | 25             | 18.20       |

\* It may be necessary to remove sufficient outer covering of cable to permit conductors to pass through connector body.  
 All items shown on this page are suitable for use in hazardous locations where general-purpose equipment is specifically permitted by the NEC®, NEC 501-4(b).

UL File No. E-13938 CSA File No. 52391

For wire mesh grips, refer to page E-142.



## Metallic Liquidtight Cord and Cable Connectors

### T&B® Liquidtight Strain-Relief Cord Connectors



The T&B Steel Liquidtight Strain Relief Cord Connector is suited for most general control and power cable applications. This series features sturdy neoprene bushings and tapered hub threads.

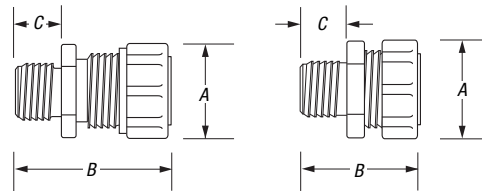

Fig. 1

Fig. 2



#### Application

- Provide means for passing a cord cable (armored or unarmored) into an enclosure, through a bulkhead or into a rigid conduit
- Form a mechanical grip and water- and/or oil-resistant seal for cord and unarmored or jacketed armored round cables
- Form a non-slip connection or termination for flexible cord, cable (armored or unarmored)
- Provide grounding continuity of cable armor

#### Cord & Cable Type

- S, SO, SV, ST, STD, SJ, SJO, SJT, SJTO, SVD

#### Features

- Extended range with superior strain relief
- Reduced overall size, fits into tighter spaces
- Gland nut designed to restrict cable bending

#### Materials

Body..... Cat. Nos. 2516–2519 — Steel  
 Cat. Nos. 2520–2596 — Malleable Iron or Die-Cast Zinc  
 2200 Series — Malleable Iron  
 Gland..... Steel  
 Bushing..... Neoprene

#### Environment Classification

Ordinary locations  
 Wet or dry locations  
 Fittings used in a trade size knockout requiring a NEMA 3R, 4, 6 or 13 listing require a 5262 Series sealing ring

UL Listed as liquidtight strain relief and outlet bushing.  
 CSA certified watertight.

UL File No. E 13938

CSA File No. 589 & 4484

† UL not applicable.

\* Remove sufficient outer covering of cable to permit conductors to pass through connector body.

Complies with JIC standards.

Temperature rating 105° C.

Suitable for hazardous locations use where general-purpose equipment is specifically permitted per NEC® Section 501-4(b).

| CAT. NO. | CABLE SIZE (IN) |     | HUB SIZE | THROAT DIA. (MIN.) | FIG. | DIMENSIONS (IN.) |       |              | BUSHING PART NO. | GLAND-NUT MODEL NO. | RETAINER MODEL NO. | BODY MODEL NO. |
|----------|-----------------|-----|----------|--------------------|------|------------------|-------|--------------|------------------|---------------------|--------------------|----------------|
|          | RANGE MIN.-MAX. |     |          |                    |      | A                | B     | C            |                  |                     |                    |                |
| 2516†    | .060–.125       | ¼"  | ⅜"       | 2                  | 3/64 | 17/16            | 15/32 | 035-73377-5  | 035-73377-3      | 035-73377-9         | 035-73377-1        |                |
| 2517†    | .120–.250       | ¼"  | ⅜"       | 2                  | 1/64 | 17/16            | 15/32 | 035-73377-6  | 035-73377-3      | 035-73377-9         | 035-73377-1        |                |
| 2518†    | .060–.150       | ⅜"  | ⅝"       | 2                  | 3/32 | 1½               | 15/32 | 035-73377-7  | 035-73377-4      | 035-73377-9         | 035-73377-2        |                |
| 2519†    | .150–.300       | ⅜"  | ⅝"       | 2                  | 3/32 | 1½               | 15/32 | 035-73377-8  | 035-73377-4      | 035-73377-9         | 035-73377-2        |                |
| 2520     | .125–.250       | ½"  | ⅞"       | 1                  | 1½   | 1½               | 5/8   | 053-71411-1  | 053-71411-37     | 035-72735-1         | 053-71411-43       |                |
| 2521     | .250–.375       | ½"  | ⅞"       | 1                  | 1½   | 1½               | 5/8   | 053-71411-2  | 053-71411-37     | 035-72735-1         | 053-71411-43       |                |
| 2522     | .375–.500       | ½"  | ⅞"       | 1                  | 1½   | 1½               | 5/8   | 053-71411-3  | 053-71411-37     | 035-72735-2         | 053-71411-43       |                |
| 2523     | .450–.560       | ½"  | ⅞"       | 1                  | 1½   | 1½               | 5/8   | 053-71411-4  | 053-71411-37     | 035-72735-2         | 053-71411-43       |                |
| 2524*    | .500–.625       | ½"  | ⅞"       | 1                  | 1½   | 1¾               | 5/8   | 053-71411-59 | 053-71411-38     | 035-72735-3         | 033-72259-21       |                |
| 2525*    | .625–.750       | ½"  | ⅞"       | 1                  | 1½   | 1¾               | 5/8   | 053-71411-60 | 053-71411-38     | 035-72735-3         | 033-72259-21       |                |
| 2530     | .125–.250       | ¾"  | 1⅜"      | 1                  | 1½   | 1¾               | 5/8   | 033-72259-1  | 053-71411-38     | 035-72735-4         | 053-71411-44       |                |
| 2531     | .250–.375       | ¾"  | 1⅜"      | 1                  | 1½   | 1¾               | 5/8   | 053-71411-5  | 053-71411-38     | 035-72735-4         | 053-71411-44       |                |
| 2532     | .375–.500       | ¾"  | 1⅜"      | 1                  | 1½   | 1¾               | 5/8   | 053-71411-58 | 053-71411-38     | 035-72735-4         | 053-71411-44       |                |
| 2534     | .500–.625       | ¾"  | 1⅜"      | 1                  | 1½   | 1¾               | 5/8   | 053-71411-59 | 053-71411-38     | 035-72735-3         | 053-71411-44       |                |
| 2535     | .625–.750       | ¾"  | 1⅜"      | 1                  | 1½   | 1¾               | 5/8   | 053-71411-60 | 053-71411-38     | 035-72735-3         | 053-71411-44       |                |
| 2536*    | .750–.880       | ¾"  | 1⅜"      | 1                  | 1½   | 1⅞               | 5/8   | 053-71411-61 | 053-71411-39     | 035-72735-5         | 033-72259-22       |                |
| 2541     | .250–.375       | 1"  | 1⅞"      | 1                  | 1½   | 1⅞               | 5/8   | 053-71411-5  | 053-71411-38     | 035-72735-4         | 053-71411-45       |                |
| 2542     | .375–.500       | 1"  | 1⅞"      | 1                  | 1½   | 1⅞               | 5/8   | 053-71411-58 | 053-71411-38     | 035-72735-4         | 053-71411-45       |                |
| 2544     | .500–.625       | 1"  | 1⅞"      | 1                  | 1½   | 1⅞               | 5/8   | 053-71411-59 | 053-71411-38     | 035-72735-3         | 053-71411-45       |                |
| 2545     | .625–.750       | 1"  | 1⅞"      | 1                  | 1½   | 1⅞               | 5/8   | 053-71411-60 | 053-71411-38     | 035-72735-3         | 053-71411-45       |                |
| 2546     | .750–.880       | 1"  | 1⅞"      | 1                  | 1½   | 1⅞               | 5/8   | 053-71411-61 | 053-71411-39     | 035-72735-5         | 053-71411-46       |                |
| 2547     | .875–.985       | 1"  | 1⅞"      | 1                  | 1½   | 1⅞               | 5/8   | 053-71411-62 | 053-71411-39     | 035-72735-5         | 053-71411-46       |                |
| 2548*    | .880–1.065      | 1"  | 1⅞"      | 1                  | 2½   | 2½               | 5/8   | 053-71411-63 | 053-71411-40     | 035-72735-6         | 033-72259-23       |                |
| 2549*    | 1.065–1.205     | 1"  | 1⅞"      | 1                  | 2½   | 2½               | 5/8   | 053-71411-64 | 053-71411-40     | 035-72735-6         | 033-72259-23       |                |
| 2558     | .880–1.065      | 1¼" | 1⅞"      | 1                  | 2½   | 2½               | 5/8   | 053-71411-63 | 053-71411-40     | 035-72735-6         | 053-71411-47       |                |
| 2559     | 1.065–1.205     | 1¼" | 1⅞"      | 1                  | 2½   | 2½               | 5/8   | 053-71411-64 | 053-71411-40     | 035-72735-6         | 053-71411-47       |                |
| 2556*    | 1.187–1.375     | 1¼" | 1⅞"      | 1                  | 2½   | 2½               | 5/8   | 053-71411-18 | 053-71411-41     | 035-72735-7         | 033-72259-24       |                |
| 2557*    | 1.375–1.485     | 1¼" | 1⅞"      | 1                  | 2½   | 2½               | 5/8   | 033-72259-2  | 053-71411-41     | 035-72735-7         | 033-72259-24       |                |
| 2562     | .812–1.000      | 1½" | 1⅞"      | 1                  | 2½   | 2½               | 5/8   | 033-72259-3  | 053-71411-41     | 035-72735-7         | 053-71411-48       |                |
| 2563     | 1.000–1.187     | 1½" | 1⅞"      | 1                  | 2½   | 2½               | 5/8   | 053-71411-17 | 053-71411-41     | 035-72735-7         | 053-71411-48       |                |
| 2564     | 1.187–1.375     | 1½" | 1⅞"      | 1                  | 2½   | 2½               | 5/8   | 053-71411-18 | 053-71411-41     | 035-72735-7         | 053-71411-48       |                |
| 2565*    | 1.375–1.625     | 1½" | 1⅞"      | 1                  | 2½   | 2½               | 5/8   | 053-71411-65 | 053-71411-42     | 035-72735-8         | 033-72259-25       |                |
| 2573     | 1.125–1.375     | 2"  | 1⅞"      | 1                  | 2½   | 2½               | 5/8   | 053-71411-66 | 053-71411-42     | 035-72735-8         | 053-71411-49       |                |
| 2574     | 1.375–1.625     | 2"  | 1⅞"      | 1                  | 2½   | 2½               | 5/8   | 053-71411-65 | 053-71411-42     | 035-72735-8         | 053-71411-49       |                |
| 2575     | 1.625–1.875     | 2"  | 1⅞"      | 1                  | 2½   | 3½               | 5/8   | 053-71411-67 | 053-71411-42     | 035-72735-8         | 053-71411-49       |                |
| 2576*    | 1.750–1.965     | 2"  | 1⅞"      | 1                  | 3½   | 3½               | 5/8   | 033-72259-5  | 033-72259-17     | 035-72735-9         | 033-72259-26       |                |
| 2577*    | 1.937–2.187     | 2"  | 1⅞"      | 1                  | 3½   | 3½               | 5/8   | 033-72259-6  | 033-72259-17     | 035-72735-9         | 033-72259-26       |                |
| 2584     | 1.750–1.965     | 2½" | 2"       | 1                  | 3½   | 3¾               | 1½    | 033-72259-5  | 033-72259-17     | 035-72259-14        | 033-72259-27       |                |
| 2585     | 1.937–2.187     | 2½" | 2"       | 1                  | 3½   | 3¾               | 1½    | 033-72259-6  | 033-72259-18     | 033-72259-14        | 033-72259-27       |                |
| 2586*    | 2.156–2.360     | 2½" | 2⅝"      | 1                  | 3½   | 4¼               | 1½    | 033-72259-7  | 033-72259-19     | 033-72259-15        | 033-72259-28       |                |
| 2587*    | 2.350–2.565     | 2½" | 2⅝"      | 1                  | 3½   | 4¼               | 1½    | 033-72259-8  | 033-72259-19     | 033-72259-15        | 033-72259-28       |                |
| 2592     | 2.156–2.360     | 3"  | 2⅝"      | 1                  | 3½   | 4¼               | 1½    | 033-72259-7  | 033-72259-19     | 033-72259-15        | 033-72259-29       |                |
| 2593     | 2.350–2.565     | 3"  | 2⅝"      | 1                  | 3½   | 4¼               | 1½    | 033-72259-8  | 033-72259-19     | 033-72259-15        | 033-72259-29       |                |
| 2594     | 2.535–2.750     | 3"  | 2⅝"      | 1                  | 3½   | 4¼               | 1½    | 033-72259-9  | 033-72259-19     | 033-72259-15        | 033-72259-29       |                |
| 2595*    | 2.735–2.985     | 3"  | 2⅝"      | 1                  | 4⅞   | 4⅞               | 1½    | 033-72259-10 | 033-72259-20     | 033-72259-16        | 033-72259-30       |                |
| 2596*    | 2.970–3.220     | 3"  | 2⅝"      | 1                  | 4⅞   | 4⅞               | 1½    | 033-72259-11 | 033-72259-20     | 033-72259-16        | 033-72259-30       |                |

## Metallic Liquidtight Cord and Cable Connectors

### Liquidtight Strain-Relief Connectors — 45°

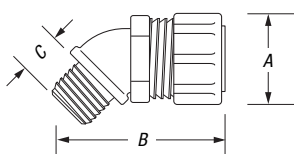

For wire mesh grips, refer to page E-142.

| CAT. NO. | CABLE-SIZE<br>MIN.-MAX. (IN.) | HUB SIZE | DIMENSIONS (IN.) |         |        | THROAT<br>DIA. |
|----------|-------------------------------|----------|------------------|---------|--------|----------------|
|          |                               |          | A                | B       | C      |                |
| 2200     | .125-.250                     | 1/2"     | 1 1/8            | 1 1/32  | 9/16   | 37/64          |
| 2201     | .250-.375                     | 1/2"     | 1 1/8            | 1 1/32  | 9/16   | 37/64          |
| 2202     | .375-.500                     | 1/2"     | 1 1/8            | 1 1/32  | 9/16   | 37/64          |
| 2203     | .450-.560                     | 1/2"     | 1 1/8            | 1 1/32  | 9/16   | 37/64          |
| 2204*    | .500-.625                     | 1/2"     | 1 3/8            | 1 13/32 | 9/16   | 37/64          |
| 2205*    | .625-.750                     | 1/2"     | 1 3/8            | 1 13/32 | 9/16   | 37/64          |
| 2206     | .125-.250                     | 3/4"     | 1 3/8            | 1 13/32 | 5/8    | 25/32          |
| 2207     | .250-.375                     | 3/4"     | 1 3/8            | 1 13/32 | 5/8    | 25/32          |
| 2208     | .375-.500                     | 3/4"     | 1 3/8            | 1 13/32 | 5/8    | 25/32          |
| 2209     | .500-.625                     | 3/4"     | 1 3/8            | 1 13/32 | 5/8    | 25/32          |
| 2210     | .625-.750                     | 3/4"     | 1 3/8            | 1 13/32 | 5/8    | 25/32          |
| 2211*    | .750-.880                     | 3/4"     | 1 11/16          | 1 1/2   | 1 1/2  | 3/4            |
| 2213     | .375-.500                     | 1"       | 1 3/8            | 1 1/2   | 25/32  | 15/16          |
| 2214     | .500-.625                     | 1"       | 1 3/8            | 1 1/2   | 25/32  | 15/16          |
| 2215     | .625-.750                     | 1"       | 1 3/8            | 1 1/2   | 25/32  | 15/16          |
| 2216     | .750-.875                     | 1"       | 1 11/16          | 1 15/32 | 25/32  | 15/16          |
| 2217*    | .875-.985                     | 1"       | 1 11/16          | 1 15/32 | 25/32  | 15/16          |
| 2218*    | .880-1.065                    | 1"       | 2 1/16           | 1 31/32 | 25/32  | 15/16          |
| 2219*    | 1.065-1.205                   | 1"       | 2 1/16           | 1 31/32 | 25/32  | 15/16          |
| 2220*    | .880-1.065                    | 1 1/4"   | 2 1/16           | 1 29/32 | 1 1/16 | 15/16          |
| 2221*    | 1.065-1.205                   | 1 1/4"   | 2 1/16           | 1 29/32 | 1 1/16 | 15/16          |
| 2222*    | 1.187-1.375                   | 1 1/4"   | 2 1/16           | 2 1/4   | 1 1/16 | 1 21/64        |
| 2223*    | 1.375-1.485                   | 1 1/4"   | 2 1/16           | 2 1/4   | 1 1/16 | 1 21/64        |

### Liquidtight Strain-Relief Connectors — 90°

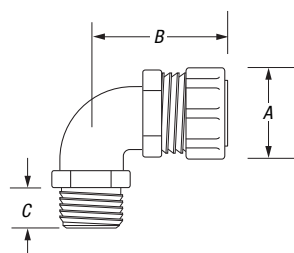

| CAT. NO. | CABLE-SIZE<br>MIN.-MAX. (IN.) | HUB SIZE | DIMENSIONS (IN.) |         |        | THROAT<br>DIA. |
|----------|-------------------------------|----------|------------------|---------|--------|----------------|
|          |                               |          | A                | B       | C      |                |
| 2268     | .250-.375                     | 1/2"     | 1 1/8            | 1 23/32 | 5/8    | 19/32          |
| 2269     | .375-.500                     | 1/2"     | 1 1/8            | 1 23/32 | 5/8    | 19/32          |
| 2270     | .450-.560                     | 1/2"     | 1 1/8            | 1 23/32 | 5/8    | 19/32          |
| 2250*    | .500-.625                     | 1/2"     | 1 3/8            | 1 11/16 | 9/16   | 39/64          |
| 2251*    | .625-.750                     | 1/2"     | 1 3/8            | 1 11/16 | 9/16   | 39/64          |
| 2252     | .125-.250                     | 3/4"     | 1 3/8            | 1 3/4   | 1/2    | 25/32          |
| 2271     | .250-.375                     | 3/4"     | 1 3/8            | 1 3/4   | 1/2    | 25/32          |
| 2272     | .375-.500                     | 3/4"     | 1 3/8            | 1 3/4   | 1/2    | 25/32          |
| 2273     | .500-.625                     | 3/4"     | 1 3/8            | 1 3/4   | 1/2    | 25/32          |
| 2274*    | .620-.750                     | 3/4"     | 1 3/8            | 1 3/4   | 1/2    | 25/32          |
| 2253*    | .750-.880                     | 3/4"     | 1 11/16          | 1 31/32 | 9/16   | 25/32          |
| 2254     | .375-.500                     | 1"       | 1 3/8            | 2       | 25/32  | 1              |
| 2255     | .500-.625                     | 1"       | 1 3/8            | 2       | 25/32  | 1              |
| 2256*    | .625-.750                     | 1"       | 1 3/8            | 2       | 25/32  | 1              |
| 2275     | .750-.875                     | 1"       | 1 11/16          | 2       | 5/8    | 1              |
| 2276     | .875-.985                     | 1"       | 1 11/16          | 2       | 5/8    | 1              |
| 2257*    | .880-1.065                    | 1"       | 2 1/16           | 2 21/32 | 25/32  | 1 5/16         |
| 2258*    | 1.065-1.205                   | 1"       | 2 1/16           | 2 21/32 | 25/32  | 1 5/16         |
| 2277     | .880-1.065                    | 1 1/4"   | 2 1/16           | 2 7/8   | 1 1/16 | 1 5/16         |
| 2278     | 1.065-1.205                   | 1 1/4"   | 2 1/16           | 2 7/8   | 1 1/16 | 1 5/16         |
| 2279*    | 1.187-1.375                   | 1 1/4"   | 2 5/16           | 2 3/16  | 1 3/16 | 1 11/32        |
| 2280*    | 1.375-1.485                   | 1 1/4"   | 2 5/16           | 2 19/16 | 1 3/16 | 1 11/32        |
| 2281     | .812-1.000                    | 1 1/2"   | 2 5/16           | 2 7/8   | 1 3/16 | 1 15/32        |
| 2282     | 1.000-1.187                   | 1 1/2"   | 2 5/16           | 2 7/8   | 1 3/16 | 1 15/32        |
| 2283*    | 1.187-1.375                   | 1 1/2"   | 2 5/16           | 2 7/8   | 1 3/16 | 1 15/32        |
| 2284     | 1.125-1.375                   | 2"       | 2 25/32          | 3 1/4   | 2 7/32 | 1 31/32        |
| 2285     | 1.375-1.625                   | 2"       | 2 25/32          | 3 1/4   | 2 7/32 | 1 31/32        |
| 2286     | 1.625-1.875                   | 2"       | 2 25/32          | 3 1/4   | 2 7/32 | 1 31/32        |

UL Listed as liquidtight strain relief and outlet bushing.  
CSA certified watertight.

UL File No. E 13938

CSA File No. 589 & 4484

\* UL not applicable.

\* Remove sufficient outer covering of cable to permit conductors to pass through connector body.

Complies with JIC standards.

Temperature rating 105° C.

Suitable for hazardous locations use where general-purpose equipment is specifically permitted per NEC®.

## Metallic Liquidtight Cord and Cable Connectors

### CHASE® Liquidtight Cord Connectors

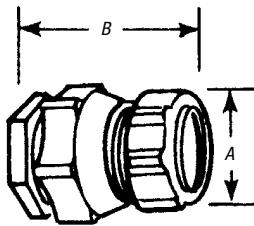

| CAT. NO. | CABLE SIZE RANGE SIZE (IN.) | THROAT DIA. | CORD RANGE | DIMENSIONS (IN.) |          |
|----------|-----------------------------|-------------|------------|------------------|----------|
|          |                             |             |            | A                | B        |
| 2631     | .125-.250                   | 1/2"        | 9/16"      | 1 1/16"          | 1 5/8"   |
| 2632     | .250-.375                   | 1/2"        | 9/16"      | 1 1/16"          | 1 5/8"   |
| 2633     | .375-.500                   | 1/2"        | 9/16"      | 1 1/16"          | 1 5/8"   |
| 2634     | .450-.560                   | 1/2"        | 9/16"      | 1 1/16"          | 1 5/8"   |
| 2637     | .125-.250                   | 3/4"        | 25/32"     | 1 5/16"          | 1 3/4"   |
| 2638     | .250-.375                   | 3/4"        | 25/32"     | 1 5/16"          | 1 3/4"   |
| 2639     | .375-.500                   | 3/4"        | 25/32"     | 1 5/16"          | 1 3/4"   |
| 2640     | .500-.625                   | 3/4"        | 25/32"     | 1 5/16"          | 1 3/4"   |
| 2641     | .625-.750                   | 3/4"        | 25/32"     | 1 5/16"          | 1 3/4"   |
| 2646     | .500-.625                   | 1"          | 1"         | 1 5/8"           | 1 13/16" |
| 2647     | .625-.750                   | 1"          | 1"         | 1 5/8"           | 1 13/16" |
| 2648     | .750-.880                   | 1"          | 1"         | 1 5/8"           | 1 13/16" |

Suitable for hazardous locations use in Class I, Div. 2; Class II, Div. 1 and 2; Class III, Div. 1 and 2, where general-purpose equipment is specifically permitted per NEC® Section 500-2(a).

Complete with O-Ring seal and nylon insulated throat and neoprene bushing.

UL Listed as liquidtight strain relief and outlet bushing.  
CSA certified watertight.

Temperature Rating: 105° C UL File No. E 13938

CSA File No. 589. CHASE® Liquidtight Cord Connectors are ideal for installation where space is limited inside the enclosure.

Conduit & Fittings — T&B® Cord & Cable Fittings

### Multi-Hole Flexible Cord and Cable Connectors



| CAT. NO. | HUB SIZE (IN.) | DIA. NO. | CORD DIA. (IN.) |
|----------|----------------|----------|-----------------|
| 2520-2   | 1/2"           | 2        | .220            |
| 2530-2   | 3/4"           | 2        | .220            |
| 2531-2   | 3/4"           | 2        | .260            |
| 2531-3   | 3/4"           | 3        | .260            |
| 2541-2   | 1"             | 2        | .300            |
| 2542-2   | 1"             | 2        | .375            |
| 2540-3   | 1"             | 3        | .225            |
| 2541-3   | 1"             | 3        | .300            |
| 2540-4   | 1"             | 4        | .220            |
| 2555-2   | 1 1/4"         | 2        | .500            |

**Note:** Range of cord dia. ±.010.

In many applications, you have only room for one fitting but you need to run two cables (for example, proximity switches). Now you can provide strain relief and liquidtight protection with T&B's new multi-hole liquidtight strain relief connectors. With the ever-increasing number of signal cables, now you have a solution to the problem of how to strain relieve multiple cables in one fitting.

## Metallic Liquidtight Cord and Cable Connectors

### The T&B WMG-PC Series Wire Mesh Grips for Portable Cord

T&B Wire Mesh grips are ordered separately and fit with your existing inventory of Ranger® connectors and liquidtight strain-relief connectors. There's no need to duplicate inventory.

#### Application

- Provides high gripping strength for adequate cable support and strain relief without damage to the cable sheath
- Compression of a tapered neoprene bushing ensures the watertight integrity of the fittings
- To meet National Electrical Code (NEC®) requirements for electrical installations in hazardous atmospheres, a sealing fitting may be required in conjunction with the cable and cord fitting

#### Cord & Cable Type

- S, SO, SV, ST, STD, SJ, SJO, SJT, SJTO, SVD

#### Features

- Prevents severe cord bends and pullouts
- Used in aluminum and/or steel fittings

#### How to select proper wiremesh grip:

1. Determine O.D. of portable cord, e.g., .200
2. Determine size of knockout or threaded hub, e.g. ½"
3. Select Cat. No. of strain relief connector, e.g., 2520, 2920AL.
4. Match up O.D. with grip range and strain relief to determine Cat. No. of Wiremesh Grip (e.g., .200 + 2520 = WMP-PC1)



2920 Series



2920AL Series



2516 Series



Now Includes Ranger® Series

#### Materials

Wiremesh made of stainless steel.  
Retaining rings made of aluminum

#### Environment Classification

Ordinary locations

#### Range

.187 – 3.220



| CAT. NO.  | GRIP RANGE  | STRAIN-RELIEF CONNECTOR |                  |           |               |           |               |                  |           |  |
|-----------|-------------|-------------------------|------------------|-----------|---------------|-----------|---------------|------------------|-----------|--|
|           |             | STRAIGHT                |                  |           | 45°           |           |               | 90°              |           |  |
|           |             | RANGER® STEEL           | RANGER® ALUMINUM | T&B STEEL | RANGER® STEEL | T&B STEEL | RANGER® STEEL | RANGER® ALUMINUM | T&B STEEL |  |
| WMG-PC1   | .187-.250   | 2920                    | 2920AL           | 2520      | 4920          | 2200      | 4960          | 4960AL           | 2267      |  |
| WMG-PC2   | .250-.375   | 2920                    | 2920AL           | 2521      | 4920          | 2201      | 4960          | 4960AL           | 2268      |  |
| WMG-PC3   | .375-.500   | 2921                    | 2921AL           | 2522      | 4921          | 2202      | 4961          | 4961AL           | 2269      |  |
| WMG-PC4   | .500-.625   | 2922                    | 2922AL           | 2524      | 4922          | 2204      | 4962          | 4962AL           | 2250      |  |
|           |             | 2932                    | 2932AL           | 2534      | 4932          | 2209      | 4972          | 4972AL           | 2273      |  |
|           |             | 2941                    | 2941AL           | 2544      | 4941          | 2214      | 4981          | 4981AL           | 2255      |  |
| WMG-PC5   | .625-.750   | 2922                    | 2922AL           | 2525      | 4922          | 2205      | 4962          | 4962AL           | 2251      |  |
|           |             | 2932                    | 2932AL           | 2535      | 4932          | 2210      | 4972          | 4972AL           | 2274      |  |
|           |             | 2941                    | 2941AL           | 2545      | 4941          | 2215      | 4981          | 4981AL           | 2256      |  |
| WMG-PC6   | .187-.250   | 2930                    | 2930AL           | 2530      | 4930          | 2206      | 4970          | 4970AL           | 2252      |  |
| WMG-PC7   | .250-.375   | 2930                    | 2930AL           | 2531      | 4930          | 2207      | 4970          | 4970AL           | 2271      |  |
| WMG-PC8   | .375-.500   | —                       | —                | 2541      | —             | —         | —             | —                | —         |  |
|           |             | 2931                    | 2931AL           | 2532      | 4931          | 2208      | 4961          | 4961AL           | 2272      |  |
|           |             | 2940                    | 2940AL           | 2542      | 4940          | 2213      | 4980          | 4980AL           | 2254      |  |
| WMG-PC9   | .750-.875   | —                       | —                | 2536      | —             | 2211      | —             | —                | 2253      |  |
|           |             | 2942                    | 2942AL           | 2546      | 4942          | 2216      | 4982          | 4982AL           | 2275      |  |
|           |             | —                       | —                | 2547      | —             | 2217      | —             | —                | 2276      |  |
| WMG-PC10  | .875-1.000  | —                       | —                | 2548      | —             | 2218      | —             | —                | 2257      |  |
| WMG-PC11  | .875-1.000  | —                       | —                | 2558      | —             | 2220      | —             | —                | 2277      |  |
| WMG-PC12  | 1.000-1.125 | —                       | —                | 2548      | —             | 2218      | —             | —                | 2257      |  |
|           |             | —                       | —                | 2558      | —             | 2220      | —             | —                | 2277      |  |
|           |             | —                       | —                | 2549      | —             | 2219      | —             | —                | 2258      |  |
| WMG-PC13  | 1.125-1.250 | —                       | —                | 2559      | —             | 2221      | —             | —                | 2278      |  |
|           |             | —                       | —                | 2549      | —             | —         | 2258          | 2258             | 2219      |  |
|           |             | —                       | —                | 2559      | —             | 2221      | —             | —                | 2278      |  |
| WMG-PC14  | 1.125-1.250 | —                       | —                | 2556      | —             | —         | 2279          | 2279             | 2222      |  |
|           |             | —                       | —                | 2563      | —             | —         | —             | —                | 2282      |  |
|           |             | —                       | —                | 2564      | —             | —         | —             | —                | 2283      |  |
| WMG-PC15  | 1.250-1.375 | —                       | —                | —         | —             | 2222      | —             | —                | 2256      |  |
| WMG-PC16* | 1.375-1.500 | —                       | —                | 2564      | —             | —         | —             | —                | 2283      |  |
|           |             | —                       | —                | 2557      | —             | 2223      | —             | —                | 2280      |  |
|           |             | —                       | —                | 2573      | —             | —         | —             | —                | 2284      |  |
| WMG-PC17* | 1.125-1.250 | —                       | —                | 2573      | —             | —         | —             | —                | 2284      |  |
| WMG-PC18* | 1.250-1.375 | —                       | —                | 2573      | —             | —         | —             | —                | 2284      |  |
| WMG-PC19* | 1.375-1.500 | —                       | —                | 2565      | —             | —         | —             | —                | 2285      |  |
|           |             | —                       | —                | 2574      | —             | —         | —             | —                | —         |  |
|           |             | —                       | —                | 2574      | —             | —         | —             | —                | —         |  |
| WMG-PC20* | 1.500-1.625 | —                       | —                | 2565      | —             | —         | —             | —                | 2285      |  |
|           |             | —                       | —                | 2574      | —             | —         | —             | —                | —         |  |
|           |             | —                       | —                | 2574      | —             | —         | —             | —                | —         |  |
| WMG-PC21* | 1.625-1.750 | —                       | —                | 2575      | —             | —         | —             | —                | 2286      |  |
| WMG-PC22* | 1.750-1.875 | —                       | —                | 2575      | —             | —         | —             | —                | 2286      |  |

\*Replacement Gland Nut supplied with these catalog numbers only.

## Non-Metallic Liquidtight Cord Connectors

### Non-Metallic Liquidtight Flexible Cord Connectors — Black Beauty® Series

#### Application

- A liquidtight connector to connect flexible cord to a box or enclosure and provide adequate strain relief

#### Features

- Taper Thread hub seals in female hub (A)
- Neoprene bushing provides liquidtight installation (B)
- Hand tightens — no tools needed for assembly
- Segmented chuck provides high mechanical pullout performance — will not cut or damage cord jacket (C)
- Corrosion- and weather-resistant plastic is excellent for outdoor/indoor use
- Plastic parts improve dielectric strength and provide insulated throat (D)
- Wide range — reduces inventories

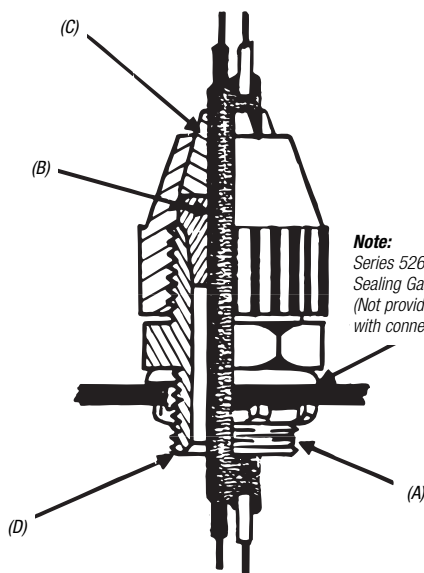

Typical Installation

**Note:**  
Series 5262  
Sealing Gasket  
(Not provided  
with connector)

#### Standard Material

Body, Gland & Segmented Chuck ..... Weather-stabilized thermoplastic rated for -34° C (-29° F) to 105° C (221° F) application  
Bushing..... Neoprene

#### Standard Finish

All parts as molded

#### Range

.250 Outside Diameter to 1.020 Outside Diameter .....Type S,  
SO, SV, ST, STO, SJ, SJO, SJT, SJTO, SVTO, SVO, SVT  
Flexible Cords & Cables

#### Listings/Compliances

UL (UL File No. E-23018)  
CSA LR-2884, LR-4484  
UL 514B  
CSA C22.2 No. 18  
NFPA 70  
Federal Standard H-28 (Threads)



2672 Series



2682 Series

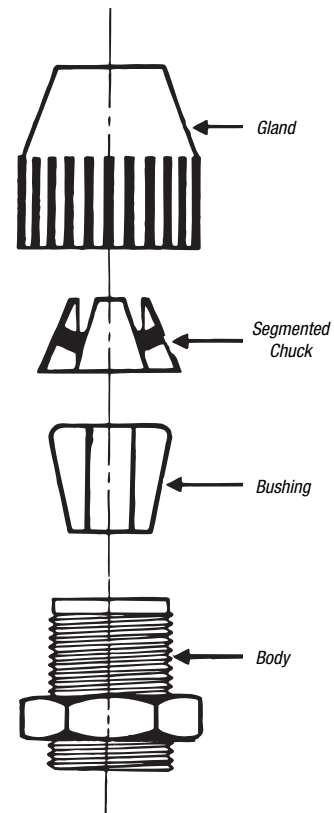

2672 Series



## Non-Metallic Liquidtight Cord Connectors

Rugged, weather-stabilized nylon construction!

### Black Beauty® Non-Metallic Liquidtight Strain-Relief Connector — Straight

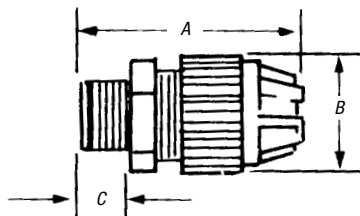

- UL 94-V2 flammability rated
- Temperature rating: -34° C to +105° C
- Meets Coast Guard CG293



| CAT. NO. | TRADE OR HUB SIZE | THROAT DIA. (IN.) | CORD RANGE (IN.) | DIMENSIONS (IN.) |      |     |
|----------|-------------------|-------------------|------------------|------------------|------|-----|
|          |                   |                   |                  | A                | B    | C   |
| 2671     | 3/8"              | .33               | .125-.275        | 2.0              | .90  | .46 |
| 2690     | 1/2"              | .33               | .125-.275        | 2.3              | .90  | .60 |
| 2672     | 1/2"              | .55               | .250-.400        | 2.6              | 1.27 | .60 |
| 2673*    | 1/2"              | .55               | .400-.560        | 2.6              | 1.27 | .60 |
| 2691*    | 1/2"              | .54               | .560-.690        | 3.0              | 1.57 | .60 |
| 2692*    | 1/2"              | .54               | .660-.780        | 3.0              | 1.57 | .60 |
| 2693     | 3/4"              | .55               | .250-.400        | 2.7              | 1.27 | .62 |
| 2694*    | 3/4"              | .55               | .400-.560        | 2.7              | 1.27 | .62 |
| 2674     | 3/4"              | .79               | .560-.690        | 3.0              | 1.57 | .62 |
| 2675     | 3/4"              | .79               | .660-.780        | 3.0              | 1.57 | .62 |
| 2696*    | 3/4"              | .76               | .770-.895        | 3.2              | 1.89 | .62 |
| 2676     | 1"                | .98               | .660-.780        | 3.3              | 1.89 | .77 |
| 2677     | 1"                | .98               | .770-.895        | 3.3              | 1.89 | .77 |
| 2678*    | 1"                | .98               | .870-1.020       | 3.3              | 1.89 | .77 |
| 2699     | 1"                | .98               | .890-1.090       | 4.2              | 2.58 | .77 |
| 2702     | 1 1/4"            | 1.25              | .890-1.090       | 4.2              | 2.58 | .80 |
| 2703     | 1 1/4"            | 1.25              | 1.080-1.280      | 4.0              | 2.58 | .80 |
| 2704     | 1 1/4"            | 1.25              | 1.270-1.470      | 4.0              | 2.58 | .80 |
| 2705-TB  | 1 1/2"            | 1.47              | .890-1.150       | 4.2              | 2.95 | .82 |
| 2706     | 1 1/2"            | 1.47              | 1.140-1.400      | 4.3              | 2.95 | .82 |
| 2707     | 1 1/2"            | 1.47              | 1.390-1.650      | 4.3              | 2.95 | .82 |
| 2708     | 2"                | 1.89              | 1.190-1.530      | 5.1              | 3.50 | .84 |
| 2709     | 2"                | 1.89              | 1.520-1.860      | 4.9              | 3.50 | .84 |
| 2710*    | 2"                | 1.89              | 1.850-2.190      | 4.9              | 3.50 | .84 |

\*Remove sufficient outer covering of cable to permit conductors to pass thru connector body. All items shown on this page are suitable for use in hazardous location where general-purpose equipment is specifically permitted by the NEC®. Class I, Div. 2. Class II, Div. 1 & 2. Class III, Div. 1 & 2.

UL File No. E 13938  
CSA File No. 52391

## 90° angle with a standard-size body!

### Black Beauty® Non-Metallic Liquidtight Strain-Relief Connector — 90° Elbow

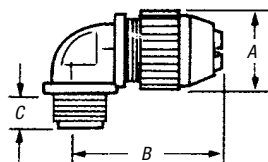

- Weather-stabilized nylon construction
- UL 94-V2 flammability rated
- Temperature rating: -34° C to +105° C
- Meets Coast Guard CG293

| CAT. NO. | TRADE OR HUB SIZE | THROAT DIA. (IN.) | CORD RANGE (IN.) | DIMENSIONS (IN.) |        |      |
|----------|-------------------|-------------------|------------------|------------------|--------|------|
|          |                   |                   |                  | A                | B      | C    |
| 2680     | 3/8"              | .33               | .125-.275        | 2 9/32           | 1 1/4  | .460 |
| 2681     | 1/2"              | .55               | .250-.400        | —                | —      | —    |
| 2682*    | 1/2"              | .55               | .400-.560        | —                | —      | —    |
| 2683     | 3/4"              | .78               | .560-.690        | —                | —      | —    |
| 2684     | 3/4"              | .78               | .660-.780        | —                | —      | —    |
| 2688     | 1"                | .98               | .560-.690        | 1 27/32          | 3/4    | .770 |
| 2685     | 1"                | .98               | .660-.780        | 1 27/32          | 3/4    | .770 |
| 2686     | 1"                | .98               | .770-.895        | 1 27/32          | 3 1/16 | .770 |
| 2687*    | 1"                | .98               | .870-1.020       | 1 27/32          | 3      | .770 |

\*Remove sufficient outer covering of cable to permit conductors to pass thru connector body. 90° angle, standard size body. All items shown on this page are suitable for use in hazardous locations where general-purpose equipment is specifically permitted by the NEC. Class I, Div. 2. Class II, Div. 1 & 2. Class III, Div. 1 & 2.

UL File No. E 13938  
CSA File No. 52391

## Non-Metallic Liquidtight Cord Connectors

Low-profile cable gland perfect for tight spots.

### Non-Metallic Cable Glands

T&B Nylon Cable Glands have a sturdy cable sealing mechanism that results in superior strain relief. The compact size ensures quick and easy installation in cramped spaces. The non-metallic construction provides excellent corrosion, chemical and impact resistance. The glands have long threads and locknuts are available.



- Halogen free
- Flame-retardant UL94V-0
- Rated IP68 5 BAR, suitable for NEMA 4 enclosures
- UL® Listed\*, CSA Certified for certain ranges of cable
- Working temperatures: -30° C (-22° F) to 80° C (176° F)  
Continuous, +150° C (276° F) Intermittent
- Meets VDE ratings

\* Material not UV resistant. Sturdy Nylon 6 for strong, lightweight construction. Gray color shown; also available in black.



| CAT. NO.<br>FITTINGS      | TRADE<br>SIZE | COLOR | CORD RANGE |         | LENGTH OF THREAD |      | USE T&B<br>LOCKNUT CAT. NO. | UNIT<br>PKG. | STD.<br>PKG. |
|---------------------------|---------------|-------|------------|---------|------------------|------|-----------------------------|--------------|--------------|
|                           |               |       | IN.        | MM      | IN.              | MM   |                             |              |              |
| <b>NPT Threads</b>        |               |       |            |         |                  |      |                             |              |              |
| CC-NPT38-B                | 3/8"          | Black | .197-.394  | 5-10mm  | .590             | 15mm | —                           | 50           | 250          |
| CC-NPT38-G                | 3/8"          | Gray  | .197-.394  | 5-10mm  | .590             | 15mm | —                           | 50           | 250          |
| CC-NPT12-B                | 1/2"          | Black | .394-.551  | 10-14mm | .590             | 15mm | LN501                       | 50           | 250          |
| CC-NPT12-G                | 1/2"          | Gray  | .394-.551  | 10-14mm | .590             | 15mm | LN501                       | 50           | 250          |
| CC-NPT34-B                | 3/4"          | Black | .512-.709  | 13-18mm | .590             | 15mm | LN502                       | 25           | 100          |
| CC-NPT34-G                | 3/4"          | Gray  | .512-.709  | 13-18mm | .590             | 15mm | LN502                       | 25           | 100          |
| CC-NPT1-B                 | 1"            | Black | .709-.984  | 18-25mm | .709             | 18mm | LN503                       | 20           | 100          |
| CC-NPT1-G                 | 1"            | Gray  | .709-.984  | 18-25mm | .709             | 18mm | LN503                       | 20           | 100          |
| <b>ISO/Metric Threads</b> |               |       |            |         |                  |      |                             |              |              |
| CC-ISO16-G                | 16"           | Gray  | .197-.394  | 5-10mm  | .394             | 10mm | LN-ISO16-G                  | 50           | 200          |
| CC-ISO20-G                | 20"           | Gray  | .236-.473  | 6-12mm  | .590             | 15mm | LN-ISO20-G                  | 50           | 200          |
| CC-ISO25-G                | 25"           | Gray  | .512-.709  | 13-18mm | .590             | 15mm | LN-ISO25-G                  | 25           | 100          |
| CC-ISO32-G                | 32"           | Gray  | .709-.984  | 16-25mm | .590             | 15mm | LN-ISO32-G                  | 20           | 100          |
| CC-ISO40-G                | 40"           | Gray  | .748-1.10  | 22-32mm | .709             | 18mm | LN-ISO40-G                  | 15           | 75           |
| <b>PG Threads</b>         |               |       |            |         |                  |      |                             |              |              |
| CC-PG7-G                  | 7"            | Gray  | .118-.256  | 3-6.5mm | .315             | 8mm  | LN-PG7-G                    | 50           | 200          |
| CC-PG9-G                  | 9"            | Gray  | .157-.315  | 4-8mm   | .315             | 8mm  | LN-PG9-G                    | 50           | 200          |
| CC-PG11-G                 | 11"           | Gray  | .197-.394  | 5-10mm  | .315             | 8mm  | LN-PG11-G                   | 25           | 100          |
| CC-PG135-G                | 13 1/2"       | Gray  | .236-.473  | 6-12mm  | .354             | 9mm  | LN-PG135-G                  | 25           | 100          |
| CC-PG16-G                 | 16"           | Gray  | .394-.551  | 10-14mm | .394             | 10mm | LN-PG16-G                   | 25           | 100          |
| CC-PG21-G                 | 21"           | Gray  | .512-.709  | 13-18mm | .433             | 11mm | LN-PG21-G                   | 10           | 50           |
| CC-PG29-G                 | 29"           | Gray  | .709-.984  | 18-25mm | .433             | 11mm | LN-PG29-G                   | 10           | 50           |
| CC-PG36-G                 | 36"           | Gray  | .867-1.26  | 22-32mm | .512             | 13mm | LN-PG36-G                   | 10           | 50           |

Listed under UL file E13938, control #137B. NPT and PG threaded Cable Glands are UL Listed; ISO/Metric Threaded Cable Glands are not UL Listed.

## Non-Metallic Liquidtight Cord Connectors

### Non-Metallic Cable/Cord Fitting with Integral Strain-Relief

Thomas & Betts is pleased to announce the new non-metallic spiral cable/cord connector. T&B spiral cable/cord connectors are ideal in environments where maximum protection is needed against conductor fatigue caused by flexing cables.

- Strain-relief is integral to the fitting, saving time and costs of additional parts for cable/cord installations
- UL Listed
- Rated IP68, suitable for NEMA 4 enclosures
- Meets VDE ratings for European applications

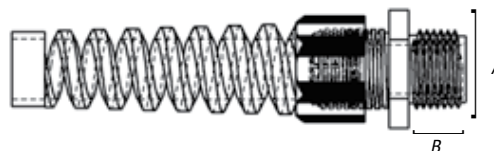

#### Specifications

|                             |   |
|-----------------------------|---|
| Materials .....             | Polyamide 6 (Body, Cap),<br>Neoprene (Sealing Ring) |
| Colors Available .....      | Black, Gray   |
| Protection Class .....      | IP68, 5 Bar   |
| Temperature Range .....     | -30° C to 80° C permanent<br>(-22° F to 176° F)     |
| Operating Temperature ..... | Up to +150° C (+276° F)<br>continuous               |

Please contact your Thomas & Betts sales representative regarding our custom grommet offering.

| CAT. NO.   | TRADE SIZE | MIN. CABLE RANGE | MAX. CABLE RANGE | USE T&B LOCKNUT CAT. NO. | COLOR | DIMENSIONS (IN.) |      | STD. PKG. QTY. |
|------------|------------|------------------|------------------|--------------------------|-------|------------------|------|----------------|
|            |            |                  |                  |                          |       | A                | B    |                |
| SP-NPT38-G | 3/8"       | .197             | .394             | —                        | Gray  | .866             | .590 | 25             |
| SP-NPT38-B | 3/8"       | .197             | .394             | —                        | Black | .866             | .590 | 25             |
| SP-NPT12-G | 1/2"       | .394             | .551             | LN501                    | Gray  | 1.062            | .590 | 25             |
| SP-NPT12-B | 1/2"       | .394             | .551             | LN501                    | Black | 1.062            | .590 | 25             |
| SP-NPT34-G | 3/4"       | .512             | .709             | LN502                    | Gray  | 1.299            | .590 | 25             |
| SP-NPT34-B | 3/4"       | .512             | .709             | LN502                    | Black | 1.299            | .590 | 25             |

## Space and labor-saving cord fittings for panels.

### Multi-Hole Cord Grip Connectors

- Ideal in limited-space environments where multiple cables run into an enclosure
- Small cables such as instrumentation wires, proximity device wiring and signal cables can run safely into the enclosure
- Rated IP68, suitable for NEMA 4 enclosures
- Easy to assemble, provide good strain relief, offer a wide clamping range and are simple to use



| CAT. NO.    | TRADE SIZE | NUMBER OF OPENINGS | CABLE RANGE |         | BODY LENGTH |         | LENGTH OF THREAD | STD. PKG. QTY. |
|-------------|------------|--------------------|-------------|---------|-------------|---------|------------------|----------------|
|             |            |                    | MINIMUM     | MAXIMUM | MINIMUM     | MAXIMUM |                  |                |
| CC-NPT12-G2 | 1/2"       | 2                  | .190"       | .250"   | 1.051"      | 1.291"  | .590"            | 50             |
| CC-NPT12-G3 | 1/2"       | 3                  | .190"       | .250"   | 1.051"      | 1.291"  | .590"            | 50             |
| CC-NPT34-G2 | 3/4"       | 2                  | .230"       | .290"   | 1.283"      | 1.492"  | .590"            | 25             |
| CC-NPT34-G3 | 3/4"       | 3                  | .230"       | .290"   | 1.283"      | 1.492"  | .590"            | 25             |
| CC-NPT34-G4 | 3/4"       | 4                  | .230"       | .290"   | 1.283"      | 1.492"  | .590"            | 25             |

## Service Entrance Cable Fittings

### Suggested Specifications for Service Entrance Fittings

All service fittings shall be approved for the purpose by a nationally recognized testing laboratory, inspection agency or product evaluation organization.

Where service raceway consists of a rigid metal conduit, intermediate metal conduit, electrical metallic tubing or where service entrance cable is used as service conductors, a suitable raintight service head conforming to Federal Standard W-C-586 shall be provided.

#### Fastening



**Series 4175**  
Pipe Strap (EMT)



**Series 1275/1275AL**  
Pipe Strap (Rigid Metal Conduit & IMC)



**Series 1350/1350AL**  
Pipe Spacer  
(Rigid Metal Conduit IMC & EMT)

Service raceway shall be securely fastened in place to the supporting surface at intervals as specified by the Code using suitable straps and spacers; straps and spacers shall be of malleable iron or steel construction, hot dipped galvanized or electro zinc plated conforming to Canadian Standards Association Standard C22.2 No. 18 and as manufactured by Thomas & Betts; series 1275 or 4175 straps and series 1350 spacers; aluminum straps or spacers such as series 1275AL and series 1350AL may be substituted when installed in environmental conditions that are more than normally corrosive.

#### Threaded Rigid Metal



**Series 1490**  
Entrance ELL

Where threaded rigid metal service raceway enters the building, the raceway shall be equipped with a cast malleable iron/copper-free aluminum entrance ell with a burr-free end stop and taper tapped holes as manufactured by Thomas & Betts, series 1490.



Conduit & Fittings — T&B® Cord & Cable Fittings

#### Grounding & Bonding



**Series 3870**  
Bonding & Grounding Bushing — Insulated

For grounding and bonding of service raceway, end of raceway or the terminating fitting shall be equipped with bonding locknuts and insulated metallic grounding and bonding bushing as required.

Bonding locknuts shall be of hardened steel or malleable iron construction, electro zinc plated, and provided with hardened bonding screws as manufactured by Thomas & Betts, series 106 bonding locknuts.

Insulated metallic grounding and bonding bushing shall be of malleable iron/steel construction, electro zinc plated and assembled with an insulator listed or certified for 150° C/302° F service as manufactured by Thomas & Betts, series 3870.



**Series 106**  
Bonding Locknut

## Service Entrance Cable Fittings

### Suggested Specifications for Service Entrance Fittings *(continued)*

Where service entrance cable is used as overhead service conductors and code requires use of a service head, entrance caps shall be installed; caps shall be cast metal type of suitable ferrous or non-ferrous metal equipped with thermoset insulators and proper knockout openings; caps when installed with proper drip loop must ensure raintight conditions.

At the point where the service cable enters the building, a suitable sill plate shall be provided; sill/wall plate shall be sealed to ensure raintight conditions.



### Terminating Fittings



**Series 2111**  
Service Entrance Cable Connector



**Series 2116**  
Underground Feeder Cable Connector



**Series 3302M**  
Two-Screw Connector (Insulated)

Terminating fittings for service entrance cable (Type SE or USE) or underground feeder and branch — circuit cable (Type UF) in locations where exposed to intermittent or constant moisture or in dry locations and subjected to mechanical strain shall be of watertight strain-relief type as manufactured by Thomas & Betts, series 2111 or 2116; fittings shall be constructed of ferrous or non-ferrous metal and equipped with taper threaded hub, beveled moisture-resistant/oil-resistant synthetic rubber bushing.

In dry locations, nylon-insulated two-screw type fittings of malleable iron/steel construction electro zinc plated inside outside, including threads such as series 3302M manufactured by Thomas & Betts may be substituted.

### Gaskets



**Series 5262**  
Sealing Gasket

Where service entrance cable is terminated into a threadless opening using hub-type fittings, a gasket shall be provided between the outside of box or enclosure and fitting shoulder; gasket shall be of moisture-resistant/oil-resistant synthetic rubber type adequately protected by and permanently retained to a metallic retainer as manufactured by Thomas & Betts, series 5262.

### Supports



**Series 1341**  
Cable Strap

Service entrance cable shall be adequately supported at intervals enumerated in code using cable straps conforming to requirements of Canadian Standards Association Standard CSA 22.2 No. 18; cable straps shall be of malleable iron/steel construction, hot-dipped galvanized or electro zinc plated as manufactured by Thomas & Betts, series 1341.



## Service Entrance Cable Fittings

### Service Entrance Cable Connector

(Type SE/Type Use)

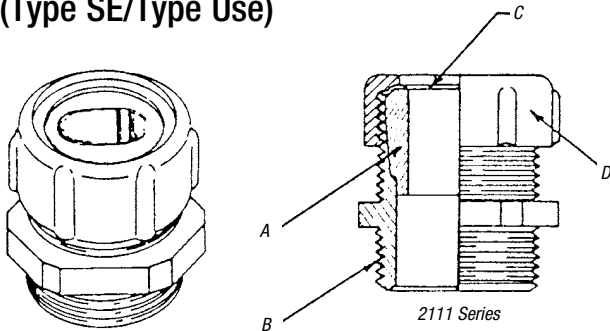

#### Application

- To connect service entrance cables to a meter box or an enclosure

#### Standard Material/Finish

|                      |   |
|----------------------|---|
| Body .....           | Zinc Die Cast/As Cast                       |
| Gland .....          | Steel/Electro Zinc Plated & Chromate Coated |
| Retaining Ring ..... | Stainless Steel/Passivated                  |
| Bushing .....        | Neoprene/As Molded                          |

#### Range

|                              |                                     |
|------------------------------|-------------------------------------|
| Oval (Flat) Cable Size ..... | .260 x .500 thru 1.062 x 1.765      |
| Type USE Cable Size .....    | (3) #12 thru (3) 4/0 AWG Conductors |
| Hub Size .....               | ½" thru 2" NPT (taper pipe threads) |

#### Features

- Neoprene bushing, resists oil and water; grips cable the full length of the bushing, providing adequate strain relief without damaging outer jacket (A)
- Taper threaded body (B)
- Stainless steel retaining ring protects cable jacket against abrasion; reduces installing torque effort (C)
- Rugged ribbed steel gland construction (D)
- Suitable for Type SE & USE Service Entrance Cable

#### Listings/Compliances

|                                   |
|-----------------------------------|
| UL (UL File No. E15170)           |
| CSA (LR589, LR4484)               |
| UL514, NEMA FB1, Federal Standard |
| H-28 (Threads), NFPA70            |

## Underground Feeder Cable Connectors

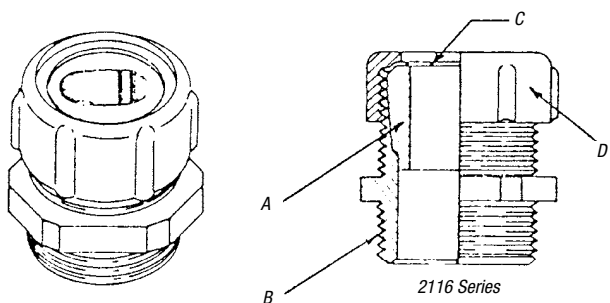

#### Application

- To connect underground feeder cables to a box or an enclosure

#### Standard Material/Finish

|                      |   |
|----------------------|---|
| Body .....           | Zinc Die Cast/As Cast                       |
| Gland .....          | Steel/Electro Zinc Plated & Chromate Coated |
| Retaining Ring ..... | Stainless Steel/Passivated                  |
| Bushing .....        | Neoprene/As Molded                          |

#### Range

|                              |                                       |
|------------------------------|---------------------------------------|
| Oval (Flat) Cable Size ..... | .235 x .500 thru .260 x .740          |
| Hub Size .....               | ½" thru 1" NPT (tapered pipe threads) |

#### Features

- Neoprene bushing resists oil and water; grips cable the full length of the bushing providing adequate strain relief without damaging outer jacket (A)
- Taper threaded body (B)
- Stainless steel retaining ring protects cable jacket against abrasion; reduces installing torque effort (C)
- Rugged ribbed steel gland construction (D)

#### Listings/Compliances

|                                    |
|------------------------------------|
| UL                                 |
| CSA (LR2884)                       |
| UL514B, NEMA FB1, Federal Standard |
| H-28 (Threads), NFPA70             |

## Service Entrance Cable Fittings

Oil- and water-resistant neoprene bushing specially designed for sealing around underground feeder cable!

### Underground Liquidtight Feeder-Cable Fittings

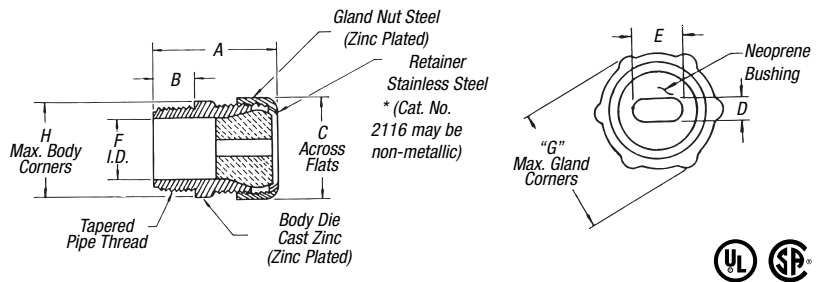

- Stainless steel retaining ring provides bearing surface for glandnut and eliminates cable twist
- Ribbed glandnut tightens easily with wrench to form high-strength connection

| CAT. NO. | HUB SIZE | CABLE OPENING | DIMENSIONS (IN.) |     |       |      |      |      |      |       |       |       |
|----------|----------|---------------|------------------|-----|-------|------|------|------|------|-------|-------|-------|
|          |          |               | A                | B   | C     | D    |      | E    |      | F     | G     | H     |
|          |          |               |                  |     |       | MIN. | MAX. | MIN. | MAX. |       |       |       |
| 2116-TB* | 1/2"     | .235 x .500   | 1 1/16           | 5/8 | 1     | .060 | .235 | .350 | .500 | 3/16  | 1 1/8 | 1 1/8 |
| 2237     | 3/4"     | .230 x .430   | 1 1/16           | 5/8 | 1 1/2 | .080 | .230 | .320 | .430 | 13/16 | 1 1/8 | 1 1/8 |
| 2238     | 3/4"     | .235 x .465   | 1 1/16           | 5/8 | 1 1/2 | .050 | .235 | .340 | .465 | 13/16 | 1 1/8 | 1 1/8 |
| 2239     | 3/4"     | .240 x .685   | 1 1/16           | 5/8 | 1 1/2 | .060 | .240 | .500 | .685 | 13/16 | 1 1/8 | 1 1/8 |

\* Not CSA Certified  
UL File No. E-23017  
CSA File No. 2884

Rocking action of foot allows each strap to accept a wide range of wire sizes!

### Cable Straps

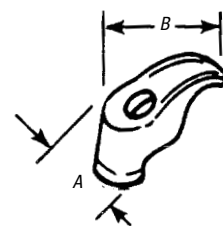
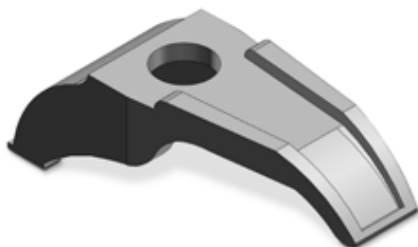

- Hole for 1/4" screw
- Hot-dipped galvanized malleable iron construction

| CAT. NO. | WIRE SIZE    | DIMENSIONS (IN.) |        |
|----------|--------------|------------------|--------|
|          |              | A                | B      |
| 1341-TB  | 2-#10        | 5/8              | 1 1/8  |
| 1344     | 3-#6 or 3-#8 | 5/8              | 1 5/16 |
| 1345*    | 3-#4 or 3-#2 | 13/16            | 1 9/16 |
| 1346     | 3-1/0        | 3/4              | 2 1/16 |
| 1347     | 3-4/0        | 3/4              | 2 5/16 |

\* Steel, hot-dipped galvanized.  
UL not applicable  
CSA Certified

## Service Entrance Cable Fittings

Two-taper design — one slow and one fast — enables connectors to accept varied cable sizes for maximum take-up!

### Watertight Connectors for Oval Cable



- Tapered neoprene bushings resist oil, sunlight and water
- Hex gland and body take same wrench opening
- Stainless-steel slip ring prevents cable from twisting as gland ring is tightened
- Threads on body tapered for water-sealing

| CAT. NO. | HUB SIZE | OVAL CABLE RANGE |               |
|----------|----------|------------------|---------------|
|          |          | MAX.             | MIN.          |
| 2111     | 1/2"     | .420 x .560      | .380 x .520   |
| 2232     | 3/4"     | .385 x .600      | .260 x .500   |
| 2233     | 3/4"     | .500 x .750      | .375 x .625   |
| 2234     | 3/4"     | .555 x .800      | .490 x .675   |
| 2432     | 1"       | .385 x .600      | .260 x .500   |
| 2433     | 1"       | .500 x .750      | .375 x .625   |
| 2434     | 1"       | .555 x .800      | .430 x .675   |
| 2438     | 1"       | .565 x .855      | .440 x .730   |
| 2439     | 1"       | .635 x .975      | .510 x .850   |
| 2442     | 1 1/4"   | .635 x .975      | .510 x .850   |
| 2443     | 1 1/4"   | .640 x 1.050     | .490 x .900   |
| 2446     | 1 1/4"   | .750 x 1.150     | .565 x .965   |
| 2454     | 1 1/2"   | .840 x 1.275     | .655 x 1.090  |
| 2447     | 1 1/2"   | .880 x 1.425     | .695 x 1.240  |
| 2448     | 2"       | .968 x 1.500     | .790 x 1.390  |
| 2449     | 2"       | 1.062 x 1.765    | .850 x 1.550  |
| 2450     | 2"       | 1.820 x 1.190    | 1.700 x 1.050 |

UL File No. E-15170

CSA File No. 589

Note: These may be obsolete and replaced.

## Hand tightens — no tools required!

### Nylon UF-Cable Fittings for Corrosive Environments



- Tapered threaded hub
- Liquidtight and dust tight
- Corrosion- and weather-resistant nylon construction for both outdoor and indoor applications

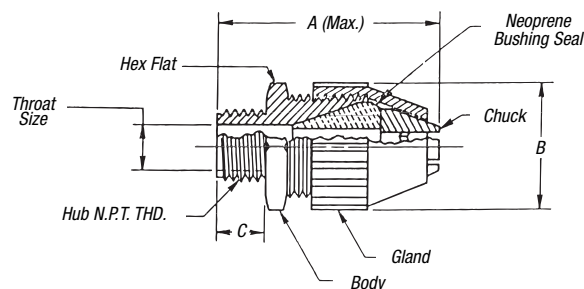

| CAT. NO. | HUB SIZE | UF CABLE RANGE |             | A    | B     | C     |
|----------|----------|----------------|-------------|------|-------|-------|
|          |          | MAX.           | MIN.        | MAX. | ±.060 | ±.060 |
| 2827     | 1/2"     | .550 x .280    | .400 x .190 | 2.60 | 1.270 | .600  |
| 2828     | 3/4"     | .675 x .280    | .525 x .190 | 3.00 | 1.570 | .620  |
| 2829     | 3/4"     | .775 x .280    | .625 x .190 | 3.00 | 1.570 | .620  |

UL File No. 15170

CSA File No. 589

## MC and AC Cable Fittings

### Metal-Clad Cable, Armored Cable and Flexible Metal Conduit

#### Armored Cable (Type AC) — Ref. NEC® Article 320

National Electrical Code® defines type AC armored cable as, "A fabricated assembly of insulated conductors in a flexible metallic enclosure."

- ACT** Indicates an armored cable employing conductors having thermoplastic (Type T) insulation.
- AC** Indicates an armored cable employing conductors having rubber insulation of code grade.
- ACH** Indicates an armored cable employing conductors having rubber insulation of the heat-resistant (75° C) grade.
- ACHH** Indicates an armored cable employing conductors having rubber insulation of the heat-resistant (90° C) grade.
- ACU** Indicates an armored cable employing conductors having rubber insulation of latex grade.
- "L"** Used as a suffix, it indicates that a lead covering has been applied over the conductor assembly.

All armored cables may employ copper or aluminum or copperclad aluminum conductors with the following sizes and are rated for 600 volts or less:

No. 14 AWG to No. 1 AWG Copper

No. 12 AWG to No. 1 AWG Aluminum or Copperclad Aluminum

Type AC cables except ACL carry an internal bonding strip of copper or aluminum in intimate contact with the armor for its entire length. Armored cable can be used for both exposed or concealed locations. With lead-covered conductors (Type ACL), the cable can be embedded in masonry or concrete and can be used in damp locations or where exposed to oil.

Armored cable is not permitted in locations where it will be subjected to physical damage or corrosive fumes. Armored cable cannot be used for direct burial in earth.

With minor exceptions, armored cable is also not permitted to be used in hoists or elevators, storage battery rooms, any hazardous locations, in commercial garages and in theaters or similar locations.

Codes require that cable shall be supported with straps or staples without damaging conductors and also limit the minimum bend radius to five times the diameter of type AC cable. Certain precautions are prescribed in code where cable is installed through joist rafters or similar wood members.

According to NEC 320 where armored cable is terminated, a fitting is required to protect conductors from abrasion. In addition, a bushing is required between the conductors and armor. Design of fitting has to be such that the insulating bushing is visible for inspection. Bushing is not required with lead-covered cables when properly installed.

Portions of this section reprinted by permission from NFPA 70–2005, National Electrical Code®, Copyright © 2004, National Fire Protection Association, Boston, MA.

Please refer to the following for further details and complete information:

1. NEC Article 320...Armored Cable (Type AC Cable)
2. UL 4, ANSI C33.9...Safety Standards for Armored Cable
3. UL 514B, Safety Standards for Outlet Boxes and Fittings
4. A-A-50552...Federal Specification. Fittings for Cable, Power, Electrical and Conduit, Metal, Flexible
5. NEMA FB-1...Standards Publication. Fittings & Supports for Conduit and Cable Assemblies
6. CEC Section 12-700...Wiring Methods (Armored Cable)
7. CSA C22.2 No. 51...Safety Standards for Armored Cables
8. CSA C22.2 No. 18...Safety Standards for Outlet Boxes, Conduit Boxes and Fittings

**Note:** The materials herein, whether relating to the National Electrical Code, the Underwriters Laboratories, Inc. listing, to industry practice or otherwise, are not intended to provide all relevant information required for use and installation of our products. Refer to applicable codes, instructions and industry specifications prior to installation or use.

## MC and AC Cable Fittings

### Flexible Metal Conduit — Ref. NEC® Article 348

Flexible metal conduit can be used for exposed or concealed work in dry locations. It can be used for wet locations provided conductors within are lead covered or other approved type.

Flexible metal conduit cannot be used underground or embedded in poured concrete or aggregate. With rubber covered conductors, the conduit cannot be exposed to oil, gasoline or other materials having a deteriorating effect on rubber.

With minor exceptions use of flexible metal conduit is not permitted in hoists, in storage battery rooms and in any hazardous locations. Use of flexible metal conduit is restricted to systems under 600 volts.

According to NEC® Article 348, flexible metal conduit no longer than six feet and containing circuit conductors protected by overcurrent device rated for 20 amps or less is suitable as a grounding means provided, it is terminated in fittings approved for the purpose.

Flexible metal conduit longer than six feet is permitted to be used as a grounding means provided the conduit and the fitting are approved for the purpose. To date, there is no flexible metal conduit approved for the purpose by the Underwriters Laboratories.

In Class I & II, Division 2 hazardous areas, the conduit itself cannot be used as the grounding means. A bonding jumper must be installed in accordance with NEC Section 250.102. Flexible metal conduit is available with steel or aluminum armor in trade size 3/8" to 4". With few exceptions where 3/8" and 3/4" trade sizes are used, Code prohibits use of conduit less than "d" trade size. Bends in concealed work are restricted to 360 degrees total. No angle connectors are permitted in concealed raceway installations.

Portions of this section reprinted by permission from NFPA 70, National Electrical Code®, Copyright © 2010, National Fire Protection Association, Boston, MA.

*NEC and National Electrical Code are registered trademarks of the National Fire Protection Association, Inc.*

Please refer to the following for further details and complete information:

1. NEC Article 348...Flexible Metal Conduit
2. UL 1, ANSI C33.92...Safety Standards for Flexible Metal Conduit
3. UL 514B, Safety Standards for Outlet Boxes and Fittings
4. A-A-50552...Federal Specification. Fittings for Cable, Power, Electrical and Conduit, Metal Flexible
5. WW-C-566...Federal Specification. Conduit, Metal, Flexible
6. NEMA FB1...Standards Publication. Fittings and Supports for Conduit and Cable Assemblies
7. CEC 12-1100...Wiring Method (Rigid & Flexible Conduit)
8. CSA C22.2 No. 56...Safety Standards for Flexible Metallic Conduit and Liquidtight Flexible Metal Conduit
9. CSA C22.2 No. 18...Safety Standards for Outlet Boxes, Conduit Boxes and Fittings

## Suggested Specifications for Armored Cable and Flexible Metal Conduit Fittings

- Armored cable (metal-clad cable type AC) and flexible metal conduit shall conform to provisions of following applicable standards:

*Armored Cable...UL 4/ANSI C33.9/CSA 22.2 No. 51*

*Flexible Metal Conduit...UL 1/ANSI C33.92/WW-C-566/CSA 22.2 No. 56*

*Type of cable used and conductors within flexible metal conduit shall be suitable for conditions of use and location.*

- Where approved armored cable or flexible metal conduit is used as an equipment grounding conductor, terminating fitting used shall be of the grounding type as manufactured by Thomas & Betts, series 3110

- Where armored cable or flexible metal conduit terminates into a threadless or threaded opening, it shall be assembled with approved fittings; fittings shall be of malleable iron/steel construction, electro zinc plated inside/outside, equipped with nylon insulated throat and shall be of angled saddle type as manufactured by Thomas & Betts, series 3110. Direct-bearing screw type fittings shall not be used

- Suitable bushing as manufactured by Thomas & Betts, series 422 or 390, shall be provided between the conductors and armor



**Series 3110**  
Armored Cable Connector  
& Flexible Metal Conduit



**Series 390**  
Anti-Short Bushing



## MC and AC Cable Fittings

### TITE-BITE® Connectors

#### Application

- To connect and effectively bond metal-clad cables, armored cable or flexible metal conduit to a box or an enclosure

#### Features

- Provided with an angled saddle designed to:
- Insulated throat protects conductors during and after installation and reduces wire pull effort
- Heat-curved insulator in throat:
- Locknuts designed to provide effective bond between connector and box or enclosure, will not vibrate loose
- Designed with fewer installing screws — reduces installation time and labor cost
- Armor stop with viewing window
- Rugged all-steel or malleable iron construction
- Suitable as a grounding means per NEC® Article 348 for flexible metal conduit, NEC® Article 320 for armored cable and NEC® Article 330 for metal-clad cable
- Suitable for hazardous location use per Class 1 Division 2 NEC 501.10 (b)(2)

#### Typical Installation

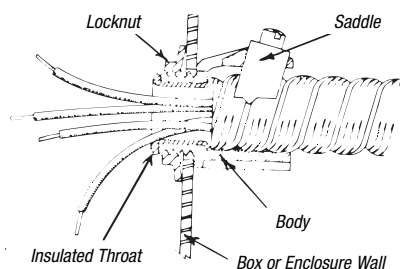

3110 Series

#### Standard Material/Finish

|           |  |
|-----------|--|
| Body      | Steel or Malleable Iron/<br>Electro Zinc Plated &<br>Chromate Coated |
| Saddle    | Steel/Electro Zinc Plated<br>& Chromate Coated                       |
| Screws    | Steel/Electro Zinc Plated &<br>Chromate Coated                       |
| Insulator | Thermoplastic/As Molded  |

#### Listings/Compliances

|      |                     |
|------|---------------------|
| UL   | 514B                |
| CSA  | C22.2 No. 18        |
| NEMA | FB1                 |
| UL   | (UL File No. 23018) |
| CSA  | (LR-2884, LR-4484)  |

**Super-Fast  
Installation!**

*Up to 2X faster  
than standard  
connectors!*

**Very High  
Cable Pull-Out  
Resistance!**

**Now UL Listed  
for New Interlocked  
Armor Ground Type  
Metal Clad Cable  
(MCI-A)!**

| RANGE                           | HUB SIZE     | CONDUIT SIZE | CABLE OPENING   |
|---------------------------------|--------------|--------------|-----------------|
| 3110 Series Straight Connectors | ½" to 4" NPS | ¾" to 4"     | .470" to 4.560" |
| 3130 Series 90° Connectors      | ½" to 4" NPS | ¾" to 4"     | .470" to 4.560" |

(All hubs provided with straight pipe threads NPS)

## MC and AC Cable Fittings

Designed to resist vibration and strain!



### TITE-BITE® Connectors — Nylon Insulated



- Super-fast installation and extreme pull-out resistance due to angled saddle design
- Steel or malleable iron construction
- Tough, insulated lining and Tite-Bite® design make these connectors a “must” when conductors are subject to vibration or strain
- Look for the unique T&B blue color to ensure the highest quality fitting

| CAT. NO.   | CABLE OPENING (IN.) |       | TRADE SIZE | K.O. SIZE | DIMENSIONS (IN.) |        |          |
|------------|---------------------|-------|------------|-----------|------------------|--------|----------|
|            | MAX.                | MIN.  |            |           | A†               | B      | C        |
| 2492*•#    | .500                | .370  | 3/8"       | 1/2"      | 1 1/16"          | 1 1/8" | 7/16"    |
| 3110-TB**• | .660                | .470  | 3/8"       | 1/2"      | 1 1/4"           | 1 1/8" | 7/8"     |
| 3112#°     | .920                | .670  | 1/2"       | 1/2"      | 1 1/4"           | 1 1/8" | 7/8"     |
| 3115#      | 1.125               | .906  | 3/4"       | 3/4"      | 1 25/32"         | 1 1/4" | 1 1/32"  |
| 3117#      | 1.468               | 1.250 | 1"         | 1"        | 2 3/8"           | 1 3/4" | 1 1/8"   |
| 3118***    | 1.750               | 1.562 | 1 1/4"     | 1 1/4"    | 2 3/4"           | 2"     | 1 1/4"   |
| 3119***    | 2.031               | 1.812 | 1 1/2"     | 1 1/2"    | 3 1/8"           | 2 5/8" | 1 3/4"   |
| 3120***    | 2.500               | 2.312 | 2"         | 2"        | 3 3/4"           | 2 3/4" | 1 13/16" |
| 3121***    | 3.062               | 2.812 | 2 1/2"     | 2 1/2"    | 4 3/8"           | 3 3/4" | 2 1/4"   |
| 3122***    | 3.562               | 3.312 | 3"         | 3"        | 5"               | 3 3/4" | 2 1/4"   |
| 3123****†  | 4.060               | 3.620 | 3 1/2"     | 3 1/2"    | —                | —      | —        |
| 3124****†  | 4.560               | 4.120 | 4"         | 4"        | —                | —      | —        |

Material: Steel thru 3/4" trade size.

UL File No. E 23018

CSA File No. 2884

#UL Listed for Metal Clad Cable (MCI).

•UL Listed for new Interlocked Armor Ground Type Metal Clad Cable (MCI-A).

\*Good for aluminum-sheathed cable.

\*\*UL Listed for Armored Cable and Metal Clad Cable.

\*\*\*UL Listed for Flexible Metal Conduit only.

†Approximate dimension with screw at minimum height.

††CSA not applicable.

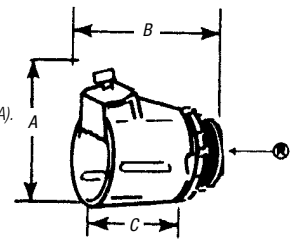

### Easy to install!

### TITE-BITE® Connectors



- Easy to install with double-grip saddle
- 3/8" and 1/2" sizes made of formed steel, which produces uniform high quality and a smooth throat to protect conductor insulation
- 3/4" and larger size are malleable iron

| CAT. NO.  | CABLE OPENING (IN.) |       | TRADE SIZE | K.O. SIZE | DIMENSIONS (IN.) |          |          |
|-----------|---------------------|-------|------------|-----------|------------------|----------|----------|
|           | MAX.                | MIN.  |            |           | A†               | B        | C        |
| 300-TB**• | .660                | .470  | 3/8"       | 1/2"      | 1 1/4"           | 1 5/16"  | 7/16"    |
| 301-TB*•  | .781                | .460  | 3/8"       | 1/2"      | 1 1/8"           | 1 1/8"   | 7/8"     |
| 302-TB#•  | .920                | .670  | 1/2"       | 1/2"      | 1 1/8"           | 1 11/16" | 1 1/64"  |
| 304#      | 1.093               | .906  | 3/4"       | 3/4"      | 1 1/8"           | 1 11/16" | 1 1/32"  |
| 306#      | 1.468               | 1.250 | 1"         | 1"        | 2 1/16"          | 1 3/4"   | 1 3/4"   |
| 308***    | 1.750               | 1.562 | 1 1/4"     | 1 1/4"    | 2 5/16"          | 2 1/32"  | 1 1/4"   |
| 310***    | 2.031               | 1.812 | 1 1/2"     | 1 1/2"    | 2 5/8"           | 2 9/16"  | 1 3/4"   |
| 312***    | 2.500               | 2.312 | 2"         | 2"        | 3 1/8"           | 2 9/16"  | 1 13/16" |
| 314***    | 3.062               | 2.812 | 2 1/2"     | 2 1/2"    | 3 1/2"           | 3 1/8"   | 2 1/4"   |
| 316***    | 3.562               | 3.312 | 3"         | 3"        | 4 1/16"          | 3 3/16"  | 2 1/4"   |
| 318****†  | 4.060               | 3.620 | 3 1/2"     | 3 1/2"    | —                | —        | —        |
| 320****†  | 4.560               | 4.120 | 4"         | 4"        | —                | —        | —        |

Material: Steel thru 1/2" trade size.

UL File No. E 23018

CSA File No. 2884

#UL Listed for Metal Clad Cable (MCI).

•UL Listed for new Interlocked Armor Ground Type Metal Clad Cable (MCI-A).

\*Not UL Listed.

\*\*UL Listed for Armored Cable and Metal Clad Cable.

\*\*\*UL Listed for Flexible Metal Conduit only.

†Approximate dimension with screw at minimum height.

††CSA not applicable.

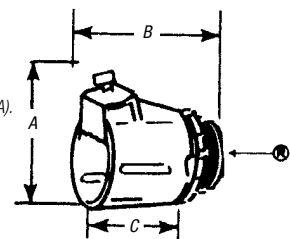

## MC and AC Cable Fittings

The easiest and best connector to install when making sharp bends at the enclosure or equipment!

### TITE-BITE® Connectors — 90° Angle Nylon Insulated



- Steel or malleable iron construction
- Offers all of the advantages of the straight connector with only one screw to tighten, except in the larger sizes, which have two
- Peep hole on top provides for easy inspection of ABC bushing
- Narrow design makes it easy to install connectors in adjacent knockouts

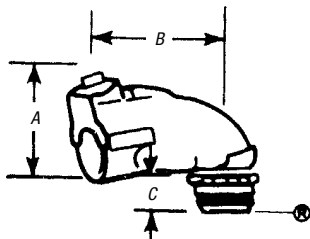

| CAT. NO.     | CABLE OPENING (IN.) |       | TRADE SIZE | K.O. SIZE | DIMENSIONS (IN.) |         |       |
|--------------|---------------------|-------|------------|-----------|------------------|---------|-------|
|              | MAX.                | MIN.  |            |           | A†               | B       | C     |
| 3130-TB#•    | .660                | .470  | 3/8"       | 1/2"      | 1 11/32          | 1 19/32 | 15/16 |
| 3132#•       | .920                | .670  | 1/2"       | 1/2"      | 1 7/8            | 2 5/16  | 15/16 |
| 3135#        | 1.093               | .906  | 3/4"       | 3/4"      | 2 1/8            | 2 1/8   | 9/16  |
| 3137#        | 1.468               | 1.250 | 1"         | 1"        | 2 21/32          | 2 1/8   | 1/2   |
| 3138***      | 1.750               | 1.562 | 1 1/4"     | 1 1/4"    | 3 3/16           | 3 3/32  | 9/16  |
| 3139***      | 2.031               | 1.812 | 1 1/2"     | 1 1/2"    | 4                | 4 1/8   | 11/16 |
| 3140***      | 2.500               | 2.312 | 2"         | 2"        | 4 15/16          | 5 1/16  | 11/16 |
| 3141***      | 3.062               | 2.812 | 2 1/2"     | 2 1/2"    | 6 3/32           | 6       | 3/4   |
| 3142***      | 3.562               | 3.312 | 3"         | 3"        | 7 11/32          | 7 1/16  | 3/4   |
| 3143****†    | 4.060               | 3.620 | 3 1/2"     | 3 1/2"    | —                | —       | —     |
| 3144-TB****† | 4.560               | 4.120 | 4"         | 4"        | —                | —       | —     |

UL File No. E 23018

CSA File No. 2884

#UL Listed for Metal Clad Cable (MCI).

•UL Listed for new Interlocked Armor Ground Type Metal Clad Cable (MCI-A).

\*\*\*UL Listed for flexible metal conduit only.

†Approximate dimension with screw at minimum height.

††CSA not applicable.

Angle clip provides secure mechanical grip that tightens under tension or vibration!



### TITE-BITE® Connectors — 90° Angle

- Throat is long enough to install in cast housing knockouts
- 3/8" and 1/2" sizes of steel construction
- 3/4" and larger sizes made of malleable iron

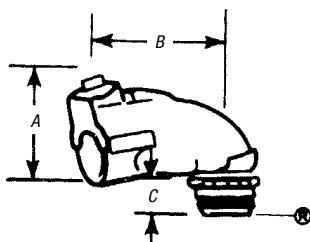

| CAT. NO.     | CABLE OPENING (IN.) |       | TRADE SIZE | K.O. SIZE | DIMENSIONS (IN.) |        |       |
|--------------|---------------------|-------|------------|-----------|------------------|--------|-------|
|              | MAX.                | MIN.  |            |           | A†               | B      | C     |
| 321#•        | .660                | .470  | 3/8"       | 1/2"      | 1 11/32          | 1 1/2  | 3/8   |
| 323#•        | .920                | .670  | 1/2"       | 1/2"      | 1 7/8            | 2 5/8  | 17/32 |
| 325#         | 1.093               | .906  | 1/2"       | 3/4"      | 2 1/8            | 2 1/8  | 1/2   |
| 326-TB#      | 1.468               | 1.250 | 1"         | 1"        | 2 21/32          | 2 1/8  | 1     |
| 327-TB***    | 1.750               | 1.562 | 1 1/4"     | 1 1/4"    | 3 3/8            | 3 3/8  | —     |
| 328***       | 2.031               | 1.812 | 1 1/2"     | 1 1/2"    | 4 1/8            | 4 1/8  | —     |
| 329***       | 2.500               | 2.312 | 2"         | 2"        | 4 3/8            | 4 3/32 | —     |
| 330-TB***    | 3.062               | 2.812 | 2 1/2"     | 2 1/2"    | 6 1/2            | 6      | —     |
| 331***       | 3.562               | 3.312 | 3"         | 3"        | 5 25/32          | 7      | —     |
| 332††        | 4.060               | 3.620 | 3 1/2"     | 3 1/2"    | —                | —      | —     |
| 333††        | 4.560               | 4.120 | 4"         | 4"        | —                | —      | —     |
| 3144-TB****† | 4.560               | 4.120 | 4"         | 4"        | —                | —      | —     |

UL File No. E 23018

CSA File No. 2884

#UL Listed for Metal Clad Cable (MCI).

•UL Listed for new Interlocked Armor Ground Type Metal Clad Cable (MCI-A).

\*\*\*UL Listed for flexible metal conduit only.

†Approximate dimension with screw at minimum height.

††CSA not applicable.



## MC and AC Cable Fittings

Fits every size of armored cable, metal-clad cable and flexible metal conduit!

### Squeeze Connectors — Straight

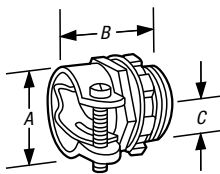

- Malleable iron or steel construction
- Catalog Nos. 252, 253-TB, 254-TB and 255 are steel
- Add "I" suffix for insulated throat

| CAT. NO.    | INS. CAT. NO. | CABLE OPENING (IN.) |       | TRADE SIZE | K.O. SIZE | DIMENSIONS (IN.) |         |        |
|-------------|---------------|---------------------|-------|------------|-----------|------------------|---------|--------|
|             |               | MAX.                | MIN.  |            |           | A†               | B       | C      |
| 252***      | —             | .531                | .437  | 5/16"      | 3/8"      | 13/16            | 29/32   | 11/32  |
| 253-TB***†  | 253-I-TB***†  | .585                | .455  | 3/8"       | 1/2"      | 31/32            | 113/64  | 5/8    |
| 254-TB      | 254-I-TB      | .938                | .812  | 1/2"       | 1/2"      | 17/32            | 1 1/8   | 13/32  |
| 255         | 255-I         | 1.094               | .938  | 3/4"       | 3/4"      | 1 1/4            | 1 17/32 | 7/16   |
| 256         | 256-I         | 1.375               | 1.250 | 1"         | 1"        | 1 19/32          | 1 5/8   | 1/2    |
| 257***      | 257-I***      | 1.656               | 1.500 | 1 1/4"     | 1 1/4"    | 1 7/8            | 1 23/32 | 17/32  |
| 258***      | 258-I***      | 1.875               | 1.688 | 1 1/2"     | 1 1/2"    | 2 1/4            | 1 7/16  | 9/16   |
| 259***      | 259-I***      | 2.500               | 2.313 | 2"         | 2"        | 2 31/32          | 2 5/8   | 1 1/16 |
| 249***      | 249-I***      | 3.062               | 2.812 | 2 1/2"     | 2 1/2"    | 3 5/16           | 2 11/16 | 3/4    |
| 277***      | 277-I***      | 3.563               | 3.312 | 3"         | 3"        | 3 31/16          | 2 7/8   | 3/4    |
| 278-TB***†† | 278-I-TB***†† | 4.370               | 3.200 | 3 1/2"     | 3 1/2"    | 6 7/8            | 5 1/4   | 1 5/16 |
| 281-TB***†† | 281-I-TB***†† | 4.600               | 3.500 | 4"         | 4"        | 7 1/4            | 5 3/4   | 1 5/8  |

\*\* UL Listed for armored cable only. Fitting material steel.

\*\*\* UL Listed for flexible metal conduit only.

† Approximate dimension with screw at minimum height.

†† cULus Certified

.485"–.660" cable opening range for 253-I-TB.

UL File No. E 23018

CSA File No. 2884

### Only two screws to tighten!

### Squeeze Connectors — 90° Angle

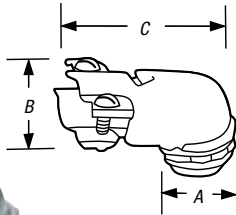

- Cap lifts off simply by loosening screws partway
- 3/8" and 1/2" sizes made of steel
- 3/4" and larger sizes made of malleable iron
- Add "I" suffix for insulated throat

| CAT. NO.    | INS. CAT. NO. | CABLE OPENING (IN.) |       | TRADE SIZE | K.O. SIZE | DIMENSIONS (IN.) |         |         |
|-------------|---------------|---------------------|-------|------------|-----------|------------------|---------|---------|
|             |               | MAX.                | MIN.  |            |           | A†               | B       | C       |
| 266-TB      | 266-I-TB      | .656                | .406  | 3/8"       | 1/2"      | 1 1/2            | 1 13/32 | 1 7/16  |
| 272**       | 272-I**       | .812                | .688  | 3/8"       | 1/2"      | 1 1/8            | 1 1/8   | —       |
| 268-TB      | 268-I-TB      | .937                | .813  | 1/2"       | 1/2"      | 1 11/16          | 1 13/16 | 1 1/8   |
| 279         | 279-I         | 1.000               | .875  | 3/4"       | 3/4"      | 1 13/16          | 2 1/16  | 1 13/16 |
| 270         | 270-I         | 1.125               | 1.000 | 3/4"       | 3/4"      | 1 7/8            | 1 3/4   | 1 13/16 |
| 273-TB      | 273-I-TB      | 1.406               | 1.187 | 1"         | 1"        | 2 3/8            | 2 7/32  | 2 1/16  |
| 274***      | 274-I***      | 1.656               | 1.375 | 1 1/4"     | 1 1/4"    | 3                | 3       | 3       |
| 275***      | 275-I***      | 1.875               | 1.625 | 1 1/2"     | 1 1/2"    | 3 3/8            | 3 5/16  | 4       |
| 276***      | 276-I***      | 2.500               | 2.125 | 2"         | 2"        | 4 1/2            | 3 31/16 | 4 7/8   |
| 282-TB***†† | 282-I-TB***†† | 3.100               | 2.520 | 2 1/2"     | 2 1/2"    | 4 7/16           | 5 7/16  | 7 7/16  |
| 283-TB***†† | 283-I-TB***†† | 3.640               | 3.100 | 3"         | 3"        | 5 1/16           | 6 3/16  | 8 5/16  |
| 284-TB***†† | 284-I-TB***†† | 4.220               | 3.700 | 3 1/2"     | 3 1/2"    | 6 3/16           | 8 3/16  | 11 1/4  |
| 285-TB***†† | 285-I-TB***†† | 4.600               | 4.100 | 4"         | 4"        | 7 1/4            | 8 7/8   | 12 3/8  |

\*\* UL Listed for armored cable only.

\*\*\* UL Listed for flexible metal conduit only.

† Approximate dimension with screw at minimum height.

†† cULus Certified

UL File No. E23018

CSA File No. 2884

### Fast and easy installation — simply loosen screws partway to lift off cap!

### Squeeze Connectors — 45° Angle

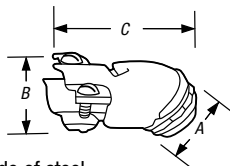

- 3/8" and 1/2" sizes made of steel
- 3/4" size made of malleable iron
- Add "I" suffix for insulated throat

| CAT. NO. | INS. CAT. NO. | CABLE OPENING (IN.) |       | TRADE SIZE | K.O. SIZE | DIMENSIONS (IN.) |        |        |
|----------|---------------|---------------------|-------|------------|-----------|------------------|--------|--------|
|          |               | MAX.                | MIN.  |            |           | A†               | B      | C      |
| 265      | 265-I         | .656                | .406  | 3/8"       | 1/2"      | 1 17/32          | 1 5/32 | 1 1/8  |
| 267      | 267-I         | .937                | .813  | 1/2"       | 1/2"      | 1 23/32          | 1 1/2  | 1 1/4  |
| 269      | 269-I         | 1.125               | 1.000 | 3/4"       | 3/4"      | 2                | 1 7/32 | 1 1/16 |

UL File No. E-23018

CSA File No. 2884

UL Listed for armored cable and flexible metal conduit.

† Approximate dimension with screw at minimum height.

## MC and AC Cable Fittings

Armor-gripping saddle stays open by itself when cable is being inserted!

### Two-Screw Connectors

- Formed steel body
- Carefully round bushing

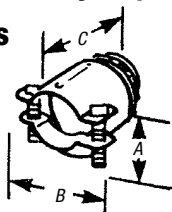

| CAT. NO.  | CABLE OPENING (IN.) |      | TRADE SIZE | K.O. SIZE | DIMENSIONS (IN.) |        |        |
|-----------|---------------------|------|------------|-----------|------------------|--------|--------|
|           | MAX.                | MIN. |            |           | A†               | B      | C      |
| 3301-TB** | .656                | .250 | 3/8"       | 1/2"      | 31/32            | 1 1/16 | 1 1/16 |
| 3312-TB   | .937                | .500 | 1/2"       | 1/2"      | 1 1/32           | 1 1/8  | 1 1/8  |

\*\* UL Listed for armored cable only. UL File No. E 1383  
CSA File No. 2884



TITE-BITE® design holds flexible metal cable firmly in place with a single screw!

### Adapter — EMT to Flex

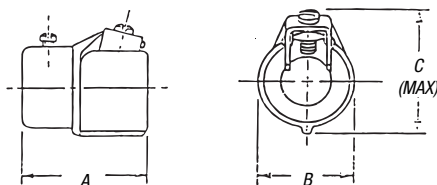

| CAT. NO. | SIZE        | DIMENSIONS (IN.) |        |       |
|----------|-------------|------------------|--------|-------|
|          | FLEX TO EMT | A                | B      | C     |
| 503TB    | 1/2" - 1/2" | 1 2/32           | 1 1/16 | 1 1/8 |
| 504      | 3/4" - 3/4" | 1 25/32          | 1 1/16 | 2 1/8 |
| 505-TB   | 1" - 1"     | 2 1/32           | 2 1/16 | 2 5/8 |

CSA File No. 8994  
UL File No. E-23018



Smooth plastic bushing protects conductor insulation from rough edges of armored cable and flexible metal conduit!

### Anti-Short Bushing



| CAT. NO. | SIZE (AWG)                             |
|----------|--|
| 390      | #14-2, #14-3, #12-2                    |
| 391      | #14-4, #12-3, #6-1, and #4-1           |
| 392      | #12-4, #10-2, #10-3 and #2-1           |
| 393      | #10-4, #8-2, #8-3, and #1-1            |
| 394      | #8-4, #6-2, #6-3, #4-2, #4-3, and #6-4 |

Colorized. CSA File No. 589  
Temperature Rating: 240° F. UL not applicable.

For flexible metal conduit and armored cable.

### Duplex Clamp Connector

- Malleable iron construction

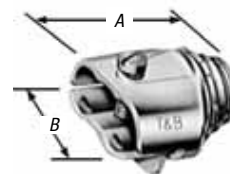

| CAT. NO. | K.O. SIZE | DIMENSIONS (IN.) |         |
|----------|-----------|------------------|---------|
|          |           | A                | B       |
| 291-TB   | 1/2"      | 1 1/32"          | 1 1/16" |

UL File No. E 1383  
CSA File No. 2884

One-piece fitting couples 3/8" flexible metal conduit to 1/2" EMT!

### Combination Coupling

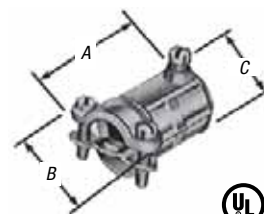

| CAT. NO. | SIZE        | DIMENSIONS (IN.) |        |        |
|----------|-------------|------------------|--------|--------|
|          | FLEX TO EMT | A                | B      | C      |
| 449-TB   | 3/8" - 1/2" | 1 2/32           | 1 1/32 | 1 5/16 |

Cable opening: max. .656, min. .250. UL File No. E-23018  
CSA File No. 2884

Fast and easy installation!

### Strap

- Elongated bolt hole makes alignment easy, even when holes in mounting surface are off center
- Snap-on design holds strap in place



| CAT. NO. | SIZE      |
|----------|-----------|
| 65-TB    | 3/8" Flex |



## Tray Cable Fittings

Increase safety for hazardous locations.

### Silver Grip® TCF® Series — Tray Cord Fitting

Introducing the Silver Grip® Tray Cord Fitting — the safe, yet cost-efficient choice for increased safety when terminating portable cord and tray cable in hazardous locations. Designed for use in Class I, Gas and Vapor environments, the Silver Grip® Tray Cord Fitting provides efficient strain relief for cables entering enclosures and raceways, and for cords used on portable equipment.

- Now available in stainless steel in hub sizes from ½" to 1"
- Corrosion-resistant, non-magnetic aluminum construction
- Tapered neoprene bushing and O-ring seal out moisture and dirt ingress
- Chuck grip provides high mechanical pull-out performance. Exceeds applicable requirements
- Hand-tightens — no tools required

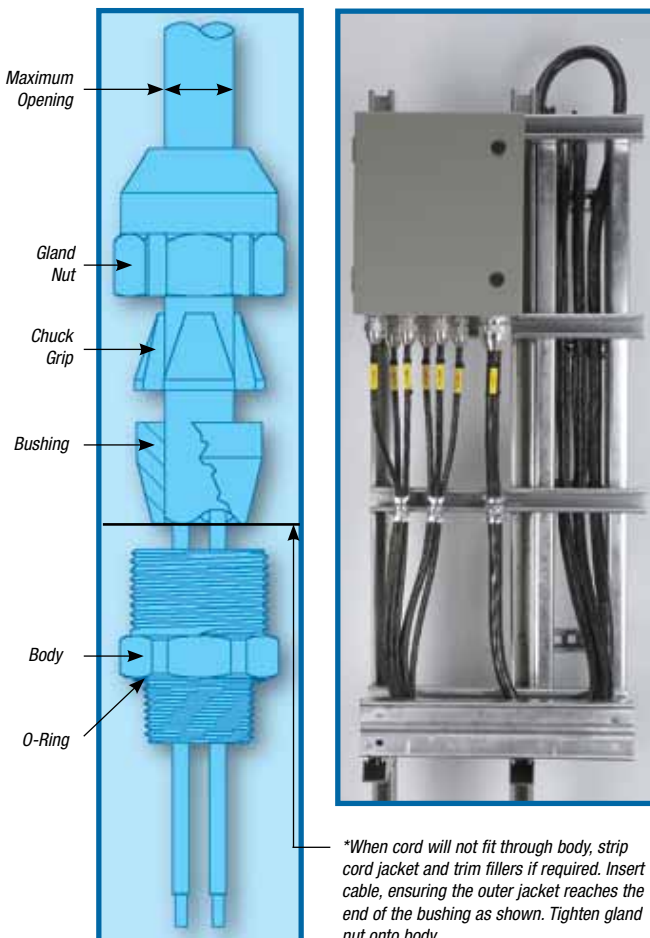

\*When cord will not fit through body, strip cord jacket and trim fillers if required. Insert cable, ensuring the outer jacket reaches the end of the bushing as shown. Tighten gland nut onto body.

**Now Available  
in Stainless  
up to 1"**

#### Applications

**Tray Cable:** Complies with IEC requirements for Class I, Zone 2 locations when used with enclosures containing no arcing or sparking devices. For enclosures with arcing or sparking devices, TCF® fittings must be used in combination with a certified Class I hazardous location sealing fitting.

**Portable Cord:** Complies with IEC requirements for Class I, Zone 1 locations when used with enclosures containing no arcing or sparking devices. For enclosures with arcing or sparking devices, TCF® fittings must be used in combination with a certified Class I hazardous location sealing fitting.

**Note:** Tray cable is not suitable for use in Zone 1 locations. Portable cord can be used in Zone 1 applications only when installed on portable equipment.

- CSA File Number LR4484
- Class 4418-03 Fittings for Hazardous Locations
- Class 4418-03 Fittings for Hazardous Locations — Certified to U.S. Standards
- Class I, Zone 1, AEx e II



| CAT. NO.     | HUB SIZE<br>NPT | THROAT<br>DIA.<br>(IN.) | MIN.<br>CABLE<br>DIA.<br>(IN.) | MAX.<br>OPENING<br>(IN.) | STD. PKG.<br>QTY. |
|--------------|-----------------|-------------------------|--------------------------------|--------------------------|-------------------|
| TCF050-27AL  | ½               | .330                    | .150                           | .270                     | 25                |
| TCF050-40AL  | ½               | .540                    | .250                           | .400                     | 25                |
| TCF050-54AL  | ½               | .540                    | .400                           | .540                     | 25                |
| TCF050-67AL  | ½               | .540                    | .540                           | .670                     | 10                |
| TCF050-78AL  | ½               | .540                    | .660                           | .780                     | 10                |
| TCF075-40AL  | ¾               | .540                    | .250                           | .400                     | 15                |
| TCF075-54AL  | ¾               | .540                    | .400                           | .540                     | 15                |
| TCF075-67AL  | ¾               | .780                    | .540                           | .670                     | 10                |
| TCF075-78AL  | ¾               | .780                    | .660                           | .780                     | 10                |
| TCF075-88AL  | ¾               | .765                    | .770                           | .880                     | 10                |
| TCF100-78AL  | 1               | .980                    | .660                           | .780                     | 10                |
| TCF100-88AL  | 1               | .980                    | .770                           | .880                     | 10                |
| TCF100-100AL | 1               | .980                    | .870                           | 1.000                    | 10                |
| TCF125-109AL | 1¼              | 1.255                   | .800                           | 1.090                    | 4                 |
| TCF125-128AL | 1¼              | 1.255                   | 1.080                          | 1.280                    | 4                 |
| TCF125-147AL | 1¼              | 1.255                   | 1.270                          | 1.470                    | 4                 |
| TCF150-115AL | 1½              | 1.470                   | .890                           | 1.150                    | 2                 |
| TCF150-140AL | 1½              | 1.470                   | 1.140                          | 1.400                    | 2                 |
| TCF150-165AL | 1½              | 1.470                   | 1.390                          | 1.650                    | 2                 |
| TCF200-153AL | 2               | 1.896                   | 1.190                          | 1.530                    | 2                 |
| TCF200-186AL | 2               | 1.896                   | 1.520                          | 1.860                    | 2                 |
| TCF200-219AL | 2               | 1.896                   | 1.850                          | 2.190                    | 2                 |
| TCF250-252AL | 2½              | 2.466                   | 2.120                          | 2.520                    | —                 |
| TCF300-278AL | 3               | 2.780                   | 2.380                          | 2.780                    | —                 |
| TCF300-304AL | 3               | 3.037                   | 2.640                          | 3.040                    | —                 |
| TCF300-330AL | 3               | 3.068                   | 2.900                          | 3.300                    | —                 |

For stainless steel (316), replace AL with SS6 (up to 1" only)

## Non-Metallic Sheathed Cable Fittings

### Non-Metallic Sheathed Cable

#### Ref. NEC® Article 334

Code defines non-metallic sheathed cable as, "A factory assembly of two or more insulated conductors having an outer sheath of moisture resistant, flame retardant, non-metallic material."

Non-metallic sheathed cable is constructed of insulated conductors (#14 to #2 AWG Copper or #12 to #2 AWG Aluminum or Copperclad Aluminum), and an outer non-metallic sheath classified as Type NM or Type NMC.

Non-metallic sheathed cable is provided with or without a bare or insulated equipment grounding conductor. Non-metallic sheathed cable is rated for 60° C service with voltage limitation of 600 volts.

Type NM — has flame-retardant moisture resistant sheath.

Type NMC — has flame-retardant, moisture-resistant, fungus-resistant and corrosion-resistant sheath.

Non-metallic sheathed cable is permitted by code to be used exposed or concealed in one, two or multifamily dwellings or other structures not exceeding three floors. Use of Type NM cable is restricted to dry locations whereas Type NMC can be used in dry, moist, damp or corrosive environments.

Non-metallic sheathed cable (both Type NM & NMC) is not permitted to be used as a service conductor, in commercial garages, in hoists or cannot be embedded in cement, concrete or aggregate. With minor exceptions, use of non-metallic sheathed cable is also prohibited in theaters or any hazardous locations.

NEC® Section 334.30 requires that cable be secured in place by suitable means so as not to injure the cable. Adequate protection for cable is also required when run is exposed, through joists or rafters, through floors, in unfinished basements and accessible attics.

Cable bends are limited to a minimum of five times the diameter of the cable.

NEC® 300.4(B) requires that cable be protected from physical damage when it passes through factory or field punched, cut or drilled holes in metal members. A bushing or grommet firmly secured in place is recommended.

Portions of this section reprinted by permission from NFPA 70-2011, National Electrical Code®.

Copyright © 2010, National Fire Protection Association, Boston, MA.

#### Please refer to the following for further details and complete information:

1. NEC® Article 334...Non-Metallic Sheathed Cable (Type NM & NMC)
2. NEC® Article 300...Wiring Methods
3. UL 719, ANSI C33.56...Safety Standards for Non-Metallic Sheathed Cable
4. UL 514B, Safety Standards for Outlet Boxes and Fittings
5. NEMA FB-1...Standards Publication. Fittings and Supports for Conduit and Cable Assemblies
6. CEC Section 12-600...Wiring Methods (Non-Metallic Sheathed Cable)
7. CSA C22.2 No. 48...Safety Standards for Non-Metallic Sheathed Cable
8. CSA C22.2 No. 18...Safety Standards for Outlet Boxes, Conduit Boxes and Fittings

*NEC and National Electrical Code are registered trademarks of the National Fire Protection Association, Inc.*

#### Note:

The materials herein, whether relating to the National Electrical Code®, the Underwriters Laboratories, Inc. listing, to industry practice or otherwise, are not intended to provide all relevant information required for use and installation of our products. Refer to applicable codes, instructions and industry specifications prior to installation or use.

## Non-Metallic Sheathed Cable Fittings

### Suggested Specifications for Non-Metallic Sheathed Cable Fittings

- Where non-metallic sheathed cable or flexible cord terminates into a threaded or threadless opening, terminating fittings used shall be approved for the purpose by nationally recognized laboratory, inspection agency or product evaluation organization.
- Terminating fittings shall be of malleable iron, steel or thermoplastic construction designed to provide adequate strain relief and positively prevent damage to jacket or conductor insulation such as series 3300 or 3302M manufactured by Thomas & Betts.
- Ferrous metal fittings shall be electro zinc plated inside/ outside including threads and bushed with a nylon insulated throat.
- Thermoplastic material used for connector construction shall be of high impact strength suitable for 105° C/ 221° F service with a UL flammability rating of 94V-1.
- Where non-metallic sheathed cable passes through either factory or field punched, cut or drilled holes in metallic members, the cable shall be protected by thermoplastic bushing such as series 3210 manufactured by Thomas & Betts. Bushing shall be firmly secured in opening. Nylon bushed metallic fittings such as Thomas & Betts series 1942 may be substituted as required.

**Series 3300**  
Non-Metallic Sheathed  
Cable and Flexible Cord  
Connectors (All Plastic)



**Series 3302M**  
Non-Metallic Sheathed Cable and  
Flexible Cord Connectors (Steel)



**Series 3210**  
Knockout Bushings



**Series 1942**  
Insulated Nipples

## Non-Metallic Sheathed Cable Fittings

### Non-Metallic Sheathed Cable and Flexible Cord Connectors (All Plastic)

#### Application

- To connect non-metallic sheathed cable and flexible cord to a box or an enclosure

#### Features

- Design provides strain relief by partially deflecting cable (A); therefore:
  - Connector will not damage outer covering or jacket of cable, or conductor insulation; designed to give safe trouble free installation
  - Holding power and cable strain relief are not affected by surface finish of outer covering or cable jacket
  - Connector provides superior holding power far in excess of listing agency requirements
- Snap-in one-piece design; accommodates variation in knockout dimensions, saves installation time (B).
- All high-impact thermoplastic construction provides:
  - Insulated throat; conductors are protected from abrasion
  - Improved dielectric strength, and eliminates potential shorts
  - Corrosion resistance
- Wide range — reduces inventories
- Connector may be pre-installed in box K.O. or on cable

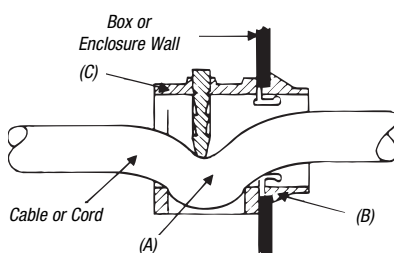

#### Typical Installation

|   |  |   |
|---|--|---|
| <p>1. Remove sheath from end of cable (4" or more as required). Insert cable through connector as shown (Cable under button).</p> | <p>2. Insert button into cavity.</p>                 | <p>3. With grooved pliers or parallel jaw type pliers (commercially available), squeeze button into cord wires as far into connector body as possible.<br/><b>Note:</b> It may be necessary to re-adjust pliers to ensure button is properly installed.</p> |
| <p>4. Snap connector into knockout box. If desired, this step can be done prior to Step 1.</p>                                    | <p>5. To remove from knockout box, depress ears.</p> | <p>6. To remove from cable, cut connector as shown.</p>   |

#### Range

| CAT. NO.    | CABLE/KNOCKOUT SIZE | CORD RANGE  |
|-------------|---------------------|---|
| 3300        | 1/2"                | #10-2, #12-2 & #14-2 Type NM Cable; .125" to .300" outside diameter cord  |
| 3201 & 3350 | 1/2"                | #10-3, #12-3, #14-3, #10-2, #12-2, #14-2 Type NM Cable; also multiple (2) #12-2 and #14-2 Type NM Cable; .300" to .600" outside diameter cord |
| 3202        | 3/4"                | #8-3 and #6-3 type NM cables; also Multiple (2) #14-3 and #10-2 Type NM Cable; .500" to .850" outside diameter cord                           |

#### Standard Material

All high-impact polycarbonate — UL Class 94V-1 suitable for 105° C application

#### Standard Finish

As molded (Black)

#### Listings/Compliances

UL (UL File No: E-23017)

CSA (Cat. #3201, 3350) for factory installation (LR-589, LR-2884)

UL 514B

CSA C22.2 #18 (Where applicable)

ANSI C33.84, NFPA 70

## Non-Metallic Sheathed Cable Fittings

### Non-Metallic Sheathed Cable and Flexible Cord Connectors (Steel)

#### Application

- To connect non-metallic sheathed cable and flexible cord to a box or an enclosure

#### Features

- Rugged all-steel/malleable iron construction (A)
- Rounded cable clamp grip provides superior mechanical holding power without damaging conductor insulation or outer jacket (B)
- Clamp designed to cover body opening for a neat and safe installation
- Screws thread into clamp and not body; screw heads are snug with body and ends of screws do not project beyond the body (C)
- Insulator firmly secured in place protects conductors and reduces wire pulling effort; protects threads from damaging during handling (D)
- Locknut designed to secure connector to a box or enclosure; will not vibrate loose

#### Standard Material

Body . . . . . ½" thru 1" Steel; 1¼" thru 2" Malleable Iron  
 Clamp . . . . . ½" thru 1¼" Steel; 1¼" thru 2" Malleable Iron  
 Locknut . . . . . All Steel  
 Insulator . . . . . Thermoplastic

#### Standard Finish

All steel and malleable iron parts —  
 Electro Zinc Plated & Chromate Coated

#### Range

Hub Size. . . . . ½" thru 2" Hubs  
 Provided with Straight Pipe Threads (NPS.)  
 Cable . . . . . (2) #14 thru (4) #4 Type NM  
 Cable Outside Diameter . . . . .250" to 1.150"

#### Listings/Compliances

UL (UL File No: E-23017)  
 CSA (LR-589, LR-2884)  
 UL 514B  
 CSA C22.2 No. 18  
 NFPA 70  
 NEMA FB1  
 Federal Standard H-28 (Threads)



**3302M Series**  
 Non-Metallic Sheathed Cable Connector

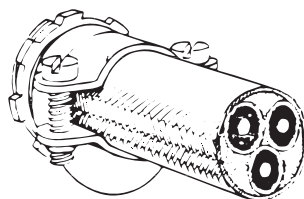
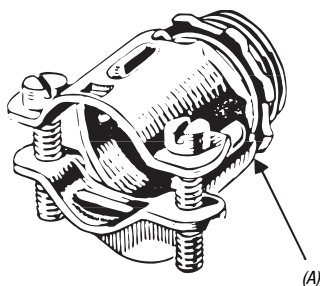
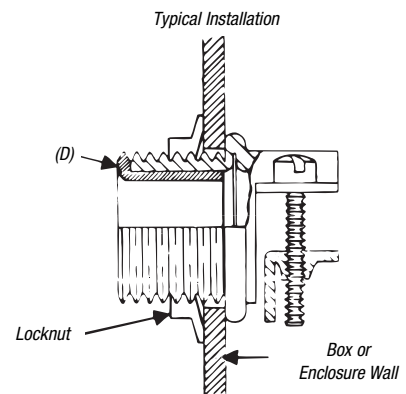

Typical Installation (Flexible Cord)

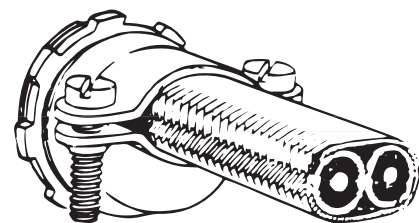

Typical Installation (NM-Sheathed Cable)

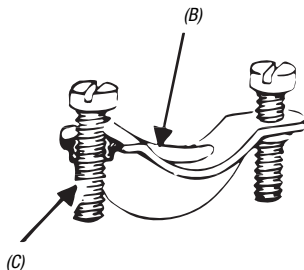



## Non-Metallic Sheathed Cable Fittings

Steel or malleable iron

### Two-Screw Connectors

Rounded cable grip and smooth bushing protect the cable sheath and wire insulation. Because saddle is threaded, screws do not travel or extend beyond the connector body as it is clamped to the cable. An extra lip on the saddle closes the unused part of the connector opening.

- Threaded saddle means screws don't travel or extend beyond connector body as it's clamped to cable
- Extra lip on saddle closes unused part of connector opening
- Steel or malleable iron construction
- Look for the unique T&B blue color ensuring the highest quality fitting

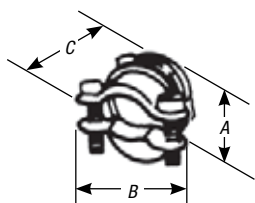

| NON-INSULATED<br>CAT. NO. | INSULATED<br>CAT. NO. | K.O.<br>SIZE | UL LISTED & CSA CERTIFIED                               |                                      | UL LISTED & CSA CERTIFIED   | IN.                        |         |         | INSULATED CABLE<br>OPENING (IN.) |       |
|---------------------------|-----------------------|--------------|---|--------------------------------------|---|----------------------------|---------|---------|----------------------------------|-------|
|                           |                       |              | SINGLE<br>NM & NMC CABLE                                | PAIRS OF<br>NM & NMC CABLE           |   | SERVICE<br>ENTRANCE CABLES | A       | B       | C                                | MAX.  |
| 3302-TB*                  | 3302M-TB              | 1/2"         | (2) #14, (2) #12, (2) #10,<br>(3) #14, (3) #12, (3) #10 | (2) #14, (2) #12                     | (2) #12 thru (2) #4, (3) #12, (3) #10   | 1                          | 1 13/32 | 1       | .590                             | .250  |
| 3303-TB                   | 3303M                 | 3/4"         | (2) #8, (2) #6, (3) #8,<br>(3) #6, (3) #4               | (2) #12, (2) #10,<br>(2) #8, (3) #14 | (2) #8 thru (2) 1/0, (3) #8, (3) #6,<br>(2) #6 + #8 GND,<br>(2) #1, (2) 1/0, (3) #6 thru (3) #2 | 1 1/4                      | 1 1/8   | 1 1/8   | .750                             | .530  |
| 3304                      | 3304M                 | 1"           | (3) #8, (3) #6, (3) #4                                  | (2) #8, (3) #10                      | (2) #4 + #6 GND, (2) #3 + #5<br>GND, (2) #2 + #4 GND<br>(3) #2 thru (3) 2/0, (2) #1 + #3 GND    | 1 1/2                      | 1 1/8   | 1 1/4   | .990                             | .690  |
| 3305                      | 3305M                 | 1 1/4"       | —   | (2) #8, (2) #6, (2) #4, (3) #8       | (2) 1/0 + #2 GND,<br>(2) 2/0 + #1 GND   | 1 29/32                    | 2 1/4   | 1 1/4   | 1.320                            | .850  |
| 3306                      | 3306M                 | 1 1/2"       | (3) #4, (3) #6  | —                                    | (3) 3/0, (3) 4/0, (2) 3/0 + 1/0<br>GND, (2) 4/0 + 2/0 GND                                       | 2 3/16                     | 2 5/8   | 1 1/16  | 1.530                            | .930  |
| 3307                      | 3307M                 | 2"           | Max. 1.98", Min. 1.15"                                  | Max. 1.98", Min. 1.15"               | —   | 2 3/4                      | 3 1/4   | 1 7/8   | —                                | —     |
| 3308†                     | —                     | 2 1/2"       | Max. 2.38", Min. 1.5"                                   | Max. 2.38", Min. 1.5"                | —   | 3 1/4                      | 3 15/16 | 2 3/16  | —                                | —     |
| 3309†                     | —                     | 3"           | Max. 2.88", Min. 1.75"                                  | Max. 2.88", Min. 1.75"               | —   | 3 13/16                    | 4 1/16  | 2 3/16  | 1.980                            | 1.150 |
| 3310†                     | —                     | 3 1/2"       | Max. 3.38", Min. 2.25"                                  | Max. 3.38", Min. 2.25"               | —   | 4 7/16                     | 5 1/4   | 2 27/32 | —                                | —     |
| 3311†                     | —                     | 4"           | Max. 3.88", Min. 2.5"                                   | Max. 3.88", Min. 2.5"                | —   | 4 7/8                      | 5 15/16 | 3 3/2   | —                                | —     |

\*UL Listed for use with rubber and thermoplastic flexible cords (both single and multiple cords and two oval cables).

UL Listed for multiple cords and cables.

CSA File No. 2884

UL File No. E-23013 – 1/2" – 1 1/2"; U.L. File No. E-15170 – 2"

† Not UL Listed or CSA certified.