

# thermOweld®

ECN 1521 REV "A" 2/12/96

THE ULTIMATE CONNECTION | A DIVISION OF CONTINENTAL® INDUSTRIES

## CADWELD® TO THERMOWELD® CROSS REFERENCE FOR CATHODIC PROTECTION

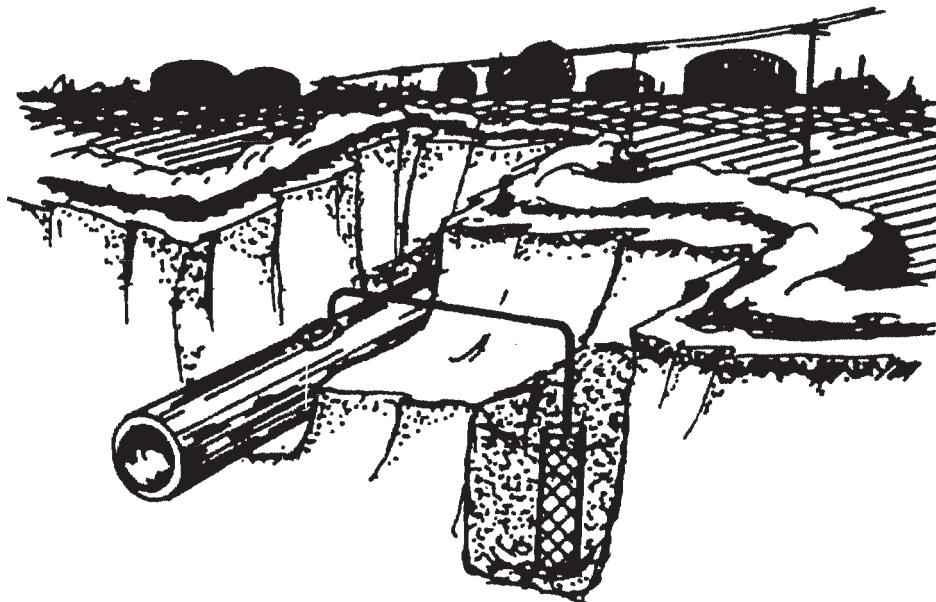
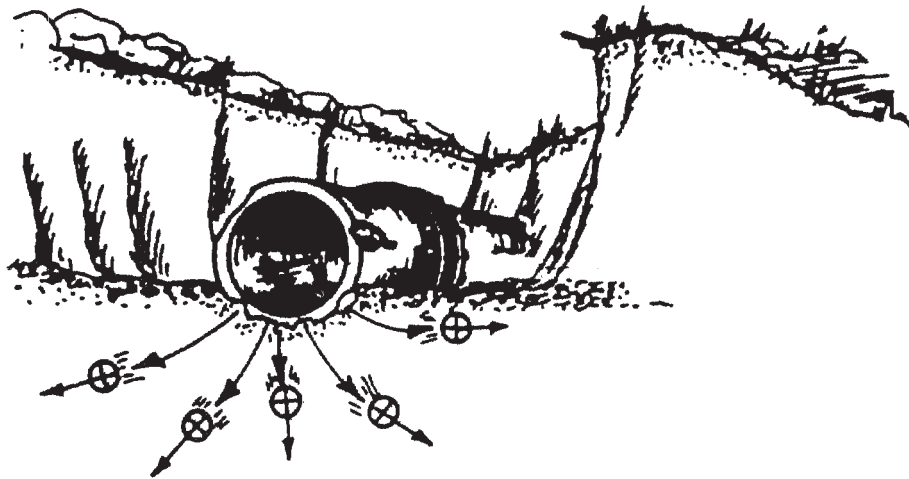

4102 SOUTH 74TH EAST AVENUE / P.O. BOX 994  
TULSA, OKLAHOMA 74101  
PHONE (918) 663-1440 FAX (918) 622-1275

CADWELD® IS A REGISTERED TRADEMARK OF ERICO®, INC.

# thermOweld® PROCESS

The THERMOWELD® cathodic connection process is a simple, efficient method of welding copper to copper or copper to steel. No outside source of power is required when using ThermOweld®. ThermOweld® connections use the high temperature of reaction of powdered copper oxide and aluminum. The reaction takes place in a semi-permanent graphite mold (THERMOMOLD) that last for fifty or more welds if properly cared for. The ThermOweld® reaction takes place in a very few seconds, therefore the total amount of heat (calories or BTU's) applied to the conductors or surfaces is considerably less than that employed in brazing or soldering. This is an important consideration when welding to insulated cable or thin wall pipe.

ThermOweld® is ideal for field use, since it is light and portable and requires no outside power source. It requires very little time or skill to obtain an efficient, maintenance free electrical connection when using ThermOweld®.

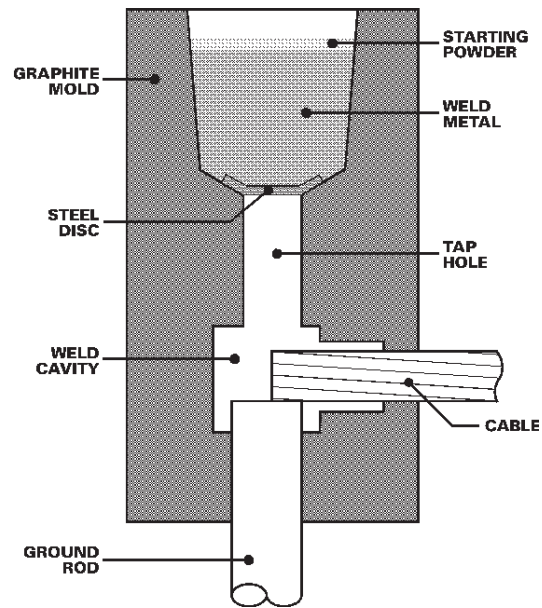

Cutaway Section of CR-1 Type Mold

## THERMOWELD® CONNECTION

The ThermOweld® connection is a molecular weld. The weld metal has the same melting point as copper. Because of these factors along with the increased cross section of the connection, ThermOweld® connections:

1. Will not be affected by a high current surge. Tests have shown that the electrical conductor will melt before the ThermOweld® connection when subjected to high short-

circuit current. Consult I.E.E.E. Standard 80-1989.

2. Will not loosen or corrode at the point of weld. There are no contact surfaces or mechanical pressures involved. A ThermOweld® connection becomes an integral part of the conductor.
3. Have a current-carrying capacity equal to or greater than that of the conductors.

ThermOweld® equipment has been used to weld materials other than copper for electrical purposes. Materials welded have included:

Stainless Steel	Monel	Copper Clad Steel	Steel Rail	Brass
Copperweld® <sup>1</sup>	Plain Steel	Bronze	Chromax	Nichrome
Nichrome V	Everdur® <sup>2</sup>	Galvanized Steel	Wrought Iron	Cast Iron
Kama	Cor-Ten® <sup>3</sup>	Silicone Bronze	Columbium	Niobium

<sup>1</sup> Copperweld® is a registered trademark of Copperweld Steel Co.

<sup>2</sup> Everdur® is a registered trademark of Anaconda Copper Co.

<sup>3</sup> Cor-Ten® is a registered trademark of United States Steel Corp.

## INDEX

CADWELD® TYPE	THERMOWELD® TYPE	PAGE #	CADWELD® TYPE	THERMOWELD® TYPE	PAGE #
CAGR .....	CR-1 .....	5	CAPC .....	CC-6 .....	4
CAGT .....	CR-2 .....	6	CASS .....	CC-1 .....	3
CAHA .....	CS-32 .....	7	CATA .....	CC-2 .....	3
CAHB .....	CS-33 .....	9	CAVH .....	CS-37 .....	12
CAHC .....	CS-34 .....	8	CAVS .....	CS-36 .....	11
CAHE .....	CS-35 .....	10	STRAP BONDS <sup>13</sup>		
CALA .....	CB-1 .....	12	ACCESSORIES <sup>14</sup>		

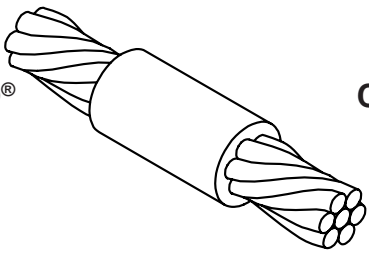
<b>THERMOWELD® TYPE CC-1</b>						<b>CADWELD® TYPE CASS</b>	
CABLE SIZE		STANDARD MOLDS					
RUN	TAP	CADWELD® MOLD #	THERMO MOLD # †	CART. SIZE	P K		
#12 Sol	#12 Sol	CASST-001	M-8224-S	15	18		
#10 Sol	#10 Sol	CASST-1A	M-8225-S	15	18		
#8 Sol	#8 Sol	CASST-1D	M-8228-S	15	18		
#6 Sol	#6 Sol	CASST-1G	M-8229-S	25	18		
#6 Str	#6 Str	CASST-1H	M-8229	25	18		
#4 Sol	#4 Sol	CASST-1K	M-8232-S	25	18		
#4 Str	#4 Str	CASST-1L	M-8232	25	18		
#2 Sol	#2 Sol	CASST-1T	M-8235-S	32	18		
#2 Str	#2 Str	CASST-1V	M-8235	32	18		
#1 Str	#1 Str	CASST-1Y	M-8239	32	18		
1/0 Str	1/0 Str	CASSP-2C	M-8242	45	19		
2/0 Str	2/0 Str	CASSP-2G	M-8244	65	19		

† Sold with handle clamps. If not required, specify MOLD NUMBER followed by suffix "-G".

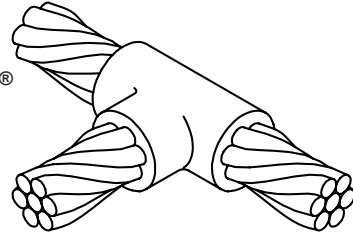
<b>THERMOWELD® TYPE CC-2</b>						<b>CADWELD® TYPE CATA</b>	
CABLE SIZE		STANDARD MOLDS					
RUN	TAP	CADWELD® MOLD #	THERMO MOLD # †	CART. SIZE	P K		
#2 Str	#2 Str	CATAN-1V1V	M-8245	45	20		
	#4 Str	CATAN-1V1L	M-8246	45	20		
#1 Str	#1 Str	CATAN-1Y1Y	M-8247	45	20		
	#2 Str	CATAN-1Y1V	M-8248	45	20		
	#4 Str	CATAN-1Y1L	M-8249	45	20		
1/0 Str	#1 Str	CATAN-2C1Y	M-8250	45	20		
	#2 Str	CATAN-2C1V	M-8251	45	20		
	#4 Str	CATAN-2C1L	M-8252	45	20		
2/0 Str	#1 Str	CATAN-2G1Y	M-8253	45	20		
	#2 Str	CATAN-2G1V	M-8256	45	20		
	#4 Str	CATAN-2G1L	M-8260	45	20		

† Sold with handle clamps. If not required, specify MOLD NUMBER followed by suffix "-G".

**THERMOWELD®  
TYPE  
CC-6**

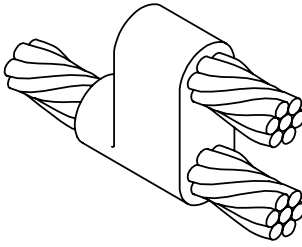

**CADWELD®  
TYPE  
CAPC**

CABLE SIZE		STANDARD MOLDS			
RUN	TAP	CADWELD® MOLD #	THERMO MOLD # †	CART. SIZE	P K
#6 Str	#6 Str	CAPCT-1H1H	M-8261	25	18
	#6 Sol	CAPCT-1H1G	M-8264	25	18
	#8 Str	CAPCT-1H1E	M-8265	25	18
	#8 Sol	CAPCT-1H1D	M-8266	25	18
#4 Str	#4 Str	CAPCT-1L1L	M-8267	32	18
	#6 Str	CAPCT-1L1H	M-8268	32	18
	#6 Sol	CAPCT-1L1G	M-8269	32	18
	#8 Str	CAPCT-1L1E	M-8274	32	18
	#8 Sol	CAPCT-1L1D	M-8275	32	18
#2 Str	#2 Str	CAPCP-1V1V	M-8276	65	19
	#4 Str	CAPCP-1V1L	M-8280	45	19
	#6 Str	CAPCT-1V1H	M-8281	32	18
	#6 Sol	CAPCT-1V1G	M-8283	32	18
	#8 Str	CAPCT-1V1E	M-8284	32	18
	#8 Sol	CAPCT-1V1D	M-8285	32	18
#1 Str	#2 Str	CAPCP-1Y1V	M-8286	65	19
	#4 Str	CAPCP-1Y1L	M-8287	45	19
	#6 Str	CAPCP-1Y1H	M-8288	45	19
	#6 Sol	CAPCP-1Y1G	M-8291	45	19
	#8 Str	CAPCP-1Y1E	M-8292	45	19
	#8 Sol	CAPCP-1Y1D	M-8293	45	19
1/0 Str	#2 Str	CAPCP-2C1V	M-8295	65	19
	#4 Str	CAPCP-2C1L	M-8297	65	19
	#6 Str	CAPCP-2C1H	M-8299	45	19
	#6 Sol	CAPCP-2C1G	M-8300	45	19
	#8 Str	CAPCP-2C1E	M-8301	45	19
	#8 Sol	CAPCP-2C1D	M-8304	45	19
2/0 Str	#2 Str	CAPCN-2G1V	M-8306	2-45	20
	#4 Str	CAPCP-2G1L	M-8307	65	19
	#6 Str	CAPCP-2G1H	M-8310	65	19
	#6 Sol	CAPCP-2G1G	M-8311	65	19
	#8 Str	CAPCP-2G1E	M-8313	65	19
	#8 Sol	CAPCP-2G1D	M-8316	65	19

† Sold with handle clamps. If not required, specify MOLD NUMBER followed by suffix "-G".

**THERMOWELD®  
TYPE CR-1**

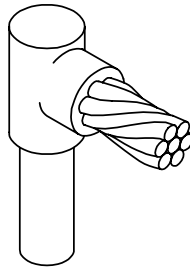

**CADWELD®  
TYPE CAGR**

GROUND ROD & CABLE		STANDARD MOLDS			
GRD ROD SIZE	CABLE SIZE	CADWELD® MOLD #	THERMO MOLD # †	CART. SIZE	P K
1/2"	#6 Sol◆	CAGRT-151G	M-1960-S	25	18
	#6 Str	CAGRT-151H	M-1960	25	18
	#4 Sol	CAGRT-151K	M-1961-S	25	18
	#4 Str	CAGRT-151L	M-1961	25	18
	#2 Sol	CAGRT-151T	M-1962-S	32	18
	#2 Str	CAGRT-151V	M-1962	32	18
	#1 Str	CAGRP-151Y	M-1963	45	19
	1/0 Str	CAGRP-152C	M-1964	65	19
	2/0 Str	CAGRP-152G	M-1965	65	19
5/8"	#6 Sol◆	CAGRT-161G	M-1968-S	32	18
	#6 Str	CAGRT-161H	M-1968	32	18
	#4 Sol	CAGRT-161K	M-1969-S	32	18
	#4 Str	CAGRT-161L	M-1969	32	18
	#2 Sol	CAGRP-161T	M-1970-S	45	19
	#2 Str	CAGRP-161V	M-1970	45	19
	#1 Str	CAGRP-161Y	M-1971	45	19
	1/0 Str	CAGRP-162C	M-1972	65	19
	2/0 Str	CAGRP-162G	M-1973	65	19
3/4"	#6 Sol◆	CAGRT-181G	M-1976-S	32	18
	#6 Str	CAGRT-181H	M-1976	32	18
	#4 Sol	CAGRP-181K	M-1977-S	45	19
	#4 Str	CAGRP-181L	M-1977	45	19
	#2 Sol	CAGRP-181T	M-1978-S	45	19
	#2 Str	CAGRP-181V	M-1978	45	19
	#1 Str	CAGRP-181Y	M-1979	45	19
	1/0 Str	CAGRP-182C	M-1980	65	19
	2/0 Str	CAGRP-182G	M-1981	65	19

† Sold with handle clamps. If not required, specify MOLD NUMBER followed by suffix "-G".

◆ For wire size #14 to #10 solid, order (1) 38-0200-00 sleeve per weld.

**THERMOWELD®  
TYPE CR-2**

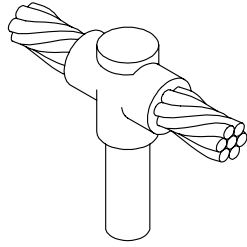

**CADWELD®  
TYPE CAGT**

GROUND ROD & CABLE		STANDARD MOLDS			
GRD ROD SIZE	CABLE SIZE	CADWELD® MOLD #	THERMO MOLD # †	CART. SIZE	P K
1/2"	#6 Sol◆	CAGTT-151G	M-1984-S	32	18
	#6 Str	CAGTT-151H	M-1984	32	18
	#4 Sol	CAGTT-151K	M-1985-S	32	18
	#4 Str	CAGTT-151L	M-1985	32	18
	#2 Sol	CAGTP-151T	M-1986-S	45	19
	#2 Str	CAGTP-151V	M-1986	45	19
	#1 Str	CAGTP-151Y	M-1987	65	19
	1/0 Str	CAGTP-152C	M-1988	65	19
	2/0 Str	CAGTP-152G	M-1989	65	19
	5/8"	#6 Sol◆	CAGTP-161G	M-1992-S	45
#6 Str		CAGTP-161H	M-1992	45	19
#4 Sol		CAGTP-161K	M-1993-S	65	19
#4 Str		CAGTP-161L	M-1993	65	19
#2 Sol		CAGTP-161T	M-1994-S	65	19
#2 Str		CAGTP-161V	M-1994	65	19
#1 Str		CAGTP-161Y	M-1995	65	19
1/0 Str		CAGTN-162C	M-1996	2-45	20
2/0 Str		CAGTN-162G	M-1997	2-45	20
3/4"		#6 Sol◆	CAGTP-181G	M-2000-S	45
	#6 Str	CAGTP-181H	M-2000	45	19
	#4 Sol	CAGTP-181K	M-2001-S	65	19
	#4 Str	CAGTP-181L	M-2001	65	19
	#2 Sol	CAGTP-181T	M-2002-S	65	19
	#2 Str	CAGTP-181V	M-2002	65	19
	#1 Str	CAGTP-181Y	M-2003	65	19
	1/0 Str	CAGTN-182C	M-2004	2-45	20
	2/0 Str	CAGTN-182G	M-2005	2-45	20

† Sold with handle clamps. If not required, specify MOLD NUMBER followed by suffix "-G".

◆ For wire size #14 to #10 solid, order (2) 38-0200-00 sleeve per weld.

**THERMOWELD®  
TYPE  
CS-32**

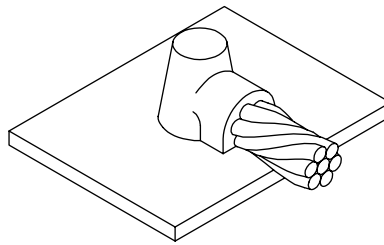

**CADWELD®  
TYPE  
CAHA**

CABLE SIZE	SURFACE	STANDARD MOLDS			
		CADWELD® MOLD #	THERMO MOLD # †	CART. SIZE	P K
#6 Sol ♦	Flat (4" & larger pipe) 3/4" to 3 1/2"	CAHAA-1G	M-100	15	2
		CAHAA-1GA	M-101	15	3
#6 Str	Flat (4" & larger pipe) 3/4" to 3 1/2" pipe	CAHAA-1H	M-102	15	2
		CAHAA-1HA	M-103	15	3
#4 Sol	Flat (6" & larger pipe) 3/4" to 3 1/2" pipe 4" to 5" pipe	CAHAA-1K	M-104	15	2
		CAHAA-1KA	M-105	15	3
		CAHAA-1KB	M-130	15	3
#4 Str	Flat (6" & larger pipe) 3/4" to 3 1/2" pipe 4" to 5" pipe	CAHAA-1L	M-106	15	2
		CAHAA-1LA	M-107	15	3
		CAHAA-1LB	M-108	15	3
#2 Sol	Flat (10" & larger pipe) 1" to 3 1/2" pipe 4" to 8" pipe	CAHAA-1T	M-109	25	3
		CAHAA-1TA	M-110	25	3
		CAHAA-1TB	M-111	25	3
#2 Str	Flat (16" & larger pipe) 1" to 3 1/2" pipe 4" to 8" pipe 10" to 14" pipe	CAHAA-1V	M-112	32	3
		CAHAA-1VA	M-113	32	3
		CAHAA-1VB	M-114	32	3
		CAHAA-1VC	M-115	32	3
#1 Str	Flat (16" & larger pipe) 1 1/2" to 3 1/2" pipe 4" to 8" pipe 10" to 14" pipe	CAHAA-1Y	M-116	45	3
		CAHAA-1YA	M-117	45	3
		CAHAA-1YB	M-118	45	3
		CAHAA-1YC	M-119	45	3
1/0 Str	Flat (20" & larger pipe) 2 1/2" to 3 1/2" pipe 4" to 8" pipe 10" to 18" pipe	CAHAA-2C	M-120	65	3
		CAHAA-2CA	M-121	65	3
		CAHAA-2CB	M-122	65	3
		CAHAA-2CC	M-123	65	3
2/0 Str	Flat (20" & larger pipe) 2 1/2" to 3 1/2" pipe 4" to 8" pipe 10" to 18" pipe	CAHAA-2G	M-124	65	3
		CAHAA-2GA	M-125	65	3
		CAHAA-2GB	M-126	65	3
		CAHAA-2GC	M-127	65	3

† Sold with frame. If not required, specify MOLD NUMBER followed by suffix "-G".

♦ For wire size #14 to #10 solid, order (1) 38-0200-00 sleeve per weld.



**THERMOWELD®  
TYPE  
CS-34**

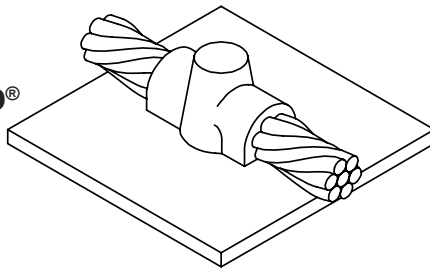

**CADWELD®  
TYPE  
CAHC**

CABLE SIZE	SURFACE	STANDARD MOLDS			
		CADWELD® MOLD #	THERMO MOLD # †	CART. SIZE	P K
#6 Sol◆	Flat (12" & larger pipe)	CAHCA-1G	M-1955	25	3
	3/4" to 2" pipe	CAHCA-1GA	M-5666	25	3
	2 1/2" to 5" pipe	CAHCA-1GB	M-3097	25	3
	6" to 10" pipe	CAHCA-1GC	M-3141	25	3
#6 Str	Flat (12" & larger pipe)	CAHCA-1H	M-5661	25	3
	3/4" to 2" pipe	CAHCA-1HA	M-5662	25	3
	2 1/2" to 5" pipe	CAHCA-1HB	M-5663	25	3
	6" to 10" pipe	CAHCA-1HC	M-5664	25	3
#4 Sol	Flat (12" & larger pipe)	CAHCA-1K	M-1956	25	3
	3/4" to 2" pipe	CAHCA-1KA	M-1957	25	3
	2 1/2" to 5" pipe	CAHCA-1KB	M-1958	25	3
	6" to 10" pipe	CAHCA-1KC	M-1966	25	3
#4 Str	Flat (12" & larger pipe)	CAHCA-1L	M-6000	25	3
	3/4" to 2" pipe	CAHCA-1LA	M-1967	25	3
	2 1/2" to 5" pipe	CAHCA-1LB	M-5501	25	3
	6" to 10" pipe	CAHCA-1LC	M-5503	25	3
#2 Sol	Flat (14" & larger pipe)	CAHCA-1T	M-5505	32	3
	2" to 3 1/2" pipe	CAHCA-1TA	M-5507	32	3
	4" to 6" pipe	CAHCA-1TB	M-5510	32	3
	8" to 10" pipe	CAHCA-1TC	M-5514	32	3
#2 Str	Flat (18" & larger pipe)	CAHCA-1V	M-5518	45	3
	2" to 3 1/2" pipe	CAHCA-1VA	M-5986	45	3
	4" to 8" pipe	CAHCA-1VB	M-5605	45	3
	10" to 16" pipe	CAHCA-1VC	M-5988	45	3
#1 Str	Flat (18" & larger pipe)	CAHCA-1Y	M-5519	45	3
	2" to 3 1/2" pipe	CAHCA-1YA	M-5520	45	3
	4" to 8" pipe	CAHCA-1YB	M-5521	45	3
	10" to 16" pipe	CAHCA-1YC	M-5523	45	3
1/0 Str	Flat (30" & larger pipe)	CAHCA-2C	M-5524	65	3
	3" to 4" pipe	CAHCA-2CA	M-5525	65	3
	5" to 6" pipe	CAHCA-2CB	M-5526	65	3
	8" to 10" pipe	CAHCA-2CC	M-5527	65	3
	12" to 28" pipe	CAHCA-2CD	M-5529	65	3
2/0 Str	Flat (30" & larger pipe)	CAHCA-2G	M-6251	65	3
	3" to 4" pipe	CAHCA-2GA	M-5530	65	3
	5" to 6" pipe	CAHCA-2GB	M-5531	65	3
	8" to 10" pipe	CAHCA-2GC	M-5532	65	3
	12" to 28" pipe	CAHCA-2GD	M-5533	65	3

† Sold with frame. If not required, specify MOLD NUMBER followed by suffix "-G".

◆ For wire size #14 to #10 solid, order (2) 38-0200-00 sleeve per weld.



**THERMOWELD®  
TYPE  
CS-33**

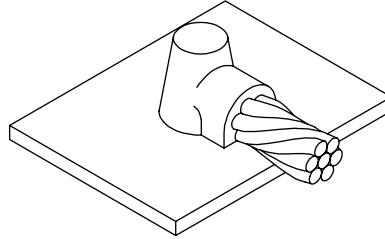

**CADWELD®  
TYPE  
CAHB**

CABLE SIZE	SURFACE	STANDARD MOLDS			
		CADWELD® MOLD #	THERMO MOLD # †	CART. SIZE	P K
#6 Sol◆	Flat (30" & larger pipe) 4" to 24" pipe	CAHBA-1G	M-156	25CI	3
		CAHBA-1G-P.S.*	M-156-P.S.*	25CI	3
#6 Str	Flat (30" & larger pipe) 4" to 24" pipe	CAHBA-1H	M-157	25CI	3
		CAHBA-1H-P.S.*	M-157-P.S.*	25CI	3
#4 Sol	Flat (30" & larger pipe) 4" to 24" pipe	CAHBA-1K	M-158	45CI	3
		CAHBA-1K-P.S.*	M-158-P.S.*	45CI	3
#4 Str	Flat (30" & larger pipe) 4" to 24" pipe	CAHBA-1L	M-159	45CI	3
		CAHBA-1L-P.S.*	M-159-P.S.*	45CI	3
#2 Sol	Flat (30" & larger pipe) 4" to 24" pipe	CAHBA-1T	M-160	45CI	3
		CAHBA-1T-P.S.*	M-160-P.S.*	45CI	3
#2 Str	Flat (30" & larger pipe) 4" to 24" pipe	CAHBA-1V	M-161	45CI	3
		CAHBA-1V-P.S.*	M-161-P.S.*	45CI	3
#1 Str	Flat (30" & larger pipe) 4" to 24" pipe	CAHBA-1Y	M-163	65CI	3
		CAHBA-1Y-P.S.*	M-163-P.S.*	65CI	3

† Sold with frame. If not required, specify MOLD NUMBER followed by suffix "-G".

◆ For wire size #14 to #10 solid, order (1) 38-0200-00 sleeve per weld.

P.S. = Specify pipe size.

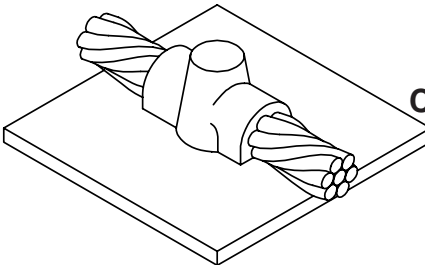
					
CABLE SIZE	SURFACE	STANDARD MOLDS			
		CADWELD® MOLD #	THERMO MOLD # †	CART. SIZE	P K
#6 Sol◆	Flat (30" & larger pipe) 4" to 24" pipe	CAHEA-1G	M-5316	32CI	3
		CAHEA-1G-P.S.*	M-5316-P.S.*	32CI	3
#6 Str	Flat (30" & larger pipe) 4" to 24" pipe	CAHEA-1H	M-5535	32CI	3
		CAHEA-1H-P.S.*	M-5535-P.S.*	32CI	3
#4 Sol	Flat (30" & larger pipe) 4" to 24" pipe	CAHEA-1K	M-5536	45CI	3
		CAHEA-1K-P.S.*	M-5536-P.S.*	45CI	3
#4 Str	Flat (30" & larger pipe) 4" to 24" pipe	CAHEA-1L	M-5537	45CI	3
		CAHEA-1L-P.S.*	M-5537-P.S.*	45CI	3
#2 Sol	Flat (30" & larger pipe) 4" to 24" pipe	CAHEA-1T	M-5538	45CI	3
		CAHEA-1T-P.S.*	M-5538-P.S.*	45CI	3
#2 Str	Flat (30" & larger pipe) 4" to 24" pipe	CAHEA-1V	M-5540	45CI	3
		CAHEA-1V-P.S.*	M-5540-P.S.*	45CI	3
#1 Str	Flat (30" & larger pipe) 4" to 24" pipe	CAHEA-1Y	M-5542	65CI	3
		CAHEA-1Y-P.S.*	M-5542-P.S.*	65CI	3

† Sold with frame. If not required, specify MOLD NUMBER followed by suffix "-G".

◆ For wire size #14 to #10 solid, order (2) 38-0200-00 sleeve per weld.

P.S. = Specify pipe size.

**THERMOWELD®  
TYPE  
CS-36**

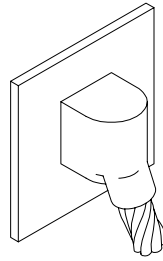

**CADWELD®  
TYPE  
CAVS**

CABLE SIZE	SURFACE	STANDARD MOLDS			
		CADWELD® MOLD #	THERMO MOLD # †	CART. SIZE	P K
#6 Sol◆	Flat (12" & larger pipe) 3/4" to 3-1/2" pipe 4" to 10" pipe	CAVST-1G	M-142	15	18
		CAVST-1GA	M-150	15	18
		CAVST-1GB	M-151	15	18
#6 Str	Flat (12" & larger pipe) 3/4" to 3-1/2" pipe 4" to 10" pipe	CAVST-1H	M-144	15	18
		CAVST-1HA	M-152	15	18
		CAVST-1HB	M-153	15	18
#4 Sol	Flat (12" & larger pipe) 3/4" to 1-1/2" pipe 2" to 4" pipe 5" to 10" pipe	CAVST-1K	M-145	25	18
		CAVST-1KA	M-186	25	18
		CAVST-1KB	M-187	25	18
		CAVST-1KC	M-188	25	18
#4 Str	Flat (12" & larger pipe) 3/4" to 3-1/2" pipe 2" to 4" pipe 5" to 10" pipe	CAVST-1L	M-146	25	18
		CAVST-1LA	M-189	25	18
		CAVST-1LB	M-190	25	18
		CAVST-1LC	M-191	25	18
#2 Sol	Flat (14" & larger pipe) 1" to 1-1/2" pipe 2" to 4" pipe 5" to 12" pipe	CAVST-1T	M-147	25	18
		CAVST-1TA	M-192	25	18
		CAVST-1TB	M-193	25	18
		CAVST-1TC	M-194	25	18
#2 Str	Flat (14" & larger pipe) 1" to 1-1/2" pipe 2" to 3" pipe 4" to 6" pipe 8" to 12" pipe	CAVST-1V	M-148	32	18
		CAVST-1VA	M-195	32	18
		CAVST-1VB	M-196	32	18
		CAVST-1VC	M-197	32	18
		CAVST-1VD	M-198	32	18
#1 Str	Flat (18" & larger pipe) 1-1/2" to 2-1/2" pipe 3" to 4" pipe 5" to 10" pipe 12" to 16" pipe	CAVSP-1Y	M-6117	45	19
		CAVSP-1YA	M-6118	45	19
		CAVSP-1YB	M-6119	45	19
		CAVSP-1YC	M-6120	45	19
		CAVSP-1YD	M-6121	45	19
1/0 Str	Flat (18" & larger pipe) 2-1/2" to 4" pipe 5" to 10" pipe 12" to 16" pipe	CAVSP-2C	M-2586	65	19
		CAVSP-2CA	M-2587	65	19
		CAVSP-2CB	M-2588	65	19
		CAVSP-2CC	M-2589	65	19
2/0 Str	Flat (18" & larger pipe) 3" to 4" pipe 5" to 10" pipe 12" to 16" pipe	CAVSP-2G	M-2590	65	19
		CAVSP-2GA	M-2591	65	19
		CAVSP-2GB	M-2592	65	19
		CAVSP-2GC	M-2953	65	19

† Sold with handle clamps. If not required, specify MOLD NUMBER followed by suffix "-G".

◆ For wire size #14 to #10 solid, order (1) 38-0200-00 sleeve per weld.

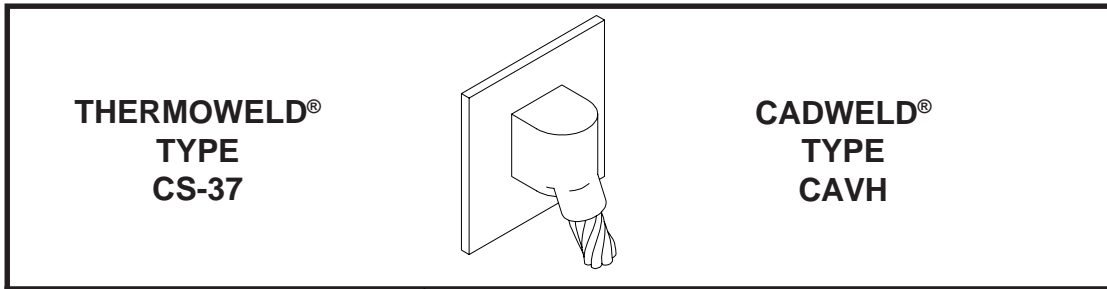

CABLE SIZE	SURFACE	STANDARD MOLDS			
		CADWELD® MOLD #	THERMO MOLD # †	CART. SIZE	P K
#6 Sol◆	Flat (30" & Larger Pipe) 4" to 24" pipe	CAVHT-1G	M-2594-S	25CI	18
		CAVHT-1G-P.S.*	M-2594-S-P.S.*	25CI	18
#6 Str	Flat (30" & Larger Pipe) 4" to 24" pipe	CAVHT-1H	M-2594	25CI	18
		CAVHT-1H-P.S.*	M-2594-P.S.*	25CI	18
#4 Sol	Flat (30" & Larger Pipe) 4" to 24" pipe	CAVHT-1K	M-2595-S	32CI	18
		CAVHT-1K-P.S.*	M-2595-S-P.S.*	32CI	18
#4 Str	Flat (30" & Larger Pipe) 4" to 24" pipe	CAVHT-1L	M-2595	32CI	18
		CAVHT-1L-P.S.*	M-2595-P.S.*	32CI	18
#2 Sol	Flat (30" & Larger Pipe) 4" to 24" pipe	CAVHP-1T	M-2596-S	45CI	19
		CAVHP-1T-P.S.*	M-2596-S-P.S.*	45CI	19
#2 Str	Flat (30" & Larger Pipe) 4" to 24" pipe	CAVHP-1V	M-2596	45CI	19
		CAVHP-1V-P.S.*	M-2596-P.S.*	45CI	19
#1 Str	Flat (36" & Larger Pipe) 4" to 30" pipe	CAVHP-1Y	M-2597	65CI	19
		CAVHP-1Y-P.S.*	M-2597-P.S.*	65CI	19

† Sold with handle clamps. If not required, specify MOLD NUMBER followed by suffix "-G".

◆ For wire size #14 to #10 solid, order (1) 38-0200-00 sleeve per weld.

P.S. = Specify pipe size.

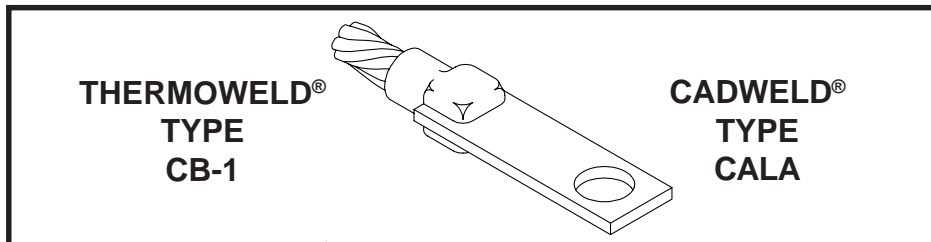

CABLE & LUG SIZE		STANDARD MOLDS			
CABLE	LUG▼	CADWELD® MOLD #	THERMO MOLD # †	CART. SIZE	P K
#6 Sol◆	1/16 X 1/2	CALAT-1G	M-8391-S	25	18
#6 Str▲	1/16 X 1/2	CALAT-1H	M-8391	25	18
#4 Sol	1/16 X 1/2	CALAT-1K	M-8393-S	25	18
#4 Str	1/16 X 1/2	CALAT-1L	M-8393	25	18
#2 Sol	1/16 X 1/2	CALAT-1T	M-8395-S	32	18
#2 Str	1/16 X 1/2	CALAT-1V	M-8395	32	18
#1 Str	1/16 X 1/2	CALAT-1Y	M-8397	32	18
1/0 Str	1/16 X 1/2	CALAP-2C	M-8398	45	19
2/0 Str	1/8 X 1	CALAP-2G	M-8399	45	19

† Sold with handle clamps. If not required, specify MOLD NUMBER followed by suffix "-G".

◆ Requires (1) 38-0201-00 sleeve per weld.

▲ Requires (1) 38-0202-00 sleeve per weld.

▼ Lug part number: 1/16"x1/2" 38-4709-00

1/8"x1" 38-4200-00

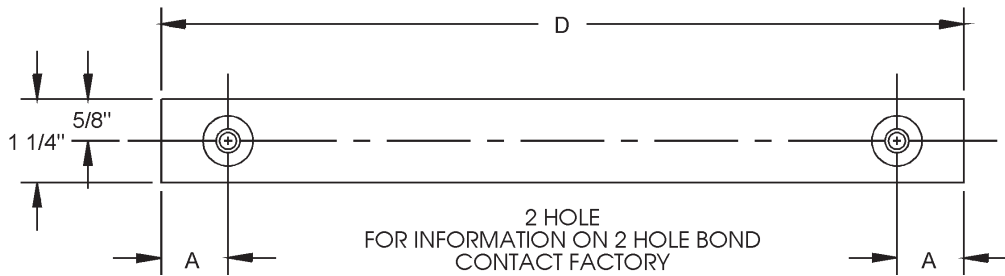
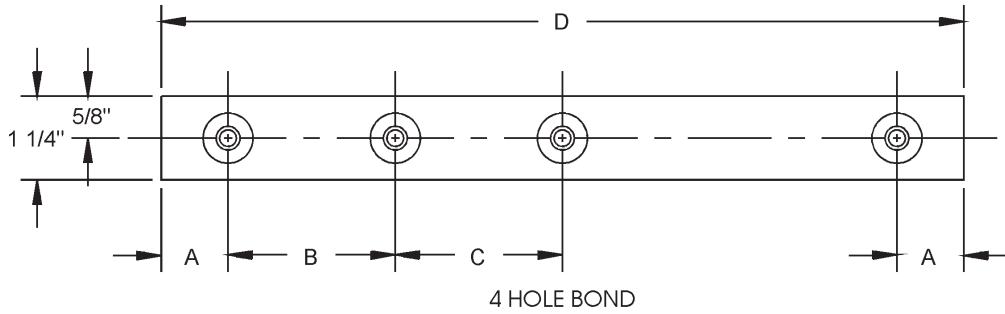
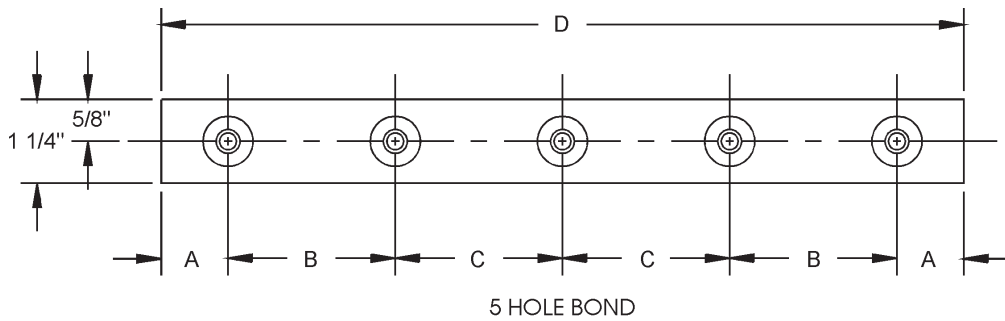

COPPER STRAP BONDS						
COUPLING SIZE	CATALOG NO.	# OF HOLES	A	B	C	D
5" & LARGER PIPE STYLE 38	# 27-0180-00	4	1"	3 3/4"	5 1/4"	20"
5" & LARGER PIPE STYLE 38	# 27-0181-00	4	1"	3 3/4"	6 1/4"	22"
5" & LARGER PIPE STYLE 38	# 27-0182-00	5	1"	3 3/4"	5 1/4"	20"
5" & LARGER PIPE STYLE 38	# 27-0183-00	5	1"	3 3/4"	6 1/4"	22"
UNDER 5" & LIGHT PATTERN STYLE 38	# 27-0184-00	4	1"	3 1/4"	4 1/4"	17"
UNDER 5" & LIGHT PATTERN STYLE 38	# 27-0185-00	4	1"	3 1/4"	5 1/4"	19"
UNDER 5" & LIGHT PATTERN STYLE 38	# 27-0186-00	5	1"	3 1/4"	4 1/4"	17"
UNDER 5" & LIGHT PATTERN STYLE 38	# 27-0187-00	5	1"	3 1/4"	5 1/4"	19"
FOR ALL STYLE 40 COUPLINGS USE (2) 27-0188-00 BONDS	# 27-0188-00	3	1"	3 3/4"	--	9 1/2"

CURRENT CAPACITY OF THE COPPER STRAP BONDS IS EQUIVALENT TO 1/0 STR COPPER CABLE

USE MOLD M-128 TO ATTACH BONDS WITH #15 CART.

# ACCESSORIES

CAB-112 ..... 38-0202-00 ..... COPPER ADAPTER SLEEVE  
CAB-133-1H .... 38-0200-00 ..... COPPER ADAPTER SLEEVE  
CAB-133-1K .... 38-0208-00 ..... COPPER ADAPTER SLEEVE  
CAB-133-1L ..... 38-0201-00 ..... COPPER ADAPTER SLEEVE  
CAB-136-A ..... 40-0319-03 ..... MOLD CLEANER  
CAB-140-A ..... 38-0329-00 ..... COPPER SHIM STOCK  
CAB-319 ..... 40-0141-00 ..... VERTICAL PIPE CLAMP FOR PK-18, 19 & 20 MOLDS  
CAB-320 ..... 40-4042-00 ..... HORIZONTAL CHAIN CLAMP FOR PK-3 MOLDS  
CAB-321-15 .... 40-0904-03 ..... EXTENSION WITH FLINT GUN (15")  
CAB-321-36 .... 40-0904-00 ..... EXTENSION WITH FLINT GUN (36")  
CAB-322 ..... N/A..... LEAD HOLDING CLIP - FITS ALL PRICE KEY 3 MOLDS  
CAD-03..... 38-0312-00 ..... HAMMER DIE  
CAD-05..... 38-0311-00 ..... HAMMER DIE  
CAD-09..... 38-0310-00 ..... HAMMER DIE  
CAT-111 ..... 38-4391-01 ..... SELF IGNITING TORCH HEAD  
CAT-305 ..... 38-0308-00 ..... SCREWDRIVER  
CAT-313 ..... 38-0306-00 ..... CARD CLOTH BRUSH  
CAT-317 ..... 38-4129-00 ..... PACKING MATERIAL 1lb PACKAGE  
CAT-317-A ..... 38-4129-05 ..... PACKING MATERIAL 5lb PACKAGE  
CAT-320 ..... 38-0309-00 ..... FLINT IGNITER  
CAT-320-A ..... 38-0309-01 ..... REPLACEMENT FLINTS FOR 38-0309-00  
CAT-321 ..... 38-0101-00 ..... RASP  
CAT-321-A ..... 38-0101-01 ..... REPLACEMENT BLADE FOR 38-0101-00 RASP  
CAT-328 ..... N/A..... DISK CONTAINER  
CAT-329 ..... 38-0304-00 ..... FILE AND HANDLE  
CAT-335 ..... 38-0307-00 ..... CRIMPING TOOL  
CAT-336 ..... 38-0305-00 ..... WIRE BRUSH  
CAT-337 ..... 38-0302-00 ..... TOOL BOX COMPLETE WITH TOOLS  
CAT-338 ..... N/A..... TOOL BOX ONLY  
CAT-343 ..... N/A..... TOOL BOX COMPLETE WITH TOOLS  
CAT-396 ..... N/A..... TOOL BOX ONLY