

PROCESS AUTOMATION



5500 SERIES

Installation Manual Purge and Pressurization System



BEBCO EPS®

PEPPERL+FUCHS
PROTECTING YOUR PROCESS



Contents

1. Preface	4
2. Information on these operating instructions	4
3. Responsibility of the operator and/or installer	4
4. General information on the ignition protection class - pressurizing system	5
4.1 Conditions of Safe Use	5
5. The 5500 Purge and Pressurization System	6
5.1 5500 Control Unit	6
5.1.1 Technical Specifications	7
5.1.2 Electrical Connections	10
5.1.3 Dimensions	11
5.1.4 Hardware Kit	14
5.1.5 Mounting of the Internal Control Unit	15
5.1.6 Mounting of the External Control Unit	16
5.2 EPV-5500 Vents	17
5.2.1 Technical Specification	17
5.2.2 Flow Rate Curves	18
5.2.3 Dimensions	22
5.3 Manifold Valves	23
5.3.1 Technical Specifications	24
5.3.2 Dimensions	26
6. Installation and Operation of the 5500 System	28
6.1 For Gas Atmospheres	28
6.2 For Dust Atmospheres	28
7. Programming the 5500 control unit	30
7.1 LED Indication	30
7.1.1 Buttons	31
7.2 The Purge Programming Settings	34
7.2.1 Program 1	34
7.2.2 Program 2	35
7.2.3 Program 3	36
7.2.4 Program 4	36
7.2.5 Program 5	37
7.3 Purging Timer	38
7.4 Minimum enclosure pressure 'P1'	39
7.5 Alarm pressure 'P2'	39
7.6 Purging pressure 'P3'	39
7.7 Maximum internal pressure 'P4'	40
7.8 4.8 Programming K2	42
7.9 Shutdown timer for K1	44
7.10 4.10 Number of PT100 temperature sensors used	44
7.11 Temperature inputs PT1 and PT2	45
7.12 Bypass	47





7.13	Units	48
7.14	TEMP ENABLED.....	48
7.15	CHANGE PASSWORD.....	49
8.	Determining Purging Time.....	50
9.	User Parameter Setting Sheet.....	51
10.	Type Codes	52
11.	Certification	54
11.1	ATEX - UL/DEMKO 14ATEX1282X	54
11.1.1	External	54
11.1.2	Internal	54
11.2	IECEX - UL14.0019X.....	54
11.2.1	External	54
11.2.2	Internal	54
11.3	cULus Class Divisions.....	54
11.4	Applied Standards.....	55
11.4.1	IECEX	55
11.4.2	ATEX	55
11.5	Certification Markings.....	56
11.5.1	Control Unit	56
11.5.2	EPV-5500 Vent Unit.....	57
12.	Troubleshooting	57

1. Preface

We are pleased that you have chosen a quality product from Pepperl+Fuchs.

These operating instructions will help you to meet the safety and protection requirements for systems with explosion protection in equipment group II Zones 2 and 22, Class I or II, Division 2 when installing, commissioning and using the 5500 controller and its components.

This important safety and hazard information will help you to use the 5500 controller safely and correctly.

We reserve the right to make technical changes.

Publisher with responsibility for content:

Pepperl+Fuchs
1600 Enterprise Pkwy
Twinsburg, Ohio 44087

2. Information on these operating instructions

Knowledge of the basic safety regulations and additional training and experience in the area of explosion protection are essential for the safe handling and failure-free operation of this 5500 controller.

These operating instructions contain important data and information to ensure the safe use of the 5500 pressurizing system in hazardous areas and to meet the requirements of Directive 94/9/EC.

These operating instructions, particularly the safety information, must be followed by all personnel who work on the unit.

3. Responsibility of the operator and/or installer

The operator and/or installer undertake to ensure that only specialist, trained personnel work on the 5500 pressurizing system and that they

- are familiar with the occupational safety and accident prevention regulations and have been briefed regarding handling of the unit.
- have the additional knowledge of explosion protection that is required for work on explosion protected components.
- are familiar with the relevant rules and regulations for the installation, operation and maintenance of explosion-protected systems.
- have read the safety section and warnings in these operating instructions.

The operator and/or installer must also ensure that:

- The 2-wire RTDs for temperature sensors are suitable for the area classification, Zone 2 or Zone 22, Class I Zone 2. Maximum length is 3 m.
- The bypass switch is suitable for the area classification, Zone 2 or 22, Class I Zone 2.

4. General information on the ignition protection class - pressurizing system

Pressurizing systems are one of the most versatile ignition protection classes. They are based on the principle that in Zone 2/Class I Division 2 (gas) the gas mixture in the ambient atmosphere, which may ignite under certain circumstances, is removed from the housing by an initial purge process. After the purge phase, sufficient compressed air is supplied to compensate for leaks in the housing and any installed equipment. This permanent overpressure, achieved using compressed air, prevents any potentially explosive atmosphere in the ambient air from entering the housing.

During the purge phase an internal pressure is achieved.

Any hotspots that may occur on individual components within the control cabinet are monitored by temperature sensors (optional) and switched off safely if necessary. This ensures that no unacceptably high surface temperatures can reach the exterior.

For applications in Zone 22/Class II Division 2 (dust) the purge process is omitted because purging would raise explosive dust. Instead of pre-purging, the interior of the housing is inspected for dust and cleaned manually if dust is present.

The purge and pressurizing system is particularly suitable for installed equipment that is not approved for use in hazardous areas. It can then be used directly in the hazardous area.

4.1 Conditions of Safe Use

The main control unit and the EPV vent are the only parts that have been evaluated for the certifications of the system.

For dust environments, the non-metallic membrane touchpad and display may pose an electrostatic discharge hazard. Use only water damp cloth and allow to air dry for cleaning device. Do not use or install in high charge areas. See IEC60079-32-1 for further information.

When mounting the 5500 purge control unit, the unit shall not have the membrane keypad exposed to direct UV light sources and direct sunlight. Example methods of protection include, but are not limited to, indoor applications away from UV sources and outdoor locations under shading. As part of regular inspections, if damage to or deterioration of the membrane keypad is detected the unit is to be taken out of service for repair or replacement.

When the 5500 purge system is mounted to an enclosure, the complete installation shall be evaluated to the appropriate standards and regulations applicable for the final installation location.

The purge control unit has a temperature class (T6 or T4) that is dependent on ambient temperature. This temperature shall be considered when mounted to an enclosure, or inside of an enclosure.

All un-used entry points to the 5500 control unit shall be closed with a properly certified IECEx, ATEX or cULus device suitable for the area of installation with the necessary ingress protection.

The bypass function shall only be enabled during setup or maintenance and only when the area is known to be non-hazardous.

The device shall be installed in an area of not more than pollution degree 2 as defined in IEC/EN 60664-1

The device must be installed in accordance with the manufacturer's installation drawing number 116-B026. '

5. The 5500 Purge and Pressurization System

The 5500 series purge/pressurization system consists of the control unit with a user-interface mounted in a 316 stainless steel enclosure and works in conjunction with the EPV vents and pneumatic solenoid valves or manual valves to comprise the system.

The 5500 is a purge/pressurization controller and is not protected by pressurization.

5.1 5500 Control Unit

The 5500 control unit is a control device in ignition protection for Type Z & Ex pz purge systems and is suitable for purge time and pressure monitoring in Class I or II, Division 2, Zone 2 or 22.

It controls the volume of purge gas flowing into the explosion protected control cabinet and maintains and monitors an overpressure relative to the ambient air when purging is complete.

The 5500 control unit can be ordered for internal or external mount with different optional cable glands/conduit fittings for easy approved wiring methods.



The components of the 5500 series control unit:

- 5500 control unit
- Cable glands/conduit openings available
- Mounting bolts and sealing washers for attaching 5500 control unit to the enclosure
- Hardware for the reference pressure - bulkhead fitting, sealing washer, tubing included
- Installation and instruction manual

5.1.1 Technical Specifications

Supply	
Rated voltage	100 to 240 V AC, 48 ..62 Hz +-10%, single phase 20 to 30 V DC +- 10% Overvoltage category 2
Power consumption	100 to 240 V AC – 2.3VA (without digital valve) 20 to 30 V DC – 2.5 W (without digital valve)
Fuse rating F2	AC: 2.0 A DC: 3.15 A
Terminals	L, N for AC +- for DC
Input - Temperature	
Number of sensors	up to 2 RTDs per unit
Input type	Temperature input
Sensor requirement	PT100, 2-wire connection
Input accuracy	+-2.5% of measurement value + PT100 error
Input - Bypass	
Number of inputs	1
Input type	Mechanical contact
Sensor requirement	Passive contact (switch)
Outputs	
Output I	
Connection	K1, terminals K1/NO, K1/NO
Output type	Enclosure power, (1) SPST
Contact loading	6 A @ 250 V AC, 30V DC resistive load
Inrush current	6 A
Overvoltage	Category 2
Output II	
Connection	K2, terminals K2 (NO, C, NC)
Output type	Alarm, (1) DPST
Contact loading	3 A @ 250 V AC, resistive load, 3 A @ 30 V DC
Inrush current	3 A
Overvoltage	Category 2
Output III	
Connection	Digital valve, terminals SV
Output type	(1) SPST powered contacts from supply power
Fuse F1	0.08 A @ 250 V AC, 0.5 A @ 30 V DC
Inrush current	3 A
Fuse rating	80 mA / AC version, 500 mA / DC version

Membrane Pad	
LED indication	K1: Green – Contact K1 is energized K2: Amber – Contact K2 is energized SV1/encl press.: Blue for safe pressure, Amber for valve on Bypass: Amber when bypass is active PT100 error: Red when fault in PT100 sensor
Pneumatic parameters	
Protective gas supply	Instrument grade air or inert gas
Regulated pressure requirement	29 psig (2 bar)
Safe enclosure pressure for gas	0.3" H ₂ O (0.7 mbar)
Safe enclosure pressure for dust	0.65" H ₂ O (1.6 mbar)
Ambient conditions	
Ambient temperature	-20 °C to +40 °C (-4 F to 104 F) at T6 -20 °C to +60 °C (-4 F to 140 F) at T4
Relative humidity	5 ... 90%, noncondensing
Vibration resistance	5 ... 100 Hz, 1 g, 12 m/s ² , all axes
Impact resistance	30 g, 11 ms, all axes
Maximum altitude	1600 m
Mechanical specifications	
Protection degree	Type 4X, IP 66
Mass	1.4 kg (3.1 lbs)
Dimensions	165 mm x 203 mm x 105 mm (6.5" x 8" x 4.2")
Material	
Housing	316 stainless steel
Pressure ports	316 stainless steel
Membrane pad	Autotex F200XE
Connection Type	Pneumatic
High press port	1/8" NPTF
Low press port	1/8" NPTF
RTD/Bypass Terminals	
5500- bypass and temperature wiring notes	
<ol style="list-style-type: none"> 1.) The minimum wire strand in a stranded wire shall have a diameter of 0.1mm or greater 2.) Wire shall be copper only, rated 80°C minimum 3.) Minimum wire insulation thickness shall be 0.25mm for each conductor 4.) Terminal torque is 0.22Nm to 0.25Nm 5.) The wire strip length is 7mm 6.) There Shall be only one wire per terminal 	
Cable Glands	(3) M12 x 1.5 Wire size: M12 diameter 3-6.5 mm / M20 diameter 10-14 mm
Material	316 stainless steel or nickel plated brass, o-ring EPDM
Conductor cross section min.	0.14 mm ²

Conductor cross section max.	1.5 mm ²
Conductor cross section stranded min.	0.14 mm ²
Conductor cross section stranded max.	1.5 mm ²
Conductor cross section stranded, with ferrule without plastic sleeve min.	0.25 mm ²
Conductor cross section stranded, with ferrule without plastic sleeve max.	1.5 mm ²
Conductor cross section stranded, with ferrule with plastic sleeve min.	0.25 mm ²
Conductor cross section stranded, with ferrule with plastic sleeve max.	0.5 mm ²
Conductor cross section AWG/kcmil min.	28
Conductor cross section AWG/kcmil max.	16
<p>5500 control power connection general wiring notes</p> <p>1.) All applicable local and national wiring codes MUST be followed when wiring the system. Also see IEC60079-14</p> <p>2.) The power supply to this device shall have a separate disconnect. If placed in the hazardous area, it shall be rated for the area it is being installed. Placing the disconnect into the purged enclosure is not a "safe" area since power needs to be applied to the control unit before the purge cycle is complete.</p> <p>3.) PE Ground wire to be same size as largest wire used to bring power into the enclosure. Terminate using ring lug properly crimped at grounding stud in bottom of enclosure.</p> <p>4.) All wire shall be copper only, rated 80°C minimum</p> <p>5.) The minimum wire strand in a stranded wire shall have a diameter of 0.1mm or greater</p> <p>6.) Wire strip length into fixed terminal block is 8mm</p> <p>7.) Terminal torque is 0.5Nm to 0.6Nm</p> <p>8.) There Shall be only one wire per terminal</p> <p>9.) It is recommended to leave a bit of extra wire loop in housing.</p>	
Cable Gland 'P_C'	(3) M20 x 1.5
Material	316 stainless steel or nickel plated brass, o-ring EPDM
Conduit 'PSH'	(3) ½" NPTF
Material	316 stainless steel or nickel plated brass, o-ring EPDM
Conductor cross section min.	0.2 mm ²
Conductor cross section max.	6 mm ²
Conductor cross section stranded min.	0.2 mm ²
Conductor cross section stranded max.	4 mm ²
Conductor cross section stranded, with ferrule without plastic sleeve min.	0.25 mm ²

Conductor cross section stranded, with ferrule without plastic sleeve max.	2.5 mm ²
Conductor cross section stranded, with ferrule with plastic sleeve min.	0.25 mm ²
Conductor cross section stranded, with ferrule with plastic sleeve max.	4 mm ²
Conductor cross section AWG/kcmil min.	24
Conductor cross section AWG/kcmil max.	10

5.1.2 Electrical Connections

External Mount

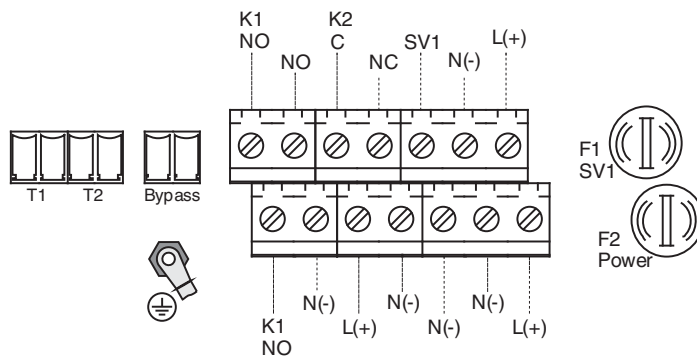

Internal Mount

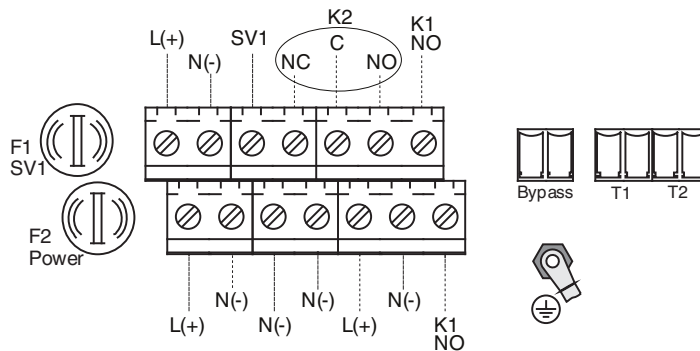

Terminal Block Connections

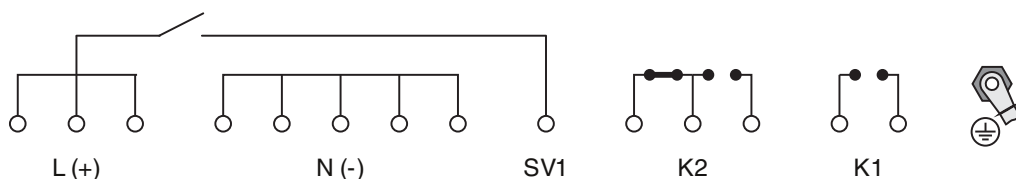

5.1.3 Dimensions

Dimensions - External Mounting

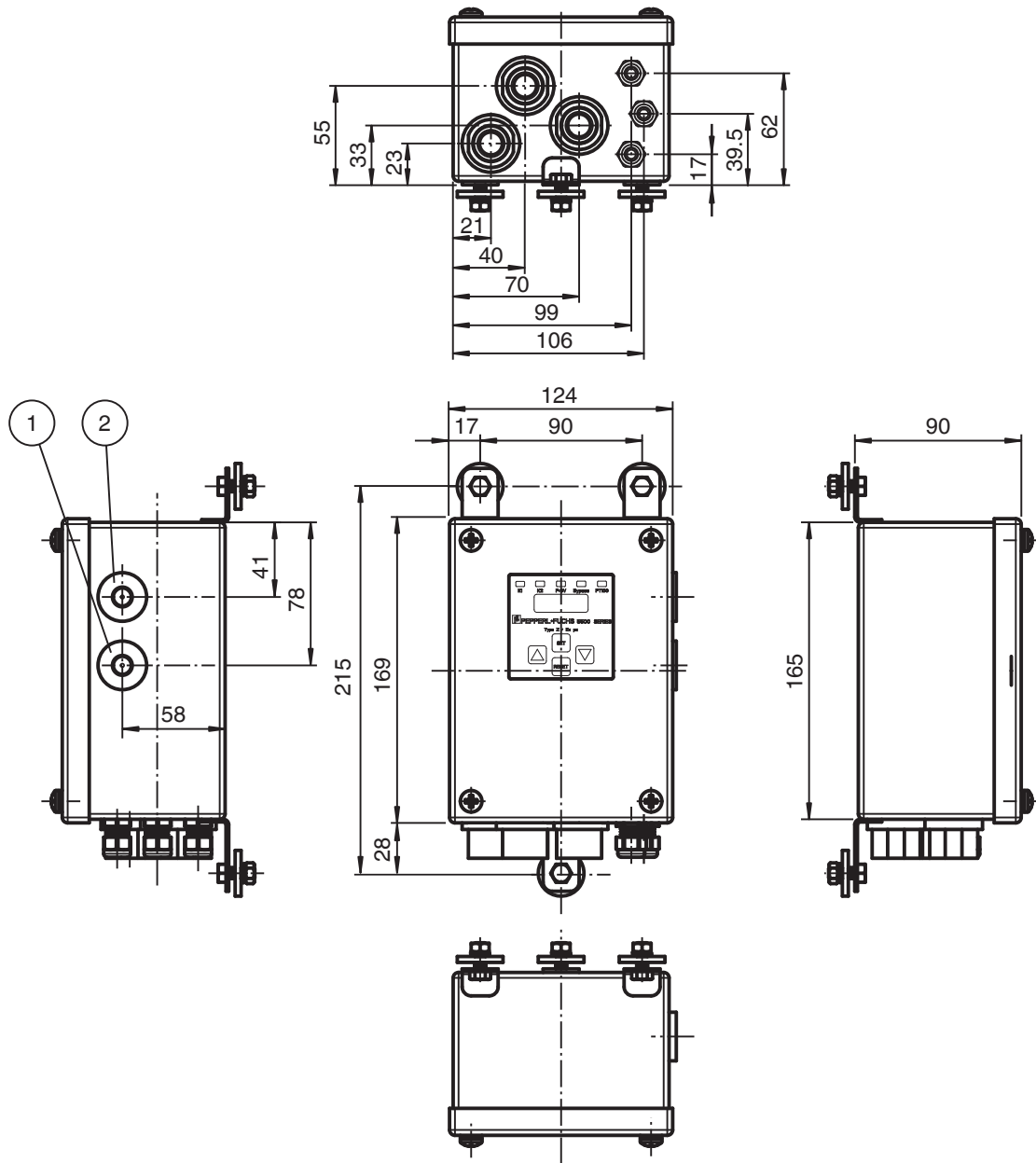

1	Low pressure port (atmospheric pressure)
2	High pressure port (enclosure pressure)

5500 Operating Instructions

For the external mount 5500 control unit, the display can be rotated in 90 degree rotation. No screws are required. To rotate, remove cover and pop out the display. Position display as desired and push back into the pin on the control unit. Do not rotate more than +/- 90 degrees. When rotating display, be careful to not collapse the tubing by bending in extreme angles.

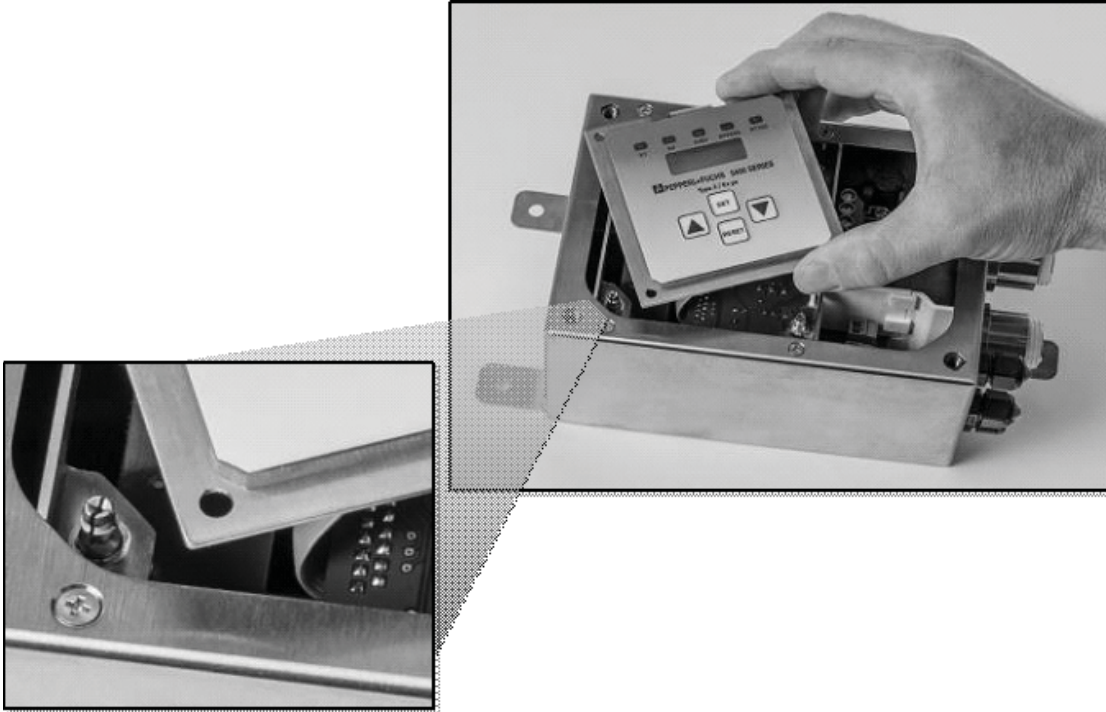

Dimensions - Internal Mounting

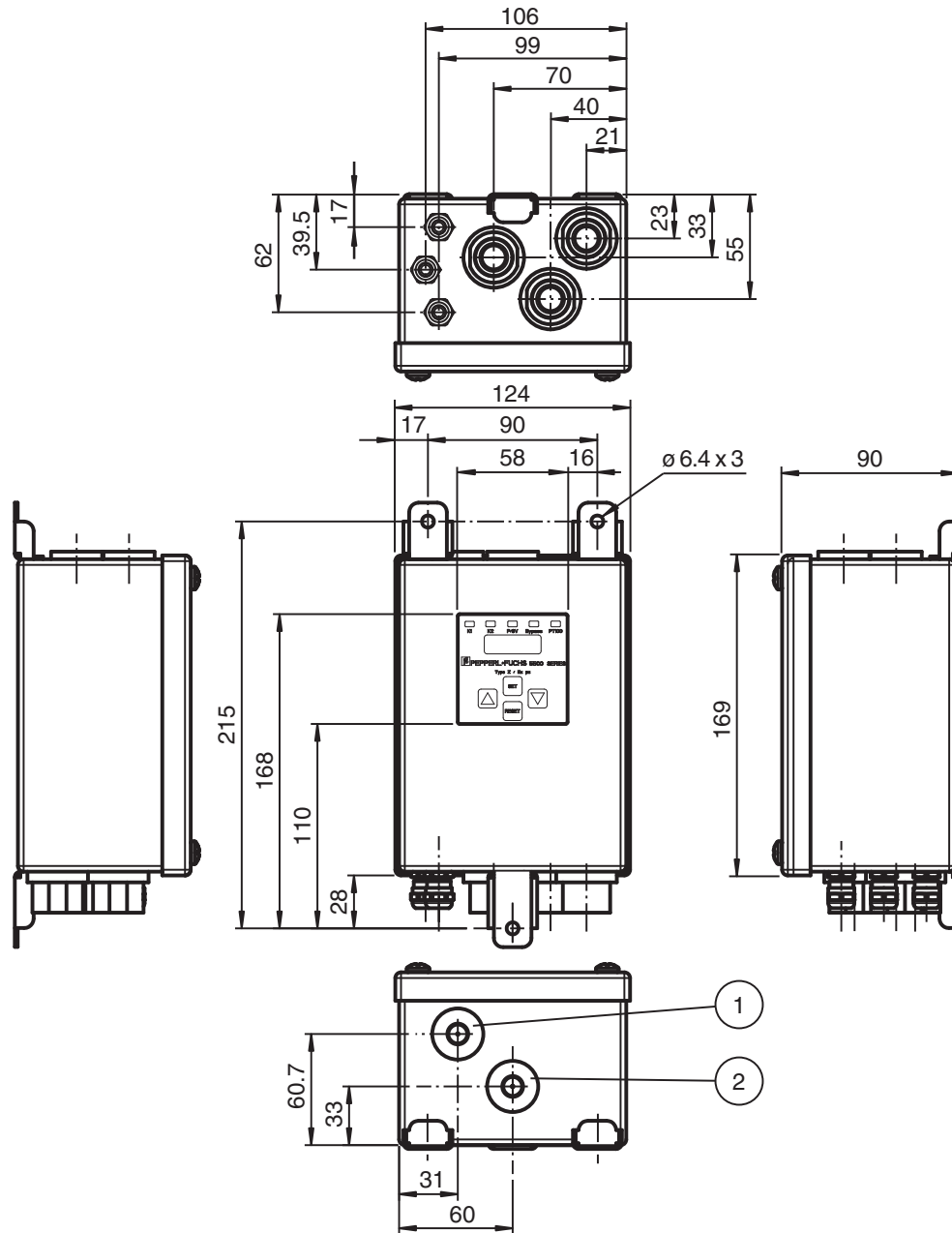

1	Low pressure port (atmospheric pressure)
2	High pressure port (enclosure pressure)

5.1.4 Hardware Kit

The hardware mounting kit is included. It comprises of



mounting hardware



pressure kit: Bulkhead fitting + O-ring, tubing + tubing inserts, straight connector, sintered element for bulkhead fitting

5.1.5 Mounting of the Internal Control Unit

Use the drawing below to mount the external control unit correctly.

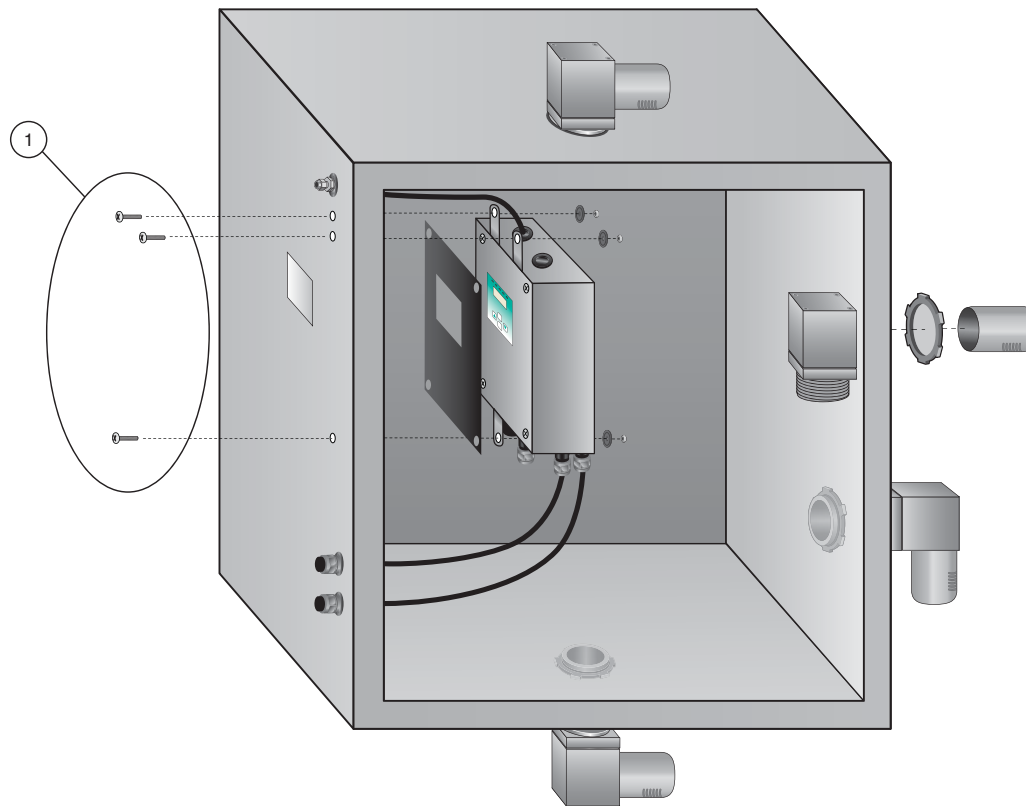

Note

- 1) Internal studs may be added to enclosure for cleaner looking installation.
- 2) Pressure reference kit included. Required to measure ambient pressure outside for the differential pressure sensor within the 5500 control unit. Tubing kit connected to port labeled 'Atmospheric Pressure'.
- 3) Key pad must be mounted in a vertical orientation only.

5.1.6 Mounting of the External Control Unit

Use the drawing below to mount the external control unit correctly.

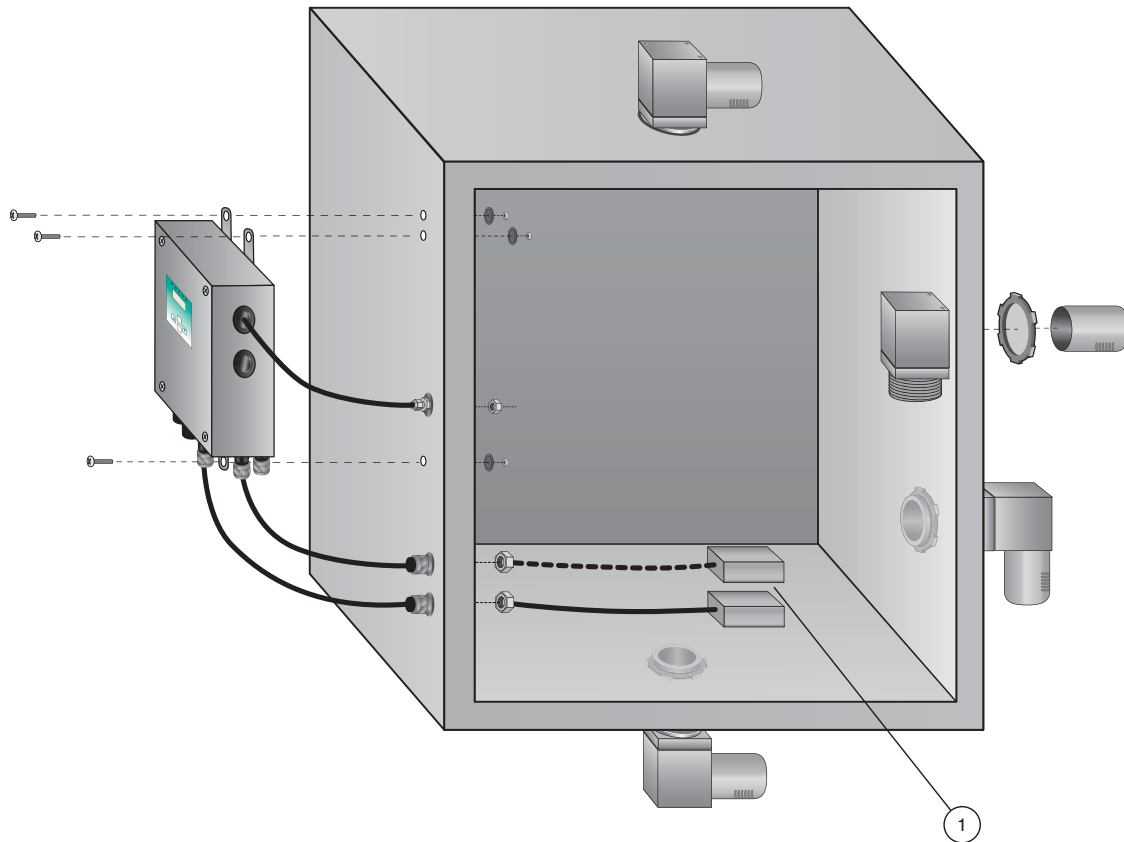

Note

- 1) RTDs - not included.
- 2) Pressure reference kit included. Required to measure ambient pressure outside for the differential pressure sensor within the 5500 control unit. Tubing kit connected to port labeled 'Enclosure Pressure'.
- 3) Key pad must be mounted in a vertical orientation only.

5.2 EPV-5500 Vents

The EPV-5500 vent works with the 5500 control unit and valve to provide a functional, certifiable purge and pressurized system for enclosures. As required by all pressurized enclosure systems, the EPV-5500 vent functions as a pressure relief device and allows the purge gas to exit the enclosure, yet provides a seal when the enclosure is pressurized and operating. The vent also has a spark arrestor which is required for hazardous areas.



The components of the EPV-5500 vent:

- EPV-5500 vent with spark arrestor
- Sealing washer and nut for internal or external mounting
- Hex key for removing/attaching/rotating the vent cap

5.2.1 Technical Specification

Pneumatic parameters	
Protective gas supply	Instrument grade air or inert gas
Maximum pressure	Depends on the integrity of the enclosure (strength)
Purge flow rate	See graphs
Flowrate for leakage compensation	EPV-....-01: approx. 21 scfh (593 l/hr) @ 0.25" wc (0.63 mbar) approx. 58 scfh (1640 l/hr) @ 0.75" wc (1.9 mbar) EPV-....-02: approx. 14 scfh (395 l/hr) @ 0.25" wc (0.63 mbar) approx. 34 scfh (961 l/hr) @ 0.75" wc (1.9 mbar) EPV-....-03: approx. 9.2 scfh (260 l/hr) @ 0.25" wc (0.63 mbar) approx. 22 scfh (622 l/hr) @ 0.75" wc (1.9 mbar)
Breaking pressure	EPV-....-01: 0.8" w.c. (2.0 mbar) EPV-....-02: 1.4" w.c. (3.5 mbar) EPV-....-03: 1.5" w.c. (3.8 mbar)
Ambient conditions	
Ambient temperature	-20 °C to +60 °C (-4 F to 140 F)
Storage temperature	-20 °C to +60 °C (-4 F to 140 F)
Relative humidity	5 ... 90 %, noncondensing
Vibration resistance	5 ... 100 Hz, 1 g, 12 m/s ² , all axes
Impact resistance	30 g, 11 ms, all axes

Mechanical specifications	
Protection degree	EPV-....-01/02: mounting only type 4x EPV-....-03: Type 4X
Mass	EPV-....-01/02/03: approx. 2.2 lb (1005 g)
Dimensions	See dimension drawing
Material	
Housing	EPV-5500-AA...: 6061T6 anodized aluminum (body and cap) EPV-5500-SS...: 6061T6 anodized aluminum (body), 316L stainless steel (cap)
Spark arrestor	316L stainless steel
Installation	Any orientation to enclosure Not gravity dependent Internal and external mounting possible
Mounting	EPV-....-01: mounting hole 1 ½" NPT knockout (50.8 mm) hole sealing nut (provided) EPV-....-02: mounting hole 1 ½" NPT knockout (50.8 mm) hole sealing nut (provided) EPV-....-03: mounting hole 1 ½" NPT knockout (50.8 mm) hole sealing nut (provided)

5.2.2 Flow Rate Curves

The enclosure pressure vs. flow rate curves below represent the EPV-5500....-01, 02, and 03 vents. This corresponds to the enclosure pressure and is independent on the valve used, provided it can deliver the flow rate required.

The curves below represent a completely sealed enclosure which may not be representative of the customer enclosure. More flow may be required to reach the enclosure pressure in the enclosure due to leakages from gaskets, seals, windows, etc.

The EPV-5500-...-01 is usually used on large enclosures because it has a higher flow rate and lower back pressure within the enclosure than the other two versions. This can reduce the time of purging while keeping the enclosure pressure low which is important for a large enclosure. However, this vent will leak more pressure through its flow control mechanism.

The EPV-5500-...-02 provides a better seal at the vent than the EPV-5500-...-01. The flow rate for purging will be less for the same enclosure pressure of the '-01' version.

The EPV-5500-...03 gives the best seal for pressurization and should be selected for a smaller enclosure, bottled air, or inert gas sources, and for increase conserving of protective gas source. The flow rate will be less than the '-01' and '-02' versions but provides very low leakage.

There is no restriction of enclosure size for each vent, but leakage rate, flow rate, and enclosure pressure should be considered when applying these vents and the purge time 166 min.



5500 Operating Instructions

If you are using the EPV-5500...-01 you will use one of the following three curves to determine your flow rate. The size of your enclosure will determine which curve to use. The first curve is for an enclosure up to 5 cubic feet, the second curve is for an enclosure between 5-15 cubic feet and the third curve is for an enclosure 15 cubic feet and larger. Once you determine which curve matches your application, you can determine your flow rate from the pressure reading.

Vent Flow vs. Pressure (EPV-5500-...-01)
Enclosure up to 5 Cubic Feet

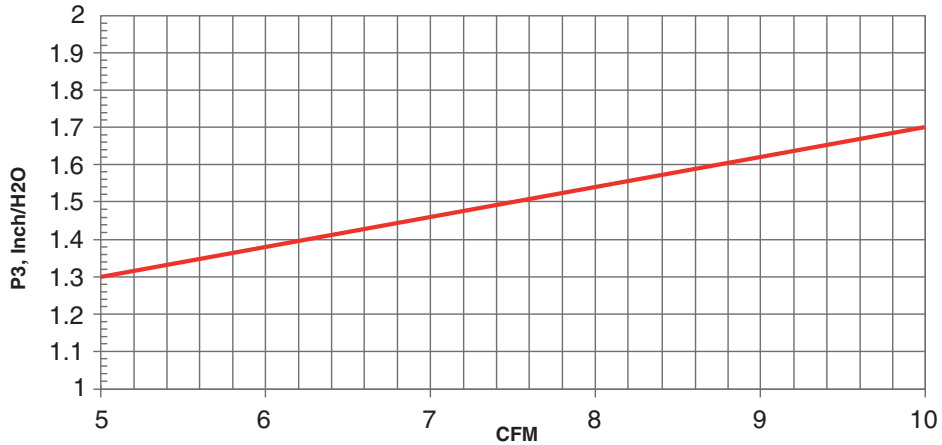

Vent Flow vs. Pressure (EPV-5500-...-01)
Enclosure up to 5-15 Cubic Feet

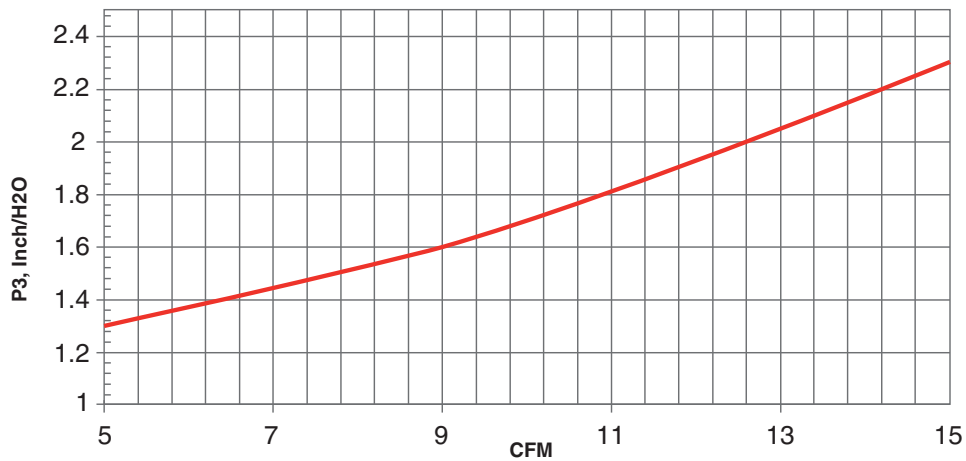



Vent Flow vs. Pressure (EPV-5500-...-01)
Enclosure 15 Cubic Feet and up

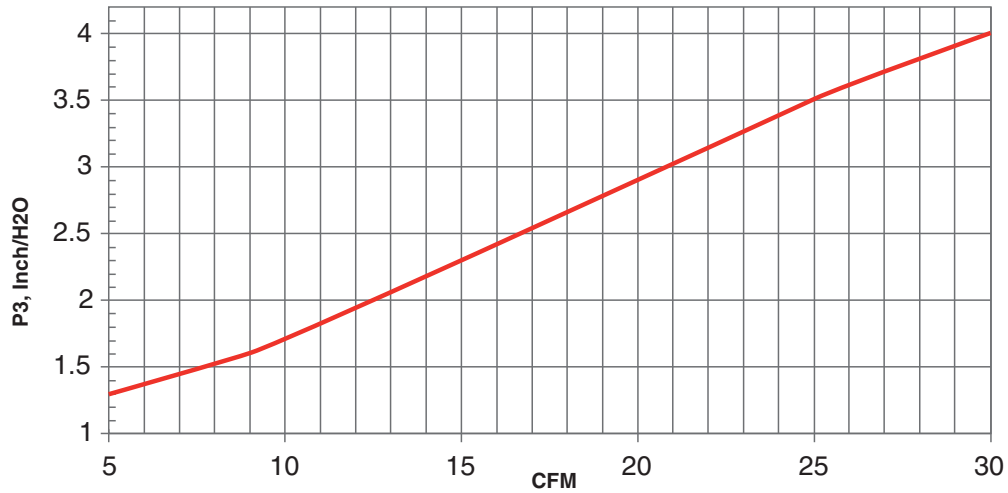

If you are using the EPV-5500...-02 you will use one of the following three curves to determine your flow rate. The size of your enclosure will determine what curve to use. The first curve is for an enclosure up to 5 cubic feet, the second curve is for an enclosure between 5-15 cubic feet and the third curve is for an enclosure 15 cubic feet and larger. Once you determine which curve matches your application you can determine your flow rate from the pressure reading.

Vent Flow vs. Pressure (EPV-5500-...-02)
Enclosure up to 5 Cubic Feet

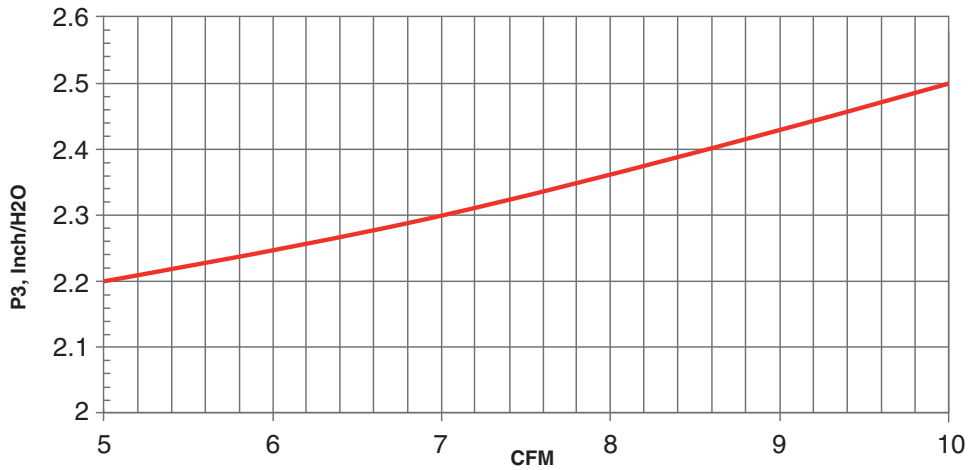



Vent Flow vs. Pressure (EPV-5500-...-02)
Enclosure 5-15 Cubic Feet

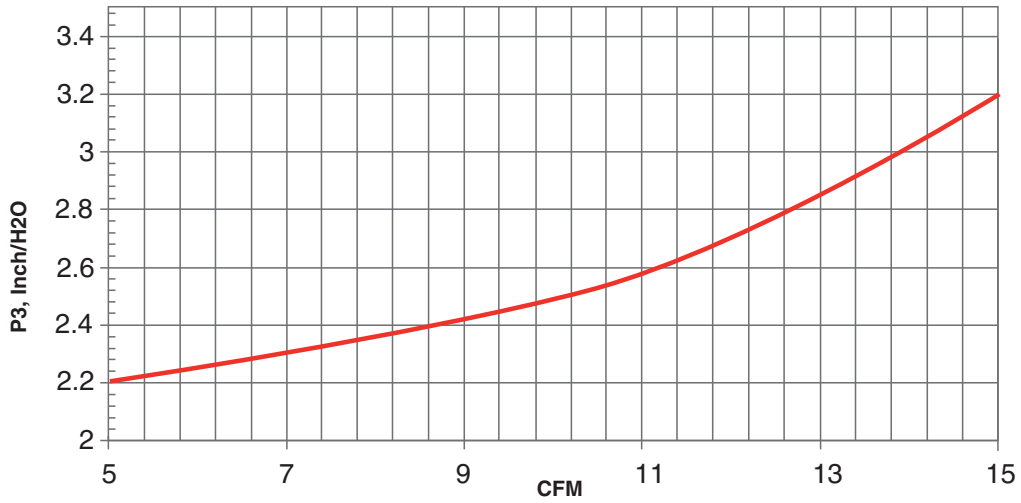

Vent Flow vs. Pressure (EPV-5500-...-02)
Enclosure 15 Cubic Feet and up

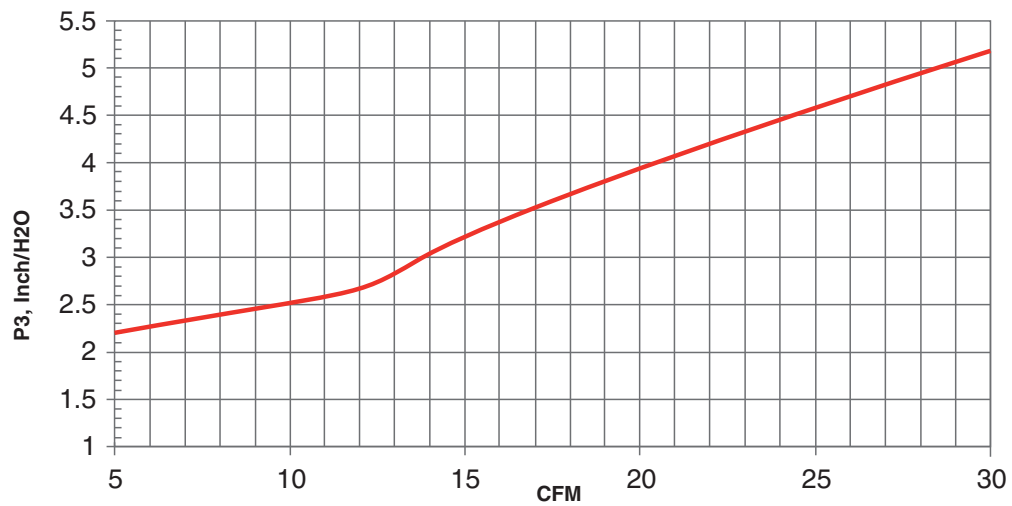

If you are using the EPV-5500...-03 then you will use the curve shown below.

Vent Flow vs. Pressure (EPV-5500...-03)

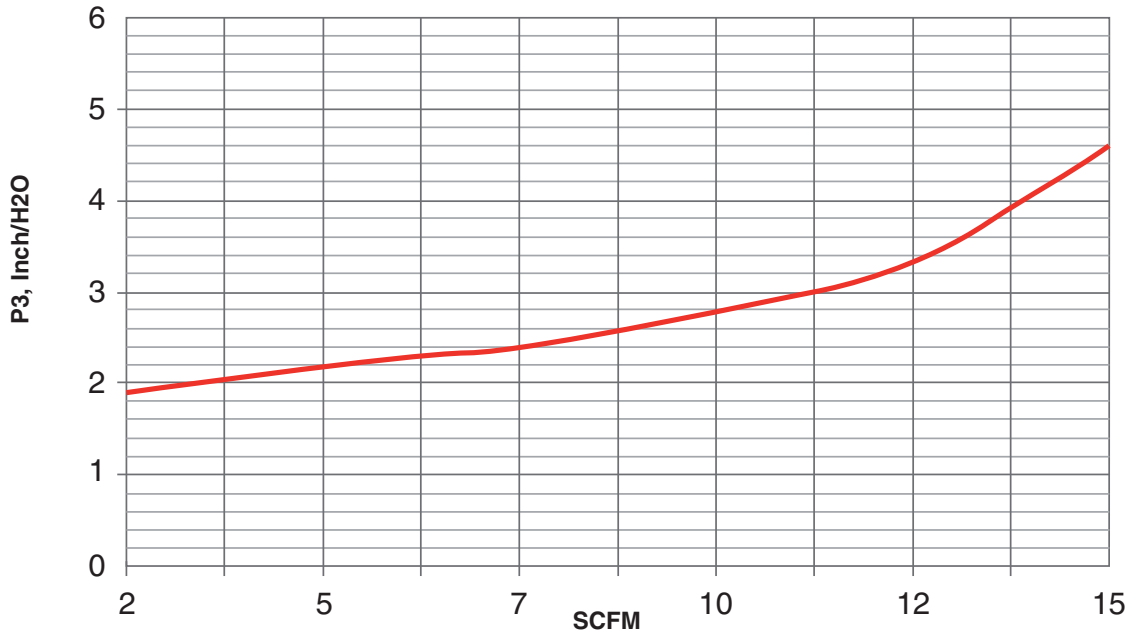

5.2.3 Dimensions

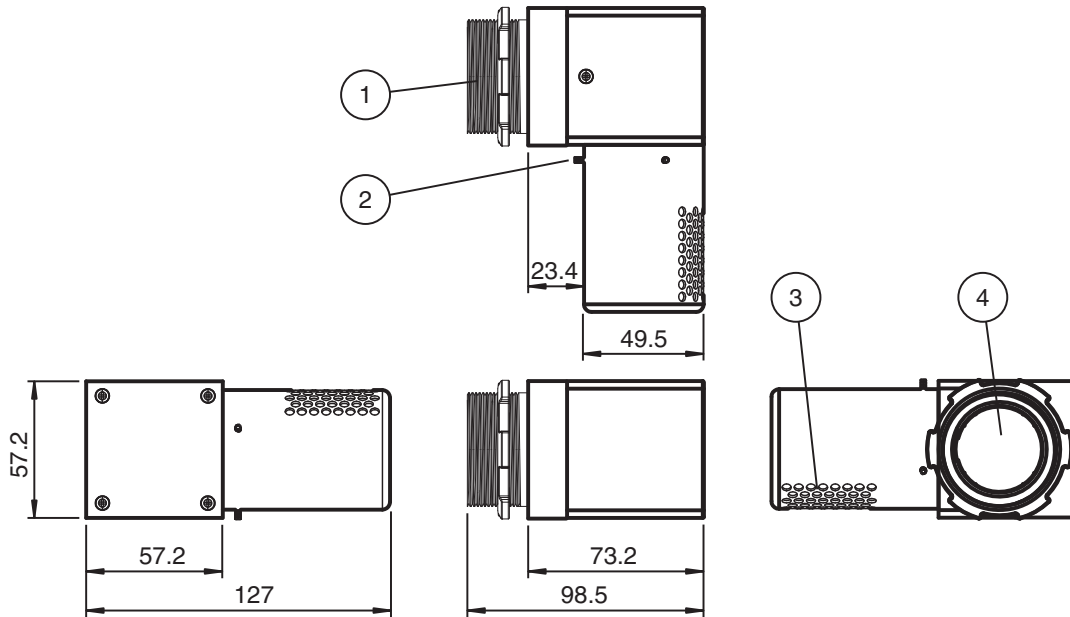

1	1 ½ NPS thread
2	(3) hex key 0.050" (included)
3	Exhaust port
4	Inlet port

5.3 Manifold Valves

The 5500-MAN.... manifold valve includes a solenoid valve for purging and a needle valve for pressurization in one manifold design.

When the valve is energized, the solenoid valve is open and allows for a high flow rate of protective gas into the enclosure. The amount of flow is controlled by the regulated pressure supply of the protective gas to the manifold. When the valve is de-energized, the flow is through the internal needle valve and is adjustable by using the included hex key (for CDUL valve) or slotted screw driver (EX01 and CD01 valve). The solenoid valve is used for purging, leakage compensation, and temperature control with signals from the 5500 control unit that will have these set points set up by the user.

Mounting hardware includes 3/8" tube compression fittings mounted on the manifold for input and output flow, 3/8" tube compression bulkhead fitting for getting flow into the enclosure and UL certified sealing washers with bolts to mount the manifold to the enclosure.

Also included is 1 meter of 3/8" poly tubing with 3/8" poly tube stiffener inserts which allows users to connect plastic tubing to compression fittings without collapsing the tubing. Stainless steel tubing can be used with existing fittings.

For NEC, ATEX and IECEx applications, look at the model number key for the correct model.

The 5500 valve system works with the 5500 control unit and EPV-5500 vents.

The 5500 system has UL certification for Class/Division installation.

The manifolds are optional and the user can use their own pneumatic system. These valves are not part of the evaluation of the certification of the 5500 Control unit and EPV-5500.. vent. They have their own certification.

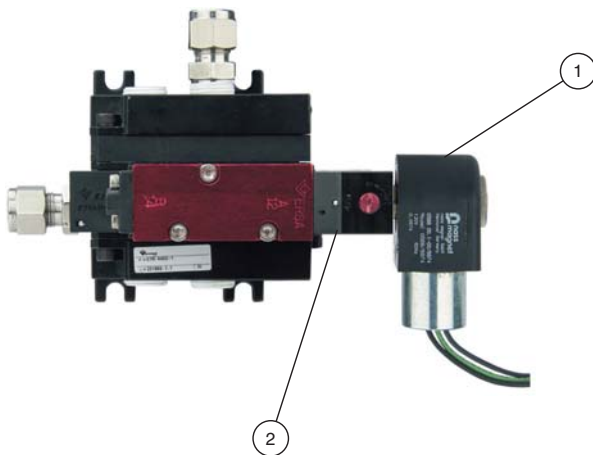

1	Solenoid coil for purging
2	1/8" hex key adjustment for pressurization (hex key included)



Tubing kit included



Mounting hardware included

Manifold includes solenoid and manual needle valve

- 3/8" compression ferrule fittings for inlet and outlet protective gas source
- 3/8" compression ferrule bulkhead fitting that attaches to enclosure – for protective gas to inside enclosure
- 3/8" poly tubing, L=2meters
- Inserts for poly tubing to ferrule fitting connection. If stainless steel tubing is used, inserts are not required.
- Hex key for pressurization valve included with 5500-MAN-CDUL version



Note

When ordering, please note the supply voltage of the 5500 control unit. Please order manifold valves accordingly. Voltages are 24 V DC, 120 V AC, 220 V AC. 5500 MAN-CDUL manifold valves are only available with 60 Hz operation.

5.3.1 Technical Specifications

General Specifications	
Operation mode	For automatic purging
Series	5500
Hazardous environment	Gas or dust
Supply	
Rated power requirement	5500-MAN-CDUL
24 V DC	5.6 W
120 V AC	7.2 VA, 60 Hz
230 V AC	7.2 VA, 60 Hz
Rated power requirement	5500-MAN-CD01
24 V DC	4.6 W
120 V AC	6.8 VA, 60 Hz
230 V AC	6.8 VA, 60 Hz
Rated power requirement	5500-MAN-EX01

5500 Operating Instructions

24 V DC	2.6 W
120 V AC	3.1 VA, 50 ... 60 Hz
230 V AC	3.0 VA, 50 ... 60 Hz
Voltage tolerance	±10 %
Fuse rating on 5500 control unit	
DC voltage	500 mA
AC voltage	80 mA
Pneumatic Parameters	5500-MAN-CDUL (only 60Hz for AC version)
Protective gas supply	Instrument grade air or inert gas
Pressure requirement	20 psi (1.4 bar) to 120 psi (8.2 bar)
Purge flow rate (solenoid valve)	Cv (flow coefficient) = 1.4
Pressurization flow (needle valve)	Cv (flow coefficient) = 0.24
Pneumatic Parameters	5500-MAN-CD01
Protective gas supply	Instrument grade air or inert gas
Pressure requirement	20 psi (1.4 bar) to 120 psi (8.2 bar)
Purge flow rate (solenoid valve)	Cv (flow coefficient) = 1.4
Pressurization flow (needle valve)	Cv (flow coefficient) = 0.24
Pneumatic Parameters	5500-MAN-EX01
Protective gas supply	Instrument grade air or inert gas
Pressure requirement	25 psi (1.7 bar) to 115 psi (8.0 bar)
Purge flow rate (solenoid valve)	Cv (flow coefficient) = 1.4
Pressurization flow (needle valve)	Cv (flow coefficient) = 0.24
Mechanical Specification	
Protection degree (connector)	Type 7&9
Mass	2.8 lbs (1250 grams)
Dimensions	see dimension drawing
Material	
Housing	Anodized aluminum
3/8" compression fittings	316 stainless steel
Pressure ports	3/8" NPTF
Bulkhead fitting	316 stainless steel
Mounting bolts	¼-20, 316 stainless steel
Sealing washers	
Pneumatic connection type	Pneumatic
Input port	3/8" tube compression fitting
Output port	3/8" tube compression fitting
Electrical connection	
5500-MAN-CD	½" NPTF thread connection w/ 24" (0.61 m) flying leads
5500-MAN-EX01	3 meter cable



During installation, ensure that no foreign bodies lie inside or can enter the valve.
The digital valve must be 'EX' rated for mounting in a hazardous area.

5.3.2 Dimensions

5500-MAN-CDUL

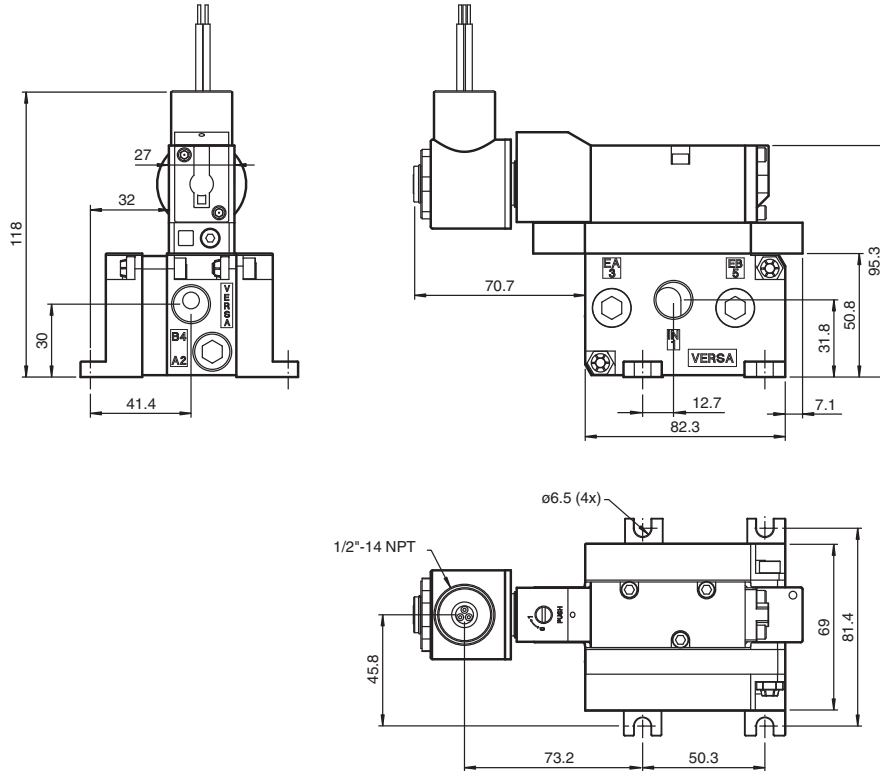

5500-MAN-EX01

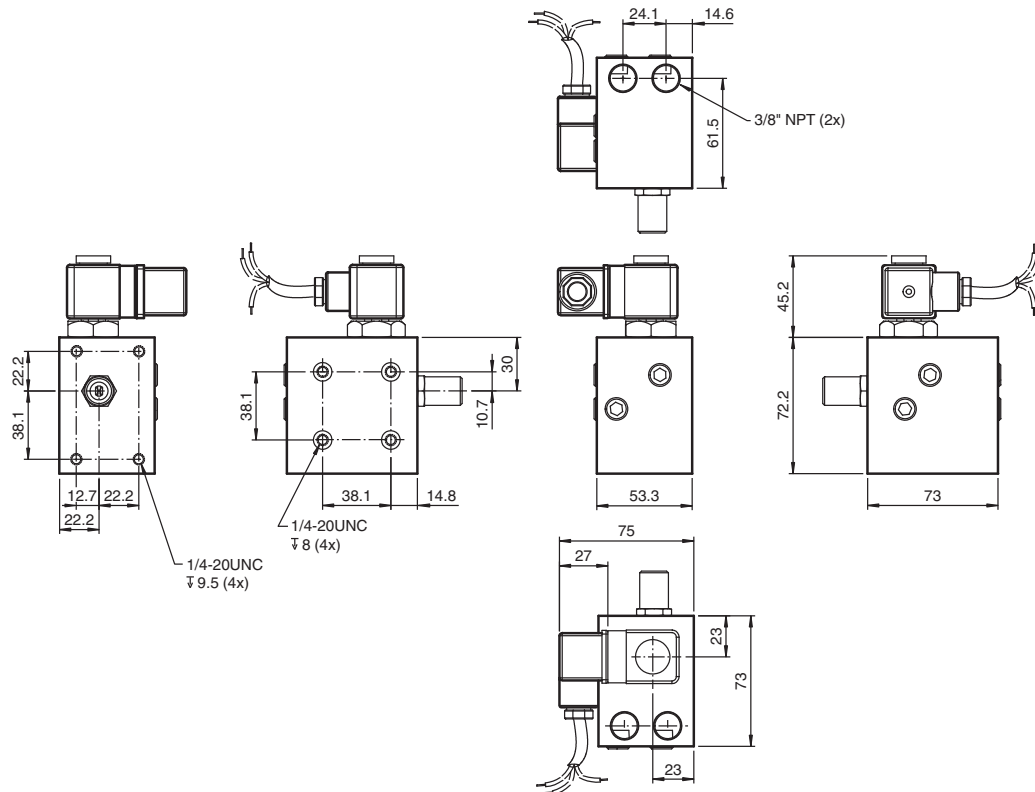

5500-MAN-CD01

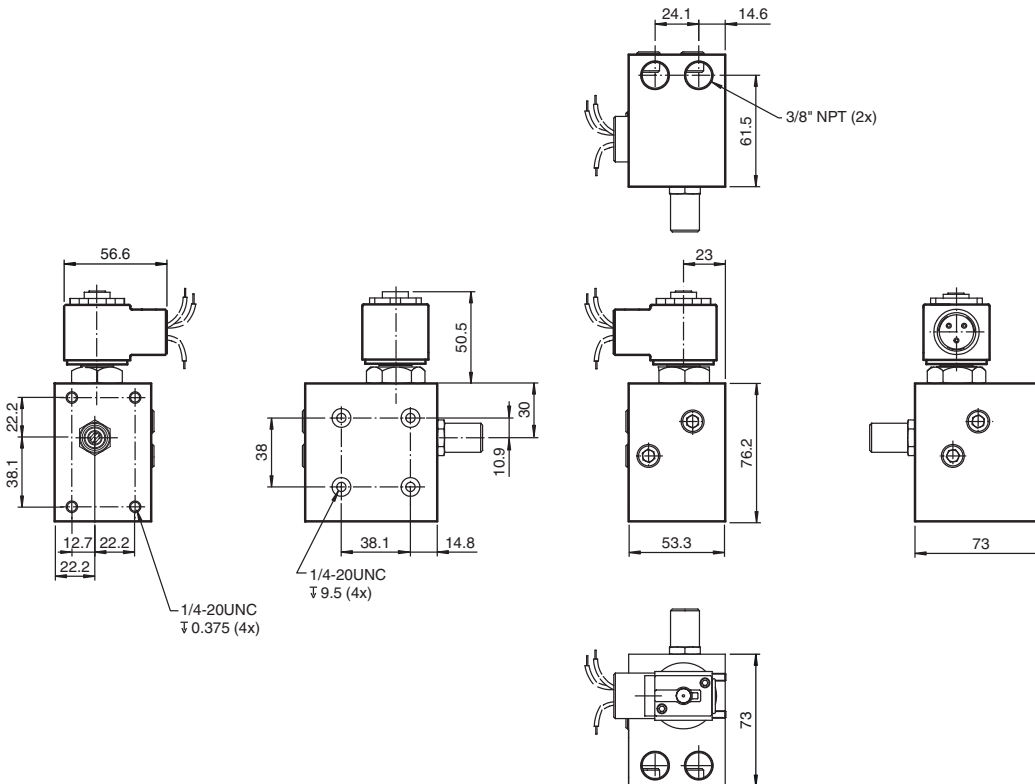

6. Installation and Operation of the 5500 System

The 5500 series control unit, vent, and manifold, can be universally mounted to the customer enclosure. The control unit can be mounted within the enclosure or outside the enclosure and can be to the left, right, top or bottom of the enclosure because the display can be rotated for those positions. The EPV-5500 vent can be externally or internally mounted with just the cap showing for exhaust of pressure.

The 5500 system is designed to allow the enclosure to be located in Zone 2 or 22, Class I or II, Division 2 hazardous locations to operate safely by first making them safe internally either by purging out the hazardous gas or manually cleaning out the dust hazard and then pressurizing the enclosure so that the internal pressure prevents the hazardous atmosphere from getting in. The 5500 control unit has a differential pressure sensor within the unit that is pneumatically connected to the protective enclosure and will provide pressure for evaluation of the enclosure pressure and the flow through the enclosure during purging. If pressure is lost then power can remain on. Take care that an indication by an alarm or display has to notify operator of condition. If pressurized enclosure has been opened or positive pressure has not been maintained, then purging for hazardous gas or cleaning the enclosure out for dust atmospheres is required. The flow measurement is evaluated by using the pressure in the enclosure and the known measured flow in the graphs through one of the vents selected.

6.1 For Gas Atmospheres

If the protective enclosure has been opened or has been subjected to the hazardous atmosphere, purging is required to flush out the hazardous gas that may be inside the protective enclosure. A protective gas is introduced into the enclosure so that the pressure builds up and is exhausted through the enclosure. The measurement of flow is achieved by the 5500 control unit pressure sensor measuring enclosure pressure and using that pressure for the flow graphs of the vent selected and enclosure size. Each vent has an enclosure pressure vs flow curve for enclosure size that can be used to determine flow rate. This flow rate is used to determine the purging time required to make the protective enclosure safe.

NOTE: The flow rate curves generated for each vent are measured on a completely sealed enclosure with no leakage from the enclosure. In real applications, there will be some leakage from the enclosure which will depend on the intergirty of the seals, door windows, etc. As the enclosure pressure increases, the leakage may increase. Always plan on more flow from the protective gas to achieve enclosure pressure because of the leakage.

After purging, then the flow into the enclosure can be reduced so that just a small flow is used for leakage compensation for pressurization of the enclosure.

6.2 For Dust Atmospheres

If the protective enclosure has been opened or has been subjected to the hazardous atmosphere, then the enclosure must be manually cleaned of all combustible dust, closed up, and pressurized before energizing power to the enclosure. For dust atmospheres a higher pressure is required for pressurization and is reflected in the pressure range within the 5500 programming setup.

Setting up the 5500 series system

1. Ensure that the system meets all electrical, mechanical, and pneumatic connections before operation. Please refer to this manual and standards for explanation of requirements.
2. Apply power to the 5500 series system.
3. Program the 5500 system using the User-interface on the front of the 5500 control

unit. Please see 'User-Interface Menu' for instructions.

NOTE: This step is for initial set-up of the 55000 system. This procedure can be skipped if the 5500 control unit has been programmed for the application where it will be used.

4. Make sure the control valve is closed before applying pressure to the system.
5. Use a regulated pressure source to the valve. Set the regulated pressure to 30 psig (2 bar) or lower. Do not exceed the maximum pressure for the valve and tubing being used.
6. Select the user-interface display so that the enclosure pressure is showing. The pressure should be below 0.1" wc (0.25 mbar). Slowly open the needle valve on the control valve system so that the pressure is above P1. If one of the 5500-MAN... is being used, the solenoid valve will energize for purging above P1.
7. Check the EPV vent to make sure air is coming out of it. If not, check for any obstructions or improper installation
8. System is ready to operate.

Operating the 5500 Series System

1. Follow 'Set-up procedures of the 5500 series system' listed in this manual.
2. For Flush Program 1 through 4 (hazardous gas environments), purging is required.
 - a. Seal the pressurized enclosure.
 - b. Set enclosure pressure to a value above P1.
 - c. When using the 5500-MAN... the manifold valve is connected to SV1 output, when enclosure pressure is greater than P1, SV1 energized the solenoid valve for purging. For manual or other valves, initiate the purging valve.
 - d. Adjust the regulated pressure so that enclosure pressure is above P3 (Purging starts).
 - e. For the 5500-MAN manifold, after purging, the needle valve can be re-adjusted to users desire, but must be above P1 value.
3. For Flush Program 5 (hazardous dust environment), purging is not required.
 - a. The inside of the enclosure must be cleaned of all combustible dust.
 - b. The enclosure is sealed.
 - c. Adjust the enclosure pressure above P1. The minimum for P1 is 1.0" wc (2.5 mbar) for hazardous dust environments.
4. If enclosure pressure is above P1, power to the enclosure will be energized.
5. If enclosure pressure drops below P1, then power must be disconnected. If power is to remain on, then an alarm must be initiated and located near an operator.
6. To energize the pressurized enclosure again, repeat above sequence.



All 5500 pressurization systems require EPV-5500... vents for pressure relief.

7. Programming the 5500 control unit

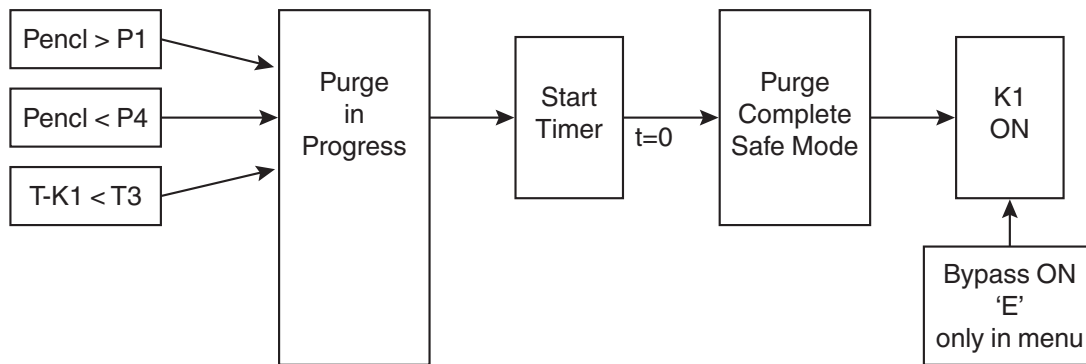

To program the 5500 control unit, use the membrane pad on the front of the unit.

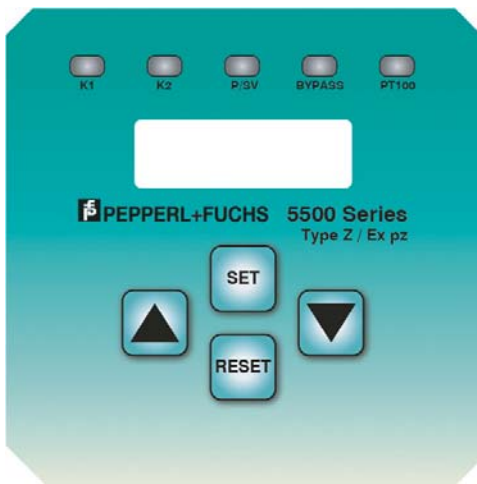





Program settings are saved on non-volatile memory within the CPU, and settings are unaffected by power down and reset function.

Default values are stored and can be restored.

7.1 LED Indication

	LED Color	Description
K1	Green	Contact K1 is energized
K2	Amber	Contact K2 is energized
P/SV	Blue/amber	Blue: safe pressure Amber: valve on
BYPASS	Amber	Bypass is ON
PT100	Red	PT100 is in fault mode

7.1.1 Buttons

Button	Description
	To advance up
	To advance down
	The set button has three functions: 1. Hold for 5 seconds to enter the purge settings 2. Press to advance into the purge setting parameters you have selected 3. Press to enter the purge setting you have selected
	: The reset button has two functions: 1. When in the purge settings mode, the RESET exits out of the parameter menu 2. When in operation mode, when pressed for 5 seconds, will act like a power interrupt. Any settings programmed will not be lost. The action of the reset happens when the reset button is pressed a second time after the menu shows 'RESET ?' This is NOT a restore to default settings.

The following table shows all the possible parameters and their default values:

Display	Description	Default values
PASSWORD / SET	Enter password to access Purge Settings	0000
PURGE / PROGRAM	Up to 5 programs to select	3
PURGE / TIME	Time required for purging	00:30
ENCLOSUR / PRESS P1	Enclosure pressure P1	0.3" (gas), 0.7" (dust) 0.75 mbar (gas), 1.75 mbar (dust)
ENCLOSUR / PRESS P2	Enclosure pressure P2	0.8" (2 mbar)
ENCLOSUR / PRESS P3	Enclosure pressure P3	3.0" (7.5 mbar)
ENCLOSUR / PRESS P4	Enclosure pressure P4	6.0" (15 mbar)
LEAKAGE / HYST	Compensates for excess leakages	0.5" H ₂ O (1.25 mbar)
PROGRAM / K2	Various parameters to activate K2 contacts	K1
SHUT-OFF / DELAY	Delay in turning K1 off when P<P1	0 sec
NUMBER / OF PT100	Number of PT100s being used	0
TEMP PT1 / SV1	SV1 turns on above PT1	35 °C
TEMP PT2 / SV1	SV1 turns on above PT2	35 °C

Display	Description	Default values
TEMP PT1 / K2	K2 turns on above PT1	45 °C
TEMP PT2 / K2	K2 turns on above PT2	45 °C
TEMP PT1 / K1	K1 turns on above PT1	50 °C
TEMP PT2 / K1	K1 turns on above PT2	50 °C
BYPASS / N Y E	N for no, Y for yes, E for external bypass	N
UNITS / M I	M for metric units, I for imperial units	I
TEMP / ENABLED	Temperature monitoring on or off	N
CHANGE / PASSWORD	Change existing password	

Restoring Default Settings

To restore default settings, proceed as follows:

- Hold the UP and DOWN buttons at the same time while power up the control unit. Once power to the control unit is on, the default settings will be restored.

NOTE: If temperature sensor(s) are connected to the unit, then an error will occur for the PT100 because the function is disabled as a default.

Adjusting the Contrast

To adjust the contrast, proceed as follows:

- Hold the UP and DOWN buttons for 3 seconds at the same time. The menu will show the contrast level.
- Adjust the contrast by using the UP and DOWN buttons: use UP button to increase the contrast. Use DOWN button to decrease the contrast.

LCD Backlight

LCD backlight is always on. It cannot be turned off or adjusted.

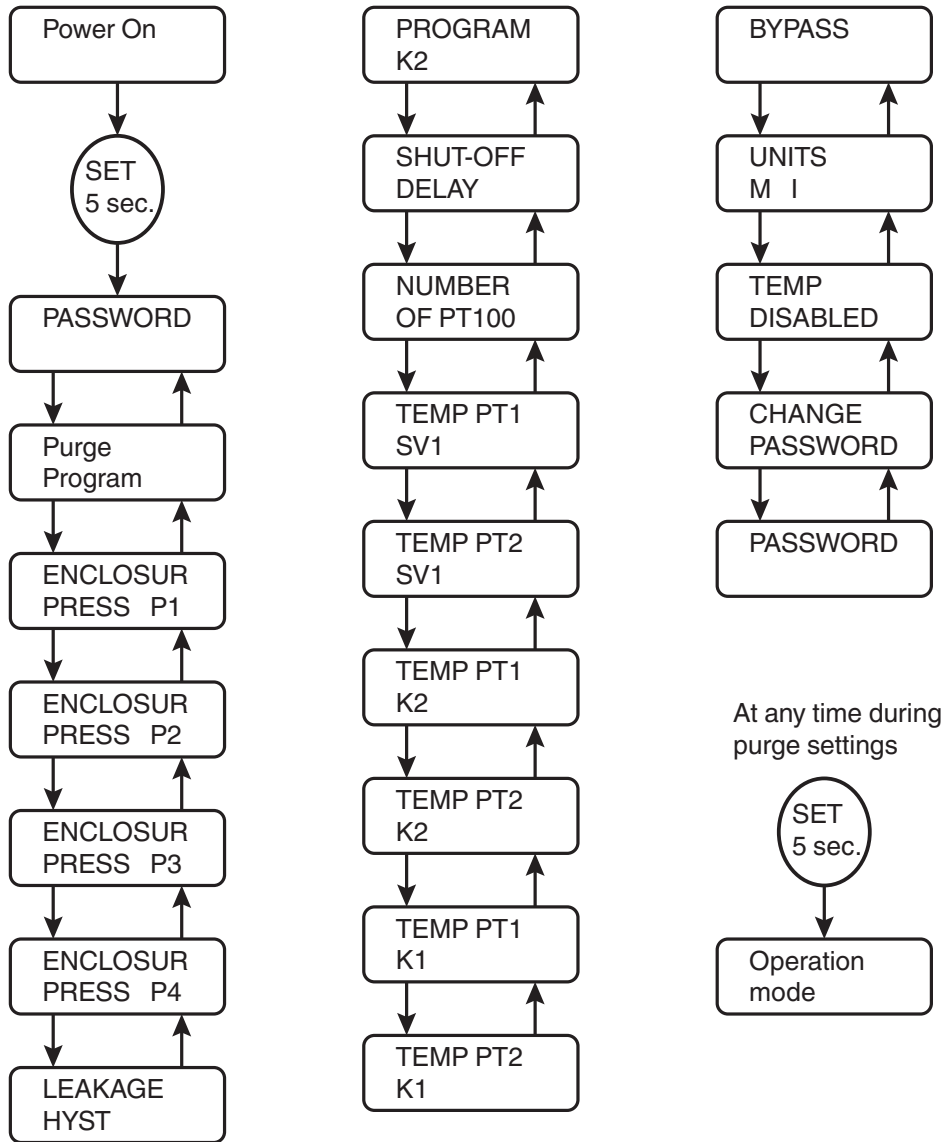

7.2 The Purge Programming Settings

There are 5 program selections for the operation of the system. Programs 1 thru 4 are for hazardous gas environments and require purging. The 5th program is for hazardous dust environments that require cleaning the enclosure then pressurizing.

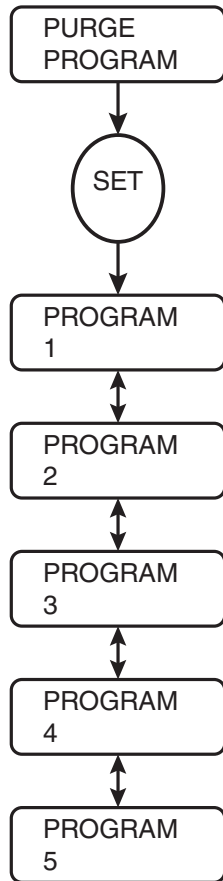

7.2.1 Program 1

Program 1 is used in hazardous gas atmospheres.

Pre-Purge

- The purge valve (SV) is immediately energized regardless of enclosure pressure
- If enclosure pressure goes above P4 during purging, SV will shut off but will energize when below P4. Oscillation of SV may be noticed.
- Setting the pressurization valve on the manifold will have to be done after purging or the power to SV will have to be interrupted to set this pressure. The solenoid valve on the manifold is immediately energized before this pressure can be set.
- Purge timer begins counting down when enclosure pressure is greater than P3 and must remain greater than P3 to finish a successful purging. If the pressure drops below P3 at anytime, or for any length of time, the purge timer is reset and will not begin counting down until pressure is greater than P3.

Operation mode

- After the purge timer counts down, the SV will shut off and K1 is energized.
- If enclosure pressure drops below P2, the SV is energized and will stay energized for the value of HYST (% , leakage compensation). If HYST is set to 0, then leakage compensation is turned off.
- If enclosure pressure drops below P1, K1 remains on and an alarm shall be implemented. K2 can be set to P- or Alarm to indicate below safe or operating pressure.
- If enclosure pressure goes above P4, K1 remains. If K2 is setup as Alarm, then K2 will energize.

Note: If K1 is used to energize power to the enclosure, then if during operation of the system if enclosure pressure is below P1, K1 will remain energized. An alarm is required and must be located so an operator will be notified of the alarm.

7.2.2 Program 2

Program 2 is used in hazardous gas atmospheres.

Pre-Purge

- The purge valve (SV) is energized when enclosure pressure is greater than P1.
- If enclosure pressure goes above P4 during purging, the SV will shut off but will energize when below P4. Oscillation of SV may be noticed.
- Setting the pressurization valve on the manifold will have to be done after purging or the power to SV will have to be interrupted to set this pressure. The solenoid valve is energized once enclosure pressure is above P1. Adjusting the pressurization valve before the solenoid valve is energized will allow the enclosure pressure to be above P1 when purging is completed. Fine adjustment of P1 can be achieved after purging when solenoid valve is off.
- Purge timer begins counting down when enclosure pressure is greater than P3 and must remain greater than P3 to finish a successful purging. If the pressure drops below P3 at anytime, or for any length of time during purging, the purge timer is reset and will not begin counting down until pressure is greater than P3.

Operation Mode

- After the purge timer counts down, the SV will shut off and K1 is energized.
- If enclosure pressure drops below P2, the SV is energized and will stay energized for the value of HYST (% , leakage compensation). If HYST is set to 0, then leakage compensation is turned off.
- If enclosure pressure drops below P1, K1 remains on and an alarm shall be implemented. K2 can be set to P- or Alarm to indicate below safe or operating pressure.
- If enclosure pressure goes above P4, K1 remains. If K2 is setup as Alarm, then K2 will energize.

NOTE: If enclosure pressure is below P1 when K1 is used to provide power to the enclosure during operation, K1 will remain energized. An alarm is required and must be located so an operator will be notified of the alarm.

7.2.3 Program 3

Program 3 is used in hazardous gas atmospheres.

Pre-Purge

- The purge valve (SV) is energized when enclosure pressure is greater than P1.
- If enclosure pressure goes above P4 during purging, the SV will shut off but will energize when below P4. Oscillation of SV may be noticed.
- Setting the pressurization valve on the manifold will have to be done after purging or the power to SV will have to be interrupted to set this pressure. The solenoid valve on the is energized once enclosure pressure is above P1. Adjusting the pressurization valve before the solenoid valve is energized will allow the enclosure pressure to be above P1 when purging is completed. Fine adjustment of P1 can be achieved after purging when solenoid valve is off.

Operation Mode

- After the purge timer counts down, the SV will shut off and K1 is energized.
- If enclosure pressure drops below P2, the SV is energized and will stay energized for the value of HYST (% , leakage compensation). If HYST is set to 0, then leakage compensation is turned off.
- If enclosure pressure drops below P1, K1 turns off immediately or after Shutdown delay timer times out. K1 remains off until enclosure goes through a successful purging
- If enclosure pressure goes above P4, K1 remains. If K2 is setup as Alarm, then K2 will energize.

7.2.4 Program 4

Program 4 is used in hazardous gas atmospheres.

Pre-Purge

- The purge valve (SV) is immediately energized regardless of enclosure pressure.
- If enclosure pressure goes above P4 during purging, the SV will shut off but will energize when below P4. Oscillation of SV may be noticed.
- Setting the pressurization valve on the manifold will have to be done after purging or the power to SV will have to be interrupted to set this pressure. The solenoid valve on the manifold is immediately energized before this pressure can be set.
- Purge timer begins counting down when enclosure pressure is greater than P3 and has to remain greater than P3 to finish a successful purging. If the pressure drops below P3 at anytime, or for any length of time during purging, the purge timer is reset and will not begin counting down until pressure is greater than P3.

NOTE: If enclosure pressure is below P1 when K1 is used to provide power to the enclosure during operation, K1 will remain energized. An alarm is required and must be located so an operator will be notified of the alarm.

Operation Mode

- After the purge timer counts down, SV will shut off and K1 is energized.
- If enclosure pressure drops below P3, the SV is energized and will stay energized for the value of HYST (% , leakage compensation). If HYST is set to 0, then leakage compensation is turned off. However, Program 4 is usually used when a continuous purging through the enclosure is required during operation mode.

- If enclosure pressure drops below P1, K1 remains on and an alarm will sound. K2 can be set to P- or Alarm to indicate below safe or operating pressure.
- If enclosure pressure goes above P4, K1 remains. If K2 is setup as Alarm, then K2 will energize.

7.2.5 Program 5

Program 5 is used in combustible dust atmospheres.

Pre-Purge

- The purge valve (SV) does not come on during this operation. In a dust atmosphere purging is not required, but the enclosure has to be cleaned out of all combustible dust and then pressurized.
- Menu screen will show 'CLEAN ENCLOSURE'. Enclosure should be cleaned and then pressurized before pressing SET button.
- The enclosure pressure has to be above P1 (minimum 0.65" wc / 1.6 mbar for dust atmospheres) in order for the SET button to work.

Operation mode

- After cleaning out and pressurizing the enclosure, the menu will show 'CLEAN ENCLOSURE'. To see the enclosure pressure press Down or Up button. Pressing the SET button will energize K1.
- If enclosure pressure drops below P2, the SV is energized and will stay energized for the value of HYST (% , leakage compensation). If HYST is set to 0, then leakage compensation is turned off. Compensation for leakages is allowed in a dust atmosphere because the enclosure is safe at this point.
- If enclosure pressure drops below P1, K1 remains on and an alarm will sound. K2 can be set to P- or Alarm to indicate below safe or operating pressure.
- If enclosure pressure goes above P4, K1 remains. If K2 is setup as Alarm, then K2 will energize.

Note: If enclosure pressure is below P1 when K1 is used to provide power to the enclosure during operation, K1 will remain energized. An alarm is required and must be located so an operator will be notified of the alarm.

Sequence of events for purging and operation of the 5500 system for all 5 programs

Program	1		2		3		4		5	
purging	K1	SV	K1	SV	K1	SV	K1	SV	K1	SV
P<P1	off	on	off	off	off	off	off	on	off	off
P1<P<P2	off	on	off	on	off	on	off	on	off	off
P2<P<P3	off	on	off	on	off	on	off	on	off	off
P3<P<P4	off	on	off	on	off	on	off	on	off	off
P>P4	off	off	off	off	off	off	off	off	off	off
									Clean activates above P1	
after purging										
P<P1	on	on	on	on	off	off	on	off	on	off
P1<P<P2	on	on	on	on	on	on	on	on	on	on
P2<P<P3	on	off	on	off	on	off	on	on	on	off
P3<P<P4	on	off	on	off	on	off	on	off	on	off
P>P4	on	off	on	off	on	off	on	off	on	off

Note: Shutdown timer, temperature, and bypass will affect status of K1 and SV. Please see explanation of each to determine effects on K1 and SV.

7.3 Purging Timer

MIN:SEC

000:00

To program the purging timer, proceed as follows:

- Calculate the purging time using the formulas and examples in chapter 8 „Determining Purging Time“:
- Enter the purging time using the UP and DOWN buttons and SET.
- To change purging time by one second increments, press the UP or DOWN button once.
- To change purging time faster, hold down the button continuously. Purging time will advance faster, the longer you hold the button down (in 5 seconds, 1 min, 5 min steps).

Maximum purge time is 166:39.

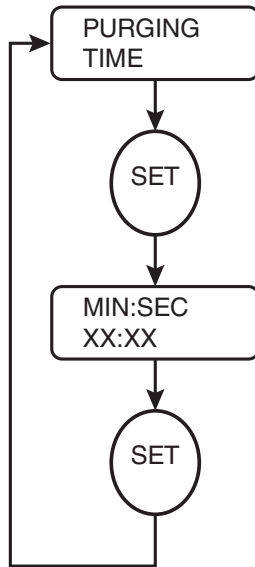

7.4 Minimum enclosure pressure 'P1'

In accordance with the applicable standards and tolerances on the 5500 pressure sensor, the minimum operating pressures are as follows:

- Gas environments: 0.25" wc / 0.7 mbar
- Dust environments: 0.65" wc / 1.6 mbar

When enclosure pressure drops below P1 during operation mode, the power has to be interrupted. If not, an alarm has to be generated to address the problem.

7.5 Alarm pressure 'P2'

If enclosure pressure drops below P2 during operation mode, the solenoid valve will energize until pressure goes above P2+HYST. Therefore, leakage compensation has to be implemented.

If leakage compensation is not used, the P2 can sound an alarm to indicate that pressure is dropping.

P2 can be adjusted to above P1 and Below P3 values.

7.6 Purging pressure 'P3'

The purging timer starts when enclosure pressure is above P3. If the pressure is above P3, purging will start and finish uninterrupted. If the enclosure pressure is below P3, the purging timer will not start. If the pressure drops below P3 during purging, the purging timer will immediately reset to its beginning time and will not start timing down until pressure is above P3. P3 can be adjusted to above P2 and below P4 values.

7.7 Maximum internal pressure 'P4'

If enclosure pressure is above P4, then the display will read 'MAX' to indicate maximum pressure has been achieved. Regardless of the action of the solenoid valve (purging, leakage compensation, temperature) the solenoid valve will de-energize and will not come on until enclosure pressure goes below P4. This action may cause the solenoid valve to oscillate on and off and should be noted as a maximum pressure problem if this happens.

If K1 was on before P4 was reached, it will remain on after enclosure pressure is above P4. P4 is adjusted above P3. Maximum setting is 9.99" wc / 25 mbar.

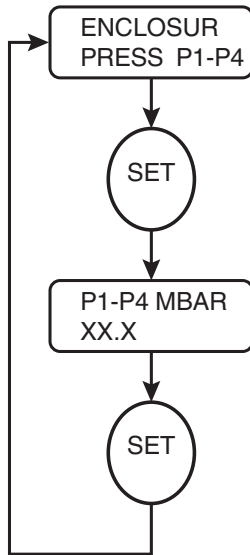

Leakage Compensation hysteresis 'HYST'

In operation mode there may be excess leakage of pressure from the enclosure because a seal or gasket has caused a drop in regulated line pressure (protective gas source). Leakage compensation option allows for the SV to turn on in order to compensate for these unintentional leakages. Depending on the purge program used, the SV will energize when below P2 and will de-energize when it is above P2 + hysteresis.

If leakage compensation is not required, set HYST to '0'.

Values for hysteresis HYST are as following:

Inches of wc	mbar
0	0
0.2	0.5
0.4	1.0
0.6	1.5
0.8	2.0
1.0	2.5
1.2	3.0

1.4	3.5
1.6	4.0
1.8	4.5
2.0	5.0

Example

units are in mbar, hysteresis = 1.5, then SV is on at P2 and turns off at P2 + 1.5

The HYST unit of measurement will be the units being used.

If HYST = 1.5 then this is 1.5 mbar.

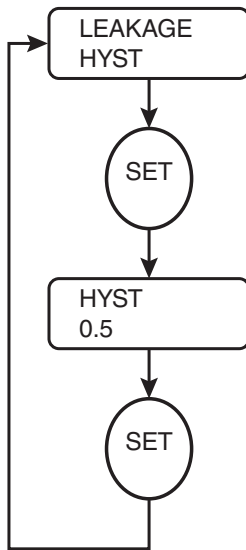

AUTOMATIC LEAKAGE COMPENSATION

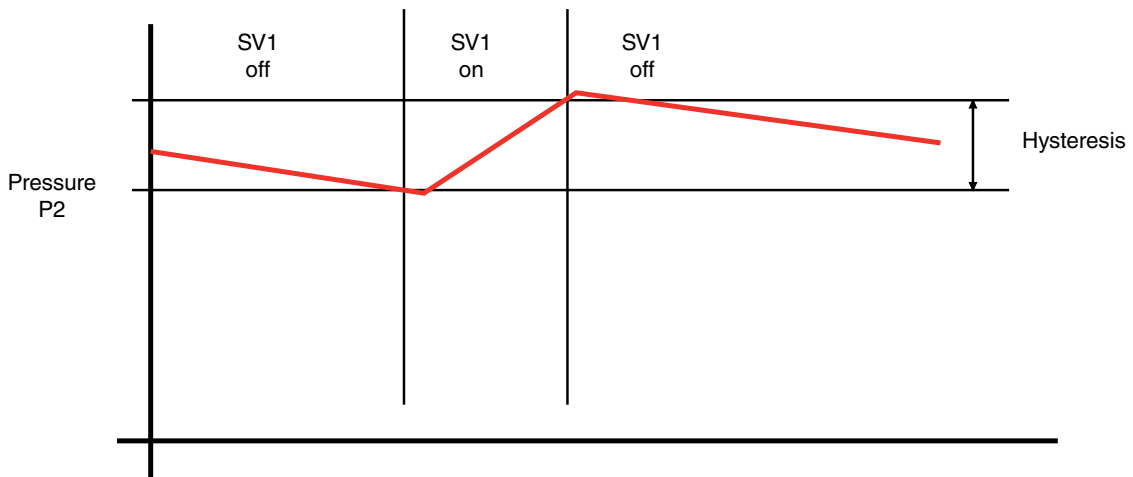

7.8 4.8 Programming K2

The K2 contact output can be programmed for various settings that are chosen by the user.

For Type Z and Ex pz systems, power to the pressurized enclosure can remain on if pressure goes below the minimum allowed pressure but an audible and/or visual alarm must be generated to notify the operator of a problem.

K2 can be used to generate the signal for the alarm.

Below are the following users selectable settings for K2

K1	Switches simultaneously with K1
P1+	Switches on when pressure exceeds P1
P1-	Switches off when pressure falls below P1
P2+	Switches on when pressure exceeds P2
P2-	Switches off when pressure falls below P2
P3+	Switches on when pressure exceeds P3
P3-	Switches off when pressure falls below P3
P4+	Switches on when pressure exceeds P4
P4-	Switches off when pressure falls below P4
FT	Switches on when purge timer starts and shuts off at the end of purging
Temp AL	Switches on K2
Bypass	Switches on when the bypass function is activated
All Alarms	Comes on when P1-, P4, Bypass, Temp AL

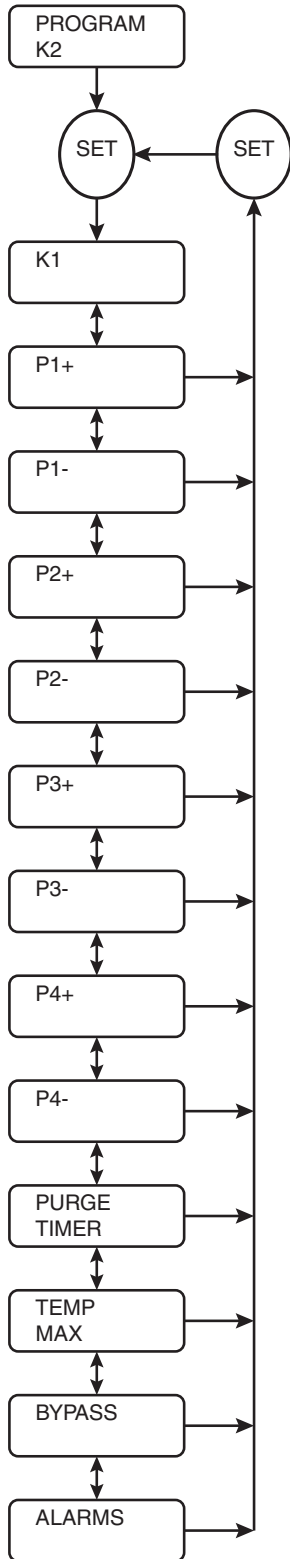

7.9 Shutdown timer for K1

The shutdown timer is used in the operation mode and allows K1 to remain on for the duration of this setting when enclosure pressure drops below the minimum setting of P1. If the pressure goes above P1 during the countdown, the timer is reset. If the pressure remains below P1 for the duration of the countdown, K1 will shut off.

Shutdown timer is effective only for Program 3 where K1 will de-energize when enclosure pressure is below P1. The other programs allow power to the enclosure to remain on when pressure is below P1 but an alarm must be generated to the operator.

Default value is 0 seconds. Range is 0 to 60 seconds.

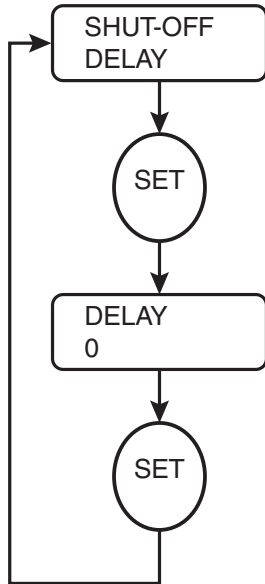

7.10 4.10 Number of PT100 temperature sensors used

The 5500 control unit allows up to two 2-wire PT100s to be connected to the unit for monitoring and controlling temperatures in the pressurized enclosure.

Each sensor can be located up to three meters from the control unit input. Using two PT100s allows various placements within the enclosure to capture the variation of heat in locations where electronic devices are located.

In order for the temperature inputs to work, Number of PT100s and Temperature enabled must be activated. A wrong number of PT100s selected will give a error on the PT100 input, the PT100 LED will light up, and TEMP AL will be activated if selected for K2.

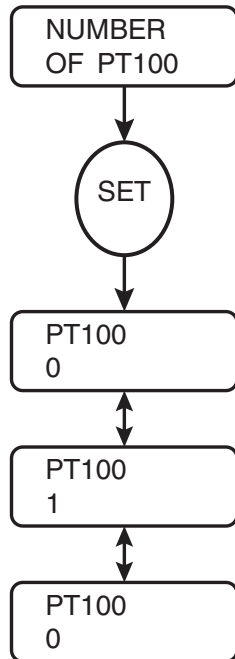

7.11 Temperature inputs PT1 and PT2

To activate this function:

enter the number of PT100s into the menu with the correct number of sensors connected to the input.

- Select ENABLED in the TEMP ENABLED selection menu.
- All values are entered in degrees C. F is not available.

TEMP PT1 SV1, TEMP PT2 SV1

When the temperature on the PT100(s) is greater than the user set value, the SV1 contact is energized. The manifold will be energized and the purge flow will begin to flush out the cabinet to allow for cooling. The SV1 contact remains energized until temperature falls to 3 °C below this set temperature.

TEMP PT1 K2, TEMP PT1 K2

If the temperature within the enclosure continues to increase because the SV1 valve is not efficient enough to cool, this second trip point can be used to activate K2 when K2 is programmed for TEMP AL (temperature alarm). This can be used to control a secondary cooling device or as a warning. K2 (TEMP ALARM) contact remains energized until temperature falls to 3 °C below this set temperature.

TEMP PT1 K1, TEMP PT2 K1

If the temperature rises above this set point. K1 will de-energize and the LCD will display OVER TMP, indicating over temperature. A RESET must be done to get the system to operate again. The RESET will work only when the temperature goes below the user-set temperature value. Depending on the program used, the RESET will cause the system to

re-purge or CLEAN out the enclosure.

Note: If TEMP ENABEL is off, the number of PT100s is '0', and a PT100 is connected to one or both of the inputs, the PT100 LED will turn on. This is to indicate that there is something not correct with the temperature setup of this system. The system will still operate, but the LED will remain illuminated until the issue is corrected.

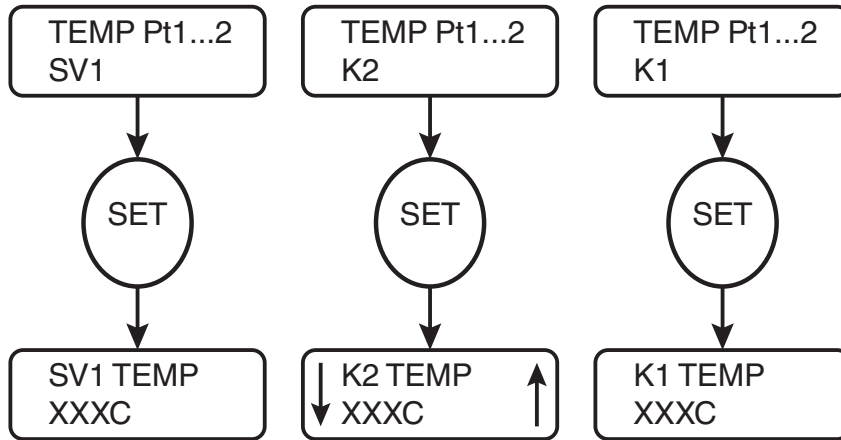

AUTOMATIC TEMPERATURE CONTROL

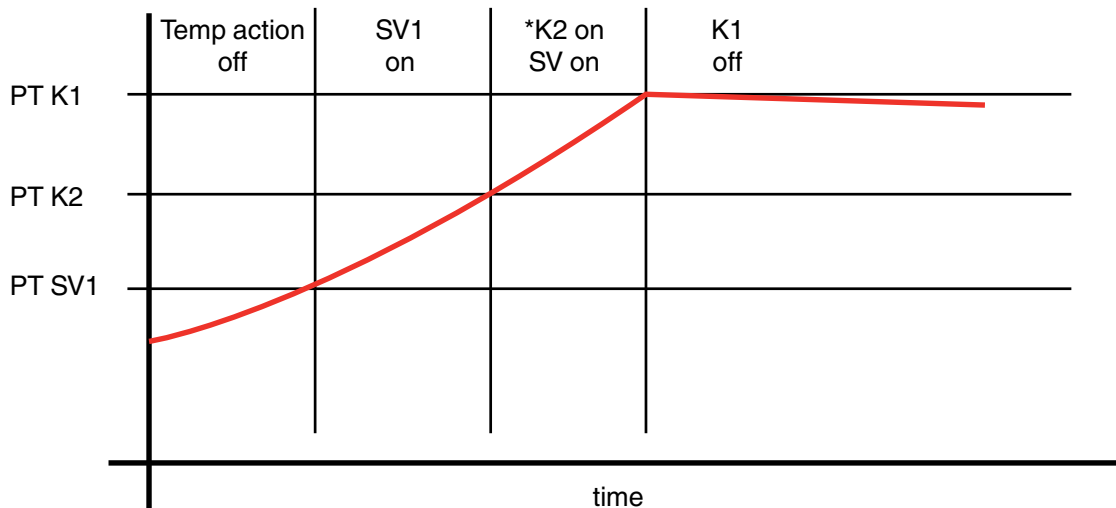

* Note: K2 is mapped to Any Alarm or Temp Max. For above action to take place.

7.12 Bypass

The Bypass mode allows power to the enclosure to be energized when the enclosure pressure is below the minimum pressure P1. This can be useful in commissioning the enclosure or working on the enclosure when it is open.

The Bypass option has three modes of operation to choose from.

Mode		Description
N	No	Bypass is not enabled
Y	Yes	Bypass is implemented using the purge settings menu. By selecting 'Y', the system will go into bypass and will turn on K1. In the 'Y' mode, K1 can be energized before the system goes through a successful purge. This mode can be useful in commissioning the enclosure during start up. This mode is on when it is selected and the menu stays in the purge settings mode. If the user exits from the purge settings mode, then the 'Y' is automatically changed to 'N' and K1 will de-energize. Bypass LED is on
E	External	The bypass is implemented using the HW input on the control unit and is only operational when the enclosure is safe and pressure is above P1. The 'E' mode will not energize K1 if the enclosure is not safe. Bypass LED is on.



Bypass should only be implemented when the area surrounding the pressurized enclosure is known to be safe – non hazardous!

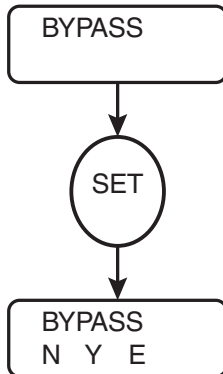

7.13 Units

The units can be changed from 'M' metric to 'I' imperial. This affects the pressure readings and M will read in mbar and I will read in inches of water column. The temperature settings will always be in C.

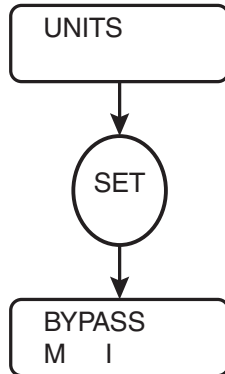

7.14 TEMP ENABLED

TEMP ENABLED allows for temperature alarm/control when ON. TEMP ENABLED and NUMBER OF PT100 has to be selected for temperature alarm/control to be effective. If one is selected and another is not, a TP100 LED fault LED will be on.

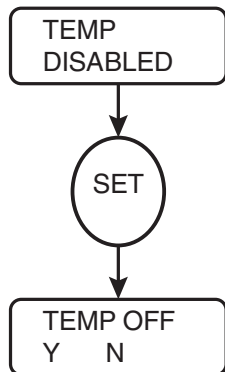

7.15 CHANGE PASSWORD

To change the existing password, use the UP and DOWN buttons for each digit.

- Enter 4 digits.
- To cancel without saving a new password, press RESET. The existing password will still be valid.

Note: There is no confirmation of key strokes when changing the password, so please note what the password is when changing.

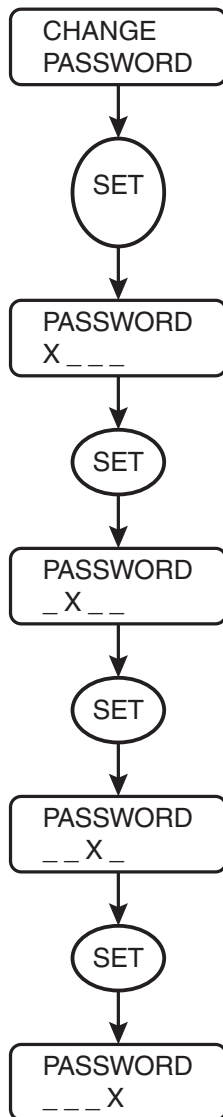

8. Determining Purging Time

To make sure the enclosure is safe from the hazardous atmosphere, the inside of the enclosure has to be free of the hazardous atmosphere and pressurized before the equipment inside can be powered.

The first step in this process is to get rid of the hazardous atmosphere within the enclosure.

For a dust atmosphere, the inside of the enclosure must be cleaned out and then pressurized. Because most vents on a pressurized enclosure have a spark arrestor, purging is not the method used. The dust must be cleaned out manually or with some type of vacuum that is rated for the area or in an area that is not rated when cleaning.

For gas atmospheres, the enclosure is purged by introducing a flow of protective gas (compressed air, or Inert gas) through the enclosure to make it safe. Depending on the standards being used to evaluate the effectiveness of the purging operation, the volume of protective gas through the enclosure will determine the amount of time for purging. The exchange of protective gas is related to the volume of the enclosure, the number of exchanges, and the flow rate through the enclosure.

Below is an equation for determining the purging time:

$$\text{(number of volume exchange) X (volume of the enclosure) / flow rate} = \text{purging time}$$

The number of volume exchange will depend on the item being purged and the standard it is being evaluated:

# of exchanged	NEC	Zone
4	X	n/a
5	n/a	X
10 (motors)	X	X

Example:

P3 =	2.6" H ₂ O	6.5 mbar
Vent =	EPV-5500-...-02 graph for P3: EPV-5500-...-02, 5-15 ft ³ , see section 5.2.2	
Enclosure volume =	10 ft ³	282 liters
Flow Rate from P3 (see graph)	11.3 scfm	320 liters/min
NEC (class/division)	4 volume exch.	4 volume exch.
Zone (ATEX, IECEx)	5 volume exch.	5 volume exch.

NEC:	4 x 10 ft ³ / 11.3 scfm = 3.6 min	4 x 282 liters / 320 l/min = 3.6 min
Zone:	5 x 10 ft ³ / 11.3 scfm = 4.5 min	5 x 282 liters / 320 l/min = 4.5 min
Motors:	10 x 10 ft ³ / 11.3 scfm = 8.9 min	10 x 282 liters / 320 l/min = 8.9 min

The 5500 control unit has a purge timer in the EPC_U and is user selectable through the menu.

The purge timer is activated when the enclosure pressure goes above P3. The pressure must always be above P3 for the timer to continue until it counts down to 000:00. If the enclosure pressure drops below P3 for any amount of time, then the timer is reset to its starting value and will not start counting down until pressure is above P3.

The flow rate for P3 value can be found on the graphs for Vent flow in section 5.2.2 „Flow Rate Curves“. The flow rate for P3 depends on the EPV-5500 vent that is used.

Please note that the more the enclosure leaks pressure, the more flow rate into the enclosure to achieve the P3 threshold.

Maximum purge time allowed on the 5500 system is 166:39 (min:sec)

9. User Parameter Setting Sheet

Display	Description	User Settings
PASSWORD / SET	Password	
PURGE / PROGRAM	Program 1-5	
PURGE / TIME	Time required for purging	
ENCLOSUR / PRESS P1	Shutdown pressure P1	
ENCLOSUR / PRESS P2	Alarm/signal pressure P2	
ENCLOSUR / PRESS P3	Purge pressure P3	
ENCLOSUR / PRESS P4	Maximum pressure P4	
LEAKAGE / HYST	Leakage comp and hysteresis	
PROGRAM / K2	K2 program	
SHUT-OFF / DELAY	Shutdown timer for K1	
NUMBER / OF PT100	Number of PT100's being used	
TEMP PT1 / SV1	SV1 turns on above PT1	
TEMP PT2 / SV1	SV1 turns on above PT2	
TEMP PT1 / K2	K2 turns on above PT1	
TEMP PT2 / K2	K2 turns on above PT2	
TEMP PT1 / K1	K1 turns on above PT1	
TEMP PT2 / K1	K1 turns on above PT2	
BYPASS / N Y E	Bypass	
UNITS / M I	M for metric units, I for imperial units	
TEMP / ENABLED	Temperature monitoring on or off	



10. Type Codes

5 5 0 0 - S S - I - V A C - P S C - L S C

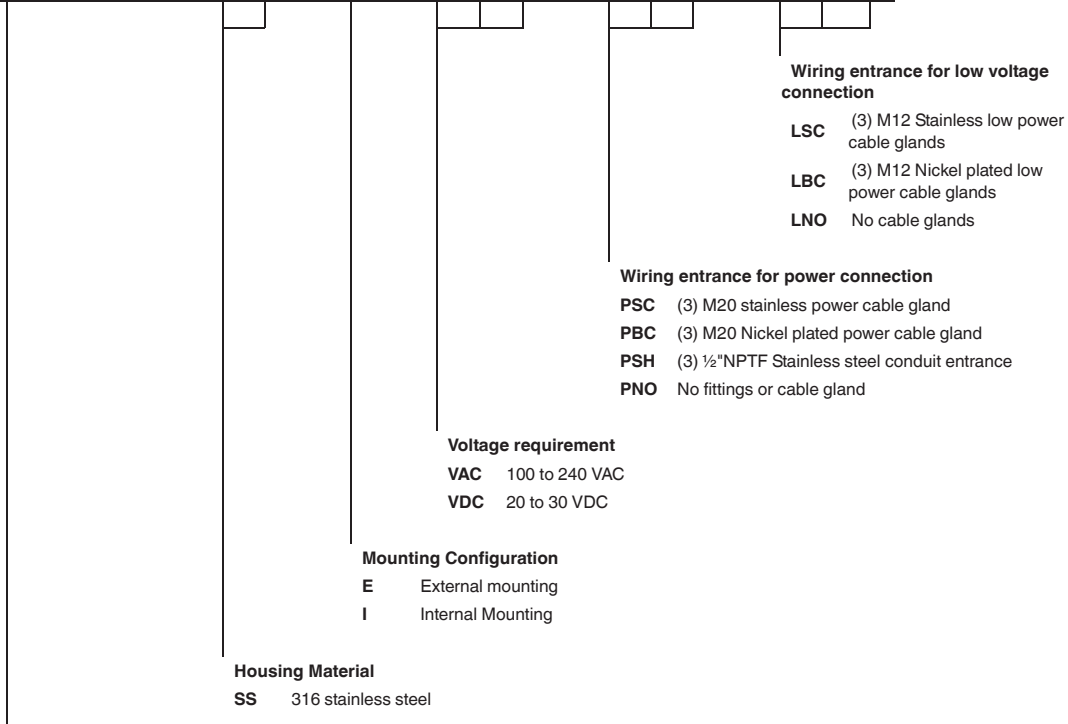

E P V - 5 5 0 0 - A A - 0 1

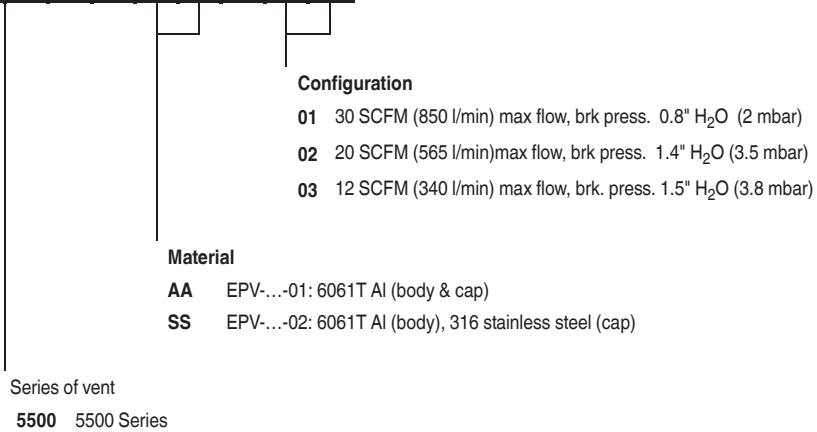



5	5	0	0	-	M	A	N	-	E	X	0	1	-	2	4	V	D	C
---	---	---	---	---	---	---	---	---	---	---	---	---	---	---	---	---	---	---

Voltage Requirement

24VDC
120VAC
230VAC

Type of Approval

EX01 ATEX and IECEx certification
CD01 FM and CSA certification
CDUL UL and CSA certification (different body design),
only 60 Hz for AC models

Valve Type

MAN Manifold (includes purging and pressurization valves)

Type of System

Type Z & Ex pz, Zone 2 & 22, NEC Class I & II / Division 2

11. Certification

11.1 ATEX - UL/DEMKO 14ATEX1282X

11.1.1 External

II 3 G Ex ic nA nC [ic pz IIC Gc] IIC T4 Gc (-20 °C ≤ t_a ≤ +60 °C)

II 3 G Ex ic nA nC [ic pz IIC Gc] IIC T6 Gc (-20 °C ≤ t_a ≤ +40 °C)

II 3 D Ex ic tc [ic pD IIIC Dc] IIIB T80°C Dc (-20 °C ≤ t_a ≤ 60 °C)

II 3 D Ex ic tc [ic pD IIIC Dc] IIIB T60°C Dc (-20 °C ≤ t_a ≤ 40 °C)

11.1.2 Internal

II 3 G Ex ic nA nC [ic pz IIC] IIC T4 Gc (-20 °C ≤ t_a ≤ +60 °C)

II 3 G Ex ic nA nC [ic pz IIC] IIC T6 Gc (-20 °C ≤ t_a ≤ +40 °C)

II 3 D Ex ic tc [ic pD IIIC Dc] IIIC T80°C Dc (-20 °C ≤ t_a ≤ 60 °C)

II 3 D Ex ic tc [ic pD IIIC Dc] IIIC T60°C Dc (-20 °C ≤ t_a ≤ 40 °C)

11.2 IECEx - UL14.0019X

11.2.1 External

Ex ic nA nC [ic pz IIC GC] IIC T4 Gc (-20 °C ≤ t_a ≤ +60 °C)

Ex ic nA nC [ic pz IIC GC] IIC T6 Gc (-20 °C ≤ t_a ≤ +40 °C)

Ex ic tc [ic pD IIIC DC] IIIB T80°C C (-20 °C ≤ t_a ≤ 60 °C)

Ex ic tc [ic pD IIIC Dc] IIIB T60°C DC (-20 °C ≤ t_a ≤ 40 °C)

11.2.2 Internal

Ex ic nA nC [ic pz IIC GC] IIC T4 Gc (-20 °C ≤ t_a ≤ +60 °C)

Ex ic nA nC [ic pz IIC GC] IIC T6 Gc (-20 °C ≤ t_a ≤ +40 °C)

Ex ic tc [ic pD IIIC Dc] IIIC T80°C Dc (-20 °C ≤ t_a ≤ 60 °C)

Ex ic tc [ic pD IIIC Dc] IIIC T60°C (-20 °C ≤ t_a ≤ +40 °C)

11.3 cULus Class Divisions

Class I Division 2 Group A, B, C, D T4 (-20 °C ≤ t_a ≤ +60 °C)

Class I Division 2 Group A, B, C, D T6 (-20 °C ≤ t_a ≤ +40 °C)

Class II Division 2 Group F+G T4 (-20 °C ≤ t_a ≤ 60 °C)

Class II Division 2 Group F+G T6 (-20 °C ≤ t_a ≤ 40 °C)



11.4 Applied Standards

11.4.1 IECEx

IEC 60079-0

IEC 60079-2

IEC 60079-11

IEC 60079-15

IEC 60079-31

IEC 61241-4

11.4.2 ATEX

EN 60079-0

EN 60079-2

EN 60079-11

EN 60079-15

EN 60079-31

EN 61241-4

11.5 Certification Markings

11.5.1 Control Unit

PEPPERL+FUCHS
Twinsburg, OH 44087 / www.pepperl-fuchs.com

Model 5500-SS-I-VAC-xxx-xxx
Type Z / Ex pz **PN: 51xxxx**

Class I, Division 2, Groups A, B, C, D T4 (-20°C ≤ Ta ≤ 60°C)
Class I, Division 2, Groups A, B, C, D T6 (-20°C ≤ Ta ≤ 40°C)
Class II, Division 2, Groups F+G T4 (-20°C ≤ Ta ≤ 60°C)
Class II, Division 2, Groups F+G T6 (-20°C ≤ Ta ≤ 40°C)

Type 4X, IP66, UL file E184741

II 3 G Ex ic nA nC [ic pz IIC Gc] IIC T4 Gc (-20°C ≤ Ta ≤ 60°C)
II 3 G Ex ic nA nC [ic pz IIC Gc] IIC T6 Gc (-20°C ≤ Ta ≤ 40°C)
II 3 D Ex ic tc [ic pD IIIC Dc] IIIC T80°C Dc (-20°C ≤ Ta ≤ 60°C)
II 3 D Ex ic tc [ic pD IIIC Dc] IIIC T60°C Dc (-20°C ≤ Ta ≤ 40°C)
UL/DEMKO 14ATEX1282X, IP66

Ex ic nA nC [ic pz IIC Gc] IIC T4 Gc (-20°C ≤ Ta ≤ 60°C)
Ex ic nA nC [ic pz IIC Gc] IIC T6 Gc (-20°C ≤ Ta ≤ 40°C)
Ex ic tc [ic pD IIIC Dc] IIIC T80°C Dc (-20°C ≤ Ta ≤ 60°C)
Ex ic tc [ic pD IIIC Dc] IIIC T60°C Dc (-20°C ≤ Ta ≤ 40°C)
IECEX UL 14.0019 X, IP66

PURGE CONTROL FOR USE IN HAZARDOUS LOCATIONS
IN ACCORDANCE WITH THE NATIONAL FIRE PROTECTION
ASSOCIATION STANDARD FOR PURGED AND PRESSURIZED
ENCLOSURES FOR ELECTRICAL EQUIPMENT NFPA 496-2013.

Power Requirement, CAT II:
100 to 240 VAC / 0.05A / 48-62 Hz
F1 = 0.08A F2 = 2.0 A
K1: 6A@250VAC resistive load, 2A@30VDC
K2: 2A@250VAC resistive load, 2A@30VDC

 WARNING - EXPLOSION HAZARD - DO NOT DISCONNECT WHILE CIRCUIT IS LIVE
UNLESS AREA IS KNOWN TO BE NON-HAZARDOUS
WARNING - EXPLOSION HAZARD - SUBSTITUTION OF COMPONENTS MAY IMPAIR
SUITABILITY FOR CLASS I, DIVISION 2
WARNING - POTENTIAL ELECTROSTATIC CHARGING HAZARD - SEE
INSTRUCTIONS

AVERTISSEMENT - RISQUE D'EXPLOSION NE PAS DEBRANCHER TANT QUE LE
CIRCUIT EST SOUS TENSION À MOINS QU'IL NE S'AGISSE D'UN EMPLACEMENT
NON DANGEREUX
AVERTISSEMENT - RISQUE D'EXPLOSION - LA SUBSTITUTION DE COMPOSANTS
PEUT RENDRE CE MATÉRIEL INACCEPTABLE POUR LES EMPLACEMENTS DE
CLASSE I, DIVISION 2
AVERTISSEMENT - POTENTIEL ELECTROSTATIQUE CHARGE DANGER
VOIR LES INSTRUCTIONS

See 116-B026 for Installation information including non-incendive connections

MADE IN USA -20°C ≤ Ta ≤ 60°C **BEBCO EPS**

11.5.2 EPV-5500 Vent Unit

PEPPERL+FUCHS
 Twinsburg, OH 44087 / www.pepperl-fuchs.com

Model EPV-5500-AA-03
Type Z / Ex pz PN: 515664

 Enclosure
 TYPE 4X

4S11 cULus E184741

Part of DEMKO 14ATEX1282X
 Part of IECEx UL 14.0019X

This device is part of UL Classified
 apparatus Type 5500 Purge System

MADE IN USA $-20^{\circ}\text{C} \leq T_a \leq 60^{\circ}\text{C}$ **BEBCO EPS®**

12. Troubleshooting

Problem	Possible Reason	Solution
Purge cycle does not start	No air to system	Check air supply, make sure minimum pressure available
	Minimum pressure not high enough	Check vent and enclosure seals, check compensation valve setting.
	Control Unit in dust mode	Program 5 was used instead of programs 1-4. Select proper program

PROCESS AUTOMATION – PROTECTING YOUR PROCESS



For over a half century, Pepperl+Fuchs has provided new concepts for the world of process automation. Our company sets standards in quality and innovative technology. We develop, produce and distribute electronic interface modules, Human-Machine Interfaces and hazardous location protection equipment on a global scale, meeting the most demanding needs of industry. Resulting from our world-wide presence and our high flexibility in production and customer service, we are able to offer complete individual solutions – wherever and whenever you need us. We are the recognized experts in our technologies – Pepperl+Fuchs has earned a strong reputation by supplying the world's largest process industry companies with the broadest line of proven components for a diverse range of applications.



1 Worldwide/German Headquarters
Pepperl+Fuchs GmbH
Mannheim · Germany
Tel. +49 621 776 2222
E-Mail: pa-info@de.pepperl-fuchs.com

2 Asia Pacific Headquarters
Pepperl+Fuchs PTE Ltd.
Singapore
Company Registration No. 199003130E
Tel. +65 6779 9091
E-Mail: pa-info@sg.pepperl-fuchs.com

3 Central/Western Europe & Africa Headquarters
Pepperl+Fuchs N.V.
Schoten/Antwerp · Belgium
Tel. +32 3 6442500
E-Mail: pa-info@be.pepperl-fuchs.com

4 Middle East Headquarters
Pepperl+Fuchs M.E (FZE)
Dubai · UAE
Tel. +971 4 883 8378
E-Mail: pa-info@ae.pepperl-fuchs.com

5 North/Central America Headquarters
Pepperl+Fuchs Inc.
Twinsburg · Ohio · USA
Tel. +1 330 486 0002
E-Mail: pa-info@us.pepperl-fuchs.com

6 Northern Europe Headquarters
Pepperl+Fuchs GB Ltd.
Oldham · England
Tel. +44 161 6336431
E-Mail: pa-info@gb.pepperl-fuchs.com

7 Southern/Eastern Europe Headquarters
Pepperl+Fuchs Elcon srl
Sulbiate · Italy
Tel. +39 039 62921
E-Mail: pa-info@it.pepperl-fuchs.com

8 South America Headquarters
Pepperl+Fuchs Ltda.
São Bernado do Campo · SP · Brazil
Tel. +55 11 4341 8448
E-Mail: pa-info@br.pepperl-fuchs.com

www.pepperl-fuchs.com

 **PEPPERL+FUCHS**
PROTECTING YOUR PROCESS