

Low Voltage Power & Insulated Case Circuit Breakers Section 8

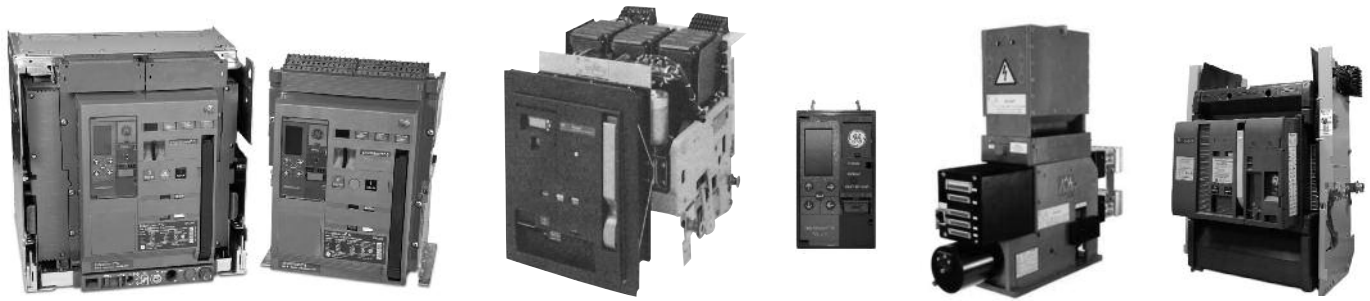

Low Voltage Power and DC Circuit Breakers

EntelliGuard™ G Low Voltage Power Circuit Breakers	8-2
Overview and Functions	8-2
EntelliGuard™ TU Trip Units	8-4
Product Nomenclature	8-5
Cassettes Nomenclature	8-11
Accessories	8-13
WavePro Circuit Breakers with EntelliGuard™ TU, Power+, Enhanced MicroVersaTrip™ Plus and MicroVersaTrip™ PM Trip Unit Systems	8-24
WavePro Low Voltage Power Circuit Breakers	8-26
OEM Substructures and Substructure Accessories	8-40
Trip Units	8-49
Overview – EntelliGuard™ TU, Power+ and Enhanced MicroVersaTrip™	8-49
Product Number Nomenclature System	8-55
Trip Unit Conversion Kits Introduction	8-66
Overview – EntelliGuard™ TU, and MicroVersaTrip™ PM Conversion Kits	8-67
Remanufactured MVT Trip Unit Overview and Features	8-69
ProTrip™ Trip Unit Conversion Kits Selection Guide	8-70
ProTrip™ Rating Plugs	8-74
EntelliGuard™ TU Trip Unit Conversion Kits Selection Guide	8-76
EntelliGuard™ TU Trip Rating Plugs	8-80
EntelliGuard™ TU Trip Unit Conversion Kit Accessories and Hardware	8-81
Trip Unit Accessories	8-83
Asbestos Free Arc Quencher Replacement Kits	8-85
Gerapid High Speed DC Circuit Breakers	8-86
Features and Benefits	8-86
Technical Data	8-88
Outline Drawings and Dimensions	8-89

Insulated Case Circuit Breakers

Power Break™ II	8-91
Features	8-91
Construction Options	8-92
EntelliGuard™ TU Trip Unit Features	8-93
Power+ Trip Unit Features	8-94
Enhanced MicroVersaTrip™ Trip Unit Features	8-95
Trip Unit Characteristics	8-96
Power Break™ II Nomenclature System	8-99
Product Number Nomenclature System	8-104
Interrupting Capacity and Withstand Ratings	8-108
How to Order	8-109
Frame Selection (Old Structure)	8-110
Trip Unit Selection	8-111
Enhanced MicroVersaTrip™ Rating Plug Selection	8-113
Stationary and Draw-out Switch Selection	8-114
Stationary and Draw-out Breaker Accessories	8-115
Stationary Breaker Mounting Kits	8-121
Stationary Breaker Mounting Kits, Wall Mounted Enclosures, Floor Mounted Enclosures	8-122
Neutral Current Sensors and POWER LEADER™ Accessories	8-123
Draw-out Breaker Accessories	8-124
Reference Publications	8-126

Visit GE Industrial Solutions website for ordering low voltage power and insulated case circuit breakers and accessories at:
www.geindustrial.com/industrialsystems/wizards/peb_oem_am/home.htm



Low Voltage Power & Insulated Case Circuit Breakers Section 8

EntelliGuard™ G Low Voltage Power Circuit Breaker

Overview and Functions

EntelliGuard™ G Circuit Breakers

EntelliGuard™ G Circuit Breakers are the newest top of the line circuit breakers designed to meet the demands of today's electrical distribution systems by providing ultimate system performance without sacrificing safety or reliability. EntelliGuard™ G devices are available in standard, 100% rated, ANSI/UL1066, UL489 and IEC ratings. Breakers are offered to OEMs in 3 and 4 pole designs from 400A to 6000A (UL/ANSI) or up to 6300A (IEC) with fault interruption ratings up to 150kA and many field-installable accessories. EntelliGuard™ G 3-pole breakers are the standard in GE AKD-20 Low Voltage Switchgear suitable for 280Vac and 600Vac. The breakers are suitable for 280Vac, 480Vac and 600Vac applications, and they provide advanced circuit protection, limit arc fault energy and preserve system coordination without sacrificing any of these critical functions.

Standard Functions

The EntelliGuard™ G Circuit Breakers offer operational safety with functions such as:

Closing and opening - can be initiated remotely or via the front cover push buttons. An Open-Close-Open cycle is possible without recharging.

Breaker/Main Contact Status - OPEN/CLOSED, ON/OFF indication is provided on the front cover.

Through-Door Racking - The breaker racking mechanism is accessible through the front door and permits safely disconnecting/withdrawing the circuit breaker without opening the door and exposing personnel to live parts during the process.

Ready to Close Indicator - Provides visible indication/readiness for close operation.

Breaker Status Indicators - Standard Indicators include:

- The breaker status indicator shows the condition of the main contacts (OPEN, CLOSED).
- The status of the closing springs is indicated as CHARGED or DISCHARGED.
- The draw-out position indicator displays whether the breaker is in the CONNECT, TEST or DISCONNECT position.
- The breaker also includes a switch that provides main contact status indication to the POWER LEADER™ Power Management System.
- The optional Reduced Energy Let-Through (RELT) is provided with an ON/OFF contact closure to positively indicate whether the RELT setting is enabled or not.

Rejection Feature - A factory-installed rejection feature prevents mismatching breakers and cassettes/substructures.

EntelliGuard™ G breakers are designed for flexibility and superiority with functions such as:

Short Time Rating - Up to 100kA for 0.5 sec.

Short Circuit/High Interruption Rating - 150kA at 600V, 100kA at 690V.



Two-Step Stored Energy Mechanism - Breaker operates via stored energy mechanisms that can be manually charged (MO) or electrically charged (EO) by the Spring Charging Motor. Closing time is less than five cycles.

Reverse Feed - EntelliGuard™ G devices can be fed from top or bottom terminals.

Coils - EntelliGuard™ G devices have provisions for four accessory operating coils. The four positions can be filled by the following four devices: one Close Coil (CC or CCC), one Shunt Trip Coil, one UVR (Under Voltage Release), and the fourth position can either be a Shunt Trip Coil or a UVR.

Motor Operator Heavy Duty, Motor/Gearbox Unit - easily accessible.

Interlocks - Standard interlocks include:

- Drawout Breaker
- Drawout Breaker/Main Contacts
- Spring Discharge Interlock

Padlocking Devices - The padlocking device is standard on breakers and allows up to three padlocks with 1/4" to 3/8" diameter shanks to secure the breaker in the OPEN/TRIP FREE position.

Thermal Performance - ANSI C37 and UL 489 designs are 100% rated up to 40°C when applied in recommended enclosure sizes. IEC 60947 versions are 100% rated in free air up to 50°C. IP31 enclosure/switchboard rating is based on size, recommended up to 50°C ambient with rear vertical bus connection.

Field Installable Trip Units and Accessories Field - installable accessories are common to all breaker envelopes and frames. Optionally, accessories are also factory mountable.



Low Voltage Power & Insulated Case Circuit Breakers

Section 8

EntelliGuard™ G Low Voltage Power Circuit Breaker

Functions

Optional Functions

EntelliGuard™ G Circuit Breakers offer many optional functions in order to enhance and facilitate the use of the circuit breaker. Those functions include:

Auxiliary Switches - (Optional) Four available designs:

- Power rated (3NO+3NC)
- Power rated (3NO+3NC) + low signal (Hi-Fi) (2NO+2NC)
- Power rated (8NO+8NC)
- Power rated (4NO+4NC) + low signal (Hi-Fi) (4NO+4NC)

Key Interlock - Up to four optional key interlocks are available (Kirk, Ronis, Profalux, Castell). Switchgear applications utilize a Kirk key interlock mounted in the cassette. A maximum of two key interlocks may fit in the cassette.

Mounting Straps/Accessories Kits - are available to mount and connect fixed/stationary breakers.

Optional Lockable Shutters - are available (factory installed).

Carriage Position Switch - This optional cassette/substructure device permits local or remote indication of the circuit breaker status (CONNECTED, TEST, DISCONNECTED), 2NO/2NC single pole, double throw contacts are available for each position.

Lifting Truck - Optional lifting tool with separate slings is available for all breaker sizes.

Optional IP Covers - IP54 covers (protected against harmful amounts of dust and splashing water) are available for all breaker sizes.

Mechanical Counter - Provides local record of the cumulative number of complete breaker closing operations.

Cable Interlocks - (OEM Applications Only) Available for fixed and draw-out breakers, these units enable direct interlocking of EntelliGuard™ G circuit breakers.

Bell Alarm Contact - Available with or without a mechanical lock-out feature, the bell alarm operates when the trip unit issues a trip command.

EntelliGuard™ G circuit breakers with EntelliGuard trip units can be part of an ArcWatch™ solution.

GE's ArcWatch™ system solution involves a combination of intelligent trip units and current limiting molded case circuit breakers to create a no compromise solution; safety and reliability together. Advances in zone selective interlocking (ZSI) and waveform recognition algorithms allow entire systems to be designed so that full selectivity and 100% instantaneous protection at calculated arcing current is possible. For most industrial systems, the GE ArcWatch™ solution will result in incident energy under 8 cal/cm² at 18".

Enabling ArcWatch™ means the proper coordination analysis techniques have been used to determine the necessary circuit breaker protection features and settings that allow full coordination in the given system. The circuit breaker must be set to match the results of the completed study.

For more information, check out www.geindustrial.com/ArcWatch (Publication DET-760) or contact your local sales representative.



Low Voltage Power & Insulated Case Circuit Breakers Section 8

EntelliGuard™ G Low Voltage Power Circuit Breaker

EntelliGuard™ TU Trip Units

EntelliGuard™ TU Trip Units

EntelliGuard™ TU Trip Units enable the EntelliGuard™ G circuit breaker with advanced technology and superior circuit protection without compromising selectivity or arc flash protection.

EntelliGuard™ TU series trip units are available as the standard controller for new production EntelliGuard™ G ANSI/UL 1066, UL 489 and IEC circuit breakers.

These cutting edge trip units provide Zone Selective Instantaneous Protection, Waveform capture, Reduced Energy Let Through Instantaneous Trip and are designed to supply communications for Modbus or Profibus protocols.

Note: See page 8-49 for more information about the EntelliGuard™ TU Trip Unit.

Accessories

There are more than 20 different types of factory or field installed accessories available for the EntelliGuard™ G circuit breaker. Whether it's a bell alarm contact, key interlock or redundant shunt trips, GE has the accessory combinations to meet your need!

Factory-Installed Accessories

- Motor Operators
- Closing Devices
- Shunt Trip for Ground Fault
- UVR with Fixed Time Delay
- Second Shunt Trip or UV Release
- Auxiliary Switches and Contacts
- Bell Alarm and Trip Annunciation
- Bell Alarm Contact
- Trip Annunciation
- Breaker Mounted Key Interlocks
- Mechanical Interlocks- Fixed Breakers
- Mechanical Interlocks – Drawout Breakers

Accessories for Field Installation

- Carriage Position Switch
- Coil Signaling Contact Module
- Contact Wear Indicator
- Door Interlock
- Electrical Close Switch
- Lock Kits
- Lifting Truck
- Mechanical Operation Counter
- Pushbutton Padlock Device
- Ready-to-Close Switch
- Secondary Disconnect Block
- Spring Charged Contact
- UVR Time Delay Module

Note: See page 8-15 for more information about the accessories available for EntelliGuard™ G Circuit Breakers.



EntelliGuard™ G Circuit Breaker

EntelliGuard™ G Circuit Breaker Nomenclature

EntelliGuard™ G Circuit Breaker Product Number Structure

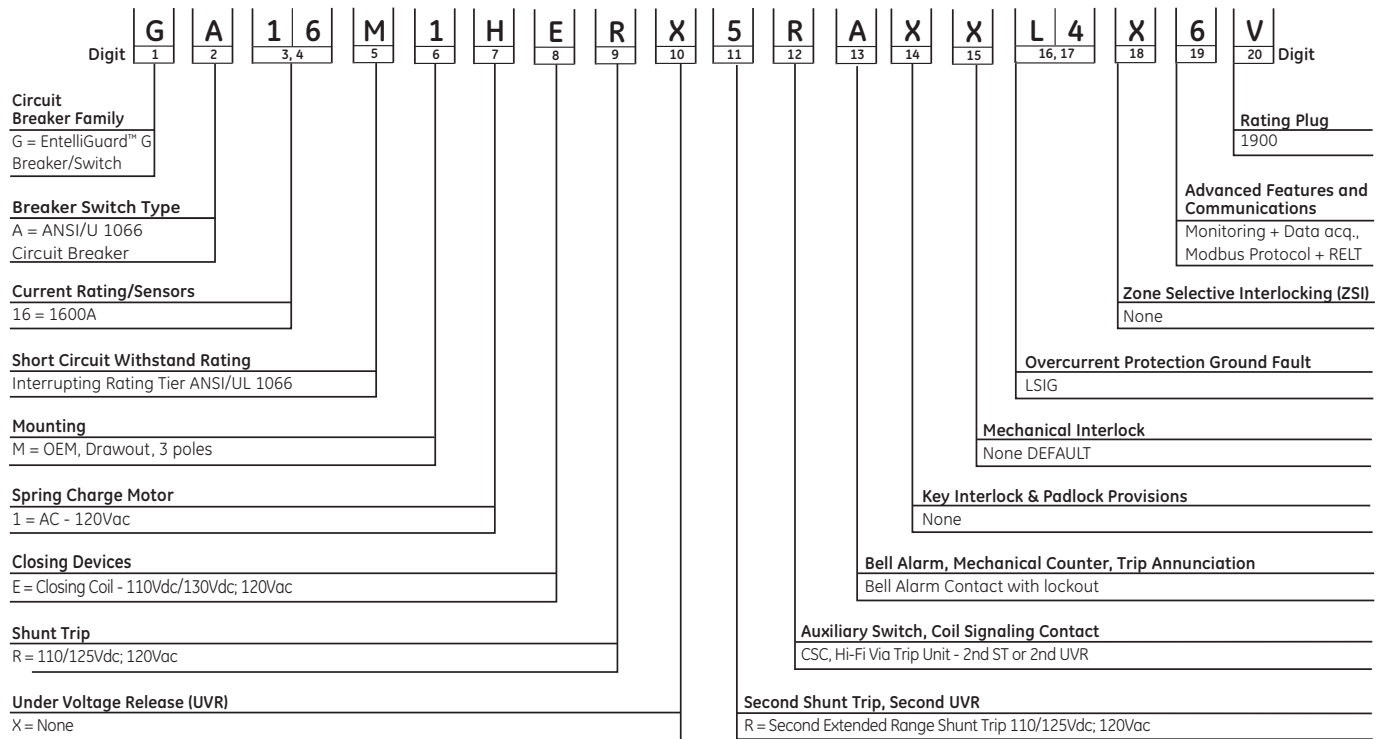

Digit 1 Circuit Breaker Family

Device Series Line	Code
EntelliGuard™ G Breaker/Switch	G

Digit 2 Breaker Switch Type

Breaker/Switch Type, Secondary Mounting	Envelope 1		Envelope 2 & 3
	Side	Top	Top
ANSI/UL1066 Circuit Breaker	A	N	A
UL 489 Circuit Breaker	B	U	B
ANSI Non-auto CB (ANSI Switch)	C	M	C
UL489 Non-auto CB (UL Switch)	D	S	D

Top = Top Mounted Secondary Disconnects (TSD).

Side = Side Mounted Secondary Disconnects (SSD). (Available on Envelope 1 only.)

NOTE: N, U, M, S characters are for Envelope 1 only with top mounted secondary disconnects (TSD).

When ordering codes A, B, C, D, Side Secondary Disconnects (SSD) are supplied as standard on Envelope 1.

Codes N, U, M, S are not valid for Envelopes 2 and 3.

Envelope 1 (Type N and H, 400A - 2000A).

NOTE: DC Ratings; trip unit not included. DC Rated Circuit Breakers require external control devices (e.g., Type 37 or Type 76 DC Relays).

NOTE: Side Secondary Disconnects are specifically intended for 5-High ("high density") equipment designs.

With Side Mounted Disconnects (SSD), the following Aux. Switches are not valid (In Digit 12): Auxiliary Switch, 8NO+8NC (Power Rated) or Aux. Switch, 4NO/4NC (Power Rated) + 4NO/4NC (High Fidelity).

Digits 3 and 4 Current Rating / Sensor

Current Sensor Rating (A)	Circuit Breaker		Switches ¹	
	ANSI	UL489	ANSI	UL489
400	04	04	-	-
600	-	06	-	-
800	08	08	08	08
1000	-	10	-	-
1200	-	12	-	12
1600	16	16	16	16
2000	20	20	20	20
2500	-	25	-	25
3000	-	30	-	30
3200	32	-	32	-
4000	40	40	40	40
5000	50	50	50	50
6000	-	60	-	60

¹Switches (Digit 2 = M, S, C, D) do not have current Sensors or a trip unit



EntelliGuard™ G Circuit Breaker

EntelliGuard™ G Circuit Breaker Nomenclature

Digit 5 Short Circuit Withstand Ratings

Interrupting Rating Tier ANSI/UL1066 Devices, LVPCB								Envelope 1		Envelope 2		Envelope 3		
Code	254V	580V	635V	Withstand	HSIOC	Override No. 1	Override WI	Code	400-1200	400-2000	3200	400-3200	3200	4000-5000
S	65,000	65,000	50,000	50,000	50,000	49,000	53,500	S	X					
N	65,000	65,000	65,000	65,000	None	None	None	N		X	X			
H	85,000	85,000	65,000	65,000	65,000	63,700	69,500	H		X				
P2	100,000	100,000	65,000	65,000	65,000	63,700	69,500	P		X				
E	85,000	85,000	85,000	85,000	None	None	None	E				X		
M	100,000	100,000	100,000	85,000	85,000	83,800	90,950	M				X		X
B	100,000	100,000	100,000	100,000	None	None	None	B					X	X
L	150,000	150,000	100,000	100,000	100,000	98,000	107,000	L					X	X

Interrupting Rating Tier UL489 Devices ICCB								Envelope 1		Envelope 2		Envelope 3		
Code	240V	480V	600V	Withstand	HSIOC	Override No. 1	Override WI	Code	400-1200	400-2000	2500-3000	400-3000	3000	4000-6000
S	65,000	65,000	50,000	42,000	42,000	N/A	44,940	S	X					
N	65,000	65,000	65,000	42,000	42,000	N/A	44,940	N		X	X			
H	85,000	85,000	65,000	50,000	50,000	N/A	53,500	H		X	X			
P2	100,000	100,000	65,000	50,000	50,000	N/A	53,500	P		X				
M	100,000	100,000	100,000	65,000	65,000	N/A	69,550	M				X		X
L	150,000	150,000	100,000	85,000	85,000	N/A	90,950	L					X	X

Close and Latch Ratings (MCR set accordingly)

UL/ANSI 1	42,000	UL/ANSI CB MCR setting determined base on Envelope only. For Retrofill's (A = 17,000, B = 33,000, N = 42,000)			
UL/ANSI 2	65,000	S	N	H	M
UL/ANSI 3	100,000	E	L		
IEC 1	42,000	42,000	42,000		
IEC 2		50,000	50,000	65,000	65,000
IEC 3				100,000	100,000

Notes: Override has 7% pick up tolerance. Nominal setting is 98% of I_{cw} if no other instantaneous is on, or 107% of I_{cw} if any other instantaneous is on. UL 489 CB always have other instantaneous protection on. MCR set at 78% Close and Latch rating with a -10% tolerance. 6000A UL 489 CB is 100% rated as stationary and 80% rated draw-out.

ANSI Non-Automatic Switches			30 Cycle Withstand Ratings		Envelope 1		Envelope 2		Envelope 3	
Code	254V	580V	635V		Code	800-2000	800-3200	3200-5000		
N	42,000	42,000	42,000	1.	N	X				
M	65,000	65,000	65,000		M		X			
B	100,000	100,000	100,000		B				X	

UL489 Non-Automatic Switches			30 Cycle Withstand Ratings		Envelope 1		Envelope 2		Envelope 3	
Code	240V	480V	600V		Code	800-2000	800-3000	3000-6000		
N	42,000	42,000	42,000	1.	N	X				
M	65,000	65,000	65,000		M		X			
B	150,000	150,000	100,000		B				X	

¹ Non-automatic switches are provided with no internal sensing or tripping mechanism and cannot be applied above their respective withstand levels. If non-automatic device is required at ratings above the available switches required, it is recommended that a circuit breaker set with maximum setting be employed using external control or protection as required by the application

² P frame available as 3-pole only

Note: IEC Ratings are also available upon request.

UL489B Ratings Suitable for use in Photovoltaic system in accordance with article 690 of the NEC

Envelope	Type	Amps	Short Interrupting Current (kA)	Rated Endurance		
				Minimum Mechanical Endurance	Minimum Electrical Endurance at 600Vdc	Minimum Electrical Endurance at 1000Vdc
2	M	800-3000	30	12500	500	500

Four configurations available for 600Vdc and 1000Vdc with or without isolating both DC legs.

Note: Bus Bars must be ordered separately

Time Constant (L/R) = 15msec, Rated calibration temperature 50°C.

Note: See EntelliGuard™ G Circuit Breaker Configurator for pricing. Contact a sales representative for configurator.



Low Voltage Power & Insulated Case Circuit Breakers Section 8

EntelliGuard™ G Circuit Breaker

EntelliGuard™ G Circuit Breaker Nomenclature

Digit 6 Mounting

Designation	Mounting	Poles	Code
OEM	Drawout	3	1
		4, right	2
		4, left	3
	Stationary	3	4
		4, right	5
		4, left	6
GE Equipment	Drawout	3	D
	Stationary	3	F

NOTE: Right, Left indicates the location of the fourth pole, typically used to switch the Neutral.

NOTE: 800A Envelope 2 (E, M Ratings) are not available in 4-pole design.

NOTE: P frame available as 3-pole only

Digit 7 Spring Charge Motor

Spring Charge Motor Electrically Operated (EO)	Code
24/30Vdc	A
48Vdc	B
60Vdc	C
72Vdc	D
110/130Vdc	E
250Vdc	F
48Vac	G
120Vac	H
240Vac	J
277Vac	K
Blank/None ¹	X

¹An "X" (Blank/None) denotes a Manually Operated device (MO)

Spring Charge Contact, GSCC1, included with all Motor Operators.

NOTE: When a Spring Charging Motor is selected, a Closing Device must be selected from Closing Devices for Digit 8, and a Shunt Trip Device must be selected from Shunt Trip 1 Devices for Digit 9.

Shunt Trip 1 with a coil voltage different from the Spring Charge Motor may be user-selected.

When a Motor & Spring Charge Contact is selected, the Ready To Close (RTC) (Digit 13) contact output options to the SD (Codes 1, 2, D, E, G, H, K, L) will be wired to the Spring Charge Contact location on the Secondary Disconnect Block.

Digit 8 Closing Devices

Closing Coil Type	Code	
Closing Coil (CC) ²	24Vdc	A
	30Vdc	B
	48Vac/dc	C
	60-72Vdc	D
	110Vdc/130Vdc; 120Vac	E
	208Vac	F
	220Vdc; 240Vac	G
	250Vdc; 277Vac	H
Command Operated Closing Coil (CCC) ³	24Vdc	M
	30Vdc	N
	48Vac/dc	P
	60-72 Vdc	Q
	110Vdc/130Vdc; 120Vac	R
	208Vac	S
	220Vdc; 240Vac	T
	Blank/None	X

²The Closing Coil (CC) permits either local or remote release of the spring charged closing mechanism by electrical operation.

³The Command Operated Closing Coil (CCC) includes an additional anti-pumping safety feature to ensure that the electrical closing signal must be released before further closure is attempted, a shut off is initiated if the closing signal is maintained.

NOTE: Manual button through breaker cover is included as standard assembly.

NOTE: When a Spring Charging Motor is selected (Digit 7), a Closing Device must be selected from Closing Devices for Digit 8, and a Shunt Trip Device must be selected from Shunt Trip 1 Devices for Digit 9.

SELECT ONE DEVICE ONLY.

Digit 9 Shunt Trip

Extended Range Shunt Trip (ANSI/UL) ⁴	Code
24Vdc	M
48Vac/dc	P
70-72Vdc	Q
110/125Vdc; 120Vac	R
208Vac	S
220Vdc; 240Vac	T
250Vdc; 277Vac	V
Blank/none	X

⁴The Extended Range Shunt Trip is specifically intended and required for UL ANSI Ground Fault applications. The pick up range is 55-110% of the ST coil voltage.

When a motor is selected from the Spring Charging Motor (Digit 7) a Shunt Trip must be selected.

SELECT ONE DEVICE ONLY.

Digit 10 Under Voltage Release (UVR)

UVR with Fixed Time Delay ⁵	Code
24Vdc	1
30Vdc	2
48Vac/dc	3
60-72Vdc	4
110/130Vdc; 120Vac	5
208Vac	6
220Vdc; 240Vac	7
250Vdc; 277Vac	8
Blank/none	X

⁵The UVR Shunt Trip with Fixed Time Delay is specifically intended for applications where a delay period ('ride-through') is required due to potential voltage events. The design delays are 50msec when system voltage drops to 50% and 20 msec when system voltage drops below 50%.

An optional External UVR Time Delay Module is available in a 1 - 3sec delay.

SELECT ONE DEVICE ONLY.



EntelliGuard™ G Circuit Breaker

EntelliGuard™ G Circuit Breaker Nomenclature

Digit 11 Second Shunt Trip, Second UVR

	Type	Code
Second UVR with Fixed Time Delay ¹	24Vdc	1
	30Vdc	2
	48Vac/dc	3
	60-72Vdc	4
	110Vdc/130Vdc; 120Vac	5
	208Vac	6
	220Vdc; 240Vac	7
	250Vdc; 277Vac	8
Second Extended Range Shunt Trip (ANSI/UL) ²	24Vdc	M
	48Vac/dc	P
	70-72Vdc	Q
	110/125Vdc; 120Vac	R
	208Vac	S
	220Vdc; 240Vac	T
Blank/none	250Vdc; 277Vac	V
		X

¹The UVR with Fixed Time Delay is specifically intended for applications where a delay period ('ride-through') is required due to potential voltage events. The design delays are 50msec when system voltage drops to 50% and 20msec when system voltage drops below 50%.

²The Extended Range Shunt Trip is specifically intended and required for UL ANSI Ground Fault applications. The pickup range is 55-110% of the ST coil voltage.

An optional External UVR Time Delay Module is available in a 1 - 3 second delay.

SELECT ONE DEVICE ONLY.

Digit 12 Auxiliary Switch, Coil Signaling Contact

Contact Configuration	Code	
Auxiliary Switch, 3NO+3NC (Power Rated) ³ STANDARD/INCLUDED	2	
Auxiliary Switch, 8NO+8NC (Power Rated) ⁴	4	
Aux. Switch, 3NO/3NC (Power Rated) +2NO/2NC (High Fidelity)	6	
Aux. Switch, 4NO/4NC (Power Rated) +4NO/4NC (High Fidelity) ⁴	8	
Auxiliary Switch, 3NO+3NC (Power Rated)	CSC, PR, (1NO on SD) - Close Coil or CCC	A
	CSC, Hi-Fi via Trip Unit - Close Coil or CCC ⁵	B
	CSC, PR, (1NO on SD) - 1st Shunt Trip	C
	CSC,Hi-Fi via Trip Unit - 1st Shunt Trip ⁵	D
	CSC, PR, (1 NO on SD) - 1st UVR	E
	CSC,Hi-Fi via Trip Unit - 1st UVR ⁵	F
	CSC, PR, (1NO on SD) - 2nd ST or 2nd UVR	G
	CSC, Hi-Fi via Trip Unit - 2nd ST or 2nd UVR ⁵	H
	CSC, PR, (1NO on SD) - Close Coil or CCC	J
	CSC, Hi-Fi via Trip Unit - Close Coil or CCC ⁵	K
Auxiliary Switch, 3NO/3NC (Power Rated)+2NO/2NC (High Fidelity)	CSC, PR, (1NO on SD) - 1st Shunt Trip	L
	CSC,Hi-Fi via Trip Unit - 1st Shunt Trip ⁵	M
	CSC, PR, (1 NO on SD) - 1st UVR	N
	CSC,Hi-Fi via Trip Unit - 1st UVR ⁵	P
	CSC, PR, (1NO on SD) - 2nd ST or 2nd UVR	Q
	CSC, Hi-Fi via Trip Unit - 2nd ST or 2nd UVR ⁵	R
Auxiliary Switch, 3NO+3NC (Power Rated)	CSC, PR, (1NO on SD) - All Installed Devices	S
	CSC,Hi-Fi via Trip Unit - All Installed Devices ⁵	T
Aux. Switch, 3NO/3NC (Power Rated) + 2NO/2N (High Fidelity)	CSC, PR, (1NO on SD) - All Installed Devices	U
	CSC,Hi-Fi via Trip Unit - All Installed Devices ⁵	V

Abbreviations

- CCC = Command Operated Close Coil
- CSC = Coil Signaling Contact
- Hi-Fi = High Fidelity
- PR = Power Rated
- SD = Secondary Disconnect

NOTE: The term "Hi Fidelity" (HiFi) refers to gold-plated contacts used for signal level outputs (10mA minimum - 100mA maximum, 5-30Vdc, 125Vac)

NOTE: If no devices were selected in Digit 8, 9, 10, 11 (Codes = "X"), then Options A - V are Invalid

NOTE: Options A-V are only valid if the corresponding device to be monitored by the Coil Signaling Contact (CSC) is selected in digits 8, 9, 10, 11

³The 3NO/3NC scheme is STANDARD (INCLUDED, CODE 2) and is wired to Secondary Disconnect Block A; all other selections require Secondary Disconnect Block B

⁴For Side-mounted Secondary Disconnect Blocks All options are available EXCEPT options (4 and 8)

⁵In order to output the Coil Signaling status HiFi via trip unit (Options B, D, F, H, K, M, P, R, T, and V) a communications package must be selected in Advanced Features (Digit 19; options "2, 3, 6, 7, 8, 9") This options requires Secondary Disconnect Block B.

If a UL or ANSI Switch is selected in Digit 2 (C, D, M, S), the HiFi via Trip unit Options are not valid (Options B, D, F, H, K, M, P, R, T, and V)

Note: See EntelliGuard™ G Circuit Breaker Configurator for pricing. Contact a sales representative for configurator.



EntelliGuard™ G Circuit Breaker

EntelliGuard™ G Circuit Breaker Nomenclature

Digit 13 Bell Alarm, Mechanical Counter and Trip Annunciation

Bell Alarm, Mechanical Counter and Trip Annunciation	Code
Bell Alarm Contact (1NO/1NC) with Lockout(BACL)	A
Mechanical Operations Counter(MOC)	B
Bell Alarm Contact (1NO/1NC) with Lockout and MOC	C
RTC Power Rated Contacts on SD ¹	1
RTC Signal Rated (Hi-Fi) Contacts on SD ¹	2
RTC Signal Rated(Hi-Fi) Contacts on SD ¹	3
RTC Signal Rated (Hi-Fi) Conacts through Trip Unit ²	D
BACL and RTC Power Rated Contacts on SD ¹	E
BACL and RTC Signal Rated (Hi-Fi) Contacts on SD ¹	F
BACL and RTC Signal Rated (Hi-Fi) through Trip Unit ²	G
BACL,MOC and RTC Power Rated on SD ¹	H
BACL,MOC and RTC Signal Rated (Hi-Fi) through Trip Unit ²	J
MOC and RTC Power Rated on SD ¹	K
MOC and RTC Signal Rated on SD ¹	L
MOC and RTC Signal Rated (Hi-Fi) through Trip Unit ²	M
Blank/none	X

Abbreviations

BACL = Bell Alarm Contact with Lockout

RTC = Ready To Close Contacts

Hi-Fi = High Fidelity

SD = Secondary Disconnect

¹Ready To Close Switches are wired to where a Spring Charge Contact would be

²In order to output the RTC contact output via Trip Unit (options 3, F, J, M) a

communications package must be selected in Advanced Features

(Code 19/Step 16); this requires Secondary Disconnect Block B.

If a UL or ANSI Switch is selected, the (Hi-Fi Through Trip Unit) is not valid

(Options 3, F, J, M).

RTC Through the Trip Unit is not a valid option for Switches. Bell Alarm

Contact with Lockout comes with the Trip Unit set to Manual LO Enabled.

NOTE: The term "Hi-Fi" refers to gold-plated contacts used for signal level

outputs (10mA minimum - 100mA maximum, 5-30Vdc, 125Vac).

Bell Alarm Contact with Lockout comes with the Trip unit set to Manual LO Enabled

Digit 14 Key Interlock and Padlock Provisions

Key Interlock (Breaker Mounted)	Code
Castell Key Interlock	C
Kirk Key Interlock	K
Ronis Key Interlock	R
Pushbutton Padlock Device	L
Castell Key Interlock and Push Button Padlock Device	1
Kirk Key Interlock and Push Button Padlock Device	2
Ronis Key Interlock and Push Button Padlock Device	3
Black/none	X

NOTE: This option provides factory installed interlocking devices for installation between separate circuit breakers (baseplates and mechanism). This safeguard ensures that a circuit breaker cannot be closed unless the dedicated key has been inserted and secured within the lock.

NOTE: If selecting a Draw Out Breaker (Digit 6), consider putting the Key Interlock on the Cassette versus the breaker. This enables the ability to swap breakers without having to change the key interlocks.

Locks and Keys are NOT Supplied by GE.

Digit 15 Mechanical Interlocks

Mechanical Interlocks	Code
Black/None DEFAULT	X
Mechanical Interlock- Type A	1
Mechanical Interlock- Type B	2
Mechanical Interlock- Type C	3
Mechanical Interlock- Type D	4

Some installations use multiple power sources that are required to supply energy simultaneously, alternately, or, in a specified sequence. EntelliGuard™ G Circuit Breakers can be used to interconnect these sources and be electrically and mechanically interlocked to provide the necessary transition and protection. Mechanical Interlocks are available for fixed and draw out circuit breakers. The interlocks enable directly interlocking breakers that are mounted side by side or in vertical stacks. The interlocks consist of two components: (1) The factory-installed bracket fitted to the breaker (fixed breakers) or the cassette (drawout breakers), and (2) The field-installable interconnecting cables available in lengths of 1.0, 1.6, 2.0, 2.5, 3.0, 3.5 and 4.0m (ordered separately). Refer to Section 4 of the Application Guide DET-653B for interlocking schemes.

Contact factory for availability.

Note: See EntelliGuard™ G Circuit Breaker Configurator for pricing. Contact a sales representative for configurator.



EntelliGuard™ G Circuit Breaker

EntelliGuard™ G Circuit Breaker Nomenclature

Digit 16 and 17 Over Current Protection Package

Type	Over Current (OC) Protection Ground Fault	Code
EntelliGuard™ G ANSI/UL OC Protection	LSI (S, switchable) (I, switchable ANSI only)	L3
	LSIG (S, switchable) (I, switchable ANSI only)	L4
	LSIGA (S, switchable) (I, switchable ANSI only) (G, Alarm Only)	L5
	LSIC (S, switchable) (I, switchable ANSI only)	L6
	LSICA (S, switchable) (I, switchable ANSI only) (C, Alarm Only)	L7
	LSIGDA ¹ (S, G, A switchable) (I, switchable ANSI only)	L8
	LSIGCDA ¹ (S, G, C, A all switchable) (I, switchable ANSI only)	L9
	LSH (S, switchable) (I, switchable ANSI only)	LC
	LSHG (S, switchable) (I, switchable ANSI only)	LD
	LSHGA (S, switchable) (I, switchable ANSI only) (G, Alarm Only)	LE
	LSHC (S, switchable) (I, switchable ANSI only)	LF
	LSHCA (S, switchable) (I, switchable ANSI only) (C, Alarm Only)	LG
	LSHGDA ¹ (S, G, A switchable) (I, switchable ANSI only)	LH
	LSHGCDA ¹ (S, G, C, A all switchable) (I, switchable ANSI only)	LK
	NONE - (For Switch Only)	XX

¹Function Combination is NOT UL Listed

NOTES:

L = Long Time (L, I²T) + Fuse Settings (I⁴T) (Fuse settings are now standard on all EntelliGuard™ Trip Units)

S = Short Time (Switchable if Instantaneous (I) protection is enabled)

I = Standard Range Adjustable Instantaneous, (IOC, 2x-15x)

H = Extended Range Adjustable Instantaneous, (IOC, 2x-30x), Not available in UL489 version of Entelliguard G or any Legacy CB

G = Ground Fault Protection (GFP, 3-wire or 4-wire, internal summing)

C = External CT for ground fault detection (AKD20 application: input from external summing CTs, used for multiple source ground fault detection.

OEM Application: Zero Sequence Input of (1A = 100%)

D = Defeatable/Switchable Ground Fault NOT UL Listed

A = Ground Fault, External Ground Fault, Alarm only

GA = Ground Fault Alarm Only

CA = External Ground Fault Alarm Only

GDA, GCDA = Ground Fault Trip and Ground Fault Alarm (all switchable, Not UL Listed)

Option "XX" is the only valid option when a Switch is selected in Digit 2

Digit 18 Zone Selective Interlocking (ZSI)

Zone Selective Interlocking	Code
ZSI, Short time and GF; user selectable	Z
Z+IOC or HSIOC ZSI; user selectable	T
Blank/none	X

ZSI selections require Secondary Disconnect Block B and 24Vdc control power.

NOTE: Option X is the only valid item when a Switch is selected in Digit 2.

Digit 19 Advanced Features and Communications

Advanced Features and Communications	Code
Reduced Energy Let Through (RELT)	1
Modbus Protocol + RELT	2
Profibus Protocol + RELT	3
Monitoring + RELT, NO communication	4
Monitoring + Relay Package + RELT	5
Monitoring+ Data Acquisition, Profibus Protocol + RELT	6
Monitoring+ Data Acquisition, Modbus Protocol + RELT	7
Monitoring + Data Acquisition, Relay Package, Profibus, RELT	8
Monitoring + Data Acquisition, Relay Package, Modbus RELT	9
None	X

NOTES:

—All Advanced Feature selections require Secondary Disconnect Block B and 24Vdc control Power.

—Option "X" is the only valid option when a Switch is selected in Digit 2.

—RELT = Reduced Energy Let Through, requires dedicated input and output on the CB Monitoring = Advanced Metering.

—Data Acquisition = Waveform Capture and Harmonic Analysis.

—In order to output the Coil Signaling status HiFi via trip unit (Digit 12, Options B, D, F, H, K, M, P, R, T, and V) a communications package must be selected in Advanced Features (Digit 19; options 2, 3, 6, 7, 8, 9). This option requires Secondary Disconnect Block B.

—In order to output the RTC contact output via Trip Unit (Digit 13; Options 3, F, J, M) a communications package must be selected in Advanced Features (Code 19/Step 16); this requires Secondary Disconnect Block B.

Digit 20 Rating Plug

Rating Plug	Product Number	Code
150	GTP0150U0104	B
200	GTP0200U0204	C
225	GTP0225U0306	D
250	GTP0250U0407	E
300	GTP0300U0408	F
350	GTP0350U0408	G
400	GTP0400U0410	H
450	GTP0450U0612	I
500	GTP0500U0613	J
600	GTP0600U0616	K
700	GTP0700U0816	M
750	GTP0750U0820	N
800	GTP0800U0820	O
900	GTP0900U1020	P
1000	GTP1000U1025	Q
1100	GTP1100U1225	R
1200	GTP1200U1232	S
1500	GTP1500U1640	U
1600	GTP1600U1640	V
1900	GTP1900U2050	W
2000	GTP2000U2050	Y
2200	GTP2200U2550	Z
2400	GTP2400U2564	1
2500	GTP2500U2564	2
3000	GTP3000U3064	3
3200	GTP3200U3264	4
3600	GTP3600U4064	5
4000	GTP4000U4064	6
5000	GTP5000U5064	7
6000	GTP6000U6064	8
Rating plug not required/non auto switch		X

NOTE: See Section 6 for further details on rating plugs and sensors. Option X is the only valid option when a Switch is selected in Digit 2.

Note: See EntelliGuard™ G Circuit Breaker Configurator for pricing. Contact a sales representative for configurator.



Low Voltage Power & Insulated Case Circuit Breakers Section 8

EntelliGuard™ G Low Voltage Power Circuit Breakers

EntelliGuard™ G Cassettes Nomenclature

The drawout mechanism allows the breaker to be racked in four distinct positions (CONNECTED, TEST, DISCONNECTED, WITHDRAWN). Choice of whether shutters are needed are based in the order option 2nd disconnect Block B (GSDWCR).

EntelliGuard™ G Cassette Product Number Structure

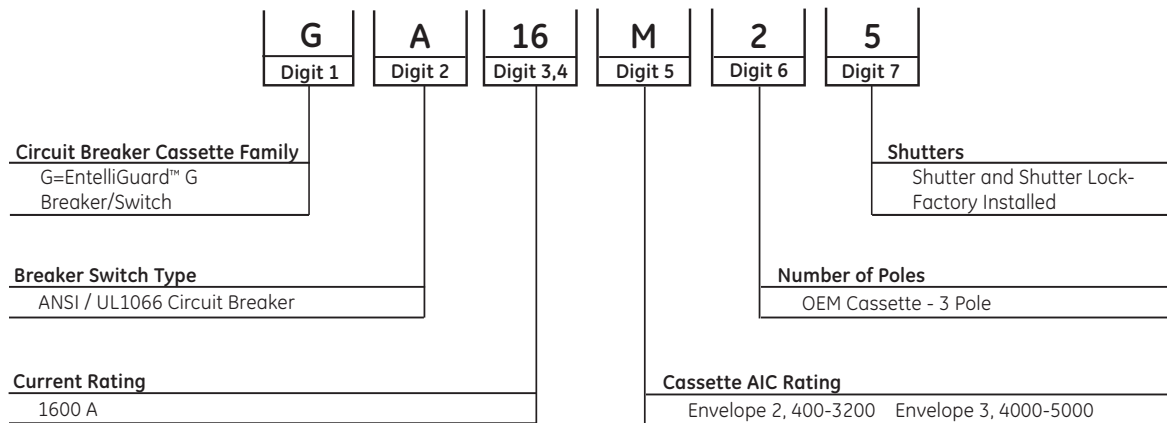

Digit 1 Circuit Breaker Cassette Family

Devices Series/Line	Code
EntelliGuard™ G Breaker/Switch	G

Digit 2 Breaker Switch Type

Cassette Type, Secondary Mounting	Envelope 1		Envelope 2 & 3
	Side	Top	Top
ANSI/UL1066 Circuit Breaker	A	N	A
UL489 Circuit Breaker	B	U	B
ANSI Non-auto CB (ANSI Switch)	C	M	C
UL489 Non-auto CB (UL Switch)	D	S	D

- Top = Top Mounted Secondary Disconnects (TSD).
- Side = Side Mounted Secondary Disconnects (SSD). (Available on Envelope 1 only).
- N, U, M, S characters are for Envelope 1 only with top mounted secondary disconnects (TSD).

—When ordering codes A and B, Side Secondary Disconnects (SSD) are supplied as standard on Envelope 1.

—Codes N and U, are not valid for Envelopes 2 and 3.

—Envelope 1 (Type N and H, Circuit Breaker and Switches, 800A - 2000A).

NOTE: Side Secondary Disconnects are specifically intended for 5-High ("high density") equipment designs

With Side Mounted Disconnects (SSD), EntelliGuard™ Circuit Breakers Auxiliary Switches cannot be 8NO+8NC (Power Rated) or Aux. Switch, 4NO/4NC (Power Rated) + 4NO/4NC (High Fidelity)

Digit 3 and 4 Current Rating

Current Rating (A)	Circuit Breaker	
	ANSI	UL489
800	08	08
1600	16	16
2000	20	20
3000	-	30
3200	32	-
5000	50	-
6000	-	60

NOTE: Select Current Rating equal to or the next higher of the Circuit Breaker or Switch Current Rating



Low Voltage Power & Insulated Case Circuit Breakers Section 8

EntelliGuard™ G Low Voltage Power Circuit Breakers

EntelliGuard™ G Cassettes Nomenclature

Digit 5—Cassette AIC Rating

Interrupting Rating Tier ANSI/UL1066 Devices, LVPCB									Envelope 1		Envelope 2		Envelope 3	
Code	254V	580V	635V	1/2S Withstand	HSIOC	Override No. 1	Override WI	Code	400-1200	400-2000	3200	400-3200	3200	4000-5000
S	65,000	65,000	50,000	50,000	50,000	49,000	53,500	S	X					
N	65,000	65,000	65,000	65,000	None	None	None	N		X	X			
H	85,000	85,000	65,000	65,000	65,000	63,700	69,500	H		X				
P2	100,000	100,000	65,000	65,000	65,000	63,700	69,500	P		X				
E	85,000	85,000	85,000	85,000	None	None	None	E				X		
M	100,000	100,000	100,000	85,000	85,000	83,800	90,950	M				X		X
B	100,000	100,000	100,000	100,000	None	None	None	B					X	X
L	150,000	150,000	100,000	100,000	100,000	98,000	107,000	L					X	X

Interrupting Rating Tier UL489 Devices ICCB									Envelope 1		Envelope 2		Envelope 3	
Code	240V	480V	600V	1/2S Withstand	HSIOC	Override No. 1	Override WI	Code	400-1200	400-2000	2500-3000	400-3000	3000	4000-6000
S	65,000	65,000	50,000	42,000	42,000	N/A	44,940	S	X					
N	65,000	65,000	65,000	42,000	42,000	N/A	44,940	N		X	X			
H	85,000	85,000	65,000	50,000	50,000	N/A	53,500	H		X	X			
M	100,000	100,000	100,000	65,000	65,000	N/A	69,550	M				X		X
L	150,000	150,000	100,000	85,000	85,000	N/A	90,950	L					X	X
P2	100,000	100,000	65,000	50,000	50,000	N/A	50,000	P		X				

ANSI Non-Automatic Switches				30 Cycle Withstand Ratings				Envelope 1		Envelope 2		Envelope 3	
Code	254V	580V	635V					Code	800-2000	800-3000	3000-6000		
N	42,000	42,000	42,000	Note: Non-automatic switches are provided with no internal sensing or tripping mechanism and cannot be applied above their respective withstand levels. If a non-automatic device is required at ratings above the available switches is required, it is recommended that a circuit breaker set with maximum setting be employed using external control or protection as required by the application.				N	X				
M	65,000	65,000	65,000					M		X			
B	100,000	100,000	100,000					B					X
UL489 Non-Automatic Switches								Envelope 1		Envelope 2		Envelope 3	
Code	240V	480V	600V					Code	800-2000	800-3000	3000-6000		
N	42,000	42,000	42,000					N	X				
M	65,000	65,000	65,000					M		X			
B	150,000	150,000	100,000					B					X

Digit 6 Number of Poles

Devices Series/ Line	Code
OEM Cassette - 3 Pole	2
OEM Cassette - 4 Pole	5
GE Equipment Cassette - 3 Pole ¹	7

¹GE Equipment cassette designed specifically for AKD20 Switchgear. These cassettes are NOT available for OEMs.

²P frame available as 3-pole only

Digit 7 Shutters

Shutters with Locks	Code
Shutter and Shutter Lock - Factory Installed	S
None	X

Loose Cassette Parts- Field Installed	Product Number
Carriage Position Switch - 1NO/1NC	GCPS1R
Carriage Position Switch-2NO/2NC	GCPS2R
1 Kirk Key Interlock Cam for Cassette	GCKRKR
1 Ronis Key Interlock Cam for Cassette	GCRONR
Secondary Disconnect Block B, 39 Pole-Top Mounted	GSDWTR
Secondary Disconnect Block B, 39 Pole-Side Mounted	GSDWSR

Secondary Disconnect Block B is required when:

- Any "ZONE SELECTIVE INTERLOCKING" options are selected in breaker/trip unit Catalog Digit 18.
- Any "ADVANCED FEATURES" are selected in breaker/trip unit Catalog Digit 19.
- A COIL SIGNALING CONTACT OPTION is selected, Digit 12.
- A READY TO CLOSE signal via the trip unit is selected, Digit 13.
- Any of the following OPTIONAL Aux. Contact Switches are selected in Digit 12:
 - 8NO/NC POWER RATED
 - 3NO/NC POWER RATED + 2NO/NC Hi-Fi
 - 4NO/NC POWER RATED + 4NO/NC Hi-Fi



Low Voltage Power & Insulated Case Circuit Breakers

EntelliGuard™ G Low Voltage Power Circuit Breakers

Section 8

EntelliGuard™ G Accessories

A wide range of optional accessories are interchangeable across all EntelliGuard G power circuit breakers, regardless of nominal rating or envelope/frame size.

Motorized Spring Charging Unit

The unique motor/gearbox unit is specially designed to operate with the full range of EntelliGuard G breakers. It is easily installed with three heavy-duty bolts. After a breaker close operation, the unit automatically recharges the spring and makes it ready for immediate re-close should the need arise. High speed recharging ensures that the springs are fully charged within approximately three seconds following a release. All electrically operated (EO) ANSI/UL breakers are equipped with "Spring Charged" contacts for status indication.

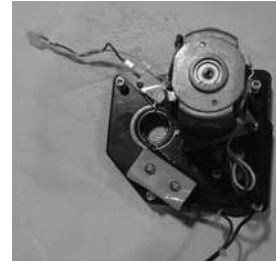

Motorized Spring Charging Unit

Motorized Spring Charging Unit

Envelope	Power Consumption	Nominal Control Voltage	UL and IEC Range (85% to 110%)	ANSI Range	Product Number
1	DC - 300W	24Vdc/30Vdc	20.4V to 26.4V	-	GM01024DR
		48Vdc	40.8V to 52.87V	38V to 56V	GM01048DR
		60Vdc	51V to 66V	-	GM01060DR
		72Vdc	61.2V to 79.2V	-	GM01072DR
		110Vdc/130Vdc	106.25V to 137.5V	100V to 140V	GM01110DR
1	AC - 350VA	250Vdc	212.5V to 275V	200V to 280V	GM01250DR
		48Vac	40.8V to 52.87V	-	GM01048AR
		120Vac	102V to 132V	104V to 127V	GM01120AR
		240Vac	204V to 264V	208V to 254V	GM01240AR
		277Vac	235.5V to 304.7V	-	GM01277AR
2 and 3	DC - 480W	24Vdc/30Vdc	20.4V to 26.4V	-	GM02024DR
		48Vdc	40.8V to 52.87V	38V to 56V	GM02048DR
		60Vdc	51V to 66V	-	GM02060DR
		72Vdc	61.2V to 79.2V	-	GM02060DR
		110Vdc/130Vdc	106.25V to 137.5V	100V to 140V	GM02110DR
2 and 3	AC - 560VA	250Vdc	212.5V to 275V	200V to 280V	GM02250DR
		48Vac	40.8V to 52.87V	-	GM02048AR
		120Vac	102V to 132V	104V to 127V	GM02120AR
		240Vac	204V to 264V	208V to 254V	GM02240AR
		277Vac	235.5V to 304.7V	-	GM02277AR



Circuit Breaker Closing Coils - Standard and Command

Two, easy-to-fit, clip-on closing coil options with simple, plug-in connections are available. Both options offer electrical remote release of the spring charged closing mechanism. Both options include a standard anti-pump safety feature ensuring that the close signal must be released before further close commands are allowed. The Command Close Coil additionally provides for local breaker close and remote breaker close over communications via the EntelliGuard Trip Unit.



Close Coil

Command Operation Module

This module energizes the closing coil to cause the breaker to close whenever control power is applied to the accessory and when commanded from the breaker trip unit or breaker front panel push button (electrical closing.)

Closing Coil / Command Operation Module

Type	Power Consumption	Nominal Control Voltage	Product Number
Closing Coil (CC)	DC: 350W, 20 W (sealed)	24Vdc	GCCN024DR
		48Vac/dc	GCCN048R
		60 to 72Vdc	GCCN060DR
		110/130/120Vac	GCCN120R
		208Vac	GCCN208AR
Command Closing Coil (CCC)	AC: 350W (inrush), 20W (sealed)	220Vdc/240Vac	GCCN240R
		250Vdc/277Vac	GCCN277R
		24Vdc	GCCC024DR
		48Vac/dc	GCCC048R
		60 to 72Vdc	GCCC060DR
		110/130/120Vac	GCCC120R
		208Vac	GCCC208AR

Shunt Trip for Ground Fault

Energizing the shunt trip (ST), via local or remote input, will instantaneously activate the circuit breaker mechanism, ensuring a rapid open operation. The shunt trip is continuously rated and does not require an auxiliary switch in series with the coil. The shunt trip is a straightforward, field installable accessory available in wide range of voltages.



Shunt Trip

Normal Control Voltage	Product Number
24Vdc	GSTG024DR
48Vac/dc	GSTG048R
70/72Vac	GSTG072DR
125Vdc	GSTG125DR
110Vdc/120Vac	GSTG120R
208Vac	GSTG208AR
240Vac	GSTG240R
250Vdc/277Vac	GSTG250DR



Low Voltage Power & Insulated Case Circuit Breakers

EntelliGuard™ G Low Voltage Power Circuit Breakers

EntelliGuard™ G Accessories

Status Indication Switch (Coil Signaling Contact)

A plug-in module is available to provide status indication via the secondary disconnects and trip unit. Coil Signaling Contacts are available for closing coils, shunt trips and under voltage releases. Contact is mounted on top of the Accessory Device. One of the low signal (Hi-Fi) contacts is always wired to the trip unit.



Status Indication Switch

Type and Configuration	Rating	Voltage	Amps	Product Number
	AC	120Vac	6	
1 Power rated +	AC	250Vac	6	
1 Low signal (Hi-Fi)	DC	120Vac	0.5	GCSP1R
(1NO contact each)	DC	250Vac	0.25	
	AC	125Vac	0.1	
	DC	30Vdc	0.1	
2 Low signal (Hi-Fi)	AC	125Vac	0.1	GCSP2R
(1NO contact each)				



Status Indication Switch

Under Voltage Release (UVR) with Fixed Time Delay

The UVR instantaneously activates the circuit breaker trip mechanism when the source voltage drops below the low voltage threshold. The UVR is also a simple, field installable device.



Under Voltage Release

Power Consumption	Nominal Control Voltage	Product Number
	24Vdc	GUVT024DR
DC: 350W,	30Vdc	GUVT030DR
2W (sealed)	40Vdc; 48Vac/dc	GUVT048R
	60 - 72Vdc	GUVT060DR
	110Vdc/130Vdc; 120Vac	GUVT120R
AC: 350W	208Vac	GUVT208AR
(inrush),	220Vdc; 240Vac	GUVT240R
20W (sealed)	250Vdc; 277Vac	GUVT277R

Duty Cycle = 2/min.
 Inrush = 350VA (AC), 350W (DC)
 Holding = 60VA (AC), 50W (DC)



Time Delay Module (TDM) for UVR (Externally Mounted)

The de-energized operation of the Undervoltage release can be delayed. This optional, externally mounted module has an adjustable time delay of 0 seconds to 3 seconds. The device can be implemented to prevent undesired breaker tripping due to momentary voltage interruptions and is connected in series with the Undervoltage release. The time delay is in addition to the time delay from the breaker mounted UVR accessory. The time delay module starts counting at 50% of rated voltage.



Time Delay Module

Nominal Control Voltage	Product Number
48Vdc	GTDM048D
48Vac	GTDM048A
60Vdc	GTDM060D
125Vdc	GTDM120D
120Vac	GTDM120A
208Vac	GTDM208A
240Vdc	GTDM240D
240Vac	GTDM240A
250Vdc	GTDM250D
277Vac	GTDM277A

Ready To Close Contact

These contacts indicate that the following conditions are met and the circuit breaker can be closed:

- The circuit breaker is open.
- The closing springs are charged.
- The circuit breaker is not locked/interlocked in open position.
- There is no standing closing signal.
- There is no standing opening signal.

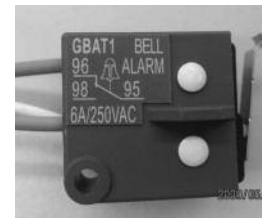

Ready To Close Contact

1 NO

	Voltage	Amps	Description	Product Number
AC	120Vac	6	High fidelity/secondary disconnect	GRTC2R
	250Vac	6	-	
DC	125Vdc	0.5	Power rated/secondary disconnect	GRTC1R
	250Vdc	0.25	High fidelity/trip unit	GRTC3R

Auxiliary Switches

Auxiliary switches indicate breaker main contact position. They change their state in the same time sequence as the breaker main contacts.



Contact Configuration	Power Rated	Hi-Fi	Product Number
Power rated (3NO, 3NC)	A14 - A25	N/A	GAUX3R
Power rated (3NO, 3NC); low signal (Hi-Fi), (2NO, 2NC)	A14 - A25	B10 - B13, B23 - B26	GAUX5R
Power rated (8NO, 8NC)	A14 - A25, B4 - B13, B17 - B26	N/A	GAUX6R
Power rated (4NO, 4NC); low signal (Hi-Fi), (4NO, 4NC)	A14 - A25, B12 - B13, B25 - B26	B4 - B11, B17 - B24	GAUX8R



Circuit Breaker - Key Interlock Facility

This option supplies factory-installed key interlock mounting provisions (baseplates and mechanism) on the front of the breaker fascia. Key interlocks ensure that a circuit breaker cannot be closed unless the dedicated key has been inserted and secured within the lock. Circuit breakers accept ready-to-fit interlocking device kits such as Castell, Ronis, Kirk and Profalux for installation between related, separate circuit breakers.

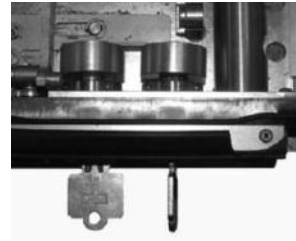

Key Interlock Facility

Description	Product Number
Baseplate and mechanism for Kirk Key Locks (Breaker Mounted)	GBKRKR
Baseplate and mechanism for Ronis Locks (Breaker Mounted)	GBRONR
Mechanism for Ronis Key cassette interlock (Cassette mounted)	GCRONR
Mechanism for Kirk Key cassette interlock (Cassette mounted)	GCKRKR

Carriage Position Switch (TOC)

Available as an option for mounting within the base of the cassette/substructure, the carriage position switch provides six single-pole changeover contacts (single pole, double throw) for local or remote electrical indication of the circuit breaker status: CONNECTED, TEST and DISCONNECTED. The DISCONNECTED position is indicated only when minimum isolating distances between contacts on both the main and auxiliary circuits have been achieved. This option is in addition to the mechanical indicators, which are fitted as standard. When installed, the carriage switch is IP2X protected.



Carriage Position Switch (TOC)

Switch Configuration	Product Number
1 NO/NC switch per position	GCPS1R
Set of 2 NO/NC switches per position	GCPS2R
Set of 6 NO/NC switches connected position	GCPS3R



Mechanical Interlocks (Cable/Rod) (OEM Applications Only)

Available for fixed and draw-out circuit breakers, these units enable the direct interlocking of EntelliGuard G circuit breakers, either mounted side-by-side or stacked. The interlocking mechanisms are connected by a specially designed cable or rod in a 1 from 2, 1 from 3, and 2 from 3 configuration, and any mix of current ratings/pole configurations can be accommodated.

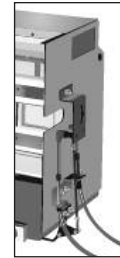

Interlock Type	Number of Cables Required	Breaker Type	Poles	Product Number
2 Way - Type A	2	Withdrawable	3	GI2WADR
		Withdrawable	4	GI3WADR
		Fixed	3	GI2FADR
		Fixed	4	GI3FADR
1 from 2 - Type B	6	Withdrawable	3	GI2WBR
		Withdrawable	4	GI3WBR
		Fixed	3	GI2FBR
2 from 3 - Type C	6	Fixed	4	GI3FBR
		Withdrawable	3	GI2WCR
		Withdrawable	4	GI3WCR
1 from 3 - Type D	4	Fixed	3	GI2FCR
		Fixed	4	GI3FCR
		Withdrawable	3	GI2WDTR
		Withdrawable	4	GI3WDTR
		Fixed	3	GI2FDTR

Refer to Section 4 of the Application Guide DET-653B for interlocking schemes.

Mechanical Interlock Cables

Standard cable lengths are shown. (Cables ordered separately. Please contact our technical customer service department if longer length is required.)

Length (M/In)	Product Number
1 / 39.4	GCB1
1.6 / 63	GCB2
2 / 78.7	GCB3
2.5 / 98.4	GCB4
3 / 118/1	GCB5
3.5 / 137.8	GCB6
4 / 157.5	GCB7

Bell Alarm with Lockout

The Bell Alarm provides remote indication that the circuit breaker has opened because of an electrical fault. The Lockout feature is integral to the trip unit. When a Bell Alarm is supplied with the breaker, the Trip Unit dial is set and locked to the manual position. In order to re-close the breaker, the Lockout button must be pushed in/reset on the Trip Unit 1-Form C contact.



Bell Alarm with Lockout

Switch Configuration	Product Number
Single pole, double throw (1-Form C contact)	GBAT1R



Charging Spring Status Indicator

Factory-installed on the motor, this auxiliary switch indicates that the circuit breaker is charged and is standard with the spring-charging motor.

Voltage	Ratings		Product Number
	Amps		
120Vac	6		GSCC1R
250Vac	6		
125Vdc	0.5		
250Vdc	0.25		



Charging Spring Status Indicator

Neutral Rogowski

The Neutral Rogowski CT's are used to measure the Neutral Current and is required when Internal Ground Fault is selected on the trip unit. There are two types available: Encased with Terminal Screws: The Rogowski coil is encased with two terminal screws. No additional mounting hardware is required as the encasing is molded to the mounting dimensions.

Loose Rogowski Coil with separate mounting hardware: The coil and mounting hardware are separate. The coil comes with the two wire leads for connection to a terminal block.

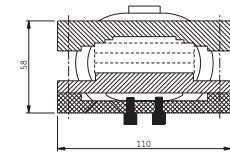
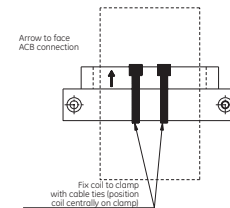

Remark: for ratings > 4000A two coils are used

Neutral Rogowski External

Type	Envelope	Current Rating (A)	Product Number
Encased with Terminal Screws	1	400	G04HNRCE
		600/630	G07HNRCE
		800	G08HNRCE
		1000	G10HNRCE
		1200/1250	G13HNRCE
		1600	G16HNRCE
		2000	G20HNRCE
	2	400	G04MNRCE
		600/630	G07MNRCE
		800	G08MNRCE
		1000	G10MNRCE
		1200/1250	G13MNRCE
		1600	G16MNRCE
		2000	G20MNRCE
Loose Rogowski Coil and Mounting Hardware	1	2500	G25MNRCE
		3000/3200	G32MNRCE
		3000/3200 (1600 x 2)	G32LNRC
	2	4000 (2000 x 2)	G40LNRC
		5000 (2500 x 2)	G50LNRC
		6000/6400 (3200 x 2)	G64LNRC
Loose Rogowski Coil and Mounting Hardware	1	400	G04HNRC
		600/630	G07HNRC
		800	G08HNRC
		1000	G10HNRC
		1200/1250	G13HNRC
		1600	G16HNRC
		2000	G20HNRC
	2	400	G04MNRC
		600/630	G07MNRC
		800	G08MNRC
		1000	G10MNRC
		1200/1250	G13MNRC
		1600	G16MNRC
		2000	G20MNRC
Loose Rogowski Coil and Mounting Hardware	2	2500	G25MNRC
		3000/3200	G32MNRC
		3000/3200 (1600 x 2)	G32LNRC
	3	4000 (2000 x 2)	G40LNRC
		5000 (2500 x 2)	G50LNRC
		6000/6400 (3200 x 2)	G64LNRC



Door Escutcheon Kit for IP54 Protection

An optional complete IP54 front door panel is available when a higher degree of protection is needed.

Description	Product Number
Door Escutcheon Kit - IP54 Door Panel - Fixed/ Drawout	G54DR



IP54 Door Escutcheon

Mechanical Operations Counter

Used with either manual or motor charged circuit breakers, the counter provides an accurate record of the cumulative number of complete breaker closing operations.

Description	Product Number
Mechanical Operations Counter	GMCNR

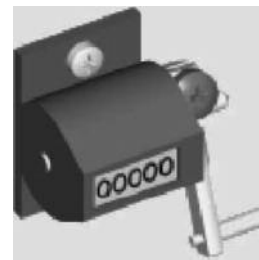

Mechanical Operations Counter

Door Interlock Kit

A door interlock mechanism may be fitted inside the cassette on the right for Left hinged door or Left for Right hinged door. Specify whether door is Left hand or Right hand hinged when ordering. Door interlock is different for a cassette with side mounted secondary disconnect.

Description	Product Number
Door Interlock (Left Side)	GLHD
Door Interlock (Right Side)	GRHD



Door Interlock Kit

Front Flat Terminations

The EntelliGuard G Fixed mounted breaker comes standard with Back Connected Terminations. Optional Front Flat terminations are available for front access mounting.

Description	Product Number
Env1 800 - 2000A, Type N&H, Flat Front UL489, Fixed 3 Pole Breaker Bus Bar Terminations (Top/Bottom)	GBB1TBF3
Env1 800 - 2000A, Type N&H, Flat Front UL489, Fixed 4 Pole Breaker Bus Bar Terminations (Top/Bottom)	GBB1TBF4
Env2 800A - 3000A Flat Front UL489 Fixed 3 Pole Breaker Bus Bar Terminations (Top/Bottom)	GBB2TBF3
Env2 800A - 3000A Flat Front UL489 Fixed 4 Pole Breaker Bus Bar Terminations (Top/Bottom)	GBB2TBF4
Env3 4000-6000A Flat Front UL Fixed 3 Pole Breaker Bus Bar Terminations (Top/Bottom)	GBB3TBF3
Env3 4000-6000A Flat Front UL Fixed 4 Pole Breaker Bus Bar Terminations (Top/Bottom)	GBB3TBF4

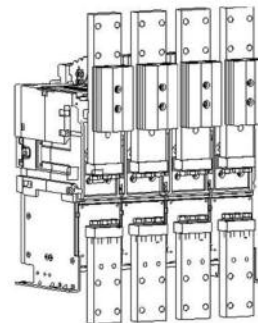

Front Flat Terminations



Low Voltage Power & Insulated Case Circuit Breakers

EntelliGuard™ G Low Voltage Power Circuit Breakers

EntelliGuard™ G Accessories

Arcing Contacts Assembly

Arcing contacts are supplied with the EntelliGuard breaker.

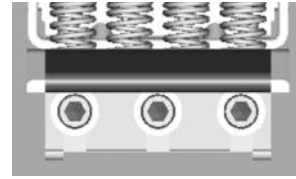

Description	Product Number
Ent. Grd 1p EG1 H Type	G20HARC
Ent. Grd 1p EG1 S&N type	G20NARC
Ent. Grd 1p EG2 H&M type	G40MARC
Ent. Grd 1p EG2 E&N type	G40NARC
Ent. Grd 1p EG33200-6400A	G64LARC

Contact Wear Indicator

The contact wear indicator is a simple device that allows the user to establish if the main contacts need replacement. It can be used on devices of the fixed pattern (if the arc chutes can be removed) and on devices of the draw out pattern.



Description	Product Number
Contact Wear Indicator	GCNTW

Racking Handle

A collapsible Racking Handle is provided to rack in/out the draw out breakers whenever needed.



Description	Product Number
Racking Handle	GRHNR

Back Connected Terminations Fixed Envelope

Terminal assemblies are supplied with the EntelliGuard breaker. Fixed breakers have back or front connected terminations available.

Envelope Size	Description	Type	Product Number
1	Up to 1600A	3 Pole	GBB116TBB3
		4 Pole	GBB116TBB4
	200A	3 Pole	GBB120TBB3
		4 Pole	GBB120TBB4
2	Up to 2000A	3 Pole	GBB220TBB3
		4 Pole	GBB220TBB4
	3000A UL	3 Pole	GBB230TBB3
		4 Pole	GBB230TBB4
	3200A ANSI	3 Pole (Top Side)	GBB232TBB3
		3 Pole (Bottom Side)	GBB232BBB3
		4 Pole (Top Side)	GBB232TBB4
		4 Pole (Bottom Side)	GBB232BBB4
3	up to 4000A	3 Pole	GBB340TBB3
		4 Pole	GBB340TBB4
	6000A	3 Pole (Top Side)	GBB360TBB3
		3 Pole (Bottom Side)	GBB360BBB3
		4 Pole (Top Side)	GBB360TBB4
		4 Pole (Bottom Side)	GBB360BBB4



Low Voltage Power & Insulated Case Circuit Breakers Section 8

EntelliGuard™ G Low Voltage Power Circuit Breakers

EntelliGuard™ G Accessories

Back Connected Terminations For Cassette

Envelope Size	Description	Type	Product Number
1	Up to 1600A	3 Pole	GBB216TBBC3
		4 Pole	GBB216TBBC4
	200A	3 Pole	GBB220TBBC3
		4 Pole	GBB220TBBC4
2	Up to 1600A	3 Pole	GBB216TBBC3
		4 Pole	GBB216TBBC4
	Up to 2000A	3 Pole	GBB220TBBC3
		4 Pole	GBB220TBBC4
3	3000A UL	3 Pole	GBB230TBBC3
		4 Pole	GBB230TBBC4
	3200A ANSI	3 Pole (Top Side)	GBB232TBC3
		3 Pole (Bottom Side)	GBB232BBC3
4 Pole (Top Side)		GBB232TBC4	
4 Pole (Bottom Side)		GBB232BBC4	
3	6000A	3 Pole (Top Side)	GBB360TBC3
		3 Pole (Bottom Side)	GBB360BBC3
		4 Pole (Top Side)	GBB360TBC4
		4 Pole (Bottom Side)	GBB360BBC4

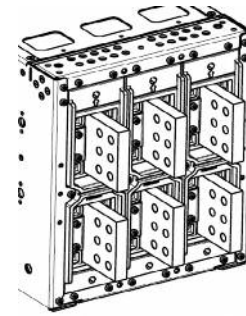

Envelope 1 and 2, 3 Pole
1600A

Cluster Pad

Envelope Size	Description	Product Number
1	Cluster Pad (set per phase) Qty 2 per	GBB120TBD
2	Cluster Pad (single cluster) 2000A Qty 2 per	GBB220TBD
	Cluster Pad (double cluster) 2500A - 3200A Qty 2 per	GBB232TBD
3	Cluster Pad Qty 2 per	GBB360TBD



Envelope 2, Cluster Pad
(Single Cluster) 2000A

Cluster

Envelope Size	Description	Product Number
1	36 finger (95x20 mm) Qty 1	G20NCLS
2	36 finger (95x20 mm) Qty 1	G20MCLS
3	36 finger (95x15 mm) Qty 1	G32ECLS
	36 finger (95x15 mm) Qty 1	G64LCLS

Fixed Secondary Disconnect (Breaker Mounted)

Fixed breakers are always supplied with a secondary disconnect (auxiliary connection block) suitable for 39 connection points (terminal A). When the number of factory installed accessories exceeds the available number of connection points needed, a 2nd connection block is automatically added (terminal B). For cases where the accessories are mounted in the field, an additional auxiliary connection block can be added to provide 39 more connections.



Description	Product Number
Fixed Breaker Top Mounted Secondary Disconnect, 39 Pole Male/Female	GSDFTR1
Fixed Breaker Top Mounted Secondary Disconnect, 78 Pole Male/Female	GSDFTR2
Fixed Breaker Side Mounted Secondary Disconnect, 78 Pole Male/Female	GSDFSR



Low Voltage Power & Insulated Case Circuit Breakers

EntelliGuard™ G Low Voltage Power Circuit Breakers

EntelliGuard™ G Accessories

Network Interlock Device (NI)

The Network Interlock Device locks the breaker in the OFF position electrically and mechanically. When this device receives a pulse all local breaker functionality is disabled, except the tripping of the device on any over current fault. On the receipt of a 2nd pulse normal operation is re-instated. The presence of mains power does not affect the locking and/or re-instatement of this device. Each device has a local RESET button that only can be accessed after breaker cover removal.



Description	Product Number
Network Interlock 120V, UL Listed	GNTK120R

Remote Racker

The Remote Racking Operator allows the user to move a draw out circuit breaker between the CONNECT and DISCONNECT positions via an electric racking gear head motor and the cassette housing the breaker. The remote racking operator requires 115Vac, 60Hz control power. A control box connected to the operator with a thirty-foot cord permits control from a remote location.



Description	Product Number
Remote Racker	EGGRRLV

Lifting Devices

Poles	Frame	Product Number
3	1 and 2	GLD3F12
3	3	GLD3F3
4	1 and 2	GLD4F12
4	3	GLD4F3
ACB Lifting Truck		ACBLIFT

For more accessories and options, see the EntelliGuard™ G Application Guide DET-653B.

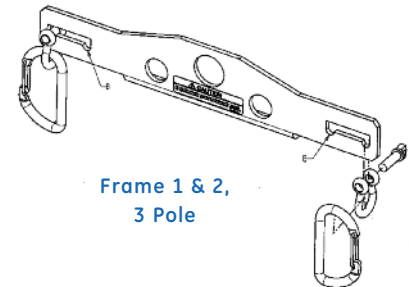

Frame 1 & 2,
3 Pole

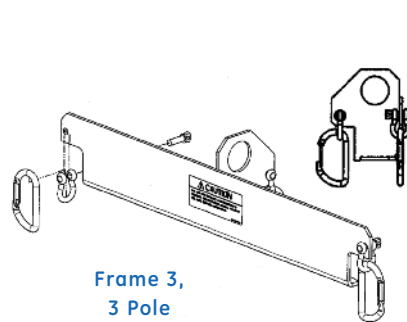

Frame 3,
3 Pole

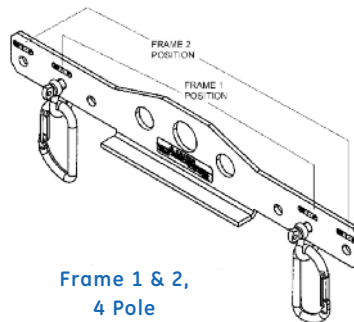

Frame 1 & 2,
4 Pole

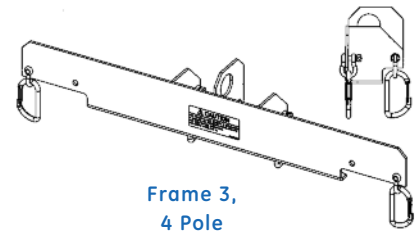

Frame 3,
4 Pole



Low Voltage Power & Insulated Case Circuit Breakers Section 8

WavePro Circuit Breakers with EntelliGuard™ TU, Power+, Enhanced MicroVersaTrip™ Plus and MicroVersaTrip™ PM Trip Unit Systems



There are four trip unit systems available for WavePro Low Voltage Power Circuit Breakers — EntelliGuard™ TU, Power+, Enhanced MicroVersaTrip™ Plus and MicroVersaTrip™ PM. All four systems consist of the trip unit, the trip actuator, current sensors and rating plugs. The term “trip unit systems” applies to the combination of these four components, which form the circuit breaker solid-state tripping system.

The EntelliGuard™ TU Trip Unit is the latest addition to the list of trip units available on GE low voltage power circuit breakers. The new functions offered by the trip unit enhance the WavePro breaker with Waveform Recognition Instantaneous which improves coordination with current limiting devices and reduces nuisance trips by discerning whether a downstream breaker/fuse is clearing the fault. The unit also provides optimum circuit safety and arc flash protection with the Reduced Energy Let Through, providing a faster instantaneous trip that may be used in case faster and more sensitive protection is temporarily required. Its Zone Selective Interlocking provides the ability to overlap the Instantaneous on the Main and Feeder breakers and the EntelliGuard™ TU also has Flexible Time Current Curves: 44 Long Time Shapes (I^2T and I^4T (fuse)), 3 Short Time I^2T slopes, Short Time adjustable in 55 msec increments and a Selective Ground Fault curve.

All of the new functions and features in the new EntelliGuard™ TU trip unit provide ultimate system reliability and selectivity without sacrificing circuit protection.

Designed for Flexibility

- A wide range of continuous adjustment Long Time delays ensure the circuit breaker can be exactly dialed in to your selectivity and protection needs.
- Multiple Short Time diagonal bands tune your protection to exactly where it needs to be.
- Flexible time current settings and curves — Standard Long Time characteristics exactly mimic the curve of a thermal magnetic circuit breaker.
- Flexible Time Current Curves: 44 Long Time Shapes (I^2T and I^4T (fuse)), 3 Short Time I^2T slopes, Short Time adjustable in 55 msec increments, a Selective Ground Fault curve

Instantaneous Protection

- Instantaneous pick up is adjustable up to 15 times plug rating on every circuit breaker and, optionally, up to 30 times on some breakers.
- A separately adjustable fast instantaneous trip — useful for when the circuit must provide the best possible protection and arc flash performance while sustaining normal load
- An override instantaneous provides fast tripping for the largest bolted fault currents to minimize potential damage.
- Up to 17 Short Time bands allow you to set your circuit breaker to sustain load requirements without slowing protection.
- Ground Fault Alarm via I/O, or
- Ground fault protection with faster time bands, multiple slopes and the ability to coordinate a 1200A ground fault with an 800A circuit breaker — a ratio four times better than in previous generation trip units

Maintenance and Diagnostics

- Universal spare trip unit that will fit any GE circuit breaker
- Universal trip plug fits any trip unit
- Flexible serial communication via Modbus RTU
- Integrates directly into GE's EnerVista™ Power Management System
- Health status via breaker LED indicating normal operation, errors, pickup, and trips while providing non-volatile memory with a continuous self-testing microprocessor
- Lithium battery to eliminate need for external power
- 10 event Log with Date/Time Stamp: Stores the last 10 events. Date/Time with 24VDC Power.
- Thermal Memory
- WaveForm Capture: 40 Samples/Cycle, 4 cycles prior and 4 cycles post event in COMTrade format
- Large backlit LCD with detailed, easy to see descriptions



Low Voltage Power & Insulated Case Circuit Breakers Section 8

WavePro Circuit Breakers with EntelliGuard™ TU, Power+, Enhanced MicroVersaTrip™ Plus and MicroVersaTrip™ PM Trip Unit Systems

The Power+ trip unit continues to use GE's proven technique of measuring true rms currents of both sinusoidal and harmonically distorted waveforms. The frequent sampling (48 times per cycle per phase) allows precise calculations of true rms current. The sampling rate allows waveform measurements up to the 11th harmonic. True rms sensing avoids potential under- or over-protection problems associated with peak-sensing tripping systems.

The Power+ trip unit is identified by its plug-in modules and rotary switches. The optional "target module" provides LED targets for overload, short circuit and ground fault trips. View and Reset push buttons are also provided to monitor status, including a battery check LED. Standard 3-volt lithium batteries in the target module power the indicating LEDs (batteries are not required for trip unit operation). The "rating plug module" serves the dual purpose of establishing the trip rating for the circuit breaker as well as providing ground fault protection when required. All pickup and delay settings are selected with detented rotary switches.

Standard Functions:

—Rating plug with test port

Protection

—Long-time, Instantaneous (Instantaneous may be omitted when short-time is provided)

Optional Functions:

Protection

—Short-time protection, with selectable I^2t
—Ground fault protection, with selectable I^2t
—Defeatable ground fault (not UL)

Target Module

—View and Reset buttons
—Battery check LED
—Longtime pickup/trip unit "health" LED
—LEDs for overload, short circuit, ground fault trips

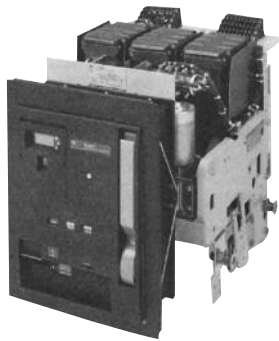

Enhanced MicroVersaTrip™ Plus and MicroVersaTrip™ PM trip units also measure true rms currents (and voltages for MicroVersaTrip™ PM trip units). The higher sampling rate (64 times per cycle) allows waveform measurements up to the 31st harmonic to achieve accuracy of 99%.

MicroVersaTrip™ Plus and MicroVersaTrip™ PM trip units contain a digital liquid crystal

display with a five-button keypad for local setup and readout of trip settings. The trip units have a lithium battery for cold setup capability and viewing of targets without external power. The LCD and keypad also provide a three-phase ammeter and trip indicators.

The Enhanced MicroVersaTrip™ (MVT) PM trip unit adds power management system capability, including advanced metering and protective relaying, to the basic functions of the MVT Plus. The MVT PM can be interfaced with either Modbus RTU or Ethernet TCP/IP compatible systems.

All trip units utilize a series of interchangeable rating plugs to establish the current rating of the breaker.

Standard Functions:

—Rating plug with test port

Protection

—Long-time, Instantaneous (Instantaneous may be omitted when short-time is provided)

Status

—Trip target (trip type)
—Trip information (magnitude and phase)
—Trip operations counters

Metering Display

—Phase current (selectable among phases)

Optional Functions:

—Short-time protection, with selectable I^2t
—Ground fault protection, with selectable I^2t
—Defeatable ground fault (not UL)
—Switchable instantaneous/short-time and ground fault (not UL).
—Zone-selective interlock, for ground fault only or for both ground fault and short-time protection.

Additional Functions available only with MicroVersaTrip™ PM trip unit:

—Communication and metering (M-option)
—Communication, metering and protective relaying (PM-option)

Communication:

—Remote communication with POWER LEADER™ Power Management Control System (PMCS) software

Metering:

—Voltage (V), Energy (kWh/MWh/GWh)
—Real Power (kW/MW), Total Power (kVA/MVA)
—Demand Power (kW/MW), Peak demand power (kW/MW)
—Frequency (Hz)

Protective Relaying:

—Undervoltage, Overvoltage
—Voltage unbalance, Current unbalance, Power reversal



Low Voltage Power & Insulated Case Circuit Breakers Section 8

WavePro Low Voltage Power Circuit Breakers

How to select WavePro low voltage power circuit breakers – One step at a time

This selection guide allows you to systematically arrive at the product number for a WavePro OEM breaker. It also contains information you can use to specify applicable fuses, neutral current transformers and other associated devices (Tables A-1 to A-4 on pages 8-30 and 8-31 and Tables B-5 to B-12 on pages 8-44 and 8-45) and to select and order substructures and substructure accessories (Tables B-1 to B-4 on pages 8-40 to 8-44). The WavePro Breaker Application Guide (DET-167) contains additional information that will help you select options to specify for your particular application.

First, determine the appropriate WavePro breaker type from Table A-1 on page 8-30.

Using that information, follow the step-by-step instructions beginning on page 8-33 to select options and accessories. At the end of each step, transfer the resulting product number digit(s) for your selection to the appropriate boxes in the Product Number Line. **Helpful Hint:** Make a photocopy of the Product Number Line (page 8-29) every time you follow this process so you can use the form again.

When you're done, you'll have a complete breaker product number. Note: To order, you must submit a complete 15-digit breaker product number. If you reach a point where no further options or accessories are required, fill in each of the remaining product numbers digits with X (indicating no option or accessory) before

submitting your order. Here's an example of the selection based on a WavePro breaker with the following specifications: digits with X indicate no option or accessory. Example is on pages 8-26 through 8-28. **Breaker selection starts on page 8-33.** An alternative to developing the breaker product number and pricing manually is to generate the same information electronically via the web wizards at www.geindustrial.com/industrialsystems/wizards/peb_oem_am/home.htm

Rated AC Voltage Nominal (Max.)	Breaker Type	Frame Size (amps)	Short Circuit Ratings RMS Symmetrical		
			kA		
			Short-Time Withstand	With Instantaneous Trip	Without Instantaneous Trip
480 (508)	WPS-08	800	30	30	30
	WPH-08	800	42	42	42
	WPX-08	800	65	65	65
	WPS-16	1600	50	50	50
	WPH-16	1600	65	65	65
	WPS-20	2000	65	65	65
	WPS-32	3200	65	65	65
	WPH-32	3200	85	85	85
	WPX-32	3200	100	100	100
	WPS-40	4000	85	85	85
	WPX-40	4000	100	100	100
	WPS-50	5000	85	85	85
	WPX-50	5000	100	100	100

Note: See WavePro configurator for pricing. Contact a sales representative for configurator.

Example

Option or Accessory	Option or Accessory
Tables A-1 to A-4	WPF-08 Breaker, 800A Frame
Step 1	800A Class L Fuse, 800A Sensor
Step 2	MVT PM Trip Unit with LSIg functions
Step 3	700A Trip Unit Rating Plug
Step 4	120V ac 60Hz Electrical Charge & Close Operation
Step 5	120V ac shunt trip, 60 Hz
Step 6	240V, 50/60 Hz electric lockout
Step 7	4-stage aux switch
Step 8	Bell alarm with lockout
Step 9	24V dc shunt trip (second shunt trip)
Step 10	Hidden close push button and remote charge indicator (Note: "A" disconnect comes standard with the options selected here.)

Product Number Line – WavePro Breaker (Example)

WavePro Breaker for Substructures		Step 1	Step 2	Step 3	Step 4	Step 5	Step 6	Step 7	Step 8	Step 9	Step 10	Future use but "X" required
W	S	G D	C Q	E	F	1	5	A	B	B	E	X

Step 1 Select Interrupting Type and Current Sensor (Example)

GO TO STEP 2 ON PAGE 8-27

Breaker Type	Interrupting Type & Rating	Current Sensor				
		No Sensor ¹	150A	400A	800A	
WPS-08	Standard	—	1A	1B	1C	1D
WPH-08	High	—	2A	2B	2C	2D
WPX-08	Extended	—	3A	3B	3C	3D
WPF-08	Class J Fuse	300A Fuse	—	AB	AC	AD
		350A Fuse	—	BB	BC	BD
		400A Fuse	—	CB	CC	CD
		450A Fuse	—	DB	DC	DD
		500A Fuse	—	EB	EC	ED
		600A Fuse	—	FB	FC	FD
	Class L Fuse	800A Fuse	—	GB	GC	GD
		1000A Fuse	—	HB	HC	HD
		1200A Fuse	—	JB	JC	JD
		1600A Fuse	—	KB	KC	KD



Low Voltage Power & Insulated Case Circuit Breakers Section 8

WavePro Low Voltage Power Circuit Breakers

Step 2 Select Trip Unit (Example)

Function Code	Functions								EntelliGuard™ Trip Unit	MicroVersaTrip™ Plus	MicroVersaTrip™ M	MicroVersaTrip™ PM
	Long Time	Short Time	Instantaneous	Ground Fault ¹	Defeatable Ground Fault ¹	Switchable S T or Inst & GF ¹	ZSI-G F	ZSI-GF & ST	Product No. Digits	Product No. Digits	Product No. Digits	Product No. Digits
LI	•		•						GA	AJ	BJ	CJ
LIG	•		•	•					GB	AK	BK	CK
LIGZ1	•		•	•			•		GC	AL	BL	CL
LIGD ²	•		•	•	•				GD	AM	BM	CM
LIGDZ1 ²	•		•	•	•		•		GE	AN	BN	CN
LS	•	•							GF	AA	BA	CA
LS G	•	•		•					GH	AB	BF	CC
LSGZ1	•	•		•			•		GK	AA	BA	CA
LSGZ2	•	•		•				•	GL	AD	BD	CD
LSGD ²	•	•		•	•				GM	AE	BE	CE
LSGDZ1 ²	•	•		•	•		•		GN	AF	BF	CF
LSGDZ2 ²	•	•		•	•			•	GP	AG	BG	CG
LSI	•	•	•						GQ	AP	BP	CP
LSIG	•	•	•	•					GR	AQ	BQ	CQ
LSIGX	•	•	•	•		•			GS	AR	BR	CR
LSIGZ1	•	•	•	•			•		GT	AS	BS	CS

Step 3 Select Trip Unit Rating Plug By Current Sensor (Example)

Example only - ordering information starts on page 8-33.

Product No.	EntelliGuard™ TU Trip Unit	MicroVersaTrip™ Plus and Enhanced MicroVersaTrip™ PM Trip Unit	Power+	Rating Plug	Availability by Current Sensor Rating (shaded areas indicate availability)								
					150	400	800	1600	2000	3200	4000	5000	
X				None									
1	•	•		60	1, 2								
2	•	•	•	80									
3	•	•	•	100									
4		•	•	125	1								
5	•	•	•	150		1, 2							
6	•	•	•	200									
7	•	•	•	225									
8	•	•	•	250									
9	•	•	•	300			1, 2						
A	•	•	•	400									
B	•	•	•	450			1, 2						
C	•	•	•	500									
D	•	•	•	600				1, 2					
E	•	•	•	700									
F	•	•	•	750					1, 2				
G	•	•	•	800					1, 2				
H	•	•	•	1000									
J	•	•	•	1100				1, 2					
K	•	•	•	1200									
L	•	•	•	1500					1, 2				
M	•	•	•	1600									
N	•	•	•	2000									
P	•	•	•	2400									
Q	•	•	•	2500									
R	•	•	•	3000									
S	•	•	•	3200								1, 2	
T	•	•	•	3600							1, 2		
V	•	•	•	4000								1, 2	
W	•	•	•	5000									1, 2

¹At coordinate indicated, rating plug and current sensor combination available only on MicroVersaTrip™ trip units. Not available on Power+ trip units.

²At coordinate indicated, rating plug and current sensor combination available only on EntelliGuard™ TU trip units. Not available on Power+ trip units.



Low Voltage Power & Insulated Case Circuit Breakers Section 8

WavePro Low Voltage Power Circuit Breakers

Step 4 Select Charge and Close Operators (Example)

Voltage	Manual	Manual Charge, Remote Close	Electrical Charge & Close
	Product Number Digit	Product Number Digit	Product Number Digit
Manual	X	—	—
120V, 60 Hz	—	1	F
120V, 50 Hz	—	4	H
120V, 50/60 Hz-48Vdc	—	—	N
240V, 60 Hz	—	3	T
240V, 50 Hz	—	6	W
48Vdc	—	A	E
110Vdc	—	B	P
125Vdc	—	C	Q

Step 5 Select Shunt Trip (Example)

Voltage	Product Number Digit
None	X
120V, 60 Hz	1
208V, 60 Hz	2
240V, 60 Hz	3
70V, 60 Hz	4
120V, 50 Hz	5
208V, 50 Hz	6

Step 6 Select Undervoltage Trip OR Electric Lockout (Example)

Voltage	Undervoltage (Instantaneous)	Undervoltage with Time Delay	Electric Lockout
	Product Number Digit	Product Number Digit	Product Number Digit
None	X	X	X
120V, 50/60 Hz	1	—	4
208V, 50/60 Hz	—	3	—
240V, 50/60 Hz	2	3	5
24Vdc	A	—	G
48Vdc	B	—	H
110Vdc	C	—	J
125Vdc	C	E	J

Step 7 Select Auxiliary Switch (Example)

Auxiliary Switch	Product Number Digit
None	X
4-stage Auxiliary Switch	A

Step 8 Select Bell Alarm (Example)

Bell Alarm	Product Number Digit
None	X
Bell Alarm	A
Bell Alarm with Lockout	B

Step 9 Select Second Shunt Trip (Example)

(not available with WPS-50 5000A breakers)

Voltage	Product Number Digit
None	X
120V, 60Hz	1
240V, 60Hz	3
24Vdc	B
110/125Vdc	E

Step 10 Select Additional Options (Example)

A-Disconnect "PM Ready"	Hidden Close Push Button	Operation Counter	Remote Charge Indicator	Product No. Digit
				X (none)
			•	A
		•		B
		•	•	C
	•			D
	•		•	E
	•	•		F
	•	•	•	G
•				H
•			•	J
•		•		K
•		•	•	L
•	•			M
•	•		•	N
•	•	•		P

Example only - ordering information starts on page 8-33.

Note: See WavePro configurator for pricing. Contact a sales representative for configurator.



Low Voltage Power & Insulated Case Circuit Breakers Section 8

WavePro Low Voltage Power Circuit Breakers

Ordering Worksheet

The step-by-step process below allows you to systematically arrive at the product number for your WavePro OEM breaker. As a result, you will get exactly what you need. In addition, this system reduces the cycle time, precisely specifies your requirements, allows tracking during production and ensures accurate invoicing. The final product number will appear on the breaker nameplate, so you can identify all components built into the original breaker and compare breakers within a facility for proper application.

Follow the instructions at each step and transfer the product number digit for each selection to the appropriate boxes in the Product Number Line below. Note: You must submit a complete 15-digit product number when ordering. If you reach a point where no further options or accessories are desired, fill in the remaining product number digits with "X" (for none).

For options not listed, contact your GE Sales Engineer or GE Switchgear Marketing for assistance.

Product Number Line—WavePro Breaker

WavePro Breaker for Substructures		Step 1	Step 2	Step 3	Step 4	Step 5	Step 6	Step 7	Step 8	Step 9	Step 10	Future use, but "X" required
W	S											X

Note: Photocopy this page for each breaker you select and submit it with your order.

Date _____

Name _____

Title _____

Company _____

Address _____

City _____

State _____

Zip _____

Telephone _____

Fax _____

Note: See WavePro configurator for pricing. Contact a sales representative for configurator.



Low Voltage Power & Insulated Case Circuit Breakers Section 8

WavePro Low Voltage Power Circuit Breakers

Basic Selection Information

Table A-1.

WavePro Interrupting Ratings (50/60 Hz ac)

Rated AC Voltage, Nominal (max)	Breaker Type	Frame Size (amps)	Short-Circuit RMS Symmetrical kA		
			Short-Time Withstand	With Instantaneous Trip	Without Instantaneous Trip
600 (635)	WPS-08	800	30	30	30
	WPH-08	800	42	42	42
	WPX-08	800	50	50	50
	WPS-16	1600	42	42	42
	WPH-16	1600	65	65	65
	WPS-20	2000	65	65	65
	WPS-32	3200	65	65	65
	WPH-32	3200	85	85	85
	WPX-32	3200	85	85	85
	WPS-40	4000	85	85	85
	WPX-40	4000	85	85	85
	WPS-50	5000	85	85	85
480 (508)	WPS-08	800	30	30	30
	WPH-08	800	42	42	42
	WPX-08	800	65	65	65
	WPS-16	1600	50	50	50
	WPH-16	1600	65	65	65
	WPS-20	2000	65	65	65
	WPS-32	3200	65	65	65
	WPH-32	3200	85	85	85
	WPX-32	3200	100	100	100
	WPS-40	4000	85	85	85
	WPX-40	4000	100	100	100
	WPS-50	5000	85	85	85
240 (254)	WPS-08	800	30	42	30
	WPH-08	800	42	50	42
	WPX-08	800	50	65	50
	WPS-16	1600	50	65	50
	WPH-16	1600	65	65	65
	WPS-20	2000	65	65	65
	WPS-32	3200	65	85	65
	WPH-32	3200	85	130	85
	WPX-32	3200	100	130	100
	WPS-40	4000	85	130	85
	WPX-40	4000	100	130	100
	WPS-50	5000	85	130	85
WPX-50	5000	100	130	100	

Table A-2.

Fused Breaker Ratings. Max. 600V ac 50/60 Hz.

Frame Size (Amps)	Fuse Rating (Amps) ¹		Interrupting Rating rms Symmetrical kA	Breaker Type
	Min	Max		
800	300	1600	200	WPF-08
1600	450	2500	200	WPF-16
2000	2000	2500 ²	200	WPS-20 ²
3200	2000	4000	200	WPS-32 ²
4000	2000	5000	200	WPS-40 ²
5000	2000	5000	200	WPS-50 ²

¹The maximum fuse rating is the largest fuse that tests show will result in proper performance of the breaker and fuse in combination under short circuit conditions.

²Fuses are mounted on separate fuse roll-out element and are ordered and shipped separately. See Table A-4 on page 8-31.



WavePro Low Voltage Power Circuit Breakers

Basic Selection Information (continued)

Table A-3.

Allowable Fuse Sizes for WavePro WPF and WPS breakers with separate fused rollout elements.

Note: WPS breakers with separate fuse roll-out element require the open fuse lockout (OFLO) device. Select "OFLO only" option for breakers 2000A-5000A: The "OFLO" option is standard on WPF breakers.

Breaker Type	Frame Size	Sensor Rating	Rating Plug	Ferraz-Shawmut Fuse Range (Amps) ¹															
				Class J								Class L							
				300	350	400	450	500	600	800	1000	1200	1600	2000	2500	3000	4000	5000	
WPF-08	800A	150A	Below 150A																
		150A, 400A	150A																
		400A	225A																
		400A, 800A	300A																
		400A, 800A	400A																
		800A	600A																
		800A	700A																
WPF-16 ³	1600A	800A	400A & below																
		800A	500A																
		800A, 1600A	600A																
		800A, 1600A	700A																
		800A, 1600A	800A																
		1600A	1000A																
		1600A	1200A																
WPS-20 ²	2000A	2000A	2000A & below																
WPS-32 ²	3200A	3200A	3200A & below																
WPS-40 ²	4000A	4000A	4000A & below																
WPS-50 ²	5000A	5000A	5000A & below																

¹Class L fuses less than 800A are not UL or CSA listed. Use Class J fuses for 600A and below. 800A-2000A fuses are also available as welder limiters.

²Fuses are mounted on separate fuse roll-out element and are ordered and shipped separately. See Table B-3 on pages 8-41 to 8-42.

³Integrally fused 1600A frame breakers (WPF-16) equipped with 2500A fuses can be furnished with rating plugs from 300-1600A. Breakers equipped with 2500A fuses cannot be modified to accept lower rated fuses. WPF-16 breakers equipped with 2000A and lower fuses cannot be upgraded to 2500A fuses. The maximum trip rating for a WPF-16 breaker is 1200A when furnished with other than 2500A fuses (see chart for min-max fuse rating for each rating plug value). 2500A fuses preclude the use of shutters in the breaker cubicle.

Table A-4.

Product Numbers for Replacement Fuses

Note: These product numbers are for field-installed replacement fuses. Original fuses for 800A and 1600A frame breakers are integral to the breaker and are factory installed. For larger frame breakers (2000A and greater), customers must provide and separately mount fuses.

Class J & Class L Breaker Mounted Fuses for 800A and 1600A Frames

(replace original GE-installed fuses)

Fuse Class	Fuse Rating	Product Number
J	300A	A4J300
J	400A	A4J400
J	450A	A4J450
J	500A	A4J500
J	600A	A4J600
L	800A	A4BY800
L	1000A	A4BY1000BG
L	1200A	A4BY1200BG
L	1600A	A4BY1600BG
L	2000A	A4BY2000
L (Silver)	2500A	A4BQ2500GE

Class L Fuses for Roll-out Elements on 2000A, 3200A, 4000A and 5000A Frames

(replace original customer-installed fuses)

Fuse Rating	Product Number
2000A	A4BY2000-55BA
2500A	A4BY2500-55BA
3000A	A4BY3000-55BA
4000A	A4BY4000-55BA
5000A	A4BY5000-55BA

Welder Limiters for Breaker Mounted Fuses

(replace original GE-installed fuses)

Fuse Rating	Product Number
800A	A4BX800
1600A	A4BX1600BG
2000A	A4BX2000



Low Voltage Power & Insulated Case Circuit Breakers Section 8

WavePro Low Voltage Power Circuit Breakers

EntelliGuard™ TU Trip Unit Characteristics

Envelope Size	Frame Max. Ampere Rating	Sensor Rating (Amperes) (S)	Long Time				Short Time	
			Current Setting (C) (Pick-Up) Multiple of Rating Plug Amperes (X)	Delay (Seconds) ¹		Pick-up (Multiple of Current Settings) (C)	Delay (Seconds)	
				Fuse Type (F-Bands)	Thermal Type (C-Bands)			
800	800	200, 400, 800		0.025	0.20			
				0.025	0.60			
				0.032	1.21			
1600	1600	800, 1000, 1600		0.044	1.61		I^2T in 0.40 ¹	
				0.059	2.41			
				0.078	3.21			
				0.10	4.02			
				0.13	4.82			
2000	2000	2000	0.5 thru 1.0 in Increments of 0.05	0.17	5.62	1.5 thru 9.0 in Increments of 0.05		
				0.22	6.43			
				0.27	7.23			
				0.35	8.04			
				0.44	9.64			
3000	2500	1000, 2000, 2500		0.55	11.20			
	3000	3000		0.69	12.90			
				0.87	14.50			
4000	4000	4000		1.10	16.10		I^2T out 0.10, 0.21, 0.35 ²	
				1.10	17.70			
				1.10	19.30			

Trip Unit Characteristics (continued)

Envelope Size	Adjustable Instantaneous Pick-Up without ST (Multiple of Rating Plug Amperes) (X)	Adjustable Instantaneous Pick-Up with ST (Multiple of Rating Plug Amperes) (X)	High Range Instantaneous (Multiple of Frame Short Time Rating) (H)	Pick-Up (Multiple of Sensor Ampere Rating)	Ground Fault Delay with I^2T in seconds	Delay with I^2T out seconds ³
800	1.5 thru 10.0 in 0.5 increments	1.5 thru 15.0 in 0.5 increments		2.0 thru 0.60 in increments of 0.01		0.10, 0.21, 0.35
1600	1.5 thru 10.0 in 0.5 increments	1.5 thru 15.0 in 0.5 increments		2.0 thru 0.60 in increments of 0.01		0.10, 0.21, 0.35
2000	1.5 thru 10.0 in 0.5 increments	1.5 thru 15.0 in 0.5 increments	1.0	2.0 thru 0.60 in increments of 0.01	.44 at 200% of pick-up at lower limit of band	0.10, 0.21, 0.35
3000	1.5 thru 10.0 in 0.5 increments	1.5 thru 13.0 in 0.5 increments		2.0 thru 0.37 in increments of 0.01		0.10, 0.21, 0.35
4000	1.5 thru 9.0 in 0.5 increments	1.5 thru 9.0 in 0.5 increments		2.0 thru 0.30 in increments of 0.01		0.10, 0.21, 0.35

¹Time delay shown at 600% of current setting at lower limit of band.

²Time delay shown at lower limit of each band. All pick-up tolerances are ±10%.

³Time delay shown at lower limit of each band. Ground fault pick-up not to exceed 1200 amperes



Low Voltage Power & Insulated Case Circuit Breakers Section 8

WavePro Low Voltage Power Circuit Breakers

Selection

Before beginning the selection process, first determine the appropriate WavePro breaker type from Table A-1 on page 8-30. You will need this information to proceed.



Step 1 Select Interrupting Type And Current Sensor

For WPF breaker types, see Table A-3 on page 8-31 for allowable combinations of fuse size, current sensor and rating plugs. From the table below that corresponds to your frame size, select the interrupting type and current sensor for your breaker type. Transfer the product number digits to the box marked **Step 1** in the Product Number Line on the Ordering Worksheet (page 8-29). Note: Power fuses and open fuse lockout (OFLO) devices are included for WPF type 800 and 1600 amp fused breakers.

800 Amp Frame

Breaker Type	Interrupting Type & Rating		Current Sensor			
			No Sensor ¹	150A	400A	800A
WPS-08	Standard	—	1A	1B	1C	1D
WPH-08	High	—	2A	2B	2C	2D
WPX-08	Extended	—	3A	3B	3C	3D
WPF-08	Class J Fuse	300A Fuse	—	AB	AC	AD
		350A Fuse	—	BB	BC	BD
		400A Fuse	—	CB	CC	CD
		450A Fuse	—	DB	DC	DD
		500A Fuse	—	EB	EC	ED
	Class L Fuse	600A Fuse	—	FB	FC	FD
		800A Fuse	—	GB	GC	GD
		1000A Fuse	—	HB	HC	HD
		1200A Fuse	—	JB	JC	JD
	Welder Limiter	1600A Fuse	—	KB	KC	KD
		800A Fuse	—	—	—	ND
			1600A Fuse	—	—	—

¹ Draw-out breaker only, non-automatic.

1600 Amp Frame

Breaker Type	Interrupting Type & Rating		Current Sensor		
			No Sensor ¹	800A	1600A
WPS-16	Standard	—	1E	1F	1G
WPH-16	High	—	2E	2F	2G
WPF-16	Class J Fuse	450A Fuse	—	DF	—
		500A Fuse	—	EF	—
		600A Fuse	—	FF	FG
	Class L Fuse	800A Fuse	—	GF	GG
		1000A Fuse	—	HF	HG
		1200A Fuse	—	JF	JG
		1600A Fuse	—	KF	KG
		2000A Fuse	—	LF	LG
	Welder Limiter	2500A Fuse	—	MF	MG
		800A Fuse	—	NF	NG
		1600A Fuse	—	QF	QG
		2000A Fuse	—	RF	RG

¹ Draw-out breaker only, non-automatic.



Low Voltage Power & Insulated Case Circuit Breakers Section 8

WavePro Low Voltage Power Circuit Breakers

Selection (continued)

Step 1 (continued)

2000 Amp Frame

Breaker Type	Interrupting Type	No Sensor ¹	2000A Sensor
WPS-20	Standard	1H	1J
	OFLO only ²	—	4J

3200 Amp Frame

Breaker Type	Interrupting Type	No Sensor ¹	3200A Sensor
WPS-32	Standard	1K	1L
	OFLO only ²	—	4L
WPH-32	High	2K	2L
WPX-32	Extended	3K	3L

4000 Amp Frame

Breaker Type	Interrupting Type	No Sensor ¹	4000A Sensor
WPS-40	Standard	1M	1N
	OFLO only ²	—	4N
WPX-40	Extended	3M	3N

5000 Amp Frame

Breaker Type	Interrupting Type	5000A Sensor
WPS-50	Standard	1R
	OFLO only ²	4R
WPX-50	Extended	3R

¹ Draw-out breaker only, non-automatic.

² Includes OPEN FUSE LOCKOUT (OFLO) device. Use with separate fuse roll-out element (see TABLE B-2 on page 8-40).



Step 2 Select Trip Unit

From the table below, select your trip unit. Transfer the product number digits to the boxes marked **Step 2** in the Product Number Line to the box marked **Step 2** in the Price Column.

EntelliGuard™ TU Trip Unit Functions

The new EntelliGuard™ TU Trip Unit includes new functions like the Reduced Let Through Energy Instantaneous (RELT) as well as Instantaneous Zone Selective Interlocking (I-ZSI).

WavePro Catalog Number - Code 5

ZSI-GF, ST ³	ZSI-GF, ST & INST.	RELT	Modbus Communication	Monitoring	Data Acquisition	Relaying	Ammeter	Product No. Digit
								X (none -automatic)
							•	N
•							•	P
		•					•	Q
•		•					•	R
		•	•	•	•		•	S
		•	•	•	•	•	•	T
•		•	•	•	•	•	•	V
•		•	•	•	•	•	•	W
	•						•	1
	•	•					•	2
	•	•	•	•	•		•	3
	•	•	•	•	•	•	•	4
			•	•	•	•	•	Z
			•	•	•	•	•	5
•			•	•	•	•	•	6
•			•	•	•	•	•	7
	•		•	•	•	•	•	8
	•		•	•	•	•	•	9

³Requires zone selective interlock module, Type TIM1 (120Vac control voltage).



Low Voltage Power & Insulated Case Circuit Breakers Section 8

WavePro Low Voltage Power Circuit Breakers

Selection (continued)

Step 2 (Cont.)

WavePro Catalog Number - Code 6

Function Code	Long Time	Short Time	Instantaneous	Non-Switchable Instantaneous	Ground Fault ¹	Product No. Digit
LSI	•	•	•			P
LSIG	•	•	•		•	Q
LSIGA	•	•	•		•	1
LSIGDA ²	•	•	•		•	2
LSI ²	•	•		•	•	U
LSIG ²	•	•		•	•	7
LSIGA ²	•	•		•	•	8
LSIGDA ³	•	•		•	•	9

²Switchboard Applications

MicroVersaTrip™ Trip Unit

All MicroVersaTrip™ trip units include integral targets and ammeter display. MicroVersaTrip™ M adds full metering and communications; MicroVersaTrip™ PM adds relaying, metering and communications.

Function Code	Functions								MicroVersaTrip™ Plus	MicroVersaTrip™ PM	
	Long Time	Short Time	Instantaneous	Ground Fault ¹	Defeatable Ground Fault ^{1,3}	Switchable ST or Inst & GF ^{1,3}	ZSI-GF ⁴	ZSI-GF & ST ⁴	Product No. Digits	M	PM
										Product No. Digits	Product No. Digits
LI	•		•						AJ	BJ	CJ
LIG	•		•	•					AK	BK	CK
LIGZ1	•		•	•			•		AL	BL	CL
LIGD ³	•		•		•				AM	BM	CM
LIGDZ1 ³	•		•		•		•		AN	BN	CN
LS	•	•							AA	BA	CA
LSG	•	•		•					AB	BB	CB
LSGZ1	•	•		•			•		AC	BC	CC
LSGZ2	•	•		•				•	AD	BD	CD
LSGD ³	•	•			•				AE	BE	CE
LSGDZ1 ³	•	•			•		•		AF	BF	CF
LSGDZ2 ³	•	•			•			•	AG	BG	CG
LSI	•	•	•						AP	BP	CP
LSIG	•	•	•	•					AQ	BQ	CQ
LSIGX ³	•	•	•	•		•			AR	BR	CR
LSIGZ1	•	•	•	•			•		AS	BS	CS
LSIGZ2	•	•	•	•				•	AT	BT	CT
LSIGD ³	•	•	•		•				AV	BV	CV
LSIGDZ1 ³	•	•	•		•		•		AW	BW	CW
LSIGDZ2 ³	•	•	•		•			•	AY	BY	CY

¹Ground fault is 3-wire/4-wire. If 4-wire ground fault is required, then one of the A-Disconnect options in **Step 10** must be selected and the sensor for the 4th wire (neutral) must be ordered separately. See Table B-5 on page 8-44.

³Function combination is not UL Listed.

⁴Requires zone selective interlock module, Type TIM1 (120Vac control voltage).



Low Voltage Power & Insulated Case Circuit Breakers Section 8

WavePro Low Voltage Power Circuit Breakers

Selection (continued)

Step 3 Select Trip Unit Rating Plug By Current Sensor

Select your rating plug and current sensor combination. Transfer the product number digit to the box marked **Step 3** in the product number line.

Product No. Digits	EntelliGuard™ TU Trip Unit	MicroVersaTrip™ Plus and Enhanced MicroVersaTrip™		Power +	Rating Plug	Availability by Current Sensor Rating (shaded areas indicate availability)								
		PM Trip Unit				150	400	800	1600	2000	3200	4000	5000	
X					None									
1	•	•			60	1, 2								
2	•	•	•		80									
3	•	•	•		100									
4		•	•	•	125	1								
5	•	•	•		150		1, 2							
6	•	•	•		200									
7	•	•	•		225									
8	•	•	•		250									
9	•	•	•		300			1, 2						
A	•	•	•		400									
B	•	•	•		450			1, 2						
C	•	•	•		500									
D	•	•	•		600				1, 2					
E	•	•	•		700									
F	•	•	•		750					1, 2				
G	•	•	•		800					1, 2				
H	•	•	•		1000									
J	•	•	•		1100				1, 2					
K	•	•	•		1200									
L	•	•	•		1500					1, 2				
M	•	•	•		1600									
N	•	•	•		2000									
P	•	•	•		2400									
Q	•	•	•		2500									
R	•	•	•		3000									
S	•	•	•		3200									1, 2
T	•	•	•		3600							1, 2		
V	•	•	•		4000									1, 2
W	•	•	•		5000									1, 2

¹At coordinate indicated, rating plug and current sensor combination available only on MicroVersaTrip™ trip units. Not available on Power+ trip units.

²At coordinate indicated, rating plug and current sensor combination available only on EntelliGuard™ TU trip units. Not available on Power+ trip units.

Step 4 Select Charge and Close Operators

Select your charge and close options. Transfer the product number digits to the box marked **Step 4** in the Product Number Line.

Charge-Close Voltage	Manual	Manual Charge, Remote Close ¹	Electrical Charge & Close ¹
	Product No. Digit	Product No. Digit	Product No. Digit
Manually Operated	X	—	—
120V, 60 Hz	—	1	F
120V, 50 Hz	—	4	H
120V, 50/60 Hz - 48Vdc	—	—	N
240V, 60 Hz	—	3	T
240V, 50 Hz	—	6	W
48Vdc	—	A	E
110Vdc	—	B	P
125Vdc	—	C	Q
250Vdc	—	D	R

¹Requires the selection of a shunt trip in **Step 5** and a 4-stage or higher auxiliary switch in **Step 7**.



Low Voltage Power & Insulated Case Circuit Breakers Section 8

WavePro Low Voltage Power Circuit Breakers

Step 5 Select Shunt Trip

Select your shunt trip. Transfer the product number digit to the box marked **Step 5** in the Product Number Line. (Note: All shunt trips require the selection of a 4- or 7-stage auxiliary switch in **Step 7**. Second shunt trip may be selected in **Step 9**.)

Voltage	Product Number Digit	Voltage	Product Number Digit
None	X	240V/50 Hz	7
120V, 60 Hz	1	—	—
208V, 60 Hz	2	24Vdc	B
240V, 60 Hz	3	48Vdc	D
70V, 60 Hz	4	110/125Vdc	E
120V, 50 Hz	5	250Vdc	F
208V, 50 Hz	6	—	—

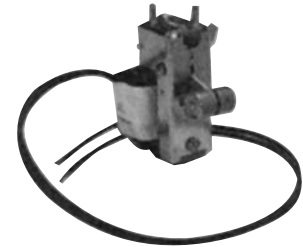

Shunt Trip

Step 6 Select Undervoltage Trip OR Electric Lockout

Select your undervoltage trip or electric lockout option. Transfer the product number digit to the box marked **Step 6** in the Product Number Line.

Voltage	Undervoltage (Instantaneous)	Undervoltage with Time Delay ¹	Electric Lockout
	Product Number Digit	Product Number Digit	Product Number Digit
None	X	X	X
120V, 50/60 Hz	1	—	4
208V, 50/60 Hz	—	3 ²	—
240V, 50/60 Hz	2	3 ³	5
24Vdc	A	—	G
48Vdc	B	—	H
110Vdc	C	—	J
125Vdc	C	E ⁴	J
250Vdc	D	F ⁵	K

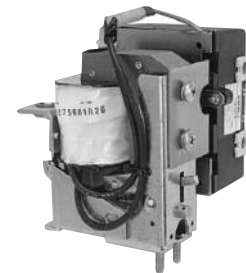

Undervoltage Trip/Electric Lockout

- ¹ Time delay module is provided as a separate component.
² Order static time delay TAKYUVT5 separately. See Table B-6 on page 8-44.
³ Order static time delay TAKYUVT4 separately. See Table B-6 on page 8-44.
⁴ Order static time delay TAKYUVT1 separately. See Table B-6 on page 8-44.
⁵ Order static time delay TAKYUVT2 separately. See Table B-6 on page 8-44.

Step 7 Select Auxiliary Switch

Select your auxiliary switch option. Transfer the product number digit to the box marked **Step 7** in the Product Number Line.

Auxiliary Switch	Product No. Digit
None	X
4-stage Auxiliary Switch	A
7-stage Auxiliary Switch	B

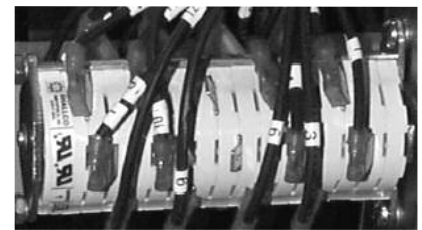

Auxiliary Switch

Step 8 Select Bell Alarm/Push Button Cover

Select your bell alarm option. Transfer the product number digit to the box marked **Step 8** in the Product Number Line.

Bell Alarm	Push Button Cover	Product No. Digit
None	None	X
Bell Alarm	None	A
Bell Alarm with Lockout	None	B
None	CLOSE PB Cover	C
Bell Alarm	CLOSE PB Cover	D
Bell Alarm with Lockout	CLOSE PB Cover	E
None	OPEN PB Cover	F
Bell Alarm	OPEN PB Cover	G
Bell Alarm with Lockout	OPEN PB Cover	H
None	CLOSE & OPEN PB Cover	J
Bell Alarm	CLOSE & OPEN PB Cover	K
Bell Alarm with Lockout	CLOSE & OPEN PB Cover	L

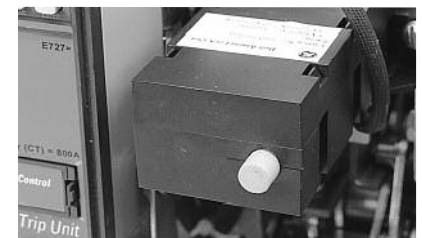

Bell Alarm



Low Voltage Power & Insulated Case Circuit Breakers Section 8

WavePro Low Voltage Power Circuit Breakers

Step 9 Select Second Shunt Trip

If you selected a shunt trip in **Step 5** and require another, select your second shunt trip option. Transfer the product number digit to the box marked **Step 9** in the Product Number Line.

Note: Second shunt trip requires the selection of a 7-stage auxiliary switch in **Step 7**.

Voltage	Product No. Digit
None	X
120V, 60 Hz	1
240V, 60 Hz	3
24Vdc	B
110/125Vdc	E
250Vdc	F

Step 10 Select Additional Options

Select your combination of additional options. Transfer the product number digit to the box marked **Step 10** in the Product Number Line.

A-Disconnect ¹ "PM Ready"	Hidden Close Push Button ²	Operation Counter	Remote Charge Indicator	Product No. Digit
				X (none)
			•	A
		•		B
		•	•	C
	•			D
	•		•	E
	•	•		F
	•	•	•	G
•				H
•			•	J
•		•		K
•		•	•	L

¹The 36-point A-Disconnect is automatically supplied if any of the following options were selected in previous steps:

- zone selective interlock
- shunt trip
- auxiliary switch
- bell alarm
- undervoltage trip
- electrical lockout device
- electric charge and close
- MicroVersaTrip PM trip unit ("M" or "PM" option)

Select the A-Disconnect here only if (1) none of these options were selected in previous steps and 4-wire ground fault is required or (2) none of these options were selected in previous steps and your WavePro breaker is to be "PM ready." "PM ready" wiring includes inputs for 24V dc auxiliary power, communications, and 3 phase voltage.

²Available only on breakers with electrical charge and close option.

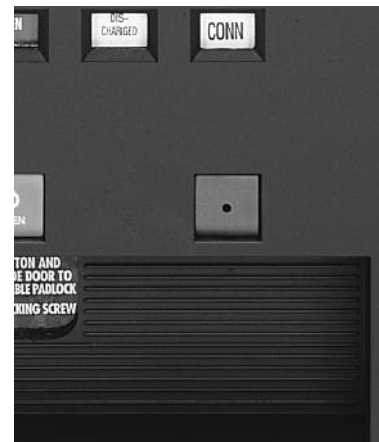

Optional Hidden Close button feature shown



Low Voltage Power & Insulated Case Circuit Breakers Section 8

WavePro Low Voltage Power Circuit Breakers

WavePro Breaker Power+ and MicroVersaTrip™ Plus/PM Rating Plugs

Breaker Frame Size (Amps)	Current Sensor (Amps)	Rating Plug (Amps)	EntelliGuard™ TU	Power+ Rating Plug w/o GF	Power+ Rating Plug with GF	Power+ Rating Plug with Defeatable GF	MicroVersaTrip™ Plus/PM Rating Plug	
800	150	60	GTP0060U0101	N/A	N/A	N/A	TR1B60	
		80	GTP0080U0101	TR1C80	TR1C80GF	TR1C80GFD	TR1B80	
		100	GTP0100U0103	TR1C100	TR1C100GF	TR1C100GFD	TR1B100	
		125	GTP0125U0103	TR1C125	TR1C125GF	TR1C125GFD	TR1B125	
		150	GTP0150U0104	TR1C150	TR1C150GF	TR1C150GFD	TR1B150	
	4000	150	GTP0150U0104	N/A	N/A	N/A	TR4B150	
		200	GTP0200U0204	TR4C200	TR4C200GF	TR4C200GFD	TR4B200	
		225	GTP0225U0306	TR4C225	TR4C225GF	TR4C225GFD	TR4B225	
		250	GTP0250U0407	TR4C250	TR4C250GF	TR4C250GFD	TR4B250	
		300	GTP0300U0408	TR4C300	TR4C300GF	TR4C300GFD	TR4B300	
		400	GTP0400U0410	TR4C400	TR4C400GF	TR4C400GFD	TR4B400	
	800	300	GTP0300U0408	N/A	N/A	N/A	TR8B300	
		400	GTP0400U0410	TR8C400	TR8C400GF	TR8C400GFD	TR8B400	
		450	GTP0450U0612	N/A	N/A	N/A	TR8B450	
		500	GTP0500U0613	TR8C500	TR8C500GF	TR8C500GFD	TR8B500	
		600	GTP0600U0616	TR8C600	TR8C600GF	TR8C600GFD	TR8B600	
		700	GTP0700U0816	TR8C700	TR8C700GF	TR8C700GFD	TR8B700	
		800	GTP0800U0820	TR8C800	TR8C800GF	TR8C800GFD	TR8B800	
	1600	800	300	GTP0300U0408	N/A	N/A	N/A	TR8B300
			400	GTP0400U0410	TR8C400	TR8C400GF	TR8C400GFD	TR8B400
			450	GTP0450U0612	N/A	N/A	N/A	TR8B450
500			GTP0500U0613	TR8C500	TR8C500GF	TR8C500GFD	TR8B500	
600			GTP0600U0616	TR8C600	TR8C600GF	TR8C600GFD	TR8B600	
700			GTP0700U0816	TR8C700	TR8C700GF	TR8C700GFD	TR8B700	
800			GTP0800U0820	TR8C800	TR8C800GF	TR8C800GFD	TR8B800	
1600		600	GTP0600U0616	N/A	N/A	N/A	TR16B600	
		800	GTP0800U0820	TR16C800	TR16C800GF	TR16C800GFD	TR16B800	
		1000	GTP1000U1025	TR16C1000	TR16C1000GF	TR16C1000GFD	TR16B1000	
		1100	GTP1100U1225	N/A	N/A	N/A	TR16B1100	
		1200	GTP1200U1232	TR16C1200	TR16C1200GF	TR16C1200GFD	TR16B1200	
		1600	GTP1600U1640	TR16C1600	TR16C1600GF	TR16C1600GFD	TR16B1600	
2000	2000	750	GTP0750U0820	N/A	N/A	N/A	TR20B750	
		800	GTP0800U0820	N/A	N/A	N/A	TR20B800	
		1000	GTP1000U1025	TR20C1000	TR20C1000GF	TR20C1000GFD	TR20B1000	
		1200	GTP1200U1232	TR20C1200	TR20C1200GF	TR20C1200GFD	TR20B1200	
		1500	GTP1500U1640	N/A	N/A	N/A	TR20B1500	
		1600	GTP1600U1640	TR20C1600	TR20C1600GF	TR20C1600GFD	TR20B1600	
		2000	GTP2000U2050	TR20C2000	TR20C2000GF	TR20C2000GFD	TR20B2000	
3200	3200	1200	GTP1200U1232	TR32C1200	TR32C1200GF	TR32C1200GFD	TR32B1200	
		1600	GTP1600U1640	TR32C1600	TR32C1600GF	TR32C1600GFD	TR32B1600	
		2400	GTP2400U2564	TR32C2400	TR32C2400GF	TR32C2400GFD	TR32B2400	
		3200	GTP3200U3264	TR32C3200	TR32C3200GF	TR32C3200GFD	TR32B3200	
4000	4000	1600	GTP1600U1640	TR40C1600	TR40C1600GF	TR40C1600GFD	TR40B1600	
		2000	GTP2000U2050	TR40C2000	TR40C2000GF	TR40C2000GFD	TR40B2000	
		2500	GTP2500U2564	TR40C2500	TR40C2500GF	TR40C2500GFD	TR40B2500	
		3000	GTP3000U3064	TR40C3000	TR40C3000GF	TR40C3000GFD	TR40B3000	
		3600	GTP3600U4064	N/A	N/A	N/A	TR40B3600	
5000	5000	4000	GTP4000U4064	TR40C4000	TR40C4000GF	TR40C4000GFD	TR40B4000	
		3200	GTP3200U3264	N/A	N/A	N/A	TR50B3200	
		5000	GTP5000U5064	N/A	N/A	N/A	TR50B5000	



Low Voltage Power & Insulated Case Circuit Breakers Section 8

OEM Substructures and Substructure Accessories

Table B-1.

Breaker Substructures

NOTE: Use shallow substructures unless there are other deep substructures in the line-up.

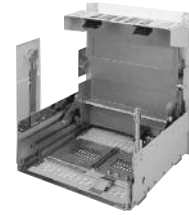

**Large frame sub-structure
(shown with optional accessories)**

Frame Size	Breaker Type	Substructure Type	Substructure Product No.
800	WPS-08	Shallow (29")	WPS08SUBSH1
		Deep (36")	WPS08SUBDP1
	WPH-08	Shallow (29")	WPH08SUBSH1
		Deep (36")	WPH08SUBDP1
	WPX-08	Shallow (29")	WPX08SUBSH1
		Deep (36")	WPX08SUBDP1
WPF-08	Deep (36")	WPF08SUBDP1	
1600	WPS-16	Shallow (29")	WPS16SUBSH1
		Deep (36")	WPS16SUBDP1
	WPH-16	Shallow (29")	WPH16SUBSH1
		Deep (36")	WPH16SUBDP1
	WPF-16	Deep (36")	WPF16SUBDP1
		Deep, with 2500A CL Fuses (36")	WPF16SUBDP2
2000	WPS-20	Shallow (29")	WPS20SUBSH1
		Deep (36")	WPS20SUBDP1
	WPS-20 with OFLO	Shallow (29")	WPS20SUBSH2
		Deep (36")	WPS20SUBDP2
3200	WPS-32	Shallow (29")	WPS32SUBSH1
	WPS-32 with OFLO	Shallow (29")	WPS32SUBSH2
	WPH-32	Shallow (29")	WPH32SUBSH1
	WPX-32	Shallow (29")	WPX32SUBSH1
4000	WPS-40	Shallow (29")	WPS40SUBSH1
	WPS-40 with OFLO	Shallow (29")	WPS40SUBSH2
	WPX-40	Shallow (29")	WPX40SUBSH1
5000	WPS-50	Deep (36")	WPS50SUBDP1
	WPS-50 with OFLO	Deep (36")	WPS50SUBDP2
	WPX-50	Deep (36")	WPX50SUBDP1

Table B-2.

Fuse Rollout Elements and Substructures for Drawout Equipment Substructures
600 Volts AC, 50/60 Hz

NOTE: When used in conjunction with these fuse roll out elements, WavePro Type WPS drawout circuit breaker elements should be equipped with an open fuse lockout (OFLO) device, and the WPS breaker substructure should be ordered with a Keylock Mounting Kit. Key interlock is supplied and mounted by the customer.

Frame Size	Substructure Type	Fuse Roll Out Element (FRE) Only (No Fuses) ^{1,2}	FRE Drawout Substructures ^{2,3}
		Product No.	Product No.
2000A/3200A	Shallow	WP32FRE	WP32FRSUBSH1
4000A	Shallow	WP40FRE	WP40FRSUBSH1
5000A	Deep	WP50FRE	WP50FRSUBSH1

¹Fuse rollouts accept special Class L fuses 2000-5000 Amps. See WavePro Application Guide (DET-167) for additional information.

²UL recognized component.

³Substructures for fuse rollouts include provision for keylock mounting as standard feature.



Table B-3

Breaker Substructures Accessories

Substructure accessories shown assembled are shipped separately for field installation.

Substructure Product Number	Accessory	Accessory Product Number
WPS08SUBSH1 WPH08SUBSH1 WPX08SUBSH1	Secondary Disconnect (bracket only)	WPSDSFSH1
	Secondary Disconnect (one 36-pin block)	WPSDSUBM1
	CT Hardware Mounting Kit, Metering Type (for 3 CTs)	WPCTMTG1
	CT Hardware Mounting Kit, Relaying Type (for 3 CTs)	WPCTMTG2
	One-stage Position Switch Kit	WPPSMTG1
	Three-stage Position Switch Kit	WPPSMTG2
	Shutter Kit	WPSHMTG1
	Padlock Kit	Standard on breaker
	Keylock Mounting Kit (bracket only)	WPSKLMTG1
	Door Interlock Kit	WPDIMTG1
WPS08SUBDP1 WPH08SUBDP1 WPX08SUBDP1	Secondary Disconnect (bracket only)	WPSDSFDP1
	Secondary Disconnect (one 36-pin block)	WPSDSUBM1
	CT Hardware Mounting Kit, Metering Type (for 3 CTs)	WPCTMTG1
	CT Hardware Mounting Kit, Relaying Type (for 3CTs)	WPCTMTG2
	One-stage Position Switch Kit	WPPSMTG3
	Three-stage Position Switch Kit	WPPSMTG4
	Shutter Kit	WPSHMTG2
	Padlock Kit	Standard on breaker
	Keylock Mounting Kit (bracket only)	WPSKLMTG1
	Door Interlock Kit	WPDIMTG1
WPF08SUBDP1	Secondary Disconnect (bracket only)	WPSDSFDP1
	Secondary Disconnect (one 36-pin block)	WPSDSUBM1
	CT Hardware Mounting Kit, Metering Type (for 3 CTs)	WPCTMTG1
	CT Hardware Mounting Kit, Relaying Type (for 3 CTs)	WPCTMTG2
	One-stage Position Switch Kit	WPPSMTG5
	Three-stage Position Switch Kit	WPPSMTG6
	Shutter Kit	WPSHMTG3
	Padlock Kit	Standard on breaker
	Keylock Mounting Kit (bracket only)	WPSKLMTG1
	Door Interlock Kit	WPDIMTG1



Secondary disconnect blocks

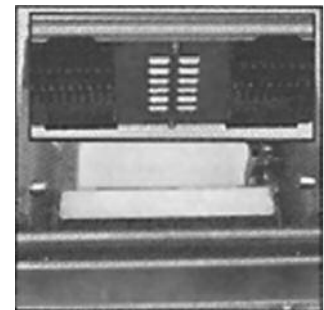

Secondary disconnect bracket with disconnects installed

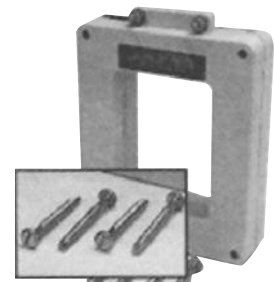

CT mounting hardware kit



Low Voltage Power & Insulated Case Circuit Breakers Section 8

OEM Substructures and Substructure Accessories

Table B-3 (continued)

Breaker Substructures Accessories (cont.)

Substructure Product Number	Accessory	Accessory Product Number
WPS16SUBSH1 WPH16SUBSH1	Secondary Disconnect (bracket only)	WPSDSFSH1
	Secondary Disconnect (one 36-pin block)	WPSDSUBM1
	CT Hardware Mounting Kit, Metering Type (for 3 CTs)	WPCTMTG1
	CT Hardware Mounting Kit, Relaying Type (for 3 CTs)	WPCTMTG2
	One-stage Position Switch Kit	WPPSMTG1
	Three-stage Position Switch Kit	WPPSMTG2
	Shutter Kit	WPSHMTG1
	Padlock Kit	Standard on breaker
	Keylock Mounting Kit (bracket only)	WPSKLMTG1
	Door Interlock Kit	WPDIMTG1
WPS16SUBDP1 WPH16SUBDP1	Secondary Disconnect (bracket only)	WPSDSFDP1
	Secondary Disconnect (one 36-pin block)	WPSDSUBM1
	CT Hardware Mounting Kit, Metering Type (for 3 CTs)	WPCTMTG1
	CT Hardware Mounting Kit, Relaying Type (for 3 CTs)	WPCTMTG2
	One-stage Position Switch Kit	WPPSMTG3
	Three-stage Position Switch Kit	WPPSMTG4
	Shutter Kit	WPSHMTG2
	Padlock Kit	Standard on breaker
	Keylock Mounting Kit (bracket only)	WPSKLMTG1
	Door Interlock Kit	WPDIMTG1
WPF16SUBDP1 (Fuse <2500A)	Secondary Disconnect (bracket only)	WPSDSFDP1
	Secondary Disconnect (one 36-pin block)	WPSDSUBM1
	CT Hardware Mounting Kit, Metering Type (for 3 CTs)	WPCTMTG1
	CT Hardware Mounting Kit, Relaying Type (for 3 CTs)	WPCTMTG2
	One-stage Position Switch Kit	WPPSMTG5
	Three-stage Position Switch Kit	WPPSMTG6
	Shutter Kit	WPSHMTG3
	Padlock Kit	Standard on breaker
	Keylock Mounting Kit (bracket only)	WPSKLMTG1
	Door Interlock Kit	WPDIMTG1
WPF16SUBDP2 (Fuse = 2500A)	Secondary Disconnect (bracket only)	WPSDSFDP1
	Secondary Disconnect (one 36-pin block)	WPSDSUBM1
	CT Hardware Mounting Kit, Metering Type (for 3 CTs)	WPCTMTG1
	CT Hardware Mounting Kit, Relaying Type (for 3 CTs)	WPCTMTG2
	One-stage Position Switch Kit	WPPSMTG7
	Three-stage Position Switch Kit	WPPSMTG8
	Shutter Kit	Contact factory
	Padlock Kit	Standard on breaker
	Keylock Mounting Kit (bracket only)	WPSKLMTG1
	Door Interlock Kit	WPDIMTG1

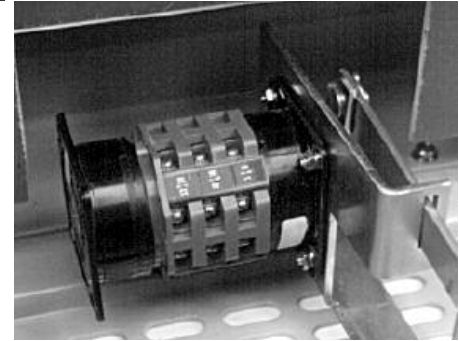

Position switch kit



Shutter kit as installed on substructure



Low Voltage Power & Insulated Case Circuit Breakers Section 8

OEM Substructures and Substructure Accessories

Table B-3. (continued)

Breaker Substructures Accessories (cont.)

Substructure Product Number	Accessory	Accessory Product Number
WPS20SUBSH1 WPS20SUBSH2	Secondary Disconnect (bracket only)	WPSDSFSH1
	Secondary Disconnect (one 36-pin block)	WPSDSUBM1
	CT Hardware Mounting Kit, Metering Type (for 3 CTs)	WPCTMTG1
	CT Hardware Mounting Kit, Relaying Type (for 3 CTs)	WPCTMTG2
	One-stage Position Switch Kit	WPPSMTG1
	Three-stage Position Switch Kit	WPPSMTG2
	Shutter Kit	WPSHMTG1
	Padlock Kit	Standard on breaker
	Keylock Mounting Kit (bracket only)	WPSKLMTG1
Door Interlock Kit	WPDIMTG1	
WPS20SUBDP1 WPS20SUBDP2	Secondary Disconnect (bracket only)	WPSDSFDP1
	Secondary Disconnect (one 36-pin block)	WPSDSUBM1
	CT Hardware Mounting Kit, Metering Type (for 3 CTs)	WPCTMTG1
	CT Hardware Mounting Kit, Relaying Type (for 3 CTs)	WPCTMTG2
	One-stage Position Switch Kit	WPPSMTG3
	Three-stage Position Switch Kit	WPPSMTG4
	Shutter Kit	WPSHMTG2
	Padlock Kit	Standard on breaker
	Keylock Mounting Kit (bracket only)	WPSKLMTG1
Door Interlock Kit	WPDIMTG1	
WPS32SUBSH1 WPS32SUBSH2 WPH32SUBSH1 WPX32SUBSH1	Secondary Disconnect (bracket only)	WPSDLFSH1
	Secondary Disconnect (one 36-pin block)	WPSDSUBM2
	CT Hardware Mounting Kit, Metering Type (for 3 CTs)	WPCTMTG1
	CT Hardware Mounting Kit, Relaying Type (for 3 CTs)	WPCTMTG2
	One-stage Position Switch Kit	WPPSMTG9
	Three-stage Position Switch Kit	WPPSMTG10
	Shutter Kit	WPSHMTG4
	Padlock Kit	WPPKMTG1
	Keylock Mounting Kit (bracket only)	WPSKLMTG2
Door Interlock Kit	WPDIMTG2	
WPS40SUBSH1 WPS40SUBSH2 WPX40SUBSH1	Secondary Disconnect (bracket only)	WPSDLFSH1
	Secondary Disconnect (one 36-pin block)	WPSDSUBM2
	CT Hardware Mounting Kit, Metering Type (for 3 CTs)	WPCTMTG1
	CT Hardware Mounting Kit, Relaying Type (for 3 CTs)	WPCTMTG2
	One-stage Position Switch Kit	WPPSMTG9
	Three-stage Position Switch Kit	WPPSMTG10
	Shutter Kit	WPSHMTG4
	Padlock Kit	WPPKMTG1
	Keylock Mounting Kit (bracket only)	WPSKLMTG2
Door Interlock Kit	WPDIMTG2	
WPS50SUBDP1 WPS50SUBDP2 WPX50SUBDP1	Secondary Disconnect (bracket only)	WPSDLFDP1
	Secondary Disconnect (one 36-pin block)	WPSDSUBM2
	CT Hardware Mounting Kit, Metering Type (for 3 CTs)	WPCTMTG3
	CT Hardware Mounting Kit, Relaying Type (for 3 CTs)	Contact factory
	One-stage Position Switch Kit	WPPSMTG9
	Three-stage Position Switch Kit	WPPSMTG10
	Shutter Kit	WPSHMTG5
	Padlock Kit	WPPKMTG2
	Keylock Mounting Kit (bracket only)	WPSKLMTG3
Door Interlock Kit	WPDIMTG3	



Padlock kit (standard on small frame breakers, optional on large frame breakers)



Keylock mounting kit bracket



Door interlock kit

Continued on next page



Table B-4.

Fuse Rollout Substructure Accessories

Substructure Product Number	Accessory	Accessory Product No.
WP32FRSUBSH1 WP40FRSUBSH1	Secondary Disconnect (bracket only)	WPSDLFSH1
	Secondary Disconnect (one 36-pin block)	WPSDSUBM2
	Metering CT Hardware Mounting Kit (for three CTs)	WPCTMTG1
	Relaying CT Hardware Mounting Kit (for three CTs)	WPCTMTG2
	One-stage Position Switch Kit	WPPSMTG9
	Three-stage Position Switch Kit	WPPSMTG10
	Shutter Kit	WPSHMTG4
	Padlock Kit	WPPKMTG1
	Keylock Mounting Kit (bracket only)	Part of substructure
WP50FRSUBSH1	Door Interlock Kit	WPDIMTG2
	Secondary Disconnect (bracket only)	WPSDLFDP1
	Secondary Disconnect (one 36-pin block)	WPSDSUBM2
	Metering CT Hardware Mounting Kit (for three CTs)	WPCTMTG3
	Relaying CT Hardware Mounting Kit (for three CTs)	Not available
	One-stage Position Switch Kit	WPPSMTG9
	Three-stage Position Switch Kit	WPPSMTG10
	Shutter Kit	WPSHMTG5
	Padlock Kit	WPPKMTG2
	Keylock Mounting Kit (bracket only)	Part of substructure
Door Interlock Kit	WPDIMTG3	

Table B-5.

Neutral Current Transformers (required with 4-wire ground fault).

Frame (Amps)	Circuit Breaker Sensor Amps Rating	Neutral Sensor Rating (Amps)	Product Number
800	150	100-300	TSVG303B
	400, 800	300-800	TSVG508B
1600	800	300-800	TSVG508B
	1600	600-1600	TSVG516B
2000	2000	800-2000	TSVG620B
3200	3200	1200-3200	TSVG832B
4000	4000	1600-4000	TSVG940B
5000	5000	5000	TSVG950B

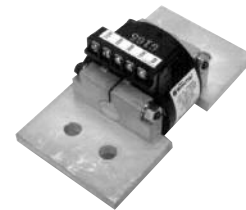

Neutral Current Transformer

Table B-6.

Static Time Delays for Undervoltage Option

Voltage	Static Time Delay Product No. ¹
125Vdc	TAKYUVT1
250Vdc	TAKYUVT2
208 Vac (50/60 Hz)	TAKYUVT5
240 Vac (50/60 Hz)	TAKYUVT4

¹ Must be ordered in conjunction with "Undervoltage with Time Delay" option in Step 6 on page 8-37.

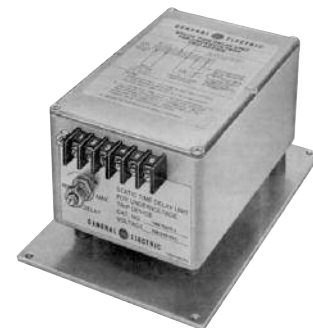

Static Time Delay

Table B-7.

Miscellaneous Accessories

Accessory	Product Number
Breaker Racking Handle—Std 30" Long - Non Swivel	0324B4721G001
Breaker Racking Handle—64" Long - Non Swivel	0324B4721G002
Breaker Racking Handle—30" Long - Swivel Socket	0324B4724G001
Maintenance Closing Handle	568B386G1
Small Frame Lifting Assembly, WP08, 16, 20	0324B4551G001
Large Frame Lifting Assembly, WP32, 40	0247B8961G001
Extra Large Frame Lifting Assembly, WP50	0247B8961G003
Fuse Rollout Out Element Lifting Assembly, 3200A & 4000A	0247B8961G004
Fuse Rollout Element Lifting Assembly, 5000A	0247B8961G005
WavePro Breaker Maintenance Video (Approx. 40 minutes, VHS format) ²	DEV-042

² Order only from Burlington OEM marketing.



Table B-8.

POWER LEADER™ Power Supply

Power supply for furnishing 24Vdc control power for EntelliGuard™ TU, MicroVersaTrip™ Plus and PM trips units.

Description	Product Number	System Requirements (Not included with power supply)
1.5A power supply. Maximum wire length from power supply to trip device is 100 feet. A maximum of 45 trip units may be powered from a single power supply.	PLPS4G01	Input power, 100VA (85-265 Vac or 100-370 Vdc)

Table B-9.

POWER LEADER™ Voltage Conditioner

Conditions and scales 120Vac to 1.76Vac for use by the trip unit for voltage sensing. Provides transient protection. Requires isolation PTs with 120 volt secondary. Supports up to 15 trip units at a maximum distance of 20 feet. Required for PM trip units only.

Description	Product Number	System Requirements (Not included with voltage conditioners)
Supplies isolated bus voltage signal to EntelliGuard™ TU and MicroVersaTrip™ PM trip units.	PLVC1G01	One set of 3 voltage conditioners required for each sensing location. PTs also required.

Table B-10.

The hand-held Portable Battery Pack provides an independent power source for EntelliGuard™ TU, *micro*EntelliGuard™, MicroVersaTrip™ Plus and MicroVersaTrip™ PM trip units as an alternative to a test set. The battery pack is used to power up the trip unit to set or adjust trip set points when the breaker is on the bench or otherwise not powered up. For *micro*EntelliGuard™ trip units, the battery pack connects to the trip unit through the 15-pin connector. A battery pack adapter cable is required. For MicroVersaTrip™ Plus and MicroVersaTrip™ PM trip units, the battery pack connects to the trip unit through the rating plug test jack. The battery pack requires three standard 9 Vdc alkaline batteries (not included).

Description	Product Number
MicroVersaTrip™ Plus and PM Portable Power Pack	TVPBP
EntelliGuard™ TU, <i>micro</i> EntelliGuard™ Battery Pack Adapter Cable	TVPBPACC

Table B-11.

MicroVersaTrip™ Rating Plug Removal Tool

Description	Product Number
MicroVersaTrip™ Rating Plug Removal Tool	TRTOOL

Table B-12.

Portable Test Set

This portable, battery powered test kit provides self-tests and functional trip/no trip tests. It also provides defeat of the ground fault function and be used in conjunction with high current test equipment. Interface is via a plug on the front of the trip units, and tests can be conducted with the breaker in service. Test sets use either 120Vac power source or internal batteries (not included).

Description	Trip Unit Type	Product Number
Portable Test Set	MicroVersaTrip™ only	TVRMS2
	EntelliGuard™ TU and <i>micro</i> EntelliGuard™	GTUTK20



Portable Test Set - MicroVersaTrip™



Portable Test Set - EntelliGuard™ TU and *micro*EntelliGuard™



Low Voltage Power & Insulated Case Circuit Breakers Section 8

OEM Substructures and Substructure Accessories

Table B-13.

Metering and Relaying Current Transformers for 800-5000A Substructures, 600 Vac, 50/60 Hz

Breaker Frame Size	Ampere Ratio (I):5	Metering Product Number	Metering & Relaying Product Number
800A 1600A 2000A	100	75C149640P001	75C149640P025
	150	75C149640P002	75C149640P026
	200	75C149640P003	75C149640P027
	250	75C149640P004	75C149640P028
	300	75C149640P005	75C149640P029
	400	75C149640P006	75C149640P030
	500	75C149640P007	75C149640P031
	600	75C149640P008	75C149640P032
	800	75C149640P010	75C149640P034
	1000	75C149640P011	75C149640P035
	1200	75C149640P012	75C149640P036
	1500	75C149640P013	75C149640P037
	1600	75C149640P014	75C149640P038
	2000	75C149640P015	75C149640P039
	2500	75C149640P016	75C149640P040
3200A 4000A	2000	75C149640P020	75C149640P044
	2500	75C149640P021	75C149640P045
	3000	75C149640P022	75C149640P046
	3200	75C149640P023	75C149640P047
	4000	75C149640P024	75C149640P048
5000A	5000	75C149640P049	Consult Factory



Switchgear Module and Trolley for use with Gerapid High-Speed DC Circuit Breakers

GE offers UL recognized OEM switchgear modules and drawout trolleys for use with Gerapid High-Speed DC circuit breakers. Modules come factory assembled, and can be used to form lineups of DC switchgear. The OEM provides required bussing, wiring, controls and covers necessary to complete the switchgear. The Trolley is designed to accept Gerapid DC breakers, interface with the OEM Module and includes pre-wired secondary control harness and required interlocking.

Key Module Features include:

- NEMA 1, zinc-plated bolted steel frame construction
 - 26" W x 87" H x 59" D
 - Optional 71" depth for extra bus and cable space
 - Rated for 800VDC, 200kA peak withstand
- Copper stationary primary stabs available for 2500A thru 6000A
- Side-covers and doors painted ANSI Grey
- Insulated safety shutters with padlock provisions
- Secondary control compartment with hinged, padlockable door
 - 21.5" H x 22.8" W x 8.6" D
- Breaker secondary control wiring harness and plug included
- Designed to meet ANSI C37.20.1 requirements
- UL Recognized

Key Trolley Features include:

- Designed for use with Gerapid OEM Modules
- Complete drawout trolley for Gerapid UL Listed 2508 4008, 5008 and 6008 breakers
- Breaker secondary control wiring harness & socket included
- Breaker compartment door is hinged and fixed to trolley structure (dead front)
- Trolley front cover (door) has inspection window to view breaker position indicator and operations counter
- Trolley is grounded in all positions
- Designed to meet ANSI C37.20.1 and C37.14 interlocking and other requirements
- Standard manual racking drive
- Optional motor drive racking, 230VAC/60HZ
- UL Recognized

OEM Benefits

- Simplified OEM Modules (substructures)
- Complete drawout DC breaker solution
- Trolleys and Modules are UL recognized.
- Outlines available in PDF and as AutoCAD templates for OEMs
- All breaker controls prewired to secondary control disconnect
- ANSI C37.20.1 and C37.14 required interlocking included
- Accessories available, including various covers and hardware kits

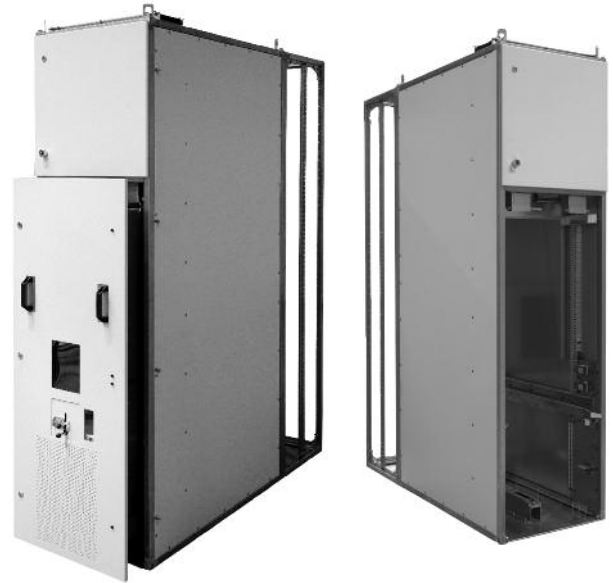

OEM Switchgear Modules



Drawout Trolley



Gerapid High-Speed Circuit Breaker



Low Voltage Power & Insulated Case Circuit Breakers Section 8

OEM Substructures and Substructure Accessories

Substructures

Description	Product Number
Gerapid OEM Module-4kA-1500mm	700689
Gerapid OEM Module-6kA-1500mm	700690
Gerapid OEM Module-4kA-1800mm	700691
Gerapid OEM Module-6kA-1800mm	700692

Breaker Trolley

Description	Product Number
Gerapid OEM Trolley-motor driven	700693
Gerapid OEM Trolley-manual drive	700694

Accessories

Description	Product Number
Racking Handle	700695
Rear Side Cover 1500mm Depth Unit	700696
Rear Side Cover 1800mm Depth Unit	700697
Control Wireway Connector	700698
Control Wireway Cover	700699
Section Bolting Hardware Kit	289158
Cover Attachment Hardware kit	289160
Door Hinges Kit	289709

To configure Gerapid OEM Modules and DC Circuit Breakers, visit our web\ wizard configuration tool at:
http://www.geindustrial.com/cwc/Dispatcher?REQUEST=PRODUCTS&id=gerapid&lang=en_US



Trip Units

EntelliGuard™ TU Trip Unit Features

EntelliGuard™ TU Trip Unit

New capabilities in the EntelliGuard™ TU Trip Unit provide ultimate system reliability and selectivity without sacrificing circuit protection. This superior addition enhances the circuit breakers with a Waveform Recognition Instantaneous Algorithm that eliminates costly downtime due to nuisance tripping. It enables harmonic analysis four cycles prior and after an event, and discerns whether a downstream breaker/fuse is clearing the fault. The unit also includes Instantaneous Zone Selective Interlocking (I-ZSI) (can be used as a feeder and downstream device with a power circuit breaker upstream) which delivers simultaneous and independent ZSI of Short Time, Ground Fault and Instantaneous protection, providing the ability to overlap the Instantaneous on the Main and Feeder breakers. Together, these innovative abilities achieve HRC2 with currents as high as 100kA with simultaneous flash protection and selectivity.

The EntelliGuard™ TU Trip Unit offers optimum circuit safety and arc flash protection with the Reduced Energy Let-Through function, providing a faster instantaneous trip that may be used if faster and more sensitive protection is required temporarily. It is commonly referred to as an "Arc Flash Switch" or "Maintenance Switch".

The new and improved trip unit design delivers selectivity tools not previously available in GE circuit breakers:

Exclusive EntelliGuard™ TU Trip Unit Features

Designed for Flexibility

- A wide range of continuous adjustment Long Time delays ensure the circuit breaker can be exactly adjusted in to your selectivity and protection needs.
- Multiple Short Time diagonal bands tune your protection to exactly where it needs to be.
- Flexible time current settings and curves -Standard Long Time characteristics exactly mimic the curve of a thermal magnetic circuit breaker.
- Flexible Time Current Curves: 44 Long Time Shapes I^2T and I^4T (fuse), 3 Short Time I^2T slopes, Short Time adjustable in 55 ms increments, a Selective Ground Fault curve

Instantaneous Protection

- Instantaneous pick-up is adjustable up to 15 times the plug rating on frames 800-2000A, 13 times on 3000A frames and up to 9 times on 4000A frames.
- A separately adjustable fast instantaneous trip- useful for when the circuit must provide the best possible protection and arc flash performance while sustaining normal load.
- An override instantaneous - provides fast tripping for the largest bolted fault currents to minimize potential damage.
- Up to 17 Short Time bands allow you to set your circuit breaker to sustain load requirements without slowing protection.
- Ground Fault Alarm via I/O or Modbus Communications
- Ground fault protection with faster time bands, multiple slopes and the ability to coordinate a 1200A ground fault with an 800A circuit breaker – a ratio four times better than in previous generation trip units



Maintenance and Diagnostics

- Universal trip plug fits any trip unit.
- Flexible serial communication via Modbus RTU
- Integrates directly into GE's EnerVista™ Power Management System.
- Large backlit LCD with detailed, easy-to-see descriptions.
- Health status via breaker LED indicating normal operation, errors, pickup, and trips while providing non-volatile memory with a continuous self-testing microprocessor
- Lithium battery to eliminate need for external power for set-up and review
- 10 event Log with Date/Time Stamp: Stores the last 10 events. Date/Time with 24Vdc Power.
- Thermal Memory
- WaveForm Capture: 40 Samples/Cycle, 4 cycles prior and 4 cycles post event in COMTrade format.
- Free set-up software

To learn more about EntelliGuard™ TU Trip Unit features see brochure DEA-461C.



Low Voltage Power & Insulated Case Circuit Breakers Section 8

Trip Units

Power+ Trip Unit Features

Power+ Trip Unit Systems

The Power+ trip unit system for insulated case circuit breakers consist of the trip unit, the trip actuator, current sensors and rating plugs. The term “trip unit system” applies to the combination of these four components which form the solid-state circuit breaker tripping system.

Power+ trip units provide a complete range of standard and optional overcurrent and ground-fault protective functions.



True RMS Sensing

The Power+ trip unit continues to use GE’s proven technique of measuring true rms currents of both sinusoidal and harmonically distorted waveforms. The frequent sampling (48 times per cycle per phase) allows precise calculations of true rms current. The sampling rate allows waveform measurements up to the 11th harmonic. GE’s true rms sensing avoids potential underprotection or overprotection problems associated with peak-sensing tripping systems.

Accessory Integration

Four accessories are integrated through the Power+ trip unit. Drop-in shunt trip (with or without lockout), bell alarms (with or without lockout) and the undervoltage release modules fit into keyed pockets. They operate through the trip units, and not through any external mechanisms. All accessory wiring is pre-wired to secondary terminals, and no user wiring is necessary. When activated, the shunt trip (with or without lockout) and undervoltage release modules send a signal to the trip unit to energize the trip actuator and open the breaker.



Power+ Trip Target Module

Trip Target Module (Optional)

View Button: Press the VIEW button to check the trip unit status.

Reset Button: Press the RESET button to clear any target that is set.

Battery check: Target modules use two standard, 3V, 16mm x 1.6mm, lithium batteries for viewing target information. Battery life depends upon use, but may be estimated at one year. When the batteries are energized, depressing the VIEW button will illuminate either a set target LED, i.e., LT or the BAT LED. Once target indicators are cleared, battery status is indicated by the BAT LED. Replacement batteries include Panasonic CR1616, Eveready E-CR1616BP, or Duracell DL1616B, which may be purchased commercially.

Long-time pickup: The long-time pickup indicator moves through two transitions. As the current in any phase reaches 95% of its setpoint; the LTPU LED begins to flash. As current increases, flashing frequency increases, until 100% of the pickup point is reached. At that moment, the LTPU LED stays on continuously until the long-time delay times out. Once the breaker has tripped on long-time, the OVL target will be stored in memory. To view the trip, press the VIEW button. To clear the target, press the RESET button.

Short-time and instantaneous trips: Short-time and instantaneous trips share the same trip target. The LTPU LED is not illuminated, since the time intervals between pickup and tripping are too short for either function. Once the breaker has tripped on short-time or instantaneous, the short target will be stored in memory. To view the trip, press the VIEW button. To clear the target, press the RESET button.

Ground fault trip (Target02 only): The trip target for a ground fault trip is the GF LED. To view the trip, press the view button. To clear the target, press the RESET button.

Health monitor: Trip unit health status “okay” is illustrated by slow blinking of the LTPU LED. It may be seen by depressing and holding the VIEW button. Sufficient power must be supplied to the trip unit via external test kit, power pack, or current transformers for the health monitor to be operational.

Standard and Optional Protective Functions

Standard and optional protective functions are available for Power+ trip units. The breaker settings are programmed in multiples of “X” (rating plug ampere values), “S” (current sensor ampere rating values), and “C” (the long-time setting in amperes—multiply long-time setting by rating plug ampere rating).

Standard

- Adjustable Long-Time (L) Pickup, 0.5 - 1.0X, with four delay bands.
- Adjustable Instantaneous (I) Pickup, 1.5 - 15X.1

Options

- Overload, Short Circuit, and Short-Time local trip indicators with overload pickup warning and health monitor.
- Adjustable Short-Time (S) Pickup, 1.5 - 9.0C, and delay (3 bands) with I²t ON/OFF selection.
- Adjustable Ground Fault (G) Pickup, 0.2 - 0.6S, and delay¹ (3 bands) with I²t ON/OFF selection and trip indicator.
- Upgradeable Ground Fault function with use of appropriate ground fault rating plug.

¹Limited by breaker frame size above 2000A.



Trip Units

Enhanced MicroVersaTrip™ Trip Unit Features

Enhanced MicroVersaTrip™ Trip Units

Enhanced MicroVersaTrip™ Plus and MicroVersaTrip™ PM trip units give you two new ways to monitor and control the circuit breaker with unprecedented ease. Through the simple keypad, the trip unit lets you program and display a variety of functions including tripping characteristics, remote communications, status information and protective relaying, and allows integration with GE POWER LEADER™ Power Management Systems. The trip unit display also allows viewing of many standard metering parameters as well as pickup alarms, trip target indications and fault status information.

Enhanced MicroVersaTrip™ Plus and MicroVersaTrip™ PM trip units continue to use GE's proven technique of measuring true rms currents (and voltages for MicroVersaTrip™ PM trip units) of both sinusoidal and harmonically distorted waveforms. The frequent sampling (64 times per cycle) allows precise calculations of true rms current. The sampling rate allows waveform measurements up to the 31st harmonic to achieve accuracies of 99%. GE's true rms sensing avoids potential underprotection or overprotection problems associated with peak-sensing tripping systems.

The enhanced trip unit design includes a wide range of functions and adds many new features:

UL Listed Field-Interchangeable

Non-volatile trip targets display/Cold setup capability

- Replaceable long-life batteries provide trip target indications and cold setup capability—without the need for external power or a battery pack.

Trip operations counter

- The number of long-time, short-time, instantaneous and ground fault trips are individually counted and displayed.

Trip information

- On overcurrent faults, the trip unit displays fault pickup, the type of fault, the magnitude of the fault current and the phase the fault occurred on.
- Display indicates when a shunt trip or undervoltage release trip has opened the breaker.

New display

- Ergonomic, 5-button keypad
- New targets with international symbols
- High-resolution LCD display for local 3-phase ammetering
- New status and setup displays for greater ease of use
- True rms sensing for accurate response to high harmonic content waveforms for Long-Time, Short-Time, and Ground Fault protection.
- 50/60 Hz operation.
- Interchangeable, UL Listed trip units and rating plugs with test set jack for TVRMS2 test set.
- EMI immunity per ANSI C37.90.



Enhanced MicroVersaTrip™ Plus and MicroVersaTrip™ PM Trip Units have been specifically designed to integrate with the extensive capabilities offered by circuit breakers.

Features exclusive to MicroVersaTrip™ PM Trip Units

Communications

- All information can be viewed on the LCD display or communicated over a POWER LEADER™ Power Management System network.

Demand/peak demand

- The trip unit can display a rolling average of power demand and peak power demand at user-selected intervals from 5 to 60 minutes.

Local and remote metering

- Amps, volts, frequency
- Real power, total power
- Accumulated energy

Protective relays include:

- Current and voltage unbalance
- Overvoltage
- Undervoltage
- Power reversal
- Power reversal direction setup



Low Voltage Power & Insulated Case Circuit Breakers Section 8

Trip Units

Trip Unit Characteristics

EntelliGuard™ TU Trip Unit Characteristics

Envelope Size	Frame Max. Ampere Rating	Sensor Rating (Amperes) (S)	Long Time				Short Time	
			Current Setting (C) (Pick-Up) Multiple of Rating Plug Amperes (X)	Delay (Seconds) ¹		Pick-up (Multiple of Current Settings) (C)	Delay (Seconds)	
				Fuse Type (F-Bands)	Thermal Type (C-Bands)			
800	800	200, 400, 800	0.5 thru 1.0 in Increments of 0.05	0.025	0.20	1.5 thru 9.0 in Increments of 0.5	i^2T in Minimum - 0.046 Intermediate - 0.186 Maximum - 0.418 ¹	
				0.025	0.60			
				0.025	1.21			
1600	1600	800, 1000, 1600		0.032	1.61			
				0.044	2.41			
				0.059	3.21			
2000	2000	2000		0.078	4.02			
				0.10	4.82			
				0.13	5.62			
3000	2500	1000, 2000, 2500		0.17	6.43			i^2T out 0.025, 0.033, 0.042, 0.058, 0.092, 0.117, 0.158, 0.183, 0.217, 0.350, 0.417 ²
				0.22	7.23			
	3000	3000		0.27	8.04			
			0.35	9.64				
	4000	4000	4000	0.44	11.20			
				0.55	12.90			
0.69				14.50				
			0.87	16.10				
			1.10	17.70				
				19.30				

Trip Unit Characteristics (continued)

Envelope Size	Adjustable Instantaneous Pick-Up without ST (Multiple of Rating Plug Amperes) (X)	Adjustable Instantaneous Pick-Up with ST (Multiple of Rating Plug Amperes) (X)	RELT without ST	RELT with ST	Pick-Up (Multiple of Sensor Ampere Rating)	Ground Fault ³		
						Delay with I^2T in Seconds	Slope Bands	Fixed Delay
800	2.0 thru 10.0 in 0.5 increments	2.0 thru 15.0 in 0.5 increments	1.5 thru 10.0 in 0.5 increments	1.5 thru 15.0 in 0.5 increments	0.20 thru 0.60 in increments of 0.01	.44 at 200% of pick-up at lower limit of band	i^2T - .385	0.058
								0.092
1600	2.0 thru 10.0 in 0.5 increments	2.0 thru 15.0 in 0.5 increments	1.5 thru 10.0 in 0.5 increments	1.5 thru 15.0 in 0.5 increments	0.20 thru 0.60 in increments of 0.01			0.117
								0.158
2000	2.0 thru 10.0 in 0.5 increments	2.0 thru 15.0 in 0.5 increments	1.5 thru 10.0 in 0.5 increments	1.5 thru 15.0 in 0.5 increments	0.20 thru 0.60 in increments of 0.01			0.183
								0.217
3000	2.0 thru 10.0 in 0.5 increments	2.0 thru 13.0 in 0.5 increments	1.5 thru 10.0 in 0.5 increments	1.5 thru 13.0 in 0.5 increments	0.20 thru 0.37 in increments of 0.01			0.35
								0.417
4000	2.0 thru 9.0 in 0.5 increments	2.0 thru 9.0 in 0.5 increments	1.5 thru 9.0 in 0.5 increments	1.5 thru 9.0 in 0.5 increments	0.20 thru 0.30 in increments of 0.01			0.517
								0.617
								0.717
								0.817
						0.917		

¹Time delay shown at 600% of current setting at lower limit of band.

²Time delay shown at lower limit of each band. All pick-up tolerances are ±10%.

³Time delay shown at lower limit of each band. Ground fault pick-up not to exceed 1200 amperes

Additional Features and Characteristics of the EntelliGuard™ TU Trip Unit

Function	Description	Product Number Digit															
		1	2	3	4	5	6	7	8	9	X	A ⁴	B ⁴	C ⁴	D ⁴	E ⁴	
Metering																	
Communications	Modbus Communications Bus Link		•														
Amperes (A, kA) ²	Selectable Phase Current ±2.5%	•	•		•	•	•	•			•	•	•	•	•	•	
Voltage (V)	L-L or L-N Volts ±1.5%				•	•	•	•				•	•	•	•	•	
Energy (kWh, Mwh, GWh)	Total Energy Usage on Brkr ±4%				•	•	•	•				•	•	•	•	•	
Real Power (kW/MW)	L-L or L-N Power ±4%				•	•	•	•				•	•	•	•	•	
Total Power (kVA/MVA)	L-L or L-N Power ±4%				•	•	•	•				•	•	•	•	•	
Frequency (Hz)	Circuit Frequency ±1Hz				•	•	•	•				•	•	•	•	•	
Demand & Peak Demand (kW)					•	•	•	•				•	•	•	•	•	
Relaying																	
Under Voltage Trip	Adjustable pickup, 50-90%					•										•	
	Adjustable delay, 1-15 seconds OFF															•	
Over Voltage Trip	Adjustable pickup, 110-150%					•										•	
	Adjustable delay, 1-15 seconds OFF															•	
Voltage Unbalance	Adjustable pickup, 10-50%															•	
	Adjustable delay, 1-15 seconds OFF															•	
Current Unbalance	Adjustable pickup, 10-990kW					•										•	
	Adjustable delay, 1-15 seconds Off															•	
	Power Reversal Direction															•	
Data Acquisition - Waveform Capture																	
RELT		•	•		•	•	•	•								•	•

⁴Used when Ground Fault Alarm is needed via the output contact



Low Voltage Power & Insulated Case Circuit Breakers Section 8

Trip Units

Trip Unit Characteristics (continued)

Additional Features and Characteristics of the EntelliGuard™ TU Trip Unit

Product No. Digits	Zone Selective Interlocking	Circuit Breaker
Z	ZSI, Short time and GF; user selectable	•
T	Z + IOC ZSI; user selectable	• ¹
X	NONE SELECTED	•

¹Instantaneous out only

Power+ Trip Unit Characteristics

Envelope Size	Frame Max. Ampere Rating	Sensor Rating (Amperes) (S)	Long-Time		Short-Time	
			Current Setting (C) (Pick-Up) Multiple of Rating Plug Amperes (X)	Delay ² (Seconds 4 Bands)	Pick-up (Multiple of Current Setting) (C)	Delay (Seconds 3 Bands)
2000	800	200, 400, 800	0.5, 0.6, 0.7, 0.8, 0.9, 0.95 and 1.0	2.4, 4.9, 9.8, 20	1.5, 2.0, 2.5, 3.0, 4.0, 5.0, 7.0, and 9.0	I^2T in ² .10, .21, .35
	1600	800, 1000, 1600				I^2T out ³ .10, .21, .35
	2000	2000				
3000	2500, 3000	1000, 2000, 2500, 3000				
4000	4000	4000				

Power+ Trip Unit Characteristics (continued)

Envelope Size	Adjustable Instantaneous Pick-Up without ST (Multiple of Rating Plug Amperes) (X)	Adjustable Instantaneous Pick-Up with ST (Multiple of Rating Plug Amperes) (X)	Ground Fault	
			Pick-Up (Multiple of Sensor Ampere Rating)	Delay ⁴ (Seconds 3 Bands)
2000	1.5 thru 10.0	1.5 thru 15.0	0.20 thru 0.60	I^2T in ⁵ .10, .21, .35
			0.20 thru 0.60	I^2T out ³ .10, .21, .35
			0.20 thru 0.60	
3000	1.5 thru 10.0	1.5 thru 13.0	0.20 thru 0.37	
4000	1.5 thru 9.0	1.5 thru 9.0	0.20 thru 0.30	

Enhanced MicroVersaTrip™ Plus and PM Trip Unit Characteristics

Envelope Size	Frame Max. Ampere Rating	Sensor Rating (Amperes) (S)	Long-Time		Short-Time	
			Current Setting (C) (Pick-Up) Multiple of Rating Plug Amperes (X)	Delay ³ (Seconds)	Pick-up (Multiple of Current Setting) (C)	Delay (Seconds)
800	800	200, 400, 800	0.5 thru 1.0 in increments of 0.05	2.4, 4.9, 9.8, 20	1.5 thru 9.0 in increments of 0.5	I^2T in ² 0.40
1600	1600	800, 1000, 1600				I^2T out ³ .10, .21, .35
2000	2000	2000				
3000	2500, 3000	1000, 2000, 2500				
4000	4000	4000				

Trip Unit Characteristics (continued)

Envelope Size	Adjustable Instantaneous Pick-Up without ST (Multiple of Rating Plug Amperes) (X)	Adjustable Instantaneous Pick-Up with ST (Multiple of Rating Plug Amperes) (X)	High Range Instantaneous (Multiple of Frame Short-Time Rating) (H)	Ground Fault		
				Pick-Up (Multiple of Sensor Ampere Rating)	Delay With I ² T In Seconds	Delay ⁴ With I ² T Out Seconds
800	1.5 thru 10.0 in 0.5 increments	1.5 thru 15.0 in 0.5 increments		0.20 thru 0.60 in increments of 0.01		
1600	1.5 thru 10.0 in 0.5 increments	1.5 thru 15.0 in 0.5 increments		0.20 thru 0.60 in increments of 0.01		
2000	1.5 thru 10.0 in 0.5 increments	1.5 thru 15.0 in 0.5 increments	1.0	0.20 thru 0.60 in increments of 0.01	.44 at 200% of pick-up at lower limit of band	.10, .21, .35
3000	1.5 thru 10.0 in 0.5 increments	1.5 thru 13.0 in 0.5 increments		0.20 thru 0.37 in increments of 0.01		
4000	1.5 thru 9.0 in 0.5 increments	1.5 thru 9.0 in 0.5 increments		0.20 thru 0.30 in increments of 0.01		

²Time delay shown at 600% of current setting at lower limit of band.

³Time delay shown at lower limit of each band. All pick-up tolerances are ± 10%.

⁴Time delay shown at lower limit of each band. Ground fault pick-up not to exceed 1200 amperes.

⁵Time delay shown at 200% of pick-up at lower limit of band.

X = Rating plug amps
S = Sensor amp rating
C = Long-time current setting (pick-up)
H = Short-Time Rating



Low Voltage Power & Insulated Case Circuit Breakers Section 8 Trip Units

Trip Unit Characteristics (continued)

Additional Features and Characteristics Exclusive to the Enhanced MicroVersaTrip™ PM Trip Unit¹

Function	Description	Trip Unit Suffix		
		M (Metering)	P (Relaying)	PM (Metering & Relaying)
Communications	—POWER LEADER Communications Bus Link	STD	STD	STD
Amperes (A, kA) ²	Selectable Phase Current ±2.5%	STD	STD	STD
Voltage (V)	L-L or L-N Volts ±1.5%	•		•
Energy (kWh, MWh, GWh)	Total Energy Usage on Brkr ±4%	•		•
Real Power (kW/MW)	L-L or L-N Power ±4%	•		•
Total Power (kVA/MVA)	L-L or L-N Power ±4%	•		•
Frequency (Hz)	Circuit Frequency ± 1Hz	•		•
Demand & Peak Demand (kW)		•		•
Under Voltage Trip	—Adjustable pickup 50-90% —Adjustable delay, 1-15 seconds OFF		•	•
Over Voltage Trip	—Adjustable pickup, 110-150% —Adjustable delay, 1-15 seconds OFF		•	•
Voltage Unbalance	—Adjustable pickup, 10-50% —Adjustable delay, 1-15 seconds OFF		•	•
Current Unbalance	—Adjustable pickup, 10-50% —Adjustable delay, 1-15 seconds OFF		•	•
Power Reversal	—Adjustable pickup, 10-990 kW —Adjustable delay, 1-15 seconds OFF —Power Reversal Direction		•	•

¹MicroVersaTrip™ PM functions require 24 Vdc control power.

²Ampere reading also standard on MicroVersaTrip™ Plus trip units.



Low Voltage Power & Insulated Case Circuit Breakers Section 8 Trip Units

Product Number Nomenclature System

EntelliGuard™ TU Trip Unit for EntelliGuard™ G Breakers Product Number Structure

Digit	G	G	M	1	6	L	4	X	6	A	R	X	X	X	X
	1 and 2		3	4 and 5		6 and 7		8	9	10	11	12	13	14	15
Trip Unit Form	EntelliGuard™														
Frame Ratings															
Sensor Rating	1600											Future Use			
Overcurrent Ground Fault Protection	LSIG (S, switchable) (I, switchable ANSI only)														
Zone Selective Interlocking	Blank														
Advanced Features and Communications	Monitoring + Data Acquisition, Modbus Protocol + RELT											Manual / Auto Trip Reset (EntelliGuard™ G only)			
												Auto Reset/Reclose			
												Factory or Field Install Replacement Trip Unit			

Digit 1 and 2 Trip Unit Form/Family

Circuit Breaker Type	Code
Power Break™ I (UL)	GA
Power Break™ II (UL)	GB
AKR (ANSI)	GC
WP (ANSI)	GW
Mpact Low (IEC)	GL
Mpact 24-48V (IEC)	GH
Mpact 120-240V (IEC)	GQ
EntelliGuard™ G ACB (ANSI)	GG
EntelliGuard™ G ACB (UL)	GU
EntelliGuard™ G ACB (IEC)	GT
EntelliGuard™ G Universal Spare Trip	G1
Type A Conversion Kits (ANSI)	G2
EntelliGuard™ G Switch (IEC)	G3

Digit 4 and 5 Sensor Rating

Sensor Rating	Code
UNIV ¹	00
400	04
600 ²	06
800	08
1000 ²	10
1200 ²	12
1600	16
2000	20
2500 ²	25
3000 ²	30
3200 ³	32
4000	40
5000	50
6000 ²	60

¹Universal Spare Trip Unit (Digit 3 = X)

²UL Only

³ANSI Only

Digit 3 EntelliGuard™ G Frame Ratings

Code	Interrupting Rating Tier ANSI/UL1066 Devices, LVPCB						Override No. 1	Override WI
	254V	580V	635V	1/2S Withstand	HSIOC			
S	65,000	65,000	50,000	50,000	50,000	49,000	53,500	
N	65,000	65,000	65,000	65,000	None	None	None	
H	85,000	85,000	65,000	65,000	65,000	63,700	69,500	
E	85,000	85,000	85,000	85,000	None	None	None	
M	100,000	100,000	100,000	85,000	85,000	83,800	90,950	
B	100,000	100,000	100,000	100,000	None	None	None	
L	150,000	150,000	100,000	100,000	100,000	98,000	107,000	

Code	Interrupting Rating Tier UL489 Devices ICCB						Override No. 1	Override WI
	240V	480V	600V	1/2S Withstand	HSIOC			
S	65,000	65,000	50,000	42,000	42,000	N/A	44,940	
N	65,000	65,000	65,000	42,000	42,000	N/A	44,940	
H	85,000	85,000	65,000	50,000	50,000	N/A	53,500	
M	100,000	100,000	100,000	65,000	65,000	N/A	69,550	
L	150,000	150,000	100,000	85,000	85,000	N/A	90,950	

Refer to GEH-4567 for other Circuit Breaker Types



Low Voltage Power & Insulated Case Circuit Breakers Section 8

Trip Units

Product Number Nomenclature System

Digit 6 and 7 Overcurrent Protection Package

Type	Over Current (OC) Protection Package	Code
EntelliGuard™ G ANSI/UL OC Protection	LSI (S, switchable) (I, switchable ANSI only)	L3
	LSIG (S, switchable) (I, switchable ANSI only)	L4
	LSIGA (S, switchable) (I, switchable ANSI only) (G, Alarm Only)	L5
	LSIC (S, switchable) (I, switchable ANSI only)	L6
	LSICA (S, switchable) (I, switchable ANSI only) (C, Alarm Only)	L7
	LSIGDA ¹ (S, G, A switchable) (I, switchable ANSI only)	L8
	LSIGCDA ¹ (S, G, C, A all switchable) (I, switchable ANSI only)	L9
	LSH (S, switchable) (I, switchable ANSI only)	LC
	LSHG (S, switchable) (I, switchable ANSI only)	LD
	LSHGA (S, switchable) (I, switchable ANSI only) (G, Alarm Only)	LE
	LSHC (S, switchable) (I, switchable ANSI only)	LF
	LSHCA (S, switchable) (I, switchable ANSI only) (C, Alarm Only)	LG
	LSHGDA ¹ (S, G, A switchable) (I, switchable ANSI only)	LH
	LSHGCA ¹ (S, G, C, A all switchable) (I, switchable ANSI only)	LK

¹Function Combination is NOT UL Listed

NOTES:

L = Long Time (L, I²T) + Fuse Settings (I⁴T) (Fuse settings are now standard on all EntelliGuard™ Trip Units)

S = Short Time (Switchable if Instantaneous (I) protection is enabled)

I = Standard Range Adjustable Instantaneous, (IIOC, 2x-15x)

H = Extended Range Adjustable Instantaneous, (IIOC, 2x-30x), Only for ANSI EntelliGuard™ G

G = Ground Fault Protection (GFP, 3-wire or 4-wire, internal summing) Trip and Alarm

C = External CT for ground fault detection (AKD20 application: input from external summing CTs, used for multiple source ground fault detection.

OEM Application: Zero Sequence Input of 1A = 100%)

D = Defeatable/Switchable Ground Fault, NOT UL Listed

A = Ground Fault, External Ground Fault, Alarm only

GA = Ground Fault Alarm Only

CA = External Ground Fault Alarm Only

GDA, GCDA = Ground Fault Trip and Ground Fault Alarm (all switchable, Not UL Listed)

Digit 8 Zone Selective Interlocking (ZSI)

Zone Selective Interlocking	Code
ZSI, Short time and GF; user selectable	Z
Z+IOC or HIOC ZSI; user selectable	T
Blank/none	X

ZSI selections require Secondary Disconnect Block B and 24Vdc control power.

NOTE: Option X is the only valid item when a Switch is selected in Digit 2.

Digit 9 Advanced Features and Communications

Advanced Features and Communications	Code
Reduced Energy Let-Through (RELT)	1
Modbus Protocol + RELT	2
Profibus Protocol + RELT	3
Monitoring + RELT, NO Communication	4
Monitoring + Relay Package + RELT	5
Monitoring + Data Acquisition, Modbus Protocol + RELT	6
Monitoring + Data Acquisition, Profibus Protocol + RELT	7
Monitoring + Data Acquisition + Relay Package, Modbus + RELT	8
Monitoring + Data Acquisition + Relay Package, Profibus + RELT	9
NONE	X

NOTES:

All Advanced Feature selections require Secondary Disconnect Block B and 24Vdc control power

RELT = Reduced Energy Let Through

Monitoring = Advanced Metering

Data Acquisition = Waveform Capture and Harmonic Analysis

Digit 10 Manual/Auto Trip Reset

Manual/Auto Trip Reset	Code
Manual Lockout	M
Auto Reset/Reclose	A
Auto/Manual Lockout (Selectable) ²	S ²
None (Defaults to Auto Reset/Reclose)	X

Note: When Bell Alarm with Lockout is selected on the EntelliGuard™ G Circuit Breaker, then Code M must be selected

X is only valid on GE Legacy Circuit Breakers and Conversion Kits

M is valid on EntelliGuard™ G Breakers when a Bell Alarm is selected

A is valid on EntelliGuard™ G Breakers when a Bell Alarm is not selected

²S is IEC Only

Digit 11 Factory or Field Installed

Manual/Auto Trip Reset	Code
Factory Installed Trip Unit (Original)	F
Replacement Trip Unit (shipped loose)	R



Low Voltage Power & Insulated Case Circuit Breakers Section 8 Trip Units

Product Number Nomenclature System

EntelliGuard™ TU Trip Unit for Power Break™, WavePro, AK/AKR, Conversion Kit Breakers Product Number Structure

Digit	G	B	2	1	6	L	4	X	6	X	R	X	X	X	X
	1 and 2		3	4 and 5		6 and 7		8	9	10	11	12	13	14	15
Trip Unit Form	Power Break™ II														
Frame Ratings	1600 Amp Frame														
Sensor Rating	1600														Future Use
Overcurrent Ground Fault Protection	LSIG (S, switchable) (I, switchable ANSI only)														
Zone Selective Interlocking	Blank														
Advanced Features and Communications	Monitoring + Data Acquisition, Modbus Protocol + RELT														
												Original / Replacement Trip Unit			
												F = Factory Installed (Original)			
												R = Replacement (Field Installed)			
												Manual / Auto Trip Reset			
												A, M, or S = EntelliGuard™ G only			
												X = for all others			

Digit 1 and 2 Trip Unit Form/Family

Circuit Breaker Type	Code
Power Break™ I (UL)	GA
Power Break™ II (UL)	GB
AK, AKR (ANSI)	GC
WP (ANSI)	GW
Mpact Low (IEC)	GL
Mpact 24-48V (IEC)	GH
Mpact 120-240V (IEC)	GQ
EntelliGuard™ G ACB (ANSI)	GG
EntelliGuard™ G ACB (UL)	GU
EntelliGuard™ G ACB (IEC)	GT
EntelliGuard™ G Universal Spare Trip	G1
Type A Conversion Kits (ANSI)	G2
EntelliGuard™ G Switch (IEC)	G3

Digit 4 and 5 Sensor Rating

Sensor Rating	Code
150	01
200	02
225	03
400	04
600	06
800	08
1000	10
1200	12
1600	16
2000	20
2500	25
3000	30
3200	32
4000	40
5000	50

Sensor must be equal to or less than Frame Rating

Digit 3 Legacy Frame Rating by Break Type

Code 3	Frame Rating	Breaker Type			
		Power Break™ I and II	WavePro	AKR	AK, Westinghouse, ITE, Allis Chalmers
A	225A				x
C	600A				x
0 ¹	800A (AKR30S)			x	
1	800A	x	x	x	x
2	1600A	x	x	x	x
3	2000A	x	x	x	x
4	2500A	x			
5	3000A	x		x	x
6	3200A		x	x	x
7	4000A	x	x	x	x
8	5000A		x		

10 is used for only AKR30S breakers



Low Voltage Power & Insulated Case Circuit Breakers Section 8 Trip Units

Product Number Nomenclature System

Digit 6 and 7 Overcurrent Protection Package

Type	Over Current (OC) Protection Package	Code	
Legacy ANSI/UL OC Protection	LSI (S, switchable) (I, switchable ANSI only)	L3	
	PB1 and PBII, AK, AKR, WavePro, Conv Kits	LSIG (S, switchable) (I, switchable ANSI only)	L4
	LSIGA (S, switchable) (I, switchable ANSI only) (G, Alarm Only)	L5	
	LSIGDA ¹ (S, G, A switchable) (I, switchable ANSI only)	L8	
	WavePro	LSI (S, switchable) (I, Non-switchable UL891 applications)	LP
	LSIG (S, switchable) (I, Non-switchable UL891 applications)	LQ	
	LSIGA (S, switchable) (I, Non-switchable UL891 applications) (G, Alarm Only)	LR	
	LSIGDA ¹ (S, G, A switchable) (I, Non-switchable UL891 applications)	LS	

¹Function Combination is NOT UL Listed

NOTES:

L = Long Time (L, I²T) + Fuse Settings (I⁴T) (Fuse settings are now standard on all IntelliGuard™ Trip Units)

S = Short Time (Switchable if Instantaneous (I) protection is enabled)

I = Standard Range Adjustable Instantaneous, (IOC, 2x-15x)

G = Ground Fault Protection (GFP, 3-wire or 4-wire, internal summing), Trip and Alarm

D = Defeatable/Switchable Ground Fault, NOT UL Listed

A = Ground Fault, Alarm only

GA = Ground Fault Alarm Only

GDA = Ground Fault Trip and Ground Fault Alarm (all switchable, Not UL Listed)

Digit 8 Zone Selective Interlocking (ZSI)

Zone Selective Interlocking	Code
ZSI, Short time and Ground Fault; user selectable	Z
ZSI, Instantaneous, Short Time, and Ground Fault; user selectable	T
Blank/None	X

All ZSI selections require a special harness (contact factory) and 24Vdc control power. ZSI Instantaneous (T), Power Break™ can only be used as a Feeder (ZSI-I out)

Digit 11 Original/Replacement Trip Unit

Original/Replacement	Code
Factory Installed (Original)	F
Replacement (Field Installed)	R

IntelliGuard™ TU

Circuit Break Type	Code 1 and 2
All Circuit Breakers	G

OC Protection Package	Code 6 and 7
LSI (S, switchable) (I, switchable ANSI only)	L3
LSIG (S, switchable) (I, switchable ANSI only)	L4
LSIGA (S, switchable) (I, switchable ANSI only)	L5
LSIGDA ² (S, G, A all switchable) (I, switchable ANSI only)	L8
JSI (S, switchable) (I, switchable ANSI only)	J3
JSIG (S, switchable) (I, switchable ANSI only)	J4
JSIGA (S, switchable) (I, switchable ANSI only)	J5
JSIGDA ¹ (S, G, A all switchable) (I, switchable ANSI only)	J8

Zone Selective Interlocking	Code 8
None Selected	X
ZSI, Short time and GF; user selectable	Z
Z + IOC or HSIOC ZSI; user selectable	T

Advanced Features and Communications	Code 9
None Selected	X
Reduced Energy Let-Through (RELT)	1
Modbus Protocol Only	2
Monitoring Only	4
Monitoring + Relay Package	5
Monitoring + Data Acquisition, Modbus Protocol	6
Monitoring + Data Acquisition + Relay Package, Modbus	8

¹Function Combination is NOT UL Listed

Digit 9 Advanced Features and Communications

Advanced Features and Communications	Digit 9	WP	PBII	AKR	Conv Kits
NONE (Ammeter)	X	x	x		x
Ammeter, Reduced Energy Let-Through (RELT)	1	x	x	x	x
Ammeter, Modbus Protocol + RELT	2		x		
Monitoring + Data Acquisition, Modbus Protocol + RELT	6	x	x	x	
Monitoring + Data Acquisition + Relay Package, Modbus + RELT	8	x	x	x	x
Ammeter, Modbus Protocol (Without RELT)	A		x		
Monitoring + Data Acquisition, Modbus Protocol (without RELT)	D	x	x	x	
Monitoring + Data Acquisition + Relay Package, Modbus (without RELT)	E	x	x	x	x

NOTES:

All Advanced Feature selections require 24Vdc control power

RELT = Reduced Energy Let Through (Harness may be required, contact factory)

Monitoring = Advanced Metering (Harness may be required, contact factory)

Data Acquisition = Waveform Capture and Harmonic Analysis

Options A, D, E are available when Ground Fault Alarm is selected

Digit 10 Manual/Auto Trip Reset

Manual/Auto Trip Reset	Code
Manual Reset (ANSI/UL IntelliGuard™ G Only)	M
Automatic Reset (ANSI/UL IntelliGuard™ G Only)	A
Automatic Reset (IEC IntelliGuard™ G Only)	S
Not Applicable (Power Break™, Power Break™ II, WavePro, AKR, Conv Kits)	X



Low Voltage Power & Insulated Case Circuit Breakers Section 8

Trip Units

Product Number Nomenclature System

Power+ Trip Unit and Power Break II Product Numbers

D2	20	LSI	T1	R¹
Trip Unit Type and Rating D2 = Power Break™ II Power+ Trip Unit: 2000 A sensor maximum D3 = Power Break™ II Power+ Trip Unit: 3000 A sensor maximum D4 = Power Break™ II Power+ Trip Unit: 4000 A sensor maximum				Replacement or New R = Replacement trip unit (Blank) = New
Current Sensor Rating 02 = 200 A 20 = 2000 A 04 = 400 A 25 = 2500 A 08 = 800 A 30 = 3000 A 10 = 1000 A 40 = 4000 A 16 = 1600 A				Trip unit options T1 = Target Module without ground fault target T2 = Target Module with ground fault target (Blank) = Factory Installed
				Auxiliary functions LI = Long-time and Instantaneous LSI = Long-time, Short-time, Instantaneous

¹Device Product Number requires an extender "R" for field installable kit version only.

NOTE: This information is provided only for use interpreting product numbers. It cannot be used to build product numbers.

Power+ Rating Plug Product Numbers

TR	10	C	800	GF
Trip Unit Type Rating TR = Trip unit rating plug All Power+, MicroVersaTrip™ Plus, and MicroVersaTrip™ PM rating plugs				Ground Fault Function Blank = No ground fault GF = Ground fault
Current Sensor Rating 02 = 200 A 20 = 2000 A 04 = 400 A 25 = 2500 A 08 = 800 A 30 = 3000 A 10 = 1000 A 40 = 4000 A 16 = 1600 A				Rating Plug Ampere Rating 100 = 100 A 800 = 800 A 150 = 150 A 1000 = 1000 A 200 = 200 A 1100 = 1100 A 225 = 225 A 1200 = 1200 A 250 = 250 A 1500 = 1500 A 300 = 300 A 1600 = 1600 A 400 = 400 A 2000 = 2000 A 450 = 450 A 2500 = 2500 A 500 = 500 A 3000 = 3000 A 600 = 600 A 3600 = 3600 A 700 = 700 A 4000 = 4000 A
Trip Unit Type C = Power+ trip unit rating plugs				

Power+ Target Module Product Numbers

TARGET00 = Blank insert for Target Module
 TARGET01 = Target Module without ground fault target
 TARGET02 = Target Module with ground fault target

NOTE: This information is provided only for use interpreting product numbers. It cannot be used to build product numbers.



Low Voltage Power & Insulated Case Circuit Breakers Section 8

Trip Units

Product Number Nomenclature System

Power+ Trip Unit and Power Break II Product Numbers

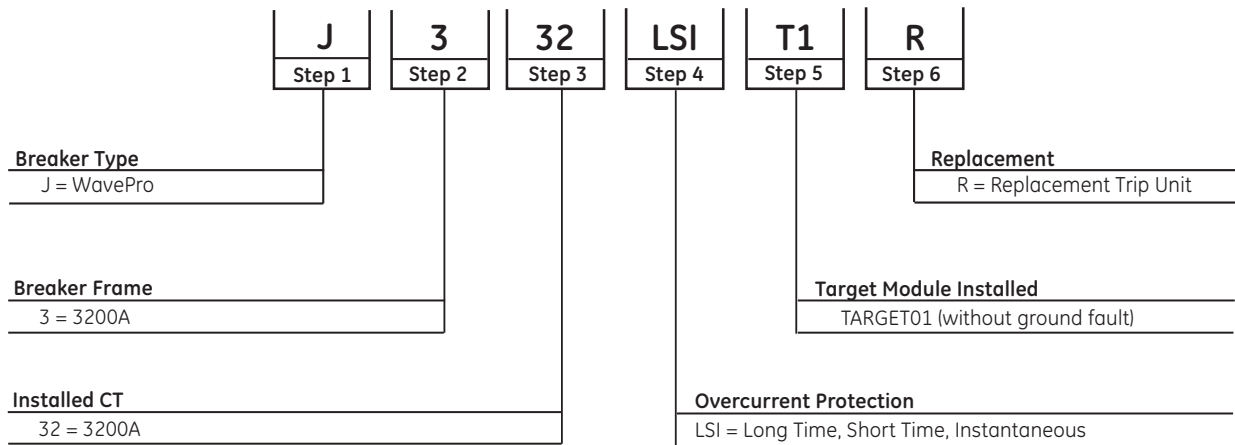

Power+ / WavePro

Step 1 Breaker Type

Breaker Type	Code
WavePro	J

Step 2 Breaker Frame

Breaker Frame (max CT)	Code
800A	8
1600A	1
2000A	2
3200A	3
4000A	4

Step 3 Installed CT

Installed CT	Code
150A	01
400A	04
800A	08
1600A	16
2000A	20
3200A	32
4000A	40

Step 4 Overcurrent Protection

Overcurrent Protection	Code
Long-Time (Standard)	L
Short-Time (Optional)	S
Instantaneous (Standard)	I

Step 5 Target Module Installed

Target Module Installed	Code
TARGET00 (Blank Insert)	(none)
TARGET01 (w/o ground fault)	T1
TARGET02 (with ground fault)	T2

Step 6 Replacement

Replacement	Code
Replacement Trip Unit	R



Low Voltage Power & Insulated Case Circuit Breakers Section 8 Trip Units

Product Number Nomenclature System

MicroVersaTrip™ Plus, MicroVersaTrip™ PM Trip Unit and Power Break II Product Number

B2	20	LSI	GZ1	PM	R ¹
Trip Unit Type and Rating B2 = Power Break™ II Enhanced MicroVersaTrip Plus™ or PM Trip Unit: 2000 A Sensor maximum B3 = Power Break™ II Enhanced MicroVersaTrip Plus™ or PM Trip Unit: 3000 A Sensor maximum B4 = Power Break™ II Enhanced MicroVersaTrip Plus™ or PM Trip Unit: 4000 A Sensor maximum				Remanufactured RM = Remanufactured Trip Unit RX = Exchanged Trip Unit	
Current Sensor Rating 02 = 200 A 20 = 2000 A 04 = 400 A 25 = 2500 A 08 = 800 A 30 = 3000 A 10 = 1000 A 40 = 4000 A 16 = 1600 A				Trip Unit Options Options for MicroVersaTrip™ PM trip units only. Must select one: P = Protective relays & communications M = Metering & communications PM = Protective relays, metering, & communications (Blank) = MicroVersaTrip™ Plus trip unit	
Auxiliary Functions LI = Long-time and instantaneous LSI = Long-time, short-time, instantaneous LSH = Long-time, short-time, high-range instantaneous				Ground Fault Functions G = Ground fault GD = Ground fault defeatable (not UL listed) GZ1 = Ground fault; zone selective interlocking for ground fault only GZ2 = Ground fault and short-time selective interlock GDZ2 = Ground fault defeatable (not UL listed); ground fault and short-time selective interlock (Blank) = None	

¹Device Product Number requires an extender "R" for field installable kit version only.
 NOTE: This information is provided only for use interpreting product numbers. It cannot be used to build product numbers.

Rating Plug Product Numbers (MicroVersaTrip™ Plus and PM)

TR	10	B	800
Device Type TR = Trip unit rating plug All MicroVersaTrip™ Plus and MicroVersaTrip™ PM rating plugs		Rating Plug Ampere Rating 100 = 100 A 1000 = 1000 A 150 = 150 A 1200 = 1200 A 200 = 200 A 1500 = 1500 A 225 = 225 A 1600 = 1600 A 300 = 300 A 2000 = 2000 A 400 = 400 A 2500 = 2500 A 500 = 500 A 3000 = 3000 A 600 = 600 A 3600 = 3600 A 700 = 700 A 4000 = 4000 A 800 = 800 A	
Current Sensor Rating 2 = 200 A 20 = 2000 A 4 = 400 A 25 = 2500 A 8 = 800 A 30 = 3000 A 10 = 1000 A 40 = 4000 A 16 = 1600 A		Trip Unit Type B = All Enhanced MicroVersaTrip™ Plus and MicroVersaTrip™ PM trip unit rating plugs	

NOTE: This information is provided only for use interpreting product numbers. It cannot be used to build product numbers.



Low Voltage Power & Insulated Case Circuit Breakers Section 8

Trip Units

Product Number Nomenclature System

MicroVersaTrip™ Plus, MicroVersaTrip™ PM Trip Unit and WavePro Product Number

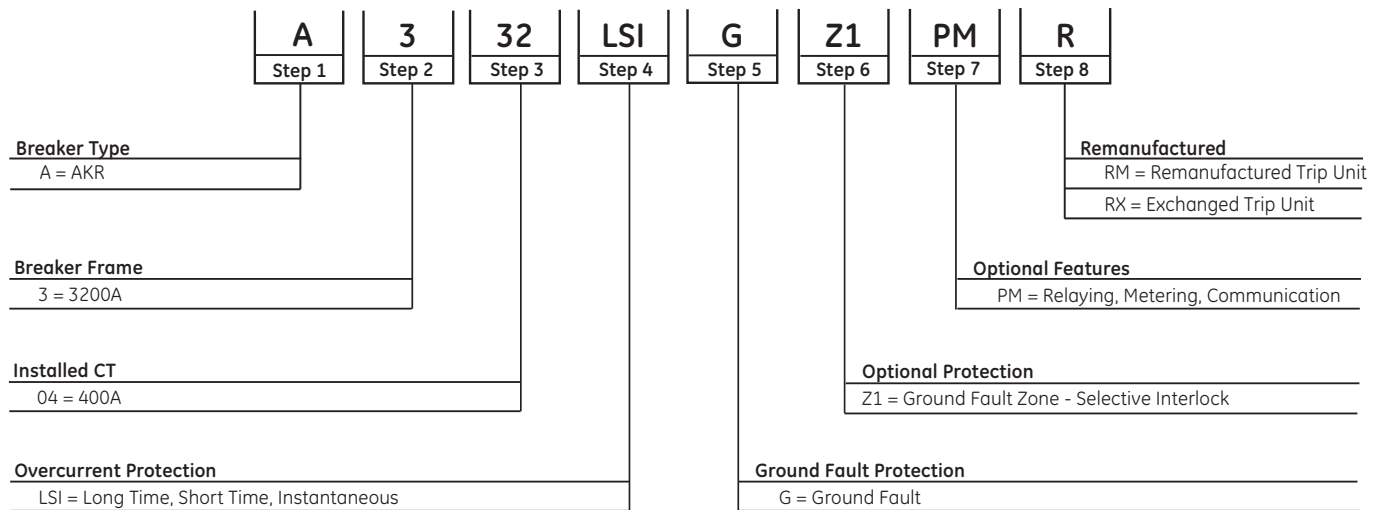

MVT PLUS/PM - WavePro

Step 1 Breaker Type

Breaker Type	Code
WavePro	K

Step 2 Breaker Frame

Frame Size	Code
800A	8
1600A	1
2000A	2
3200A	3
4000A	4
5000A	5

Step 3 Installed CT

Installed CT	Code
150A	01
400A	04
600A	06
800A	08
1600A	16
2000A	20
3200A	32
4000A	40
5000A	50

Step 4 Overcurrent Protection

Overcurrent Protection	Code
Long-Time (Standard)	L
Short-Time	S
Instantaneous	I

Step 5 Ground Fault Protection

Ground Fault Protection	Code
Ground Fault	G
Defeatable ground fault (user defeatable)	GD

Step 6 Replacement

Optional Protection	Code
Ground-Fault zone -selective interlock	Z1
Ground-Fault and short-time ZSI	Z2
Switchable instantaneous, short time and ground fault	X

Step 7 Optional Features

Optional Features	Code
Protective Relays and Communication	P
Metering and Communication	M

Step 8 Remanufactured

Remanufactured	Code
Remanufactured trip unit	RM
Exchanged trip unit	RX



Low Voltage Power & Insulated Case Circuit Breakers Section 8 Trip Units

Product Number Nomenclature System

MicroVersaTrip™ Plus, MicroVersaTrip™ PM Trip Unit and Power Break Product Number

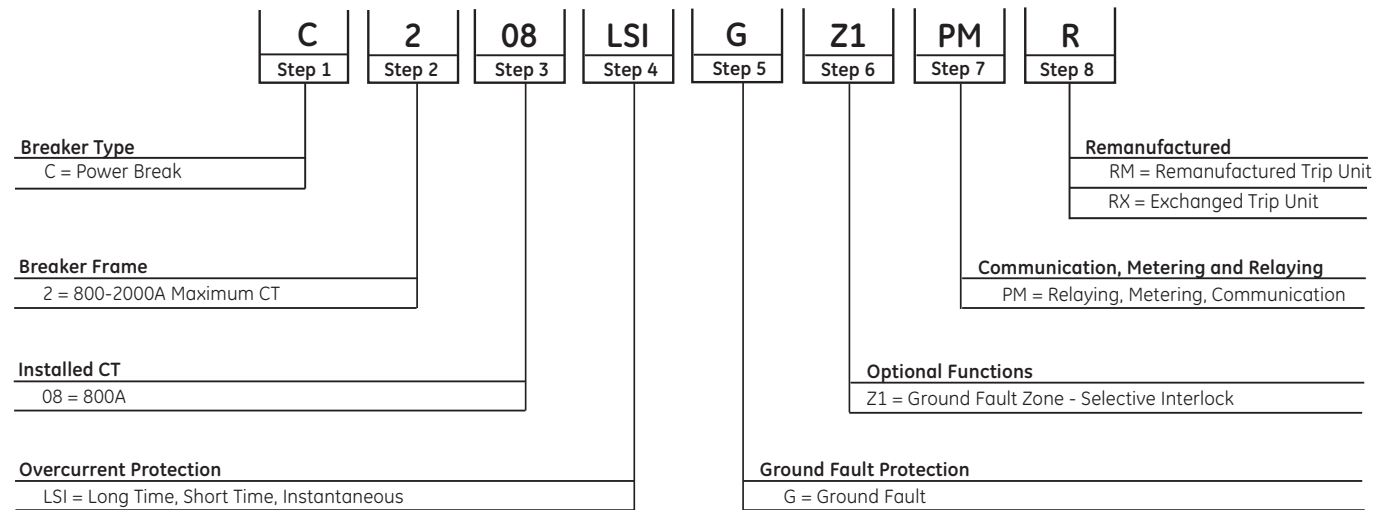

MVT PLUS/PM - PowerBreak

Step 1 Breaker Type

Breaker Type	Code
Power Break	C

Step 5 Ground Fault Protection

Ground Fault Protection	Code
Ground Fault	G
Defeatable ground fault (not UL Listed)	GD

Step 2 Breaker Frame

Frame Size (max CT)	Code
800-2000A	2
3000A	3
4000A	4

Step 6 Optional Functions

Optional Functions	Code
Ground-Fault zone -selective interlock	Z1
Ground-Fault and short-time ZSI	Z2

Step 3 Installed CT

Installed CT	Code
200A	02
400A	04
600A	06
800A	08
1000A	10
1600A	16
2000A	20
2500A	25
3000A	30
4000A	40

Step 7 Communication, Metering and Relaying

Communication, Metering and Relaying	Code
Relaying and Communication	P
Metering and Communication	M

Step 8 Remanufactured

Remanufactured	Code
Remanufactured trip unit	RM
Exchanged trip unit	RX

Step 4 Overcurrent Protection

Overcurrent Protection	Code
Long-Time (Standard)	L
Short-Time	S
High Instantaneous	H
Instantaneous	I



Low Voltage Power & Insulated Case Circuit Breakers Section 8

Trip Units

Product Number Nomenclature System

MicroVersaTrip™ Plus, MicroVersaTrip™ PM Trip Unit and AKR Product Number

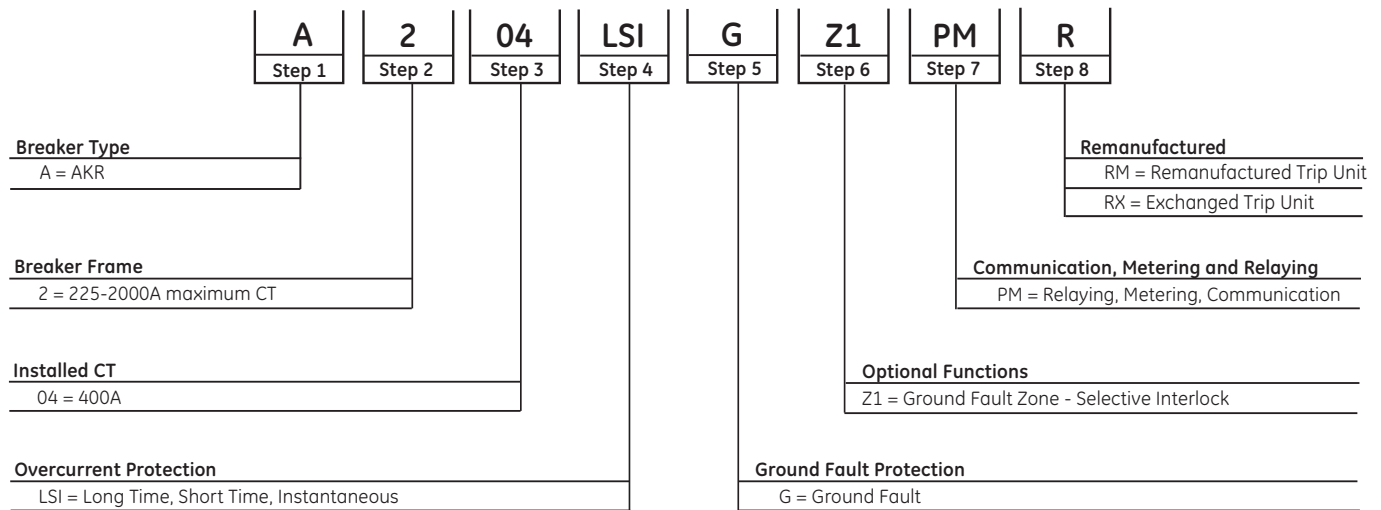

MVT PLUS/PM - AKR

Step 1 Breaker Type

Breaker Type	Code
Power Break	C

Step 2 Breaker Frame

Breaker Frame (max CT)	Code
225-2000A	2
3200A	3
4000A	4

Step 3 Installed CT

Installed CT	Code
150A	01
225A	03
400A	04
600A	06
800A	08
1600A	16
2000A	20
3000A	30
3200A	32
4000A	40

Step 4 Overcurrent Protection

Overcurrent Protection	Code
Long-Time (standard)	L
Short-Time	S
High Instantaneous	H
Instantaneous	I
Fixed High Instantaneous	K

Step 5 Ground Fault Protection

Ground Fault Protection	Code
Ground Fault	G
Defeatable ground fault (not UL Listed)	GD
W Curve	W

Step 6 Optional Functions

Optional Functions	Code
Ground-Fault zone - selective interlock	Z1
Ground-Fault and short-time ZSI	Z2
Switchable instantaneous short time and ground fault	X

Step 7 Communication, Metering and Relaying

Communication, Metering and Relaying	Code
Relaying and Communication	P
Metering and Communication	M

Step 8 Remanufactured

Remanufactured	Code
Remanufactured trip unit	RM
Exchanged trip unit	RX



GE offers a complete line of trip unit upgrade kits for low voltage power circuit breakers manufactured by GE, as well as by Westinghouse, I-T-E, and Allis-Chalmers. These conversion kits contain everything necessary to convert an old-style electro-mechanical or solid-state trip unit to today's latest electronic, digital technology—including the addition of metering, protective relay, waveform capture, RELT, and communication functions. All conversion kits designed by GE are tested to ANSI C37.59 standards for each breaker type so customers have the assurance of safe, reliable operation.

Features and Benefits—All Kits

- Kit includes everything needed in one compact package
- Full-range of interchangeable rating plugs
- Trip targets for quick identification of overload, short circuit, and ground fault trips
- Sealable, see-through cover to prevent unauthorized access to trip unit settings
- Portable Trip Unit Test Kits; GTUTK20 and TVRMS2
- Eliminate costly downtime due to nuisance tripping
- Improved power system coordination and protection
- Extend life and function of existing breakers and low voltage equipment

EntelliGuard™ TU Conversion Kits

- True RMS sensing with a sampling rate of 48 samples per cycle with the ability to Waveform capture 4 cycles prior and 4 cycles after an event
- Long Time, Short Time, and Instantaneous Standard on all trip units. S and I switchable on ANSI breakers
- Large backlit LCD screen, view all currents on one screen
- Trip settings and trip target information stored in non-volatile memory
- On-board lithium battery (field replaceable) for cold set-up and reading trip targets
- Status and Event Log, view the last 10 events
- Health Status LED and Thermal Memory
- Comm port for interface with set-up software and to download Waveform
- Optional metering, relaying, communications, ZSI - I, ground fault (trip & alarm), and fused shaped curves
- Plug and Play with previous generation of RMS9, EPIC, MVT and Enhanced MVT Trip Units

ProTrip™ Conversion Kits

- Cost-effective upgrade with standard adjustable long time, short time, instantaneous, and defeatable ground fault functions
- Simple-to-use rotary switches for selecting the trip unit pickup and delay settings
- True RMS sensing with sampling rate of 48 times per cycle per phase - accurate waveform measurements through the 11th harmonic
- Standard target module with individual LEDs for overload pickup, overload trip, short circuit trip, ground fault trip, and target module battery monitor

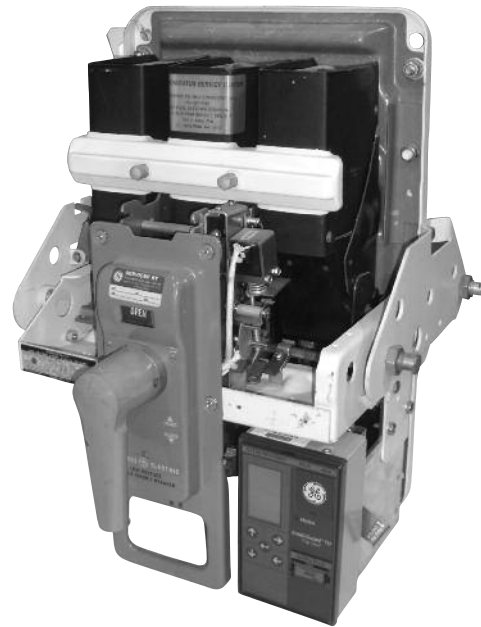

AK-25 Breaker with EntelliGuard™ TU Trip Unit

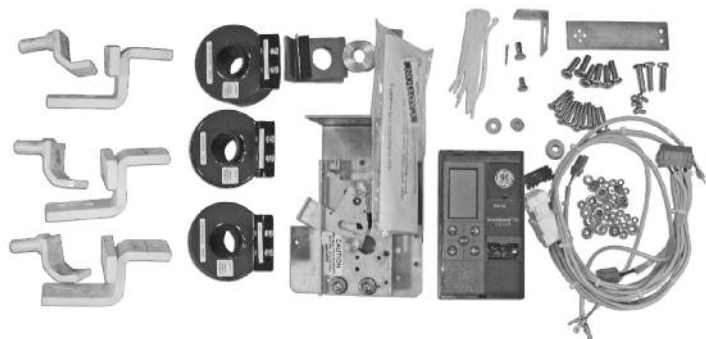

EntelliGuard™ TU Conversion Kits

Everything You Need in One Package

ProTrip™ and EntelliGuard™ TU conversion kits for the breakers listed in the following pages are shipped complete with detailed installation instructions and everything needed for fast and easy trip unit conversions.

- Digital solid-state trip with quick disconnect
- Direct-acting flux shift trip actuator with automatic reset
- Epoxy encapsulated high-accuracy current sensors
- Interchangeable rating plug (order separately)
- Specially designed mounting hardware and wire harnesses for each breaker frame



EntelliGuard™ TU Conversion Kits— Upgrade your low-voltage equipment with electronic trip unit technology.

Normal wear and tear of aging electro-mechanical trip devices on low-voltage circuit breakers increases susceptibility to loss of calibration that can subsequently jeopardize electrical power system coordination, protection and reliability.

GE has channeled its decades of circuit breaker trip system experience into the development of the EntelliGuard™ TU Trip Unit. The EntelliGuard™ TU builds on the past trip units by incorporating advance algorithms that enable Arc Flash protection and Selectivity at the same time.

ANSI C37.59 design verification tested to ensure safe, reliable operation, these kits are designed to extend the life of your mechanically sound breaker and...

- Eliminate costly downtime due to nuisance tripping. Improves on past trip units with a Waveform Recognition Instantaneous Algorithm
- Improve electrical power system coordination and protection
- Permit easy upgrades to communicating Power Management Control Systems (PMCS), open Modbus RTU protocol
- Enable the implementation of RELT and Zone Selective Interlock Instantaneous to reduce Arc Flash Energy Levels.

Standard Features

- Flexible Time Current Settings
- I²T Long Time, Long Time Delay
- Short Time, Short Time Delay, 3 Short Time I²T Slopes
- Waveform Recognition Instantaneous
- Ammeter
- Large Backlit LCD Screen¹
- Date and Time¹
- Breaker Status Indication
- Universal Rating Plugs
- Status and Event Log (10 Events)
- LED Health Status Indicator¹
- Set-up Software
- I/O – 1 Input and 1 Output¹
- Thermal Memory, Battery Back-up
- Common Interface across all versions

Optional

- Internal/External Ground Fault Trip or Alarm with 4 curves to select from (I²T, I⁴T, SGF, Definite Time Slope)¹
- Switchable Ground Fault Trip / Alarm (not UL Listed)
- Fused Long Time Curves (I⁴T)
- Modbus Open RTU Communications¹
- Waveform Capture – Enables Harmonic analysis
- Full-function Metering¹
- Protective Relaying¹
- Zone Selective Interlock – GF, S, I¹
- RELT – Reduce Energy Let Through¹
- RELT and Ground Fault Alarm Harness Kits
- Test Set GTUTK20



EntelliGuard™ TU Trip Unit

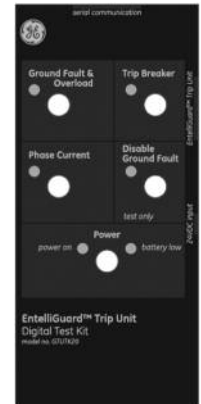

Test Kit – GTUTK20

Arc Flash and Selectivity at the same time

The EntelliGuard™ TU Trip Unit offers optimum circuit protection and optimum system reliability simultaneously with little or no compromise to either of these critical functions. Reliability and arc flash protection, in one package, at the same time, all the time.

Algorithms enabling arc flash protection and selectivity

- RELT – Reduced Energy Let Through
- Instantaneous Zone Selective Interlocking – (I-ZSI)
- Waveform Recognition Instantaneous – Coordinate with Current Limiting Devices and reduces Nuisance Trips
- Flexible Time Current Curves – Create the shape you need

Reliability – Health Status

- Non-volatile memory with continuous self-testing microprocessor
- Health Status LED indicates Normal Operation, Errors, Pick-up, Trip
- External Power Not Required with Long Life Lithium Battery
- Positive setpoint recognition, values flash until saved

Plug and Play

- Same Form, Fit, Function as the popular MicroVersaTrip™ Trip Unit. Easily upgrade an existing converted breaker¹

Optional Full-function metering including¹

- current (Amps, kAmps)
- voltage (Ph-Ph, Ph-N)
- energy (kWh, MWh, GWh)
- real power (kW, MW)
- total power (kVA, MVA)
- frequency (Hz)
- demand (avg. kW, MW) and peak demand

Optional protective relaying functions include¹

- undervoltage
- overvoltage
- voltage unbalance
- current unbalance
- power reversal
- power direction setup

¹Note: Some options require 24Vdc, additional hardware to enable Metering, Relaying, RELT, ZSI, Modbus to be added to the Breaker, Equipment Cubicle, and Equipment Sections.



Low Voltage Power & Insulated Case Circuit Breakers Trip Unit Conversion Kits for I-T-E, Westinghouse, Allis-Chalmers Circuit Breakers

Section 8

MicroVersaTrip™ PM Conversion Kits— Power Management Made Easy

The MicroVersaTrip™ PM trip unit's standard communication port opens a new world of information. When connected to a GE Power Management system, it gives you the power to increase productivity and reduce costs, while meeting all your electrical system monitoring needs.

The POWER LEADER™ Modbus Concentrator can be connected to MicroVersaTrip™ PM trip units, allowing communication with the GE Power Management Control System (PMCS) software. With PMCS, you'll see how easy it is to:

- View custom metering screens and CAD drawings of our system
- Analyze energy consumption and power factor trends to minimize utility demand and PF charges or provide cost allocations
- Collect precise sequence of event and alarm information to speed diagnosis and minimize downtime
- Utilize alarm and event logs to assist with maintenance interval planning
- Analyze system harmonics (with data from the POWER LEADER™ family of meters)
- Use the POWER LEADER™ Modbus Concentrator to communicate with MicroVersaTrip™ PM trip units on Spectra Series molded case circuit breakers, Power Break II insulated case circuit breakers, and AKR/WavePro power circuit breakers (refer to BuyLog™ Section 22 for network architecture)
- Communicate with Modbus RTU-supported electronic meters and relays

Additional Features

Full-function metering including

- current (Amps, kAmps)
- voltage (Ph-Ph, Ph-N)
- energy (kWh, MWh, GWh)
- real power (kW, MW)
- total power (kVA, MVA)
- frequency (Hz)
- demand (avg. kW, MW) and peak demand

Optional protective relaying functions include

- undervoltage
- overvoltage
- voltage unbalance
- current unbalance
- power reversal
- power direction setup



Refer to BuyLog™ Section 22 for additional Power Management components not supplied with the MicroVersaTrip™ PM conversion kits (voltage transformers, voltage conditioners, 24 Vdc power supplies, Modbus Concentrator, interconnection cables, and PMCS software)

Reference Publications

GE MVT Plus and PM Conversion Kits	DET-066
I-T-E MVT Plus and PM Conversion Kits	DET-067
Westinghouse MVT Plus and PM Conversion Kits	DET-093
Allis-Chalmers MVT Plus and PM Conversion Kits	DET-226
GE ProTrip™ Conversion Kits	DET-228
I-T-E ProTrip™ Conversion Kits	DET-229
Westinghouse ProTrip™ Conversion Kits	DET-230
Allis-Chalmers ProTrip™ Conversion Kits	DET-231



Overview and Features

Overview

GE is extending the lifecycle of this important component by offering a remanufactured MVT solution. As of January 2012, GE will no longer manufacture its MicroVersaTrip Plus™ and MicroVersaTrip PM™ trip units.

GE's MVT Trip Units were manufactured from 1994 through 2011. GE's latest Trip Unit model is the EntelliGuard TU, offering improved selectivity and reliability. However, for those customers not yet ready to upgrade, GE offers Remanufactured MVT Trip Units to extend the lifecycle of this product for an additional 5 or more years.

GE is committed to our customers through lifecycle support of legacy equipment with quality services and solutions meeting original specifications.

GE Remanufactured MVT Trip Units meet OEM specifications, including new electronic boards and factory acceptance testing.

Key Features

- Original GE parts
- Complete replacement of all electronic circuit boards
- Fully tested to original specifications
- GE warranty
- Standard next-day shipping; same-day shipping available upon request
- POWER LEADER™ communications network supported

Benefits

Longer life

GE Remanufactured MVT Trip Units allow you to extend the lifecycle of your trip unit with service and remanufactured products from GE.

Identical fit

GE Remanufactured MVT Trip Units are a plug-and-play unit identical to your original unit in form, fit and function. Customers are responsible for configuring the Remanufactured MVT Trip Units to their specific system protection needs.

GE quality

GE Remanufactured MVT Trip Units have new electronic boards and are fully tested to original manufacturer's standards.

GE provides proven repair techniques and service from the original manufacturer for your trip unit.



MicroVersaTrip Plus™



MicroVersaTrip PM™



For more information, contact your local GE office, call 1-888-GE4-SERV or 540-378-3280, or visit www.geindustrial.com/services



Low Voltage Power & Insulated Case Circuit Breakers Section 8

ProTrip™ Trip Unit Conversion Kit Selection Guide

For GE Circuit Breakers

Product Number Structure

PK115		D	3	F	01	08
Breaker						Trip Functions LSIGX- 08
AK-1-15	PK115					
AK-15	PKO15 ¹					
AK-1-25	PK125					
AK-25	PKO25 ¹					
AKU-25						
AK-1-50	PK150					
AK-50						
AKU-50 ²						
AKT-50	PKO50 ¹					
AKS-50						
AKSU-50 ²						
AKST-50						
AK-75 ³	PKO75 ³					
AK-100 ³	PKO10 ³					
Model						Trip Unit Functions
Generation-D						LSIGX- Long Time, Short Time/INST. and Switchable Ground Fault (off) Not Approved for a UL Listed Breaker
Wiring						
3 Wire-3						
4 Wire-4						
Sensor Type						
Fixed CTs-F						
					Sensor Rating	
					150A- 01	
					225A- 02	
					600A- 06	
					800A- 08	
					1600A- 16	
					2000A- 20	
					3000A- 30	
					4000A- 40	
						Sensor Rating Selection
						Frame Breaker Product Numbers Sensors
					225 AK-1-15, AK-15	150A, 225A
					600 AK-1-25, AK-25, AKU-25	150A, 225A, 600A
					1600 AK-1-50, AK-50, AKU-50, AKS-50, AKSU-50	800A, 1600A
					2000 AKT-50, AKST-50	2000A
					3000 AK-75	3000A
					4000 AK-100	4000A

¹For converting AK-2 version breakers and newer, not applicable for AK-1 or AKR

²Breakers equipped with older style open fuse lockout devices (OFLO), must be retrofitted with newer style OFLO device prior to conversion process.

Order replacement OFLO kits as follows: AKU-50 - order OFLO kit #121C287OG2, AK-75 - order OFLO kit #121C287OG3, AK-100 - order OFLO kit #121C287OG4

³Contact the factory for stationary breaker applications

ProTrip™ Conversion Kits

Frame Size (Amps)	Breaker Model	Wiring	Sensor Rating	Product Number
225	AK-1-15	3 Wire	150A	PK115D3F0108
225	AK-1-15	3 Wire	225A	PK115D3F0208
225	AK-1-15	4 Wire	150A	PK115D4F0108
225	AK-1-15	4 Wire	225A	PK115D4F0208
225	AK-15	3 Wire	150A	PKO15D3F0108
225	AK-15	3 Wire	225A	PKO15D3F0208
225	AK-15	4 Wire	150A	PKO15D4F0108
225	AK-15	4 Wire	225A	PKO15D4F0208
600	AK-1-25	3 Wire	150A	PK125D3F0108
600	AK-1-25	3 Wire	225A	PK125D3F0208
600	AK-1-25	3 Wire	600A	PK125D3F0608
600	AK-1-25	4 Wire	150A	PK125D4F0108
600	AK-1-25	4 Wire	225A	PK125D4F0208
600	AK-1-25	4 Wire	600A	PK125D4F0608
600	AK-25, AKU-25	3 Wire	150A	PKO25D3F0108
600	AK-25, AKU-25	3 Wire	225A	PKO25D3F0208
600	AK-25, AKU-25	3 Wire	600A	PKO25D3F0608
600	AK-25, AKU-25	4 Wire	150A	PKO25D4F0108
600	AK-25, AKU-25	4 Wire	225A	PKO25D4F0208
600	AK-25, AKU-25	4 Wire	600A	PKO25D4F0608
1600	AK-1-50	3 Wire	800A	PK150D3F0808
1600	AK-1-50	3 Wire	1600A	PK150D3F1608
1600	AK-1-50	4 Wire	800A	PK150D4F0808
1600	AK-1-50	4 Wire	1600A	PK150D4F1608
1600	AK-50, AKU-50, AKT-50, AKS-50, AKSU-50, AKST-50	3 Wire	800A	PKO50D3F0808
1600	AK-50, AKU-50, AKT-50, AKS-50, AKSU-50, AKST-50	3 Wire	1600A	PKO50D3F1608
1600	AK-50, AKU-50, AKT-50, AKS-50, AKSU-50, AKST-50	3 Wire	2000A	PKO50D3F2008
1600	AK-50, AKU-50, AKT-50, AKS-50, AKSU-50, AKST-50	4 Wire	800A	PKO50D4F0808
1600	AK-50, AKU-50, AKT-50, AKS-50, AKSU-50, AKST-50	4 Wire	1600A	PKO50D4F1608
1600	AK-50, AKU-50, AKT-50, AKS-50, AKSU-50, AKST-50	4 Wire	2000A	PKO50D4F2008
3000	AK-75	3 Wire	3000A	PKO75D3F3008
3000	AK-75	4 Wire	3000A	PKO75D4F3008
4000	AK-100	3 Wire	4000A	PKO10D3F4008
4000	AK-100	4 Wire	4000A	PKO10D4F4008

Conversion kits come standard with a rating plug that matches the current sensor. For rating plugs with different values, order separately. See page 8-74.



Low Voltage Power & Insulated Case Circuit Breakers Section 8

ProTrip™ Trip Unit Conversion Kit Selection Guide

For *I-T-E Circuit Breakers

Product Number Structure

		PIK22	D	3	F	02	08		
Breaker								Trip Functions	
K225	PIK22¹							LSIGX- 08	
K600	PIK60¹							Trip Unit Functions LSIGX- Long Time, Short Time/INST. and Switchable Ground Fault (off) Not Approved for a UL Listed Breaker	
KDON600									
K800	PIK80¹								
KDON800									
K1600 (black)	PIK1B¹								
KDON1600 (black)									
K1600 (red)	PIK16^{1,2}								
KDON1600 (red)	PIKN^{1,3}								
Model									
Generation-D									
Wiring									
3 Wire-3									
4 Wire-4									
Sensor Type									
Fixed CTs-F									

Sensor Rating		
150A-	01	
225A-	02	
400A-	04	
600A-	06	
800A-	08	
1600A-	16	

Sensor Rating Selection		
Frame	Breaker Product Numbers	Sensors
225	K225	150A, 225A
600	K600, KDON600	150A, 225A, 600A
800	K800, KDON800	150A, 400A, 800A
1600	K1600 (black), KDON1600 (black), K1600 (red), KDON1600 (red)	800A, 1600A

¹ Applicable to breakers originally equipped with either electro-mechanical trip devices or with solid state trip devices ("S" version breakers).

² Only applicable to breakers originally equipped with rectangular shaped primary disconnect assemblies.

³ Only applicable to breakers originally equipped with circular shaped primary disconnect assemblies.

ProTrip™ Conversion Kits

Frame Size (Amps)	Breaker Model	Wiring	Sensor Rating	Product Number
225	K225	3 Wire	150A	PIK22D3F0108
225	K225	3 Wire	225A	PIK22D3F0208
225	K225	4 Wire	150A	PIK22D4F0108
225	K225	4 Wire	225A	PIK22D4F0208
600	K600, KDON600	3 Wire	150A	PIK60D3F0108
600	K600, KDON600	3 Wire	225A	PIK60D3F0208
600	K600, KDON600	3 Wire	600A	PIK60D3F0608
600	K600, KDON600	4 Wire	150A	PIK60D4F0108
600	K600, KDON600	4 Wire	225A	PIK60D4F0208
600	K600, KDON600	4 Wire	600A	PIK60D4F0608
800	K800, KDON800	3 Wire	150A	PIK80D3F0108
800	K800, KDON800	3 Wire	400A	PIK80D3F0408
800	K800, KDON800	3 Wire	800A	PIK80D3F0808
800	K800, KDON800	4 Wire	150A	PIK80D4F0108
800	K800, KDON800	4 Wire	400A	PIK80D4F0408
800	K800, KDON800	4 Wire	800A	PIK80D4F0808
1600	K1600 (black), KDON1600 (black)	3 Wire	800A	PIK1BD3F0808
1600	K1600 (black), KDON1600 (black)	3 Wire	1600A	PIK1BD3F1608
1600	K1600 (black), KDON1600 (black)	4 Wire	800A	PIK1BD4F0808
1600	K1600 (black), KDON1600 (black)	4 Wire	1600A	PIK1BD4F1608
1600	K1600 (red)	3 Wire	800A	PIK16D3F0808
1600	K1600 (red)	3 Wire	1600A	PIK16D3F1608
1600	K1600 (red)	4 Wire	800A	PIK16D4F0808
1600	K1600 (red)	4 Wire	1600A	PIK16D4F1608
1600	KDON1600 (red)	3 Wire	800A	PIKN1D3F0808
1600	KDON1600 (red)	3 Wire	1600A	PIKN1D3F1608
1600	KDON1600 (red)	4 Wire	800A	PIKN1D4F0808
1600	KDON1600 (red)	4 Wire	1600A	PIKN1D4F1608

Conversion kits come standard with a rating plug that matches the current sensor. For rating plugs with different values, order separately. See page 8-74.

*I-T-E is a registered trademark of Siemens Energy and Automation, Inc.



Low Voltage Power & Insulated Case Circuit Breakers Section 8

ProTrip™ Trip Unit Conversion Kit Selection Guide

For *Allis-Chalmers Circuit Breakers

Product Number Structure

PSL6B		D	3	F	02	08
Breaker						Trip Functions
LA-600 (blue)	PSL6B					LSIGX- 08
LAF-600 (blue)						
LA-600 (gold)	PSL6G					Trip Unit Functions
LAF-600 (gold)						
LA-800 (gold)	PSL80					LSIGX- Long Time, Short Time/INST. and Switchable Ground Fault (off)
LAF-800 (gold)						
LA-1600 (blue)	PSL1B					Not Approved for a UL Listed Breaker
LAF-1600 (blue)						
LA-1600 (gold)	PSL1G					
LAF-1600 (gold)						
Model						
Generation-D						
Wiring						
3 Wire-3						
4 Wire-4						
Sensor Type						
Fixed CTs-F						

Sensor Rating	
150A-	01
225A-	02
400A-	04
600A-	06
800A-	08
1600A-	16

Sensor Rating Selection		
Frame	Breaker Product Numbers	Sensors
600	LA-600 (blue), LAF-600 (blue)	150A, 225A, 600A
	LA-600 (gold), LAF-600 (gold)	
800	LA-800 (gold), LAF-800 (gold)	150A, 400A, 800A
1600	LA-1600 (blue), LAF-1600 (blue)	800A, 1600A
	LA-1600 (gold), LAF-1600 (gold)	

ProTrip™ Conversion Kits

Frame Size (Amps)	Breaker Model	Wiring	Sensor Rating	Product Number
600	LA-600 (blue), LAF-600 (blue)	3 Wire	150A	PSL6BD3F0108
600	LA-600 (blue), LAF-600 (blue)	3 Wire	225A	PSL6BD3F0208
600	LA-600 (blue), LAF-600 (blue)	3 Wire	600A	PSL6BD3F0608
600	LA-600 (blue), LAF-600 (blue)	4 Wire	150A	PSL6BD4F0108
600	LA-600 (blue), LAF-600 (blue)	4 Wire	225A	PSL6BD4F0208
600	LA-600 (blue), LAF-600 (blue)	4 Wire	600A	PSL6BD4F0608
600	LA-600 (gold), LAF-600 (gold)	3 Wire	150A	PSL6GD3F0108
600	LA-600 (gold), LAF-600 (gold)	3 Wire	225A	PSL6GD3F0208
600	LA-600 (gold), LAF-600 (gold)	3 Wire	600A	PSL6GD3F0608
600	LA-600 (gold), LAF-600 (gold)	4 Wire	150A	PSL6GD4F0108
600	LA-600 (gold), LAF-600 (gold)	4 Wire	225A	PSL6GD4F0208
600	LA-600 (gold), LAF-600 (gold)	4 Wire	600A	PSL6GD4F0608
800	LA-800 (gold)	3 Wire	150A	PSL80D3F0108
800	LA-800 (gold)	3 Wire	400A	PSL80D3F0408
800	LA-800 (gold)	3 Wire	800A	PSL80D3F0808
800	LA-800 (gold)	4 Wire	150A	PSL80D4F0108
800	LA-800 (gold)	4 Wire	400A	PSL80D4F0408
800	LA-800 (gold)	4 Wire	800A	PSL80D4F0808
1600	LA-1600 (blue), LAF-1600 (blue)	3 Wire	800A	PSL1BD3F0808
1600	LA-1600 (blue), LAF-1600 (blue)	3 Wire	1600A	PSL1BD3F1608
1600	LA-1600 (blue), LAF-1600 (blue)	4 Wire	800A	PSL1BD4F0808
1600	LA-1600 (blue), LAF-1600 (blue)	4 Wire	1600A	PSL1BD4F1608
1600	LA-1600 (gold), LAF-1600 (gold)	3 Wire	800A	PSL1GD3F0808
1600	LA-1600 (gold), LAF-1600 (gold)	3 Wire	1600A	PSL1GD3F1608
1600	LA-1600 (gold), LAF-1600 (gold)	4 Wire	800A	PSL1GD4F0808
1600	LA-1600 (gold), LAF-1600 (gold)	4 Wire	1600A	PSL1GD4F1608

Conversion kits come standard with a rating plug that matches the current sensor. For rating plugs with different values, order separately. See page 8-74.

*Allis-Chalmers is a trademark of Allis-Chalmers Manufacturing Company Corporation.



Low Voltage Power & Insulated Case Circuit Breakers Section 8

ProTrip™ Trip Unit Conversion Kit Selection Guide

For *Westinghouse Circuit Breakers

Product Number Structure

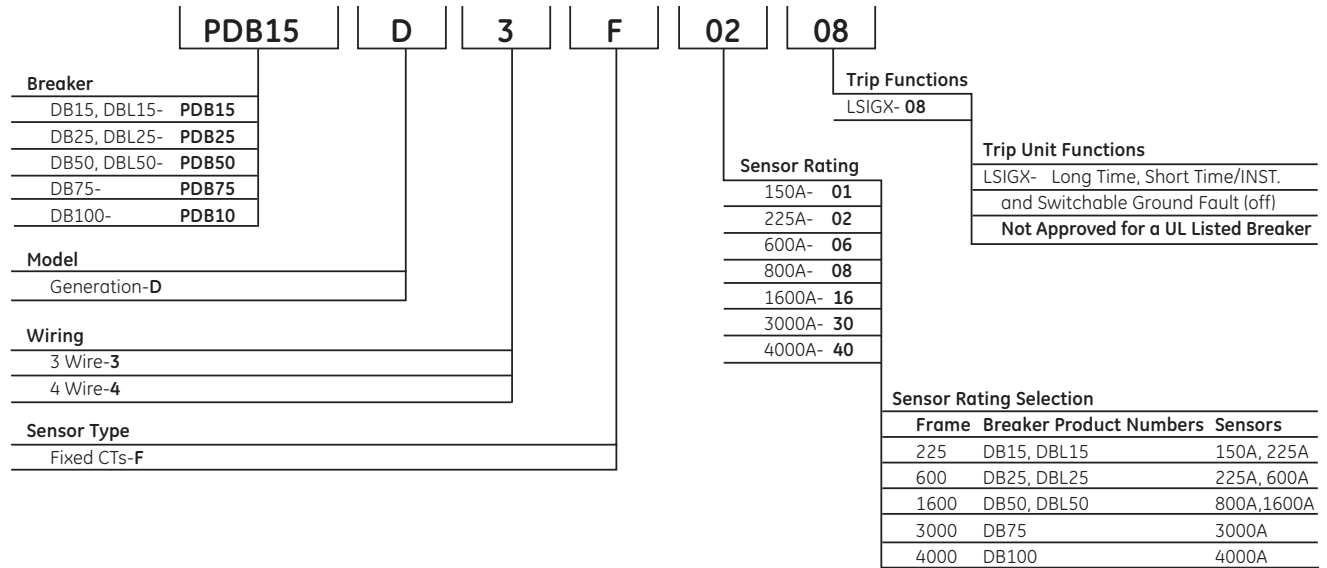

ProTrip™ Conversion Kits

Frame Size (Amps)	Breaker Model	Wiring	Sensor Rating	Product Number
225	DB15, DBL15	3 Wire	150A	PDB15D3F0108
225	DB15, DBL15	3 Wire	225A	PDB15D3F0208
225	DB15, DBL15	4 Wire	150A	PDB15D4F0108
225	DB15, DBL15	4 Wire	225A	PDB15D4F0208
600	DB25, DBL25	3 Wire	150A	PDB25D3F0108
600	DB25, DBL25	3 Wire	225A	PDB25D3F0208
600	DB25, DBL25	3 Wire	600A	PDB25D3F0608
600	DB25, DBL25	4 Wire	150A	PDB25D4F0108
600	DB25, DBL25	4 Wire	225A	PDB25D4F0208
600	DB25, DBL25	4 Wire	600A	PDB25D4F0608
1600	DB50, DBL50	3 Wire	800A	PDB50D3F0808
1600	DB50, DBL50	3 Wire	1600A	PDB50D3F1608
1600	DB50, DBL50	4 Wire	800A	PDB50D4F0808
1600	DB50, DBL50	4 Wire	1600A	PDB50D4F1608
3000	DB75	3 Wire	3000A	PDB75D3F3008
3000	DB75	4 Wire	3000A	PDB75D4F3008
4000	DB100	3 Wire	4000A	PDB10D3F4008
4000	DB100	4 Wire	4000A	PDB10D4F4008

Conversion kits come standard with a rating plug that matches the current sensor. For rating plugs with different values, order separately. See page 8-74.

*Westinghouse is a trademark of Westinghouse Electric Corporation.



Low Voltage Power & Insulated Case Circuit Breakers Section 8

ProTrip™ Rating Plugs

ProTrip™ conversion kits come standard with a rating plug that matches the current sensor. For rating plugs with different values, price and order separately.

Reference Publications

ProTrip™ Trip Unit Conversion Kits for GE Power Circuit Breakers - Fact Sheet	DET-228
ProTrip™ Trip Unit Conversion Kits for *Westinghouse Power Circuit Breakers - Fact Sheet	DET-230
ProTrip™ Trip Unit Conversion Kits for *Allis-Chalmers Power Circuit Breakers - Fact Sheet	DET-231
ProTrip™ Trip Unit Conversion Kits for *I-T-E Power Circuit Breakers - Fact Sheet	DET-229



Rating Plug

Rating Plugs

Frame Size (Amps)	Sensor Rating (Amps)	Current Rating (Amps)	Current Range (Amps)	Product Number
225 600 800	150	80	40-88	PT1C80GFD
225 600 800	150	100	50-110	PT1C100GFD
225 600 800	150	125	63-138	PT1C125GFD
225 600 800	150	150	75-165	PT1C150GFD ¹
225 600 800	225	150	75-165	PT225C150GFD
225 600 800	225	225	113-248	PT225C225GFD ¹
600	600	300	150-330	PT6C300GFD
600	600	400	200-440	PT6C400GFD
600	600	450	225-495	PT6C450GFD
600	600	500	250-550	PT6C500GFD
600	600	600	300-660	PT6C600GFD ¹
800	400	200	100-220	PT4C200GFD
800	400	225	113-248	PT4C225GFD
800	400	250	125-275	PT4C250GFD
800	400	300	150-330	PT4C300GFD
800	400	400	200-440	PT4C400GFD ¹
800 1600	800	400	200-440	PT8C400GFD
800 1600	800	450	225-495	PT8C450GFD
800 1600	800	500	250-550	PT8C500GFD
800 1600	800	600	300-660	PT8C600GFD
800 1600	800	700	350-770	PT8C700GFD
800 1600	800	800	400-880	PT8C800GFD ¹
1600	1600	800	400-880	PT16C800GFD
1600	1600	1000	500-1100	PT16C1000GFD
1600	1600	1100	550-1210	PT16C1100GFD
1600	1600	1200	600-1320	PT16C1200GFD
1600	1600	1600	800-1760	PT16C1600GFD
2000	2000	1000	500-1100	PT20C1000GFD
2000	2000	1200	600-1320	PT20C1200GFD
2000	2000	1500	750-1650	PT20C1500GFD
2000	2000	1600	800-1760	PT20C1600GFD
2000	2000	2000	1000-2200	PT20C2000GFD
3000	3000	1200	600-1320	PT30C1200GFD
3000	3000	1600	800-1760	PT30C1600GFD
3000	3000	2000	1000-2200	PT30C2000GFD
3000	3000	2500	1250-2750	PT30C2500GFD
3000	3000	3000	1500-3300	PT30C3000GFD ¹
4000	4000	1600	800-1760	PT40C1600GFD
4000	4000	2000	1000-2200	PT40C2000GFD
4000	4000	2500	1250-2750	PT40C2500GFD
4000	4000	3000	1500-3300	PT40C3000GFD
4000	4000	3600	1800-3960	PT40C3600GFD
4000	4000	4000	2000-4000	PT40C4000GFD ¹

¹Rating Plug furnished with conversion kit.

Note: Long Time pickup range is 0.5-1.1 times the rating plug value. 1.1 setting allows the breaker to carry 100% of the rating plug current value, not to exceed the continuous current (frame) rating of the breaker.

*I-T-E is a registered trademark of Siemens Energy and Automation, Inc.

*Westinghouse is a trademark of Westinghouse Electric Corporation.



Intentionally left blank.



Low Voltage Power & Insulated Case Circuit Breakers Section 8

EntelliGuard™ TU Trip Unit Conversion Kits Selection Guide

AKO25 C 3 F 06 04 A

GE	
Breaker	
AK-1-15	= AK115 ²⁶
AK-15	= AKO15 ¹
AK-1-25	= AK125 ²⁶
AK-25	= AKO25 ¹
AKU-25	= AKO25 ¹
AKR-30	
AKR-30H	= AKR30
AKRU-30	
AKR-30S	= AKR30 ²
AKRU-30S	
AK-1-50	= AK150
AK-50	
AKU-50 ³	
AKT-50	= AKO50 ¹
AKS-50	
AKSU-50 ³	
AKST-50	
AKR-50	
AKR-50H	
AKRU-50	
AKRT-50	
AKRT-50H	= AKR50 ⁴
AKJ-50	
AKJ-50H	
AKJT-50	
AKJT-50H	
AK-75 ³	= AKO75 ⁵
AKR-75	= AKR75 ⁵
AK-100 ³	= AKO100 ⁵
AKR-100	= AKR100 ⁵
AKW-100	= AKW100 ⁵

*Allis-Chalmers ²⁵	
Breaker	
LA	= ASL25 ⁹
LA-25A	= ASL2A ⁹
LA-600(Blue)	= ASL6B ^{17,18}
LAF-600(Blue)	= ASL6B ^{17,18,19}
LA-600(Gold)	= ASL6G ^{18,20}
LAF-600(Gold)	= ASL6G ^{18,19,20}
LA-50(800A)	= ASL58 ^{9,21}
LA-800	= ASL80 ^{18,20}
LAF-800	= ASL80 ^{18,19,20}
RL-800	= ASR80
RLX-800	= ASR16
RLE-800	= ASR80
LA-50(1600A)	= ASL51 ^{9,22}
LA-50(1600A)	= ASL52 ^{9,23}
LA-1600(Blue)	= ASL1B ^{17,18}
LAF-1600(Blue)	= ASL1B ^{17,18,19}
LA-1600(Gold)	= ASL1G ^{18,20}
LAF-1600(Gold)	= ASL1G ^{18,19,20}
RL-1600	= ASR16
RLX-1600	= ASR16
RLE-1600	= ASR16
RL-2000	= ASR0
LA-75	= ASL75 ⁹
LA-3000	= ASL30 ¹⁸
LA-3200(Blue)	= ASL3B ^{9,17,18}
LA-3200(Gold)	= ASL3G ^{9,18,20}
RL-3200	= ASR32
LA-4000(Blue)	= ASL4B ^{17,18,26}
LA-4000(Gold)	= ASL4G ^{18,20}
RL-4000	= ASR40

**I-T-E ²⁵	
Breaker	
KA	= AIKA2 ^{10,11}
K-225	= AIK22
KB (metal)	= AIKBM ¹²
KB (slate drawout)	= AIKBS ¹²
KB (slate stationary)	= AIKBX ¹²
K-600	= AIK60
KDON-600	= AIK60
KC (800A)	= AIKC8 ^{10,12,14}
K-800	= AIK80
KDON-800	= AIK80
KC (1600A)	= AIKC1 ^{10,12,13}
K-1600 (red)	= AIK16 ¹⁵
K-1600 (black)	= AIK1B ¹⁵
KDON-1600 (black)	= AIK1B ¹⁵
KDON-1600 (red)	= AIKN1
K-2000	= AIK20
KD	= AIKD3 ¹⁶
K-3000	= AIK30
KE	= AIKE4 ¹⁶
LG	= AIKG4 ⁹
K-4000	= AIK40

***Westinghouse ²⁵	
Breaker	
DB-15	= ADB15 ²⁶
DK-15	= ADK15 ⁹
DB-25	= ADB25
DBL-25	= ADB25
DK-25	= ADK25 ⁹
DS-206	= ADS06
DSL-206	= ADS06
DA-50	= ADA50 ⁹
DB-50	= ADB50
DBL-50	= ADB50
DS-416	= ADS16
DSL-416	= ADS16
DS-420	= ADS20
DS-532	= ADS53
DA-75	= ADA75 ⁹
DB-75	= ADB75
DS-632	= ADS32
DA-100	= ADA10 ⁹
DB-100	= ADB10
DS-840	= ADS40

Blue = Blue-gray breaker with plastic escutcheon
Gold = Gold breaker with metal escutcheon

Sensor Rating Selection

Frame	Sensors	Breaker Catalog Numbers			
		GE	*Allis-Chalmers	**I-T-E	***Westinghouse
225	150	AK-1-15, AK-15	Sensor rating not available.	KA, KA-225	DB-15, DK-15
	225				
600	150	AK-1-25, AK-25, AKU-25	LA-25, LA-25A, LA-600, LAF-600	KB, K-600, KDON-600	DB-25, DBL-25, DK-25
	225				
	600				
800	150	AKR-30, AKR-30H, AKRU-30, AKR-30S, AKRU-30S	LA-50 (800A Version), LA-800, LAF-800, RL-800, RLE-800, RLX-800	KC (800A Version), K-800, KDON-800	DS-206, DSL-206
	400				
	800				
1600	800	AK-1-50, AK-50, AKU-50, AKS-50, AKSU-50, AKR-50, AKR-50H, AKRU-50, AKJ-50, AKJ-50H	LA-50 (1600A Version), LA-1600, LAF-1600, RL-1600, RLE-1600, RLX-1600	KC (1600A Version), K-1600, KDON-1600	DA-50, DB-50, DBL-50, DS-416, DSL-416
	1600				
2000	2000	AKT-50, AKST-50, AKRT-50, AKRT-50H, AKJT-50, AKJT-50H	RL-2000	K-2000	DS-420
3000	3000	AK-75	LA-75, LA-3000	KD, K-3000	DA-75, DB-75
3200	3200	AKR-75	LA-3200, RL-3200	—	DS-632
4000	4000	AK-100, AKR-100, AKW-100	LA-4000, RL-4000	KE, LG, K-4000	DA-100, DB-100, DS-840

*Allis-Chalmers is a trademark of Allis-Chalmers Manufacturing Company Corporation.

**I-T-E is a registered trademark of Siemens Energy and Automation, Inc.

***Westinghouse is a trademark of Westinghouse Electric Corporation.



Low Voltage Power & Insulated Case Circuit Breakers Section 8

EntelliGuard™ TU Trip Unit

Conversion Kits Selection Guide

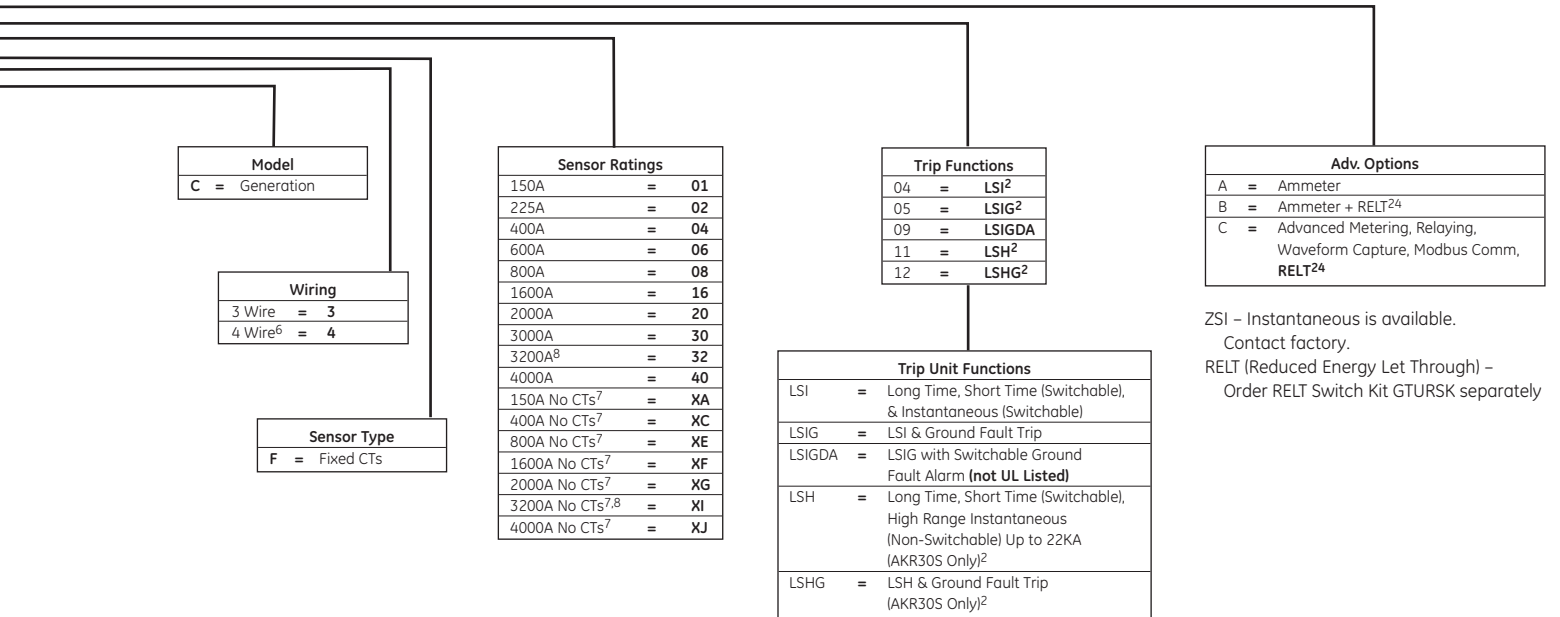

ZSI - Instantaneous is available. Contact factory.
 RELT (Reduced Energy Let Through) - Order RELT Switch Kit GTURSK separately

Reference Publications

EntelliGuard™ TU Conversion Kit Brochure	DET-722
EntelliGuard™ TU Conversion Kit Supplemental Instructions	DEH-3456
EntelliGuard™ TU Trip Unit Installation/Instruction Manual	DEH-4567
EntelliGuard™ TU Test Set - GTUTK20	DEH-4568A
GE AK-1-15, AK-1-25	GEH-6466
GE AK-1-50	DEH-40027
GE AK-15, AK, AKU-25, AKR-30S, AKRU-30S	GEH-5967
GE AKR-30,30H, AKRU-30, AKR-50, AKJ-50 Series	GEH-5966
GE AK-100, AK,U,T,S,SU,ST-50, AK-75	GEH-5965
GE AKR-100, AKR-75, AKW-100	GEH-5964
Westinghouse DB-15	GEH-6318
Westinghouse DB-25, DBL-25 (225A), DB-50, DBL-50	GEH-6319
Westinghouse DS-206, DSL-206, DS416, DSL-416, DS-420, DS-632	DEH-023
Westinghouse DB-100 (4000A), DB-75 (3000A)	GEH-6320
ITE K-1600 (red), K, KDON-1600 Black, K-2000, K-225, K-600, KDON-600, K-800, KDON-800, KDON-1600 (red)	GEH-6294
ITE KC (1600A), KC (800A)	GEH-6433
ITE KA	GEH-6293
ITE KB (Metal), KB (Slate Drawout), KB (Slate Fixed)	GEH-6295
ITE K-3000, K-4000	DEH-133
ITE KD-3000, KE-4000	DEH-40019
Allis Chalmers LA, LAF - 1600 (BLUE), LA, LAF-600 (BLUE)	DEH-40008
Allis Chalmers LA, LAF - 1600 (GOLD), LA, LAF-600 (GOLD), LA, LAF-800, RL, RLL, RLE-1600 & 800	DEH-40009A

- ¹For converting AK-2 version breakers and newer, not applicable for AK-1 or AKR.
- ²AKR30S Instantaneous Is Non-Switchable and the Non-Switchable High Range Instantaneous max is 22KA. LSH and LSHG Are Only Available on AKR30S.
- ³Breakers equipped with older style open fuse lockout devices (OFLO), must be retrofitted with newer style OFLO device prior to conversion process. Order replacement OFLO kits as follows: AKU-50 - order OFLO Kit #121C2870G2, AK-75 - order OFLO kit #121C2870G3, AK-100 - order OFLO kit #121C2870G4.
- ⁴Not applicable for converting breakers equipped with Power Sensor - contact factory.
- ⁵Contact the factory for stationary breaker applications.
- ⁶Only applicable to trip units with ground fault.
- ⁷Available only for MicroVersaTrip RMS-9 type AKR breakers equipped with fixed current sensors.
- ⁸Not available on AK-75 breaker frames.
- ⁹Contact factory for availability.
- ¹⁰Not applicable for slate version breakers.
- ¹¹Left pole accessories must be removed or relocated.
- ¹²Right pole accessories must be removed or relocated.
- ¹³1600-amp version of the KC breaker.
- ¹⁴800-amp version of the KC breaker.
- ¹⁵Order for red or black insulator as applicable.
- ¹⁶Not applicable to fixed mounted breakers.
- ¹⁷Only applicable for blue-gray color version breakers.
- ¹⁸Applicable to both "A" and "B" version breakers.
- ¹⁹Applicable to both nameplated versions of integral fused breakers (i.e., LA-600F and LAF-600).
- ²⁰Only applicable for gold color version breakers.
- ²¹800-amp version of the LA-50 breaker.
- ²²Only applicable for the 1600-amp, 6-pole primary disconnect version of the LA-50 breaker.
- ²³Only applicable for 1600-amp, 12 pole primary disconnect version of the LA-50 breaker.
- ²⁴Requires 24Vdc control power.
- ²⁵Existing Allis-Chalmers, I-T-E and Westinghouse bell alarms will not work with EntelliGuard TU.
- ²⁶Trip Unit will be mounted horizontally on breaker.

Note: Conversion Kit tables are located on pages 8-78 through 8-80.



Low Voltage Power & Insulated Case Circuit Breakers Section 8

EntelliGuard™ TU Trip Unit Conversion Kits Selection Guide

EntelliGuard™ TU are determined by the Frame Rating, Breaker Model, 3 or 4 wire, Trip Functions, and Advanced Features.
(Example: Items highlighted in bold **AKO25 C 3 F 06 04 A**)

For GE Power Circuit Breakers

EntelliGuard™ TU Trip Unit Conversion Kits for 3-Phase, 3-Wire

Frame Amps	Breaker Model	LSI (04)			LSIG (05)			LSIGDA (09)		
		Ammeter (A)	Ammeter + RELT (B)	All Advanced Options (C)	Ammeter (A)	Ammeter + RELT (B)	All Advanced Options (C)	Ammeter (A)	Ammeter + RELT (B)	All Advanced Options (C)
225	AK115									
	AKO15									
600	AK125									
	AKO25									
800	AKR30									
	AKR3S									
1600	AK150									
	AKO50									
2000	AK150									
	AKO50									
3000	AKR50									
	AKO75									
3200	AKR75									
	AKO10									
4000	AKR10									
	AKW10									

For GE Power Circuit Breakers

EntelliGuard™ TU Trip Unit Conversion Kits for 3-Phase, 4-Wire

Frame Amps	Breaker Model	LSI			LSIG (04)			LSIGDA (09)		
		Ammeter (A)	Ammeter + RELT (B)	All Advanced Options (C)	Ammeter (A)	Ammeter + RELT (B)	All Advanced Options (C)	Ammeter (A)	Ammeter + RELT (B)	All Advanced Options (C)
225	AK115									
	AKO15									
600	AK125									
	AKO25									
800	AKR30									
	AKR3S									
1600	AK150									
	AKO50									
2000	AK150									
	AKO50									
3000	AKR50									
	AKO75									
3200	AKR75									
	AKO10									
4000	AKR10									
	AKW10									

For *Allis-Chalmers Power Circuit Breakers

EntelliGuard™ TU Trip Unit Conversion Kits for 3-Phase, 3-Wire

Frame Amps	Breaker ¹ Model	LSI (04)			LSIG (05)			LSIGDA (09)		
		Ammeter (A)	Ammeter + RELT (B)	All Advanced Options (C)	Ammeter (A)	Ammeter + RELT (B)	All Advanced Options (C)	Ammeter (A)	Ammeter + RELT (B)	All Advanced Options (C)
600	ASL6B									
	ASL6G									
800	ASL80									
	ASR80									
1600	ASL1B									
	ASL1G									
2000	ASR16									
	ASR0									
3000	ASL30									
	ASR32									
3200	ASR40									
	ASL4G									
4000	ASL4B									

¹Contact factory for breaker models not listed.

*Allis-Chalmers is a trademark of Allis-Chalmers Manufacturing Company Corporation.



Low Voltage Power & Insulated Case Circuit Breakers Section 8

EntelliGuard™ TU Trip Unit Conversion Kits Selection Guide

For *Allis-Chalmers Power Circuit Breakers EntelliGuard™ TU Trip Unit Conversion Kits for 3-Phase, 4-Wire

Frame Amps	Breaker ¹ Model	LSI			LSIG (05)			LSIGDA (09)		
		Ammeter (A)	Ammeter + RELT (B)	All Advanced Options (C)	Ammeter (A)	Ammeter + RELT (B)	All Advanced Options (C)	Ammeter (A)	Ammeter + RELT (B)	All Advanced Options (C)
600	ASL6B									
	ASL6G									
800	ASL80									
	ASR80									
1600	ASL1B									
	ASL1G									
	ASR16									
2000	ASR0									
3000	ASL30									
3200	ASR32									
4000	ASR40									
	ASL4G									
	ASL4B									

For **I-T-E Power Circuit Breakers EntelliGuard™ TU Trip Unit Conversion Kits for 3-Phase, 3-Wire

Frame Amps	Breaker ¹ Model	LSI (04)			LSIG (05)			LSIGDA (09)		
		Ammeter (A)	Ammeter + RELT (B)	All Advanced Options (C)	Ammeter (A)	Ammeter + RELT (B)	All Advanced Options (C)	Ammeter (A)	Ammeter + RELT (B)	All Advanced Options (C)
225	AIKA2									
	AIK22									
600	AIKBM									
	AIKBS									
	AIKBX									
	AIK60									
800	AIKC8									
	AIK80									
1600	AIKC1									
	AIK16									
	AIK1B									
	AIKN1									
2000	AIK20									
3000	AIK30									
4000	AIK40									

For **I-T-E Power Circuit Breakers EntelliGuard™ TU Trip Unit Conversion Kits for 3-Phase, 4-Wire

Frame Amps	Breaker ¹ Model	LSI			LSIG (05)			LSIGDA (09)		
		Ammeter (A)	Ammeter + RELT (B)	All Advanced Options (C)	Ammeter (A)	Ammeter + RELT (B)	All Advanced Options (C)	Ammeter (A)	Ammeter + RELT (B)	All Advanced Options (C)
225	AIKA2									
	AIK22									
600	AIKBM									
	AIKBS									
	AIKBX									
	AIK60									
800	AIKC8									
	AIK80									
1600	AIKC1									
	AIK16									
	AIK1B									
	AIKN1									
2000	AIK20									
3000	AIK30									
4000	AIKE4									
	AIK40									

¹Contact factory for breaker models not listed.

*Allis-Chalmers is a trademark of Allis-Chalmers Manufacturing Company Corporation.

**I-T-E is a registered trademark of Siemens Energy and Automation, Inc.



Low Voltage Power & Insulated Case Circuit Breakers Section 8

EntelliGuard™ TU Trip Unit Conversion Kits Selection Guide

For *Westinghouse Power Circuit Breakers EntelliGuard™ TU Trip Unit Conversion Kits for 3-Phase, 3-Wire

Frame Amps	Breaker ¹ Model	LSI (04)			LSIG (05)			LSIGDA (09)		
		Ammeter (A)	Ammeter + RELT (B)	All Advanced Options (C)	Ammeter (A)	Ammeter + RELT (B)	All Advanced Options (C)	Ammeter (A)	Ammeter + RELT (B)	All Advanced Options (C)
225	ADB15									
600	ADB25									
800	ADS06									
1600	ADB50									
	ADS16									
2000	ADS20									
3000	ADB75									
3200	ADS32									
4000	ADB10									
	ADS40									

For *Westinghouse Power Circuit Breakers EntelliGuard™ TU Trip Unit Conversion Kits for 3-Phase, 4-Wire

Frame Amps	Breaker ¹ Model	LSI			LSIG (05)			LSIGDA (09)		
		Ammeter (A)	Ammeter + RELT (B)	All Advanced Options (C)	Ammeter (A)	Ammeter + RELT (B)	All Advanced Options (C)	Ammeter (A)	Ammeter + RELT (B)	All Advanced Options (C)
225	ADB15									
600	ADB25									
800	ADS06									
1600	ADB50									
	ADS16									
2000	ADS20									
3000	ADB75									
3200	ADS32									
4000	ADB10									
	ADS40									

¹Contact factory for breaker models not listed.

EntelliGuard™ TU Trip Rating Plug Specifications

Plug Rating	May Be Used With Trip Plug		Sensor Product Number
	Minimum Rating	Maximum Sensor	
60 A ²	150A ⁴	150A ⁴	GTP0060U0101
80A ²	150A ⁴	150A ⁵	GTP0080U0101
100A ³	150A ⁴	225A ⁵	GTP0100U0103
125A ²	150A ⁴	225A ⁵	GTP0125U0103
150A	150A ⁴	400A	GTP0150U0104
200A	200A ⁵	400A	GTP0200U0204
225A	225A	600A	GTP0225U0306
250A	400A	630A ¹	GTP0250U0407
300A	400A	800A	GTP0300U0408
350A	400A	800A	GTP0350U0408
400A	400A	1000A	GTP0400U0410
450A	600A	1200A	GTP0450U0612
500A	600A	1250A ¹	GTP0500U0613
600A	600A	1600A	GTP0600U0616
700A	800A	1600A	GTP0700U0816
750A	800A	2000A	GTP0750U0820
800A	800A	2000A	GTP0800U0820
900A	1000A	2000A	GTP0900U1020
1000A	1000A	2500A	GTP1000U1025
1100A	1200A	2500A	GTP1100U1225
1200A	1200A	3200A	GTP1200U1232
1500A	1600A	4000A	GTP1500U1640
1600A	1600A	4000A	GTP1600U1640
1900A	2000A	5000A	GTP1900U2050
2000A	2000A	5000A	GTP2000U2050
2200A	2500A	5000A	GTP2200U2550
2400A	2500A	6400A ⁶	GTP2400U2564
2500A	2500A	6400A ⁶	GTP2500U2564
3000A	3000A	6400A ⁶	GTP3000U3064
3200A	3200A	6400A ⁶	GTP3200U3264
3600A	4000A	6400A ⁶	GTP3600U4064
4000A	4000A	4000A ⁶	GTP4000U4040 ⁷
4000A	4000A	6400A ⁶	GTP4000U 4064
5000A	5000A	6400A ⁶	GTP5000U5064
6000A	6000A	6400A ⁶	GTP6000U6064

²WavePro and AKR only. EntelliGuard™ G min. trip plug is 150A.

³PowerBreak only. EntelliGuard™ G min. trip plug is 150A.

⁴WavePro and AKR only. EntelliGuard™ G min. sensor is 400A.

⁵PowerBreak only. EntelliGuard™ G min. sensor is 400A.

⁶IEC only sensor, UL equivalents are 600A.

⁷For ITE and Allis Chalmers 4000A breakers.

*Westinghouse is a trademark of Westinghouse Electric Corporation.



Low Voltage Power & Insulated Case Circuit Breakers

EntelliGuard™ TU Trip Unit

Conversion Kit Accessories and Hardware

AK, AKR, Westinghouse, ITE, Allis Chalmers Conversion Kits

- EntelliGuard TU trip unit and rating plug
- Direct acting flux shifter with automatic reset
- Epoxy encapsulated high-accuracy current transformers
- Specially designed mounting hardware and wire harnesses with communication cable and RELT harness for easy upgrade later
- Detailed instruction manual



EPIC, RMS9, MVT+, MVT PM Upgrade Options

- EntelliGuard TU trip unit and rating plug
- RELT and Ground Fault Alarm Harness Kits (see below)
- RELT Switch with warning labels kit – GTURSK
- Communication cable for Modbus & 24 VDC
- Power Break II carrier plate assemblies (authorized service only)
- WavePro secondary disconnect kits



Harness Kits and Hardware to add RELT (Reduced Energy Let Through)

Breakers	Component	Product Number	Description
All	24V Power Supply	PLPS4G01	Power Leader 1.5A power supply for up to 15 trip units
	RELT Switch Kit	GTURSK	Includes blue lighted RELT switch, lockable cover, contacts, 8' wire harness, warning labels (see picture above)
	RELT Harness Kit	GTURHB	4 wire RELT & Ground Fault Alarm harness kit. Used to add RELT or Ground Fault Alarm to an existing MVT installation in combination with an EntelliGuard TU. Harness comes with breaker and cubicle side, 8 feet of wire, terminal block, and RELT labels. Includes 9 pin harness for 24VDC, communications, and voltage source.
AK, AKR, Allis Chalmers, ITE, Westinghouse	RELT Harness Kit	GTURHA	4 wire RELT & Ground Fault Alarm harness kit. Used to add RELT or Ground Fault Alarm to an existing MVT installation in combination with an EntelliGuard TU. Harness comes with breaker and cubicle side, 8 feet of wire, terminal block, and RELT labels ¹
WavePro - 800-2000A	RELT Harness Kit	GTURHWP1	6 wires (4 for RELT, 2 for 24VDC) from trip unit to secondary disconnect block. Used to add RELT to an existing MVT Installation.
WavePro - 3200-4000A	RELT Harness Kit	GTURHWP2	6 wires (4 for RELT, 2 for 24VDC) from trip unit to secondary disconnect block. Used to add RELT to an existing MVT Installation.



Low Voltage Power & Insulated Case Circuit Breakers Section 8

EntelliGuard™ TU Trip Unit Conversion Kit Accessories and Hardware

Harness Kits and Hardware to add RELT (Reduced Energy Let Through) (continued)

Breakers	Component	Product Number	Description
WavePro - 5000A	RELT Harness Kit	GTURHWP3	6 wires (4 for RELT, 2 for 24VDC) from trip unit to secondary block. Used to add RELT to an existing MVT installation.
WavePro - All Frames	WavePro "C" Disconnect Block	GTUSDWP1	WavePro breaker side secondary disconnect "C"
WavePro - 800-2000A	WavePro "C" Disconnect Block	GTUSFSD361	WavePro equipment side secondary disconnect "C", includes 36 wire harness ¹
WavePro - 3200-5000A	WavePro "C" Disconnect Block	GTULFSD361	WavePro equipment side secondary disconnect "C", includes 36 wire harness ¹
Power Break I - All Frames	Power Break I Disconnect Block	TDOSD6S	Power Break I secondary disconnect 6 circuit drawout - equipment side
		TDOSD6B	Power Break I secondary disconnect 6 circuit drawout - breaker side
		TDOSVD04	Power Break I secondary disconnect with Zone Interlocking
Stationary Power Break II	RELT Harness Kit	GTURHPB2S	6 wires (4 for RELT, 2 for 24VDC) and complete wired carrier plate. Used to add RELT to an existing MVT installation. (Installation by authorized service only)
Drawout Power Break II	RELT Harness Kit	GTURHPB2D	6 wires (4 for RELT, 2 for 24VDC), complete wired carrier plate, and 6 wire harness from terminal block to secondary disconnect. Used to add RELT to an existing MVT installation. (Installation by authorized service only)
Power Break II - All Frames	Power Break II "B" Disconnect Block	SPDOSD36S	Power Break II secondary disconnect block B - equipment side
	Power Break II "B" Disconnect Block	SPDOSD36B	Power Break II secondary disconnect block B - breaker side

¹WavePro equipment side secondary disconnect "C" is available as 16 wire harness: GTUSFSD361 and GTULFSD361.

Additional Key Components

Breakers	Component	Product Number	Description
All	ZSI Module	TIM1	Zone Selective Interlock Module/Repeater
	Voltage Conditioners (set of 3)	PLVC1G01	Supplies isolated bus voltage signal from PT's to EntelliGuard Trip Units (PT's not included)
	Voltage Conditioners Plate (set of 3)	See Page 8-45 BuyLog	Voltage Conditioners and Potential Transformers mounted on a metal plate with fuses
	Voltage Conditioner, PTs (set of 3) and Power Supply	See Pub DEP-056A	Includes Voltage Conditioners, Potential Transformers, 24V DC and Fuses all mounted on one Metal Plate
	EntelliGuard TEST Kit	GTUTK20	Used for testing phase currents, ground fault, disabling ground fault, RELT. Ability to Trip Breaker and used to connect to a PC with Set-up Software to download settings
	Rating Plug Removal Tool	TRTOOL	Simplifies rating plug removal
	Set-up Software	GTUSS	Set-up EntelliGuard Trip Unit offline or connected. Ability to view Waveform Captured by Trip Unit
AK, AKR, Allis Chalmers, ITE, Westinghouse	9 Pin Wire Harness Equipment side	GTUCHCONV1	9 Pin Equipment side wire harness 8' long for 24VDC, Communications, Voltage Conditioner Input
WavePro - All Frames	Plastic Door Kit	10060051P3	WavePro Trip Unit Plastic Door
Power Break I - All Frames	Power Break Micro Switch	See Pub DEH40391	Replacement Microswitch on Power Break I's with EPIC Trip Units
Power Break II - All Frames	Plastic Door Kit	10054335P3	Power Break II Trip Unit Plastic Door

²RELT and Ground Fault Alarm require 24VDC. If 24VDC cable is required order GTURHB

EntelliGuard™ TU Trip Units are compatible with MicroVersaTrip™, RMS9, EPIC RMS9, MicroVersaTrip™ Plus and PM, Enhanced MicroVersaTrip™ Plus and PM Trip Units models.

Now Available:
Power Break™ II in a Power Break™ I (fixed and drawout)
EntelliGuard™ R Retrofill (EntelliGuard™ G in AKD-5, AKD-6, AKD-8 switchgear line-ups)
 Contact factory for availability and options

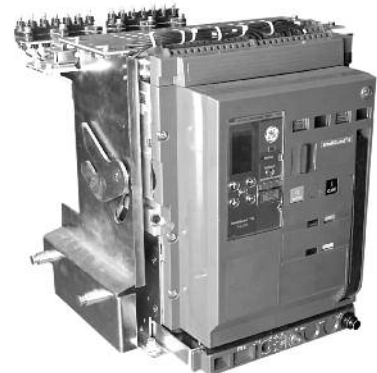

Accessories

Optional Remote Display—Features

- Provides safe, convenient closed-door access to breaker metering, status and setup functions
- Available for use with either MicroVersaTrip™ Plus or MicroVersaTrip™ PM trip units
- Rugged plastic NEMA Type 1 enclosure with LCD and keypad
- Mounts easily on outside of breaker compartment door
- Sealable, clear LEXAN protective cover over display and "Enter" key prohibits unauthorized trip setting changes
- Connects to breaker trip unit via 20-pin plug-in cable for fast installation
- Breaker trip unit operates independently if cable is disconnected



Optional Remote Display

Optional Remote Display (for MicroVersaTrip™)

Accessory Type	Product Number
Remote Display w/ 6' Cable	REMDIS1
Replacement Cable	REMDIS2



Target Module

Target Module (for ProTrip™)

All ProTrip™ conversion kits come with a target module. Order another only for renewal purposes.

Product Number
TARGET02P

GE Trip Unit Portable Test Set (for MicroVersaTrip™ and ProTrip™)

Allows for self-tests and functioning trip/no trip tests. Operates on batteries (not included) or 120 VAC source.

Product Number
TVRMS2



GE Trip Unit Portable Test Set

EntelliGuard™ TU Test Set

Allows for self-tests and functioning trip/no trip tests. Operates on batteries (not included) or 120 VAC source.

Product Number
GTUTK20



EntelliGuard™ TU Test Set



Low Voltage Power & Insulated Case Circuit Breakers Section 8

Trip Unit

Accessories

POWER LEADER™ Power Supply

The POWER LEADER™ power supply provides 24Vdc control power to MicroVersaTrip™ PM trips units used on WavePro low voltage power circuit breakers. The control power is required for the trip unit's communication and protective relay functions.

Description	Product Number	System Requirements (Not included with power supply)
1.5A power supply. Maximum wire length from power supply to trip device is 100 feet. A maximum of 45 trip units may be powered from a single power supply.	PLPS4G01	Input power, 100VA (85-265 Vac or 100-370 Vdc)

POWER LEADER™ Voltage Conditioner

Conditions and scales 120Vac to 1.76Vac for use by the trip unit for voltage sensing. Provides transient protection. Requires isolation PTs with 120 volt secondary. Supports up to 15 trip units at a maximum distance of 20 feet. Required for PM trip units only.

Description	Product Number	System Requirements (Not included with voltage conditioners)
Supplies isolated bus voltage signal to MicroVersaTrip™ PM trip units.	PLVC1G01	One set of 3 voltage conditioners required for each sensing location. PTs also required.

MicroVersaTrip™ Portable Power Pack

The MicroVersaTrip™ Portable Battery Pack is a maintenance power source used to power up trip units for setting or adjusting trip set points or for reading trip targets when the trip unit is not otherwise energized. It is a redundant power source to the onboard battery supplied with the Enhanced MicroVersaTrip™ Plus and PM (5-button keypad) trip units. The portable battery pack connects to the trip unit through the rating plug test jack. It requires three (3) standard 9Vdc alkaline batteries (not included).

Description	Product Number
MicroVersaTrip™ Portable Power Pack	TVPPB

MicroVersaTrip™ and EntelliGuard™ Rating Plug Removal Tool

Description	Product Number
MicroVersaTrip™ and EntelliGuard™ Rating Plug Removal Tool	TRTOOL



Low Voltage Power & Insulated Case Circuit Breakers Section 8 Asbestos Free Arc Quencher Replacement Kits

GE's Asbestos Free Arc Quencher Replacement Kits are designed to replace asbestos plate style arc quenchers on AK and early AKR power circuit breakers with reliable, proven steel plate style arc quenchers used on modern AKR breakers. The kits have been ANSI C37.59 tested for dielectric and short circuit ensuring breaker performance to original specifications. On most AK series breakers, no modifications are needed to install the arc quencher replacement kit. Installation is typically done in less than one hour (see Installation Instructions GEH-6464). Asbestos Free Arc Quencher replacement kits are shipped complete with detailed installation instructions and everything you need for fast and easy arc quencher replacement:

- Asbestos free metal plate or ceramic arc quenchers
- Contact guides and arc runners (when required)
- Asbestos free replacement barriers (when required)
- All required mounting hardware

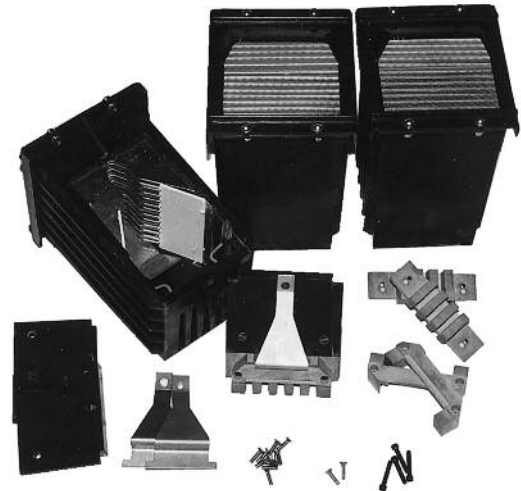

Reference Publications

Asbestos Free Arc Quencher Replacement Kits	DET-096
Installation Instructions	GEH-6464

Product Number Selection

Breaker	AKO25	AQR1	G1	Application
Model				
AK-15		AQR1 Arc Quencher Replacement Kit		For Asbestos Removal G1
AK-25 AKO25 ^{1,2,3}		Generation 1		Renewal Kit for G2
AKU-25				Ceramic Arc Quenchers
AKR-30S AKR3S ^{1,2}				
AKR-30 AKR30				
AKRU-30				
AKR-30H AKR3H				
AKRU-30H				
AK-50				
AKT-50 AKO50 ^{2,3}				
AKU-50				
AKJ-50				
AKJT-50				
AKJU-50 AKR50				
AKR-50				
AKRT-50				
AKRU-50				
AKJ-50H				
AKJT-50H				
AKJU-50H AKR5H				
AKR-50H				
AKRT-50H				
AKRU-50H				
AKJ-50				
AKJT-50 AKD50 ⁴				
AKJU-50				
AKJ-50H				
AKJT-50H AKD5H ⁴				
AKJU-50H				
AK-75 AKO75 ^{2,3}				
AKR-75 AKR75 ²				
AK-100 AKO10 ^{2,3}				
AKR-100 AKR10 ²				

Arc Quenchers Replacement Kit

Product Number	
AKO25AQR1	G1
AKR35AQR1	G1
AKR30AQR1	G1
AKR30AQR1	G2
AKR3HAQR1	G1
AKR3HAQR1	G2
AKO50AQR1	G1
AKR50AQR1	G1
AKR50AQR1	G2
AKR5HAQR1	G1
AKR5HAQR1	G2
AKD50AQR1	G1
AKD50AQR1	G2
AKD5HAQR1	G1
AKD5HAQR1	G2
AKO75AQR1	G1
AKR75AQR1	G1
AKO10AQR1	G1
AKR10AQR1	G1

¹Kits contain replacement barriers only, arc quenchers do not contain asbestos.
²G2 kits are not available for these breakers, please contact the factory for individual replacement arc quenchers.
³Does not apply to AK-1 series breakers.
⁴These kits are for use on breakers used in AKD and AKD-5 switchgear and substructures.



Low Voltage Power & Insulated Case Circuit Breakers Section 8

Gerapid High Speed DC Circuit Breakers

Typical Traction Electric Power System

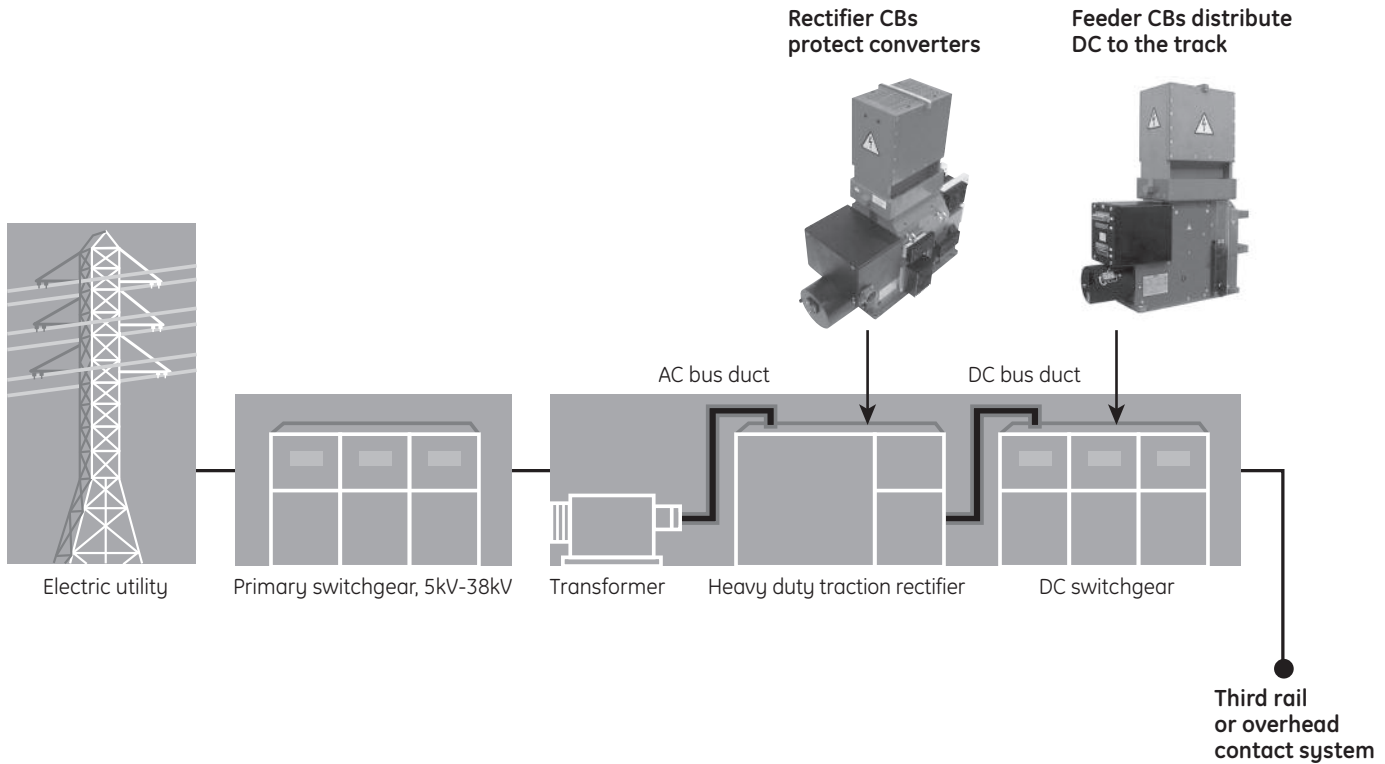

In addition to traction substation applications, Gerapid can be used as a feeder breaker in various other installations such as industrial plants (metals industry), as field breakers for motor and generator field applications, and as disconnects for DC drives, to name a few.

Circuit Breaker Features and Accessories

- Insulated side plates with adjustable dial for setting over current trip (OCT) (optional)
- Mechanical forced tripping
- Electrodynamic trip device (with or without capacitor and charging unit)
- Shunt trip
- No-voltage release
- Breaker auxiliary contacts (up to 10 form C)
- Additional auxiliary contacts for signaling (optional)
- Main terminal configurations variable
- Plug connectors for auxiliary circuits (optional)
- Hand lever for manual actuation from front (for maintenance purposes only)
- Position indication (optional)
- Internal power supply with a wide range of supply voltage options
- Integrated current measurement unit (SEL) (optional)
- Mechanical counter

Key Benefits

- Standard dimensions from 2,600A to 6,000A (feeder models GER2607 – GER8007)
- Operating voltages from 1,000 to 3,600Vdc
- Mining and traction compliant (ANSI C37.14, IEC 947-2, EN 50123-2). Also available with UL label.
- High speed OPEN/TRIP (opening delay <3ms)
- Direct acting instantaneous and adjustable trip unit works without imported energy and is available as bidirectional symmetrical (for line feeder) or unidirectional (for rectifier breaker)
- High speed CLOSE (approximately 150 ms)
- Solenoid drive (integral control unit, mechanically latched, no auxiliary power required to keep contacts closed)
- 2-stage contact system minimizes contact wear
- Compact, enclosed construction
- Modular, serviceable design
- Easily accessible control and auxiliary connections
- Fixed and draw-out versions
- Extensive accessories/options

General Information

Rated Temperature	-5° to 40°C ambient (55°C with reduced ratings)
Relative Humidity	90% @ T<20°C, RH=130-2*T @ T>20 °C
Altitude	-120m to 2000m above sea level



Gerapid Breaker Modules

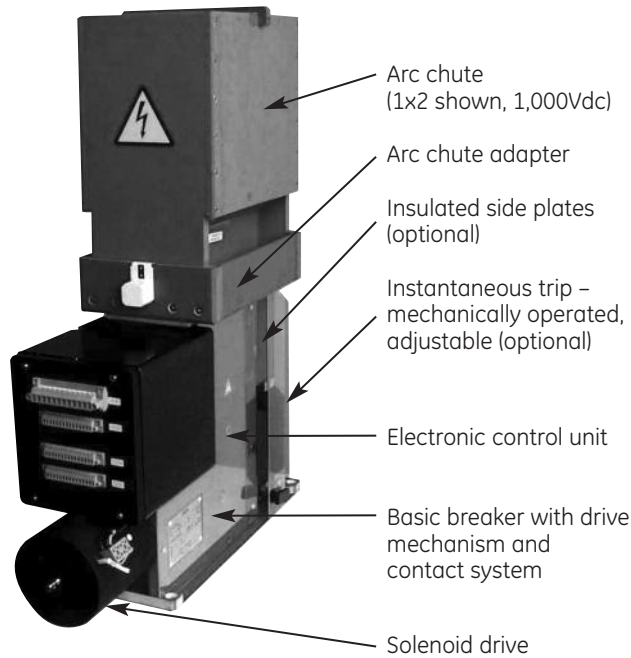

Power and Control Connections

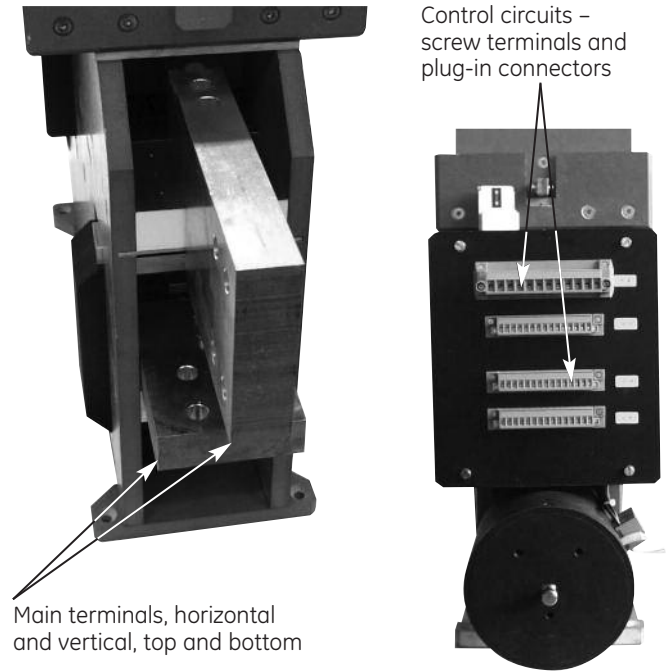

Type SEL Current Measurement System (optional on 2607 and 4207)

- Current measurement at the breaker
- Factory-equipped or field-installable
- No additional space required or breaker modifications
- Ranges 6kA and 12kA
- To 4,000Vdc
- Signal output via 3 interfaces
 - 4...20mA
 - +/- 20mA
 - +/- 10V
- Watchdog function standard



Low Voltage Power & Insulated Case Circuit Breakers Section 8

Gerapid High Speed DC Circuit Breakers

Technical Data for Feeder Circuit Breaker Models 2607 through 8007

Breaker type	Gerapid 2607					Gerapid 4207					Gerapid 6007					Gerapid 8007	
	1X2	1X4	2X2	2X3	2X4	1X2	1X4	2X2	2X3	2X4	1X2	1X4	2X2	2X3	2X4	1X2	2X2
Arc chute type																	
Conventional thermal current I_{th} [A]	2600					4200					6000					8000	
Rated current [A]	2600					4150					N/A					6000	
Rated voltage U_{Ne} [V]	1000	2000	2000	3000	3600	1000	2000	2000	3000	3600	1000	2000	2000	3000	3600	1000	2000
Rated maximum voltage [V]	800	N/A	N/A	N/A	N/A	800	N/A	1600	N/A	N/A	N/A	N/A	N/A	N/A	N/A	800	N/A
Rated insulation voltage U_i [V]	2000	2000	2000	3000	4000	2000	2000	2000	3000	4000	1000	2000	2000	3000	4000	1000	2000
Short time current 120 min [A]	3150					5000					7200					9600	
Short time current 2 min [A]	5200					8500					12000					16000	
Short time current 20 sec [A]	7800					12600					18000					24000	
Impulse withstand voltage 1.2/50 μ s U_i [kV] according to EN 50124-1:1997	18	18	18	30	30	18	18	18	30	30	12	18	18	30	*	12	18
Power frequency withstand voltage 50 Hz U_d [kVeff] according to EN 50124-1:1997	10	10	10	15	15	10	10	10	15	15	7	10	10	15	*	7	10
Rated short circuit making capacity I_{Nss} [kA]	70	50	100	50	42	70	50	100	50	42	70	50	80	50	*	70	*
Rated short circuit breaking capacity according to EN 50123-2	50	35	71	35	30	50	35	71	35	30	50	35	56	35	*	50	50
Rated service short circuit breaking current according to IEC 947-2	60	40	50	40	40	60	40	50	40	40	60	40	50	40	*	60	*
Short circuit current according to IEEE C37.14 [kA]	120					120					60					120	
Peak current according to IEEE C37.14 [kA]	200					200					100					200	
Maximum short circuit current [kA] tested at customer request	244	120	100		52	244	120	100		52	200					240	
Maximum arc voltage U_{arc} [kV]	2	4	4	5.6	7	2	4	4	5.6	7	2	4	4	5.6	7	2	4
Weight ca. [kg]	120	120	160	160	160	120	120	160	160	160	150	150	165	165	165	190	210
Weight ca. [lbs]	265	265	352	352	352	265	265	352	352	352	331	331	364	364	364	419	463

*Test data available at customer request

Technical Data for Rectifier Circuit Breaker Models 8007R and 10007R

Parameter	Reference	Gerapid 8007R		Gerapid 10007R	
		1x2	1x3	1x2	1x3
Arc chute type	N/A				
Rated continuous current [A]	ANSI C37.14 p.5.3	6000	6000	8000	8000
2 hours current [A]	N/A	7200	7200	9600	9600
2 minutes current [A]	N/A	12000	12000	16000	16000
20 seconds current [A]	N/A	18000	18000	24000	24000
Rated short-time current (250ms) [kA]	ANSI C37.14 p.5.5	90 (149 peak)	60 (100 peak)	90 (149 peak)	60 (100 peak)
Rated maximum voltage [V]	ANSI C37.14 p.5.2	800	1200	800	1200
Rated insulation voltage - U_{Nm} [V]	EN 50124-1 p.1.3.2.4	2000	2000	2000	2000
Rated impulse voltage - U_{Ni} [kV]	EN 50124-1 p.1.3.2.7	18 [12/50 μ s]	18 [12/50 μ s]	18 [12/50 μ s]	18 [12/50 μ s]
Power frequency voltage - U_G [kV]	EN 50124-1 a.B.2.2	10 [1 minute 50 Hz]	10 [1 minute 50 Hz]	10 [1 minute 50 Hz]	10 [1 minute 50 Hz]
Mechanical endurance [cycles] ¹	N/A	10000	10000	10000	10000
Rated short circuit peak / sustained current [kA] ^{2,3}	ANSI C37.14 p.5.4	200 / 120	132 / 80	200 / 120	132 / 80
Short-circuit characteristic	Tests a, b, c, d acc. ANSI C37.14 annex A	High-speed	High-speed	High-speed	High-speed
Maximum arc voltage [V]	N/A	2500	2500	2500	2500
Mass ca.	N/A	220 kg	220 kg	220 kg	220 kg

¹10000 cycles without parts replacement. Inspection after 5000 cycles. Max. 5000 cycles by means of ED impulse coil or POCT release.

²Tested for high and low frequency impedance bonds.

³Trip by means of POCT (direct-acting, instantaneous, electromechanical and polarized OC release) or by means of ED impulse coil with no intentional delay

To configure Gerapid OEM Modules and DC Circuit Breakers, visit our web wizard configuration tool at:
http://www.geindustrial.com/cwc/Dispatcher?REQUEST=PRODUCTS&id=gerapid&lang=en_US



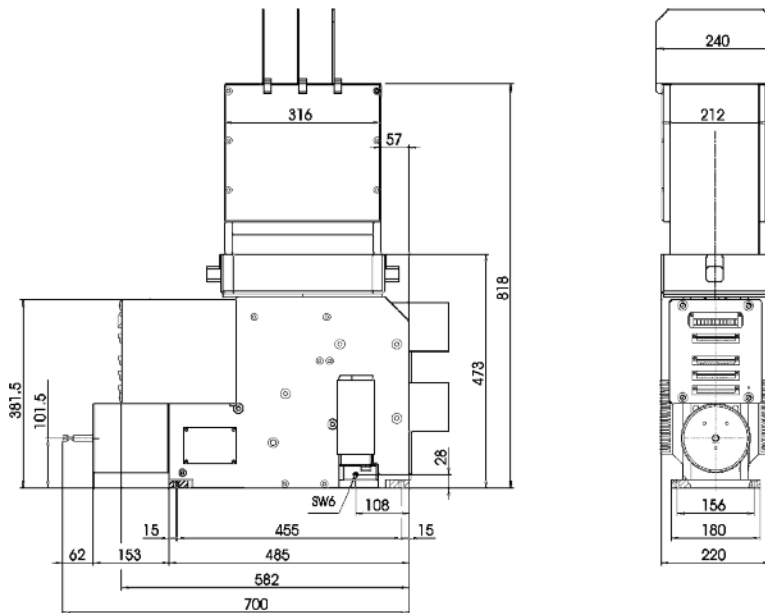

Figure 1. Models 2607 - 6007 Feeder CBs, 1X4 Arc Chute, 2,000Vdc (Dimensions in mm)

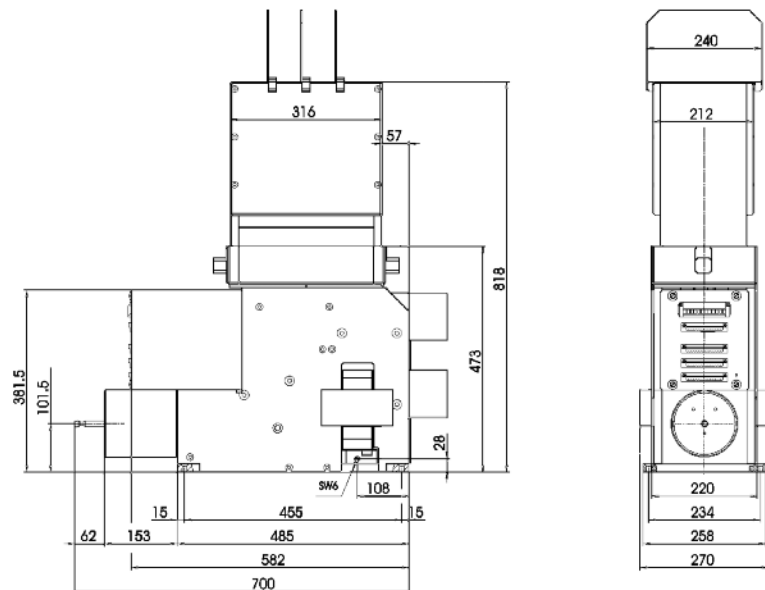

Figure 2. Gerapid 8007 Feeder CBs, 1X4 Arc Chute, 2,000Vdc (Dimensions in mm)



Features

Power Break™ II Circuit Breakers

The Insulated Case Circuit Breaker—GE pioneered the design and created the name in 1965. GE Power Break™ II insulated case circuit breakers are the latest in reliable, flexible and easy-to-use circuit protection.

Power Break™ II circuit breakers are UL Listed, CSA and IEC-947-2 Certified for up to 200,000 amperes, at 240 volts rms symmetrical interrupting capacity without fuses or current limiters. These new insulated case circuit breakers rated 200-4000A can be applied on ac power systems through 600 volts. All breaker frames, except 4000A stationary, are UL Listed to carry 100% of their ampere rating continuously. All frames are suitable for reverse feeding.

All Power Break™ II circuit breakers are available in two levels of interrupting capacity—"standard break" and "Hi-Break" breakers. Each interrupting level is available in both stationary and draw-out construction, with a full complement of control and signaling accessories.

Standard break breakers are designed to meet the majority of application requirements, calling for moderate levels of available short-circuit current.

Hi-Break breakers are specially designed to withstand the stresses, and safely interrupt high levels of short-circuit current found in some applications (from 65 to 200 kA rms symmetrical amperes—depending on voltage).

Greater Convenience and Operational Safety

The controls and status indicators you need most are readily accessible. The flush-mounted handle, ON/OFF buttons, rating plug test receptacle, bell alarm reset buttons — with or without lockout — are easily reached and all are double-insulated from live components. And, for added security, a standard padlock device lets you prevent accidental or unauthorized closing of the breaker.

Power Break™ II circuit breakers are versatile and designed for a wide variety of applications including temperature insensitive trip units, push-to-open and close control, charge-after-close operation, 3 cycle closing, UL listed (file E 11592) field installable accessories suitable for 50/60 Hz. All accessories and control wiring are prewired to dedicated, secondary terminal points on each breaker.

Quick, Error-Free Installation of Universal Accessories

Drop-in bell alarm, bell alarm with manual reset lockout, shunt trip, shunt trip with lockout, and undervoltage release install in seconds. No special tools. No breaker disassembly. Just slide them into place. The modules are universal across all frame sizes and each is mechanically keyed to its compartment so you make the right connection, every time. These accessories are field installable and upgradable.



GE's innovative, modular, drop-in accessories provide the ultimate customer solution for field customization:

UL Listed

- Accessory combination (one each) shunt trip, undervoltage release, bell alarm (alarm only), bell alarm with lockout.
- Rated 12-250 Vdc through 12-240 Vac, continuous duty.

Complete installation in seconds without special tools, breaker disassembly or adjustment

- The user can select how protective trip unit functions, the shunt trip (with or without lockout), and UVR accessories interface with the bell alarm and bell alarm with lockout accessories: An overcurrent, shunt trip, or UVR trip can be set to actuate the bell alarm or bell alarm with lockout. Any combination of output actions based on inputs can be selected.
- Shunt trip and undervoltage trip targets are clearly displayed by the trip unit LCD.

Pre-wired wire harness makes field installation a snap for:

- Motor operator with remote charge indicator
- Auxiliary switches, up to 12-stage maximum
- Remote close solenoid

Additional field-installable accessories including:

- Kirk Key locks (4 maximum)
- Limited access ON/OFF cover
- Mechanical operations counter
- Door interlock
- Walking beam interlock for stationary and draw-out breakers.

Ratings for Global Use

- Performance ratings include IEC947-2 certification.



Power Break™ II

Construction Options

The interruption ratings and voltages shown in the table are maximum ratings. A circuit breaker of the type given in the left-hand column may be applied at the given circuit voltage in any electrical distribution system where the available fault current at the load terminals of the breaker does not exceed the value in the table. That circuit breaker type may also be applied at intermediate values of circuit voltage provided the available fault current at the load terminals of the breaker does not exceed the value in the table for the higher value of voltage.



Insulated Case Circuit Breakers

	Circuit Breaker Envelope Size (Amperes)	EntelliGuard™ TU	Trip Types		Molded Case Switch	Max IC @ 480V (kA)	Max Voltage Rating (ac)	Max Frame (Amperes)
			Power+	MicroVersaTrip™ Plus/PM				
Power Break™ II								
Standard	800	X	X	X		65	600	800
	1600	X	X	X		65	600	1600
	2000	X	X	X		65	600	2000
	3000	X	X	X		100	600	3000
	4000	X	X	X		100	600	4000
Hi-Break	800	X	X	X		100	600	800
	1600	X	X	X		100	600	1600
	2000	X	X	X		100	600	2000
	3000	X	X	X		150	600	3000
	4000	X	X	X		150	600	4000
Molded Case Switch	800				X	30 ¹	600	800
	1600				X	40 ¹	600	1600
	2000				X	40 ¹	600	2000
	2500				X	42 ¹	600	2500
	3000				X	42 ¹	600	3000
	4000				X	42 ¹	600	4000

¹Molded case switch ratings are short time @ 600Vac, not interrupting current. See page 8-108 for withstand ratings.



EntelliGuard™ TU Trip Units

New capabilities in the EntelliGuard™ TU Trip Unit provide ultimate system reliability and selectivity without sacrificing circuit protection. This superior addition enhances the Power Break™ II breaker with a Waveform Recognition Instantaneous Algorithm that eliminates costly downtime due to nuisance tripping. It enables harmonic analysis four cycles prior and after an event, and discerns whether a downstream breaker/fuse is clearing the fault. The unit also includes Zone Selective Interlocking (can be used as a feeder and downstream device with a power circuit breaker upstream) which delivers simultaneous and independent ZSI of Short Time, Ground Fault and Instantaneous protection, providing the ability to overlap the Instantaneous on the Main and Feeder breakers. Together, these innovative abilities achieve Hazard Risk Category 2 (HRC2) with currents as high as 100kA with simultaneous flash protection and selectivity.

The EntelliGuard™ TU Trip Unit offers optimum circuit safety and arc flash protection with the Reduced Energy Let-Through function, providing a faster instantaneous trip that may be used if faster and more sensitive protection is required temporarily. It is commonly referred to as an “Arc Flash Switch” or “Maintenance Switch”.

The new and improved trip unit design delivers selectivity tools not previously available in GE circuit breakers:

Exclusive EntelliGuard™ TU Trip Unit Features

Designed for Flexibility

- A wide range of continuous adjustment Long Time delays ensure the circuit breaker can be exactly adjusted in to your selectivity and protection needs.
- Multiple Short Time diagonal bands tune your protection to exactly where it needs to be.
- Flexible time current settings and curves -Standard Long Time characteristics exactly mimic the curve of a thermal magnetic circuit breaker.
- Flexible Time Current Curves: 44 Long Time Shapes I²T and I⁴T (fuse), 3 Short Time I²T slopes, Short Time adjustable in 55 ms increments, and 4 Ground Fault curves to select from (I²T, I⁴T, SGF, Define Time Slope)

Instantaneous Protection

- Instantaneous pick-up is adjustable up to 15 times the plug rating on frames 800-2000A, 13 times on 3000A frames and up to 9 times on 4000A frames.
- A separately adjustable fast instantaneous trip - useful for when the circuit must provide the best possible protection and arc flash performance while sustaining normal load.
- An override instantaneous - provides fast tripping for the largest bolted fault currents to minimize potential damage.
- Up to 17 Short Time bands allow you to set your circuit breaker to sustain load requirements without slowing protection.
- Ground Fault Alarm via I/O or Modbus Communications
- Ground fault protection with faster time bands, multiple slopes and the ability to coordinate a 1200A ground fault with an 800A circuit breaker - a ratio four times better than in previous generation trip units



Maintenance and Diagnostics

- Universal trip plug fits any trip unit.
- Flexible serial communication via Modbus RTU
- Integrates directly into GE's EnerVista™ Power Management System.
- Large backlit LCD with detailed, easy-to-see descriptions.
- Health status via breaker LED indicating normal operation, errors, pickup, and trips while providing non-volatile memory with a continuous self-testing microprocessor
- Lithium battery to eliminate need for external power for set-up and review
- 10 event Log with Date/Time Stamp: Stores the last 10 events. Date/Time with 24Vdc Power.
- Thermal Memory
- WaveForm Capture: 40 Samples/Cycle, 4 cycles prior and 4 cycles post event in COMTRADE format.
- Free set-up software



Low Voltage Power & Insulated Case Circuit Breakers Section 8

Power Break™ II Circuit Breakers

Power + Trip Unit Features

Power+ Trip Unit Systems

The Power+ trip unit system for Power Break™ II insulated case breakers consist of the trip unit, the trip actuator, current sensors and rating plugs. The term “trip unit system” applies to the combination of these four components which form the solid-state circuit breaker tripping system.

Power+ trip units provide a complete range of standard and optional overcurrent and ground-fault protective functions.



True RMS Sensing

The Power+ trip unit continues to use GE’s proven technique of measuring true rms currents of both sinusoidal and harmonically distorted waveforms. The frequent sampling (48 times per cycle per phase) allows precise calculations of true rms current. The sampling rate allows waveform measurements up to the 11th harmonic. GE’s true rms sensing avoids potential underprotection or overprotection problems associated with peak-sensing tripping systems.

Accessory Integration

Four accessories are integrated through the Power+ trip unit. Drop-in shunt trip (with or without lockout), bell alarms (with or without lockout) and the undervoltage release modules fit into keyed pockets. They operate through the trip units, and not through any external mechanisms. All accessory wiring is pre-wired to secondary terminals, and no user wiring is necessary. When activated, the shunt trip (with or without lockout) and undervoltage release modules send a signal to the trip unit to energize the trip actuator and open the breaker.

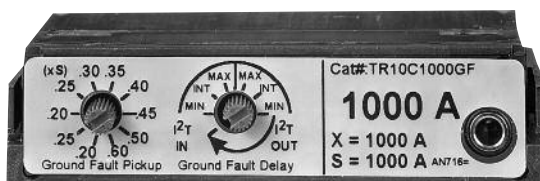

Power+ Trip Target Module

Trip Target Module (Optional)

View Button: Press the VIEW button to check the trip unit status.

Reset Button: Press the RESET button to clear any target that is set.

Battery check: Target modules use two standard, 3V, 16mm x 1.6mm, lithium batteries for viewing target information. Battery life depends upon use, but may be estimated at one year. When the batteries are energized, depressing the VIEW button will illuminate either a set target LED, i.e., LT or the BAT LED. Once target indicators are cleared, battery status is indicated by the BAT LED. Replacement batteries include Panasonic CR1616, Eveready E-CR1616BP, or Duracell DL1616B, which may be purchased commercially.

Long-time pickup: The long-time pickup indicator moves through two transitions. As the current in any phase reaches 95% of its setpoint; the LTPU LED begins to flash. As current increases, flashing frequency increases, until 100% of the pickup point is reached. At that moment, the LTPU LED stays on continuously until the long-time delay times out. Once the breaker has tripped on long-time, the Overload target will be stored in memory. To view the trip, press the VIEW button. To clear the target, press the RESET button.

Short-time and instantaneous trips: Short-time and instantaneous trips share the same trip target. The LTPU LED is not illuminated, since the time intervals between pickup and tripping are too short for either function. Once the breaker has tripped on short-time or instantaneous, the short target will be stored in memory. To view the trip, press the VIEW button. To clear the target, press the RESET button.

Ground fault trip (Target02 only): The trip target for a ground fault trip is the GF LED. To view the trip, press the view button. To clear the target, press the RESET button.

Health monitor: Trip unit health status “okay” is illustrated by slow blinking of the LTPU LED. It may be seen by depressing and holding the VIEW button. Sufficient power must be supplied to the trip unit via external test kit, power pack, or current transformers for the health monitor to be operational.

Standard and Optional Protective Functions

Standard and optional protective functions are available for Power+ trip units. The breaker settings are programmed in multiples of “X” (rating plug ampere values), “S” (current sensor ampere rating values), and “C” (the long-time setting in amperes—multiply long-time setting by rating plug ampere rating).

Standard

- Adjustable Long-Time (L) Pickup, 0.5 - 1.0X, with four delay bands.
- Adjustable Instantaneous (I) Pickup, 1.5 - 15X.

Options

- Overload, Short Circuit, and Short-Time local trip indicators with overload pickup warning and health monitor.
- Adjustable Short-Time (S) Pickup, 1.5 - 9.0C, and delay (3 bands) with I²t ON/OFF selection.
- Adjustable Ground Fault (G) Pickup, 0.2 - 0.6S, and delay¹ (3 bands) with I²t ON/OFF selection and trip indicator.
- Upgradeable Ground Fault function with use of appropriate ground fault rating plug.

¹Limited by breaker frame size above 2000A.



Enhanced MicroVersaTrip™ Trip Unit Features

Enhanced MicroVersaTrip™ Trip Units

Enhanced MicroVersaTrip™ Plus and MicroVersaTrip™ PM trip units give you two new ways to monitor and control the Power Break™ II breaker with unprecedented ease. Through the simple keypad, the trip unit lets you program and display a variety of functions including tripping characteristics, remote communications, status information and protective relaying, and allows integration with GE POWER LEADER™ Power Management Systems. The trip unit display also allows viewing of many standard metering parameters as well as pickup alarms, trip target indications and fault status information.

Enhanced MicroVersaTrip™ Plus and MicroVersaTrip™ PM trip units continue to use GE's proven technique of measuring true rms currents (and voltages for MicroVersaTrip™ PM trip units) of both sinusoidal and harmonically distorted waveforms. The frequent sampling (64 times per cycle) allows precise calculations of true rms current. The sampling rate allows waveform measurements up to the 31st harmonic to achieve accuracies of 99%. GE's true rms sensing avoids potential underprotection or overprotection problems associated with peak-sensing tripping systems. The enhanced trip unit design includes a wide range of functions and adds many new features:

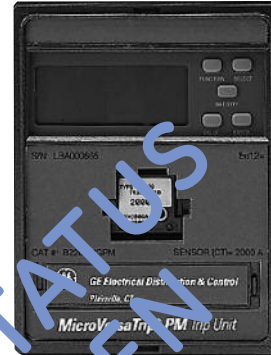

Enhanced MicroVersaTrip™ Plus and MicroVersaTrip™ PM Trip Units have been specifically designed to integrate with the extensive capabilities offered by Power Break™ II circuit breakers.

UL Listed Field-Interchangeable

Non-volatile trip targets display/Cold setup capability

- Replaceable long-life batteries provide trip target indications and cold setup capability—without the need for external power or a battery pack.

Trip operations counter

- The number of long-time, short-time, instantaneous and ground fault trips are individually counted and displayed.

Trip information

- On overcurrent faults, the trip unit displays fault pickup, the type of fault, the magnitude of the fault current and the phase the fault occurred on.
- Display indicates when a shunt trip or undervoltage release trip has opened the breaker.

New display

- Ergonomic, 5-button keypad
- New targets with international symbols
- High-resolution LCD display for local 3-phase ammetering
- New status and setup displays for greater ease of use
- True rms sensing for accurate response to high harmonic content waveforms for Long-Time, Short-Time, and Ground Fault protection.
- 50/60 Hz operation.
- Interchangeable, UL Listed trip units and rating plugs with test set jack for TVRMS2 test set.
- EMI immunity per ANSI C37.90.

Features exclusive to MicroVersaTrip™ PM Trip Units

Communications

- All information can be viewed on the LCD display or communicated over a POWER LEADER™ Power Management System network.

Demand/peak demand

- The trip unit can display a rolling average of power demand and peak power demand at user-selected intervals from 5 to 60 minutes.

Local and remote metering

- Amps, volts, frequency
- Real power, total power
- Accumulated energy

Protective relays include:

- Current and voltage unbalance
- Overvoltage
- Undervoltage
- Power reversal
- Power reversal direction setup



Low Voltage Power & Insulated Case Circuit Breakers Section 8

Power Break™ II Circuit Breakers

Trip Unit Characteristics

EntelliGuard™ TU Trip Unit Characteristics

Envelope Size	Frame Max. Ampere Rating	Sensor Rating (Amperes) (S)	Long Time				Short Time			
			Current Setting (C) (Pick-Up) Multiple of Rating Plug Amperes (X)		Delay ² (Seconds)		Pick-up (Multiple of Current Settings) (C)	Delay (Seconds)		
					Thermal Type (C-Bands)	Fuse Type (F-Bands)				
800	800	200, 400, 800			0.20	0.025	1.5 thru 9.0 in Increments of 0.5	I ² T in ¹ Minimum - .046 Intermediate- .186 Maximum - .418		
					0.60	0.025				
					1.21	0.025				
					1.61	0.032				
1600	1600	800, 1000, 1600	0.5 thru 1.0 in Increments of 0.05		2.41	0.044		1.5 thru 9.0 in Increments of 0.5	I ² T out ² .025, .033, .042, .058, .092, .117, .158, .183, .217, .350, .417	
					3.21	0.059				
					4.02	0.078				
					4.82	0.100				
2000	2000	2000			5.62	0.130			1.5 thru 9.0 in Increments of 0.5	I ² T out ² .025, .033, .042, .058, .092, .117, .158, .183, .217, .350, .417
					6.43	0.170				
					7.23	0.220				
					8.04	0.270				
3000	2500	1000, 2000, 2500			9.64	0.350	1.5 thru 9.0 in Increments of 0.5			I ² T out ² .025, .033, .042, .058, .092, .117, .158, .183, .217, .350, .417
					11.20	0.440				
					12.90	0.550				
					14.50	0.690				
4000	4000	4000			16.10	0.870		1.5 thru 9.0 in Increments of 0.5		I ² T out ² .025, .033, .042, .058, .092, .117, .158, .183, .217, .350, .417
					17.70	1.100				
					19.30					

Trip Unit Characteristics (continued)

Envelope Size	Adjustable Instantaneous Pick-Up without ST (Multiple of Rating Plug Amperes) (X)	Adjustable Instantaneous Pick-Up with ST (Multiple of Rating Plug Amperes) (X)	Ground Fault						
			RELT without ST	RELT with ST	Pick-Up (Multiple of Sensor Ampere Rating)	Delay with I ² T in Seconds	Slope Bands	Fixed Delay	
800	2.0 thru 10.0 in 0.5 increments	2.0 thru 15.0 in 0.5 increments	1.5 thru 10.0 in 0.5 increments	1.5 thru 15.0 in 0.5 increments	0.20 thru 0.60 in increments of 0.01			I ² t - .385	0.058
									0.092
1600	2.0 thru 10.0 in 0.5 increments	2.0 thru 15.0 in 0.5 increments	1.5 thru 10.0 in 0.5 increments	1.5 thru 15.0 in 0.5 increments	0.20 thru 0.60 in increments of 0.01			I ² t - .385	0.117
									0.158
2000	2.0 thru 10.0 in 0.5 increments	2.0 thru 15.0 in 0.5 increments	1.5 thru 10.0 in 0.5 increments	1.5 thru 13.0 in 0.5 increments	0.20 thru 0.60 in increments of 0.01		.44 at 200% of pick-up at lower level of band	I ⁴ T - .179	0.183
									0.217
3000	2.0 thru 10.0 in 0.5 increments	2.0 thru 13.0 in 0.5 increments	1.5 thru 10.0 in 0.5 increments	1.5 thru 13.0 in 0.5 increments	0.20 thru 0.37 in increments of 0.01		SGF - .553		0.350
									0.417
4000	2.0 thru 9.0 in 0.5 increments	2.0 thru 9.0 in 0.5 increments	1.5 thru 9.0 in 0.5 increments	1.5 thru 9.0 in 0.5 increments	0.20 thru 0.30 in increments of 0.01				0.517
									0.617
									0.717
									0.817
									0.917

Additional Features and Characteristics of the EntelliGuard™ TU Trip Unit

Function	Description	Trip Unit Character 9														
		1	2	3	4	5	6	7	8	9	X	A ³	B ³	C ³	D ³	E ³
Metering																
Communications	Modbus Communications Bus Link		•					•				•				•
Amperes (A, kA) ²	Selectable Phase Current ± 2.5%	•	•		•	•	•	•			•	•	•	•	•	•
Voltage (V)	L-L or L-N Volts ±1.5%				•	•	•	•				•	•	•	•	•
Energy (kWh, MWh, GWh)	Total Energy Usage on Brkr ± 4%				•	•	•	•				•	•	•	•	•
Real Power (kW/MW)	L-L or L-N Power ± 4%				•	•	•	•				•	•	•	•	•
Total Power (kVA/MVA)	L-L or L-N Power ± 4%				•	•	•	•				•	•	•	•	•
Frequency (Hz)	Circuit Frequency ± 1Hz				•	•	•	•				•	•	•	•	•
Demand & Peak Demand (kW)					•	•	•	•				•	•	•	•	•
Relaying																
Under Voltage Trip	Adjustable pickup, 50-90%					•									•	
	Adjustable delay, 1-15 seconds OFF								•							•
Over Voltage Trip	Adjustable pickup, 110-150%						•									•
	Adjustable delay, 1-15 seconds OFF								•							•
Voltage Unbalance	Adjustable pickup, 10-50%									•						•
	Adjustable delay, 1-15 seconds OFF										•					•
Current Unbalance	Adjustable pickup, 10-990kW														•	•
	Adjustable delay, 1-15 seconds OFF														•	•
	Power Reversal Direction															
Data Acquisition - Waveform Capture																
RELT		•	•		•	•	•	•							•	•

³Used when Ground Fault Alarm is needed via the output contact.

Additional Features and Characteristics of the EntelliGuard™ TU Trip Unit

Trip Unit Character 3	Zone Selective Interlocking	Power Break™ II
Z	ZSI, Short time and GF; user selectable	•
T	Z + IOC ZSI; user selectable	• ¹
X	NONE SELECTED	•

¹Instantaneous out only. ²Time delay shown at lower limit of each band. All pick-up tolerances are ±10%.



Low Voltage Power & Insulated Case Circuit Breakers Section 8

Power Break™ II Circuit Breakers

Trip Unit Characteristics

Power+ Trip Unit Characteristics

Envelope Size	Frame Max. Ampere Rating	Sensor Rating (Amperes) (S)	Long-Time		Short-Time	
			Current Setting (C) (Pick-Up) Multiple of Rating Plug Amperes (X)	Delay ¹ (Seconds 4 Bands)	Pick-up (Multiple of Current Setting) (C)	Delay (Seconds 3 Bands)
2000	800	200, 400, 800	0.5, 0.6, 0.7, 0.8, 0.9, 0.95 and 1.0	2.4, 4.9, 9.8, 20	1.5, 2.0, 2.5, 3.0, 4.0, 5.0, 7.0, and 9.0	$I^2T_{in}^1$.10, .21, .35
	1600	800, 1000, 1600				$I^2T_{out}^2$.10, .21, .35
	2000	2000				
3000	2500, 3000	1000, 2000, 2500, 3000				
4000	4000	4000				

Power+ Trip Unit Characteristics (continued)

Envelope Size	Adjustable Instantaneous Pick-Up without ST (Multiple of Rating Plug Amperes) (X)	Adjustable Instantaneous Pick-Up with ST (Multiple of Rating Plug Amperes) (X)	Ground Fault	
			Pick-Up (Multiple of Sensor Ampere Rating)	Delay ³ (Seconds 3 Bands)
2000	1.5 thru 10.0	1.5 thru 15.0	0.20 thru 0.60	$I^2T_{in}^4$.10, .21, .35
	1.5 thru 10.0	1.5 thru 15.0	0.20 thru 0.60	$I^2T_{out}^2$.10, .21, .35
	1.5 thru 10.0	1.5 thru 15.0	0.20 thru 0.60	
3000	1.5 thru 10.0	1.5 thru 13.0	0.20 thru 0.37	
4000	1.5 thru 9.0	1.5 thru 9.0	0.20 thru 0.30	

Enhanced MicroVersaTrip™ Plus and PM Trip Unit Characteristics

Envelope Size	Frame Max. Ampere Rating	Sensor Rating (Amperes) (S)	Long-Time		Short-Time	
			Current Setting (C) (Pick-Up) Multiple of Rating Plug Amperes (X)	Delay ² (Seconds)	Pick-up (Multiple of Current Setting) (C)	Delay (Seconds)
800	800	200, 400, 800	0.5 thru 1.0 in increments of 0.05	2.4, 4.9, 9.8, 20	1.5 thru 9.0 in increments of 0.5	$I^2T_{in}^1$ 0.40
1600	1600	800, 1000, 1600				
2000	2000	2000				
3000	2500	1000, 2000, 2500				
	3000	3000				
4000	4000	4000			$I^2T_{out}^2$.10, .21, .35	

Trip Unit Characteristics (continued)

Envelope Size	Adjustable Instantaneous Pick-Up without ST (Multiple of Rating Plug Amperes) (X)	Adjustable Instantaneous Pick-Up with ST (Multiple of Rating Plug Amperes) (X)	High Range Instantaneous (Multiple of Frame Short-Time Rating) (H)	Ground Fault		
				Pick-Up (Multiple of Sensor Ampere Rating)	Delay With I^2T In Seconds	Delay ³ With I^2T Out Seconds
800	1.5 thru 10.0 in 0.5 increments	1.5 thru 15.0 in 0.5 increments	1.0	0.20 thru 0.60 in increments of 0.01	.44 at 200% of pick-up at lower limit of band	.10, .21, .35
1600	1.5 thru 10.0 in 0.5 increments	1.5 thru 15.0 in 0.5 increments		0.20 thru 0.60 in increments of 0.01		
2000	1.5 thru 10.0 in 0.5 increments	1.5 thru 15.0 in 0.5 increments		0.20 thru 0.60 in increments of 0.01		
3000	1.5 thru 10.0 in 0.5 increments	1.5 thru 13.0 in 0.5 increments		0.20 thru 0.37 in increments of 0.01		
4000	1.5 thru 9.0 in 0.5 increments	1.5 thru 9.0 in 0.5 increments		0.20 thru 0.30 in increments of 0.01		

¹Time delay shown at 600% of current setting at lower limit of band.

²Time delay shown at lower limit of each band. All pick-up tolerances are ± 10%.

³Time delay shown at lower limit of each band. Ground fault pick-up not to exceed 1200 amperes.

⁴Time delay shown at 200% of pick-up at lower limit of band.

X = Rating plug amps
S = Sensor amp rating
C = Long-time current setting (pick-up)
H = Short-Time Rating



Low Voltage Power & Insulated Case Circuit Breakers Section 8

Power Break™ II Circuit Breakers

Trip Unit Characteristics (continued)

Additional Features and Characteristics Exclusive to the Enhanced MicroVersaTrip™ PM Trip Unit¹

Function	Description	Trip Unit Suffix		
		M (Metering)	P (Relaying)	PM (Metering & Relaying)
Communications	—POWER LEADER Communications Bus Link	STD	STD	STD
Amperes (A, kA) ²	Selectable Phase Current ±2.5%	STD	STD	STD
Voltage (V)	L-L or L-N Volts ±1.5%	•		•
Energy (kWh, MWh, GWh)	Total Energy Usage on Brkr ±4%	•		•
Real Power (kW/MW)	L-L or L-N Power ±4%	•		•
Total Power (kVA/MVA)	L-L or L-N Power ±4%	•		•
Frequency (Hz)	Circuit Frequency ± 1Hz	•		•
Demand & Peak Demand (kW)		•		•
Under Voltage Trip	—Adjustable pickup 50-90% —Adjustable delay, 1-15 seconds OFF		•	•
Over Voltage Trip	—Adjustable pickup, 110-150% —Adjustable delay, 1-15 seconds OFF		•	•
Voltage Unbalance	—Adjustable pickup, 10-50% —Adjustable delay, 1-15 seconds OFF		•	•
Current Unbalance	—Adjustable pickup, 10-50% —Adjustable delay, 1-15 seconds OFF		•	•
Power Reversal	—Adjustable pickup, 10-990 kW —Adjustable delay, 1-15 seconds OFF —Power Reversal Direction		•	•

¹ MicroVersaTrip PM™ functions require 24 Vdc control power.

² Ampere reading also standard on MicroVersaTrip Plus trip units.



Low Voltage Power & Insulated Case Circuit Breakers Section 8

Power Break™ II Circuit Breakers

Power Break™ II Nomenclature System

Step 7 Metering, RELT, Communication, Relays, ZSI (Example)

Trip Unit Type + Features	Character 7		
POWER +	X		
Metering	None		
Communication	None		
Relays	None		
ZSI	None		

ENHANCED MVT™	X	A	B
Metering	Current	Current	Current
Communication	None	None	None
Relays	None	None	None
ZSI	None	GF	GF&ST

ENHANCED MVT™ PM	C	D	E	F	G	H	J	K	L
Metering	Current	Current	Current	Full	Full	Full	Full	Full	Full
Communication	COMNET	COMNET	COMNET	COMNET	COMNET	COMNET	COMNET	COMNET	COMNET
Relays	P	P	P	None	None	None	P	P	P
ZSI	None	GF	GF&ST	None	GF	GF&ST	None	GF	GF&ST

ENTELOGUARD™ TU	X	A	B	C	D	E	F	G	H	J	K	L	M	N
Metering	Current	Current	Current	Current ¹		Full	Full ¹		Full	Full ¹	Current	Current	Current	Current ¹
RELT	None	RELT	RELT	None ¹		RELT	None ¹		RELT	None ¹	None	RELT	RELT	None ¹
Communication	None	None	Modbus	Modbus ¹		Modbus	Modbus ¹		Modbus	Modbus ¹	None	None	Modbus	Modbus ¹
Relays	None	None	None	None ¹		None	None ¹		YES	YES ¹	None	None	None	None ¹
ZSI	None	None	None	None ¹		None	None ¹		None	None ¹	GF&ST	GF&ST	GF&ST	GF&ST ¹

Trip Unit Type + Features	Character 7 (continued)															
ENTELOGUARD™ TU	P	Q	R	V	W	Y	Z	1	2	3	4	5	6	7	8	9
Metering		Full	Full ¹		Full	Full ¹	Current ¹	Current ¹	Current ¹	Current ¹		Full ¹	Full ¹		Full ¹	Full ¹
RELT		RELT	None ¹		RELT	None ¹	None ¹	RELT ¹	RELT ¹	None ¹		RELT ¹	None ¹		RELT ¹	None ¹
Communication		Modbus	Modbus ¹		Modbus	Modbus ¹	None ¹	None ¹	Modbus ¹	Modbus ¹		Modbus ¹	Modbus ¹		Modbus ¹	Modbus ¹
Relays		None	None ¹		YES	YES ¹	None ¹	None ¹	None ¹	None ¹		None ¹	None ¹		YES ¹	YES ¹
ZSI		GF&ST	GF&ST ¹		GF&ST	GF&ST ¹	GF&ST ¹	GF&ST ¹	GF&ST ¹	GF&ST ¹		GF&ST ¹	GF&ST ¹		GF&ST ¹	GF&ST ¹

¹Zone Selective Instantaneous Ground Fault & Short Time & Instantaneous (out)

Step 8 Overcurrent Protection Package (Example)

Character 8	Package	Character 8	Package
X	None (switch)	7	LSHG
1	LI	8	LIG
2	LSI ²	9	LIGA
3	LSIG ²	A	LIGD
4	LSIGA ²	B	LSHGA
5	LSIGD ²	C	LSHGD
6	LSH	D	LSIH

²EntelliGuard™ TU Trip Unit only offers these



Low Voltage Power & Insulated Case Circuit Breakers Section 8

Power Break™ II Circuit Breakers

Power Break™ II Nomenclature System

Step 9 Trip Unit Rating Plug (Example)

Character 9	EntelliGuard™ TU Trip Unit	MicroVersaTrip™ Plus and Enhanced MicroVersaTrip™ PM Trip Unit	Power +	Rating Plug	Availability by Current Sensor Rating (shaded areas indicate availability)									
					200	400	800	1000	1600	2000	2500	3000	4000	
X				X										
A	•	•	•	100	■									
B	•	•	•	150	■	■								
C	•	•	•	200	■	■	■							
D	•	•	•	225	■	■	■	■						
E	•	•	•	250	■	■	■	■	■					
F	•	•	•	300	■	■	■	■	■	■				
G	•	•	•	350	■	■	■	■	■	■	■	■	■	■
H	•	•	•	400	■	■	■	■	■	■	■	■	■	■
I	•	•	•	450	■	■	■	■	■	■	■	■	■	■
J	•	•	•	500	■	■	■	■	■	■	■	■	■	■
K	•	•	•	600	■	■	■	■	■	■	■	■	■	■
L	•	•	•	700	■	■	■	■	■	■	■	■	■	■
M		•		750	■	■	■	■	■	■	■	■	■	■
N	•	•	•	800	■	■	■	■	■	■	■	■	■	■
O	•	•	•	900	■	■	■	■	■	■	■	■	■	■
P	•	•	•	1000	■	■	■	■	■	■	■	■	■	■
Q	•	•	•	1100	■	■	■	■	■	■	■	■	■	■
R	•	•	•	1200	■	■	■	■	■	■	■	■	■	■
S	•	•	•	1250	■	■	■	■	■	■	■	■	■	■
T	•	•	•	1500	■	■	■	■	■	■	■	■	■	■
U	•	•	•	1600	■	■	■	■	■	■	■	■	■	■
V	•	•	•	1900	■	■	■	■	■	■	■	■	■	■
W	•	•	•	2000	■	■	■	■	■	■	■	■	■	■
Y	•	•	•	2200	■	■	■	■	■	■	■	■	■	■
Z	•	•	•	2400	■	■	■	■	■	■	■	■	■	■
1	•	•	•	2500	■	■	■	■	■	■	■	■	■	■
2	•	•	•	3000	■	■	■	■	■	■	■	■	■	■
3	•	•	•	3200	■	■	■	■	■	■	■	■	■	■
4	•	•	•	3600	■	■	■	■	■	■	■	■	■	■
5	•	•	•	4000	■	■	■	■	■	■	■	■	■	■

¹Exclusive for MicroVersaTrip™ Plus and Enhanced MicroVersaTrip™ PM Trip Unit Rating Plugs
²Exclusive for EntelliGuard™ TU Trip Unit Rating Plugs only

Step 10 Shunt Trip (Example)

Character 10	Voltage	With Lockout	Without Lockout
0	None		•
1	12Vdc		•
2	24Vac/24Vdc		•
3	48Vac/48Vdc		•
4	120Vac/125Vdc		•
5	208Vac		•
6	240Vac/250Vdc		•
7	480Vac		•
8	600Vac		•
H	12Vdc	•	
J	24Vac/24Vdc	•	
K	48Vac/48Vdc	•	
L	120Vac/125Vdc	•	
M	208Vac	•	
N	240Vac/250Vdc	•	
P	480Vac	•	
R	600Vac	•	

Step 11 Bell Alarm, Bell Alarm With Lockout, Kirk Key Provision (Example)

Character 11	Bell Alarm	Bell Alarm w/Lockout ³	Kirk Key Provision ⁴
0	None	None	None
1	None	240	None
2	None	600	None
4	240	None	None
5	240	240	None
6	240	600	None
8	600	None	None
9	600	240	None
A	600	600	None
G	None	None	4
H	None	240	4
J	None	600	4
L	240	None	4
M	240	240	4
N	240	600	4
R	600	None	4
S	600	240	4
T	600	600	4

³Bell Alarm ratings Vac
⁴Kirk Key Provision number of key locks 1-4
 Note: 600Vac module not UL Listed.



Low Voltage Power & Insulated Case Circuit Breakers Section 8

Power Break™ II Circuit Breakers

Power Break™ II Nomenclature System

Step 12 UnderVoltage Release, Racking Padlock (Example)

Character 12	UnderVoltage Release	Racking Padlock ¹
0	None	None
1	24Vac	None
2	48Vac	None
3	120Vac	None
4	208Vac	None
5	240Vac	None
6	480Vac	None
7	600Vac	None
8	12Vdc	None
9	24Vdc	None
A	48Vdc	None
B	125Vdc	None
C	250Vdc	None
G	None	All
H	24Vac	All
J	48Vac	All
K	120Vac	All
L	208Vac	All
M	240Vac	All
N	480Vac	All
P	600Vac	All
R	12Vdc	All
S	24Vdc	All
T	48Vdc	All
U	125Vdc	All
V	250Vdc	All

¹Frame Rating

Step 13 Electric Operator, Push Button Cover, Hidden On (Example)

Character 13	Electric Operator	Push Button Cover	Hidden On
0	None	None	None
1	120Vac	None	None
2	240Vac	None	None
3	24Vdc	None	None
4	48Vdc	None	None
5	72Vdc	None	None
6	125Vdc	None	None
8	None	YES	None
9	120Vac	YES	None
A	240Vac	YES	None
B	24Vdc	YES	None
C	48Vdc	YES	None
D	72Vdc	YES	None
E	125Vdc	YES	None
G	None	None	YES
H	120Vac	None	YES
J	240Vac	None	YES
K	24Vdc	None	YES
L	48Vdc	None	YES
M	72Vdc	None	YES
N	125Vdc	None	YES
R	None	YES	YES
S	120Vac	YES	YES
T	240Vac	YES	YES
U	24Vdc	YES	YES
V	48Vdc	YES	YES
W	72Vdc	YES	YES
X	125Vdc	YES	YES

Step 14 Closing Solenoid, Door Interlock, Counter (Example)

Character 14	Closing Solenoid	Door Interlock	Counter
0	None	None	None
1	120Vac	None	None
2	240Vac	None	None
3	24Vdc	None	None
4	48Vdc	None	None
5	72Vdc	None	None
6	125Vdc	None	None
8	None	YES	None
9	120Vac	YES	None
A	240Vac	YES	None
B	24Vdc	YES	None
C	48Vdc	YES	None
D	72Vdc	YES	None
E	125Vdc	YES	None
G	None	None	YES
H	120Vac	None	YES
J	240Vac	None	YES
K	24Vdc	None	YES
L	48Vdc	None	YES
M	72Vdc	None	YES
N	125Vdc	None	YES
R	None	YES	YES
S	120Vac	YES	YES
T	240Vac	YES	YES
U	24Vdc	YES	YES
V	48Vdc	YES	YES
W	72Vdc	YES	YES
X	125Vdc	YES	YES

Step 15 Auxiliary Switch, Stationary/Draw-out, Trimplate (Example)

Character 15	Auxiliary Switch	Stationary/Draw-out	Trimplate
0	None	Stationary	None
1	4-240V	Stationary	None
2	8-240V	Stationary	None
3	12-240V	Stationary	None
4	4-600V	Stationary	None
5	8-600V	Stationary	None
8	None	Stationary	YES
9	4-240V	Stationary	YES
A	8-240V	Stationary	YES
B	12-240V	Stationary	YES
C	4-600V	Stationary	YES
D	8-600V	Stationary	YES
H	4-240V	Drawout	None
J	8-240V	Drawout	None
K	12-240V	Drawout	None
L	4-600V	Drawout	None
M	8-600V	Drawout	None
S	4-240V	Drawout	YES
T	8-240V	Drawout	YES
U	12-240V	Drawout	YES
V	4-600V	Drawout	YES
W	8-600V	Drawout	YES



Low Voltage Power & Insulated Case Circuit Breakers Section 8

Power Break™ II Circuit Breakers

Power Break™ II Nomenclature System

Power Break™ II Circuit Breaker Frame Product Numbers

S	S	D	08	*	02	H¹
Power Break™ II Breaker Type						Auxiliary Function
S = Standard break						H = High-range instantaneous current sensors
H = Hi-Break™ breaker						Blank = Standard current sensors
Construction						Current Sensor Rating
D = Drawout						02 = 200 A 20 = 2000 A
F = Stationary, front connected						04 = 400 A 25 = 2500 A
B = Back connected, 2500 – 3000 A only						08 = 800 A 30 = 3000 A
						10 = 1000 A 40 = 4000 A
						16 = 1600 A
Frame Rating						Trip Unit Type and Rating
08 = 800 A 25 = 2500 A						B2/D2 = 2000 A maximum
16 = 1600 A 30 = 3000 A						B3/D3 = 2500 A, 3000 A
20 = 2000 A 40 = 4000 A						B4/D4 = 4000 A
						Y = Insulated case switch
						B for Enhanced MicroVersaTrip™ Plus and MicroVersaTrip™ PM trip unit
						D for Power+™

¹High-range instantaneous sensors only available on MicroVersaTrip™ Plus and MicroVersaTrip™ PM units.

NOTE: This information is provided only for use interpreting product numbers. It cannot be used to build product numbers.

Accessory Product Numbers

SP	AS	240	AB4D	R
Power Break™ II Breaker				Extender
Device Type				R = Field installable kit
AS = Auxiliary switch ²				Blank = Factory installed
BAA = Bell alarm, alarm only ²				Auxiliary Switch Extender
BAL = Bell alarm with lockout ²				AB4 = Auxiliary switch, type AB with 4 elements
COUNTER = Mechanical counter ²				AB8 = Auxiliary switch, type AB with 8 elements
DIL = Defeatable door interlock				AB12 = Auxiliary switch, type AB with 12 elements
DOSD = Drawout secondary disconnects				(add suffix "D" for Drawout construction)
DOWB = Drawout mechanical interlock				Voltage, unless otherwise stated
DSS = Substructure shutter kit				012 = 12 Vdc
E = Electric operator ²				024 = 24 Vdc
HDOS = Hi-Break rated drawout substructure				048 = 48 Vdc
K4 = Kirk key lock (4 maximum) ²				120/125 = 120 Vac or 125 Vdc
PBCOVER = Pushbutton cover ²				240/250 = 240 Vac and 250 Vdc
RCS = Remote close solenoid ²				250 = 250 Vdc
SDOD = Standard rated drawout substructure				480 = 480 Vac
ST = Shunt trip ²				600 = 600 Vac
STL = Shunt trip with lockout ²				08 = 800 A 25 = 2500 A
UV = Undervoltage release				16 = 1600 A 30 = 3000 A
WB = Walking beam for stationery breakers				20 = 2000 A 40 = 4000 A
08 = 800A T-stud				BCA = Back connected aluminum
20 = 1600 thru 2000A T-stud				BCC = Back connected copper
S20 = 2000A T-stud (3000 frame)				FCA = Front connected aluminum terminal T-stud
S25 = 2500A T-stud				FCA = Front connected copper terminal T-stud
S30 = 3000A T-stud				LFCC = Front connected copper, long stud
S40 = 4000A T-stud				36B = 36 secondary disconnects, breaker
RAILS = Rail kit				36C = 36 secondary disconnects, substructure
LUGA = Lug adapter kit				
B = Enclosure				

²Device Product Number requires an extender "R" for field installable kit version only.

NOTE: This information is provided only for use interpreting product numbers. It cannot be used to build product numbers.



Low Voltage Power & Insulated Case Circuit Breakers Section 8

Power Break™ II Circuit Breakers

Product Number Nomenclature System

EntelliGuard™ TU Trip Unit Product Numbers

	Step 1	Step 2	Step 3	Step 4	Step 5	Step 6	Step 7	Step 8	Reserved	Reserved	Reserved	Reserved				
Trip Unit Form	G	B	2	0	4	L	5	C	5	X	R	X	X	X	X	Reserved
Power Break™ II													Reserved			
Frame Ratings													Reserved			
1600A													Reserved			
Sensor Rating													Reserved			
400A													Reserved			
OC and GF Protection Packages													Reserved			
LSIGA (S, switchable) (I, switchable ANSI only)													Reserved			
Zone Selective Interlocking													Original or Replacement Trip Unit			
ZSI, Short time and GF; user selectable													Replacement			
Advanced Features and Communications													Manual / Auto Trip Reset			
Monitoring + Relay Package + RELT													Not Selected			

Step 1 EntelliGuard™ Trip Unit Form

Character 1 & 2	Trip Unit Form
GA	PB1 (UL)
GB	PB2 (UL)

Step 2 Frame Ratings

Character 3	Frame Rating (amperes)	PowerBreak™ I / II
1	800A	•
2	1600A	•
3	2000A	•
4	2500A	•
5	3000A	•
6	3200A	•
7	4000A	•

Step 3 Sensor Rating (Amperes)

Character 4 & 5	Sensor Rating (Amperes)
02	200
04	400
08	800
10	1000
12	1200
14	
15	
16	1600
20	2000
25	2500
30	3000

Step 4 OC and GF Protection Packages

Character 6 & 7	Protection	PowerBreak™ I / II
L3	LSI (S, switchable) (I, Non-switchable)	•
L4	LSIG (S, switchable) (I, Non-switchable) (G, Non-Switchable Ground Fault Trip)	•
L5	LSIGA (S, switchable) (I, Non-switchable) (G, Non-Switchable Ground Fault Alarm)	•
L6	LSIC (S, switchable) (I, Non-switchable) (C, Non-Switchable External Ground Fault Trip)	
L7	LSICA (S, switchable) (I, Non-switchable) (C, Non-Switchable External Ground Fault Alarm)	
L8	LSIGDA* (S, G, A all switchable) (I, Non-switchable)	•
L9	LSIGCDA* (S, G, C, A all switchable) (I, Non-switchable)	

NOTE: All options include both the Circuit Break I²T and Fuse I⁴T curves



Low Voltage Power & Insulated Case Circuit Breakers Section 8

Power Break™ II Circuit Breakers

Product Number Nomenclature System

Step 5 Zone Selective Interlocking

Character 8	Zone Selective Interlocking	PowerBreak™ II
Z	ZSI, Short time and GF; user selectable	•
T	Z + IOC ZSI; user selectable	• ¹
X	NONE SELECTED	•

¹Instantaneous out only (used as a feeder).

Step 6 Advanced Features and Communications

Character 9	Features and Communications	PowerBreak™ II
1	RELT	•
2	Modbus Protocol + RELT	•
4	Monitoring + RELT	•
5	Monitoring + Relay Package + RELT	•
6	Monitoring + Data Acquisition, Modbus Protocol + RELT	•
X	NONE SELECTED	•
A ²	Modbus Protocol (W/O RELT)	•
B ²	Monitoring (W/O RELT)	•
C ²	Monitoring + Relay Package (W/O RELT)	•
D ²	Monitoring + Data Acquisition, Modbus Protocol (W/O RELT)	•
E ²	Monitoring + Data Acquisition + Relay Package, Modbus (W/O RELT)	•

²Options A - E are only available when output contact is needed for functions other than RELT

Step 7 Manual/Auto Trip Reset

Character 10	Manual/Auto Trip Reset	PowerBreak™ II
X	NONE SELECTED ³	•

³Feature not available for legacy breakers

Step 8 Original or Replacement Trip Unit

Character 11-15	Original or Replacement Trip Unit
RXXXX	Replacement trip unit (shipped loose)

EntelliGuard™ TU Trip Unit Rating Plug Product Numbers

	GTP	1100	U	12	25	
Trip Unit Type Rating						Largest Current Sensor Rating
GTP = Trip unit rating plug EntelliGuard™ TU Trip Unit						01 = 150 A
						16 = 1600 A
						02 = 200 A
						20 = 2000 A
						03 = 225 A
						25 = 2500 A
						04 = 400 A
						30 = 3000 A
						06 = 600 A
						32 = 3200 A
						07 = 630 A
						40 = 4000 A
						08 = 800 A
						50 = 5000 A
						10 = 1000 A
						60 = 6000 A
						12 = 1200 A
						64 = 6400 A
						13 = 1250 A
						Smallest Current Sensor Rating
						01 = 150 A
						16 = 1600 A
						02 = 200 A
						20 = 2000 A
						03 = 225 A
						25 = 2500 A
						04 = 400 A
						30 = 3000 A
						06 = 600 A
						32 = 3200 A
						07 = 630 A
						40 = 4000 A
						08 = 800 A
						50 = 5000 A
						10 = 1000 A
						60 = 6000 A
						12 = 1200 A
						64 = 6400 A
						13 = 1250 A
Rating Plug Ampere Rating						
0060 = 60 A	1000 = 1000 A					
0080 = 80 A	1100 = 1100 A					
0100 = 100 A	1200 = 1200 A					
0125 = 125 A	1500 = 1500 A					
0150 = 150 A	1600 = 1600 A					
0200 = 200 A	1700 = 1700 A					
0225 = 225 A	1800 = 1800 A					
0250 = 250 A	1900 = 1900 A					
0300 = 300 A	2000 = 2000 A					
0350 = 350 A	2200 = 2200 A					
0400 = 400 A	2400 = 2400 A					
0450 = 450 A	2500 = 2500 A					
0500 = 500 A	3000 = 3000 A					
0600 = 600 A	3200 = 3200 A					
0700 = 700 A	3600 = 3600 A					
0750 = 750 A	4000 = 4000 A					
0800 = 800 A	5000 = 5000 A					
0900 = 900 A	6000 = 6000 A					
Trip Unit Type						
U = Universal Trip Plug						



Low Voltage Power & Insulated Case Circuit Breakers Section 8

Power Break™ II Circuit Breakers

Product Number Nomenclature System

Power+ Trip Unit Product Numbers

	D2	20	LSI	T1	R¹	
Trip Unit Type and Rating						Replacement or New
D2 = Power Break™ II Power+ Trip Unit: 2000 A sensor maximum						R = Replacement trip unit (Blank) = New
D3 = Power Break™ II Power+ Trip Unit: 3000 A sensor maximum						
D4 = Power Break™ II Power+ Trip Unit: 4000 A sensor maximum						Trip unit options
						T1 = Target Module without ground fault target
						T2 = Target Module with ground fault target
						(Blank) = Factory Installed
Current Sensor Rating						Auxiliary functions
02 = 200 A 20 = 2000 A						LI = Long-time and Instantaneous
04 = 400 A 25 = 2500 A						LSI = Long-time, Short-time, Instantaneous
08 = 800 A 30 = 3000 A						
10 = 1000 A 40 = 4000 A						
16 = 1600 A						

¹Device Product Number requires an extender "R" for field installable kit version only.

NOTE: This information is provided only for use interpreting product numbers. It cannot be used to build product numbers.

Power+ Rating Plug Product Numbers

	TR	10	C	800	GF	
Trip Unit Type Rating						Ground Fault Function
TR = Trip unit rating plug All Power+, MicroVersaTrip™ Plus, and MicroVersaTrip™ PM rating plugs						Blank = No ground fault GF = Ground fault
Current Sensor Rating						Rating Plug Ampere Rating
02 = 200 A 20 = 2000 A						100 = 100 A 800 = 800 A
04 = 400 A 25 = 2500 A						150 = 150 A 1000 = 1000 A
08 = 800 A 30 = 3000 A						200 = 200 A 1100 = 1100 A
10 = 1000 A 40 = 4000 A						225 = 225 A 1200 = 1200 A
16 = 1600 A						250 = 250 A 1500 = 1500 A
						300 = 300 A 1600 = 1600 A
						400 = 400 A 2000 = 2000 A
						450 = 450 A 2500 = 2500 A
						500 = 500 A 3000 = 3000 A
						600 = 600 A 3600 = 3600 A
						700 = 700 A 4000 = 4000 A
Trip Unit Type						
C = Power+ trip unit rating plugs						

Power+ Target Module Product Numbers

TARGET00 = Blank insert for Target Module
 TARGET01 = Target Module without ground fault target
 TARGET02 = Target Module with ground fault target

NOTE: This information is provided only for use interpreting product numbers. It cannot be used to build product numbers.



Low Voltage Power & Insulated Case Circuit Breakers Section 8

Power Break™ II Circuit Breakers

Product Number Nomenclature System

MicroVersaTrip™ Plus and MicroVersaTrip™ PM Trip Unit Product Numbers

	B2	20	LSI	GZ1	PM	R ¹
Trip Unit Type and Rating						
B2 = Power Break™ II Enhanced MicroVersaTrip Plus™ or PM Trip Unit: 2000 A Sensor maximum						Remanufactured RM = Remanufactured Trip Unit RX = Exchanged Trip Unit
B3 = Power Break™ II Enhanced MicroVersaTrip Plus™ or PM Trip Unit: 3000 A Sensor maximum						
B4 = Power Break™ II Enhanced MicroVersaTrip Plus™ or PM Trip Unit: 4000 A Sensor maximum						
	Current Sensor Rating					
	02 = 200 A	20 = 2000 A				
	04 = 400 A	25 = 2500 A				
	08 = 800 A	30 = 3000 A				
	10 = 1000 A	40 = 4000 A				
	16 = 1600 A					
	Auxiliary Functions					
	LI = Long-time and instantaneous					
	LSI = Long-time, short-time, instantaneous					
	LSH = Long-time, short-time, high-range instantaneous					
						Trip Unit Options Options for MicroVersaTrip™ PM trip units only. Must select one: P = Protective relays & communications M = Metering & communications PM = Protective relays, metering, & communications (Blank) = MicroVersaTrip™ Plus trip unit
						Ground Fault Functions
						G = Ground fault
						GD = Ground fault defeatable (not UL listed)
						GZ1 = Ground fault; zone selective interlocking for ground fault only
						GZ2 = Ground fault and short-time selective interlock
						GDZ2 = Ground fault defeatable (not UL listed); ground fault and short-time selective interlock
						(Blank) = None

¹Device Product Number requires an extender "R" for field installable kit version only.

NOTE: This information is provided only for use interpreting product numbers. It cannot be used to build product numbers.

Rating Plug Product Numbers (MicroVersaTrip™ Plus and PM)

	TR	10	B	800	
Device Type					
TR = Trip unit rating plug All MicroVersaTrip™ Plus and MicroVersaTrip™ PM rating plugs					
					Rating Plug Ampere Rating
					100 = 100 A 1000 = 1000 A
					150 = 150 A 1200 = 1200 A
					200 = 200 A 1500 = 1500 A
					225 = 225 A 1600 = 1600 A
					300 = 300 A 2000 = 2000 A
					400 = 400 A 2500 = 2500 A
					500 = 500 A 3000 = 3000 A
					600 = 600 A 3600 = 3600 A
					700 = 700 A 4000 = 4000 A
					800 = 800 A
					Trip Unit Type B = All Enhanced MicroVersaTrip™ Plus and MicroVersaTrip™ PM trip unit rating plugs

NOTE: This information is provided only for use interpreting product numbers. It cannot be used to build product numbers.



Power Break™ II Circuit Breakers

Interrupting Capacity and Withstand Ratings

The interruption ratings and voltages shown in the table are maximum ratings. A circuit breaker of the type given in the left-hand column may be applied at the given circuit voltage in any electrical distribution system where the available fault current at the load terminals of the breaker does not exceed the value in the table. That circuit breaker type may also be applied at intermediate values of circuit voltage provided the available fault current at the load terminals of the breaker does not exceed the value in the table for the higher value of voltage.

Power Break™ II Interrupting Capacity and Short-time Ratings—rms Symmetrical kA

Frame	800A	1600 to 2000A	2500-3000A	4000A
UL 489 Ratings, 50/60 Hz Standard				
240V	65	85	100	100
480V	65	65	100	100
600V	42	50	85	85
Hi-Break				
240V	100	125	200	200
480V	100	100	150	150
600V	65	65	100	100
Short Time ¹				
(0.5 sec)	25	40	42	42
IEC-947-2 Ratings 415, 50/60 Hz				
I _{CU}	—	75	75 ²	85
I _{CS}	—	56	45 ²	25
I _{CW} (1 sec)	—	40	50 ²	50

¹Applies to high range instantaneous or "H" option.

²Must use 4000A construction.

Complete dimensions and weight information can be found in the Power Break™ II application guide GET-8052.

Stationary and Draw-out Switch Withstand Ratings—rms Symmetrical kA

Switch Frame (Amperes)	Short-time Rating, rms Sym Amperes @ 600 Vac Max., 500 ms Max.	Breaker Frame Size (Amperes)	Maximum Short Circuit Withstand Rating When Protected By Power Break™ II Circuit Breakers						Suitable on 200,000 rms Sym Ampere Fault Circuit When Protected by Class L Fuses As Follows	
			Standard Break PB II Circuit Breaker			Hi-Break PB II Circuit Breaker			Line Side Max. Fuse Ampere Rating	Load Side Max. Fuse Ampere Rating
			240 Vac	480 Vac	600 Vac	240 Vac	480 Vac	600 Vac		
800	30	800	65	65	50	100	100	65	2000	800
1600	40	1600	65	65	50	125	100	65	2500	1600
2000	40	2000	65	65	50	125	100	65	2500	2000
2500	42	2500	100	100	85	200	150	100	2500	2500
3000	42	3000	100	100	85	200	150	100	4000	3000
4000	42	4000	100	100	85	200	150	100	4000	4000



Low Voltage Power & Insulated Case Circuit Breakers Section 8

Power Break™ II Circuit Breakers

How To Order

How To Order

Power Break™ II's were previously ordered as separate product numbers for the Frame, Trip Unit, Accessories, etc. In 2008, they transitioned to a single 15 digit product number.

1. Determine your 15 digit number by using the BuyLog™ or the digitized configurator.
2. Check Elitenet for price and availability. Note: Because the number of possible combinations is in the millions, only product numbers that have been ordered are in EliteNet. If the number is not available in Elitenet, email the request to load the part to GE.1STOP_REPLY@GE.com
3. Once the product number is loaded and pricing finalized, the product can be ordered.
4. Note: Substructures/Cassettes, Neutral CT's, T-Studs, Drawout Secondary disconnects are ordered separately from the 15 digit number.



SSF20B220 Frame

Example—Stationary Breaker SSF3G6H2N001130

2000 ampere stationary frame, 65 kA, 480 V IC rating, 2000 ampere sensor, 800 ampere rating plug, trip unit functions including long-time (L), short-time (S), Instantaneous (I), EntelliGuard™ TU trip unit, field installed 120 Vac electric (motor) operator, 24 Vdc remote close solenoid, 24 Vdc undervoltage release module.

Note: See Power Break™ II Price Configurator, your GE Sales Representative, or call 1-800-GE1-STOP for pricing or any other information.



Draw-out in Substructure

Example—Draw-out Breaker SHD2B4X6K200130

1600 ampere draw-out frame, 100 kA, 480 V IC rating, 1000 ampere sensor, 600 ampere rating plug, trip unit functions including long-time (L), short-time (S), high range instantaneous (H), factory installed accessories including: 120 Vac electric (motor) operator; 24 Vdc remote close solenoid; 24 Vdc shunt trip; draw-out substructure; draw-out secondary disconnect; draw-out shutter.

Note: See Power Break™ II Price Configurator, your GE Sales Representative, or call 1-800-GE1-STOP for pricing or any other information.

Description	Product Number
Drawout Substructure	SPHDOS16
Substructure Secondary Disconnect	SPDOSD36S
Substructure Shutter Kit	SPDSS20



Power Break™ II Circuit Breakers

Frame Selection (Old Structure)



Basic Frame Selection—Stationary

Circuit Breaker Envelope Size (Amperes)	Circuit Breaker Frame Size (Amperes)	Current Sensor (Amperes)	Standard Break	Hi-Break
			Product Number ¹	Product Number ¹
800	800	200	SSF08*202,H	SHF08*202,H
		400	SSF08*204,H	SHF08*204,H
		800	SSF08*208,H	SHF08*208,H
1600	1600	800	SSF16*208,H	SHF16*208,H
		1000	SSF16*210,H	SHF16*210,H
		1600	SSF16*216,H	SHF16*216,H
2000	2000	2000	SSF20*220,H	SHF20*220,H
		1000	SSF25*210,H	SHF25*210,H
			SSB25*210,H	SHB25*210,H
		2000	SSF25*220,H	SHF25*220,H
			SSB25*220,H	SHB25*220,H
			SSF25*325,H	SHF25*325,H
3000	2500	2500	SSB25*325,H	SHB25*325,H
			SSF30*330,H	SHF30*330,H
			SSB30*330,H	SHB30*330,H
4000	4000	4000	SSF40*440 ²	SHF40*440 ³

Basic Frame Selection—Draw-out (without substructure)

Circuit Breaker Envelope Size (Amperes)	Circuit Breaker Frame Size (Amperes)	Current Sensor (Amperes)	Standard Break	Hi-Break
			Product Number ¹	Product Number ¹
800	800	200	SSD08*202,H	SHD08*202,H
		400	SSD08*204,H	SHD08*204,H
		800	SSD08*208,H	SHD08*208,H
1600	1600	800	SSD16*208,H	SHD16*208,H
		1000	SSD16*210,H	SHD16*210,H
		1600	SSD16*216,H	SHD16*216,H
2000	2000	2000	SSD20*220,H	SHD20*220,H
		1000	SSD25*210,H	SHD25*210,H
		2000	SSD25*220,H	SHD25*220,H
3000	2500	2500	SSD25*325,H	SHD25*325,H
			SSD30*330,H	SHD30*330,H
			SSD40*440,H	SHD40*440,H

¹Add 'H' suffix to product number for high-range instantaneous protection. High-range instantaneous feature available only with MicroVersaTrip™ Plus or MicroVersaTrip™ PM.

²80% rated.

*Replace * with B for MicroVersaTrip™ Plus or PM trip unit; or D for Power+™ trip unit.



Low Voltage Power & Insulated Case Circuit Breakers Section 8

Power Break™ II Circuit Breakers

Trip Unit Selection

How to Order

1. Determine the basic trip unit product number.
2. Determine the type of trip unit, EntelliGuard™ TU, Power+, MicroVersaTrip™ Plus or MicroVersaTrip™ PM trip unit.
3. Select the trip unit suffix representing the protection function to complete trip unit product number.
4. Order rating plug separately.

5. For replacement trip units, add suffix "R". Check Elitenet™ for List Price and GO schedule.

Example:

1600 Ampere frame, 1000 ampere sensor, Long-time (L). Short-time (S), Instantaneous (I), MicroVersaTrip™ PM with metering only. Order B210LSIM. The replacement trip unit product number would be B210LSIMR.

Power Break™ II Trip Unit Suffix Power+ Trip Unit Suffix Selection

Trip Unit Suffix ¹	Trip Indicators		Long-Time (L)	Short-Time (ST)	Inst. (I)
	L/ST/1 ¹	GF ²			
Adjustable	Instantaneous				
LI	—	—	•	—	•
LIT	•	—	•	—	•
LIT2	•	•	•	—	•
LSI	—	—	•	•	•
LSIT1	•	—	•	•	•
LSIT2	•	•	•	•	•

¹For high-range instantaneous or zone selective interlocking select MicroVersaTrip™ Plus or PM trip units.

²For ground fault-protection, select appropriate rating plug.

Basic Trip Unit Selection

Frame Size (Amperes)	Frame Rating (Amperes)	Sensor (Amperes)	EntelliGuard™ TU Trip Unit	Power+™ Trip Units	Enhanced MicroVersaTrip™ Plus and MicroVersaTrip™ PM Trip Units
800	800	200	GB102	D202	B202
		400	GB105	D204	B204
		800	GB108	D208	B208
1600-2000	1600	800	GB108	D208	B208
		1000	GB210	D210	B210
		1600	GB316	D216	B216
		2000	GB320	D220	B220
		1000	GB310	D210	B210
2500-3000	2500	2000	GB420	D220	B220
		2500	GB425	D325	B325
		3000	GB530	D330	B330
4000	4000	4000	GB740	D440	B440

EntelliGuard™ TU with Selectable Phase Ammeter - Trip Indicators Standard

Suffix 1 ¹	Overcurrent Protections	Trip Indicators	Selectable Phase Ammeter	Long-Time (L)	Long-Time with Fuse Settings (J)	Switchable Short-Time (ST)	Inst (I)	Ground Fault (G)	Ground Fault Alarm (GA)	GF/ST Zone Interlock (ZSI) ³
L3**	LSI (S, switchable)	•	•	•		•	•			opt.
L4**	LSIG (S, switchable)	•	•	•		•	•	•	•	opt.
L5**	LSIGA (S, switchable)	•	•	•		•	•	•	•	opt.
L8**	LSIGDA (GF/S, switchable) ²	•	•	•		•	•	•	•	opt.

¹Add suffix to basic trip unit to product number.

²Defeatable/Switchable Ground Fault, not UL Listed.

MicroVersaTrip™ Plus with Selectable Phase Ammeter—Trip Indicators Standard

Trip Unit Suffix ³	Trip Indicators	Selectable Phase Ammeter	Long-Time (L)	Short-Time (ST)	Inst. (I)	High Inst. (H)	Ground Fault (G) ⁴	GF Zone Interlock (Z1) ⁵	GF/ST Zone Interlock (Z2) ⁵
Adjustable Instantaneous									
LI	•	•	•		•				
LIG	•	•	•		•		•		
LIG Z1	•	•	•		•		•	•	
LSI	•	•	•	•	•				
LSIG	•	•	•	•	•		•		
LSIGZ1	•	•	•	•	•		•	•	
LSIGZ2	•	•	•	•	•		•		•
Fixed High Range Instantaneous⁶									
LSH	•	•	•	•		•			
LSHG	•	•	•	•		•	•		
LSHGZ1	•	•	•	•		•	•	•	
LSHGZ2	•	•	•	•		•	•		•

³Add suffix to basic trip unit product number.

⁴For single-phase 3 wire or 3-phase, 4-wire applications, order appropriate neutral current sensor separately, page 8-123. Defeatable Ground Fault (not UL Listed) is available. Use code GD in place of G.

⁵Requires purchase of Zone Selective Interlock module(s) Type TIM1 (120 Vac control voltage).

⁶Not available on 4000A stationary breaker frame.



Low Voltage Power & Insulated Case Circuit Breakers Section 8

Power Break™ II Circuit Breakers

Trip Unit Selection

MicroVersaTrip™ PM with Metering and Communications—Trip Indicators Standard

Trip Unit Suffix ¹	Trip Indicators	Selectable Phase Ammeter	Long-Time (L)	Short-Time (ST)	Inst. (I)	High Inst. (H)	Ground Fault (G) ²	GF Zone Interlock (Z1) ³	GF/ST Zone Interlock (Z2) ³
Adjustable Instantaneous									
LIM	•	•	•		•				
LIGM	•	•	•		•				
LIGZ1M	•	•	•		•			•	
LSIM	•	•	•	•					
LSIGM	•	•	•	•					
LSIGZ1M	•	•	•	•				•	
LSIGZ2M	•	•	•	•					•
Fixed High Range Instantaneous⁴									
LSHM	•	•	•						
LSHGM	•	•	•						
LSHGZ1M	•	•	•					•	
LSHGZ2M	•	•	•						•

MicroVersaTrip™ PM with Protective Relays and Communications—Trip Indicators Standard

Trip Unit Suffix ¹	Trip Indicators	Selectable Phase Ammeter	Long-Time (L)	Short-Time (ST)	Inst. (I)	High Inst. (H)	Ground Fault (G) ²	GF Zone Interlock (Z1) ³	GF/ST Zone Interlock (Z2) ³
Adjustable Instantaneous									
LIP	•	•	•		•				
LIGP	•	•	•		•				
LIGZ1P	•	•	•		•			•	
LSIP	•	•	•	•					
LSIGP	•	•	•	•					
LSIGZ1P	•	•	•	•				•	
LSIGZ2P	•	•	•	•					•
Fixed High Range Instantaneous⁴									
LSHP	•	•	•						
LSHGP	•	•	•						
LSHGZ1P	•	•	•					•	
LSHGZ2P	•	•	•						•

MicroVersaTrip™ PM with Metering, Protective Relays and Communications—Trip Indicators Standard

Trip Unit Suffix ¹	Trip Indicators	Selectable Phase Ammeter	Long-Time (L)	Short-Time (ST)	Inst. (I)	High Inst. (H)	Ground Fault (G) ²	GF Zone Interlock (Z1) ³	GF/ST Zone Interlock (Z2) ³
Adjustable Instantaneous									
LIPM	•	•	•		•				
LIGPM	•	•	•		•				
LIGZ1PM	•	•	•		•			•	
LSIPM	•	•	•	•					
LSIGPM	•	•	•	•					
LSIGZ1PM	•	•	•	•				•	
LSIGZ2PM	•	•	•	•					•
Fixed High Range Instantaneous⁴									
LSHPM	•	•	•						
LSHGPM	•	•	•						
LSHGZ1PM	•	•	•					•	
LSHGZ2PM	•	•	•						•

¹Add suffix to basic trip unit product number.

²For single-phase 3 wire or 3-phase, 4-wire applications, order appropriate neutral current sensor separately, page 8-123. Defeatable Ground Fault (not UL Listed) is available. Use code GD in place of G.

³Requires purchase of Zone Selective Interlock module(s) Type TIM1 (120 Vac control voltage).

⁴Not available on 4000A stationary breaker frame.



Low Voltage Power & Insulated Case Circuit Breakers Section 8

Power Break™ II Circuit Breakers

Enhanced MicroVersaTrip™, Rating Plug Selection

Power Break™ II Rating Plug Selection

Frame Size (Amperes)	Sensor Rating (Amperes)	Current Rating (Amperes)	Power+ Trip Unit Standard Rating Plugs	Power+ Trip Unit Ground Fault Rating Plugs	Enhanced MicroVersaTrip™ Plus and Enhanced MicroVersaTrip™ PM Trip Unit Rating Plugs		EntelliGuard™ TU Trip Unit Rating Plugs	
					MicroVersaTrip™ Plus	MicroVersaTrip™ PM		
800	200	100	TR2C100	TR2C100GF	TR2B100	GTP0100U0103		
		150	TR2C150	TR2C150GF	TR2B150	GTP0150U0104		
		200	TR2C200	TR2C200GF	TR2B200	GTP0200U0204		
	400	150	-	-	TR4B150	GTP0150U0104		
		200	TR4C200	TR4C200GF	TR4B200	GTP0200U0204		
		225	TR4C225	TR4C225GF	TR4B225	GTP0225U0306		
		250	TR4C250	TR4C250GF	TR4B250	GTP0250U0407		
		300	TR4C300	TR4C300GF	TR4B300	GTP0300U0408		
		400	TR4C400	TR4C400GF	TR4B400	GTP0400U0410		
800-1600	800	300	-	-	TR8B300	GTP0300U0408		
		400	TR8C400	TR8C400GF	TR8B400	GTP0400U0410		
		450	TR8C450	TR8C450GF	TR8B450	GTP0450U0612		
		500	TR8C500	TR8C500GF	TR8B500	GTP0500U0613		
		600	TR8C600	TR8C600GF	TR8B600	GTP0600U0616		
		700	TR8C700	TR8C700GF	TR8B700	GTP0700U0816		
		800	TR8C800	TR8C800GF	TR8B800	GTP0800U0820		
		400	-	-	TR10B400	GTP0400U0410		
		600	TR10C600	TR10C600GF	TR10B600	GTP0600U0616		
1600	1000	800	TR10C800	TR10C800GF	TR10B800	GTP0800U0820		
		1000	TR10C1000	TR10C1000GF	TR10B1000	GTP1000U1025		
		600	-	-	TR16B600	GTP0600U0616		
	1600	800	TR16C800	TR16C800GF	TR16B800	GTP0800U0820		
		1000	TR16C1000	TR16C1000GF	TR16B1000	GTP1000U1025		
		1100	TR16C1100	TR16C1100GF	TR16B1100	GTP1100U1225		
		1200	TR16C1200	TR16C1200GF	TR16B1200	GTP1200U1232		
		1600	TR16C1600	TR16C1600GF	TR16B1600	GTP1600U1640		
		750	-	-	TR20B750	GTP0750U0820		
2000	2000	800	-	-	TR20B800	GTP0800U0820		
		1000	TR20C1000	TR20C1000GF	TR20B1000	GTP1000U1025		
		1200	TR20C1200	TR20C1200GF	TR20B1200	GTP1200U1232		
		1500	TR20C1500	TR20C1500GF	TR20B1500	GTP1500U1640		
		1600	TR20C1600	TR20C1600GF	TR20B1600	GTP1600U1640		
		2000	TR20C2000	TR20C2000GF	TR20B2000	GTP2000U2050		
		400	-	-	TR10B400	GTP0400U0410		
		2500	1000	600	TR10C600	TR10C600GF	TR10B600	GTP0600U0616
				800	TR10C800	TR10C800GF	TR10B800	GTP0800U0820
1000	TR10C1000			TR10C1000GF	TR10B1000	GTP1000U1025		
2000	750		-	-	TR20B750	GTP0750U0820		
	800		-	-	TR20B800	GTP0800U0820		
	1000		TR20C1000	TR20C1000GF	TR20B1000	GTP1000U1025		
	1200		TR20C1200	TR20C1200GF	TR20B1200	GTP1200U1232		
	1500		TR20C1500	TR20C1500GF	TR20B1500	GTP1500U1640		
	1600		TR20C1600	TR20C1600GF	TR20B1600	GTP1600U1640		
3000	2000	2000	TR20C2000	TR20C2000GF	TR20B2000	GTP2000U2050		
		1600	TR25C1600	TR25C1600GF	TR25B1600	GTP1600U1640		
		2500	TR25C2500	TR25C2500GF	TR25B2500	GTP2500U2564		
	2500	2500	TR25C2500	TR25C2500GF	TR25B2500	GTP2500U2564		
		1200	TR30C1200	TR30C1200GF	TR30B1200	GTP1200U1232		
		1600	TR30C1600	TR30C1600GF	TR30B1600	GTP1600U1640		
		2000	TR30C2000	TR30C2000GF	TR30B2000	GTP2000U2050		
		2500	TR30C2500	TR30C2500GF	TR30B2500	GTP2500U2564		
		3000	TR30C3000	TR30C3000GF	TR30B3000	GTP3000U3064		
4000	3000	1600	TR40C1600	TR40C1600GF	TR40B1600	GTP1600U1640		
		2000	TR40C2000	TR40C2000GF	TR40B2000	GTP2000U2050		
		2500	TR40C2500	TR40C2500GF	TR40B2500	GTP2500U2564		
	4000	3000	TR40C3000	TR40C3000GF	TR40B3000	GTP3000U3064		
		3600	TR40C3600	TR40C3600GF	TR40B3600	GTP3600U4064		
		4000	TR40C4000	TR40C4000GF	TR40B4000	GTP4000U4064		



MicroVersaTrip™ and MicroVersaTrip™ PM Rating Plug



Power+ Trip Target Module



EntelliGuard™ TU Rating Plug

Power+ Target Module

Power+ trip units are designed to accept an optional field-installable target module. The target module indicates long-time pickup, battery status, trip unit health status, and whether a breaker trip was caused by an overload, a short circuit or a ground fault. Target modules are available with or without ground fault indication.

L/ST/1	Trip Indicator		Product Number
	Ground Fault		
-	-	-	TARGET00
•	•	-	TARGET01
•	•	•	TARGET02



Low Voltage Power & Insulated Case Circuit Breakers Section 8

Power Break™ II Molded Case Switch

Old Product Numbers — Stationary and Draw-out Switch Selection

How to Order

1. Choose a frame from the Molded Case Switch Frame tables below
2. Select a Control Unit from the Control Unit table below. The sensor rating of the control unit should match the sensor rating of the switch. Choose a control unit with suffix T2 to get ground fault target indication.
3. Select a rating plug from the table to the right.
4. Select all other accessories just as for any Power Break™ II Circuit Breaker.

Molded Case Switch Frames—Stationary

Switch Envelope Size (Amperes)	Switch Frame Size (Amperes)	Current Sensor Rating (Amperes)	Product Number
800	800	800	SSF08Y208
1600	1600	1600	SSF16Y216
2000	2000	2000	SSF20Y220
3000	2500	2500	SSF25Y325
		2500	SSB25Y325
	3000	3000	SSF30Y330
			SSB30Y330

Molded Case Switch Frames—Draw-out¹

Switch Envelope Size (Amperes)	Switch Frame Size (Amperes)	Current Sensor Rating (Amperes)	Product Number
800	800	800	SSD08Y208
1600	1600	1600	SSD16Y216
2000	2000	2000	SSD20Y220
3000	2500	2500	SSD25Y325
	3000	3000	SSD30Y330
4000	4000	4000	SSD40Y440

¹Use only with Hi-Break draw-out substructure.

Control Units

Switch Envelope Size (Amperes)	Switch Frame Size (Amperes)	Sensor (Amperes)	Product Number
800	800	800	D208
			D208T2
1600	1600	1000	D210
			D210T2
		1600	D216
			D216T2
2000	2000	2000	D220
			D220T2
3000	2500	1000	D210
			D210T2
			D220
	2000	D220T2	
	2500	D325	
		D325T2	
4000	4000	3000	D330
			D330T2
			D440
			D440T2

Power Break™ II Rating Plug Selection

Basic Control Unit	Current Rating (Amperes)	Power + Standard Rating Plug	Power + Ground Fault Rating Plug
D208	800	TR8C800	TR8C800GF
D210	1000	TR10C1000	TR10C1000GF
D216	1600	TR16C1600	TR16C1600GF
D220	2000	TR20C2000	TR20C2000GF
D325	2500	TR25C2500	TR25C2500GF
D330	3000	TR30C3000	TR30C3000GF
D440	4000	TR40C4000	TR40C4000GF

Ordering Example SSD2Y4A2H200220

1600 ampere drawout switch; factory installed 240 Vac electric (motor) operator; 240 Vac remote close solenoid; 24 Vac/DC shunt trip; drawout substructure; drawout secondary disconnect; drawout shutter.

Note: See Power Break™ II updated nomenclature on page 8-99 for product number and see Power Break™ II configurator for pricing. Contact sales representative for configurator.



Low Voltage Power & Insulated Case Circuit Breakers Section 8

Power Break™ II Circuit Breakers

Stationary and Draw-out Breaker Accessories

All devices UL Listed for factory or field installation except where noted.

Accessories—Stationary and Draw-out Breakers

The complete line of Power Break™ II breaker accessories may be either factory or field installed to meet user needs. The electronic shunt trip, the bell alarm, the bell alarm with mechanical lockout, and the undervoltage release modules are drop-in from the front of the breaker, interchangeable across all frames, and require no field internal wiring or breaker disassembly. Auxiliary switch modules are available in groups of 4, 8 or 12, NO/NC single-pole, double-throw (SPDT) switches. Their installation simply involves removal of breaker cover, installation of the switch module, routing of wiring and installation of the pre-wired terminal block and re-installation of the cover. Auxiliary switches are also interchangeable across all Power Break™ II breaker frames.

Electrical Operator

The electrical operator mounts inside the front cover of the manually operated breaker. This accessory can be added to any Power Break™ II breaker in the factory or the field to provide electrical spring charging and charge indication. **For remote closing, the remote close solenoid must be ordered separately.** All breakers are prewired to dedicated secondary terminals for easy field installation. When electrical operation is used, either a shunt trip or an undervoltage release must be ordered separately.

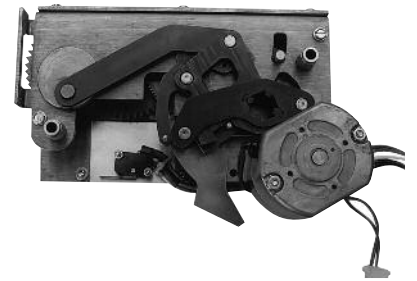

Electrical Operator

Ratings Vac	Ratings Vdc	Field Installable Product Number	Factory Installed Product Number
120	-	SPE120R	SPE120
240	-	SPE240R	SPE240
-	24	SPE024R	SPE024
-	48	SPE048R	SPE048
-	72	SPE072R	SPE072
-	125	SPE125R	SPE125

Remote Close Solenoid

This accessory provides an electrically operated solenoid which, when energized, closes the breaker. It is suitable for control interlock schemes in which manual closing capability would not be convenient or desirable. The breaker is provided with a manual close button, which can be replaced by the Hidden "ON" Button accessory and/or sealed using the Limited Access Pushbutton Cover accessory. The remote close accessory is continuously rated and has an anti-pump feature, which prevents a motor operated breaker from repeatedly closing into a fault. Closing control voltage must be removed and re-applied for each breaker closure.

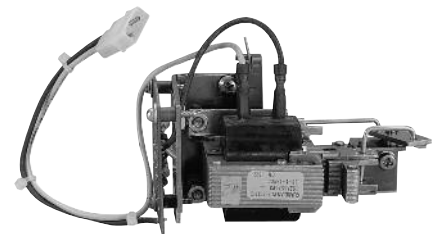

Remote Close Solenoid

Ratings Vac	Ratings Vdc	Field Installable Product Number	Factory Installed Product Number
120	-	SPRCS120R	SPRCS120
240	-	SPRCS240R	SPRCS240
-	24	SPRCS024R	SPRCS024
-	48	SPRCS048R	SPRCS048
-	72	SPRCS072R	SPRCS072
-	125	SPRCS125R	SPRCS125



Low Voltage Power & Insulated Case Circuit Breakers Section 8

Power Break™ II Circuit Breakers

Stationary and Draw-out Breaker Accessories

All devices UL Listed for factory or field installation except where noted.

Shunt Trip

The shunt trip accessory is an electronic module, which provides remote control capability to open the circuit breaker. When activated, the shunt trip module sends a signal to the trip unit to open the breaker. This allows the trip unit to record, display, distinguish and communicate (in MicroVersaTrip™ PM trip units) that the opening event was initiated by the shunt trip device. The shunt trip is continuously rated and requires no cut-off switch. When energized, the shunt trip supplies +24Vdc power to the trip unit to power the display.



Shunt Trip Module

Ratings Vac	Ratings Vdc	Field Installable Product Number	Factory Installed Product Number
-	12	SPST012R	SPST012
24	24	SPST024R	SPST024
48	48	SPST048R	SPST048
120	125	SPST120R	SPST120
208	-	SPST208R	SPST208
240	250	SPST240R	SPST240
480	-	SPST480R ¹	SPST480 ¹
600	-	SPST600R ¹	SPST600 ¹

¹Kit contains externally mounted transformer.

Shunt Trip with Lockout Module

The shunt trip with lockout is identical to the regular shunt trip, but when energized, it will also prevent closure of an "open" breaker by mechanically blocking both manual and electrical closing. When energized, the closing springs will not discharge, the movable contacts will not move; the contacts are "kiss free."

Ratings Vac	Ratings Vdc	Field Installable Product Number	Factory Installed Product Number
-	12	SPSTL012R	SPSTL012
24	24	SPSTL024R	SPSTL024
48	48	SPSTL048R	SPSTL048
120	125	SPSTL120R	SPSTL120
208	-	SPSTL208R	SPSTL208
240	250	SPSTL240R	SPSTL240
480	-	SPSTL480R ¹	SPSTL480
600	-	SPSTL600R ¹	SPSTL600

¹Kit contains externally mounted transformer.



Low Voltage Power & Insulated Case Circuit Breakers Section 8

Power Break™ II Circuit Breakers

Stationary and Draw-out Breaker Accessories

All devices UL Listed for factory or field installation except where noted.

Undervoltage Release Module

The undervoltage release is an electronic module used to open the circuit breaker when the monitored voltage drops below 35-60% of its rated value. The undervoltage release "resets" when the monitored voltage is re-established allowing the circuit breaker to re-close (the sealing voltage of the UVR is 60-85% of its rated voltage).

An undervoltage release trip operation is produced by the MicroVersaTrip™ Plus unit in response to a signal from the undervoltage release module. This allows the trip unit to record, display, distinguish and communicate (in MicroVersaTrip™ PM trip units) that the breaker opening event was due to undervoltage release. Operation of the undervoltage release module will prevent breaker contact closure, i.e. "kiss-free" operation. When energized, the undervoltage release supplies +24 Vdc power to the trip unit to power the display.



Undervoltage Release Module

Ratings Vac	Ratings Vdc	Field Installable Product Number	Factory Installed Product Number
24	-	SPUV024ACR	SPUV024AC
48	-	SPUV048ACR	SPUV048AC
120	-	SPUV120ACR	SPUV120AC
208	-	SPUV208ACR	SPUV208AC
240	-	SPUV240ACR	SPUV240AC
480	-	SPUV480ACR ¹	SPUV480AC ¹
600	-	SPUV600ACR ¹	SPUV600AC ¹
-	12	SPUV012DCR	SPUV012DC
-	24	SPUV024DCR	SPUV024DC
-	48	SPUV048DCR	SPUV048DC
-	125	SPUV125DCR	SPUV125DC
-	250	SPUV250DCR	SPUV250DC

¹Kit contains externally mounted transformer.

Time Delay Module for UVR

The time delay module prevents nuisance tripping due to momentary loss of voltage. The module has 120 Vac input and 125 Vdc output and must be used with the 125 Vdc UVR.

Description	Product Number
Time Delay Module (0.1 to 1.0 second delay)	SPUVTD

Bell Alarm (Alarm Only)

The bell alarm module is used to signal breaker "tripped" status to other accessories (e.g., external alarm devices, indicating lights, relays, or logic circuits) for remote indication and interlocking functions. The bell alarm response is configurable by means of rear-mounted DIP switches on the trip unit. The bell alarm can be made to operate in response to an overcurrent (including ground fault) or protective relay trip and/or a shunt trip operation, and/or operation of the undervoltage release module. It is not actuated as a result of normal breaker "ON/OFF" operation.

This module provides a visual, mechanical pop-out target, which protrudes through the face of the circuit breaker door when it operates. The bell alarm may be reset manually by depressing the mechanical target, or automatically by closing the breaker.

The bell alarm is provided with one SPDT switch with control power duty contacts as shown in the auxiliary switch accessories.



Bell (Alarm Only)

Ratings Vac	Ratings Vdc	Field Installable Product Number	Factory Installed Product Number
240	125-250	SPBAA240R	SPBAA240
600	125-250	SPBAA600R ¹	SPBAA600 ¹

¹600 Vac module not UL Listed.



Low Voltage Power & Insulated Case Circuit Breakers Section 8

Power Break™ II Circuit Breakers

Stationary and Draw-out Breaker Accessories

All devices UL Listed for factory or field installation except where noted.

Bell Alarm With Lockout

The bell alarm with lockout module combines both the bell alarm and a manual lockout function. The bell alarm switch operates identically to the standard bell alarm module, except that the mechanical pop-out target must be manually reset before the breaker can be closed.

Operation of the bell alarm with lockout module can be independently set by means of setting the DIP switches at the rear of the trip unit. Current rating of the single SPDT switch is identical to the auxiliary switch accessories.

Ratings Vac	Ratings Vdc	Field Installable Product Number	Factory Installed Product Number
240	125-250	SPBAL240R	SPBAL240
600	125-250	SPBAL600R ¹	SPBAL600 ¹

¹600 Vac module not UL Listed.



Bell Alarm with Mechanical Reset Lockout

Auxiliary Switch

An auxiliary switch signals the circuit breaker's primary contact position (i.e., OPEN or CLOSED) to other devices, such as indicating lights, relays or logic circuits. This enables the user to provide remote indication, interlocking or control operations as a function of breaker primary contact position. The auxiliary switch operation is independent of the method by which the breaker is opened or closed. The auxiliary switch does not distinguish between a "tripped" or "open" condition. The auxiliary switch contacts follow the main breaker contacts on opening and precede them on closing.

Auxiliary switch modules are available with 4, 8 or 12 NO/NC (SPDT) switches for control power duty ac/dc ratings. When ordered for field installation, an auxiliary switch module comes pre-wired to its own terminal board, which mounts with one screw to the left of the breaker. A special accessory, available for draw out breakers, comes pre-wired to the breaker secondary disconnect. All switch ratings are 6A at 120V-600 Vac, 1/2A at 125 Vdc and 1/4A at 250 Vdc.

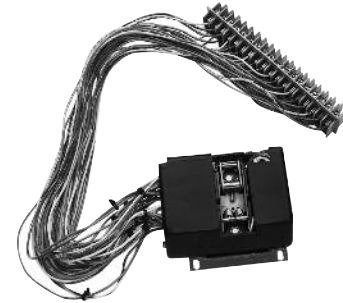

Auxiliary Switch with Pre-wired Secondary Terminals for Stationary Breaker

Auxiliary Switches for Stationary Breakers

Ratings Vac	Ratings Vdc	No. of SPDT Switch Elements (Contacts)	Field Installable Product Number	Factory Installed Product Number
240	125-250	4	SPAS240AB4R	SPAS240AB4
240	125-250	8	SPAS240AB8R	SPAS240AB8
240	125-250	12	SPAS240AB12R	SPAS240AB12
600	125-250	4	SPAS600AB4R ¹	SPAS600AB4 ¹
600	125-250	8	SPAS600AB8R ¹	SPAS600AB8 ¹

¹600 Vac module not UL Listed.

Auxiliary Switches for Draw-out Breakers

Ratings Vac	Ratings Vdc	No. of SPDT Switch Elements (Contacts)	Field Installable Product Number	Factory Installed Product Number
240	125-250	4	SPAS240AB4DR	SPAS240AB4D
240	125-250	8	SPAS240AB8DR	SPAS240AB8D
240	125-250	12	SPAS240AB12DR	SPAS240AB12D
600	125-250	4	SPAS600AB4DR ¹	SPAS600AB4D ¹
600	125-250	8	SPAS600AB8DR ¹	SPAS600AB8D ¹

¹600 Vac module not UL Listed.

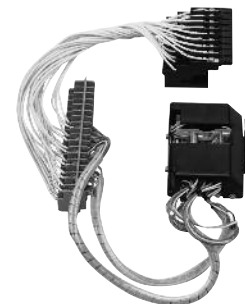

Auxiliary Switch with Pre-wired Secondary Terminals for Draw-out Breaker



Low Voltage Power & Insulated Case Circuit Breakers Section 8

Power Break™ II Circuit Breakers

Stationary and Draw-out Breaker Accessories

All devices UL Listed for factory or field installation except where noted.

Mechanical Operations Counter

The mechanical operations counter is mounted behind the front cover of the breaker. It is viewable through a rectangular knockout window opening in the breaker cover. It is a five-digit, non-resettable counter, which is actuated each time the breaker is opened by any means.

Field Installed Product Number	Factory Installed Product Number
SPCOUNTER	SPCOUNTER



Mechanical Operations Counter

Limited Access Pushbutton Cover

This accessory limits access to "ON/OFF" control of a breaker to authorized personnel. The pushbutton cover accessory consists of transparent hinged covers that can be individually sealed to the limited access assembly. Both the "ON" and "OFF" buttons can be pilot drilled to allow use of a 1/8" rod to operate either one or both pushbuttons.

Field Installed Product Number	Factory Installed Product Number
SPPBCOVER	SPPBCOVER



Breaker with limited access pushbutton cover assembly installed

Hidden "ON" Button

The hidden "ON" button is assembled to the mechanism behind an unlabeled, false pushbutton. Manual closing of the breaker can only be performed by means of a small diameter rod. This accessory is used to limit access to the manual "ON" control to authorized personnel.

Field Installed Product Number	Factory Installed Product Number
SPPBNOR	SPPBNON



Activating the breaker closing mechanism through the hole in the Hidden "ON" Button

Maintenance/Repair Parts

Description	Product Number
Top Cover and Rating Labels	SPBICOVER ¹
Replacement MVT Door	10054335P1
Replacement Powerplus Door	10054335P2
Stop Block Kit w/Installation Tool	SPBUMPERKIT
Visible "On" Button Conversion	SPPBRONR
PB1 SM FR Door Interlock/Padlock	TSPL
800A PB1 to PB2 Stationary Retrofit Kit	SSF08TPCCR ²
1600A PB1 to PB2 Stationary Retrofit Kit	SSF16TPCCR ²
2000A PB1 to PB2 Stationary Retrofit Kit	SSF20TPCCR ²
2500A-4000A PB1 to PB2 Stationary Retrofit Kit	SSF40TPCCMR ³
2500A-4000A PB1 to PB2 Stationary Retrofit Kit	SSF40TPCCR ⁴
Replacement Breaker Secondary Disconnect	SPDOSD36B

¹Special handling and order entry required to preserve UL Listing of breaker.

Contact Post Sale Service for additional details of special process.

²Manually or electrically operated

³Manually operated

⁴Electrically Operated



Low Voltage Power & Insulated Case Circuit Breakers Section 8

Power Break™ II Circuit Breakers

Stationary and Draw-out Breaker Accessories

All devices UL Listed for factory or field installation except where noted.

Key Interlock Provisions

The key interlock provision enables the user to mount a one- to four-cylinder, narrow-faced, Kirk-type FN or Superior customer-supplied lock on the face of the breaker. This accessory provides mounting for key interlocks that are furnished by the customer. The key interlock provision works in conjunction with the padlock provision. The key interlock extends a lever through the padlock hasp when the key is turned to the key removal or bolt extended position. Additionally, the accessory provides a hasp for mounting three padlocks with 1/4" to 3/8" diameter shanks.

Key Interlock Reference Table

Product Number	Number of Locks	Kirk Key Lock Product Number	Superior Product Number
SPK4	1	KFN00001 ¹	S105827Y
SPK4	2	KFN00002 ¹	S105828Y
SPK4	3	KFN00003 ¹	S105829Y
SPK4	4	KFN00004 ¹	S105827-4Y

¹Final digit may be 0, 1, 2 or 3 depending on number of key removal positions.

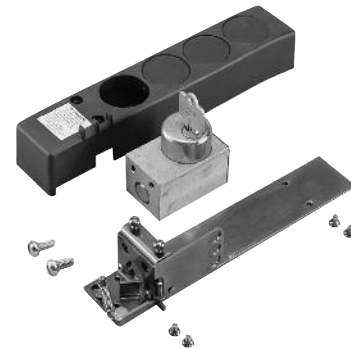

Key Interlock Kit (lock not included)

Product Numbers, Key Interlock Provisions

Circuit Breaker Envelope Size (Amps)	Number of Key Locks	Field Installed Product Number	Factory Installed Product Number
All	1 to 4	SPK4R	SPK4

Door Interlock

The door interlock provides interlocking of the circuit breaker compartment's hinged door so that the breaker must be in the "OFF" position before the door can be opened. The door interlock is defeatable with a small tool to allow authorized access.

Field Installed Product Number	Factory Installed Product Number
SPDILR	SPDIL

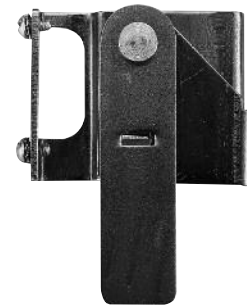

Door Interlock

Padlock Provisions (Standard)

Padlocking provisions are standard on all Power Break™ II circuit breakers. When the breaker is in the open position, and the padlock hasp is raised at least 1/4", the breaker cannot be closed mechanically or electrically. The hasp accepts up to three padlocks with 1/4" to 3/8" diameter shanks.

Walking Beam Interlocks—Stationary Breakers Only

Walking beam interlocks are mechanical devices used to prevent two adjacent circuit breakers from both being in the "ON" or closed position at the same time. However, both breakers can be in the "OFF" or open position. Adjacent circuit breakers can be laterally or vertically mounted.

Circuit Breaker Envelope Size (Amperes)	Product Number
800, 1600 and 2000	SPWB20
3000	SPWB30
4000	SPWB40



Low Voltage Power & Insulated Case Circuit Breakers Section 8

Power Break™ II Circuit Breakers

Stationary Breaker Mounting Kits

All devices UL Listed for factory or field installation except where noted.

Lug Adapter Kits

Kits pre-mount to bus structure allowing cabling or bussing to be completed prior to breaker mounting. Accepts either lugs or crimp-type connector terminals. Kit includes adapter and hardware for either a three-pole line-side, or a three-pole load-side connection. (Lugs not included).

Frame Rating (Amperes)	Product Number	Suitable for use with up to:
800	TPLUGA08	3 TPLUG108 Lugs or 3 crimp Lugs ¹ per pole
1600	TPLUGA16 ²	6 TPLUG108 lugs or 6 crimp Lugs ¹ per pole
2000	SPLUGA20 ³	6 TPLUG108 Lugs or 6 crimp Lugs ¹ per pole

¹Anderson No. VCEL-075-12H1 or equivalent

²T-Studs - TP16FCA - included with adapter

³T-Studs - SP20FCA - included with adapter

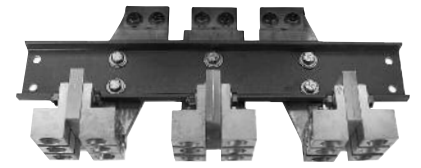

2000 Ampere Power Break™ II breaker with SPLUGA20 lug adapter kit and 18 lugs (TPLUG108)

Lug Kits

Kits accept Cu/Al wire and are suitable for direct mounting to the breaker. When ordering Type TPLUG kits, order one kit per line or load pole. Example: A complete set of lugs for the line side of an 800A frame, 400A trip breaker would be Qty 3-TPLUG106 lugs.

When ordering TSLUG kits order one kit per line or load side; TSLUG kits require use of T-studs. Example: A complete set of lugs for a 3000A frame, 2500A trip breaker would be Qty 1-TSLUG25. T-Studs would also be required.

Circuit Breaker Envelope Size (Amperes)	Max Rating (Amperes)	Product Number	Lug Per Kit	Max. Cables Per Pole	Wire Range kcmil Cu/Al
800	400	TPLUG106	1	1	(2) #2 2-600
	600	TPLUG206	1	2	(2) #2 2-600
	800	TPLUG308	1	3	(3) 300-750
	800	TPLUG108 ⁴	1	3	3/0-800
1600	800	TPLUG108 ⁴	1	6	3/0-800
	1600	TPLUG408	1	4	500-800
	2000	TPLUG108 ⁴	1	6	3/0-800
2000	800	TSLUG08	9	3	3/0-800
	1200	TSLUG12	12	4	3/0-800
	1600	TSLUG16	15	5	3/0-800
	2000	TSLUG20	18	6	3/0-800
3000	2500	TSLUG25	21	7	3/0-800
	3000	TSLUG30	27	9	3/0-800
	4000	TSLUG40	27	9	3/0-800

⁴For use with adapter kit only. See table above.



Type TPLUG206



Type TPLUG408



Type TPLUG308

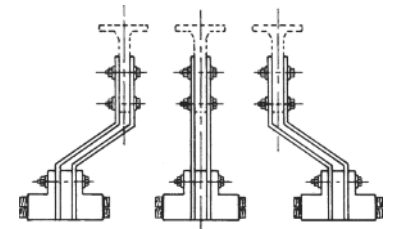

Type TSLUG20



Low Voltage Power & Insulated Case Circuit Breakers Section 8

Power Break™ II Circuit Breakers

Stationary Breaker Mounting Kits, Wall Mounted Enclosures, Floor Mounted Enclosures

All devices UL Listed for factory or field installation except where noted.

T-Studs

T-studs mount directly to the breaker, and can be rotated for either vertical or horizontal bus connection. 4000 ampere T-studs are for vertical bus bars only. Product number includes one stud. Both copper and aluminum T-studs are tin-plated.

T-Studs—Front Connected Breaker

Circuit Breaker Frame Size (Amperes)	Max. Rating (Amperes)	Product Number
800	800	SP08FCA ¹
800	800	SP08FCC ²
1600, 2000	2000	SP20FCA ¹
1600, 2000	2000	SP20FCC ²
2500	2000	SPS20FCA ¹
2500	2500	SPS25FCC ²
3000	3000	SPS30FCC ²
4000	4000	SPS40FCC ²
4000	4000	SPS40LFCC ^{2,3}

T-Studs—Back Connected Breaker

Circuit Breaker Frame Size (Amperes)	Max. Rating (Amperes)	Product Number
2500	2000	SPS20BCA ^{1,4}
2500	2500	SPS25BCC ²
3000	3000	2,4

¹Aluminum

²Copper

³Extra long stud. Alternate with SPS40FCC for ease of installation.

⁴Supplied with integral T-stud

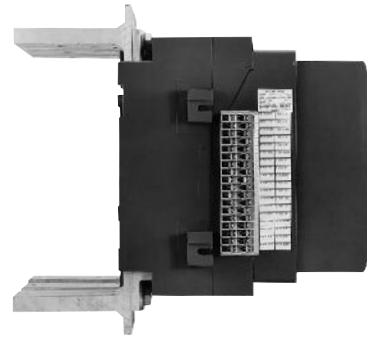

2000A Breaker with "T" Studs Mounted

Trimplate

Factory Installed Product Number	Field Installable Product Number
SPTRIMPLATE	SPTRIMPLATER



Low Voltage Power & Insulated Case Circuit Breakers Section 8

Power Break™ II Circuit Breakers

Neutral Current Sensors and POWER LEADER Accessories

Neutral Current Sensors¹

Breaker Frame (Amperes)	Circuit Breaker Sensor Rating (Amperes)	Neutral Sensor Rating or Tap Settings (Amperes)	Product Number
800	200	200	TSVG302
	400	400/200	TSVG304A
800-1600	400	600/300 ²	TSVG306A
	800	800/400	TSVG308A
	1000	800/400 ²	TSVG808A
1600	1000	1000/500	TSVG810A
	1600	1200/600 ²	TSVG812A
	1600	1600/1000	TSVG816A
2000	2000	2000/1000	TSVG820A
	1000	800/400 ²	TSVG808A
	1000	1000/500	TSVG810A
3000	1000	1200/600 ²	TSVG812A
	1000	1600/1000 ²	TSVG816A
	2000	2000/1200	TSVG820A
	2500	2500/1800	TSVG825A
4000	3000	3000/2400	TSVG830A
	4000	4000/3000	TSVG940A

¹Match neutral current sensor rating (or tap setting) to circuit breaker sensor rating.

²For use with multiple source ground fault protection schemes. Rating does not match EntelliGuard™ TU and MicroVersaTrip™ Plus or PM frame sensor.

Neutral Current Sensors¹

Breaker Frame (Amperes)	Breaker Sensor Rating (Amperes)	Neutral Sensor Rating or Tap Settings (Amperes)	Product Number of Window Sensor	Inside Diameter (inches)
800	800	800/400	SSVG808W	4.25
1200	1200 ³	2000/1200	SSVG820W	5.63
	1600 ³	1600/1000	SSVG816W	5.63
1600	1600	1600/1000	SSVG816W	5.63
2000	2000	2000/1200 ³	SSVG820W	5.63
2500	2500	2500/1800	SSVG825W	5.63
3000	3000	4000/3000	SSVG940W	6.50
4000	4000	4000/3000	SSVG940W	6.50

¹Match neutral current sensor rating (or tap setting) to circuit breaker sensor rating.

³At time of initial product release, the 1200A new HPC Switch was using 1600A installed sensors and a 1200A rating plug. Later models may or may not use 1200A phase sensors. Match Neutral sensor tap to HPC sensor rating.

³Outline Drawing 10112973P1.

Portable Test Set

The portable, battery-powered test kit provides self-tests and functional trip/no trip tests. It also provides defeat of the ground fault function and can be used in conjunction with high current test equipment. Interface is via a plug on the front of the trip unit and test can be conducted with the breaker in service. Test kits use either 120 Vac power source or internal batteries (not included).

Description	Trip Unit Type	Product Number
Portable Test Set	MicroVersaTrip™ only	TVRMS2
	EntelliGuard™ TU, <i>microEntelliGuard™</i> only	GTUTK20

Portable Battery Pack

The hand-held Portable Battery Pack provides an independent power source for EntelliGuard™ TU, *microEntelliGuard™*, MicroVersaTrip™ Plus and MicroVersaTrip™ PM trip units as an alternative to a test set. The battery pack is used to power up the trip unit to set or adjust trip set points when the breaker is on the bench or otherwise not powered up. For *microEntelliGuard™* trip units, the battery pack connects to the trip unit through the 15-pin connector. A battery pack adapter cable is required. For MicroVersaTrip™ Plus and MicroVersaTrip™ PM trip units, the battery pack connects to the trip unit through the rating plug test jack. The battery pack requires three standard 9 Vdc alkaline batteries (not included).

Description	Product Number
Portable Battery Pack	TVPBP
EntelliGuard™ TU, <i>microEntelliGuard™</i> Battery Pack Adapter Cable	TVPBPACC



Neutral Current Sensor



SSVG Neutral Current Sensors

POWER LEADER™ Power Supplies

Power supply for furnishing 24Vdc control power for EntelliGuard™ TU, MicroVersaTrip™ Plus and PM trip units.

Description	System Requirements	Product Number
1.5 ampere power supply Price one PLPS4G01 for each line-up. 45 trip units ⁴ and 100 ft. maximum.	Input power, 100VA (85-265Vac or 100-370Vdc)	PLPS4G01

⁴20 trip units maximum for EntelliGuard™ TU

Reference

Instructions	GEH-6492
--------------	----------

POWER LEADER™ Voltage Conditioner

Conditions and scales 120 Vac to 1.76 Vac for use by the trip unit for voltage sensing. Provides transient protection. Voltage conditioners require isolation PTs.

Description	System Requirements	Product Number
Supplies isolated bus voltage signal to EntelliGuard™ TU and MicroVersaTrip™ PM trip units.	One set of 3 voltage conditioners required for each voltage sensing location. PTs also required.	PLVC1G01

Reference

Instructions	GEH-5946
--------------	----------

Rating Plug Removal Tool

Product Number
TRTOOL



Low Voltage Power & Insulated Case Circuit Breakers Section 8

Power Break™ II Circuit Breakers

Draw-out Breaker Accessories

Features

- Draw-outs through 4000 amperes are UL Listed, 100% rated
- Modular design for simplified installation—6 basic sizes—800, 1600, 2000, 2500, 3000, 4000—5 inch pole centers
- Screw racking mechanism provides positive racking motion
- Self aligning primary and secondary disconnects
- Four position draw-out—engaged, test, disengaged, fully withdrawn—simplifies system testing and inspection
- Breaker position indicator clearly shows breaker position
- Provisions for padlocking breaker in test or disengaged position
- Mechanical interlock logic prevents movement of a closed breaker
- Suitable for reverse feeding

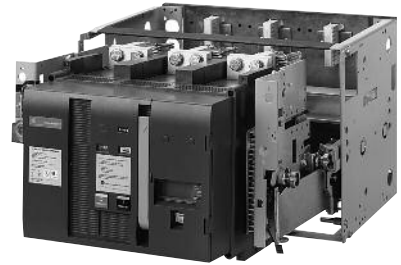

Draw-out Breaker in Substructure

Description

The draw-out assembly consists of a substructure housing unit designed as a compact self-supporting unit and a draw-out breaker which must be ordered separately. The substructure contains mounting holes, self-supporting male plugs and extendable rails, and can be ordered separately for installation in your switchboard or enclosure.

The Power Break™ II draw-out breaker is a self-contained, heavy-duty assembly designed to offer simplified breaker inspection without de-energizing the main bus structure.

The draw-out breaker comes complete with racking mechanism drive, wheels, primary and secondary disconnects and cooperating interlock systems.

Accessories such as dead-front shutters, by-pass switches (position switches), and padlock devices are available and field installable.

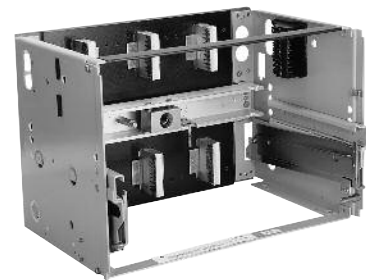

1600-ampere substructure for standard break breaker

OEM Substructures

Substructures are available for both standard and Hi-Break Power Break™ II breakers. Holes are provided for bolting on a shelf or supports. Holes are also provided in the primary stabs for bolting to busbars or terminal lugs. Substructure secondary disconnects are ordered and priced separately. Order Hi-Break substructures for use with Power Break™ II switches.

Frame Rating (Amperes)	Standard Break Product Number	Hi-Break Product Number
800	SPSDOS08	SPHDOS08
1600	SPSDOS16	SPHDOS16
2000	SPSDOS20	SPHDOS20
2500	SPSDOS25	SPHDOS25
3000	SPSDOS30	SPHDOS30
4000	SPSDOS40	SPHDOS40

Secondary Disconnect for Draw-out Breakers

Control wiring is connected through draw-out secondary disconnects in the "TEST" and "CONNECTED" positions only. Up to 72 control circuits are possible through 36 position plug-style secondary disconnect blocks factory mounted to each side of draw-out breakers. One substructure disconnect (SPDOSD36S) must be ordered for each breaker when accessories or communications are used. When auxiliary switches are used along with any other electrical accessory or communications, two disconnects must be ordered.

Location	Product Number
Substructure	SPDOSD36S
Breaker ¹	SPDOSD36B

¹Order for replacement only. Included and factory wired with draw-out breaker.



Low Voltage Power & Insulated Case Circuit Breakers Section 8

Power Break™ II Circuit Breakers

Draw-out Breakers and Accessories

All devices UL Listed for factory or field installation except where noted.

Shutter Kit

This field installable kit provides shutters used to prevent unintentional contact with potentially live primary disconnect stabs when a breaker is racked out of an energized switchboard compartment.

Frame Rating	Product Number
800-2000A	SPDSS20
3000A	SPDSS30
4000A	SPDSS40

By-Pass Switch

Provides positive indication that the draw-out breaker or switch primary contact fingers are fully connected to the main bus in the substructure. Switch contacts change states only after the primary fingers are fully connected when the breaker is being moved from the DISCONNECTED position through the TEST position and into the CONNECTED position.

May be used to provide control circuit continuity or downstream signaling that the draw-out breaker is connected in addition to the visual position indicator on the draw-out substructure. The By-pass switch accessory does not indicate either the TEST or DISCONNECTED position. The switch assembly mounts on the stationary frame and the actuator mounts to the carriage. Switch contacts are rated at 10A at 600 Vac, 0.75A at 125 Vdc, and 0.25A at 250 Vdc.

Number of Switch Elements	Product Number
2 NO/2 NC	TDOB2L
4 NO/4 NC	TDOB4L
6 NO/6 NC	TDOB6L

Racking Padlock Provision

The racking padlock provides a means for the user to prevent racking tool engagement, thereby preventing movement of the breaker between the DISCONNECTED, TEST and CONNECTED positions.

Frame Rating	Product Number
All	TDOPC

Lifting Bar

The lifting bar provides a means of safely lifting a draw-out circuit breaker. A chain hook can be attached to the central hole in the lifting bar or a 1" diameter black iron pipe can be put through the two holes above the hooks, allowing two people to carry the breaker below waist level from either side of the breaker.

Frame Rating	Product Number
All	TDOLB

Racking Tool

The racking tool is a drive wrench with a square 1/2" socket that engages the racking mechanism of the draw-out breaker.

Frame Rating	Product Number
All	TDORT

Mechanical Interlocks

Mechanical interlocks provide the same function as the walking beam accessory for stationary breakers, except they are used with two draw-out breakers: mounted on common compartment centerline, in either the same vertical section or adjacent vertical sections.

Envelope Size	Product Number
800-2000	SPDOWB20
2500-4000	SPDOWB40

Rail Kit

This field installable rail kit may be used to shorten the two standard OEM substructure rails by 3-1/2 inches.

Product Number
SPRAILS

Position Switch

Provides positive indication when the draw-out breaker or switch primary contact fingers have been fully withdrawn from the main bus connections. Switch contacts change state only after the primary fingers are fully disconnected when the breaker is being moved from the CONNECTED position through the TEST position and into the DISCONNECTED position.

May be used as part of a safety interlocking system in addition to the visual indicator on the draw-out substructure. The Position Switch accessory does not indicate either the TEST or CONNECTED position. The switch assembly mounts on the stationary frame and the actuator mounts to the carriage. Switch contacts are rated at 10A at 600 Vac, 0.75A at 125 Vdc, and 0.25A at 250 Vdc.

Number of Switch Elements	Product Number
2 NO/2 NC	SDOPS2L
4 NO/4 NC	SDOPS4L
6 NO/6 NC	SDOPS6L



Low Voltage Power & Insulated Case Circuit Breakers Section 8

Reference Publications

UL/CSA File Numbers

Power Break™ Breakers	E11592/LR10263
MicroVersaTrip™ Plus and MicroVersaTrip™ PM, EntelliGuard™ TU Trip Unit and Power+ Trip Units	E11592/LR10263
MicroVersaTrip™, EntelliGuard™ TU and Power+ Rating Plugs	E11592/LR10263
Accessories	E57253/LR10263
Molded Case Switches	E57546/LR16271

EntelliGuard™ G

EntelliGuard™ G IOM	DEH-41304
Time Current Curves: EntelliGuard™ TU Trip Unit for EntelliGuard™ G; Long-Time Circuit Breaker Characteristics	DES-090
Time Current Curves: EntelliGuard™ TU Trip Unit for EntelliGuard™ G; Long-Time Fuse-Like Characteristics	DES-091
Time Current Curves: EntelliGuard™ TU Trip Unit for EntelliGuard™ G; Short-Time Pickup and Delay Bands	DES-092
Time Current Curves: EntelliGuard™ TU Trip Unit for EntelliGuard™ G; Ground Fault	DES-093
Time Current Curves: EntelliGuard™ TU Trip Unit for EntelliGuard™ G; Instantaneous, Override (HSIOC), Reduced Energy Let-Through Instantaneous (RELT)	DES-094
UL Component Recognized Series Connected Ratings and CSA Certified Series Rated Combinations	DET-008
Undervoltage Release User Manual	DEH-41361
Time Delay Module User Manual	DEH-41362
Closing Coil User Manual	DEH-41363
Motor Operator User Manual	DEH-41366
Electrical Close Switch	DEH-41374
Spring Charge Contact	DEH-41375
Castell Lock Kit	DEH-41376
Door Interlock User Manual	DEH-41377
Cassette Ronis Lock User Manual	DEH-41380
Contact Wear Indicator User Manual	DEH-41382
Wall Mounting Kit	DEH-41383
IP54 Door	DEH-41384
Escutcheon Kit	DEH-41386
Arcing Contacts Assembly	DEH-41390
Racking Handle	DEH-41392
Cluster Contacts User Manual	DEH-41394
Cluster Pliers Assembly	DEH-41395
Secondary Disconnects - Drawout	DEH-41401
Command Close Coil	DEH-41418
Ready To Close (RTC)	DEH-41419
Coil Signaling Contacts	DEH-41420
Back Connected Terminations for Cassette	DEH-41430
	DEH-41431
	DEH-41433
	DEH-41434
	DEH-41437
Back Connected Terminations for Breaker	DEH-41439
	DEH-41440
	DEH-41441
	DEH-41442
	DEH-41443
	DEH-41444
	DEH-41445
	DEH-41608
Contact Wear Indicator	DEH-41446
Cluster pad Assembly	DEH-41447
	DEH-41448
	DEH-41449
	DEH-41450
Mechanical Interlocks (Fixed)	DEH-41451
Mechanical Interlocks (Drawout)	DEH-41455
Cassette Interlock User Manual	DEH-41459
Clusters	DEH-41460
Network Interlock Device (NI)	DEH-41461
Flat Front Termination ANSI/UL	DEH-41463
Remote Racking Operator	DEH-41467
Key Interlock Casste Mounted	DEH-41500
CVCB Coil Signal Status	DEH-41517
Neutral Sensor Kit - Rogowski	DEH-41387

24 Vdc Power Supply	GEH-6492
Arc Chute Kit	DEH-41389
Earthing Device Kit	DEH-41379
EntelliGuard TU Rating Plugs	DEH-41318
EntelliGuard TU Test Kit	DEH-4568
EntelliGuard TU Trip Unit IOM	DEH-4567

Power Break™ II Time Current Curve-Numbers

	Functions	Curve No.
Enhanced MicroVersaTrip™ Plus and MicroVersaTrip™ PM Trip Units	Long-time Delay with Instantaneous	GES-9889
	Long-time Delay, Short-time Delay with Instantaneous	
	Ground Fault	GES-9890

Power Break™ II Instructions for Breakers and Accessories

Power Break™ II Circuit Breakers-800-4000 A frames, 240-600 Vac	GEH-6270
Power Break™ II Circuit Breakers-Draw-Out 800-4000 Ampere Frames	GEH-6271
Power Break™ II Circuit Breakers-Draw-Out Substructure	GEH-6272
Power Break™ II Circuit Breakers-Trip Unit	GEH-6273
Power Break™ II Circuit Breaker Accessories-Auxiliary Switch Module	GEH-6274
Power Break™ II Circuit Breaker Accessories-Bell Alarm-Alarm Only	GEH-6275
Power Break™ II Circuit Breaker Accessories-Door Interlock	GEH-6276
Power Break™ II Circuit Breaker Accessories-Lug Kits and T Studs	GEH-4546
Power Break™ II Circuit Breaker Accessories-Bell Alarm with Lockout	GEH-6278
Power Break™ II Circuit Breaker Accessories-Key Interlock Provision	GEH-6279
Power Break™ II Circuit Breaker Accessories-Mechanical Counter	GEH-6280
Power Break™ II Circuit Breaker Accessories-Motor Operator Mechanism	GEH-6281
Power Break™ II Circuit Breaker Accessories-Push Button Cover	GEH-6282
Power Break™ II Circuit Breaker Accessories-Remote Close	GEH-6283
Power Break™ II Circuit Breaker Accessories-Shunt Trip	GEH-6284
Power Break™ II Circuit Breaker Accessories-Undervoltage Release	GEH-6285
Power Break™ II Circuit Breaker Accessories-Walking-Beam Interlock	GEH-6286
TVRMS2 Test Kit	GEK-97367
Power Break™ II Circuit Breaker Accessories-Draw-Out Substructure Secondary Disconnect	GEH-6460
Power Break™ II Circuit Breaker Accessories-Draw-Out Substructure Rail Kit	GEH-6440
Walking Beam Interlock 800A, 1600A, 2000A	GEH-6286
Walking Beam Interlock 2500-3000A	DEH-009
Walking Beam Interlock 4000A	DEH-010
Draw Out Mechanical Interlock 800-2000A	DEH-011
Draw Out Mechanical Interlock 2500-4000A	DEH-012
Neutral Kit	DEH-024
Hidden "ON" Button	DEH-025
High Voltage Shunt Trip	GEH-6519
High Voltage Under Voltage Release	GEH-6520
Under Voltage Release Time Delay Relay	GEJ-4699
EntelliGuard™ TU Digital Test Kit	DEH-4568A
EntelliGuard™ TU Conversion/Upgrade Kits	DET-722C
EntelliGuard™ TU Conversion Kits	DEH-3456
EntelliGuard™ TU Conversion Kits	DEH-3456
Drawout Position Switch	DEH-40528
Stop Block Kit	DEH-40466

Power Break™ II Circuit Breakers Trip Units

Power+ Trip Unit	DEH-049
Installation Operation and Maintenance Manual for the UL Version of the EntelliGuard™ TU Trip Unit	DEH-4567

Continued on page 8-127



Low Voltage Power & Insulated Case Circuit Breakers Reference Publications

Section 8

Power Break™ II Circuit Breakers

MicroVersaTrip™ Plus and MicroVersaTrip™ PM Rating Plugs	GEH-5933
EntelliGuard™ TU Rating Plugs	DEH-41318
Enclosures 800-2000A	GEH-6503

Power Break™ II Insulated Case Switches

800-4000A, 240-600 Vac	DEH-40380
Power+ Control Units	DEH-40381

WavePro Low Voltage Power Breakers

WavePro Small Frame Maintenance Manual, WP-08-20	DEH-136
WavePro Large Frame Maintenance Manual, WP-32-50	DEH-137
User's Guide–MicroVersaTrip™ Plus/PM Trip Units	DEH-178
User's Guide–Power+ Trip Unit	DEH-179
Power Leader™ Recommended Power Supplies	GEH-5945
Power Leader™ Voltage Conditioner	GEH-5946
Portable Battery Power Pack	DEJ-001
Zone Selective Interlock Module	GEK-64467
WavePro Small Frame User's Manual, WP-08-20	DEH-134
WavePro Large Frame User's Manual, WP-32-50	DEH-135
User's Guide TVRMS2 Programmer Portable Test Set	GEK-97367A
WavePro Small Frame (800-2000A) Renewal Parts Guide	DEF-004
WavePro Large Frame (3200-5000A) Renewal Parts Guide	DEF-005
WavePro Time-Current Curves (LSI)	DES-001
WavePro Time-Current Curves (GF)	DES-002
WavePro Time-Current Curves (Special GF)	DES-026
WavePro Breaker Application Guide	DET-167
WavePro Selection and Pricing Guide	DEP-080
WavePro User Publications Summary–	
WavePro Breakers and AKD-10 Switchgear	DEE-194

Gerapid High Speed DC Circuit Breakers

Gerapid Brochure	DET-379
Gerapid Application Guide	DET-739
Gerapid Users Guide for 2607, 4207, 6007 & 8007	S47183e
Gerapid Users Guide for UL Breakers	S47183De
Gerapid Users Guide for Rectifier Breakers 8007R & 10007	DTR01807



