

Modicon M580 automation platform

Catalog

January 2014



How can you fit a 6000-page catalog in your pocket ?

Schneider Electric provides you with the complete set of industrial automation catalogs all on a handy USB key for PC or in an application for tablets



Digi-Cat, a handy USB key for PC



- > Convenient to carry
- > Always up-to-date
- > Environmentally friendly
- > Easy-to-share format

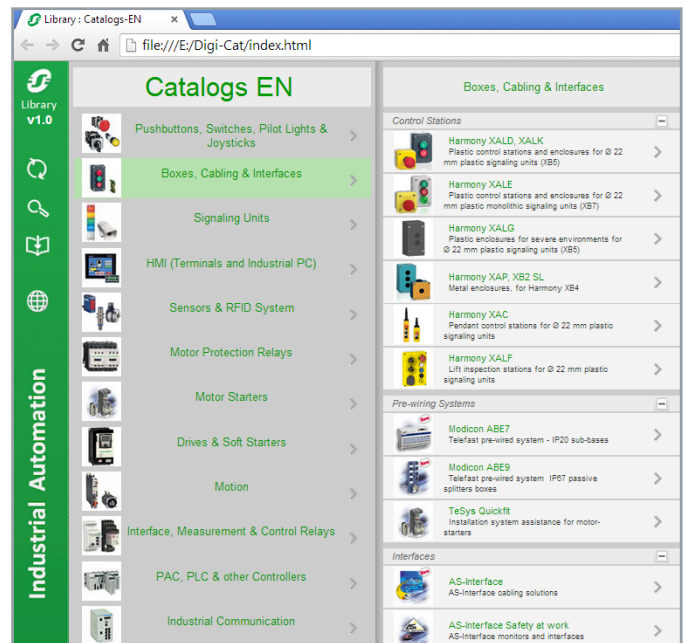

Contact your local representative to get your own Digi-Cat



e-Library, the app for tablets

If you have an iPad®:

- > Go to the App Store and search for e-Library
- > or scan the QR code



If you have an Android tablet:

- > Go to the Google Play Store™ and search for eLibrary
- > or scan the QR code

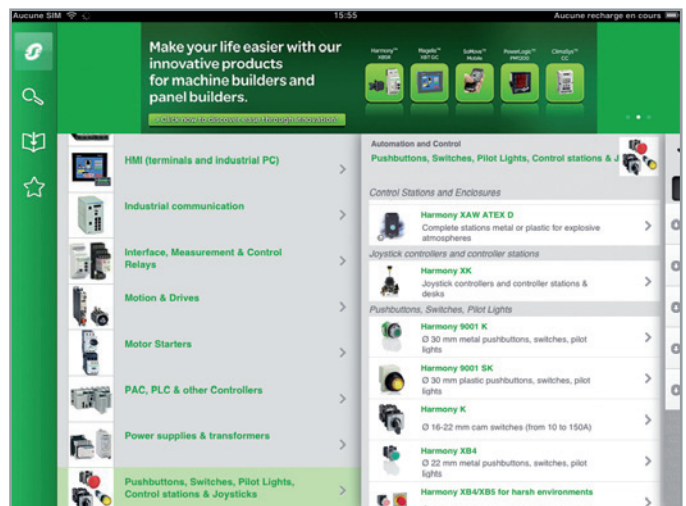

General contents

Presentation.....	1
I/O architectures.....	2
Communication	3
Software.....	4
Ruggedized Modicon M580 modules.....	5
Standards and certifications	6
Services	7
Technical information, index.....	8

1 - Presentation, processor modules, single-rack and multi-rack configurations



Presentation

- General presentation..... page 1/2
- Composition page 1/8
- Compatibility..... page 1/14

Processor modules

Selection guide page 1/18

- Presentation..... page 1/20
- Description..... page 1/21
- Memory structure page 1/22
- Memory cards..... page 1/22
- Protecting the application page 1/22
- Modifying the program in online mode page 1/22
- References page 1/23

Single-rack configuration

- Presentation, description, functions page 1/24
- References page 1/25

Multi-rack configuration

- Presentation, description page 1/26
- References page 1/28

1

Modicon M580 ePAC Control at the heart of PlantStruXure

Modicon M580 combines Unity PAC's existing features with innovative technologies to deliver Schneider Electric's complete Ethernet based PAC

The Modicon M580 ePAC (Programmable Automation Controllers) feature openness, flexibility, robustness and sustainability. The M580 are designed with an Ethernet backbone to optimize connectivity and communications. They support X80 common I/O modules which can be easily integrated into its architecture. The powerful processors offer high levels of computation for complex networked communication, display and control applications.

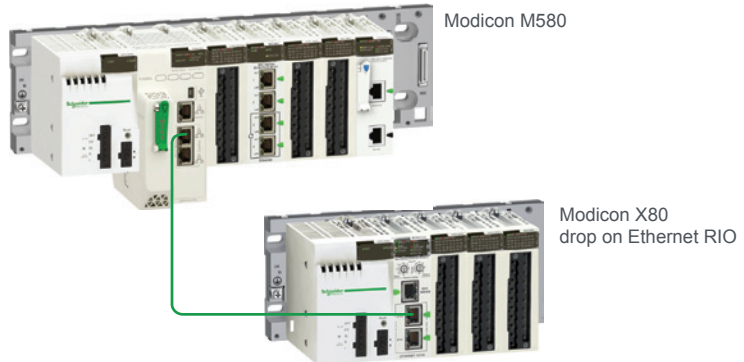

Innovative

ePAC concept

- > Top-to-bottom standard Ethernet network
- > Open architecture with direct Ethernet connection on backplane



Direct Ethernet connection backplane

- Ethernet
- X-bus

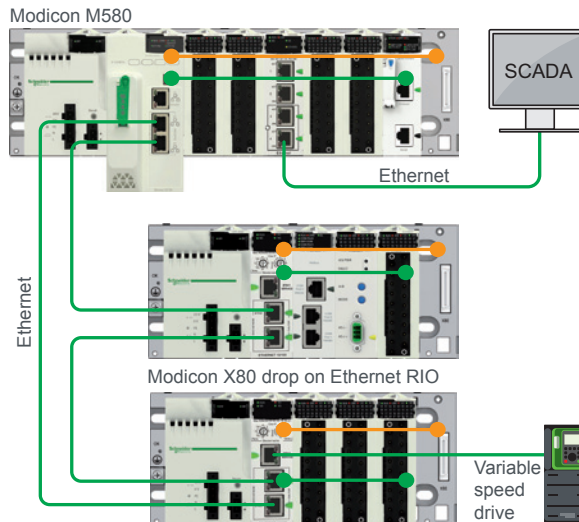

 **ODVA organization:** supports network technologies built on EtherNet/IP

 **FDT Technology:** an international standard with broad acceptance in the automation industry



Cybersecurity ready

- > Cybersecurity ready with Achilles Level 2 certification and advanced built-in cyber security features
- > Embedded security features as defined by standard IEC 62443
- > M580 hardware platform:
 - > Unused services can be disabled
 - > Remote access to PLC can be controlled
- > M580 programming software with integrity check of Unity Pro executable files

+ Open and secure solution based on standards

Innovative (continued)

Advanced technologies

- > Based on high-speed dual-core processor (ARM® type)
- > High-speed communication, application and execution
- > Innovative mechanical and electronic design for high EMC immunity and ruggedness that is superior to the required IEC standards
- > Supports extended temperature range from -25°C to +70°C

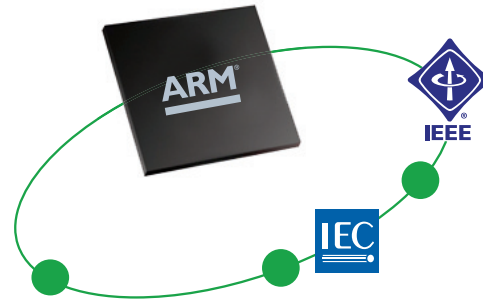

Ethernet & Web
W3C®



Modicon M580 design is compliant with automation standards



No program required with time-stamping solution mode

High precision

- > Native deterministic Ethernet network
- > Ability to deliver 1 ms I/O resolution through native time-stamping at source with specific time-stamping modules via OPC server
- > Applications include functions such as:
 - > sequence of events recording (SER)
 - > utility substation automation
 - > protective relay trip history
 - > alarm/event logs
 - > time-stamping of power monitoring data logs

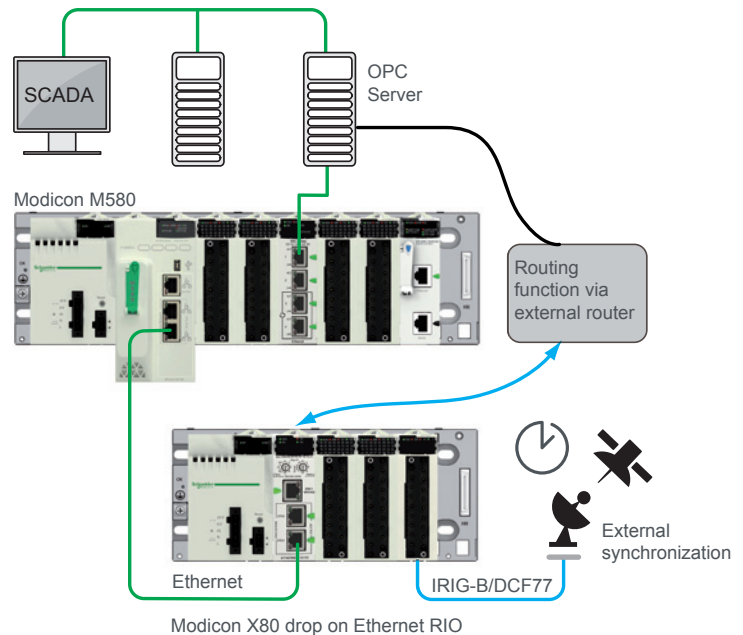

+ Modify your process and architecture during runtime

1



Extend your process or application easily with flexible Modicon M580 topology

Simple and flexible

Flexibility in design

- > Flexible topology allows simple integration of devices
- > Ability to mix remote equipment, distributed equipment and other devices on the same Ethernet field network with complete software integration
- > Transparent access to data through Ethernet backbone
- > Simple HMI integration via third port on remote I/O head
- > Interface to other popular fieldbus and device networks including AS-Interface, Modbus, Profibus, and HART

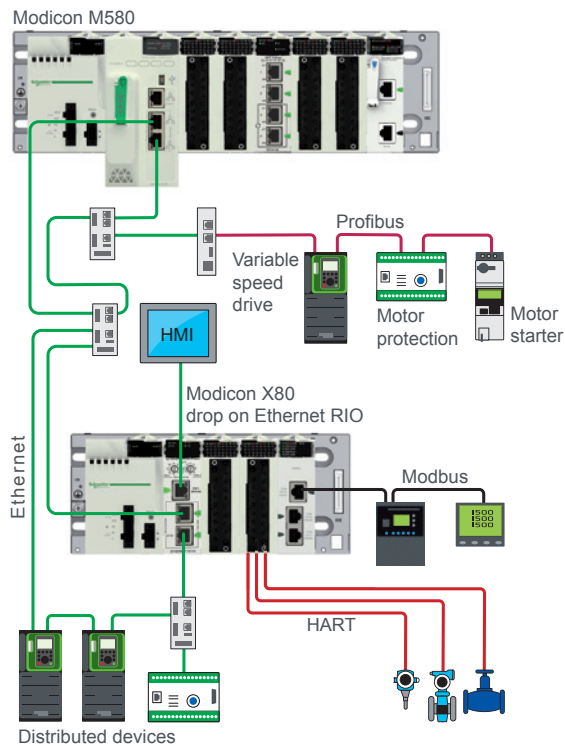

Optimized architecture

- > Simple daisy chain loop

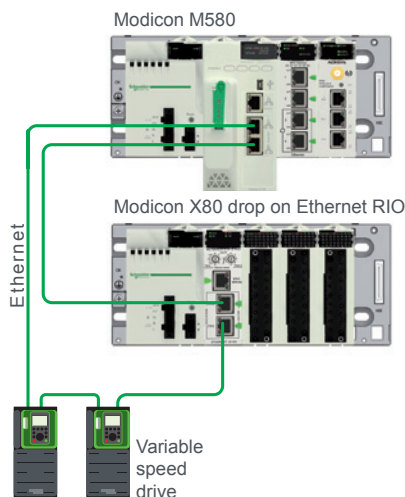

No switches required for simple main loop

+ Design your architecture without constraints



Data at your fingertips wherever you are

Simple and flexible (continued)

Easy diagnostics

- > Ethernet delivers information everywhere
- > Simple remote and mobile diagnostics (smartphone, tablet, etc.)
- > Embedded web server for web access
- > Manage SCADA screens on HMI and access HMI screens
- > Built-in Vijeo Citect objects for advanced integrated diagnostics

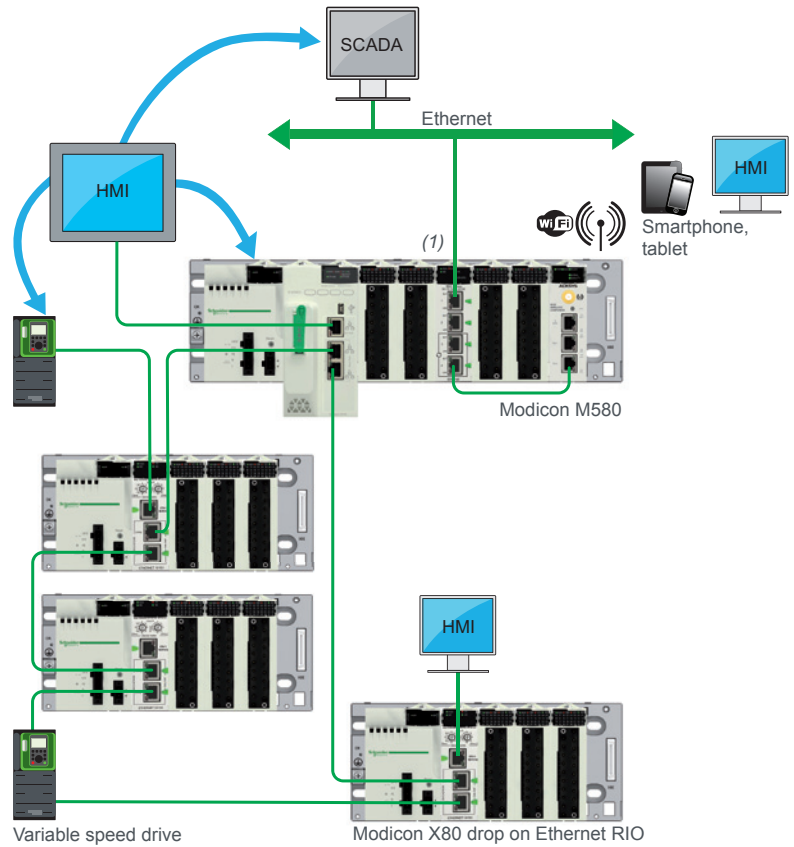

(1) This schematic diagram will operate with the new BMENOC03•1 modules (available second quarter 2014 to replace the existing BMXNOC0402) with complete Ethernet transparency via connection to the Ethernet backplane.

1

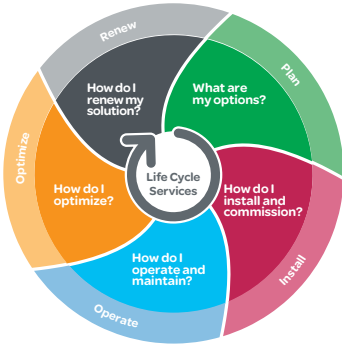

Modicon family with common X80 modules

Simple and flexible (continued)

Change configuration on the fly without stopping the process

- Add or remove discrete and analog I/O modules on RIO drop (not time-stamped)
- Add a new RIO drop
- Modify channel configuration parameters
- Automatic reconfiguration of modules on hotswap
- Online application changes during process runtime including adding new variables shared with HMI (Human/Machine Interfaces)



Sustainable

Protect investments

- Standardize on the Modicon family with common X80 modules and reduce training and maintenance costs



Modicon Quantum Ethernet I/O



Modicon M340



Modicon X80 I/O

Modicon M580



- Keep your existing Modicon Premium I/O and wiring
- Smooth migration paths for both hardware (quick wiring adapter) and software (SW converters)



Installed base migration: keep your existing I/O and wiring

Modicon M580 Modicon X80 expansion rack

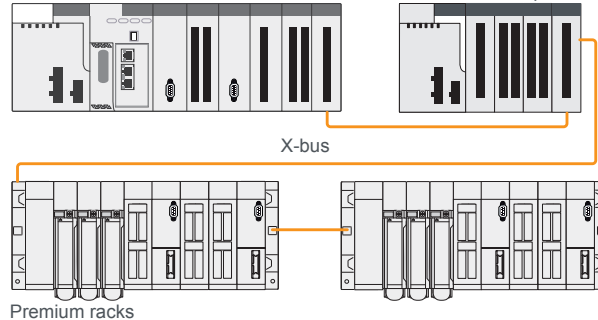

+ Protect existing and future investments



Winning associations in PlantStruXure architecture

Modicon M580 Ethernet PACs have strong associations with:

Partners

- > Able to develop X80 modules on Ethernet backplane with Ethernet tool kit backplane
- > For specific applications or communication modules: weighing, Wi-Fi, etc.

Vijeo Citect SCADA

- > To manage time-stamped events through OPC server in a system approach
- > To display Unity Pro diagnostic buffers
- > To integrate objects quickly and easily to provide advanced diagnostic information

Altivar variable speed drives

- > Simple integration of Altivar variable speed drive range on Ethernet network through FDT/DTM
- > Dual-port connection is possible for high availability

HMI Magelis™ range

- > Connection through X80 Wi-Fi, Web server access, multiple screens on Ethernet backbone, diagnostic buffers supported by Vijeo Designer, export of Unity Pro data to Vijeo Designer

Services on installed base

- > Schneider Electric provides smooth migration paths to migrate existing wired legacy I/O to M580. Contact our Customer Care Center for more details.

1



Modicon M580 automation platform



BMEP582020 processor



Modicon X80 I/O platform

Presentation

The Modicon M580 automation platform is composed of the following devices:

- A **BMEP58●●●●** processor
- A Modicon X80 I/O platform
- Dedicated modules (HART, weighing, etc.)
- Ethernet backplane
- Unity

The Modicon M580 automation platform meets the needs of specialist applications such as:

- Manufacturing and large infrastructures
- Water and Waste Water (WWW)
- Food & Beverage (F&B)
- Mining, Minerals, Metals (MMM)
- Oil & Gas (O&G)

Processor modules

The **BMEP58●●●●** processor range constitutes the core of a complete control solution based on Modicon M580 specific and compatible modules and racks.

The standalone **BMEP58●●●●** processor is a modular automation processor that physically occupies two module slots on a backplane.

BMEP58●●●● processors can be installed on **BMEXBP●●●●** Ethernet + X-bus racks and **BMXXBP●●●●** (PV02 or later) X-bus racks.

The processors can manage the Modicon X80 I/O platform in a single-rack or multi-rack Ethernet PAC station. Their slots can be equipped with:

- Discrete I/O modules
- Analog I/O modules
- Counter modules
- Communication modules:
 - Ethernet Modbus/TCP network, EtherNet/IP network
 - AS-Interface actuator/sensor buses and RTU (Remote Terminal Unit) serial link
 - Modbus serial link
- Expert modules

The seven processors in this range have different memory capacities, processing speeds, number of I/O, number of supported local racks, and embedded Ethernet port functions (see page 1/23).

Modicon X80 I/O platform

The Modicon X80 I/O platform serves as the common base for automation platforms by simply adding a dedicated processor such as the M580 or M340.

It may also:

- Form part of a Quantum Ethernet I/O architecture as an Ethernet RIO (EIO) drop with a CRA bus terminal module
- Form an Ethernet Modbus/TCP DIO drop with a PRA module

The Modicon X80 I/O platform is available in single-rack or multi-rack configuration. This platform may also accept automation platform-dedicated modules (communication, application, etc.).

One Modicon X80 drop may support two racks separated by a distance of up to 30 meters/98.425 feet.

This platform, common to several automation platforms, can reduce maintenance and training costs as it comprises:

- A single range of spare parts in stock
- Training common to several PLCs

Based on the latest I/O technology, the Modicon X80 I/O platform offers:

- High-quality ruggedness and compactness
- Compliance with international certifications (ATEX, IEC, etc.)
- A wide selection of modules: Discrete or analog I/O, expert modules, communication modules, etc

Note: For further information, please consult the “Modicon X80 I/O platform” catalog available on our website www.schneider-electric.com.



HART integrated analog input module

Dedicated modules

HART integrated analog I/O modules

The Highway Addressable Remote Transducer (HART) protocol is the global standard for sending and receiving digital information across analog wires between smart devices and a control or monitoring system. The standard is controlled by the HART Communications Foundation.

HART integrated analog I/O modules can be added on the backplane of the Modicon M580 processor.

These HART modules offer 8 channels per input module and 4 channels per output module. HART integrated analog I/O modules allow the integration of HART-enabled instruments to the network architecture.

Each M580 main rack can support up to 6 HART I/O modules and each X80 RIO drop can support up to 7 HART I/O modules. These devices are configured via the Unity Pro DTM.

HART analog I/O modules are only supported by Ethernet + X-bus backplanes (main rack or RIO drop).

Note: For further information, please consult the "Modicon X80 I/O platform" catalog available on our website www.schneider-electric.com.



Scaime partner weighing module

Scaime partner weighing module

The Scaime integrated partner weighing module is a solution for integrated and distributed weighing systems.

The weighing module is only supported by Ethernet + X-bus backplanes (main rack or RIO drop).

This Scaime Ethernet system weighing transmitter offers 1 weighing channel and can take up to 100 measurements per second in order to provide a better weighing resolution.

Weighing data is easily provided to the PLC via the Ethernet backbone.

The offline configuration can be done via Unity and the online calibrations and settings can be done via FDT/DTM.

Note: For further information, please consult the "Modicon X80 I/O platform" catalog available on our website www.schneider-electric.com.

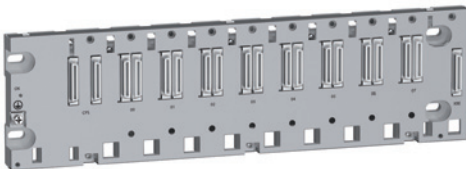

8-slot Ethernet + X-bus rack

Two rack types

M580 processors can work in either an X-bus rack or a dual (Ethernet + X-bus) rack.

Ethernet backplanes are available with 4, 8, and 12 slots.

The M580 Ethernet backplanes provide the X-bus connection and Ethernet connectivity.

A single configuration can support up to 7 standard BMX racks used as expansion racks in addition to the local rack, separated by a cumulative distance of up to 30 meters/98.425 feet.

An Ethernet RIO (EIO) drop is composed of one or two racks that can be either a BMX X-bus rack or a BME Ethernet rack. The expansion rack can only be a BMX X-bus rack. All the Ethernet racks are available in a version suitable for use in harsh environments.

An Ethernet switch is embedded in the Ethernet backplane. This switch is connected to several slots on the backplane. In the case of 12-slot backplanes, not all slots have Ethernet connectivity. Only 8 slots are available for Ethernet, but they are placed in several locations along the rack for maximum flexibility of use (see page 1/25).

M580 application design and installation

The Modicon M580 automation platform is programmed and configured using Unity Pro software version ≥ 8.0 . Bit forcing simplifies simulation and structured data simplifies diagnostics (see page 4/18).

- Use of these M580 processors requires Unity Pro Large or Extra Large programming software. This software is also compatible with the Modicon X80 I/O, Quantum, Premium, and M340 platforms
- Optionally, as required:
 - Unity EFB toolkit software for developing EF and EFB function block libraries in C language
 - Unity Dif software for comparing Unity Pro applications
 - Unity Loader software for updating Unity Pro projects and firmware



Unity Pro



Achilles Level 2 certification



BMEP582040 processor

Cybersecurity ready

The Modicon M580 is Schneider Electric's most cyber-secure platform thanks to the Achilles Level 2 certification and its advanced built-in cybersecurity features. The Achilles L2 cybersecurity certification demonstrates the robustness of the Modicon M580 platform under both extreme and common Ethernet conditions. The Modicon M580 automation platform also offers the following features:

- Protection against unauthorized remote connections via an online editable Access Control List
- Protection against remote programming changes via a password
- Option to enable or disable HTTP or FTP services
- Option to enable or disable remote run/stop commands
- Option to enable or disable remote write commands
- Authentication and integrity of the firmware
- Integrity of Unity Pro executable files
- Unnecessary services disabled by default
- Security features enabled by default

Note: For further information, please consult our website www.schneider-electric.com.

Processor performance

The M580 processor supports 4 to 8 local racks (depending on the CPU performance level), using existing X80 I/O modules and accessories. The M580 processor must be installed in the main rack, which can be a dual (Ethernet + X-bus) bus rack. M580 PLCs can support up to 8 expansion racks of 4, 6, 8, or 12 slots. These standalone processors physically occupy two module slots on a backplane.

The processors can manage Modicon X80 I/O platform in a single-rack or multi-rack Ethernet PAC station. Their slots can be equipped with:

- Discrete I/O modules
- Analog I/O modules
- Counter modules
- Communication modules: Ethernet Modbus/TCP network, EtherNet/IP network, Modbus SL
- AS-Interface actuator/sensor buses and RTU (Remote Terminal Unit) serial link
- Expert modules

The seven processors available have different memory capacities, processing speeds, number of I/O, number of supported local racks, and embedded Ethernet port functions (see page 1/23).

The M580 processor range offers the choice between 4 memory levels:

- 4 MB for **BMEP581020** processors
- 8 MB for **BMEP5820●●** processors
- 12 MB for **BMEP5830●●** processors
- 16 MB for **BMEP5840●●** processors

It also offers the choice between 2 types of Ethernet device network port:

- For **BMEP58●●20** processors: distributed I/O ports (DIO) to connect distributed equipment
- For **BMEP58●●40** processors: distributed I/O ports (DIO) to connect distributed equipment or remote I/O ports (RIO) to connect remote equipment

This range also offers different performance levels: **BMEP5840●●** processors are twice as fast as **BMEP5830●●** processors, which are themselves twice as fast as **BMEP5810●●** and **BMEP5820●●** processors.

An optional 4 GB SD memory card is supplied with M580 processors for application and data storage.

In addition, depending on the model, the processors offer:

- 1,024 to 4,096 discrete I/O
- 256 to 1,024 analog I/O
- 64 application-specific channels such as process counters, motion control, serial link, RTU, etc

Applications can be downloaded to the M580 processor when:

- Unity is connected via a local communication module such as the **BMXNOC0402** Ethernet module (1)
- Unity is connected directly to the processor through USB or Ethernet, or to the Ethernet ports of **BMECRA31210** Ethernet drop adapters and ConneXium DRS (Dual Ring Switch) switches

(1) The **BMXNOC0402** communication module will be replaced by the **BMENOC03●1** modules during the 2nd quarter of 2014.

Various architectures

The Modicon M580 ePAC offers different embedded networks to meet various architecture needs:

- Standard Ethernet DIO ports on **BMEP58●●20** processors for architectures **A, B** and **C**
- Dual Ethernet RIO ports on **BMEP58●●40** processors for architecture **D**

Architecture A: Composed of hard-wired I/O; mainly compact topology

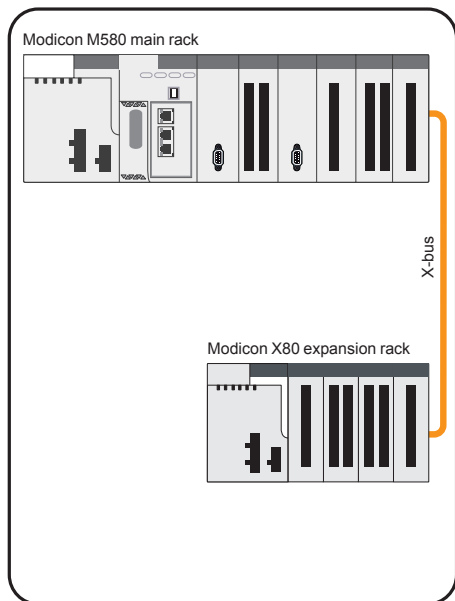

Architecture B: Composed of devices distributed over fieldbuses; mainly compact topology

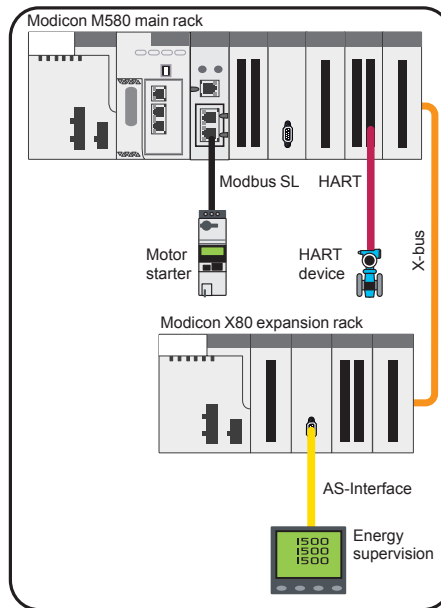

Architecture C: Composed of devices distributed over Ethernet; ideal for mainly distributed topologies

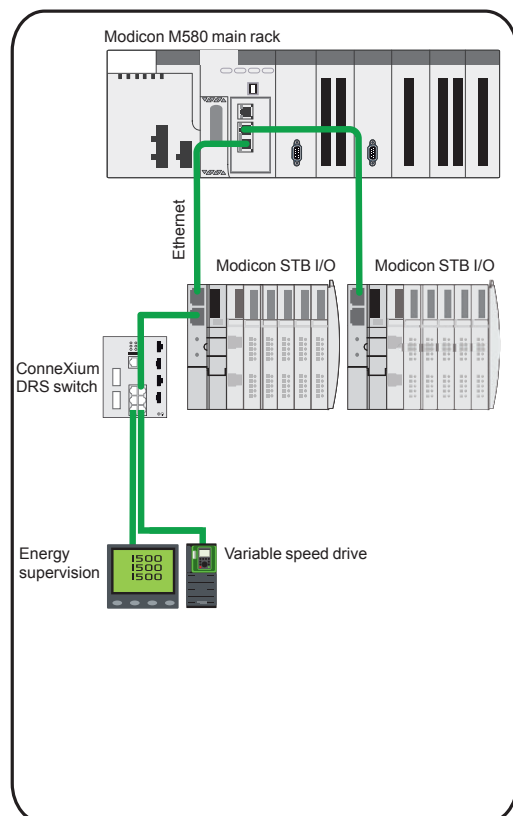

Architecture D: Uses Ethernet racks. Composed of remote devices and features remote functions, such as fieldbus master

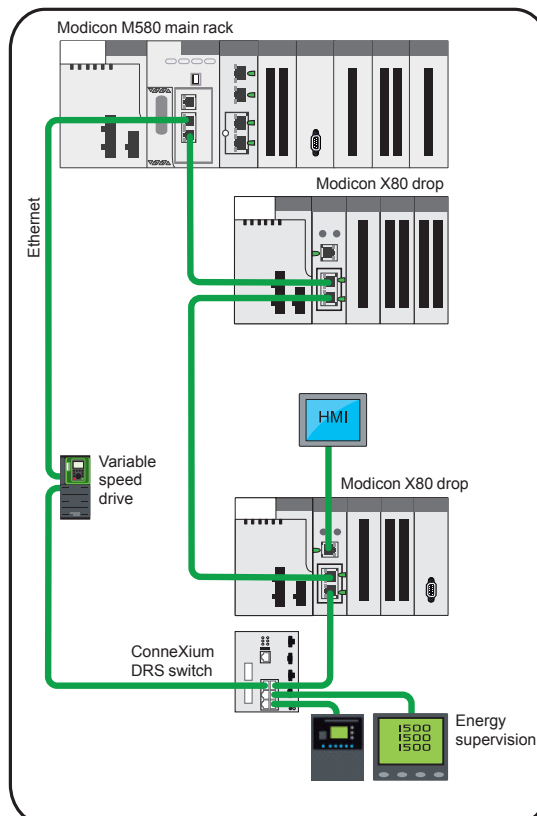

Ethernet backplane

The M580 dual backplanes provide X-bus connection and Ethernet connectivity. One Ethernet switch is embedded in the backplane with connectivity to some slots on the backplane. Not all slots have Ethernet connectivity in the case of 12-slot backplanes.

Using such connectivity, Ethernet-based modules (both Schneider Electric and third-party) can communicate with any other module or device that is reachable via the Ethernet and IP networks.

An additional connector is added to some slots of the backplane, next to the X-bus connector.

The Ethernet backplane provides multiple communication buses compared with the X-bus backplane to improve connectivity on the backplane. These buses can be connected to Ethernet modules and used to communicate different types of data for different purposes (see page 1/25).

The following communication buses are present in Ethernet backplanes:

- X-bus
- Ethernet

Expanded backplanes

To expand the configuration using additional racks, users must use a bus expansion module (**BMXXBE1000**) and X-bus cables (see page 1/26). An expanded backplane can only be an X-bus rack.

Each backplane has to include a power supply module and will support up to 12 modules.

It is also possible to expand a drop's backplane.

Each rack will be assigned a physical address using 4 micro switches located in the bus expansion module:

- The main rack containing the processor will be assigned address 0.
- The other racks will be assigned addresses 1 to 7.

Premium X-bus expansion - making migration as simple as possible

An M580 system allows TSXRKY●EX Premium expanded local racks to be added to the configuration. The use of Premium racks in a M580 configuration means the existing cabling can be retained.

This smooth migration path means that Premium devices, such as discrete and analog I/O, and counter modules, can be retained.

Indeed, the M580 processor is able to manage the I/O and application-specific modules on Premium local racks. For further information, see page 1/26.

It is also possible to replace a Premium local rack with an M580 rack if necessary.

Unity V8.0 offers the option to retain the I/O topology in the Premium expansion rack when revamping a Premium application.

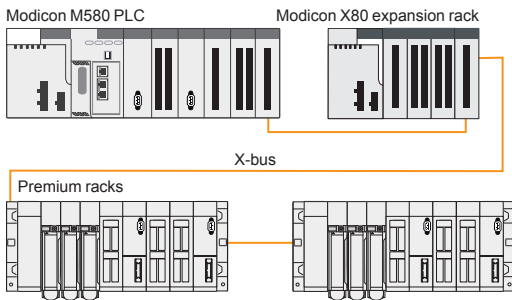

Premium X-bus expansion example



Unity Pro

Design and setup of Modicon M580 applications

Unity Pro programming software \geq V8.0 is required to set up the Modicon M580 automation platform (see page 4/18). The Unity Pro function block software libraries make it possible to meet the needs of specialist applications in various fields of application, such as:

- Water and Waste Water (WWW)
- Food & Beverage (F&B)
- Mining, Minerals, Metals (MMM)
- Oil & Gas (O&G)

To set up Modicon M580 automation platform processors, you need Unity Pro Large or Extra Large programming software identical to the one used to set up Modicon M340, Modicon Premium, and Modicon Quantum automation platforms.

Unity Pro V8.0 is compatible with Windows[®] XP, Windows 7, Windows 8, and Windows Server 2008.

Depending on requirements, you may also need:

- Unity EFB toolkit software for developing EF and EFB libraries in C language
- Unity SFC View software for viewing and diagnostics of applications written in Sequential Function Chart (SFC) or Grafset language
- Graphical Unity Diff matching software for comparing two applications configured with Unity Pro

The function block software libraries provide Modicon M580 processors with the processing capability required to meet the needs of specialist applications in the following area:

- Process control via programmable control loops (EF and EFB libraries)

This software also offers the following features:

- References
- Implicit type conversion, IEC 1131-3 proposition
- Security Editor on server
- Improved log file
- A trending tool that is synchronized on each PLC scan
- DFB providing information on users logged on to the PLC
- Data file (dtx) backup with application backup (sta/stu or zef)
- Password protection for the application running on the PLC
- Macro function

Treatment for harsh environments

If the Modicon M580 automation platform needs to be used in a very harsh environment, the ruggedized offer provides processors, power supply modules, and I/O modules on X-bus and racks with a protective coating applied to their electronic cards (see page 5/2).

This treatment improves the cards' insulation qualities and their resistance to:

- Condensation
- Dusty atmospheres (conducting foreign particles)
- Chemical corrosion, in particular when used in sulphurous atmospheres (oil refinery, purification plant, etc.) or atmospheres containing halogens (chlorine, etc.)

This protection, combined with appropriate installation and maintenance, enables Modicon M580 products to be used in harsh chemical environments such as types 3C2 and 3C3 as described in standard IEC/EN 60721-3-3.

The functional and electrical characteristics of the coated modules are identical to those of the non-coated versions.

With coated modules, the Modicon M580 automation platform may be used in harsh environments or within a range of operating temperatures from $-25\text{ }^{\circ}\text{C}$ to $+70\text{ }^{\circ}\text{C}$ / $-13\text{ }^{\circ}\text{F}$ to $+158\text{ }^{\circ}\text{F}$.

Some Modicon M580 modules are also ATEX-certified.

Modicon M580 automation platform

Modicon M580 processors

Modicon M580 platform for Unity Pro software offer

BMEP5810 model

BMEP5820 models



Racks	Maximum number of local racks Remote I/O drop of 2 racks	4 -	- 8	
I/O	Maximum number of discrete I/O channels (1)	1,024	2,048	
	Maximum number of analog I/O channels (1)	256	512	
	Maximum number of Ethernet DIO devices	64	128 64	
In-rack application-specific channels	Maximum number of application-specific channels	24	32	
	Counter (1)	BMXEHC0200 2-channel (60 kHz) or BMXEHC0800 8-channel (10 kHz) modules		
	Motion control (1)	BMXMSP0200 2-channel PTO (Pulse Train Output) module for servo drives		
	Serial link (process or RTU) (1)	BMXNOM0200 2-channel module or BMXNOR0200H module with 1 RTU serial channel		
	HART(1)	BMEAHI0812 8-channel HART analog input (4–20 mA) module or BMEAHO0412 4-channel HART analog output (4–20 mA) module		
	SSI encoder (1)	BMXEAE0300 3-channel module (SSI)		
	Time stamping (1)	BMXERT1604T 16-channel discrete input (with 1 ms resolution) module		
	Process control, programmable loops	Process control EFB library		
	Integrated communication ports	Ethernet Service port (RJ45)	1 port for DIO devices, Unity, CNM, HMI, SCADA, diagnosis & external tools	
		Ethernet Device Network dual ports (RJ45)	2 ports support DIO mode to connect devices using DIO scanner	2 ports support both RIO and DIO mode to connect Modicon X80 drops using deterministic RIO scanner and devices using DIO scanner
USB port		1 programming port (PC terminal)		
Communication modules (1)	Ethernet network	Maximum number Type of module	2 BMXNOC0402 (2) network modules with 1 EtherNet/IP channel or Modbus TCP communication protocol	
	AS-Interface	Maximum number Type of module	8 BMXEIA0100 master module	
Internal memory capacity	Program (MB)	4	8	
	Data (KB)	384	768	
	Data storage (GB)	4		
Application structure	Master task	2 processing modes (cyclic, periodic)		
	Fast task	1 processing mode (periodic)		
	Auxiliary tasks (AUX 0, AUX 1)	1 processing mode (periodic)		
	Event tasks	I/O event	64	
		Timer event	16	
Total I/O and Timer event	64			
No. of K instructions executed per ms	100% Boolean (Kinstr/ms)	10		
	65% Boolean + 35% fixed arithmetic (Kinstr/ms)	7.5		
Rack power supply		24 V $\overline{\text{---}}$ isolated, 24...48 V $\overline{\text{---}}$ isolated, or 100...240 V \sim power supply module		
Modicon M580 processor	BMEP581020	BMEP582020	BMEP582040	

(1) The maximum values for the number of I/O, application-specific channels, and the number of networks are not cumulative (they are limited by the maximum number of slots in the configuration, 1 rack: 11, 2 racks: 23, 3 racks: 35 and 4 racks: 47.)
 (2) The BMXNOC0402 communication module will be replaced by the BMENOC03•1 modules during the 2nd quarter of 2014.

BMEP5830 models

BMEP5840 models



8			
-	16	-	16
3,072		4,096	
768		1,024	
128	64	128	64
64			
BMXEHC0200 2-channel (60 kHz) or BMXEHC0800 8-channel (10 kHz) modules			
BMXMSP0200 2-channel PTO (Pulse Train Output) modules for servo drives			
BMXNOM0200 2-channel module or BMXNOR0200H module with 1 RTU serial channel			
BMEAHI0812 8-channel HART analog input (4–20 mA) or BMEAHO0412 4-channel HART analog output (4–20 mA) module			
BMXEAE0300 3-channel module (SSI)			
BMXERT1604T 16-channel discrete output (with 1 ms resolution) module			
Process control EFB library			
1 port for DIO devices, Unity, CNM, HMI, SCADA, diagnosis & external tools			
2 ports support DIO mode to connect devices using DIO scanner		2 ports support both RIO and DIO mode to connect Modicon X80 drops using deterministic RIO scanner and devices using DIO scanner	
2 ports support DIO mode to connect devices using DIO scanner		2 ports support both RIO and DIO mode to connect Modicon X80 drops using deterministic RIO scanner and devices using DIO scanner	
2 ports support DIO mode to connect devices using DIO scanner		2 ports support both RIO and DIO mode to connect Modicon X80 drops using deterministic RIO scanner and devices using DIO scanner	
1 programming port (PC terminal)			
3		4	
BMXNOC0402 (2) network modules with 1 EtherNet/IP channel or Modbus TCP communication protocol			
8			
BMXEIA0100 master module			
12		16	
1,024		2,048	
4			
2 processing modes (cyclic, periodic)			
1 processing mode (periodic)			
1 processing mode (periodic)			
128			
32			
128			
20	40		
15	30		
24 V $\overline{\text{---}}$ isolated, 24...48 V $\overline{\text{---}}$ isolated, or 100...240 V \sim power supply module			
BMEP583020	BMEP583040	BMEP584020	BMEP584040

(1) The maximum values for the number of I/O, application-specific channels, and the number of networks are not cumulative (they are limited by the maximum number of slots in the configuration, 1 rack: 11, 2 racks: 23, 3 racks: 35 and 4 racks: 47.)
 (2) The BMXNOC0402 communication module will be replaced by the BMENOC03•1 modules during the 2nd quarter of 2014.

Modicon M580 automation platform

Processor modules

1



Modicon M580 configuration

Presentation

The Modicon M580 **BMEP58** modular processors form the core of a complete control solution based on Modicon M580 specific and compatible modules and racks. These standalone processors physically occupy two module slots (0 and 1) on a backplane.

The processors can manage the Modicon X80 I/O platform in a single-rack or multi-rack Ethernet PAC station. Their slots can be equipped with:

- Discrete I/O modules
- Analog I/O modules
- Counter modules
- Communication modules: Ethernet Modbus/TCP network, EtherNet/IP network, Modbus serial link, AS-Interface actuator/sensor buses and RTU (Remote Terminal Unit) serial link
- Expert modules

The seven processors available in this range have different memory capacities, processing speeds, number of I/O, number of supported local racks, and embedded Ethernet port functions.

An optional 4 GB SD memory card is supplied with M580 processors for application and data storage. Each processor has a USB terminal port for connecting to a programming terminal. A temporary connection to an HMI is possible via the USB port (1).

In addition, depending on the model, these processors offer a maximum (non-cumulative) of:

- 1,024 to 4,096 discrete I/O
- 256 to 1,024 analog I/O
- 64 application-specific channels (2) (process counter, motion control, and serial link, or RTU)
- 1 Ethernet service port
- 2 Ethernet device network ports
- DIO ports (distributed equipment) for all processors
- RIO ports (remote equipment) for **BMEP58●●40** processors
- 4 "Full extended master" AS-Interface V3 actuator/sensor buses, profile M4.0

Applications can be downloaded to the M580 processor when:

- Unity is connected via a local **BMXNOC0402** communication module (Ethernet module) (3)
- Unity is connected directly to M580 through USB or Ethernet. For a faster transfer, users can select FTP protocol.

(1) Please refer to HMI catalogs on www.schneider-electric.com.

(2) Maximum number of application-specific channels per station. Only the application-specific channels actually configured in the Unity application are considered.

(3) The **BMXNOC0402** communication module will be replaced by the **BMENOC03●1** modules during the 2nd quarter of 2014.

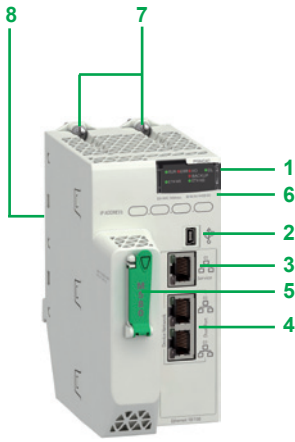

BMEP58●●●●

Description of BMEP58●●●● processors

BMEP58●●●● processors include :

- 1 A display block comprising 7 LEDs whose varying combinations provide a quick diagnostic status of the processor:
 - RUN LED (green): processor in operation (program execution)
 - ERR LED (red): processor or system detected error
 - I/O LED (red): detected I/O module fault
 - DL LED (green): firmware download is in progress
 - BACKUP LED (red): backup memory (internal or card)
 - ETH MS LED (bi-color green/red): indicates the Ethernet port configuration status
 - ETH NS LED (bi-color green/red): indicates the Ethernet connection status
- 2 A mini-B USB port for connecting to a programming terminal
- 3 An RJ45 Ethernet port that allows diagnosis of Ethernet ports and provides access to external tools, devices, and distributed I/O devices
- 5 A slot equipped with an optional SD memory card for application and data storage (an LED, located behind the door, indicates access to the memory card)
- 6 A MAC address printed on the front panel of the processor (the last two bytes of the MAC address are used to calculate the default processor IP address)
- 7 Two hooks and two screws for mechanical attachment and earthing connection to backplane
- 8 Two connectors for electrical connection to a M580 backplane (X-bus only or Ethernet backplane)

Description of BMEP58●●20 processors

- 4 BMEP58●●20 processors have dual RJ45 Ethernet ports for connection to the distributed equipment (DIO).

Description of BMEP58●●40 processors

- 4 BMEP58●●40 processors have dual RJ45 Ethernet ports for connection to the remote I/O drops (EIO) and distributed equipment (through DRS) (1).

USB terminal port

The USB port 2, offering a useful data rate of 480 Mbps, is compatible with Unity Pro programming software, OPC Factory Server (OFS), and Magelis HMI terminals (2).

BMEP58 processors can be connected to a USB bus comprising several peripheral devices. However:

- Only one processor can be connected to the USB bus
- No device on the USB bus can be controlled by the PLC (modem, printer)

Ethernet backplanes

The new range of Ethernet backplanes feature embedded Ethernet and X-bus connectivity. With 4, 8, and 12 slots, these two connectors allow the existing M580/X80 modules to be incorporated into an M580 architecture (see page 3/10).

(1) DRS: Dual Ring Switches. Supported ConneXium switches TCSESM083F23F1/063F2CU1/063F2CS1.

(2) Please refer to HMI catalogs on www.schneider-electric.com.

1

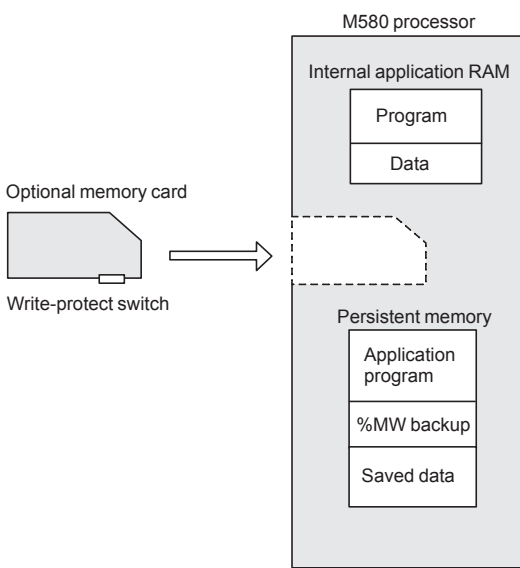

Modicon M580 application storage

Memory structure

Internal memory capacity

The internal application RAM of Modicon M580 processors stores and executes the application program. This RAM has no battery backup, which means data could be lost in the event of a power brake. To avoid data loss, the application can be backed up in the persistent memory. The internal memory provides a maximum capacity of 16 MB for memory program, 2,048 KB for data, and 4 GB for data storage.

The internal persistent memory is used by the firmware to register:

- the value of application variables
- the system state
- application backup
- a copy of %MW values

An optional memory card, **BMXRMS004GPF**, is used for application backup and data storage. It is formatted by Schneider Electric.

BMXRMS004GPF SD memory card

Modicon M580 processors support an optional 4 GB memory card **BMXRMS004GPF**. The SD memory card is of “industrial grade” and formatted for use with Modicon M580 only. The Modicon M580 does not support memory cards from Modicon M340. This card withstands operating temperatures of - 40 to 85 °C/ - 40 to 185 °F and has 10 years of file retention capacity.

Unity Pro programming software helps the application designer manage the structure and memory space of the Modicon M580 automation platform.

Protecting the application

If necessary, it is possible to limit access to the application (in terms of reading and modifying the program) by only loading the executable code in the PLC.

Additionally, a memory protection bit, set in configuration mode, is also available to help prevent any program modification (via the programming terminal or downloading).

The user has function blocks for protecting know-how by means of a signature that can be loaded and stored in the M580 processor module’s Flash memory card (code not executed if the signature is not present).

Modifying the program in online mode

As with the Modicon Premium and Quantum platforms (with Unity Pro software), the online program modification function is available on the Modicon M580 automation platform. It has the option of adding or modifying the program code and data in different places in the application in a single modification session (thus helping to ensure that modification is homogenous and consistent with the controlled process). A dedicated memory area of the application internal RAM authorizes these program modification or addition sessions while complying with the recommendation to structure the application program in several, reasonably-sized sections.

The CCOTF (Change Configuration On The Fly) function is used to add or remove discrete or analog I/O modules to/from a Modicon M580 CPU in a remote I/O drop in RUN mode. It enables Ethernet RIO drops to be added in RUN mode. The addition of a complete M580 Ethernet RIO drop in RUN mode requires Unity Pro V8.0 or higher on **BMEP581020**, **BMEP582020**, **BMEP582040**, **BMEP583020**, **BMEP583040**, **BMEP584020**, and **BMEP584040** processors.

The CCOTF function avoids interrupting processes and helps to reduce production costs. It also enables the configuration parameters of pre-existing and new Modicon M580 analog and discrete I/O modules to be modified online in a remote I/O drop.



BMEP58000000

Modicon M580 processors					
I/O capacity	Maximum number of networks	Device ports	Service port	Reference	Weight kg/lb
1,024 discrete I/O 256 analog I/O 24 application-specific channels 4 MB integrated (memory program)	2 Ethernet networks	2 DIO	1	BMEP581020	0.849/ 1.872
2,048 discrete I/O 512 analog I/O 32 application-specific channels 8 MB integrated (memory program)	2 Ethernet networks	2 DIO	1	BMEP582020	0.849/ 1.872
		2 RIO/DIO	1	BMEP582040	0.849/ 1.872
3,072 discrete I/O 768 analog I/O 64 application-specific channels 12 MB integrated (memory program)	3 Ethernet networks	2 DIO	1	BMEP583020	0.849/ 1.872
		2 RIO/DIO	1	BMEP583040	0.849/ 1.872
4,096 discrete I/O 1,024 analog I/O 64 application-specific channels 16 MB integrated (memory program)	4 Ethernet networks	2 DIO	1	BMEP584020	0.849/ 1.872
		2 RIO/DIO	1	BMEP584040	0.849/ 1.872

SD Memory card				
Description	Processor compatibility	Capacity	Reference	Weight kg/lb
SD memory card (optional) (1)	All processors	4 GB (for application backup and data storage)	BMXRMS004GPF	0.002/ 0.004



BMXRMS004GPF

Separate parts					
Description	Use		Length m/ft.	Reference	Weight kg/lb
	From	To			
Terminal port/USB cordsets	Mini-B USB port on Modicon M580 processor	Type A USB port on:	1.8/5.905	BMXXCAUSBH018	0.065/ 0.143
		- PC terminal - Magelis HMI graphic terminal	4.5/14.764	BMXXCAUSBH045	0.110/ 0.243



BMXXCAUSBH000

(1) Memory card, used for:
 - Backing up the program, constants, symbols and data
 - File storage

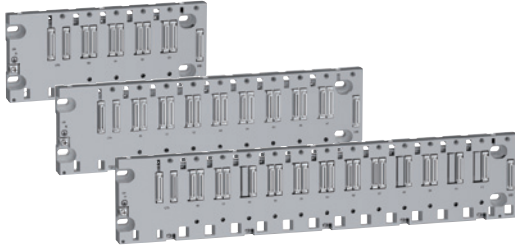

Dual Ethernet and X-bus backplanes

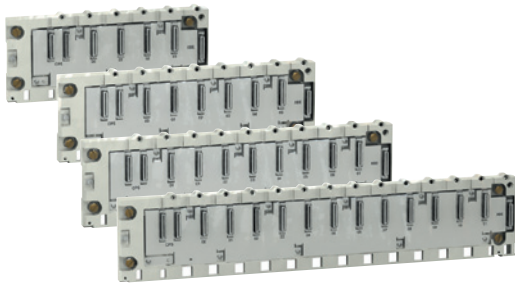

X-bus backplanes (1)(2)

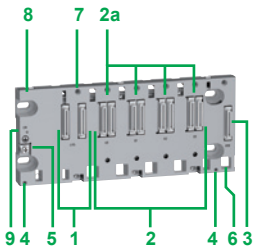

BMEXBP0400/0800 backplanes

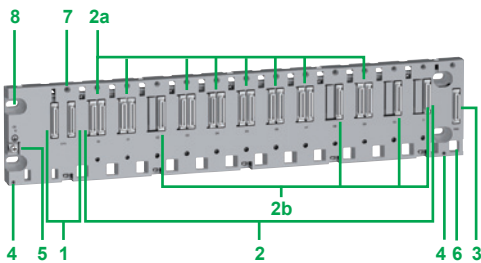

BMEXBP1200 backplane

Presentation

The M580 PAC is compatible with two types of backplane: dual Ethernet and X-bus backplanes or X-bus only backplanes (1)(2). One Ethernet switch is embedded in the backplane with connectivity to some slots on the backplane (not all slots have Ethernet connectivity).

X-bus functionality is preserved and conforms to the legacy implementation and specification. The X-bus will be used in a subset of modules on the Ethernet backplane.

The M580 backplanes provide power supply for all modules in the rack.

Function

The Ethernet backplane provides the following services to X-bus slots:

- provide rack number
- provide interconnection to all slots in main and expanded backplanes

The Ethernet interface is the main communication medium in the Ethernet backplane. All Ethernet modules on the Ethernet backplane are attached to one of several ports. The modules lead to the Ethernet switch chip embedded inside the Ethernet backplane.

The Ethernet backplane provides the following services to ETH slots:

- provide ETH connection to ETH slots
- provide point-to-point lane connection

Description

Dual Ethernet and X-bus backplanes

The quantity of X-bus and Ethernet slots found on a backplane depends on the backplane size.

BMEXBP0400/BMEXBP0800 are 4/8-slot dual Ethernet and X-bus backplanes with:

- 1 CPS slot for power supply
- 2 4 slots (**BMEXBP0400**)/8 slots (**BMEXBP0800**) with:
- 2a 4/8 Ethernet and X-bus connectors for mixed modules
- 3 Expansion: 1 connector for an X-bus backplane expansion
- 4 2 fixing points for the shielding connection bar
- 5 Protective earth screw
- 6 Slots for anchoring the module pin
- 7 Tapped holes for the locking screw on each module
- 8 4 holes for M4, M5, M6 or UNC #6-32 screws (4.32 to 6.35 mm/0.170 to 0.250 in.)
- 9 Rack is fastened to 35 mm/1.38 in. wide and 15 mm/0.59 in. deep DIN rails. Mounting on a 35 mm/1.38 in. wide and 7.5 mm/0.295 in. deep DIN rail is possible (in this case, the product withstands less mechanical stress)

BMEXBP1200 is a 12-slot dual Ethernet and X-bus backplane with:

- 1 CPS slot for power supply
- 2 12 slots with:
- 2a 8 Ethernet and X-bus connectors for mixed modules
- 2b 4 X-bus connectors for X-bus modules
- 3 Expansion: 1 connector for an X-bus backplane expansion
- 4 2 fixing points for the shielding connection bar
- 5 Protective earth screw
- 6 Slots for anchoring the module pin
- 7 Tapped holes for the locking screw on each module
- 8 4 holes for M4, M5, M6 or UNC #6-32 screws (4.32 mm to 6.35 mm/0.170 to 0.250 in.)

X-bus backplanes (1)(2)

Available with 4, 6, 8, and 12 slots with **BMXXBP0400/0600/0800/1200** for X-bus modules.

For more information, please refer to the “Modicon X80 I/O platform” catalog available on our website www.schneider-electric.com.

(1) For more information on rack, see page 1/26

(2) Mandatory PV02 version or later.

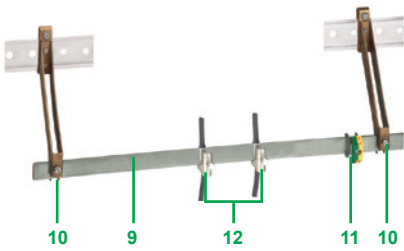

BMXXSP cable shielding connection kit

Description (continued)

Cable shielding connection kit

To be ordered separately:

A **BMXXSP** cable shielding connection kit, used to help protect against electrostatic discharge when connecting the shielding on cordsets for connecting:

- Analog, counter, and motion control modules
- Some Magelis HMI terminals (1) to the processor (via **BMXXCAUSBH** shielded USB cable)

The **BMXXSP** shielding connection kit comprises:

- 9 A metal bar that takes the clamping rings and the earthing terminal
- 10 Two sub-bases to be mounted on the rack
- 11 An earthing terminal
- 12 Not included in the shielding connection kit, the **STBXSP30** clamping rings (sold in lots of 10, cross-section 1.5...6 mm²/AWG 16...10 or 5...11 mm²/AWG 10...8)

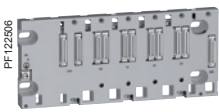

BMEXBP0400

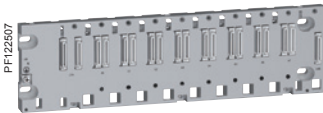

BMEXBP0800

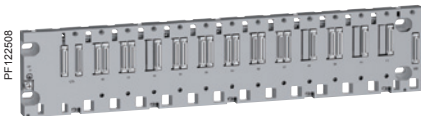

BMEXBP1200

Racks (2)(3)

Description (4)	Type of module to be inserted	Ethernet connectors	X-bus connectors	Power consumption (5)	Reference (2)	Weight kg/lb
4-slot Ethernet + X-bus backplane	BMEP58 processors, Modicon X80 I/O modules (6)	4	4	2.8 W	BMEXBP0400	0.705/ 1.554
8-slot Ethernet + X-bus backplane		8	8	3.9 W	BMEXBP0800	1.060/ 2.337
12-slot backplane (8 Ethernet + X-bus/4 X-bus)		8	12	3.9 W	BMEXBP1200	1.377/ 3.036

Accessories

Description	For use with	Reference	Weight kg/lb
Shielding connection kits comprising: - 1 metal bar - 2 support sub-bases - 1 earthing terminal	BMEXBP0400, BMXXBP0400 rack	BMXXSP0400	0.280/ 0.617
	BMXXBP0600 rack	BMXXSP0600	0.310/ 0.683
	BMEXBP0800, BMXXBP0800 rack	BMXXSP0800	0.340/ 0.750
	BMEXBP1200, BMXXBP1200 rack	BMXXSP1200	0.400/ 0.882
Spring clamping rings Sold in lots of 10	Cables, cross-section 1.5...6 mm ² /AWG 16...10	STBXSP3010	0.050/ 0.110
	Cables, cross-section 5...11 mm ² /AWG 10...8	STBXSP3020	0.070/ 0.154
Protective covers (replacement parts) Sold in lots of 5	Unoccupied slots on BMXXBP rack	BMXXEM010	0.005/ 0.011

(1) Please refer to HMI catalogs on www.schneider-electric.com

(2) In an M580 architecture, Ethernet backplanes can be used for RIO drop Ethernet (EIO) but not as expansion racks anywhere. For expansion rack, it is necessary to use **BMXXBP0400/0600/0800/1200** racks (see page 1/26).

(3) For multi-rack configuration, see page 1/26.

(4) Number of slots including all modules except for power supply rack expansion modules.

(5) Power consumption of anti-condensation resistor(s).

(6) Please refer to the "Modicon X80 I/O platform" catalog on www.schneider-electric.com

Modicon M580 automation platform

Multi-rack configuration

1



Modicon M580 + expansion rack



Modicon X80 drop + expansion rack

Composition of an expansion backplane configuration

M580 CPU supports 4 to 8 local racks (depending upon the CPU performance level), using existing X80 I/O modules and accessories. A Modicon M580 CPU must be installed in the first rack (#0) and this can be a dual bus rack. A Modicon M580 PLC will support up to 7 **BMXXBP●●●●** PV02 or higher backplanes (racks) of 4, 6, 8, or 12 slots. The main backplane (rack #0) will support the CPU.

To expand the configuration using additional racks, users must use a bus expansion module (**BMXXBE1000**) and X-bus cables. The backplane expander will be plugged in the dedicated connector on the right side of the backplane. It will not occupy any module slot. The XBE expansion module will not be hot-swappable in accordance with Modicon X80. Each backplane has to include a power supply module and will support up to 12 modules.

An expansion rack can be connected to the main backplane and the X80 drop (EIO).

The rack address is assigned as follows:

- Each rack will be assigned a physical address using 4 micro switches located in the bus expansion module.
- The main rack containing the CPU will be assigned address 0.
- The other racks will be assigned addresses 1 to 7.

Each rack is equipped with:

- 1 A **BMXCPS●●●●●** power supply
- 2 A **BMXXBE1000** rack expansion module. This module, inserted in the right-hand end of the rack (XBE slot) does not occupy rack slots 00...11 (4, 6, 8, or 12 slots are still available).
- 3 The **BMXXBE1000** rack expansion modules are connected to each other by X-bus cordsets.
- 4 Line terminators: Both expansion modules at the ends of the daisy chain must have a line terminator **TSXTLYEX** on the unused 9-way SUB-D connector.

Ethernet racks

The Modicon M580 CPU supports dual bus backplanes (Ethernet and X-bus), all the processors support Ethernet ring or star architectures on their Ethernet port.

BMXP58●●2● processors support Ethernet star or ring architectures (RSTP loop is supported on ports 2 and 3). The embedded scanner allows scanning of distributed equipment. The CPU drives these devices directly ("NOC" embedded function).

BMXP58●●4● processors support an embedded scanner that allows scanning of X80 drops on Ethernet RIO (EIO) in addition to distributed equipment.

M580 CPUs have an additional third Ethernet port dedicated to the connection of a service tool such as a PC, HMI, or network analyzer. This port is labeled "ETH 1". It does not support RSTP.

M580 CPU will be able to communicate on the main Ethernet backplane. The Modicon M580 CPU cannot be installed in an expansion rack.

It is necessary to use an Ethernet backplane

Reference	Description
BMEXBP0400	Standard 4-slot backplane
BMEXBP0800	Standard 8-slot backplane
BMEXBP1200	Standard 12-slot backplane
BMEXBP0400H	Ruggedized 4-slot backplane
BMEXBP0800H	Ruggedized 8-slot backplane
BMEXBP1200H	Ruggedized 12-slot backplane

Modicon M580 automation platform

Multi-rack configuration

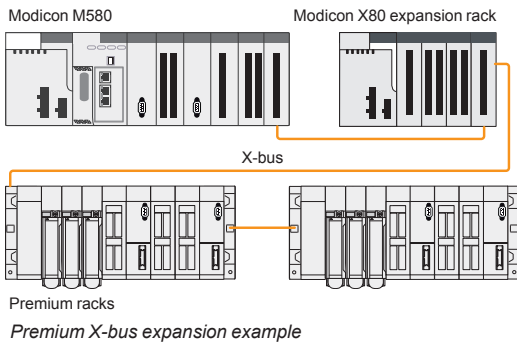

Premium X-bus expansion - making migration as simple as possible

Modicon M580 CPU supports revamping of an existing Premium installation by replacing the Premium rack 0 (CPU and communication modules) with an M580 rack. It is also possible to associate **TSXRKY4EX/6EX/8EX/12EX** Premium racks with X80 I/O based on an X-bus rack. Most existing configurations are supported. The number of expansion racks allowed depends on the CPU that is being used:

- **BMEP581020**, **BMEP582020**, and **BMEP582040** CPUs support a main local rack and up to 3 expansion racks. If you are using 4, 6, or 8-slot Premium expansion racks, you may install 2 physical racks at each assigned rack address, allowing up to 6 Premium expansion racks (up to 6 backplanes and 100 m/328.083 ft. between 2 drops).

- **BMEP583020**, **BMEP583040**, **BMEP584020**, and **BMEP584040** CPUs support a main local rack with up to 7 expansion racks. If you are using 4, 6, or 8-slot Premium expansion racks, you may install 2 physical racks at each assigned rack address, allowing up to 14 Premium expansion racks.

The maximum number of supported X-bus racks is as follows:

- 4 for **BMXXBP●●00**
- 8 for **BMEP58030●0/40●0**

The maximum number of X-bus drops is calculated as follows:

Max number = 1 (CPU rack: **BMXXBP●●00** or **BMEXBP●●00**)
 + ½ number of **TSXRKY4/6/8EX** racks
 + number of **TSXRKY12EX** racks
 + number of **BMXXBP●●00** racks

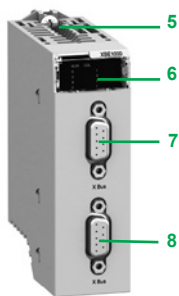

Description

The front panel of the **BMXXBE1000** rack expansion module comprises:

- 5 Retaining screw for locking the module in its slot (at the far right-hand end of the rack)
- 6 A display block with 5 LEDs:
 - RUN LED (green): module in operation
 - COL LED (red): several racks have the same address, or rack address 0 does not contain the **BMEP58●●●0** processor module
 - LEDs 0, 1, 2, and 3 (green): rack address 0, 1, 2, or 3
- 7 A 9-way female SUB-D connector, marked X-bus, for the incoming X-bus cordset 3 connected to the upstream rack, or if it is the first rack, for the **A/** line terminator included in the **TSXTLYEX 4** pack (see page 1/26)
- 8 A 9-way female SUB-D connector, marked X-bus, for the outgoing X-bus cordset 3 to the downstream rack, or if it is the last rack, for the **B/** line terminator included in the **TSXTLYEX 4** pack (see page 1/26)

On the right-hand side panel

A flap for accessing the 3 rack addressing micro-switches: 0...3.

Installation rules for BMXXBP●●●0 racks: For the rules on how to install racks in enclosures, see our website www.schneider-electric.com.

Modicon M580 automation platform

Multi-rack configuration

1

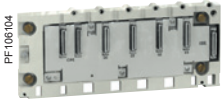

BMXXBP0400

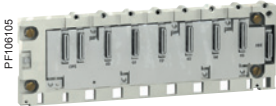

BMXXBP0600

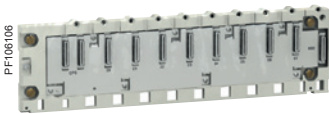

BMXXBP0800

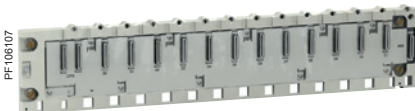

BMXXBP1200



BMXXBE1000

Expansion racks

Description	Type of module to be inserted	No. of slots (1)	Power consumption (2)	Reference	Weight kg/lb
X-bus backplanes for expansion racks (3)	Modicon X80 I/O modules (3) BMEP58 processors	4	1 W	BMXXBP0400	0.630/ 1.389
		6	1.5 W	BMXXBP0600	0.790/ 1.742
		8	2 W	BMXXBP0800	0.950/ 2.094
		12	0 W	BMXXBP1200	1.270/ 2.800

Description	Use	Reference	Weight kg/lb
Modicon X80 I/O rack expansion module (3)	Standard module for mounting in each rack (XBE slot) and used to interconnect: - Up to 3 racks with BMEP581020/20 processor module - Up to 7 racks with BMEP5830 processor module - 1 rack with X80 drop (EIO)	BMXXBE1000	0.178/ 0.392
Modicon X80 I/O rack expansion kit (3)	Complete kit for 2-rack configuration comprising: - 2 BMXXBE1000 rack expansion modules - 1 BMXXBC008K extension cordset, length 0.8 m/2.625 ft. - 1 TSXTLYEX line terminator (set of 2)	BMXXBE2005	0.700/ 1.543

(1) Number of slots taking all modules except for power supply and rack expansion modules

(2) Power consumption of anti-condensation resistor(s)

(3) Please refer to the "Modicon X80 I/O platform" catalog on www.schneider-electric.com.



PF108142

BMXXBC●●●K

Cordsets and connection accessories

Description	Use	Composition	Type of connector	Length m/ft.	Reference	Weight kg/lb				
X-bus extension cordsets total length 30 m/98.425 ft. max.	Between 2 BMXXBE1000 rack expansion modules	2 x 9-way SUB-D connectors	Angled	0.8/2.625	BMXXBC008K	0.165/ 0.364				
				1.5/4.921	BMXXBC015K	0.250/ 0.551				
				3/9.842	BMXXBC030K	0.420/ 0.926				
				5/16.404	BMXXBC050K	0.650/ 1.433				
				12/39.37	BMXXBC120K	1.440/ 3.175				
							Straight	1/3.281	TSXCBY010K	0.160/ 0.353
								3/9.842	TSXCBY030K	0.260/ 0.573
								5/16.404	TSXCBY050K	0.360/ 0.794
								12/39.37	TSXCBY120K	1.260/ 2.778
								18/59.05	TSXCBY180K	1.860/ 4.101
			28/91.86	TSXCBY280KT (1)	2.860/ 6.305					
Cable reel	Length of cable to be equipped with TSXCBYK9 connectors	Cable with ends with flying leads, 2 line testers	—	100/328.08	TSXCBY1000	12.320/ 27.161				



PF108138

TSXTLYEX

Description	Use	Composition	Type of connector	Sold in lots of	Unit reference	Weight kg/lb
Line terminators	Required on the 2 BMXXBP●●●0 modules located at either end of the daisy chain	2 x 9-way SUB-D connectors marked A/ and /B		2	TSXTLYEX	0.050/ 0.110
X-bus straight connectors	For TSXCBY1000 cables	2 x 9-way SUB-D straight connectors		2	TSXCBYK9	0.080/ 0.176
Connector assembly kit	For attaching TSXCBYK9 connectors	2 crimping pliers, 1 pen (2)		—	TSXCBYACC10	—

(1) Cable supplied with a set of 2 TSXTVSY100 electrical transient suppressors.

(2) To fit the connectors on the cable, you also need a wire stripper, a pair of scissors, and a digital ohmmeter.

Architectures

Overview of I/O architectures..... page 2/2

- Presentation page 2/4
- Architecture A..... page 2/5
- Architecture B..... page 2/6
- Architecture C..... page 2/7
- Architecture D..... page 2/8
- Modicon X80 performance EIO adapter..... page 2/9
- Modbus/TCP and EtherNet/IP network module..... page 2/10
- Modicon X80 NRP EIO drop optical repeaters page 2/11
- ConneXium managed switches..... page 2/11
- Example of a complex architecture..... page 2/12
- Examples of architectures..... page 2/13
 - Food and beverage examples..... page 2/13
 - Water example page 2/14
 - Hydro power example page 2/15
 - Cement example page 2/16
- References and requirements..... page 2/17

Modicon distributed I/O solutions

Selection guide page 2/20

- Presentation..... page 2/22
- Description, references..... page 2/23
- Composition page 2/24
- Configuration page 2/25

Modicon M580 automation platform

I/O architectures

Modicon M580 type of architecture
 Note: These architectures can be combined with each other

Architectures with local racks (main rack and expansion racks)	
Hardwired	Distributed peripherals over fieldbuses
Compact topology with devices hardwired on local I/O	Compact topology with devices distributed over fieldbuses
Architecture A	Architecture B

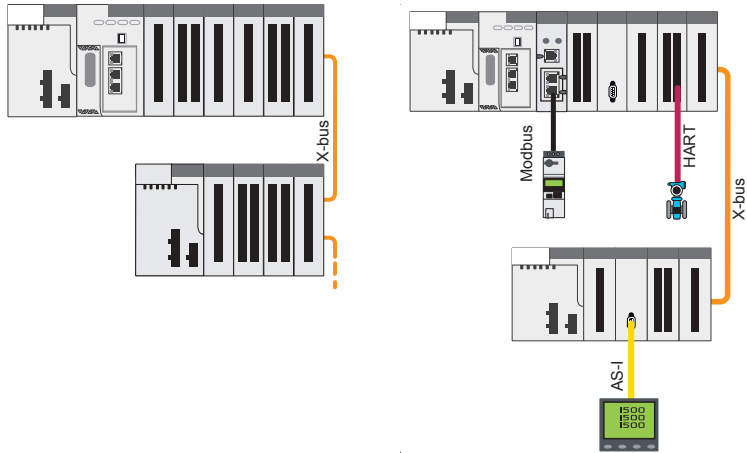

Architecture with local racks (main rack and expansion racks)	Architecture with racks in remote drops
Distributed peripherals and I/O over Ethernet	Remote over Ethernet
Distributed devices and I/O topology over Ethernet	Remote I/O + Remote functions (including fieldbus master)
Architecture C	Architecture D

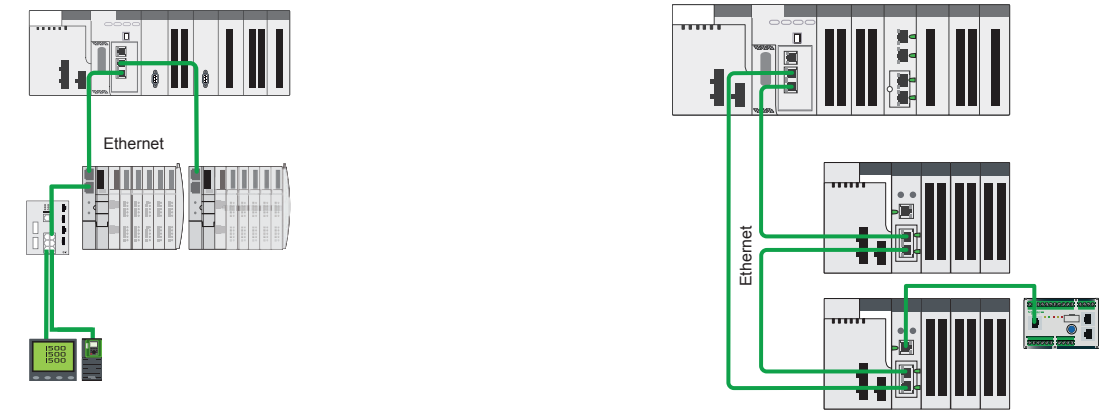

Expanded rack (with X-bus rack expansion module)		Main local rack with up to 7 local expansion racks on X-bus (Modicon Premium or Modicon X80 racks)
Backplane compatibility	BMEXBP●●00 Ethernet + X-bus racks BMXXBP●●00 X-bus racks PV02 (or later)	Compatible for main racks (local or remote)
Compatible CPU types		Mandatory for expansion racks (main or remote) Compatible with any rack if Modicon X80 I/O Ethernet modules are not used in the racks, such as: weighing, HART and BMXCRA31210 modules
CPU Ethernet ports	SERVICE port Dual port	All CPUs are compatible (1) One SERVICE port for HMI, Unity, control network, variable speed drive, etc. Dual ports are not used
RIO drops		-
Communication	AS-Interface and serial link modules BMXNOR0200H RTU module Ethernet modules	Yes Yes Yes
Expert functions	PTO (Pulse Train Output) modules Other expert modules: counting, SSI encoder, etc.	Yes Yes
Time stamping	1 ms max. BMXERT1604T module integrated in the ERT module 10 ms with BMXCRA31210 combined with discrete I/O modules in the RIO drop	Yes -
Pages		

(1) BMPE58●●40 CPUs are not mandatory for architectures A, B and C.
 (2) BMXCRA31210 modules are also compatible.

Main local rack with up to 7 local expansion racks on X-bus (Modicon Premium or Modicon X80 racks)		Main local rack with up to 7 local expansion racks on X-bus (Modicon Premium or Modicon X80 racks), RIO drop with up to 1 remote expanded rack on X-bus (only Modicon X80 racks)
Compatible for main racks (local or remote)		
Mandatory for expansion racks (main or remote) Compatible with any rack if Modicon X80 I/O Ethernet modules are not used in the racks, such as: weighing, HART and BMXCRA31210 modules		
All CPUs are compatible (1)		BMEP58●●40 CPUs are required to manage RIO
One SERVICE port for HMI, Unity, control network, variable speed drive, etc.		
Dual ports are used for distributed equipment (DIO scanner)		Dual ports are used for remote equipment (RIO scanner), BMXCRA31210 Ethernet drop adapter is mandatory in RIO drop (2).
-		A maximum of 16 RIO drops can be supported in an M580 network
Yes		Yes, in a local rack or in a RIO drop
Yes		Yes, only in a local rack
Yes		Yes, only in a local rack
Yes		Yes, only in a local rack
Yes		Yes, in a local rack or in a RIO drop
Yes		Yes, in a local rack or in a RIO drop
-		Yes, only in the RIO drop, system mode with OFS (2)

Presentation

The Modicon M580 automation platform offers four different types of architectures with local racks or with racks in remote drops. These four options are presented on the following pages as architectures A, B, C and D. The Modicon M580 automation platform offers an I/O architecture solution over local racks, fieldbuses and Ethernet, connecting the M580 main rack to remote I/O (RIO) drops, installed on a Modicon X80 rack (1), and distributed I/O (DIO) devices.

This Modicon M580 solution comprises:

- RIO drops on a Modicon X80 drop
- Ethernet DIO devices
- A choice of three CRA Ethernet drop adapters (standard or high performance) in each Modicon X80 RIO drop
- Two optical repeaters, for single mode or multimode optical fiber, on Modicon X80 RIO drop
- A choice of three types of managed dual ring switches (DRS) from the ConneXium offer (2), configurable by means of predefined configuration files for immediate setup

Different architectures are therefore possible, such as:

- Ethernet RIO architectures with or without ConneXium managed switches (2)
- Architectures with separate or combined Ethernet RIO and Ethernet DIO devices on the same physical medium

This solution also includes numerous options and functions as standard, providing:

- High process availability, with the option of connecting Ethernet RIO and Ethernet DIO in a daisy chain loop
- Deterministic data exchanges between the PLC and the Ethernet RIO
- Remote service, with a SERVICE port available on the M580 CPU or Modicon X80 CRA Ethernet drop adapters

Note

■ The validated and tested architectures are shown in the technical documentation available on our website www.schneider-electric.com.

■ The use of switches other than those detailed in these architecture I/O pages (pages 2/4 to 2/19) is not supported (2).

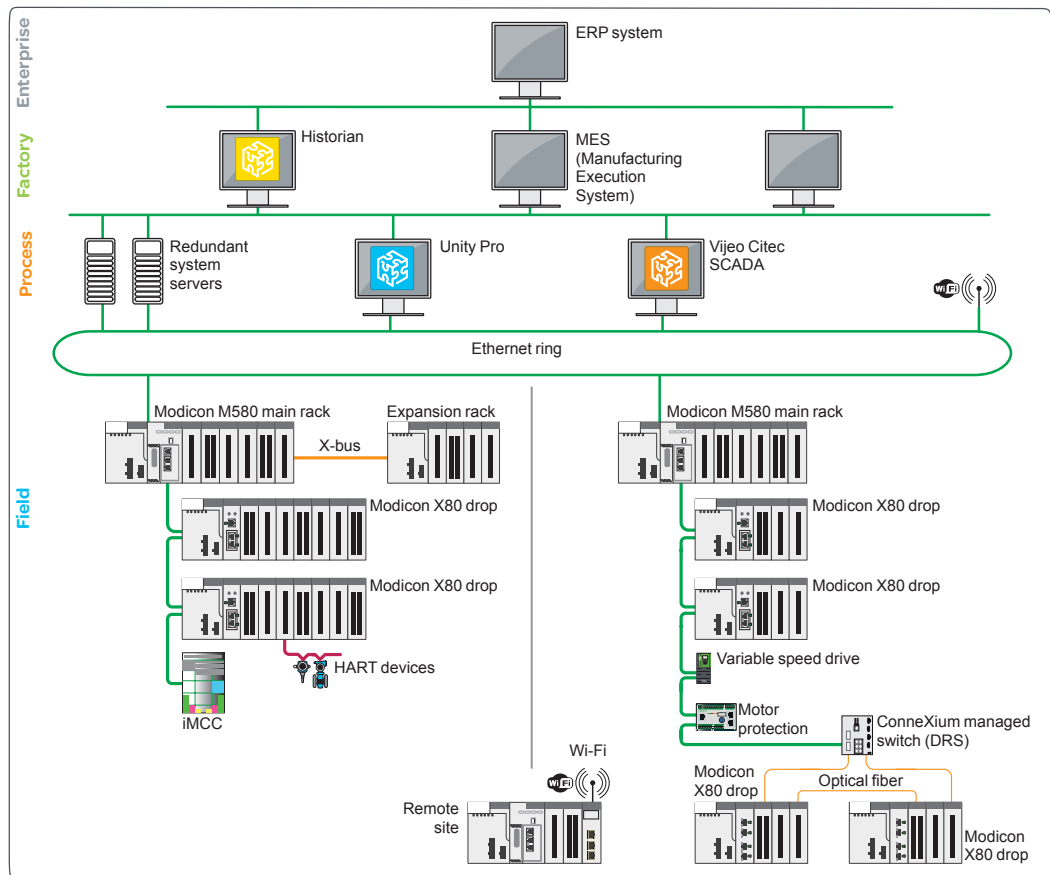

Typical architecture (3)

(1) The Modicon X80 range offers common I/O modules which can be used both in Ethernet RIO drops connected in Modicon M580 automation platforms.

(2) Supported ConneXium switches: TCSESM083F23F1/063F2CU1/063F2CS1 (see page 2/11).

(3) This typical architecture representation is a conceptual network diagram and does not represent the actual wiring specifications.

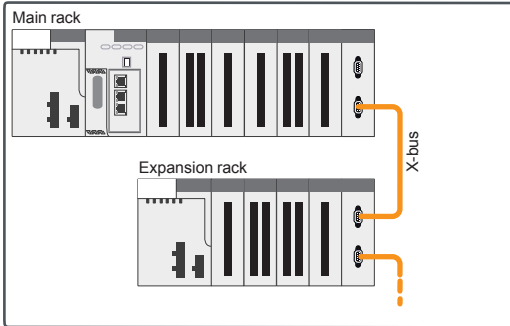

Architecture A: devices on local I/O

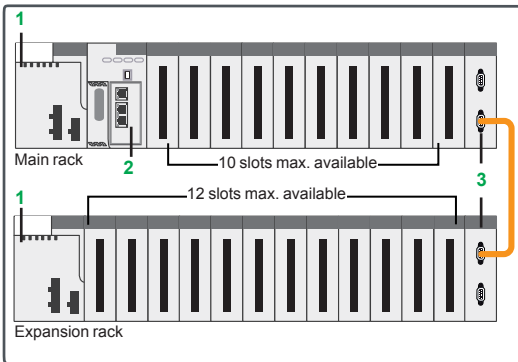

For rack accessory references, see page 1/25

Presentation

Architecture A is used for control systems that reside in the main control cabinet. The M580 platform provides interrupt services for this type of application. Up to 94 slots are possible for I/O modules in a configuration comprising a main rack and 7 expansion racks, connected by **BMXXBE●00●** rack expansion modules.

Description

The Modicon M580 automation platform provides local I/O management for control systems that are wired to the main control cabinet.

Architecture A can comprise a maximum of 10 I/O modules in the main rack, in addition to the CPU module **1** and the power supply module **2**. These local I/O can be extended on an expansion rack by using a **BMXXBE●00●** rack expansion module **3**.

Ethernet slots are available only in the main rack because rack expansion cables only support X-bus.

The choice of appropriate rack depends on the required number of modules for the system. Main racks are available in the following formats: 4, 8 and 12 slots.

As well as discrete and analog I/O modules, the following modules are available:

- Application-specific modules:
 - SSI encoder
 - Counter
 - Pulse train output
 - Weighing

Some application-specific modules (weighing, etc.) require use of an Ethernet backplane.

If necessary, communication and network modules can be installed in the local rack. The majority of communication and network modules need to be in the local rack.

Architecture A configuration rules

When configuring an architecture A system, the following four parameters should be considered:

- Number of slots available in the 8 local racks (main and expansion racks)
- Slots available for optional modules
- Power consumed by the installed modules
- Addressing words available for configuring the modules

Available slots and power consumption

Architecture A can have a maximum of 94 available slots (with eight 12-slot racks) for I/O modules, application-specific modules and communication modules.

These modules are powered from the power supply included in the rack.

For a valid configuration, simply add together the consumption (in mA) of the modules in the rack and check that the total current is less than that provided by the selected power supply.

This power consumption calculation can easily be performed using Unity Pro software.

Empty **BMXXEM010** modules are also available to occupy unused slots.

Module addressing (1)

With Unity Pro, the I/O addressing is unlimited (physical limitation: 94 slots).

(1) Requires Unity Pro software V8.0.

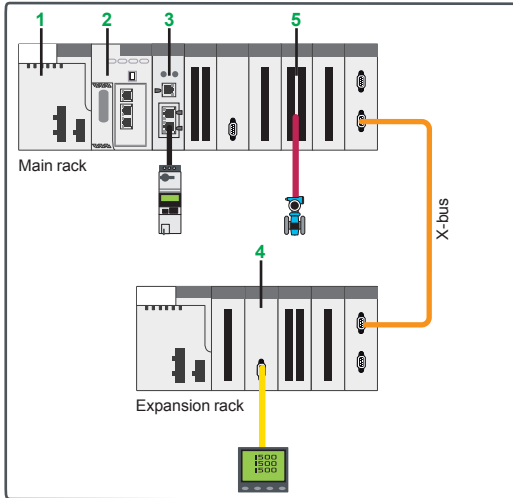

Architecture B: devices distributed over fieldbuses

Presentation

Architecture B is based on architecture A with the possibility of adding fieldbuses such as AS-Interface, Modbus SL, HART, etc.

Architecture B is used for control systems that are wired to the main control cabinet. It consists of a mainly local topology with several peripherals distributed over fieldbuses.

The Modicon M580 automation platform provides interrupt services for this type of application.

Up to 94 slots are possible for I/O and communication modules in a configuration comprising a main rack and 7 expansion racks, connected by **BMXXBE●00●** rack expansion modules.

Description

The Modicon M580 automation platform provides local I/O management for control systems that are wired to the main control cabinet.

Architecture B can comprise a maximum of 10 I/O and communication modules in the main **BMEXBP●●00** rack, in addition to the CPU module **2** and the power supply module **1**. These local I/O and communication modules can be extended on expansion racks by using a **BMXXBE●00●** rack expansion module.

The choice of appropriate racks depends on the required number of modules for the system. Main racks are available in the following formats: 4, 8 and 12 slots.

If necessary, communication and network modules can be installed in the main rack. The majority of communication and network modules need to be in the main rack.

As well as discrete and analog I/O modules, the following modules are available:

- Communication modules:
 - Serial link **3**
 - AS-Interface **4**
 - HART **5**

Some communication modules (Modbus/TCP and EtherNet/IP network module, HART analog I/O modules, etc.) require use of an Ethernet backplane.

Architecture B configuration rules

When configuring an architecture B system, the following four parameters should be considered:

- Number of slots available in the 8 local racks
- Slots available for optional modules
- Power consumed by the installed modules
- Addressing words available for configuring the modules

Available slots and power consumption

Architecture B can have a maximum of 94 available slots (with eight 12-slot racks) for I/O modules, application-specific modules and communication modules.

These modules are powered from the power supply included in the rack.

For a valid configuration, simply add together the consumption (in mA) of the modules in the rack and check that the total current is less than that provided by the selected power supply.

This power consumption calculation can easily be performed using Unity Pro software.

Empty **BMXXEM010** modules are also available to occupy unused slots.

Module addressing

With Unity Pro (1), the I/O addressing is unlimited (physical limitation: 94 slots).

(1) Requires Unity Pro version ≥ 8.0 software.

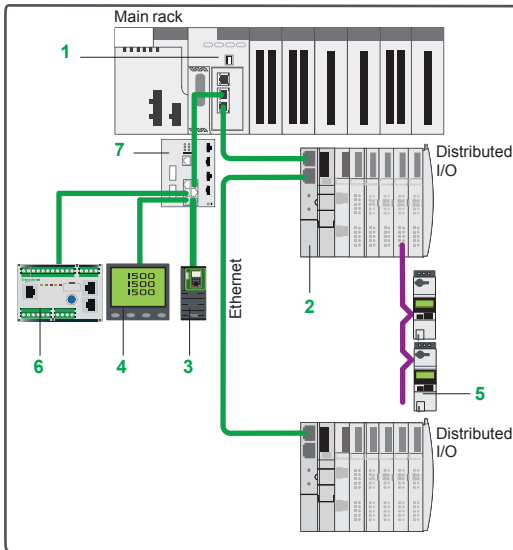

Architecture C: devices distributed over Ethernet

Presentation

Architecture C consists of I/O and devices distributed over Ethernet (DIO).

The Ethernet DIO devices can be connected to Ethernet ports of the **BMEP58●0●0** CPU **1** or of a ConneXium DRS (Dual Ring Switch) switch.

The available Ethernet DIO devices are:

- Modicon STB distributed I/O **2**
- Variable speed drives **3**
- Energy supervision **4** and HMI
- Tesys U **5** connected via CANopen to a Modicon STB I/O island and Tesys T **6** motor protection, etc.

Modbus serial link devices can be integrated in architecture C via the **BMXNOM0200** serial link module.

High availability and expanded integration capacity

Architecture C can integrate ConneXium DRS (Dual Ring Switch) switches **7 (1)**. 15 predefined configurations which can be loaded into the switches simplify their implementation.

The use of these switches provides enhanced capacity for the integration of devices:

- DIO sub-rings
- DIO clouds

The advantages of this architecture are:

- High availability of the Ethernet DIO devices

Maximum distance between each ConneXium managed switch:

- 100 m/328.084 ft with copper medium
- 2 km/1.243 mi with multimode optical fiber
- 16 km/9.942 mi with single mode optical fiber medium

(1) Supported ConneXium switches: TCSESM083F23F1, TCSESM063F2CU1, TCSESM063F2CS1.

Modicon M580 automation platform

Architectures with remote racks Architecture D

2

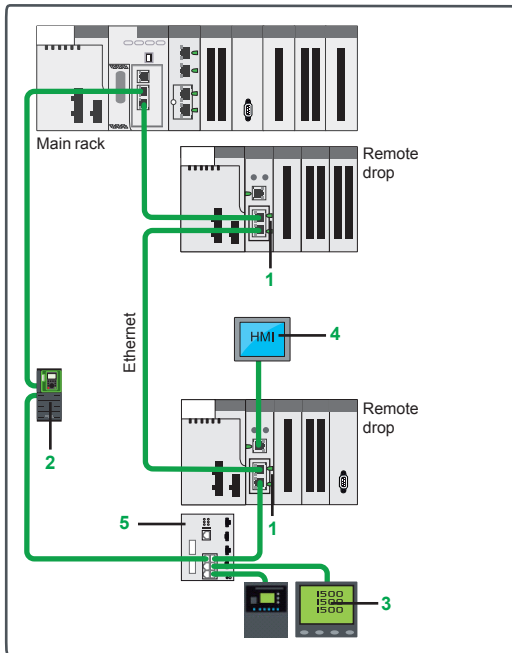

Architecture D: remote I/O

Presentation

Architecture D consists of remote I/O and remote functions (including fieldbus masters).

Architecture D is fully compatible with the references in the Modicon M580 automation platform and Modicon X80 I/O platform offers. The capacity of Modicon X80 I/O drops depends on the CRA Ethernet drop adapter used. A maximum of 16 RIO drops **1** can be supported in an architecture D system.

The available Ethernet devices are:

- Variable speed drives **2**
- Energy supervision **3** and HMI **4**
- Tesys T motor protection, etc.

It is possible to include DIO devices in architecture D via the SERVICE port of the CPU or of the **BMECRA31210** drop adapter **1** or via ConneXium DRS (Dual Ring Switch) switches **5**.

Rack Viewer function ▲

The Rack Viewer function provides access to Ethernet RIO data via a web browser.

Predefined configurations for ConneXium managed switches

The use of ConneXium managed switches specifically for Modicon M580 architectures is simplified using 15 predefined configuration files.

Standard architecture D

This is composed of a daisy chain loop consisting of a Modicon M580 main rack and several Modicon X80 I/O drops containing an Ethernet drop adapter:

- **BMECRA31210** Modicon X80 performance EIO adapter, with SERVICE port
- **BMXCRA31210** Modicon X80 RIO Ethernet drop adapter, with SERVICE port
- **BMXCRA31200** Modicon X80 RIO Ethernet drop adapter, without SERVICE port

Long distance architecture D

Similar to the standard architecture D, this variant comprises of one or more remotely located Modicon X80 I/O drops connected via integrated NRP optical fiber repeaters.

There are two types of NRP repeater:

- **BMXNRP0200**: multimode optical fiber repeater (remote location up to 2 km)
- **BMXNRP0201**: single mode optical fiber repeater (remote location up to 16 km)

The NRP repeaters are linked to CRA drop adapters by means of Ethernet Interlink cables.

High availability and expanded integration capacity

Architecture D can integrate ConneXium DRS (Dual Ring Switch) switches **5** (1). 15 predefined configurations which can be loaded into the switches simplify their implementation.

The use of these switches provides enhanced capacity for the integration of devices:

- RIO sub-rings
- Optical fiber media for long distance remote location, etc.
- Enable DIO integration to architecture D

The advantages of this architecture are:

- Reduced wiring costs
- Deterministic data exchanges between the PLC and the EIO devices
- Secondary rings can be linked to the main ring by two DRS switches, which improve availability

Maximum distance between each ConneXium managed switch:

- 100 m/328.084 ft with copper (twisted pair) cables
- 2 km/1.243 mi with multimode optical fiber
- 16 km/9.942 mi with single mode optical fiber media

▲ Available 2nd quarter 2014.

(1) Supported ConneXium switches: TCSESM083F23F1, TCSESM063F2CU1, TCSESM063F2CS1.



BMECRA31210

Modicon X80 performance EIO adapter

Presentation

An M580 Ethernet RIO (EIO) architecture with Modicon X80 I/O drops requires the use of a dedicated adapter in each Modicon X80 drop.

The **BMECRA31210** adapter supports Ethernet and X-bus communications across the remote backplane.

This EIO adapter module supports several expert modules such as counting and weighing modules and CCOTF (Change Configuration On The Fly).

For Modicon X80 RIO drops on an Ethernet backplane, time stamping can be managed with a resolution of 10 ms when using a **BMECRA31210** performance EIO adapter.

Only one **BMECRA31210** module can be installed per Modicon X80 RIO drop.

This module can also support a BMXXBP●●00 expansion rack.

The **BMECRA31210** adapter is designed to be installed on an Ethernet backplane in the main remote rack. The adapter supports the Modicon X80 I/O and partner modules with both Ethernet and X-bus connections (1).

The keying pin on the rear side of the module means the **BMECRA31210** adapter cannot be installed on unsupported backplanes.

These adapters are connected by Ethernet cordsets fitted with RJ45 connectors. The dual Ethernet connection port on each adapter allows Daisy Chain Loop connections using the RSTP protocol (Rapid Spanning Tree Protocol).

The **BMECRA31210** adapter is also available in a conformal coating version for harsh environments.

It also complies with several standards and certifications such as C-Tick, GOST, merchant navy, CSA C22.2 No. 142 and 213 and IEC/EN 61131-2.

Capacity of the Modicon BMECRA31210 adapter

Maximum number of racks per drop	Up to 2
SERVICE port	1
Discrete I/O modules	Up to 1024
Analog I/O module	Up to 256
Expert modules supported:	<ul style="list-style-type: none"> ■ serial link BMXNOM0200 ■ time and date stamping at 1 ms BMXERT1604T ■ counting BMXEHC0200/BMXEHC0800 ■ weighing PMESWT0100 ■ HART integrated analog I/O modules BMEAHI0812/BMEAHO0412
CCOTF function	Yes
Time and date stamping	10 ms

Description

- 1 LED display block indicating the module status
- 2 Rotary switches for setting the address of an EIO drop (00...159)
- 3 Dedicated RJ45 service port (ETH 1) for remote service tools such as a PC, an HMI terminal module or Ethernet DIO devices
- 4 RJ45 device network port (ETH 2) for connection to the Ethernet network
- 5 RJ45 device network port (ETH 3) for connection to the Ethernet network

(1) This module is also compatible with X-bus backplanes. In this case it has the same functionality as a **BMXCRA31210** performance Ethernet drop adapter.

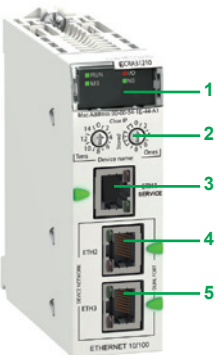

BMECRA31210



BMXNOC0402

Presentation

The **BMXNOC0402** (1) network module acts as an interface between the M580 PLC and other Ethernet network devices via the Modbus/TCP and EtherNet/IP communication protocols.

The standard format **BMXNOC0402** network module occupies a single slot in the rack of the Modicon M580 platform. This module should be installed in the main Ethernet backplane rack.

Functions

The **BMXNOC0402** module offers the following functions:

- Modbus/TCP and EtherNet/IP protocols operating simultaneously
- Ring topologies on 2 Ethernet ports using RSTP (Rapid Spanning Tree Protocol)
- Priority of Ethernet packets using QoS (Quality of Service) service
- Automatic module configuration recovery using FDR (Fast Device Replacement) service
- Embedded Web server for application monitoring and module diagnostics
- Sharing data between PLCs
- Network management using SNMP (Simple Network Management Protocol)

Description

The front panel of the **BMXNOC0402** module features:

- 1 A screw for locking the module in a slot in the rack.
- 2 A display block with 5 LEDs:
 - RUN LED (green): Operating status
 - ERR LED (red): Error detected
 - MS LED (green/red): Module status
 - NS LED (green/red): Network connection status
 - ETH STS LED (amber): Ethernet link status
- 3 Four RJ45 connectors for connection to the Ethernet network. The two bottom connectors **3a** support ring topologies (RSTP protocol).

Each RJ45 connector has two associated LEDs:

- LNK LED (yellow): Ethernet link established
- ACT LED (green): Transmission/reception activity

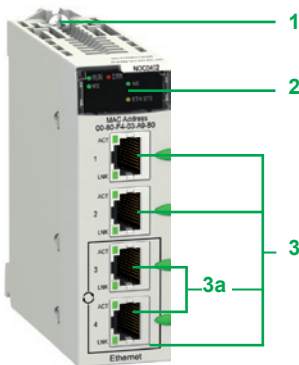

BMXNOC0402

Combination of Ethernet modules and BMEP58 CPU

It is possible to combine Ethernet modules with the Modicon M580 CPU in order to increase its connectivity.

In this example, the two NOC EtherNet/IP, Modbus/TCP network modules **5** are linked to the BMEP58•0•0 CPU module **4** by means of Ethernet Interlink cables **6**. Multiple combinations are possible:

- 4 **BMEP581020** CPU
- 5 **BMXNOC0402** EtherNet/IP, Modbus/TCP network module
- 6 Ethernet Interlink cable **TCSECN3M3M1S4/1S4U**

(1) The **BMXNOC0402** communication module will be replaced by the **BMENOC03•1** modules during the 2nd quarter of 2014.

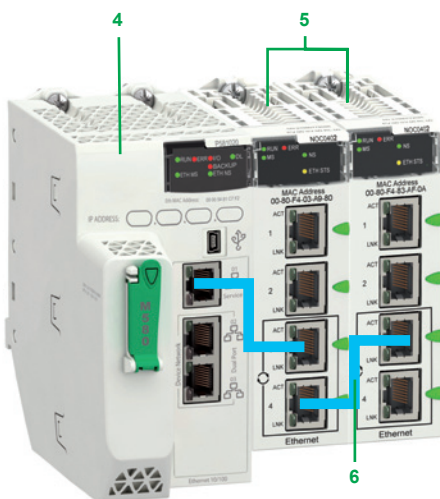

Example of BMEP58 and NOC module combination:
BMEP581020/BMXNOC0402/BMXNOC0402

Modicon M580 automation platform

Modicon X80 NRP EIO drop optical repeaters,
ConneXium managed switches

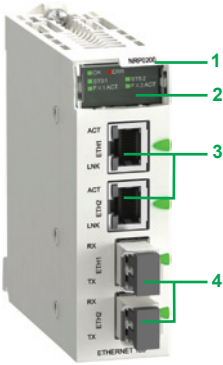

BMXNRP020●

Modicon X80 EIO drop optical repeaters (1)(2)

Presentation

BMXNRP0200/0201 optical fiber repeaters are an alternative to the use of ConneXium managed dual ring switches (DRS), for optical fiber communications over long distances, in Ethernet I/O (EIO) systems.

When inserted in Modicon X80 RIO drops, **BMXNRP0200/0201** optical fiber repeaters make it possible to:

- Extend the total distance of the EIO network, when EIO drops are located in areas of the factory more than 100 m/328.084 ft away
- Enhance immunity to noise
- Resolve difference of potential between distant sites
- NRP repeaters can be installed on the primary ring or on secondary rings. These modules cannot, however, be used to connect secondary rings to the primary ring
- The **BMXNRP0200** repeater for multimode optical fiber allows remote location up to 2 km/1.243 mi.

The **BMXNRP0201** repeater or single mode optical fiber allows remote location up to 16 km/9.942 mi.

Depending on the configuration, the NRP repeater may be linked to the CRA adapter of the drop where it is installed, via one or two Ethernet Interlink cables.

Description

- 1 Module reference
- 2 Display block indicating the module status
- 3 RJ45 Ethernet ports. Two LEDs, LNK and ACT, indicate the status of each port
- 4 Optical fiber ports with SFP transceiver for LC type connector

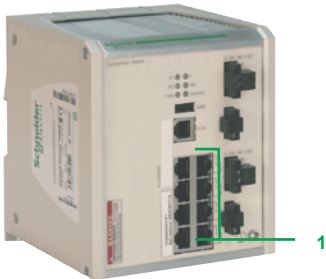

TCSESM083F23F1

ConneXium managed switches (3)

Presentation

There are three ConneXium managed DRS (Dual Ring Switch) models available specifically for EIO architectures. They are used in the following situations:

- For remote racks located at a distance of more than 100 m/328.084 ft
- Use of optical fiber media:
 - For remote racks located over long distances: 2 km/1.243 mi (multimode optical fiber) or 16 km/9.942 mi (single mode optical fiber)
 - In environments subject to interference
 - Between sites with different earth equipotentiality
- Architectures with combined EIO and Ethernet DIO devices
- Implementation of a secondary ring

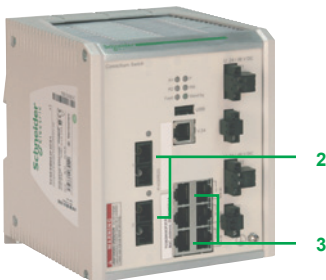

TCSESM063F2CU1
TCSESM063F2CS1

ConneXium managed switches specific to the medium

ConneXium managed switch	Copper port	Multimode optical fiber port	Single mode optical fiber port	Distance between switches
	RJ45 shielded connectors	Duplex SC connectors		
TCSESM083F23F1	1 : 8 x 10/100 BASE-TX ports	–	–	100 m/ 328.084 ft
TCSESM063F2CU1	3 : 6 x 10/100 BASE-TX ports	2 : 2 x 10/100 BASE-FX ports	–	2 km/ 1.243 mi
TCSESM063F2CS1	3 : 6 x 10/100 BASE-TX ports	–	2 : 2 x 10/100 BASE-FX ports	16 km/ 9.942 mi

Predefined configuration files

For ease of implementation of the 3 switches described above, 15 predefined configuration files are available for building validated and tested architectures. These configuration files are included, as standard, on the Unity Pro V8.0 DVD. The parameters of the switch(es) present on the Ethernet network can then easily be easily set with the chosen configuration using a PC equipped with a web browser or Ethernet Switch Configurator software. The switch is configured immediately. Ethernet Switch Configurator software is also available on the ConneXium Resource CD-ROM.

(1) For additional characteristics, see our website www.schneider-electric.com.

(2) Requires Unity Pro Extra Large software ≥ V8.0.

(3) The functions described are only available for the three ConneXium managed switches mentioned on this page: (TCSESM083F23F1/063F2CU1/063F2CS1).

Example of a complex architecture

The complex architecture below illustrates the extensive possibilities of the Modicon M580 offer:

- A choice between 7 BMEP580●0●0 CPUs **1**
- Easy integration of the I/O network with supervisors in the control network, due to the **BMXNOC0402** Ethernet module **2** (1)
- Optimized wiring with RIO and DIO control via a single medium: the DIO are controlled via the CPU
- High availability of secondary rings with ConneXium managed switches **3**
- Long distance optimized by the optical fiber converter **4**, directly in the Modicon X80 rack
- Simplified integration of devices via a serial link **5** (for example: measuring center, variable speed drive, motor starters, protection relays, etc.). FTD/DTM technology makes it possible to configure and debug devices transparently via the Ethernet network, from any supervisor
- Great flexibility due to integration of DIO devices **6** or other diagnostic/configuration tools on any drop SERVICE port or on the DIO port of a managed switch
- Easy integration of Modicon X80 I/O drops on Ethernet with BMECRA31210 drop adapters **7**

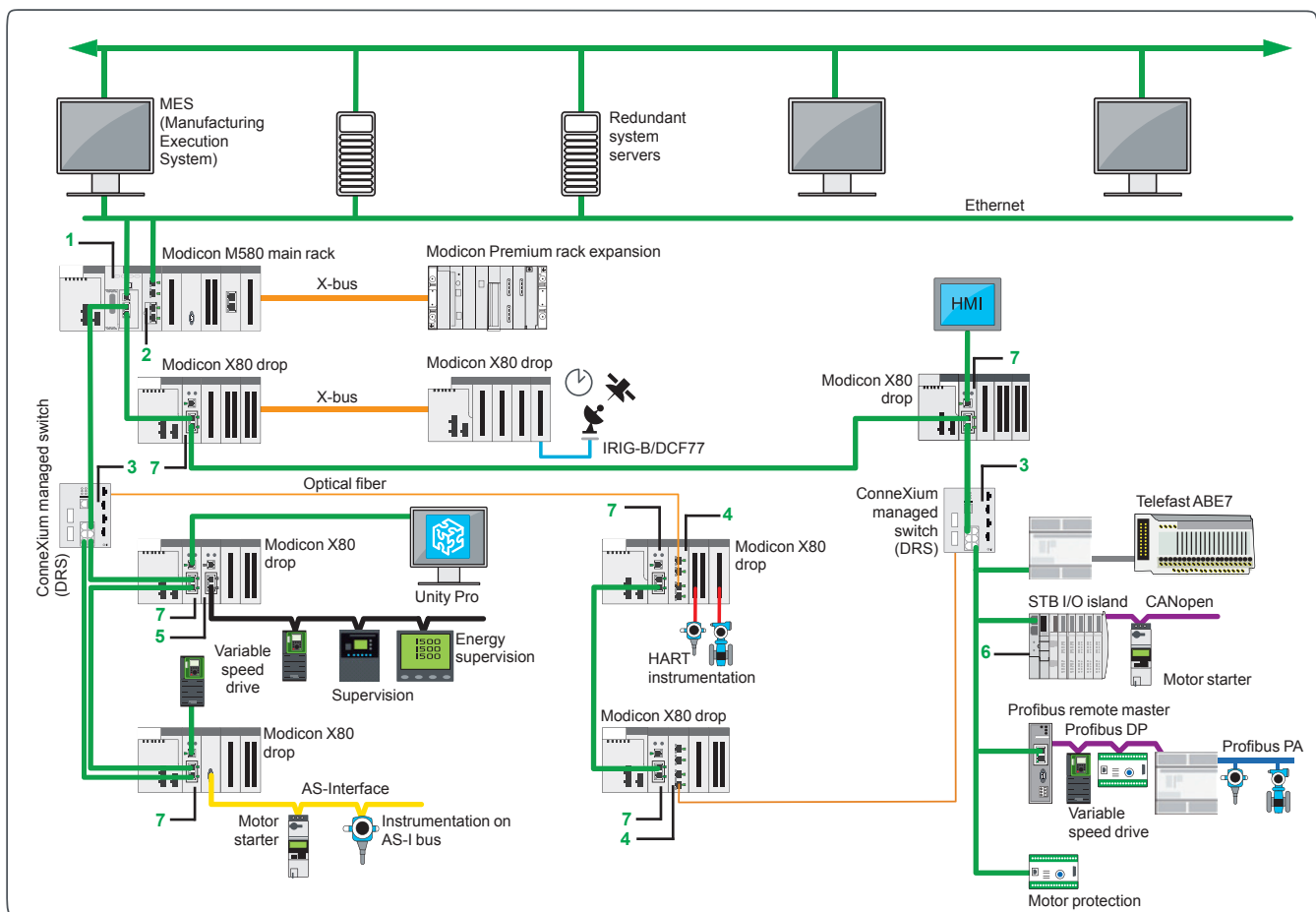

Example of a complex architecture

(1) The BMXNOC0402 communication module will be replaced by the BMENOC03●1 modules during the 2nd quarter of 2014.

Modicon M580 automation platform

I/O architectures

Example of an architecture

Example of an architecture for Food & Beverage applications

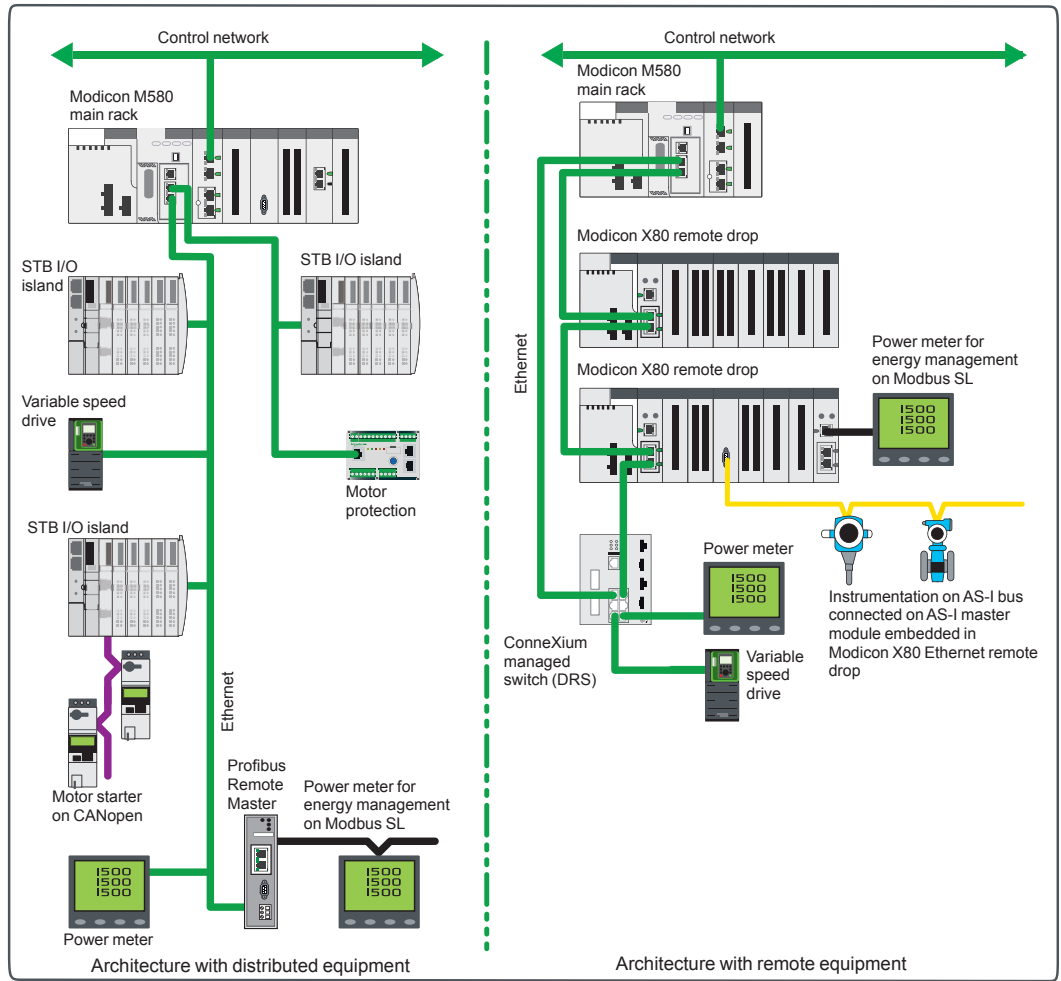

2

Example of an architecture: Food & Beverage application

Note: These architecture representations are conceptual network diagrams and do not represent actual wiring specifications.

Modicon M580 automation platform

I/O architectures

Example of an architecture

2

Example of an architecture for a Water application

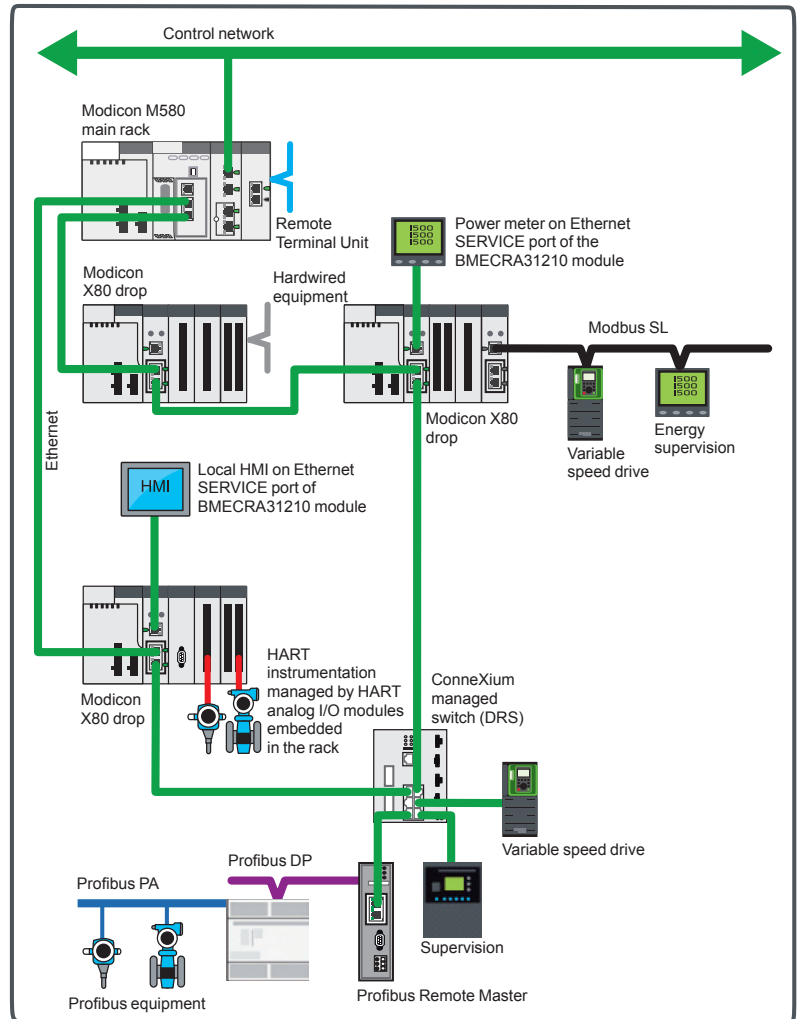

Example of an architecture: Water application

Modicon M580 automation platform

I/O architectures

Example of an architecture

Example of an architecture for a Hydro power application

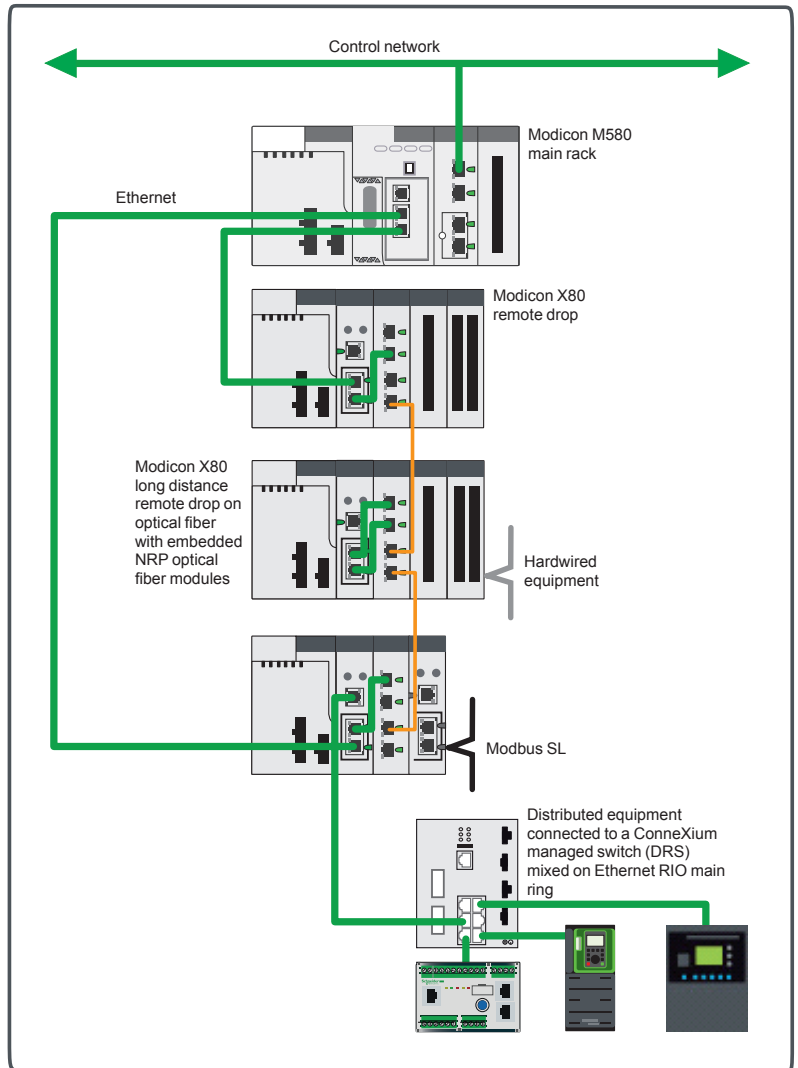

Example of an architecture: Hydro power application

Modicon M580 automation platform

I/O architectures

Example of an architecture

2

Example of an architecture for a Cement application

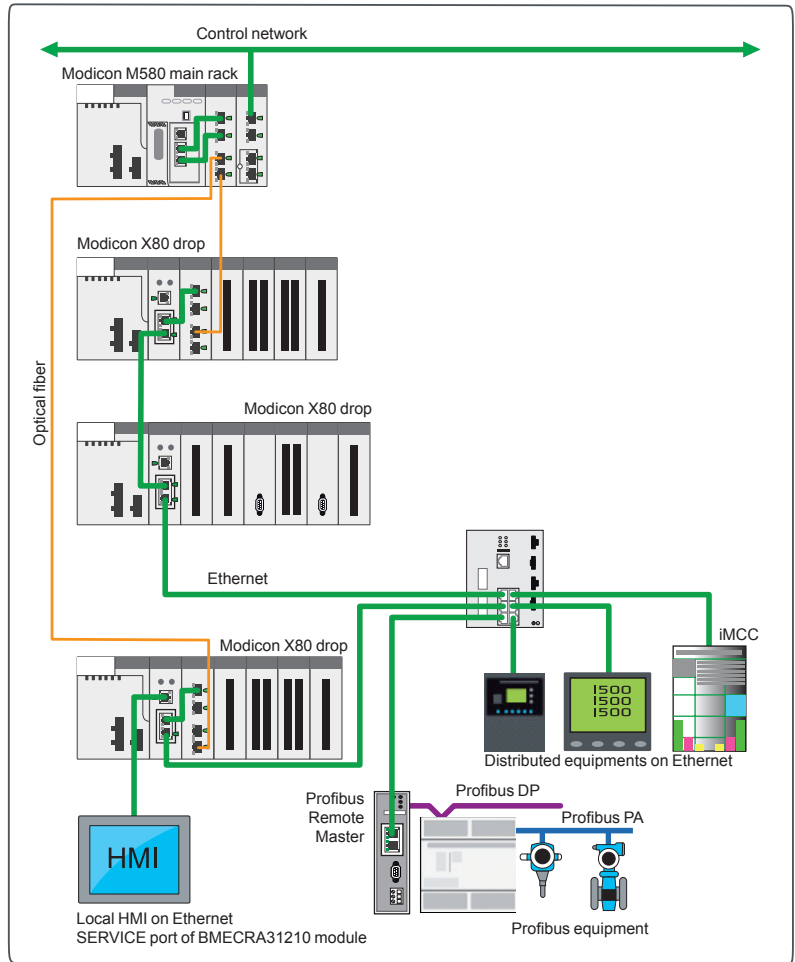

Example of an architecture: Cement application

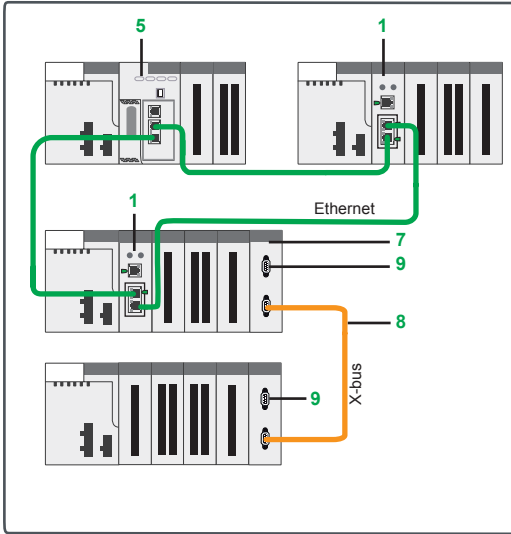

Architecture A + architecture D

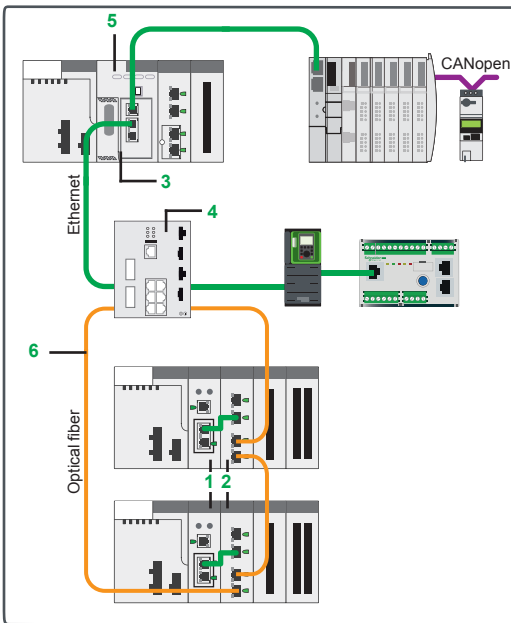

Architecture C + architecture D

References (1)

Ethernet head and drop adapters (2)

Description	SERVICE port	Item (3)	Reference	Weight kg/lb
Modicon X80 EIO drop adapter	–	1	BMXCRA31200	0.200/ 0.441
Provide 1 module per Modicon X80 EIO drop	1	1	BMXCRA31210 (4)	0.234/ 0.516
	1	1	BMECRA31210 (4)	0.234/ 0.516

Modicon X80 Ethernet RIO drop optical repeaters (2)

Description	Optical fiber	Item (3)	Reference	Weight kg/lb
Modicon X80 Ethernet RIO drop optical repeaters	multimode	2	BMXNRP0200	0.203/ 0.448
	single mode	2	BMXNRP0201	0.203/ 0.448

Ethernet communication modules and cordsets (2)

Description	Item (3)	Reference	Weight kg/lb	
Modbus/TCP and EtherNet/IP network module	3	BMXNOC0402 (5)	0.200/ 0.441	
Ethernet Interlink cables	Standard version	–	TCSECN3M3M1S4	–
Length 1 m/3.281 ft	UL version	–	TCSECN3M3M1S4U	–

Dedicated ConneXium managed switches (5)(6)

Copper port	Multimode optical fiber port	Single mode optical fiber port	Item (3)	Reference (4)	Weight kg/lb
RJ45 shielded connectors	Duplex SC connectors				
8 x 10/100 BASE-TX ports	–	–	–	TCSESM083F23F1	1.000/ 2.205
6 x 10/100 BASE-TX ports	2 x 10/100 BASE-FX ports	–	4	TCSESM063F2CU1	1.000/ 2.205
	–	2 x 10/100 BASE-FX ports	4	TCSESM063F2CS1	1.000/ 2.205

(1) For additional characteristics, see our website www.schneider-electric.com.

(2) Requires Unity Pro Extra Large software ≥ V8.0 (see page 2/19).

(3) For items 5 to 9, see pages 2/18 and 2/19.

(4) Conformal coating version for harsh environments. In this case, add the letter "C" to the end of the reference.

(5) The BMXNOC0402 communication module will be replaced by the BMENOC03•1 modules during the 2nd quarter of 2014.

(6) ConneXium managed switches validated for Modicon M580 architectures.

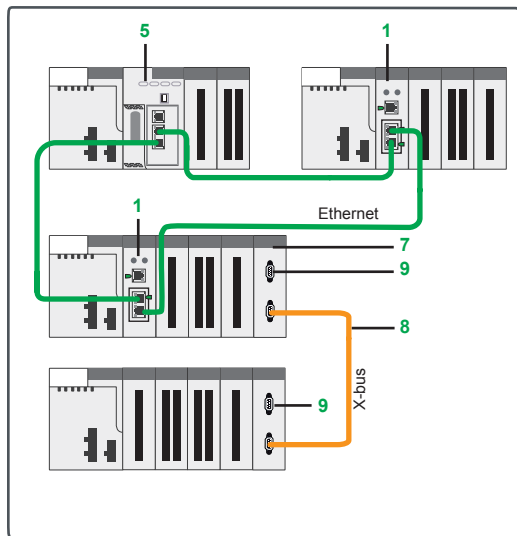

Architecture A + architecture D

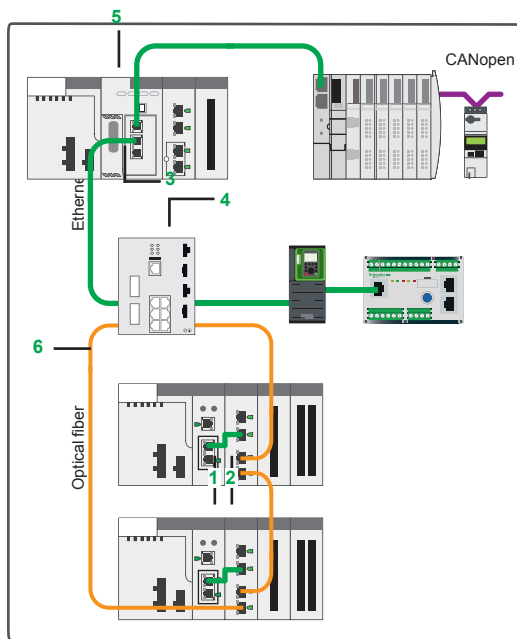

Architecture C + architecture D

References (continued) (1)

Modicon M580 processors

I/O capacity	Maximum number of networks	Device ports	SERVICE port	Item (2)	Reference	Weight kg/lb
1,024 discrete I/O 256 analog I/O 24 application-specific channels 4 MB integrated (memory program)	2 Ethernet networks	2 DIO	1	5	BMEP581020	—
2,048 discrete I/O 512 analog I/O 32 application-specific channels 8 MB integrated (memory program)	2 Ethernet networks	2 DIO	1	5	BMEP582020	—
		2 RIO/DIO	1	5	BMEP582040	—
3,072 discrete I/O 768 analog I/O 64 application-specific channels 12 MB integrated (memory program)	3 Ethernet networks	2 DIO	1	5	BMEP583020	—
		2 RIO/DIO	1	5	BMEP583040	—
4,096 discrete I/O 1,024 analog I/O 64 application-specific channels 16 MB integrated (memory program)	4 Ethernet networks	2 DIO	1	5	BMEP584020	—
		2 RIO/DIO	1	5	BMEP584040	—

Optical fiber cable

Description	Length m/ft	Item (2)	Reference	Weight kg/lb
62.5/125 µm multimode optical fiber cables equipped with MT-RJ connectors	3/9.843	6	490NOR00003	—
For interconnection of the Ethernet port on the CPU or BMECRA adapter 1	5/16.404	6	490NOR00005	—

Rack extension for Modicon X80 drop

Description	Item (2)	Reference	Weight kg/lb
Modicon X80 rack expansion module Standard module for mounting in each rack (XBE slot) and allowing the interconnection of 2 racks max.	7	BMXXBE1000	0.178/ 0.392
Modicon X80 rack expansion kit Complete kit for 2-rack configuration comprising: - 2 BMXXBE1000 rack expansion modules - 1 BMXXBC008K extension cordset, length 0.8 m/2.625 ft - 1 TSXTLYEX line terminator (pack of 2)	7 8 9	BMXXBE2005	0.700/ 1.543

(1) For additional characteristics, see our website www.schneider-electric.com.

(2) For items 1 to 4, see page 2/17.

References (continued) (1)								
Description	Type of connector	Length m/ft	Item (2)	Reference	Weight kg/lb			
X-bus preformed extension cordsets with two 9-pin SUB-D connectors	Elbowed	0.8/2.625	8	BMXXBC008K	0.165/ 0.364			
		1.5/4.921	8	BMXXBC015K	0.250/ 0.551			
		3/9.843	8	BMXXBC030K	0.420/ 0.926			
		5/16.404	8	BMXXBC050K	0.650/ 1.433			
		12/39.370	8	BMXXBC120K	1.440/ 3.175			
	Straight	1/3.281	8	TSXCBY010K	0.160/ 0.353			
		3/9.843	8	TSXCBY030K	0.260/ 0.573			
		5/16.404	8	TSXCBY050K	0.360/ 0.794			
		12/39.370	8	TSXCBY120K	1.260/ 2.778			
		18/59.055	8	TSXCBY180K	1.860/ 4.101			
		28/91.864	8	TSXCBY280KT (3)	2.860/ 6.305			
		Description		Use	Length m/ft	Item (2)	Reference	Weight kg/lb
		Cable on reel Cable with free ends, 2 line testers	To be fitted with 2 TSXCBY9 connectors	100/328.084	–	TSXCBY1000	12,320/ 27.161	
		Description		Use	Sold in lots of	Item (2)	Reference	Weight kg/lb
Line terminator 2 x 9-way SUB-D connectors marked A/ and /B	Required on the 2 BM●XBP●●●●0 modules located at either end of the daisy chain	2	9	TSXTLYEX	0.050/ 0.110			
Bus X straight connectors 2 x 9-way SUB-D connectors	For TSXCBY1000 cable ends	2	–	TSXCBY9	0.080/ 0.176			
Connector installation kit 2 crimping pliers, 1 pen (4)	Fitting TSXCBY9 connectors	–	–	TSXCBYACC10	–			

Requirements for a Modicon M580 Ethernet I/O architecture (1)

The table below gives the minimum hardware and software requirements for setting up a Modicon M580 I/O architecture.

Description of the hardware or software required	Reference	Version	Item (2)
Unity Pro Extra Large software	UNISPUF●CD80	≥ 8.0	–
Modicon X80 RIO drop adapter	BMECRA31210	≥ 2.0	1
	BMXCRA31200	≥ 2.0	1
	BMXCRA31210	≥ 2.0	1
Modicon X80 NRP EIO drop optical repeaters	BMXNRP0200	–	2
	BMXNRP0201	–	2
ConneXium managed switches	TCSESM083F23F1	Firmware ≥ 6.0	4
	TCSESM063F2CU1	Firmware ≥ 6.0	4
	TCSESM063F2CS1	Firmware ≥ 6.0	4
M580 CPUs	BMEP581020	Firmware ≥ 1.0	5
	BMEP582020	Firmware ≥ 1.0	5
	BMEP582040	Firmware ≥ 1.0	5
	BMEP583020	Firmware ≥ 1.0	5
	BMEP583040	Firmware ≥ 1.0	5
	BMEP584020	Firmware ≥ 1.0	5
	BMEP584040	Firmware ≥ 1.0	5

(1) For additional characteristics, see our website www.schneider-electric.com.

(2) For items 1 to 4, see page 2/17; 5 to 7, see page 2/18.

(3) Cable supplied with a set of 2 TSXTVSY100 electrical transient suppressors.

(4) Installation of connectors on the cable also requires a wire stripper, a pair of scissors and a digital ohmmeter.

Type of splitter box and module	Monobloc IP 67 I/O splitter boxes
	Modicon ETB



Available buses and networks	Ethernet Modbus TCP/IP EtherNet/IP
Max. number per connection point	
Discrete I/O	Modularity Splitter box with 16 configurable I/O, 16 I, 12 I + 4 O, or 8 I + 8 O
	Input voltage 24 V $\overline{\text{DC}}$
	Output voltage 24 V $\overline{\text{DC}}$
Analog I/O	–
Application-specific I/O	–
I/O connection	M12 connectors
Type of housing	Plastic
Type of module	ETB1E●●●
Pages	Please consult the catalog pages on our website www.schneider-electric.com

Monobloc IP 20 distributed I/O	Optimum IP 20 distributed I/O	Modular IP 20 distributed I/O
Modicon Momentum	Modicon OTB	Modicon STB



Ethernet Modbus TCP/IP Modbus Plus Fipio INTERBUS Profibus DP DeviceNet	Ethernet Modbus TCP/IP CANopen Modbus (RS 485)	Ethernet Modbus TCP/IP EtherNet/IP CANopen Modbus Plus Fipio INTERBUS Profibus DP DeviceNet
1 I/O base with 1 CPU or 1 communication module	1 interface module + 7 Twido expansion modules	1 NIM (Network Interface Module) + 32 I/O modules
I/O base with 16 I, 32 I, 8 O, 16 O, 32 O, 10 I/8 O, 16 I/8 O, 16 I/12 O and 16 I/16 O	12 I/8 O (interface module) 8 I, 16 I, 32 I, 8 O, 16 O, 32 O, 4 I/4 O and 16 I/8 O (expansion modules)	Module with 2 I, 4 I, 6 I, 16 I, 2 O, 4 O, 6 O or 16 O
24 V $\overline{\text{DC}}$, 120 V \sim and 230 V \sim	24 V $\overline{\text{DC}}$	24 V $\overline{\text{DC}}$, 115 V \sim and 230 V \sim
24 V $\overline{\text{DC}}$ V, 120 V \sim and 230 V \sim and relay	24 V $\overline{\text{DC}}$ and relay	24 V $\overline{\text{DC}}$, 115/230 V \sim and relay
8 I, 16 I or 4 O voltage/current I/O bases I/O base with 4 thermocouple or probe inputs	2 I, 4 I, 8 I, 1 O, 2 O, 2 I/1 O and 4 I/2 O (expansion modules) voltage/current, thermocouple or temperature probe	Modules with 2, 4 or 8 inputs and 1 or 2 outputs (voltage/current) Module with 2 thermocouple or probe inputs
10 kHz/200 kHz 2-channel counter sub-base	Integrated in interface module: - Two 5 kHz/20 kHz channels - 2 PWM function channels	Counter module with one 40 kHz channel HART multiplexer module - 4 HART channels per HART multiplexer module - Up to 8 HART multiplexer modules per island
6 I/3 O 120 V \sim sub-base with 1 Modbus port	–	Parallel interface modules for TeSys Quickfit and TeSys U motor starters, integrated connection for third-party CANopen products
Screw or spring-type removable terminal blocks	Removable screw terminal block (interface module) Removable screw terminal block, non-removable spring-type terminal block and HE 10 connector (expansion modules)	Removable screw or spring-type connectors, Telefast connectors
Plastic		
170A●	OTB1●0DM9LP	STB●●●
Please consult the catalog pages on our website www.schneider-electric.com		

Modicon STB distributed I/O solution

Open and modular system

2



Presentation (1)

To meet the needs of machine manufacturers and users, automation architectures have been decentralized while delivering performance close to that of centralized systems.

Architectures based around islands installed as close to the machine as possible reduce the time and cost of wiring for sensors and actuators, while increasing system availability.

The Modicon STB distributed I/O solution is an open, modular input/output system that makes it possible to design automation islands managed by a master controller via a bus or communication network.

These islands can be used to connect:

- TeSys U or TeSys T starter-controllers
- Altivar variable speed drives
- FTB IP 67 distributed I/O
- OsiSense rotary encoders
- Magelis operator dialog terminals
- Approved third-party products via the CANopen bus: Bosch, Festo, Parker solenoid valves, Balluff linear encoders, etc. (1)

Advantys software guides users through the design phase, start-up, and even maintenance of the system. This single software package covers the Modicon STB, OTB, FTB, and FTM ranges.

The island components are electronic modules mounted on one or more DIN rails. These clusters of modules, known as segments, carry a bus from beginning to end of each island. The island bus provides power distribution, signal sensing, and power management to compatible modules, in the form of a wiring management system.

The Modicon STB I/O family is divided into 2 groups of modules:

- **Basic modules:** A complete set of low-cost modules, with simplified operating modes
- **Standard modules:** An expanded offer of I/O modules, with additional functions: Configurable parameters, expanded operating modes

The basic range comprises:

- PDM power distribution modules (24 V $\overline{\text{---}}$ and 115/230 V \sim)
- I/O modules:
 - Discrete I/O (24 V $\overline{\text{---}}$)
 - Analog I/O (10-bit resolution)

The standard range comprises:

- NIM modules: network interfaces
- PDM power distribution modules (24 V $\overline{\text{---}}$ and 115/230 V \sim)
- I/O modules:
 - Discrete I/O (24 V $\overline{\text{---}}$ and 115/230 V \sim)
 - Analog I/O (10, 12 and 16-bit resolution)
 - Relay outputs (24 V $\overline{\text{---}}$ coil and 24 V $\overline{\text{---}}$ contact or 115/230 V \sim)
- Application module: Counter module, HART multiplexer module
- Dedicated module: For TeSys U and TeSys Quickfit applications
- EOS end of segment and BOS beginning of segment modules
- External equipment support module on CANopen expansion module

Standard and basic modules can be combined on the same island. Combining them in this way allows a wide range of functions (1).

The sensors and actuators are connected to the I/O modules via removable screw or spring-type terminals (2).

Standard Modicon STB I/O modules are hot-swappable, provided the network interface modules are also standard type.

Modicon STB distributed I/O islands have a protection rating of IP 20. For installations in production workshops, they must be housed in enclosures providing at least IP 54 (complying to IEC 60950 or NEMA 250) (1).

Color code	Type of module
Yellow	NIM network interface EOS/BOS island expansion CANopen expansion
Light blue	24 V $\overline{\text{---}}$ discrete inputs
Dark blue	24 V $\overline{\text{---}}$ supply distribution 24 V $\overline{\text{---}}$ discrete outputs
Pink	115 V \sim or 230 V \sim discrete current inputs
Red	115/230 V \sim supply distribution 115/230 V \sim discrete current outputs
Black	Discrete relay outputs TeSys U and TeSys Quickfit interface, counter module
Light green	Analog inputs
Dark green	Analog outputs

(1) For further information, please consult our "Modicon STB IP 20 distributed I/O" catalog available on our website www.schneider-electric.com.

(2) For much easier wiring and to free up space in the electrical cabinet, Modicon STB 16-channel discrete I/O modules can be combined with Modicon Telefast ABE 7 pre-wired or adapter blocks.

Modicon STB distributed I/O solution

Open and modular system

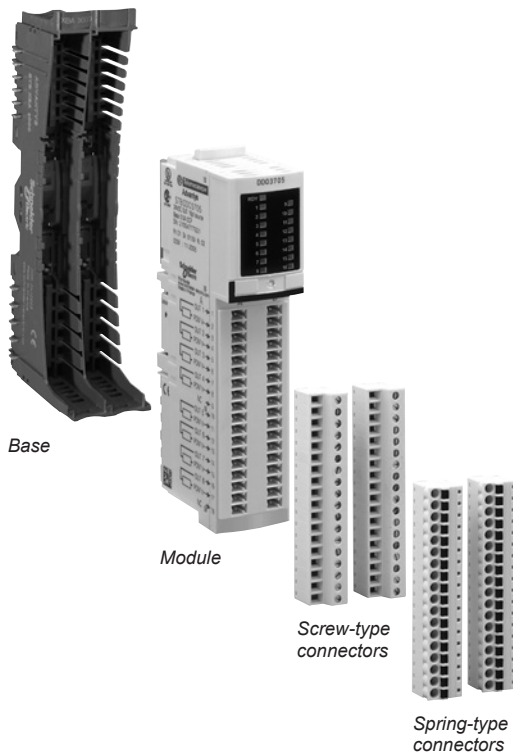

Modicon STB modules (1)

The Modicon STB module references allow you to acquire the following items under a single reference:

- A module
- Its base
- The appropriate screw-type and/or spring-type connectors

The following table gives the contents of the Modicon STB modules and the general form of their references (1).

Module	Contents	Reference (1)
NIM network interface	Module, screw-type and spring-type connectors (base not required), bus terminator, documentation on mini CD-ROM (2) (3)	STBN●●●●●
Power distribution module (PDM)	Base, module, screw-type and spring-type connectors	STB●●●●●K
Discrete I/O (except 16-channel)		
Analog I/O		
EOS and BOS island bus expansion module		
CANopen bus expansion module		
Auxiliary power supply		
TeSys U and TeSys Quickfit interface		
Discrete I/O 16-channel	Base, module, screw-type connectors	STBDD●37●5KS
	Base, module, spring-type connectors	STBDD●37●5KC
	Module (4)	STBDD●37●5
Counting	Base, module, spring-type connectors	STBEHC3020KC

(1) For further information, please consult our "Modicon STB IP 20 distributed I/O" catalog available on our website www.schneider-electric.com.

(2) DeviceNet STBNDN●●●● NIM network interface module: order the 5-way screw and spring-type removable terminals (fieldbus connection) separately (1).

(3) An English language mini-CD-ROM containing the user documentation, a label template and one exchange file per network type. The user documentation is also available on our website www.schneider-electric.com.

(4) For use with the Modicon Telefast ABE 7 pre-wired or adapter system:

- STBXBA3000 base to be ordered separately (1)

- Telefast ABE 7 base and connection accessories to be ordered separately (1)

Modicon STB distributed I/O solution

Open and modular system

Composition of a Modicon STB island (1)

A Modicon STB island is made up of one or more segments comprising PDMs (*Power Distribution Modules*) and I/O modules.

The island begins with a NIM network interface module and ends with a bus terminator supplied with the NIM.

An island can be made up of a single segment or a primary segment and up to 6 expansion segments.

The island's segments are chained by EOS (*End Of Segment*) and BOS (*Beginning Of Segment*) internal bus expansion modules.

On each segment:

- Place the PDMs immediately to the right of the network interface modules or expansion modules.
 - Place the I/O modules to the right of the PDM module supplying them with power.
 - Each module (with the exception of the NIM network interface module), is held in a fixing base on the DIN rail.
- Three module and base widths are possible. On the DIN rail, the overall width needed for a segment is the sum of widths of the network interface module, the bases and any bus terminator.

The bases provide continuity of the internal bus, auto-addressing of the modules, and separated and isolated distribution of the internal power supplies, actuators (outputs) and sensors (inputs).

The advantages of this arrangement are:

- Unplugging modules:
 - When switched off (*cold swap*), modules can be unplugged very quickly
 - When switched on (*hot swap*), I/O modules can be unplugged provided the network interface module is the standard type
- Output power supply independent of inputs: For example, if an output power supply is cut by a Preventa module, the inputs are still managed.
- Immunity of inputs: For example, the closing of power contactors (controlled by outputs) does not disturb analog input measurements.

Network Interface Module (NIM):

This module manages communications on the island bus. It acts as a gateway for exchanges with the fieldbus or network master.

Various NIM network interface modules (only standard type) are available for the following major fieldbuses or industrial networks:

- Ethernet Modbus TCP/IP: Single or double port Network Interface Modules
- EtherNet/IP, Modbus Plus and Fipio: Only standard type NIM network interface modules
- CANopen, INTERBUS, Modbus Plus, Fipio, Profibus DP and DeviceNet

(1) For further information, please consult our "Modicon STB IP 20 distributed I/O" catalog available on our website www.schneider-electric.com.

Modicon STB distributed I/O solution

Open and modular system

Control system configuration example (1)

NIM network interface modules STBN●●2●1●, located at the beginning of each island, are gateways for exchanging data between the network or bus master PLC and the Modicon STB automation island.

Standard NIM network interface modules STBN●●2●1● can be used to configure and address the installation external devices. These settings are stored in the module's internal RAM or Flash memory. Optionally, they can be saved to the 32 KB removable SIM card STBXMP4440 (except for the address of the network connection point) to duplicate the configuration from one island to another.

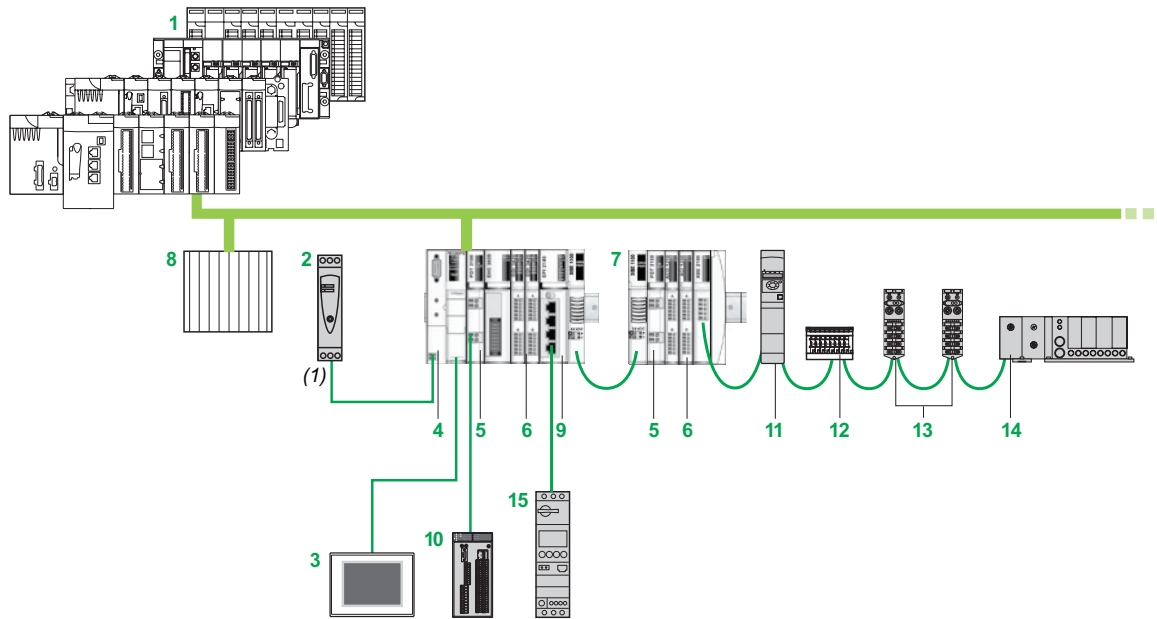

The control system configuration in the above example comprises:

- 1 Modicon M580/M340/Premium/Quantum automation platform
- 2 24 V $\bar{\text{---}}$ external power supply
- 3 HMI terminal with Magelis XBT, XBT G, XBT GT, etc, type Modbus link (1)
- 4 Network Interface Module (NIM)
- 5 Power Distribution Module (PDM)
- 6 I/O modules
- 7 Second STB segment
- 8 Another control system
- 9 Parallel interface module for TeSys U and TeSys Quickfit starter-controllers
- 10 Configurable Preventa XPS MC safety controller connected on the power supply to the outputs of power distribution module STBPDT●100K
- 11 ATV 32 variable speed drive
- 12 Festo solenoid valves
- 13 Modicon FTB IP 67 I/O
- 14 Parker solenoid valves
- 15 TeSys U starter-controller

(1) For further information, please consult our "Modicon STB IP 20 distributed I/O" catalog available on our website www.schneider-electric.com.

Communication selection guide page 3/2

PlantStruxure Ethernet architectures

- **Architecture** page 3/6
 - **Industrial Ethernet communication services** page 3/8
 - Presentation page 3/8
 - Functions page 3/9
 - **Performance** page 3/14
 - **Embedded web pages** page 3/20
 - **Modbus/TCP and EtherNet/IP network module** page 3/24
 - Presentation, functions, description page 3/24
 - References page 3/25
- Web servers and gateways selection guide* page 3/26

Other buses and networks

- **Modbus Plus Proxy module** page 3/28
 - Presentation page 3/28
 - References page 3/29
- **Profibus Remote Master module** page 3/30
 - Presentation page 3/30
 - References page 3/31



Modicon M580 automation platform

Communication, integrated ports and modules

Applications	AS-Interface communication	Serial link communication
Type of device	AS-Interface actuator/sensor bus module	2-channel serial link module



Network protocols		AS-Interface	Modbus and Character mode
Structure	Physical interface	AS-Interface V3 standard	Non-isolated RS 232, 8-wire Isolated RS 485, 2-wire
	Type of connector	3-way SUB-D	2 RJ45 and 1 RJ45
	Access method	Master/slave	
	Data rate	167 Kbps	0.3...115.2 Kbps in RS 232 0.3...57.6 Kbps in RS 485
Medium		Two-wire AS-Interface cable	Shielded twisted pair copper cable
Configuration	Maximum number of devices	62 slaves	2 per drop, 16 per Ethernet remote I/O (RIO) network max.
	Max. length	100 m/328.08 ft, 500 m/1,640.42 ft max. with 2 repeaters	15 m/48.21 ft with non-isolated RS 232, 1,000 m/3,280.83 ft with non-isolated RS 485
	Number of links of the same type per station	All M580 processors: 4 AS-Interface modules	All M580 processors: 36 application-specific channels (1 application-specific channel = 1 counter, motion control module or serial link channel)
Standard services		Transparent exchanges with the sensors/actuators	Read/write bits and words, diagnostics in Modbus mode Send and receive character string in Character mode
Conformity class		M4 profile	–
Embedded Web server service	Standard service	–	–
	Advanced services	–	–
Communication services		–	–
24 V external power supply		–	–
Type of processor or module depending on other integrated port	None	BMXEIA0100	
	Serial link		BMXNOM0200
	Ethernet Modbus/TCP		
	CANopen		
Page		Please consult the "Modicon X80 I/O platform" catalog available on our website www.schneider-electric.com	

Modbus Plus communication	Profibus DP and Profibus PA communication
Modbus Plus proxy module (external)	Profibus Remote Master (PRM) module (external)



Ethernet Modbus/TCP	Modbus Plus	Ethernet Modbus/TCP	Profibus DP V1 Profibus PA (via gateway)
10/100BASE-T	Modbus Plus standard	10BASE-T/100BASE-TX	Isolated RS 485
Two RJ45 connectors	Two 9-way female SUB-D connectors	Two RJ45 connectors (supporting daisy chain topology)	One 9-way female SUB-D connector
CSMA-CD	Token ring	CSMA-CD	Master/slave
10/100 Mbps	1 Mbps	10/100 Mbps	9.6 Kbps...12 Mbps
Double shielded twisted pair copper cable, category CAT 5E (direct or crossover)	Twisted pair copper cable	Double shielded twisted pair copper cable, category CAT 5E (direct or crossover)	Shielded twisted pair copper cable
128	32 per segment 64 for all segments	Several PRMs can be connected to the Ethernet port on the M580, M340, Premium or Quantum PLC, as long as the I/O Scanner capacity is not exceeded	125 slaves
100 m/328.08 ft	450 m/1,476.37 ft per segment 1,800 m/5,905.49 ft with 3 repeaters	100 m/328.08 ft (copper)	1,200 m/3,936.99 ft (9.6 Kbps), 4,800 m/15,747 ft with 3 repeaters, 100 m/328.08 ft (12 Mbps), 400 m/1,312.33 ft with 3 repeaters
1 max.	–	–	–
–	–	–	–
Modbus/TCP messaging	Modbus Plus messaging	Modbus/TCP messaging	Cyclic and acyclic data exchange with slaves
–	–	Transparent Ready Class A20	Class 1 and Class 2
–	–	–	–
Configuration, diagnostics	–	–	–
–	–	–	–
Modbus Plus server (scanned by the PLC)	Reading/writing variables	Modbus server (scanned by the PLC)	Master/slave communication
FDR service	Global database	FDR service	Global Control service
SNMP agent network management service	Peer Cop service	SNMP agent network management service	Acyclic communication (read/write) in Class 1 and Class 2
–	–	–	Support for extended diagnostics
–	–	–	Auto-scanning service of slaves on the bus
19.2...31.2 V	–	18...30 V	–
TCSEGDB23F24FA		TCSEGA23F14F	
3/29		3/31	

Modicon M580 automation platform

PlantStruxure Ethernet architectures
Logical communication architecture

Logical communication architecture

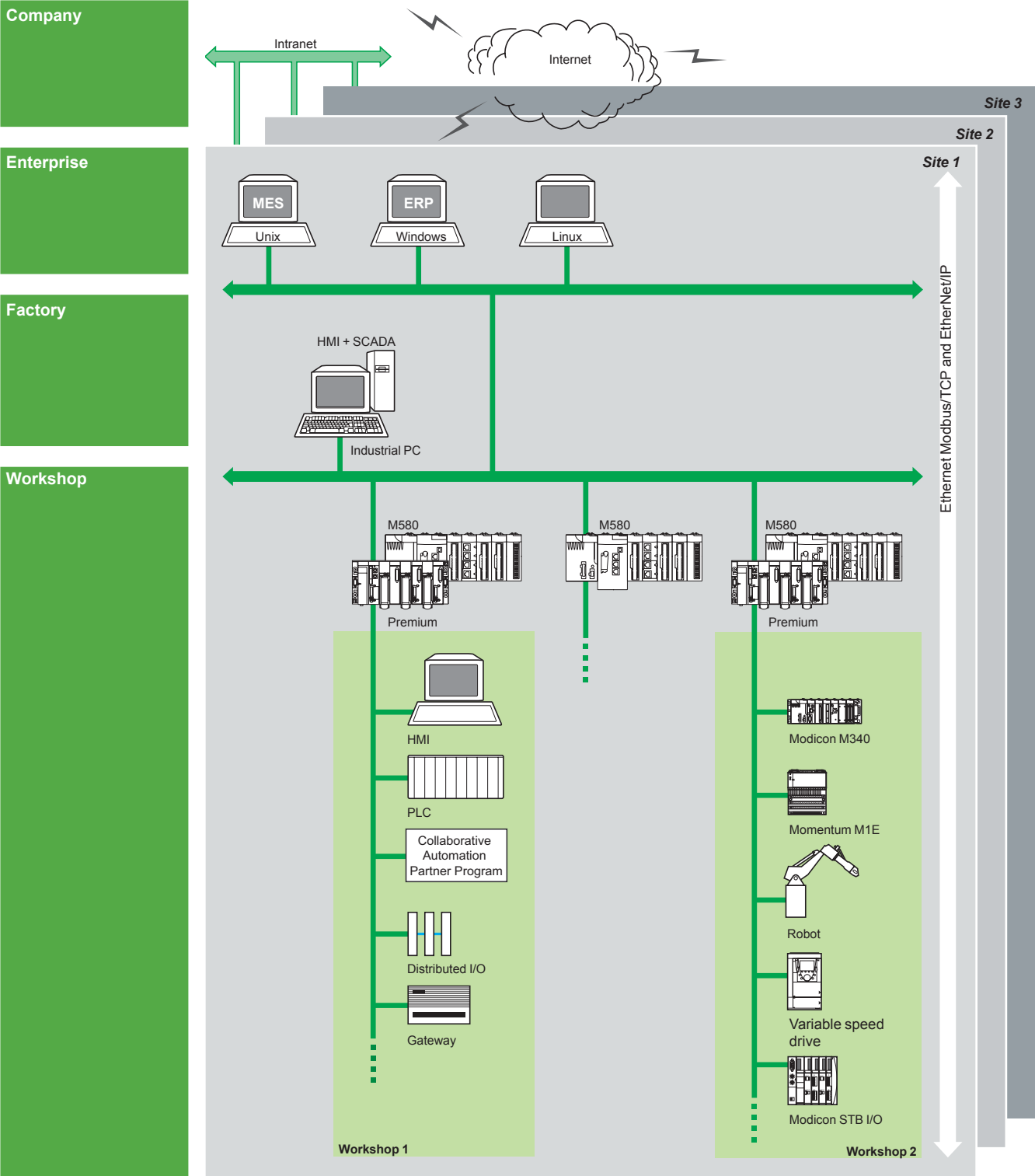

MES: Manufacturing Execution System (production management system)
ERP: Enterprise Resource Planning (integrated management software packages)
IHM/SCADA: Human/Machine Interface and Supervision Control And Data Acquisition
Gateway: Gateway to sensor/actuator bus, to installed base network, fieldbus, etc.

Physical communication architecture

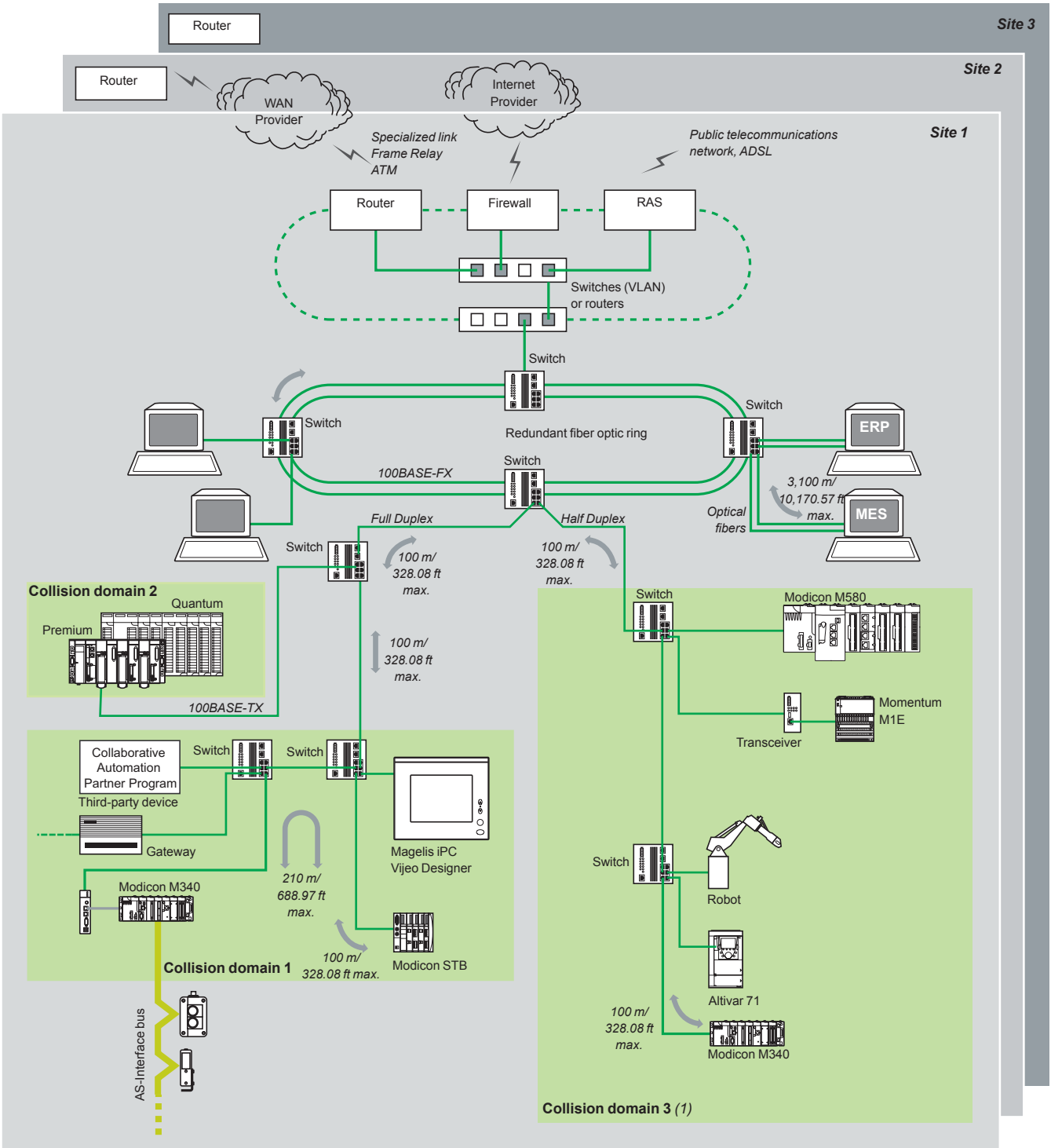

(1) As a general rule, defining several collision domains can increase the size of the architecture and improve performance (see pages 8/2 to 8/7).

Modicon M580 automation platform

PlantStruxure Ethernet architectures
Industrial Ethernet communication services

Presentation

PlantStruxure Ethernet architectures provide transparent communication services to the entire operation through the implementation of standard, unmodified Ethernet protocols and services.

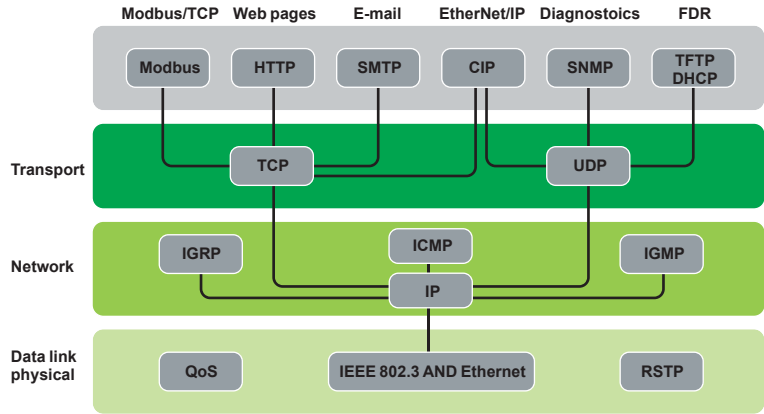

- In addition to the typical Ethernet services (HTTP, BOOTP, DHCP, etc.) Ethernet communication modules are equipped with automation-specific services, such as:
- Device scanning using Modbus TCP and EtherNet/IP
 - Messaging using Modbus TCP and EtherNet/IP
 - Automatic replacement device configuration using FDR (Fast Device replacement)
 - Extensive diagnostics through SNMP
 - Clock synchronization using NTP
 - E-mail alarm notification via SMTP
 - Packet prioritization using QoS
 - Ring topology redundancy through RSTP

Note: The above services may not be offered in all devices. Please refer to the Selection Guide and Reference pages for a comprehensive list of the services offered by each device.

3

Functions

Ethernet basic services

HTTP (RFC 1945)

HTTP (HyperText Transfer Protocol) is used to transmit Web pages between a server and a browser. HTTP has been used on the Web since 1990. Web servers embedded in Schneider Electric automation products provide easy access to information and diagnostics from anywhere in the network.

BOOTP/DHCP (RFC1531)

BOOTP/DHCP is used to provide devices with IP parameters automatically. This avoids having to manage each device address individually by transferring this management to a dedicated IP address server.

The DHCP protocol (*Dynamic Host Configuration Protocol*) is used to assign configuration parameters to devices automatically. DHCP is an extension of BOOTP.

Schneider Electric devices can be:

- BOOTP clients, allowing the IP address to be retrieved automatically from a server, or
- BOOTP servers, allowing the device to distribute IP addresses to the network stations.

FTP (File Transfer Protocol) & TFTP (Trivial File Transfer Protocol) (RFCs 959, 2228, and 2640)

File Transfer Protocols such as FTP and TFTP provide the basic elements for file sharing. In an automation device, FTP or TFTP are often used to deliver firmware updates.

NTP (Network Time Protocol) (RFC 1305)

NTP (*Network Time Protocol*) is used to synchronize the time of a client device from a time server.

SMTP (Simple Mail Transfer Protocol) (RFC 0821)

SMTP (Simple Mail Transfer Protocol) is an e-mail transmission service. It is used to send e-mail between a sender and a recipient via an SMTP email server.

SNMP (Simple Network Management Protocol) (RFCs 1155, 1156, and 1157)

Simple Network Management Protocol (SNMP) is an Internet protocol used to manage IP based network devices. SNMP is used to:

Monitor network components, such as computer workstations, routers, switches, bridges, and end devices to view their status.

Obtain statistics about the network, such as bandwidth utilization and detected errors on the network.

Change information in the device SNMP database, such as when to report a high temperature condition.

SNMP is comprised of a network manager (usually running on a computer) and agents (running on the network devices). Network Management Systems (NMS) are software applications used to manage SNMP managed devices.

QoS (Quality of Service) (RFC 2474)

QoS provides the ability to mark, or "tag", packets of a specific type or origin so that in a congested network, the switches will give higher priority to the most important packets.

RSTP (Rapid Spanning Tree Protocol)

RSTP has been implemented in Schneider Electric automation products to allow multi-port devices to be connected in ring configurations. It helps prevent the formation of broadcast storms and monitors the state of the ring.

Should a link in the ring become disconnected, the protocol routes packets in a different direction to help ensure continuity of service.

Schneider Electric offers a Network Management software application tailored for the industrial control environment. ConneXium Network Manager has been developed with Automation and Controls professionals in mind. ConneXium Network Manager provides a window in network equipment operation to help improve plant productivity. The software can be used to:

- Discover network devices and generate a network map
- Set network performance thresholds and alerts for detected errors to help avoid downtime
- Manage ports (multiple ports at once)
- Baseline network performance
- Document the network
- Generate a report to send to technical support
- Interface to SCADA via the built-in OPC server

The software is compatible with third-party as well as Schneider Electric network devices.

Modbus/TCP function codes		dec	hex
Bit access	Read n input bits	02	02
	Read n output bits	01	01
	Read exception status	07	07
	Write 1 output bit	05	05
	Write n output bits	15	0F
	Read 1 input word	04	04
	Read n input words	03	03
	Write 1 output word	06	06
	Write n output words	16	10
	Read device ID	43/14	2B/0E

Examples of Modbus/TCP function codes for accessing data and diagnostics

Functions (continued)

Modbus standard communication protocol

Modbus, the industry communication standard since 1979, has been combined with Ethernet Modbus/TCP, the medium for the Internet revolution, to form Modbus/TCP, a completely open Ethernet protocol. The development of a connection to Modbus/TCP does not require any proprietary component, nor purchase of a license. This protocol can easily be combined with any product supporting a standard TCP/IP communication stack. The specifications can be obtained free of charge from the following website: www.modbus.org.

Modbus/TCP, simple and open

The Modbus application layer is very simple and universally familiar with its 9 million installed connections. Thousands of manufacturers have already implemented this protocol. Many have already developed a Modbus/TCP connection and numerous products are presently available. The simplicity of Modbus/TCP enables any field device, such as an I/O module, to communicate on Ethernet without the need for a powerful microprocessor or a lot of internal memory.

Modbus/TCP, high-performance

Due to the simplicity of its protocol and the fast speed of 100 Mbps Ethernet, Modbus/TCP performance is excellent. This allows this type of network to be used in real-time applications such as I/O scanning.

Modbus/TCP, a standard

The application protocol is identical on Modbus serial link, Modbus Plus, or Modbus/TCP. This means that messages can be routed from one network to the other without converting protocol. Since Modbus is implemented on top of the TCP/IP layer, users can also benefit from IP routing, enabling devices located anywhere in the world to communicate without worrying about the distance between them. Schneider Electric offers a complete range of gateways for interconnecting a Modbus/TCP network to existing Modbus Plus or Modbus serial link networks.

The IANA organization (Internet Assigned Numbers Authority) has allocated the fixed, well-known port 502 to the Modbus protocol. Thus Modbus has become an Internet standard.

Modbus and Modbus/TCP are recognized by the IEC/EN 61158 international standard as a fieldbus. They are also compliant with the “Chinese National Standard” managed by ITEI.

Interfacing CANopen with Modbus/TCP

CiA DSP 309-2 provides standardized mapping of CANopen data for transport on Ethernet Modbus/TCP networks. The specification reserves Modbus function code 43/13 for this purpose. This function code is reserved exclusively for CANopen.

Modbus TCP/IP characteristics

- Maximum size of data:
- Read: 125 words or registers
 - Write: 100 words or registers

Functions (continued)

EtherNet/IP standard communication protocol

EtherNet/IP is an industrial communications protocol based on the Common Industrial Protocol (CIP) which is owned and managed by the ODVA, an international, independent standards organization (www.odva.org).

Standard, unmodified Ethernet

Schneider Electric added EtherNet/IP as a core network in 2007. EtherNet/IP is very similar to Modbus TCP in many aspects. In particular, it shares the same principles of standardization and interoperability. EtherNet/IP operates on the same equipment and infrastructure as Modbus TCP, and both protocols can operate simultaneously on the network at any time.

Advanced services and high performance

EtherNet/IP is built on an object-based model. Data in each EtherNet/IP device is grouped in objects, and each device may have different types of object, depending on the purpose of the device.

EtherNet/IP objects

The Ethernet modules implement the standard set of objects prescribed by the ODVA. The most common objects are listed below:

Communication	Identity Object (01hex)
	Message Router Object (02hex)
	Assembly Object (04hex)
	Connection Object (05hex)
	Connection Configuration Object (F3hex)
	Connection Manager Object (06hex)
EtherNet/IP Network	Modbus Object (44hex)
	QoS Object (48hex)
	Port Object (F4hex)
	TCP/IP Interface Object (F5hex)
Diagnostics	Ethernet Link Object (F6hex)
	EtherNet/IP Interface Diagnostic Object (350hex)
	EtherNet/IP IO Scanner Diagnostic Object (351hex)
	IO Connection Diagnostic Object (352hex)
	EtherNet/IP Explicit Connection Diagnostic Object (353hex)



Functions (continued)

I/O Scanning service

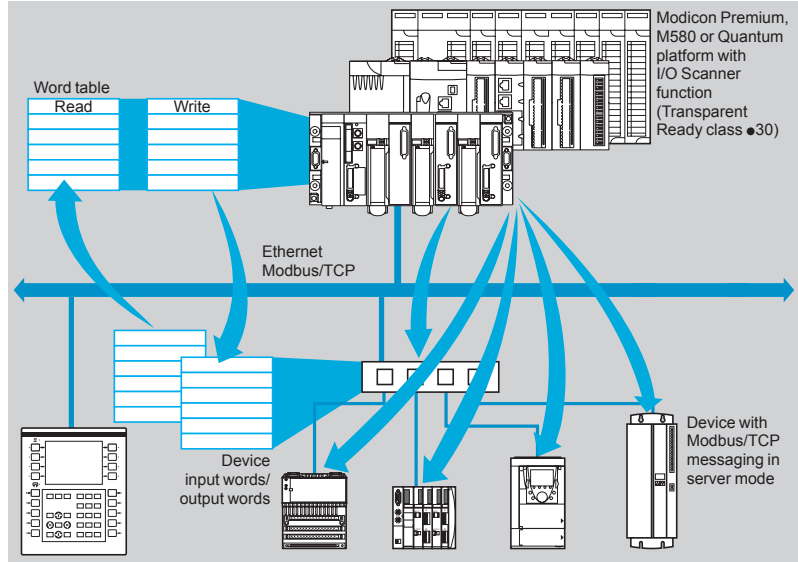

The I/O Scanning Service is used to manage the exchange of remote I/O states on the Ethernet network after simple configuration, without the need for any special programming.

I/O scanning is performed transparently by means of read/write requests according to the Modbus client/server protocol on the TCP/IP profile.

This principle of scanning via a standard protocol enables communication with any device supporting Modbus TCP messaging in server mode.

This service can be used to define:

- A %MW word zone reserved for reading inputs
- A %MW word zone reserved for writing outputs
- Refresh periods independent of the PLC scan

During operation, the module:

- Manages TCP/IP connections with each remote device
- Scans devices and copies the I/O to the configured %MW word zone
- Feeds back status words used to check that the service is working correctly from the PLC application.
- Applies pre-configured fallback values if a communication error is detected

A range of hardware and software products is available enabling the I/O Scanning protocol to be implemented on any type of device that can be connected to the Ethernet network.

Characteristics

- Under Unity Pro software, each station can exchange a maximum of:
 - 120 write words
 - 125 read words
- Maximum size in the PLC managing the service:
 - 1 Kword %MW in inputs and 1 Kword %MW in outputs with manager PLC limited to 64 stations
 - 2 or 4 Kwords %MW in inputs and 2 or 4 Kwords %MW in outputs with manager PLC limited to 128 stations

I/O Scanning service diagnostics

I/O Scanning service diagnostics can be performed in one of five ways:

- Via the application program from a specific PLC data zone
- From the setup software debug screen
- From the PLC system diagnostic function displayed by means of an Internet browser on a PC station
- Using standard SNMP network management software

Functions (continued)

FDR (Fast Device Replacement) service

The Fast Device Replacement service uses standard address management technologies (BOOTP, DHCP) and the TFTP (Trivial File Transfer Protocol) file management service, with the aim of simplifying maintenance of Ethernet devices.

It is used to replace a device with a new device that will be detected, reconfigured, and automatically restarted by the system.

The main steps in replacement are:

- 1 The device to be replaced is identified.
- 2 Another similar device is taken from the maintenance store, preconfigured with the Device name for the existing device, then reinstalled on the network. Depending on the device, addressing can be performed using rotary selector switches (as for Modicon STB distributed I/O or Modicon OTB for example) or can be given using the keypad integrated in the device (as for Altivar variable speed drives for example).
- 3 The FDR server detects the new device, allocates it an IP address, and transfers the configuration parameters to it.
- 4 The replacement device checks that all these parameters are indeed compatible with its own characteristics and switches to operational mode.

The FDR server can be:

- A Modicon M340 Ethernet network module, **BMXNOC0401**
- A Modicon M580 Ethernet network module, **BMXNOC0402** (1)
- A Modicon Premium Ethernet module, **TSXETC101**
- A Modicon Quantum PLC Ethernet module, **140NOC77101**, **140NOC78000**, **140NOC78100**
- A Modicon Premium CPU with integrated Ethernet port, **TSXP57●●●●M**
- A Modicon Quantum CPU with integrated Ethernet port, **140CPU65150/60**, **140CPU65260**

(1) The **BMXNOC0402** communication module will be replaced by the **BMENOC03●1** modules during the 2nd quarter of 2014.



FDR client device example

Selecting the communication architecture

When selecting an architecture, performance needs to be taken into account at the earliest possible stage. To do this, developers need to:

1 Determine the precise requirements:

- quantity and type of devices to be interconnected
- volume and type of exchanges
- expected response times
- environment

2 Compare the requirements with the characteristics of the offers available and be aware that the actual performance level between any 2 points in an architecture depends on the weakest link in the chain, which can be:

- dependent on the hardware
- but also dependent on the applications (size, architecture, operating system, machine power rating, etc.), which are often only vaguely defined at this stage of the project

3 Decide which is the most suitable architecture

The purpose of the next few pages is to provide the main information and instructions needed to answer the second point. Given that the performance of an Ethernet architecture is linked to several parameters, these pages do not supply all the information needed to calculate the network performance. Their aim is to focus on the following main aspects:

■ **Guidelines for calculating the network load** so as to design an Ethernet network that meets the application requirements

■ **Application response time** to be obtained depending on the configuration used (see pages 3/15 to 3/17)

■ **Processing capability of Modicon M340, Modicon M580, Modicon Premium, and Modicon Quantum** platforms so as to be able to select the CPU and define the number of Ethernet connections required on the PLC depending on the application (see pages 3/18 and 3/19)

Calculating the network load

Introduction

When calculating the load on an Ethernet network, all the communication services of all the peripheral devices connected to the network need to be calculated.

Because of the outstanding performance of the Ethernet network, the load is often less than the Ethernet network limits and does not significantly affect the application response time. This phenomenon is explained by the high speed of the Ethernet network: the network transaction time is 10% less than the application response time. In order to keep the network load low and avoid large theoretical calculations, it is highly advisable to separate the collision domain so as to limit the network load, using only the switched network (tree, star, or daisy-chain topology).

Modicon M580 automation platform

Ethernet Modbus/TCP network Performance

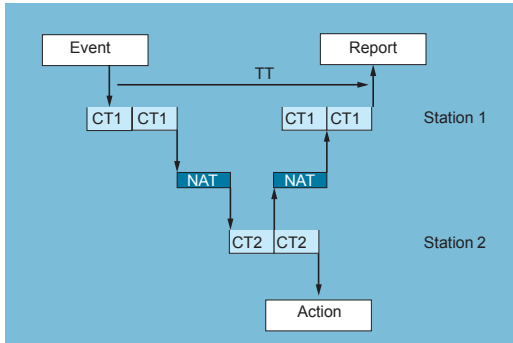

Modbus messaging service response time

Application response time

Modbus (or Uni-TE) messaging service response time

Exchanges between the PLC CPU and the Ethernet module are synchronous with the PLC scan cycle time (CT), just like the I/O exchanges. When an event occurs (such as an input being set to 1 for example), a message can be transmitted only after this input has been taken into account (start of the next cycle) and the PLC (Modicon M340, Modicon Premium, or Modicon Quantum) program has been executed, i.e. on average approximately 1.5 cycles after the event occurred.

The network access time (NAT) shown in the table below in ms is a total of the module transit time and the delay before the message can be transmitted on the network.

Processing Modbus TCP/IP message requests	Modicon M580 BMEP58		Modicon M580 BMX	Modicon M340 BMX		Modicon Premium TSX		Modicon Quantum 140	
		1020 2020	2040 3020 3040 4020 4040	NOC0402 (1)	NOC0401	P342020 P342030	ETY210 ETY110WS	ETC101 WMY100 P5710...57 60	NOC77101/78●●● CPU113/311●● CPU434/5341●
Network access time (NAT)	< 10 ms	< 10 ms	< 10 ms	< 10 ms	< 10 ms	< 25 ms	< 10 ms	< 10 ms	< 10 ms

The transaction time TT includes the delay between the transmission of a message from a client (station 1), its reception by the server (station 2), processing the request, sending back the response, and it being taken into account by the station 1 (updating an output for example).

As the block diagram above shows:

- The transaction time TT will be between:

$$2 \times CT1 + 2 \times NAT < TT < 4 \times CT1 + CT2 + 2 \times NAT$$
- The average duration TT_{av} is equivalent to:

$$TT_{av} = 3 \times CT1 + 0.5 \times CT2 + 2 \times NAT$$

(1) The **BMXNOC0402** communication module will be replaced by the **BMENOC03●1** modules during the 2nd quarter of 2014.



Modicon M580 automation platform

Ethernet Modbus/TCP network Performance

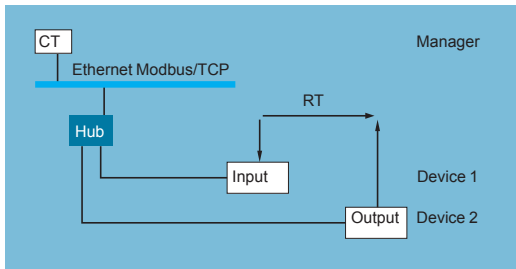

I/O Scanning service response time

Application response time (continued)

I/O Scanning service response time

The response time RT includes the time between taking account of information from a remote input and updating the state of a remote output. It includes the processing time in the PLC.

This response time RT consists of the following parameters:

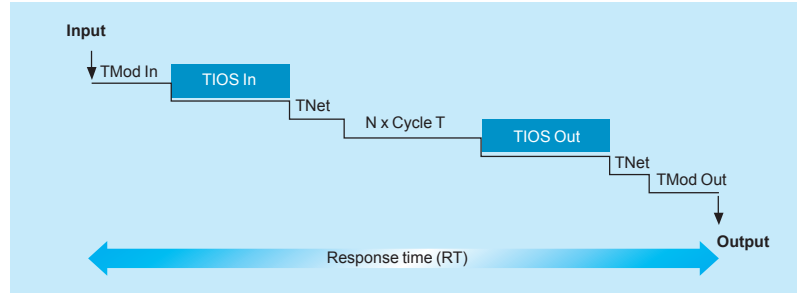

- TMod In and TMod Out: Response time of the read/written device, excluding the electrical transition time at the input/output (TMod depends on the device, usually between 1 and 8 ms)
- TIOS In and TIOS Out: Time between 2 read/write operations on the same device (0.3 ms x number of devices scanned), at least equivalent to the configured scan time
- As TIOS is executed in parallel with the PLC cycle, it can be hidden from the viewpoint of the response time RT.
- Cycle T: PLC scan cycle time
- TNet: Propagation time on the network (depends on the application, but usually TNet = 0.05 ms at 10 Mbps and 0.005 ms at 100 Mbps)

The response time RT can be estimated using the following 3 formulae:

■ RT_{min} : minimum response time with TIOS hidden and 1 PLC scan cycle:

$$RT_{min} = (TMod In + 0) \times TIOS In + (Tnet + N) \times cycle T + (0 \times TIOS Out) + Tnet + TMod Out$$

■ RT_{typic} : typical response time with 0.5 TIOS hidden:

$$RT_{typic} = (TMod In + 0.5) \times TIOS In + (Tnet + N) \times cycle T + (0.5 \times TIOS Out) + Tnet + TMod Out$$

■ RT_{max} : maximum response time with TIOS not hidden:

$$RT_{max} = TMod In + TIOS In + (Tnet + N) \times T cycle + TIOS Out + Tnet + TMod Out$$

Modicon M580 automation platform

Ethernet Modbus/TCP network Performance

Application response time (continued)

I/O Scanning service response time (continued)

Below are the TMod In and TMod Out response times:

Type of distributed I/O	Response time	Min.	Typical	Max.
Momentum 170ENT11002	TMod In	1 ms	1 ms	1 ms
	TMod Out	5 ms	5 ms	5 ms
Momentum 170ENT11001	TMod In	4 ms	6 ms	8 ms
	TMod Out	4 ms	6 ms	8 ms
Advantys STB STBNIP2212	TMod In	2 ms	3 ms	4 ms
	TMod Out	2 ms	3 ms	4 ms

The TIOS In/TIOS Out times measured between 2 scan cycles (Ethernet network with switches) are shown below:

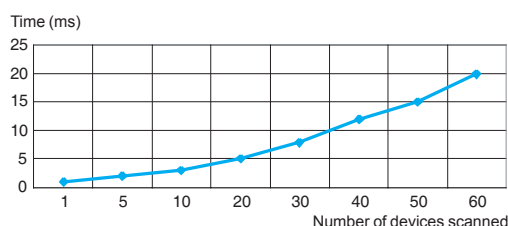

The number N of CPU scan cycles is shown below:

	Number of CPU cycles N	Min.	Typical	Max.
Modicon M340 platform with BMXNOC0401 module		2	2.5	3
Modicon M580 platform with BMXNOC0402 module (1)				
Premium platform with TSXETY4103 and TSXETY5103 modules				
Quantum platform with 140NOE77101 and 140NOE77111 modules				
Quantum platform with 140NOC77101 and 140NOC78000 modules				
Modicon M580 platform with BMEP580000 modules				
Modicon M340 BMXP342020/2030 CPUs				
Premium TSXP5726/3634M , TSXP5726/2823M and TSXP5736/4823AM CPUs	1	1	2	
Premium TSXP5746/56/6634M CPUs				
Quantum 140CPU65150/60 CPUs				

(1) The **BMXNOC0402** communication module will be replaced by the **BMENOC0301** modules during the 2nd quarter of 2014.



Modicon M580 automation platform

Ethernet Modbus/TCP network Performance

Processing capacities of Modicon platforms

Processing capacity

Use the table below to compare, for each station, the total number of messages received via the Modbus (or Uni-TE) messaging service if used (value R1, R2, or Ri) with the capacity of the station CPU.

Processing of Modbus requests per PLC scan cycle:

Modicon M340, Modicon Premium/Atrium platforms	Messages received
Total messages received by the PLC from all the communication modules (1)	
TSX5710	4 messages/cycle
BMXP3420/TSX5720	8 messages/cycle
TSX5730	12 messages/cycle
TSX5740	16 messages/cycle
TSX5750/60 (2)	16/20 messages/cycle

Modicon Quantum platform	Integrated port limitations		Communication module limitations		Ethernet modules per PLC
	All types of communication request	Additional read/write 4x registers	All types of communication request	Additional read/write 4x registers	
140CPU113 (3)	–	–	1 message/cycle	4 messages/cycle	Up to 2
140CPU311	–	–	1 message/cycle	4 messages/cycle	Up to 2
140CPU434/534	–	–	4 messages/cycle	8 messages/cycle	Up to 6
140CPU651	16 messages/cycle	16 messages/cycle	4 messages/cycle	8 messages/cycle	Up to 6

Messages/cycle: number of messages received per cycle from the PLC master task (typical cycle of 50 to 100 ms)

Example:

Quantum 140CPU43412 CPU with 4 Ethernet 140NOE7711 modules:

- 20 messages/cycle for all types of communication request, and
- 32 messages/cycle for the read/write 4x registers

Ethernet transaction processing capacity

For each station, compare the total number of messages received Σ [values Ri, Rj] and the total number of messages transmitted Σ [values Ei, Ej] (for station N, for example) with the Ethernet transaction processing capacity shown below.

Use the elements below for the Ethernet connection per PLC, rather than the number of transactions required by the application.

Ethernet transaction processing capacity	Modicon M340 BMX		Modicon Premium TSX			Modicon Quantum 140	
	NOC0401	P342020 P342030	ETY210 ETY110WS	ETC101 WMY100 P5710/20/30/40	P5750 P5760	NOC77101 /78... NWM10000	CPU65... CPU67... CPU68...
Modbus messaging	500 transactions/s	500 transactions/s	60 transactions/s	450 transactions/s	500 transactions/s	350 transactions/s	350 transactions/s
I/O Scanning service	2000 transactions/s	Server mode (5)	Service not available	2000 transactions/s (6)	2000 transactions/s	2000 transactions/s (6)	2000 transactions/s
Global Data subscription	800	Service not available	Service not available	800 (6)	800	800 (6)	800

(1) A temporary overload, due for example to an adjustment terminal or the temporary connection of an Internet browser, lasting for a few PLC scans, is permitted.

(2) Only with Unity Pro software.

(3) Only with Concept/ProWORX software.

(4) The BMXNOC0402 communication module will be replaced by the BMENOC031 modules during the 2nd quarter of 2014.

(5) BMXP34200 CPUs with Modbus TCP messaging in server mode can be scanned by a device with the I/O Scanning service.

(6) TSXWMY100 and 140NWM10000 modules do not have I/O Scanning and Global Data services.

Modicon M580 automation platform

Ethernet Modbus/TCP network Performance

Processing capacities of Modicon platforms (continued)

Number of simultaneous TCP/IP connections

The number of simultaneous TCP/IP connections depends on the platform as well as the type of connection to the Ethernet network:

- 10/100BASE-TX port in network modules
- 10/100BASE-TX port integrated in CPUs

Number of simultaneous TCP/IP connections	Modicon M340 BMX		Modicon Premium TSX		Modicon Quantum 140		
	NOC0401 NOE0110	P342020 P342030	ETY210 ETY110WS	ETC101 WMY100 P5710...5760	NOC77101/78●●● CPU113/311●● CPU434/53414B	CPU65●●● CPU67●●●	NOC77101 NOC78●00
Client	16	16	32	16 (1)	16 (1)	16 (1)	16
Server	32	32		64 (1)	64 (1)	64 (1)	32

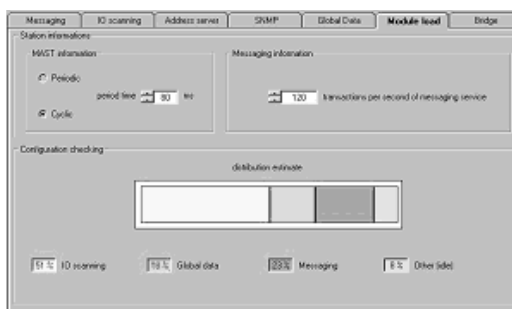

Bandwidth management

Bandwidth management for Ethernet Modbus/TCP modules

The bandwidth management service indicates the load level of the Ethernet network module. This allows the user to monitor resource consumption and help ensure a good module performance.

The Ethernet module load is indicated in one of three ways:

- Expected load in the Unity Pro configuration screen
- Actual load in the Unity Pro diagnostics/debug screen
- In the SNMP interface for access by the SNMP network manager

The bandwidth is shown as a percentage for each of the following services:

- Modbus (and Uni-TE) messaging
- I/O Scanning
- Others



Ethernet port integrated in the CPU (for example with BMEP584040 Modicon M580 CPU)

or



Dedicated Ethernet module (for example with BMXNOC0402 Modicon M580 module) (2)

Ethernet solutions with Modicon M580 platforms

Modicon M580 platforms feature two types of connection to the Ethernet network:

- The 10/100BASE-TX port integrated in the CPUs, which also process the application and exchange data with the other modules supported by the rack and other communication ports (CANopen bus, Modbus serial link, etc.)
- The multiple 10/100BASE-TX port in dedicated Ethernet modules on which, unlike the CPU with integrated Ethernet port, all the resources are allocated to Ethernet Modbus/TCP and EtherNet/IP communication

These fundamentally different hardware characteristics result in equally different capacities in terms of services and performance:

- The integrated port is a low-cost way of satisfying applications that are not too demanding in terms of communication (≤ 500 user messages/s).
- Where there are a large number of exchanges, use of a dedicated Ethernet network module is strongly recommended to help improve performance.

(1) With 64 TCP/IP connections maximum (cumulative total of client and server connections).

(2) The **BMXNOC0402** communication module will be replaced by the **BMENOC03●1** modules during the 2nd quarter of 2014.

Modicon M580 automation platform

Embedded web pages

3

The M580 CPU includes a Hypertext Transfer Protocol (HTTP) server. The server transmits web pages for the purpose of monitoring, diagnosing, and controlling remote access to the communication module. The server provides easy access to the CPU from standard internet browsers.

The embedded web server pages are used to display real-time diagnostic data for the M580 CPU.

Requirements

The embedded web server in M580 CPUs displays data in standard HTML web pages. The embedded web pages can be accessed on a PC, iPad®, or Android® tablet with the following browsers:

- Internet Explorer® (V8 or later)
- Google Chrome® (V11 or later)
- Mozilla Firefox® (V4 or later)
- Safari® (V5.1.7 or later)

Diagnostic web pages

The M580 CPU Diagnostic web pages provide information on Status Summary, Performance, Port Statistics, I/O Scanner, Messaging, QoS (quality of service), Network Time Service, Redundancy and Alarm Viewer. All these pages are updated every 5 seconds to get the latest information.

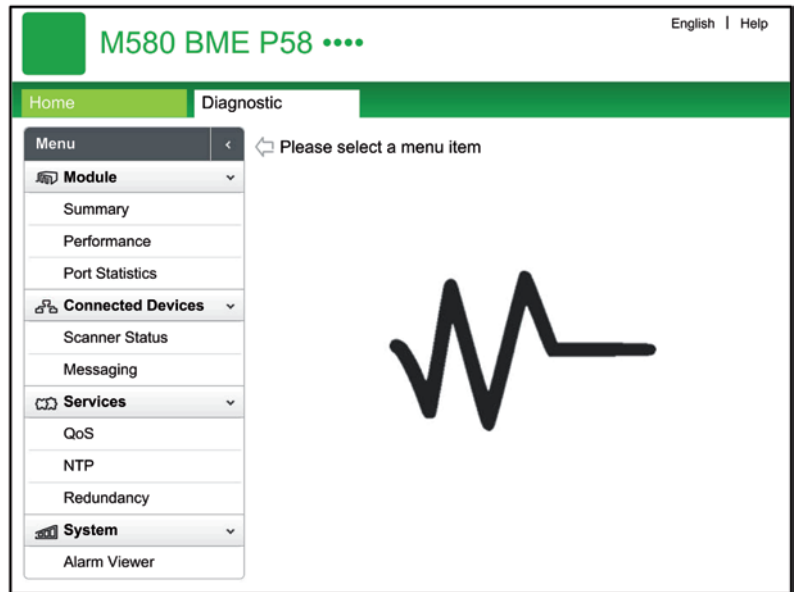

Status Summary

■ RUN	■ ERR	■ I/O	■ CARD_ERR
MOD STATUS		CARD_ACT	
■ NETWORK STATUS			

Service Status		Version Info.	
● DHCP Server	Unknown	Exec. Version	0.4
● FDR Server	Unknown	Kernel Version	0.0
● Access Control	Unknown	Web Server Version	1.0
● Scanner Status	Unknown	Web Site Version	1.1.0.0
● NTP Status	Unknown	CIP Version	1.0

CPU Summary		Network Info.	
Model	M580 CPU	IP Address	192.168.10.1
State	RUN	Subnet Address	255.255.0.0
Scan Time	2ms	Gateway Address	0.0.0.0
Logged In	No	MAC Address	00 11 00 13 80 10
CPU Exec. Version	4.01	Host Name	FAILED
Unity Program	NO PROG		

Status summary

Status Summary page

The objects on this page provide status information.

Parameters	Description
LEDs	The black field contains LED indicators (RUN, ERR, etc.)
Service Status	Green The available service is operational and running Red An error is detected in an available service Black The available service is not present or not configured
Version Info.	This field describes the software versions that are running on the CPU
CPU Summary	This field describes the CPU hardware and the applications that are running on the CPU
Network Info.	This field contains network and hardware address information and connectivity that corresponds to the CPU

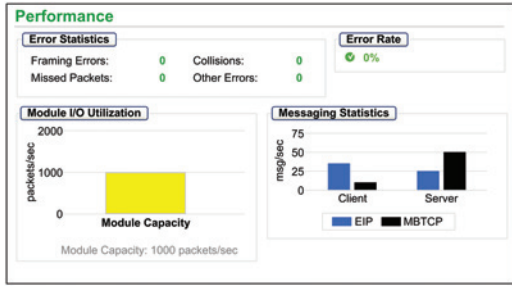

Performance

Diagnostic web pages (continued)

Performance page

The objects on this page provide information on performance statistics.

Field	Description
Error Statistics	This area contains the detected errors in the diagnostics data for the CPU (these counters can be reset to 0 with the Reset Counters button)
Error Rate	This percentage represents the total number of packets divided by the number of packets that are not associated with detected errors
Total Bandwidth Utilization	This value indicates the percentage of the available bandwidth that the CPU is using
Module I/O Utilization	This graph shows the total number of packets (per second) the CPU can handle at once (1)
Processor Utilization	This graph shows the number of Modbus/TCP or EtherNet/IP messages per second for the client or server (1)
System Bandwidth Monitor	These graphs show the percentage of bandwidth consumed by the Modbus messaging and I/O Scanning services (1)



Port Statistics

Port Statistics page

This page shows the statistics for each port on the CPU. This information is associated with the configuration of the Ethernet ports and the configuration of the service/extended port.

The names of active ports are green. The names of inactive ports are gray.

The information is reset or expanded with these buttons:

- Reset Counters: Resets all dynamic counters to 0.
- Detail View: Expands the list of port statistics.

I/O Scanner page

The objects on this page provide information on the scanner status and connection statistics.

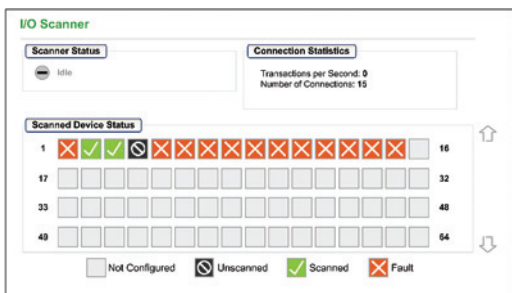

I/O Scanner

Field	Description	
Scanner Status	Enabled	The I/O scanner is enabled
	Disabled	The I/O scanner is disabled
	Idle	The I/O scanner is enabled but not running
	Unknown	The I/O scanner returns unexpected values from the device
Connection Statistics	Transactions per second	
	Number of connections	
Scanned Device Status	Colors that appear in each block indicate these states for specific remote devices	
	Gray	There is an unconfigured device
	Black	The scanning of the specific device has been intentionally disabled
	Green	A device is being scanned successfully
	Red	A device that is being scanned is returning detected errors

(1) Move the mouse over the dynamic graphs to see the current numeric values.

Messaging						
Messaging Statistics						
Messages Sent:	6513	Messages Received:	6516	Success Rate:	100.00%	
Active Connections						
Remote Address	Remote Port	Local Port	Type	Mgs. Sent	Mgs. Received	Errors
127.0.0.1	65359	502	0	2173	2172	0

Messaging

QoS	
Service Status	
Enabled	
Precision Time Protocol	
DSCP PTP Event Priority	15104
DSCP PTP General	12032
EtherNet/IP Traffic	
DSCP Value for I/O data Schedule Priority Messages	14080
DSCP Value for Explicit Messages	6912
Detail View	
Modbus/TCP Traffic	
DSCP Value for I/O Messages	11008
DSCP Value for Explicit Messages	6912
Network Time Protocol Traffic	
DSCP Value for Network Time	15104

QoS

Diagnostic web pages (continued)

Messaging page

This page shows current information for open TCP connections on port 502:

- **Messaging Statistics:** This field contains the total number of sent and received messages on port 502. These values are not reset when the port 502 connection is closed. Therefore, the values indicate the number of messages that have been sent or received since the module was started.
- **Active Connections:** This field shows the connections that are active when the Messaging page is refreshed.

QoS (quality of service) page

This page displays information about the QoS service. This service is configured in Unity Pro. When QoS is enabled, the module adds a differentiated services code point (DSCP) tag to each Ethernet packet it transmits, thereby indicating the priority of that packet.

Network Time Service page

This page displays information about the NTP service. This service is configured in Unity Pro. The Network Time Service synchronizes computer clocks over the Internet for the purposes of event recording (sequencing events), event synchronization (triggering simultaneous events), or alarm and I/O synchronization (timestamping alarms).

Field	Description	
Service Status	Running	The NTP service is correctly configured and running
	Disabled	The NTP service is disabled
	Unknown	The NTP service status is unknown
Server Status	Green	The server is connected and running
	Red	A bad server connection is detected
	Gray	The server status is unknown
Server Type	Primary	A primary server polls a master time server for the current time
	Secondary	A secondary server requests the current time only from a primary server
DST Status	Running	DST (daylight saving time) is configured and running
	Disabled	DST (daylight saving time) is disabled
	Unknown	The DST status is unknown
Current Date	This is the current date in the selected time zone	
Current Time	This is the current time in the selected time zone	
Time Zone	This field shows the time zone in terms of plus or minus Universal Time Coordinated (UTC)	
NTP Service Statistics	These fields show the current values for service statistics	
	Number of Requests	This field shows the total number of requests sent to the NTP server
	Success Rate	This field shows the percentage of successful requests out of the total number of requests
	Number of Responses	This field shows the total number of responses received from the NTP server
	Last Error	This field contains the code of the last error that was detected during the transmission of an email message to the network
	Number of Errors	This field contains the total number of email messages that could not be sent to the network or that have been sent but not acknowledged by the server

Network Time Service		
Service Status	Server Status	Server Type
Unknown	0.33.0.65	Unknown
DST Status	Current Date	Current Time
Unknown	7/24/2013	08:22:47
Time Zone		
UTC+02:00		
NTP Service Statistics		
Number of Requests: 1835026	Number of Responses: 655426	Number of Errors: 498775
Success Rate: 8.33%	Last Error: 0x01	

Network time service

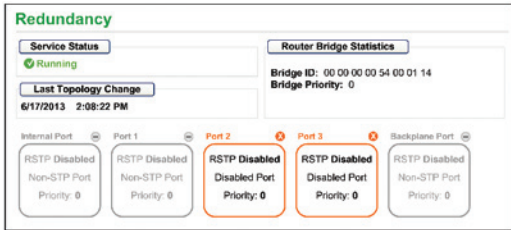

Redundancy

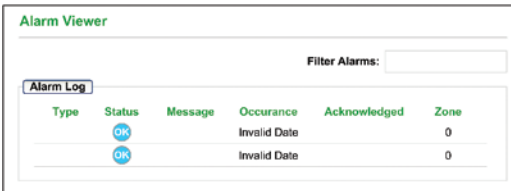

Alarm Viewer

Diagnostic web pages (continued)

Redundancy page

This page displays values from the RSTP configuration in Unity Pro.

Parameters	Description	
Service Status	This is the status (Enabled or Disabled) of the RSTP bridge on the corresponding CPU	
Last Topology Change	These values represent the date and time that the last topology change was received for the corresponding Bridge ID	
Redundancy Status	Green	The designated Ethernet port is learning or formatting information
	Yellow	The designated Ethernet port is discarding information
	Gray	RSTP is disabled for the designated Ethernet port
Router Bridge Statistics	Bridge ID	This unique bridge identifier is the concatenation of the bridge RSTP priority and the MAC address
	Bridge Priority	In Unity Pro, configure the RSTP operating state of the Bridge ID

Alarm Viewer page

The Alarm Viewer page reports detected errors in the application. Information about alarm objects can be read, filtered, and sorted on this page. The type of information displayed by the Alarm Viewer is adjusted in the Filter Alarms box.

Field	Description	
Type	This column describes the alarm type	
Status	STOP	You need to acknowledge the alarm
	ACK	An alarm has been acknowledged
	OK	An alarm does not require acknowledgment
Message	This column contains the text of the alarm message	
Occurance	This column contains the date and time that the alarm occurred	
Acknowledged	This column reports the acknowledged status of the alarm	
Zone	This column contains the area or geographical zone from which the alarm comes (0: common area)	



BMXNOC0402

3

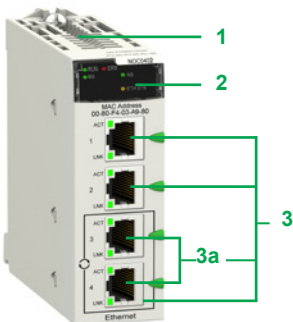

BMXNOC0402

Presentation

The **BMXNOC0402** (1) network module acts as an interface between the M580 PLC and other Ethernet network devices via the Modbus/TCP and EtherNet/IP communication protocols.

The standard format **BMXNOC0402** (1) network module occupies a single slot in the rack of the Modicon M580 platform. This module has to be installed in the main Ethernet + X-bus backplane rack.

Functions

The **BMXNOC0402** (1) module offers the following functions:

- Modbus/TCP and EtherNet/IP protocols operating simultaneously
- Ring topologies on 2 Ethernet ports using RSTP (Rapid Spanning Tree Protocol)
- Priority of Ethernet packets using QoS (Quality of Service) service
- Automatic module configuration recovery using FDR (Fast Device Replacement) service
- Embedded Web server for application monitoring and module diagnostics
- Sharing data between PLCs
- Network management using SNMP (Simple Network Management Protocol)

Description

The front panel of the **BMXNOC0402** (1) module features:

- 1 A screw for locking the module in a slot in the rack.
- 2 A display block with 5 LEDs:
 - RUN LED (green): Operating status
 - ERR LED (red): Error detected
 - MS LED (green/red): Module status
 - NS LED (green/red): Network connection status
 - ETH STS LED (amber): Ethernet link status
- 3 Four RJ45 connectors for connection to the Ethernet network. The two bottom connectors **3a** support ring topologies (RSTP protocol).

Each RJ45 connector has two associated LEDs:

- LNK LED (yellow): Ethernet link established
- ACT LED (green): Transmission/reception activity

(1) The **BMXNOC0402** communication module will be replaced by the **BMENOC03•1** modules during the 2nd quarter of 2014.

Modicon M580 automation platform

Modbus/TCP and EtherNet/IP network module



BMXNOC0402

References

Description	Data rate	Reference	Weight kg/lb
EtherNet/IP, Modbus/TCP network module	10/100 Mbps	BMXNOC0402 (1)(2)	0.345/ 0.761

- (1) The Unity Pro configuration tool is supplied on CD-ROM with the module. This software is used to update the Unity Pro hardware catalog (addition of the new module DTMs).
- (2) The **BMXNOC0402** communication module will be replaced by the **BMENOC03•1** modules during the 2nd quarter of 2014.

Modicon M580 automation platform

Web servers and gateways

Applications Standalone Web Gateway/Server module for remote access

Type FactoryCast Gateway ETG10●0



Target products Type Any device supporting Modbus Any device supporting Uni-Telway

Network/Remote access services	Remote access	Intranet or via external modem and integrated RAS function	Intranet or modem, external modem and integrated RAS function
	Gateway function	Remote programming, downloading via FTP, access to Web server via web browser	
	Serial protocols	Ethernet to Modbus serial Modem to Modbus serial and Ethernet	Ethernet to Uni-Telway serial Modem to Uni-Telway and Ethernet
	Ethernet protocols	Modbus master	Uni-Telway slave
	TCP/IP protocols	Modbus/TCP	Modbus/TCP Uni-TE (Premium, Micro)
	Security	BootP/DHCP, DNS, SNMP agent, SMTP client, NTP client (1), FTP	BootP/DHCP, DNS, SNMP agent, SMTP client, NTP client (1), FTP
		Protection by IP address filtering and passwords	

Web server	Characteristics	HTTP and FTP server, 8 MB memory available for user, hosting of user Web pages and documents (doc, pdf, Excel)	
-------------------	-----------------	--	--

Predefined services	Configuration	Via Web Designer software or predefined Web pages	
	Diagnostics	Serial device diagnostics via predefined Web pages	
	Monitoring	Monitoring via animation tables Display of PLC Unity program in a Web page	Monitoring of devices and application via animation tables (read/write variables) Display of PLC Unity program in a Web page
	Alarm management	-	

Customizable services	Graphic views	Graphic monitoring via animated views (integrated graphic editor)	
	Unity Pro operator screen	-	
	User Web pages	Graphic monitoring via animated Web pages created by the user	

Advanced and HMI services	Calculation scripts	-	
	E-mail service	Alarm notification by e-mail	
	Data logging	-	
	Database connection	-	
	Report service	-	
	Recipe service	-	

Application development software Web Designer (supplied with each module)



Web Designer

References	TSXETG1000	TSXETG1010
	www.schneider-electric.com	

Catalog or website www.schneider-electric.com

(1) Except with TSXP57103M/153M Modicon Premium processors, which do not have the NTP service.

Applications Standalone Web Gateway/Server modules for remote access

Type FactoryCast HMI Gateway ETG30●●



Target products Any Modicon PLC or third-party device supporting Modbus

Network/Remote access services	Intranet or modem, external modem and integrated RAS function	Intranet or modem RTC modem and integrated RAS function	Intranet or modem GSM modem and integrated RAS function
	Remote programming, downloading via FTP, access to Web server via web browser		
	Ethernet to Uni-Telway serial, modem to Modbus serial and Ethernet		
	Modbus master		
	Modbus/TCP		
	DHCP, DNS, SNMP agent, SMTP client, NTP client (1), FTP		
Protection by IP address filtering and passwords			

Web server	Characteristics	HTTP and FTP server, 32 MB memory available for user Web pages, memory expansion using Compact Flash cards 1 GB max., hosting of user Web pages and documents (doc, pdf, Excel)	
-------------------	-----------------	---	--

Predefined services	Configuration	Via Web Designer software or predefined Web pages	
	Diagnostics	Network diagnostics, serial and Ethernet device diagnostics via predefined Web pages	
	Monitoring	Monitoring of devices and application via animation tables (read/write variables) Display of PLC Unity program in a Web page	
	Alarm management	-	

Customizable services	Graphic views	Graphic monitoring via animated views (integrated graphic editor)	
	Unity Pro operator screen	-	
	User Web pages	Graphic monitoring via animated Web pages created by the user	

Advanced and HMI services	Arithmetic and logical scripts	-	
	Alarm notification by e-mail/SMS	Alarm notification by e-mail/SMS	
	Data logging	Data recorded in the module with date and time stamping (CSV files)	
	Database connection	Direct recording in an SQL, Oracle, or MySQL server	
	Report service	Dynamic HTML report management	
	Recipe service	Management of "Recipe" data (storage and review locally or in remote database)	

Application development software Web Designer (supplied with each module)



Web Designer

References	TSXETG3000	TSXETG3010 (PSTN modem)	TSXETG3021 (GSM900/1800 MHz band) TSXETG3022 function (GSM850/1900 MHz band)
	www.schneider-electric.com		

Catalog or website www.schneider-electric.com

(1) Except with TSXP57103M/153M Modicon Premium processors, which do not have the NTP service.

Modicon M580 automation platform

Modbus Plus Proxy module

Presentation

The **TCSEGDB23F24FA** Modbus Plus Proxy module is a network gateway that allows Modicon M340 and M580 PLCs to communicate with existing Modbus Plus devices.

It is not necessary to modify the applications for these devices to communicate with the Modicon M340 and M580 PLCs, since the module automatically addresses the platforms and the various communication functions between the M340/M580 and other PLC platforms (especially 984LL).

The Modbus Plus Proxy offers Modbus Plus PLC users the chance to integrate the M340 and M580 PLCs easily into their Modbus Plus network and thus to access advanced communications via Ethernet, or to migrate gradually from other PLC models to Modicon M340/M580 and Unity.

3

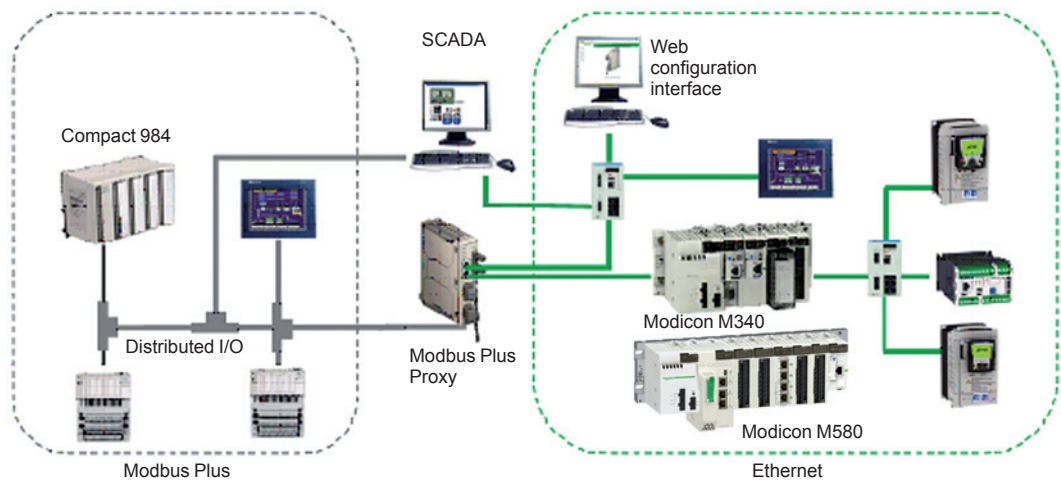

Key benefits

Reduced startup time

- Online configuration of the proxy via a simple Web browser
- Setup Web pages similar to the screens of the Modbus Plus Peer Cop utility, accessible under Concept/Unity for the Global Data transaction
- Simpler data exchange with Global Data transactions performed on all network nodes
- Point-to-point communication without programming with Peer Cop

Increased network reliability and maintainability

- Standard diagnostics provide data on all network nodes for easy troubleshooting
- Dual Modbus Plus ports provide Modbus Plus network redundancy

Reduced total cost of ownership

- Helps protect your investment in Modbus Plus while migrating to Ethernet
- Dual Ethernet ports allow connection of both the M340 or M580 PLC and the configuration PC to the proxy, without any additional switches

Modicon M580 automation platform

Modbus Plus Proxy module

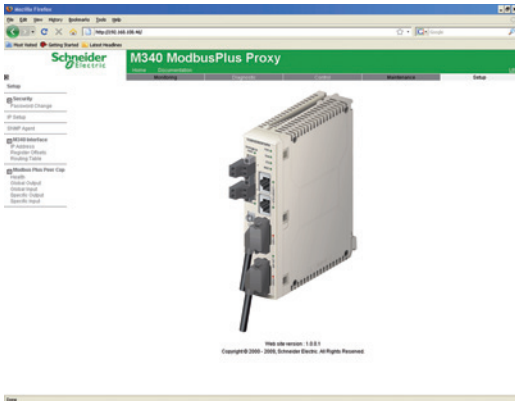

Embedded Web server

Web server functions

The Modbus Plus Proxy module includes an embedded Web server that can be used to perform diagnostics and configure the module connection. All data is presented in the form of standard Web pages in HTML format. To access a Web page, you need Internet Explorer (version 6.0 or later) and Java (version 1.5 or later).

Embedded Web server functions

- 1 - Setup: The Setup pages allow you to define the parameters for several different module services, including security, IP, SNMP, Global Data, Peer Cop and Ethernet ports.
- 2 - Diagnostics: These network diagnostic pages contain Ethernet, TCP, and SNMP statistics, as well as a log of the diagnostics performed.

Complementary characteristics

The following characteristics complement those introduced in the communication selection guide on page 3/5:

- External power supply voltage: 19.2...31.2 V $\overline{\text{---}}$
- Consumption: 300 mA max.
- Dissipated power: 6.2 W
- Conformity with standards: UL 508, CSA 22.2 No. 142 (cUL), EMI EN 55011, EN 61131-2, C-Tick

References

System and network requirements

- Unity Pro XL programming software (version 3.x or later) (1)
- Internet Explorer (version 6.0 or later)
- Java (version 1.5 or later)
- Microsoft Windows XP or Vista

Modicon M340 processors:

- BMXP342020 (Modbus and Ethernet version)
- BMXP3420302 (CANopen and Ethernet version)
- BMXP3420302CL (CANopen and Ethernet version) (2)

Modicon M580 processors:

- BMEP581020
- BMEP582020
- BMEP582040
- BMEP583020
- BMEP583040
- BMEP584020
- BMEP584040

Ethernet Modicon M340 communication modules:

- BMXNOE0100
- BMXNOE0110
- BMXNOC0401

Modicon M580:

- BMXNOC0402 (3)

Modicon Modbus Plus Proxy module

Description	Type	Reference	Weight kg
Modbus Plus Proxy module for Modicon M340 and M580 PLCs	Standard	TCSEGDB23F24FA	–
supplied with 2 front-mounted power supply connectors (2 positions)	Conformal coating	TCSEGDB23F24FK	–

(1) Unity V8.0 or later with M580
 (2) Memory card to be ordered separately for the **BMXP3420302CL** processor (see our website www.schneider-electric.com).
 (3) The **BMXNOC0402** communication module will be replaced by the **BMENOC03•1** modules during the 2nd quarter of 2014..



TCSEGDB23F24FA

Modicon M580 automation platform

Profibus DP V1 and Profibus PA buses

Profibus Remote Master module

3

Profibus DP fieldbus

Profibus DP is one of the most widely used fieldbuses in industry. Based on a master/slave protocol, only master stations, sometimes called active stations, have the right to access the bus, with slave, or passive, stations being limited to responding to interrogations.

Version V0 of Profibus only allows cyclic exchanges with I/O, whereas version V1 offers an acyclic message handling channel that can be used for device adjustment or diagnostics during operation.

The physical link is a single shielded twisted pair, but numerous interfaces are available for creating all sorts of topologies - tree, star, or ring - including those using optical fiber or a non-physical link.

Gateways can be used to communicate transparently with Profibus PA, one of the most commonly used standards in process applications for connecting instrumentation. Profibus PA can be used to supply devices across the network and also to install sensors in potentially explosive zones (ATEX).

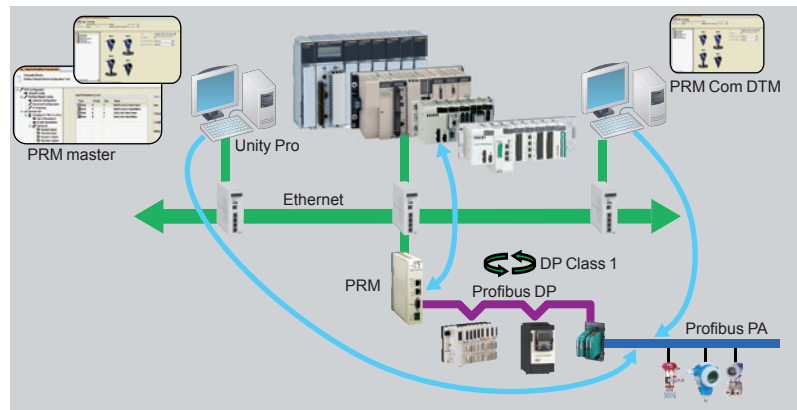

Profibus Remote Master (PRM) module

Presentation

The Profibus Remote Master (PRM) module is connected to the Ethernet Modbus TCP/IP network via its integrated 2-port switch, as close as possible to the process and the instrumentation.

The PRM module can be used to connect Modicon Quantum, Premium, M580, and M340 PLCs to Profibus DP V1 via the I/O scanner function. Irrespective of the type of PLC, only one product reference is required and setup is identical, thus reducing training and maintenance costs.

Two versions are available, standard and tropicalized, so as to adapt to any type of environment.

The PRM module is open to Asset Management tools. A dedicated communication DTM is supplied with the product, thus allowing any compatible FDT standard tool to remotely adjust devices on Profibus using Ethernet.

Configuration

From a single Unity tool, the user can create the Profibus configuration, the PLC application, and configure or calibrate devices.

The latter are integrated in the Unity catalog via their DTMs if they exist, or their *gsd* files.

The I/O scanner configuration is created implicitly in Unity Pro using the Profibus configuration. The parameters assigned by default help optimize performance, as well as the consistency of I/O data in the PLC application, irrespective of the PLC platform.

Similarly, the I/O variables defined and presymbolized in the DTMs can be used directly in the application. Finally, the screens integrated in Unity Pro, together with the diagnostic functions integrated in the device DTMs simplify application maintenance.

Modicon M580 automation platform

Profibus DP V1 and Profibus PA buses

Profibus Remote Master module

Profibus Remote Master (PRM) module (continued)

Connectable devices

The following Schneider Electric devices can be connected to this bus:

- TeSys U and TeSys T starter-controllers
- Momentum and Modicon STB distributed I/O
- Altivar 312/61/71 variable speed drives for asynchronous motors
- Lexium 05 and 32 servo drives for brushless motors
- Altistart ATS 48 soft start-soft stop units
- LMC Packdrive 3
- Osicoder
- Any third-party device compatible with Profibus DP and PA standard profiles

Limitations

Once saved, the Unity project incorporates all the Profibus parameters as well as those of the slaves connected to the bus. Modicon Quantum, Premium, M580, and M340 PLCs are capable of embedding all this data so that an empty Unity terminal without any applications is able, after a simple transfer from the PLC, to locate the whole application, including the slave parameters. This function is called ETS (*Empty Terminal Service*).

In certain cases, it may be that the memory size required to save the device parameters exceeds the PLC memory capacity (signaled by a "memory full" message during the build). This is particularly likely on devices which have DTM (the most common instrumentation on PA). Typically, each device of this type takes up around 20 KB of the PLC memory.

It is therefore essential to create a memory map according to the type of configuration used and possibly adapt it accordingly, either by increasing the amount of memory dedicated to the application (by reducing the zone allocated to data), or by increasing the overall memory via cartridges available in the catalog.

If the ETS function is not required, Unity Pro can also be configured in such a way as to reduce the size of the embedded data by disabling comments and animation tables, or by disabling the upload function so that the application does not include data relating to DTMs. In this case, the upload from an empty terminal function is no longer available.

References

The Profibus Remote Master module is supplied with a CD-ROM, which includes:

- The PRM master DTM for operating the PRM on Quantum, Premium, or M340 starting from Unity V5.0
- The PRM Gateway DTM for operating the PRM on M580 starting from Unity V8.0
- The generic Profibus DTM for managing devices not provided with DTM but just with gsd files
- The PRM communication DTM providing total communication transparency from any FDT tool (out of Unity) up to the Profibus devices
- A library of DFBs for PRM management or support of explicit DP V1 communication with Profibus slaves
- PRM technical documentation

Profibus Remote Master modules

Description	Type	Reference	Weight kg/lb
Profibus Remote Master modules	Standard	TCSEGA23F14F	0.620/ 1.367
	Ruggedized (1)	TCSEGA23F14FK	0.620/ 1.367

Profibus DP bus connection components

Description	Type	Reference	Weight kg/lb
Distributed I/O on Profibus DP bus	Modicon STB network interface module	STBNDP2212	0.140/ 0.309
	Momentum communication module	170DNT11000	0.070/ 0.154
Connectors for remote I/O communication module	Line terminators	490NAD91103	–
	In-line connector	490NAD91104	–
	In-line connector	490NAD91105	–

Description	Length	Reference	Weight kg/lb
Profibus DP connection cables	100 m/328.08 ft	TSXPBSCA100	–
	400 m/1,312.33 ft	TSXPBSCA400	–

(1) Conformal coating and extended operating temperatures between - 25 and + 70 °C/ - 13 and 158 °F (see ruggedized module characteristics, page 5/2)



TCSEGA23F14F



490NAD91103

Unity Pro software

Selection guide page 4/2

- Presentation..... page 4/4
- FDT/DTM..... page 4/4
- Programming languages page 4/5
- Functions page 4/6
- Communication drivers page 4/16
- Windows OS compatibility..... page 4/16
- Unity Pro update page 4/17
- References page 4/18

Unity EFB Toolkit software

- Presentation, setup page 4/22
- References page 4/23

Unity DIF software

- Presentation, setup page 4/24
- References page 4/25

Unity Loader software

- Presentation..... page 4/26
- References page 4/27

Unity Specific libraries

- Presentation..... page 4/28
- References page 4/29

OPC data server software

- Presentation..... page 4/30
- Architectures page 4/31
- Setup page 4/33
- Functions page 4/34
- References page 4/35
- Time stamping system page 4/36
- Presentation page 4/36
- Architectures page 4/36
- Performance..... page 4/37





Unity Pro

4

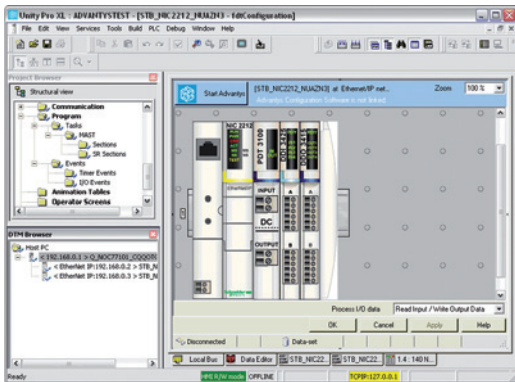

DTM editor (Modicon STB Island)

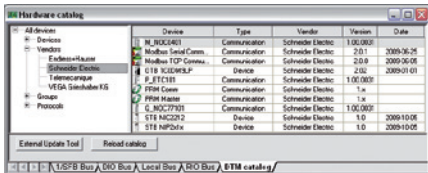

DTM hardware catalog

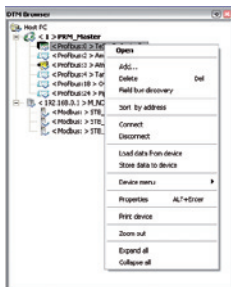

DTM browser and DTM context menu

Presentation

Unity Pro is the common programming, debugging and operating software for the Modicon M340, M580, Premium and Quantum PLC ranges.

Unity Pro is multitasking software offering the following features:

- All-in-one software
- Five IEC 61131-3 programming languages
- LL 984 programming language
- Integrated, customizable DFB library
- PLC simulator on PC for program validation prior to installation
- Built-in tests and diagnostics
- Wide range of online services

FDT/DTM function

Unity Pro facilitates integration of fieldbus architectures into engineering control systems using FDT/DTM technology:

- FDT (*Field Device Tool*) is the container which supports the device DTMs.
- DTM (*Device Type Manager*) is the configuration tool for devices with integrated graphic interfaces. It contains the properties specific to each device.

In addition to the FDT/DTM standard, Unity Pro uses specific information from the Master DTM created for the Profibus Remote Master (PRM) module and the Modbus/TCP and EtherNet/IP network module BMXNOC0401.

Use of the Master DTM allows Unity Pro to perform the following actions:

- Manage the PLC I/O scan
- Create the application variables based on the description of the process objects available from the connected DTM devices
- Manage synchronization with the PLC configuration
- Create a generic DTM from the description files (GSD or EDS)

The DTM configuration is stored in the PLC memory so that the application can be downloaded in its entirety. It is also saved in the PLC project file (STU), the archive file (STA), and the full application exchange file (ZEF).

A third-party DTM can be installed in the DTM hardware catalog. The DTM hardware catalog can be used to sort or filter the DTMs according to various criteria such as Device, Vendor, Groups or Protocols.

The DTM Browser in Unity Pro:

- Displays the fieldbus topologies in a tree structure
- Allows the user to configure the DTM devices:
 - Add and delete DTMs
 - Connect and disconnect DTMs to/from their physical devices
 - Display and print the properties of a DTM
 - Transfer DTM configuration data to and from the physical device
 - Functions specific to the DTM, via the Device menu

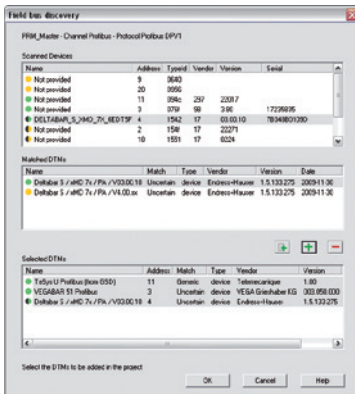

Fieldbus lookup screen

FDT/DTM function (continued)

The fieldbus lookup function scans the physical devices in a fieldbus network and adds the selected devices to the DTM Browser.

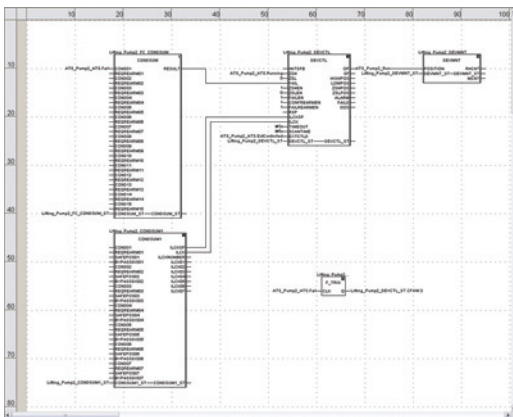

FBD language editor

Programming languages

The five IEC 61131-3 compliant languages

The five graphical or textual languages available in Unity Pro are used for programming Modicon M340, Modicon M580, Premium and Quantum automation platforms.

The three graphical languages are:

- Ladder (LD) language
- Function Block Diagram (FBD)
- Sequential Function Chart (SFC) or Grafcet

The two textual languages are:

- Structured Text (ST)
- Instruction List (IL)

For these five languages, you can use the standard set of instructions compliant with IEC standard 61131-3 to create applications which can be transferred from one platform to another. Unity Pro software also provides extensions to this standard set of instructions. As they are specific to Modicon M340, Modicon M580, Premium and Quantum PLCs, these extensions support the development of more complex applications in order to maximize the potential of the specific features of each of these platforms.

LL984 language

LL984 (Ladder Logic 984) language enables migration from legacy Modicon ranges. It is used to program Modicon M340 and Quantum automation platforms.

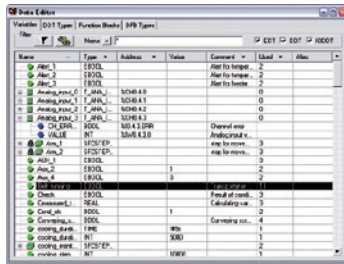

Data editor

Data editor

The data editor provides a single tool for performing the following editing tasks:

- Declaration of data including variables and function blocks (declaration of their type, instances and attributes).
- Use and archiving of function block data types in different libraries.
- Hierarchical view of data structures.
- Searching, sorting and filtering of data.
- Creation of a hyperlink to access a description from any variable comment.

The data is displayed in four tabs:

- “Variables” tab for the creation and management of the following data instances: Bits, words, double words, inputs/outputs, tables and structures.
- “DDT Types” tab for the creation of derived data types (tables and structures).
- “Function Blocks” tab for the declaration of EFBs and DFBs.
- “DFB Types” tab for the creation of DFB user function block data types.

Each data element has several attributes, of which:

- The variable name and type are mandatory.
- The comment, physical address in the memory and initial values are optional.

The data editor columns can be configured (number of columns, order). The attributes associated with a variable can be displayed in a properties window.

This editor can be accessed at any time during programming by selecting variables for data modification or creation.

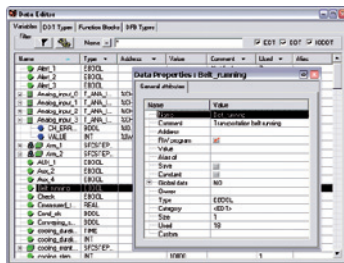

Data properties

4

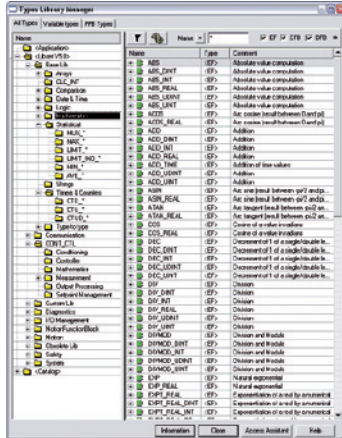

Standard function block libraries

Function block libraries

The function and function block libraries manager contains the elements provided with Unity Pro software. Functions and function blocks are organized into libraries, which themselves consist of families. Depending on the type of PLC selected and the processor model, users will have a subset of these libraries available to write their applications. However, the “Base Lib” library contains a set of functions and function blocks, for the majority of which compatibility is independent of the platforms. In particular, it contains the blocks compliant with IEC 61131-3. The “Base Lib” library is structured into families:

- Timers and counters
- Process control on integers
- Table management
- Comparison
- Date and time management
- Logic processing
- Mathematical processing
- Statistical processing
- Character string processing
- Type-to-type data conversion

The “Base Lib” library, which covers standard automation functions, is supplemented by other, more application-specific libraries and platform-specific functions:

- **Communication library**, providing an easy means of integrating communication programs from PLCs with those used by HMIs from the PLC application program. Like other function blocks, these EFBs can be used in any language to exchange data among PLCs or to deliver data to be displayed on an HMI.
- **Process control library**. The CONT_CTL library can be used to set up process-specific control loops. It offers controller, derivative and integral control functions and additional algorithms, such as EFBs for calculating mean values, selecting a maximum value, detecting edges or assigning a hysteresis to process values, etc.
- **Diagnostics library**, which can be used to monitor actuators and contains EFBs for active diagnostics, reactive diagnostics, interlocking diagnostics, permanent process condition diagnostics, dynamic diagnostics, monitoring of signal groups, etc.
- **I/O management library**, providing services to handle information exchanged with hardware modules (formatting data, scaling, etc.).
- **Motion Function Blocks library**, containing a set of predefined functions and structures to manage motion controlled by drives and servo drives connected on CANopen.
- **Motion library** for motion control and fast counting.
- **System library**, which provides EFBs for the execution of system functions, including: evaluation of scan time, availability of several different system clocks, SFC section monitoring, display of system state, management of files on the memory cartridge of the Modicon M340 processor, M580 processor, etc.
- Finally, a library named “obsolete”, containing all function blocks used by legacy programming software needed to perform application conversions.

Management of user standards

Users can create libraries and families in order to store their own DFBs and DDTs. This enhancement allows users to take advantage of programming standards adapted to their needs, along with version management. This means that it is possible to:

- Check the version of the elements used in an application program against those stored in the library
- Perform an upgrade, if necessary

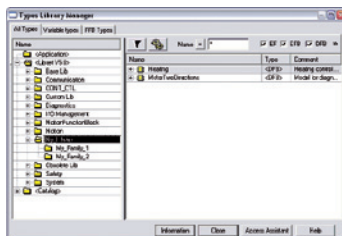

User libraries

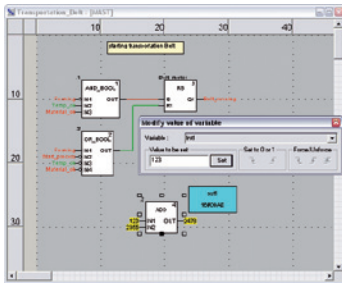

Dynamic animation/adjustment

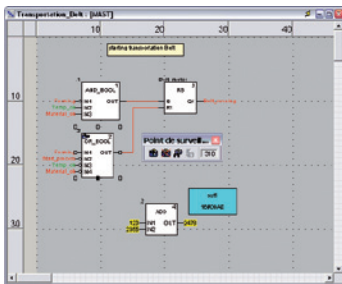

Watchpoint

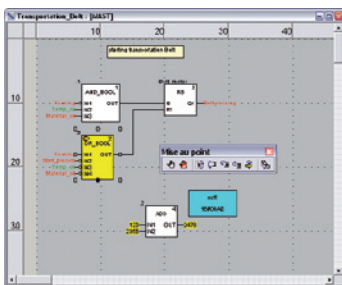

Breakpoint/step-by-step

Debugging tools

Unity Pro software offers a complete set of tools for debugging Modicon M340, M580, Premium or Quantum applications. A tool palette provides direct access to the main functions:

- Dynamic program animation.
- Setting of watchpoints or breakpoints (not authorized in event-triggered tasks).
- Step-by-step program execution. A function in this mode enables section-by-section execution. Instruction-by-instruction execution can be launched from the previous breakpoint. Three execution commands are therefore possible when the element to be processed is a subroutine (SR) or DFB user block instance:
 - Step Into: this command is used to move to the first element of the SR or DFB
 - Step Over: this command is used to execute the entire SR or DFB
 - Step Out: this command is used to move to the next instruction after the SR or DFB element
- Independent execution of the master (MAST), fast (FAST), auxiliary (AUX) and event-triggered (EVTi) tasks.

Animation of program elements

Dynamic animation is managed section-by-section. A button on the toolbar is used to activate or deactivate animation for each section.

When the PLC is in RUN, this mode can be used to view simultaneously:

- The animation of a program section, regardless of the language used.
- The variables window containing the application objects created automatically from the section viewed.

Animation table

Tables containing the variables of the application to be monitored or modified can be created by data entry or initialized automatically from the selected program section. The tables can be stored in the application and retrieved from there at a later date.

Unity Pro can be used to save, import and export Animation tables with predefined set values. As it allows population of set values along with current values and vice versa in the PLC, the Animation tables can be used as templates to make the application easier to tune.

Debugging DFB user function blocks

The parameters and public variables of these blocks are displayed and animated in real time using animation tables, with the possibility of modifying and forcing the required objects.

In exactly the same way as with other program elements, the watchpoint, breakpoint, step-by-step execution and program code diagnostics functions can be used to analyze the behavior of DFBs. Setting a breakpoint in a DFB user function block instance stops execution of the task containing this block.

Debugging in Sequential Function Chart (SFC) language

The various debugging tools are also available in SFC language. However, unlike other sections (IL, ST, LD or FBD) an SFC section executed step-by-step does not stop execution of the task but instead freezes the SFC chart. Several breakpoints can be declared simultaneously within a single SFC section.

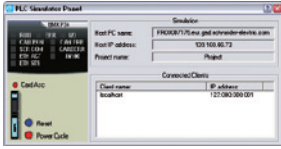

Simulator control panel

PLC simulator

Unity Pro's integrated simulator can be used to test the application program for Modicon M340, M580, Premium or Quantum PLCs from the PC terminal without having to connect to the PLC processor. The functions provided by the debugging tools are available for debugging the master, fast and auxiliary tasks. As the simulator does not manage the PLC I/O, animation tables can be used to simulate the state of inputs by forcing them to 0 or 1. The simulator can be connected to third-party applications via an OPC server with OFS (OPC Factory Server) software.

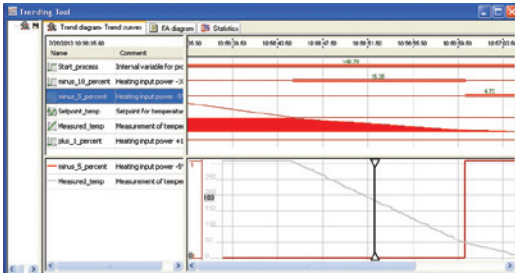

Trending tool control panel

Trending tool

The trending tool allows easy monitoring of variables by detecting operating problems or improving process performance. You can select any variable in your application and start acquisition, save records, and analyze records with integrated tools or Excel. The PLC mast scan can scan up to 16 variables.

4

Documentation editor

The documentation editor is based on the Documentation Browser, which shows the file structure in tree form. It allows all or part of the application file to be printed on any graphics printer accessible under Windows and using True Type technology, in A4 or US letter print format.

The documentation editor supports the creation of user-specific files using the following headings:

- Title page
- Contents
- General information
- Footer
- Configuration
- EF, EFB and DFB type function blocks
- User variables
- Communication
- Project structure
- Program
- Animation tables and cross-references
- Runtime screens

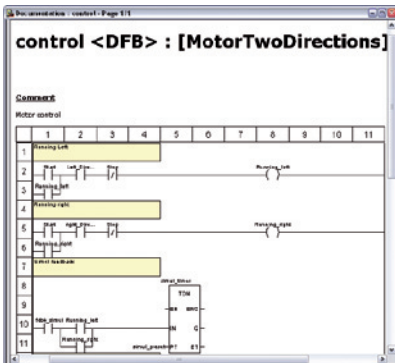

Accessing the documentation editor

Diagnostics integrated in Modicon M340, Modicon M580, Premium and Quantum automation platforms

Presentation

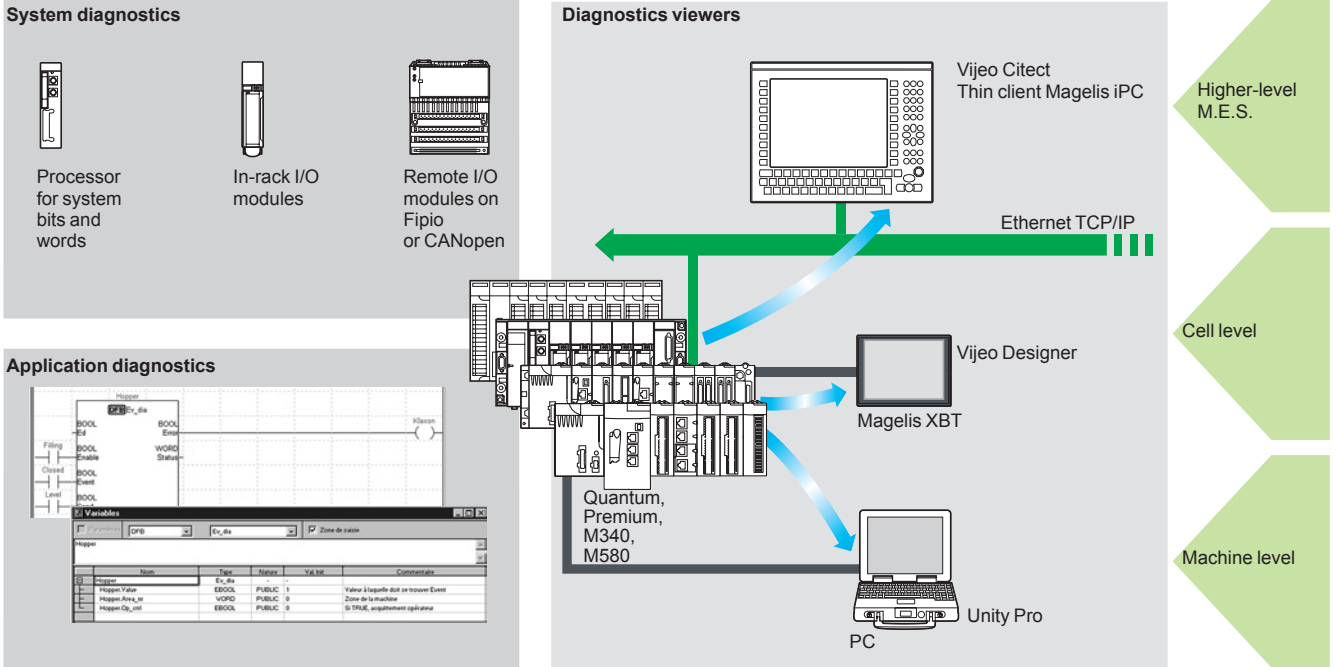

4

The diagnostics offer for Modicon M340, M580, Premium and Quantum platforms is based on the following three components:

- System diagnostics
- DFB and EFB diagnostic function blocks (for system and application diagnostics)
- Error message display system, called viewers, supplied as a standard component of Magelis XBT terminals, Vijeo Citect supervisory software and Unity Pro setup software

System diagnostics

The system diagnostics for the Modicon M340, M580, Premium and Quantum platforms support the monitoring of system bits/words, I/O modules and activity times (minimum/maximum) of SFC steps. By simply choosing the relevant option during application configuration, any event will generate time-stamped messages logged in the diagnostic buffer of the PLC.

These events are displayed automatically in a diagnostics viewer (1) without requiring any additional programming.

With Unity Pro integrated diagnostics, this function can be used to perform first level diagnostics of the elements in the configuration, up to and including each I/O module channel.

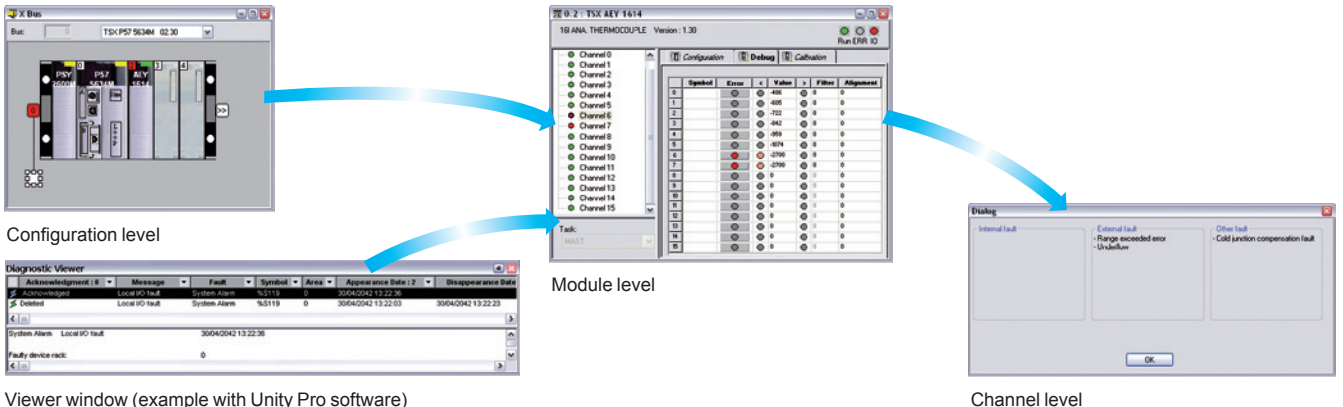

(1) Diagnostics viewers are tools for displaying and acknowledging diagnostic error messages. They are supplied as a standard component of Unity Pro and Vijeo Designer software, with Magelis terminals and with the PLC Web server that can be accessed via a thin client Magelis iPC.

4

Modifying the program with the PLC in RUN mode

With Unity Pro, changes can be made to the program when the PLC connected to the programming terminal is in RUN mode. These modifications are performed with the following operations:

- The application contained in the PLC is transferred to the PC terminal running Unity Pro, if necessary.
- Program changes are prepared. These program modifications can be of any type and in any language (IL, ST, LD, FBD and SFC), for example, addition or deletion of SFC steps or actions. The code of a DFB user function block can also be modified (however, modification of its interface is not permitted).
- These program changes are updated in the PLC (in RUN mode).

This function makes it possible to add or modify program code and data in different parts of the application during a single modification session (thus resulting in a uniform, consistent modification with respect to the controlled process). This increased flexibility comes at a cost in terms of the amount of program memory required.

Cross-references function

Unity Pro's cross-references function, which is available in standalone mode (offline) and when connected to the PLC in Run (online), allows users to view all the elements of a PLC application when searching for any type of variable. This view indicates where the declared variable is used, as well as how it is used (for writing, reading, etc.).

This function also provides access to the Search/Replace function for variable names.

The variable search can be initialized from any editor (language, data, runtime screen, animation table, etc.).

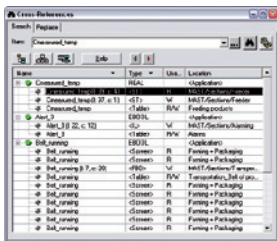

Cross-references table

Import/export function

The import/export function available in Unity Pro supports the following operations from the structural and functional project views:

- Via the import function, reuse all or part of a previously created project in the current project.
- Via the export function, copying of all or part of the current project to a file for subsequent reuse.

The files generated during export are generally in XML format (1). However, in addition to XML, variables can be exported and imported in the following formats:

- .xvm format compatible with OFS data server software.
- Source format, in an .scy file compatible with PL7 development software.
- Text format with separator (TAB) in a .txt file for compatibility with any other system.

During an import, a wizard can be used to reassign data to new instances of:

- DFB function blocks
- DDT data structures
- Simple data

In addition, when a functional module is imported, the data associated with animation tables and runtime screens is also reassigned.

The XML import function also supports the transfer of a Modicon M340, Modicon M580, Premium or Quantum PLC configuration prepared in the SIS Pro costing and configuration tool for use in the creation of a project in Unity Pro. This import function spares the user from having to redefine the PLC configuration when the PLC has already been configured with the SIS Pro tool.

(1) XML language is an open, text-based language that provides structural and semantic information.

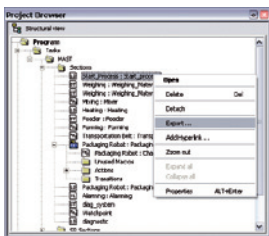

Data export shortcut menu

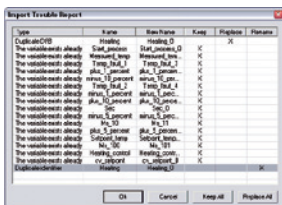

Data import wizard

Application converters

Unity Pro's integrated conversion tools can be used to convert PLC applications created with ModSoft, ProWorX, Concept and PL7 programming software to Unity Pro applications.

Concept/Unity Pro converter (Quantum PLC)

This conversion is performed with a Concept application V2.5 or later (it can also be performed in V2.11 or later, but only after an update to V2.5). In order to perform the conversion, the application must be exported to an ASCII file in Concept. The export file is converted to a Unity Pro source file automatically. This file is then analyzed by Unity Pro. At the end of the procedure, a conversion report is generated and an output window displays any conversion errors and provides direct access to the part of the program to be modified. The Concept application converter converts the application to Unity Pro, but does not guarantee that it will operate correctly in real time. It is therefore essential to test or debug all converted applications.

PL7/Unity Pro converter (Premium PLC and Atrium slot PLC)

This conversion is performed with a PL7 application V4 or later (Premium PLC or Atrium slot PLC). In order to perform the conversion, the source file (complete application or user function block) must be exported in PL7. The conversion procedure is similar to that of the Concept conversion described above.

Note: Applications created with Concept, Modsoft and ProWORX can be converted to LL984. Please contact our Customer Care Center.

Operating system update utilities

The OS-Loader software is designed for updating operating systems on Premium and Quantum platforms. It is supplied with Unity Pro software.

It is used to upgrade Unity processors and modules as well as to upgrade PL7 or Concept processors and modules to make them compatible with Unity Pro.

OS-Loader software supports:

- Premium processors
- Quantum processors
- Ethernet communication modules
- EtherNet/IP communication modules

The operating system updates are performed as follows:

- Uni-Telway RS 485 terminal link for Premium processors
- Modbus or Modbus Plus terminal link for Quantum processors
- Ethernet TCP/IP network for integrated Ethernet port on Premium processors and Premium and Quantum Ethernet modules

Note: For Modicon M340 and M580 this service is provided by Unity Loader (see page 4/26).

Online modification of the Quantum configuration

This function, also called *Change Configuration On The Fly (CCOTF)*, is used to modify the Quantum configuration online (application in RUN mode):

- Addition or removal of discrete or analog I/O modules
- Modification of configuration parameters of discrete or analog I/O modules (already present or newly installed)

The CCOTF function is supported by standalone processors for all three types of I/O architecture (local, RIO, DIO) using version 5 of Unity Pro, and for Hot Standby processors using version 4.1 or higher of Unity Pro.

The CCOTF function must first be validated in the Unity Pro configuration screen. A confirmation screen appears when the configuration has been modified online.

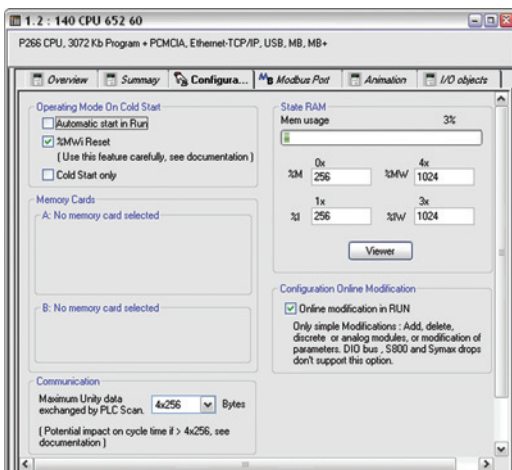

Configuration screen

Software

Unity Pro software

Small/Large/Extra Large

Programmable process control

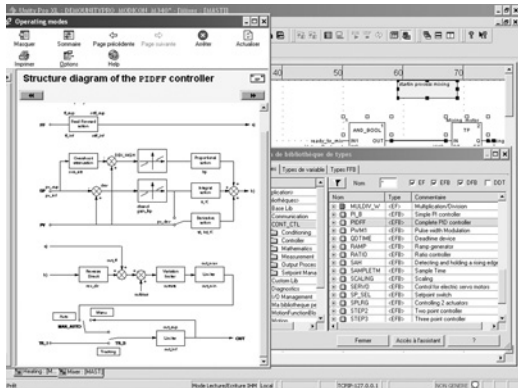

CONT_CTL, programmable process control integrated in Unity Pro

Process control in machines

Unity Pro contains **CONT_CTL**, a library of 36 function blocks used to create control loops for machine control.

The requirements for closed loop control functions in machines are adequately met by Modicon M340, Modicon M580, Premium and Quantum platforms thanks to the wealth of functions in the library and the flexibility with which function blocks can be linked together through programming. This solution therefore avoids the need for external controllers and simplifies the overall control architecture of the machine, as well as its design, roll-out and operation.

The EFs or EFBs can be used in any of the Unity Pro languages (LD, ST, IL and FBD). FBD is particularly suitable for accessing control processing operations in Unity Pro through its wizard for entering and viewing parameters and function block variables.

CONT_CTL library functions

The library consists of five function families:

- Input data conditioning
- Controllers
- Mathematical functions
- Process value processing
- Output value processing

Input data conditioning

DTIME	Pure time delay
INTEGRATOR	Integrator with limiting
LAG_FILTER	First order time lag
LDLG	Lead/lag function with smoothing
LEAD	Lead function with smoothing
MFLOW	Mass flow calculation based on the measurement of differential pressure or flow speed with pressure and temperature compensation
QDTIME	Dead time term
SCALING	Scaling
TOTALIZER	Integrator (typically of flow) until a limit (typically a volume) is reached, with automatic reset
VEL_LIM	Velocity limiter, with manipulated variable limiting

Controllers

PI_B	Basic PI controller: PI algorithm with a mixed structure (series/parallel)
PIDFF	Complete PID controller: PID algorithm with a parallel or mixed structure (series/parallel)
AUTOTUNE	Automatic tuner setting for the PIDFF (complete PID) controller or the PI_B (simple PI) controller <ul style="list-style-type: none"> □ Identification using Ziegler Nichols type method □ Modeling based on first-order process □ Building of control parameters with criterion for prioritizing either the reaction time to disturbance (dynamic) or the stability of the process
IMC	Model-based controller. The model is a first-order model with delay. This corrector is useful: <ul style="list-style-type: none"> □ When there are serious delays compared with the main time constant of the process; this scenario cannot be satisfactorily resolved by standard PID process control □ For regulating a non-linear process IMC can handle any stable aperiodic process of any order.

SAMPLETM	Control of controller startup and sampling
STEP2	Simple two-position controller
STEP3	Three-position controller for temperature regulation

Mathematical functions

COMP_DB	Comparison of two values, with dead zone and hysteresis
K_SQRT	Square root, with weighting and threshold, useful for linearization of flow measurements
MULDIV_W	Weighted multiplication/division of 3 numerical values
SUM_W	Weighted summing of 3 numerical values

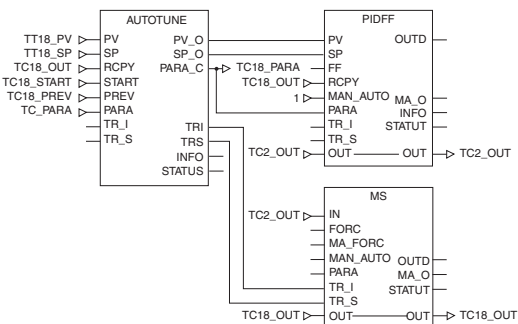

Example: PID controller with MS manual control

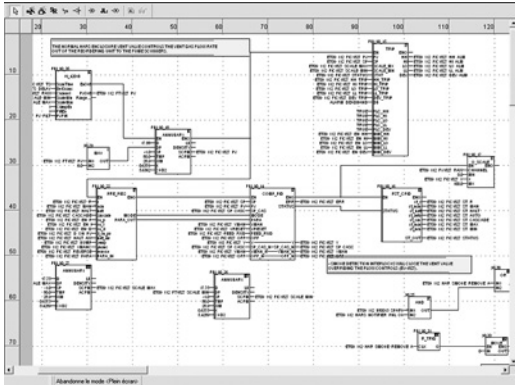

Programming in Unity Pro in offline mode

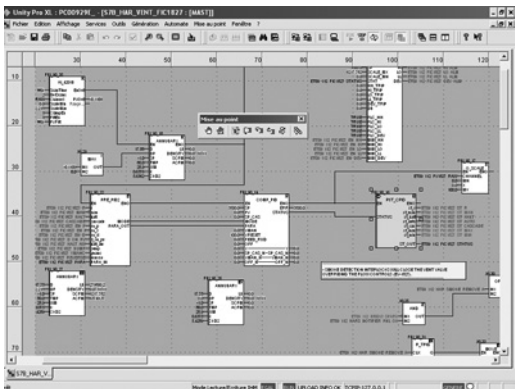

Programming in online mode

Process control in machines (continued)

CONT_CTL library functions (continued)

Process value processing

AVGMV	Moving average with fixed number of samples (50 max.)
AVGMV_K	Moving average with constant correction factor, 10,000 samples max.
DEAD_ZONE	Dead zone
LOOKUP_TABLE1	Linearization of characteristic curves using first-order interpolation
SAH	Detection of a rising edge
HYST_XXX	Detection of high threshold with hysteresis (1)
INDLIM_XXX	Detection of high and low thresholds with hysteresis (1)

Output value processing

MS	Manual control of an output
MS_DB	Manual control of an output with dead zone
PWM1	Control via pulse width modulation
SERVO	Control for servo motors
SPLRG	Control of two <i>Split Range</i> actuators

Setpoint management

RAMP	Ramp generator, with separate ascending and descending ramps
RATIO	Ratio controller
SP_SEL	Selection of setpoint value: local (operator) or <i>remote</i> (processing)

Setting up process control function blocks

Based on the sequencing of function blocks, the FBD language integrated in Unity Pro is a programming language particularly suitable for building control loops. Designers can use FBD to easily associate blocks from the CONT_CTL library with their own DFBs written in Unity Pro's ST, IL or LD language, or in C language.

Debugging, operation

All Unity Pro's standard debugging services (see page 4/9) are available. In particular, the PLC simulator can be used to check correct execution of processing offline.

Compatibility

The CONT_CTL control function block library is available in all versions of Unity Pro. It is compatible with processors in the Modicon M340, Modicon M580, Premium and Quantum ranges.

Optional specialized libraries

The CONT_CTL control function block library can be supplemented with optional specialized libraries, to meet specific needs such as predictive control, fuzzy logic controller, HVAC and mass flow calculation (see page 4/28).

Resources

The technical documentation provides many examples of how to set up programmable process control function blocks in FBD, LD, IL and ST languages.

The techniques for adjusting process control loops are described in the document "Process control, Unity V3.0" available online at www.schneider-electric.com.

(1) XXX according to the type of variable: DINT, INT, UINT, UDINT, REAL.

Software

Unity Pro software

Small/Large/Extra Large

4

Communication drivers

The most commonly used communication drivers for Modicon M340, M580, Premium and Quantum platforms are installed at the same time as the Unity Pro software.

Unity Pro also includes the following drivers, which can be installed as required (1):

Protocol - Hardware	Windows® XP Professional	Windows® 7 32-bit and 64-bit editions	Windows® 8 32-bit and 64-bit editions
Ethway - Ethernet			
Fip - FPC10 ISA card			
Fip - FPC20 PCMCIA card			
Fip adaptor - CUSBFIP			
ISAWay - PCX57 ISA card			
Modbus Serial - COM port			
PClway - Atrium TPCI57 PCI card			
Uni-Telway - COM port			
Uni-Telway - SCP114 PCMCIA card			
USB for high end PLC			
XIP - XWay on TCP/IP			

Driver available Driver not available

Upgrade kits for Concept, PL7 Pro and ProWORX software

The Concept, PL7 Pro and ProWORX upgrade kits allow users who already have one of these programs from the installed base, and who have a current subscription, to obtain Unity Pro version V4.1 software at a reduced price.

These upgrades are only available for licenses of the same type (e.g. from Concept XL group license to Unity Pro Extra Large group license).

Composition and Windows® OS compatibility

Unity Pro multilingual software packages are compatible with Windows XP (32-bit), Windows 7 (32-bit and 64-bit) and Windows 8 (32-bit and 64-bit) (2) operating systems.

They include:

- Documentation in electronic format in six languages (English, French, German, Italian, Spanish and Chinese)
- Converters for converting applications created with Concept and PL7 Pro programming software
- PLC simulator

Cables for connecting the processor to the programming PC must be ordered separately.

(1) Also available separately under reference **TLXCDDR20M**.

(2) Windows 8 can be used only in Windows 7 compatibility mode.

Software

Unity Pro software

Small/Large/Extra Large

Unity Pro update

Customers are notified automatically when a new Unity Pro update becomes available.

They can then access the software updates manager directly, download the update and install it locally on their workstation.

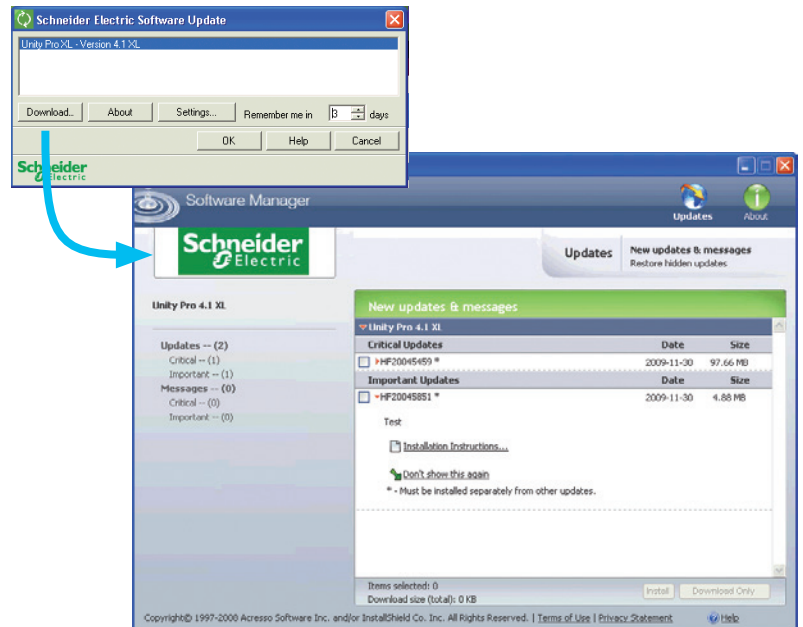

Note: The latest firmware versions can be downloaded from our website www.schneider-electric.com.



Unity Pro

4

References

Unity Pro software packages

These software packages are for programming and setting up Unity automation platforms. The software is available in three versions:

- **Unity Pro Small UNYPROSP80** (see page 4/18).
- **Unity Pro Large UNYPROLP80** (see page 4/19).
- **Unity Pro Extra Large UNYPROXLP80** (see page 4/20).

Upgrade kits for Concept, PL7 Pro and ProWORX software

These upgrade kits allow users who already have these software programs from the installed base and who have a **current subscription** to obtain Unity Pro version V8.0 software at a reduced price. These upgrades are only available for licenses of the same type (e.g. from Concept XL group license to Unity Pro Extra Large group license). See page 4/20.

Subscription renewal of Unity Pro software packages

If the user renews the subscription support **before** the end of renewal date:

- The new subscription period starts automatically at the end of the previous one.
- New versions of the software are sent to the customer during the subscription period.

Expired subscription renewal of Unity Pro software packages (1)

If the user renews the subscription **after** the end of the renewal date:

- The latest version of the software is sent to the customer.
- The customer must register within three months for the new subscription period.
- The new subscription period starts at the time of registration.
- New versions of the software are sent to the customer during the subscription period.
- There is no subscription support during the time elapsed between the two periods.

Composition and Windows OS compatibility

Unity Pro multilingual software packages are compatible with Windows XP (32-bit), Windows Vista Business Edition (32-bit) and Windows 7 (32-bit and 64-bit) operating systems. The packages comprise:

- A Unity Pro V8.0 DVD in six languages (English, French, German, Italian, Spanish and Chinese).
- A Unity Loader V8.0 CD.
- An Advantys V8.0 configuration software CD.
- A DVD containing the documentation in electronic format in six languages (English, French, German, Italian, Spanish and Chinese).
- A one-year service subscription.

Unity Pro Small version 8.0 software

For Modicon M340: **All models**
 For distributed I/O: **Modicon ETB, TM7, OTB, STB, Momentum**

Unity Pro Small version 8.0 software packages (1) (2)

Description	License type	Reference	Weight kg/lb
Unity Pro Small software packages	Single (1 station)	UNYSPUSFUCD80	—
	Group (3 stations)	UNYSPUSFGCD80	—
	Team (10 stations)	UNYSPUSFTCD80	—
Software upgrades from: - Concept S - PL7 Micro - ProWORX NxT/32 Lite	Single (1 station)	UNYSPUSZUCD80	—
	Group (3 stations)	UNYSPUSZGCD80	—
	Team (10 stations)	UNYSPUSZTCD80	—

License type extensions for Unity Pro Small version 8.0

From	To	Reference	Weight kg/lb
Single (1 station)	Group (3 stations)	UNYSPUSZUGCD80	—
Group (3 stations)	Team (10 stations)	UNYSPUSZGTCD80	—

(1) Automatic renewals for Unity Pro new versions are possible during 1st year of subscription. Please contact our Customer Care Center for more information.
 (2) For compatibility of Unity software/automation platforms and distributed I/O, refer to the selection guide on page 4/2.

Software

Unity Pro software

Small/Large/Extra Large

Unity Pro Large version 8.0 software

For Modicon M340: **All models**
 For Modicon M580: **BMEP5810/5820/5830**
 For Modicon Premium: **TSX571●...4●**
 For Modicon Quantum: **140CPU31110/43412U/53414U**
 For distributed I/O: **Modicon ETB, TM7, OTB, STB, Momentum**

Unity Pro Large version 8.0 software packages (1) (2)

Description	License type	Reference	Weight kg/lb
Unity Pro Large software packages	Single (1 station)	UNYSPULFUCD80	–
	Group (3 stations)	UNYSPULFGCD80	–
	Team (10 stations)	UNYSPULFTCD80	–
	Facility (≤ 100 stations)	UNYSPULFFCD80	–
Software upgrades from: - Concept S, M - PL7 Micro, Junior, Pro - ProWORX NxT/32 Lite	Single (1 station)	UNYSPULZUCD80	–
	Group (3 stations)	UNYSPULZGCD80	–
	Team (10 stations)	UNYSPULZTCD80	–
	Facility (≤ 100 stations)	UNYSPULZFC80	–

License type extensions for Unity Pro Large version 8.0

From	To	Reference	Weight kg/lb
Single (1 station)	Group (3 stations)	UNYSPULZUGCD80	–
Group (3 stations)	Team (10 stations)	UNYSPULZGTC80	–

Upgrade to Unity Pro Large from Unity Pro Small

Type of upgrade The number of stations is unchanged	Reference	Weight kg/lb
Small to Large Single (1 station)	UNYSPULZSUCD80	–
Small to Large Group (3 stations)	UNYSPULZSGCD80	–
Small to Large Team (10 stations)	UNYSPULZSTCD80	–

Upgrade to Unity Pro Large from Unity Pro Medium

Type of upgrade The number of stations is unchanged	Reference	Weight kg/lb
Small to Large Single (1 station)	UNYSPULZMUCD80	–
Small to Large Group (3 stations)	UNYSPULZMGCD80	–
Small to Large Team (10 stations)	UNYSPULZMTC80	–

(1) For compatibility of Unity software/automation platforms and distributed I/O, refer to the selection guide on page 4/2.

(2) Automatic renewals for Unity Pro new versions are possible during 1st year of subscription. Please contact our Customer Care Center for more information.

Software

Unity Pro software

Small/Large/Extra Large



Unity Pro

4

Unity Pro Extra Large version 8.0 software

For Modicon M340: **All models**
 For Modicon M580: **All models**
 For Modicon Premium: **TSX571e...6e**
 For Modicon Quantum: **140CPU31110/43412U/53414U/65150/65160/65260/67160/67260/67261**
 For distributed I/O: **Modicon ETB, TM7, OTB, STB, Momentum**

Unity Pro Extra Large version 8.0 software packages (1) (2)

Description	License type	Reference	Weight kg/lb
Unity Pro Extra Large software packages	Single (1 station)	UNYSPUEFUCD80	–
	Group (3 stations)	UNYSPUEFGCD80	–
	Team (10 stations)	UNYSPUEFTCD80	–
	Facility (≤ 100 stations)	UNYSPUEFFCD80	–
Software upgrades from: - Concept S, XL - PL7 Micro, Junior, Pro - ProWORX NxT Lite, Full - ProWORX 32 Lite, Full	Single (1 station)	UNYSPUEZUCD80	–
	Group (3 stations)	UNYSPUEZGCD80	–
	Team (10 stations)	UNYSPUEZTCD80	–
	Facility (≤ 100 stations)	UNYSPUEZFC80	–

License type extensions for Unity Pro Extra Large

From	To	Reference	Weight kg/lb
Single (1 station)	Group (3 stations)	UNYSPUEZUGCD80	–
Group (3 stations)	Team (10 stations)	UNYSPUEZGTC80	–

Upgrade to Unity Pro Extra Large from Unity Pro Large

Type of upgrade	Reference	Weight kg/lb
The number of stations is unchanged		
Large to Pro Extra Large Single (1 station)	UNYSPUEZLUCD80	–
Large to Pro Extra Large Group (3 stations)	UNYSPUEZLGCD80	–
Large to Pro Extra Large Team (10 stations)	UNYSPUEZLTC80	–

Unity Pro Extra Large Educational version 8.0 software packages (1) (2)

Description	License type	Reference	Weight kg/lb
Unity Pro Educational software package	Facility (≤ 100 stations)	UNYSPUEEFCD80	–

(1) For compatibility of Unity software/automation platforms and distributed I/O, refer to Unity Pro Extra Large in the selection guide on page 4/3.

(2) Automatic renewals for Unity Pro new versions are possible during 1st year of subscription. Please contact our Customer Care Center for more information.



BMXXCAUSBH0●●



TSXPCX1031



TSXCUSB485



TCSWAAC13FB

Accessories for connecting to the PC programming terminal

Description	Use		Length m/ft	Reference	Weight kg/lb
	From processor port	To PC port			
PC terminal connection cables (PC to PLC) (1)	USB mini B port BMXP341000/20●0/20●02 BMEP58●●●●	USB port	1.8/ 5.91	BMXXCAUSBH018	0.065/ 0.143
	Mini-DIN port Premium TSX571●/2●/3●/4●	RS 232D (9-way SUB-D connector)	2.5/ 8.20	TSXPCX1031	0.170/ 0.375
		USB port (USB/ RS 485 converter)	0.4/ 1.31	TSXCUSB485 (2)	0.144/ 0.318
		USB port (mini-DIN/ RJ45 cordset)	2.5/ 8.20	TSXCRJMD25 (2)	0.150/ 0.331
	Modbus port 15-way SUB-D Quantum 140CPU31110 140CPU43412A 140CPU53414B	RS 232D (9-way SUB-D connector)	3.7/ 12.1 15/ 49.2	990NAA26320 990NAA26350	0.300/ 0.661 0.180/ 0.397
	USB port Premium TSX575●/6● Quantum 140CPU6●1	USB port	3.3/ 10.8	UNYXCAUSB033	–
	Modbus port, RJ45 connector Quantum 140CPU6●1	RJ 45 connector	1/ 3.28	110XCA28201	–
			3/ 9.84	110XCA28202	–
			6/ 19.7	110XCA28203	–
PC terminal connection cables (PC SUB-D to Modicon STB I/O)	HE13 connector Modicon STB I/O network interface module (NIM)	RS 232D (3) (9-way SUB-D connector)	2/ 6.56	STBXCA4002	0.210/ 0.463
USB/SUB-D adaptor (PC USB to Modicon STB I/O)	HE13 connector Modicon STB I/O network interface module (NIM) with Modicon STB STBXCA4002 cable (4)	USB port (4)	–	SR2CBL06	0.185/ 0.408

Description	Use	Reference	Weight kg/lb
Universal Bluetooth® interface (UBI)	<p>Provides Bluetooth® connectivity for products such as the Modicon M340/Premium platforms and Altivar/Lexium servo drives, via their serial port (RS 485).</p> <p>Used for setting-up and maintenance of products. Designed for permanent installation and can be fitted on the inside or outside of electrical enclosures.</p> <ul style="list-style-type: none"> ■ Protocols supported: Modbus and Uni-Telway ■ Powered via the product's RS 485 serial port ■ Max. range in direct line of sight: 20 m/65.6 ft <p>The kit comprises:</p> <ul style="list-style-type: none"> ■ A Universal Bluetooth® interface (UBI) ■ An RJ45/mini-DIN cable (length 1 m/3.28 ft) ■ An RJ45/RJ45 cable (length 1 m/3.28 ft) ■ A fixing clamp for installation inside the electrical enclosure ■ A CD with configuration software and user manual 	TCSWAAC13FB	0.320/ 0.705

(1) The **490NTW00002** and **490NTW00002U** RJ45 ConneXium cables (2 m/6.56 ft) can be used to connect the PC to the SERVICE port of M580 CPUs or X80 drop. Please consult our website www.schneider-electric.com.

(2) The **TSXCUSB485** converter requires use of the **TSXCRJMD25** mini-DIN/RJ45 cordset.

(3) Use the **SR2CBL06** cable for connection on a USB port (4).

(4) Adaptor equipped with a USB connector (PC side) and a 9-way SUB-D connector (STBXCA4002 cable side); requires the **STBXCA4002** cable (9-way SUB-D/HE 13) for connection to the HE13 connector on the Modicon STB NIM.



Unity EFB Toolkit

4

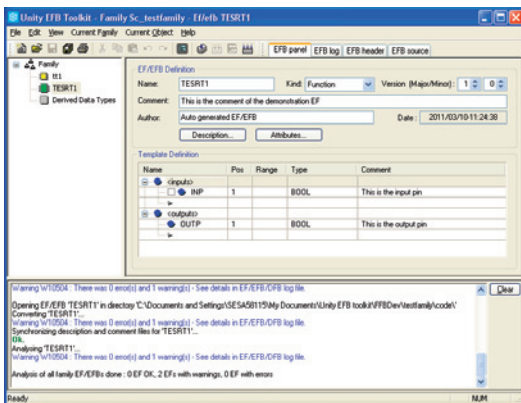

EFB Toolkit: Managing function block families

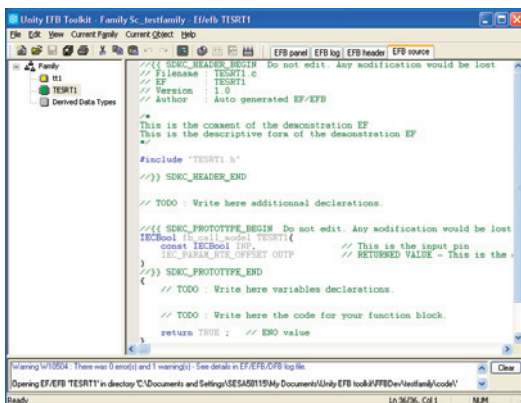

EFB Toolkit: Editor

Presentation

Unity EFB Toolkit is the software for developing EF and EFBs in "C" programming language. As an option with Unity Pro, it can be used to extend the standard Unity Pro function blocks in order to increase functionality. This software comes with *Microsoft Visual Studio*, which can be used to debug the function blocks developed in the Unity Pro PLC simulator. Unity EFB Toolkit also includes a service for creating and managing families of function blocks and integrating them in Unity Pro.

Setup

Unity EFB Toolkit manages the whole process of developing Unity Pro function blocks:

- User-friendly graphical user interface with automatic file organization
- Powerful tools for testing and debugging
- Management of compatibilities and software versions of created functions
- Generation of executable files for subsequent installation of functions on different Unity Pro stations

Managing function block families

The software can be used to create function block families. The function blocks developed, also known as EF/EFBs, are stored in families. This makes it possible to create an organized library of functions written in "C" language. Once created, these function block families are installed on the Unity Pro stations for the purpose of extending the standard Unity Pro libraries. Integration in Unity Pro can be executed from Unity EFB Toolkit or via the tool for updating Unity Pro libraries, which allows these families to be distributed without the use of any other software.

Developing function blocks

The EFB Toolkit software allows the user to create a function block as follows:

- Declaration of the function block interface in the same way as for the DFBS in Unity Pro
- Definition of all data types needed (elementary, structures, tables)
- Support of public and private variables
- Generation of all files and the block "C" coding frame (the user only adds functionality to this frame)
- Granting access to numerous internal PLC services, such as the real-time clock, PLC variables and data, system words and math functions, including high-precision numerical processing in "double" format
- Structure of the function block family (compilation/link for all Unity Pro automation platforms)
- Provision of a debugging environment: the function blocks created can easily be debugged in *Microsoft Visual Studio* by downloading a Unity Pro application containing the function developed in the Unity Pro PLC simulator. The debugging functions in *Microsoft Visual Studio*, especially breakpoints, step-by-step operations, display of the code/data and manipulation of the data, can be accessed without restriction.
- Support for managing Unity Pro versions, important during the function block maintenance phase

Note: GNU compiler is used to generate the code for a Modicon M340, M580 and Momentum platform. It is supplied with the Unity EFB Toolkit.

Compatibility

Unity EFB Toolkit is compatible with Unity Pro Small, Large and Extra Large. EFs and EFBs can be developed for Modicon Premium, Quantum, M340, M580 and Momentum platforms.

The latest available EFB Toolkit version is V8.0:

- OS compatibility Windows® 7 (32-bit, 64-bit) and Windows® XP.
- Minimum supported version of Unity Pro is V6.0 and above if installation is on the same system.
- The generated libraries can be installed on lower Unity Pro versions with different systems.

Software

Unity Pro software
Unity EFB Toolkit software

References

Unity EFB Toolkit and its documentation are supplied in electronic format on DVD-ROM in English.

EFB Toolkit package includes:

- Unity EFB Toolkit DVD
- GNU Compiler CD
- MS Visual Studio DVD

Description	Type	Language	Reference	Weight kg/lb
Unity EFB Toolkit software	Single license (1 station)	English (software and electronic documentation)	UNYSPUZFUCD80	–



Unity DIF

Presentation

Unity DIF is a companion software for Unity Pro. It compares two Unity Pro applications and displays an exhaustive list of the differences. The differences are displayed graphically and textually based on the type of program/section chosen. Unity DIF improves productivity during the main life stages of a control system, mainly during development and debugging of applications and commissioning, operation and maintenance of the installation.

Software setup

Unity DIF compares two Unity Pro application files (XEF, ZEF, STU and STA) and detects anything ADDED, DELETED and MODIFIED. The user interface and graphical representation of differences are similar to Unity Pro for consistency and ease of understanding the differences.

Unity DIF can be launched in several ways:

- From Unity Pro
- From the Windows Start menu
- From a command line interface

The user interface and graphical representation of differences are similar to Unity Pro graphics for consistency and ease of detecting the differences.

Unity DIF can provide differences for the following sections:

- PLC Configuration (Hardware and Network)
- Derived Data Types
- Derived FB Types
- Variables and FB Instance
- Motion
- Communication
- Programs
- Animation Table
- Operator Screen
- DTM Catalog
- Project Settings

The result of the comparison can be displayed in the user interface, printed or saved in .pdf and .txt file format.

Windows® OS Compatibility

Unity DIF V8.0 is compatible with Windows XP (32-bit), Windows 7 (32-bit and 64-bit), Windows 8 (32-bit and 64-bit) and Windows Server 2008 R2 (64-bit).

Comparison (1)

The base and compared files should be selected by the user, and the comparison results will be displayed with respect to the base file as reference.

Before initiating comparison, the user can select his preference of required section for comparison.

Displaying results

Upon comparison, the section summary will be loaded with the complete list. The user can navigate through the browser tree or using the F7 and F8 keys.

The differences will be highlighted in three different colors signifying Added, Deleted or Modified types. Colors can be customized as per the user's preference. The detailed report can be generated through Print or can be Saved for later reference.

Unity DIF also supports command line processing and .txt report generation for interfacing with Partner software.

(1) Comparison of STU and STA requires Unity Pro to be available.

4

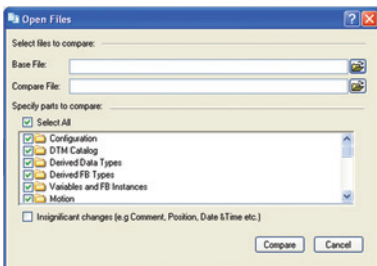

Selection of elements to compare

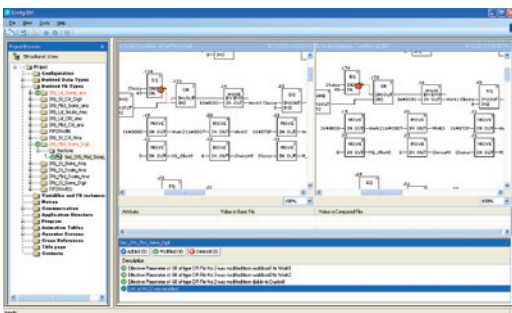

Displaying results

Software

Unity Pro software
Unity DIF software

References

This Unity DIF software is used to compare two Unity applications generated by Unity Pro software version V2.1 or later.

Compatibility: All Unity Pro packages and platforms are supported.

Description	Language	Type	Reference	Weight kg/lb
Unity DIF software	English (software and electronic documentation)	Single license (1 station)	UNYDFFXZZSPA80 (1)	–

(1) Available on our website www.schneider-electric.com.



Unity Loader

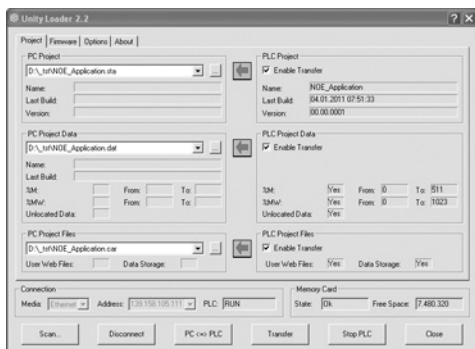

Unity Loader: Project tab

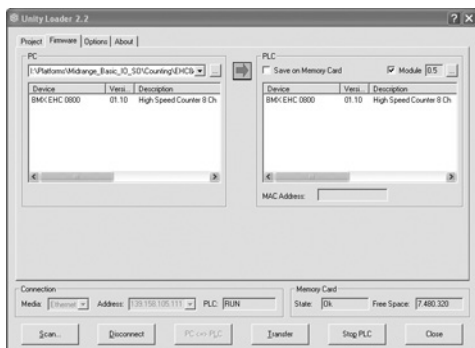

Unity Loader: Firmware tab

Presentation

Unity Loader is companion software to Unity Pro and is used to perform maintenance operations on automation applications. Its easy setup and the small size of its executable make it a vital tool for updating Unity Pro projects without needing to use Unity Pro. It can also be used for updating the embedded software on Modicon M340, M580 or Momentum Unity PLCs or on Modicon X80 I/O modules. It performs the following main functions:

- Transferring automation project components, such as the program and data, from the PC to the PLC or the PLC to the PC
- Transferring files and user Web pages stored in the memory card of Modicon M340 PLCs
- Transferring the firmware from the PC to Modicon M340, M580 or Momentum Unity PLCs or to Modicon X80 I/O modules

Software graphic interface

The interface is easy to use and has four tabs for access to different operations:

- The “**Project**” tab manages the transfer of projects (program and data) between the PC and the PLC CPU. The software transfers the program (application file format: .stu; archive file format: .sta) and data (located and unlocated; data file format: .dat) of a Unity Pro project in both directions. The program and data files created by Unity Loader are compatible with Unity Pro. When it is connected to the PLC, Unity Loader displays the information associated with the data read in the PLC. This information is displayed on the PC for the selected files. The user decides which project elements will be transferred by a single command after validation of the required transfers.
 - *Modicon M340 PLCs and BMXRMS●●8MFP memory card only:* the files and user Web pages can be transferred from the memory card to the PC and vice versa.
 - *BMXNOE0110 with flash memory card only:* Web pages stored in the flash memory can be transferred from the module to the PC and vice versa.
- The “**Firmware**” tab can be used to update the firmware in the Modicon M340, M580 or Momentum Unity PLCs or on Modicon X80 I/O modules. The screen displays the detailed content of the firmware versions existing in the module and on the PC. Firmware updating works in the same way as project transfers.
- The “**Options**” tabs is used to configure the working environment, especially the location of files on the PC and the selection of one of the six languages supported (English, French, German, Italian, Spanish and Chinese) for the user interface and online help.
- The “**About...**” tab displays information about the software.

Note: Regardless of which tab is selected, the connection status with the PLC is continuously displayed, together with commands for connection/disconnection and changing the PLC operating mode.

Modicon M340 PLC and BMXRMS●●8MFP memory card only

The Unity Loader software can download the project files and the firmware (PLC or module) onto a flash memory card (**BMXRMS●●8MFP** only) plugged into the PLC CPU. This firmware download can then be used to update a remote Modicon M340 PLC.

Automation of Unity Loader commands

Projects can be downloaded/uploaded between a PLC and a supervisory station equipped with Unity Loader software by means of a command file included in the supervisory application.

4



Unity Loader

Communication between the PC and the PLC

Unity Loader supports the following PC-to-PLC communication:

- Modicon Quantum Unity Pro PLCs: Modbus communication, transfer of project components only
- Modicon Premium Unity Pro PLCs: Unitelway communication, transfer of project components only
- Modicon M340, M580 or Momentum Unity PLCs or Modicon X80 I/O modules: communication via Ethernet and USB ports, transfer of project components and firmware. See the table below:

Reference	Type of module	Ethernet port	USB port
BMXP342000	M340 CPU with Modbus		
BMXP342010/20103	M340 CPU with CANopen		
BMXP342020	M340 CPU with integrated Ethernet port		
BMXP342030/20302	M340 CPU with integrated Ethernet port		
BMXNOE0100/0110	X80 module Ethernet Modbus/TCP		
BMXAMI/ART/AMO/AMM	X80 module Analog I/O		
BMXEHC0200/0800	X80 module Counter		
BMXMSP0200	X80 module Motion control		
BMEP58 10XX/20XX/30XX/40XX	M580 CPUs		
BMXNOC0402 (1)	M580 local communication module		
171CBU78090	Momentum Unity CPU with integrated port		
171CBU98090/ 171CBU98091	Momentum Unity CPU with integrated port		

 Supported Supported if CPU has integrated Ethernet port

For Ethernet networks, Unity Loader contains a network scanner which can be used to scan a range of network addresses. Once a recognized Modicon M340, M580 or Momentum Unity PLC has been selected, data transfer operations can be performed.

References

Unity Loader is supplied with Unity Pro Small, Large and Extra Large. It can also be downloaded free of charge from our website www.schneider-electric.com, download section.

Compatibility:

Unity Loader is independent of Unity Pro and compatible with Modicon M340, M580 or Momentum Unity PLCs, Unity Pro Quantum PLCs via Modbus and Unity Pro Premium PLC via Unitelway. The program files and PLC data files are compatible between Unity Pro and Unity Loader.

Description	Type	Reference	Weight kg/lb
Unity Loader software	Single license (1 station)	Software can be downloaded free of charge from our website www.schneider-electric.com	–

(1) The **BMXNOC0402** communication module will be replaced by the **BMENOC03•1** modules during the 2nd quarter of 2014.



Unity specific Libraries

4

Presentation

The CONT_CTL process control function block library supplied with Unity Pro software can be supplemented with optional specialized libraries so as to meet specific needs such as:

- Predictive control
- Fuzzy logic controller
- HVAC
- Mass flow calculation

Fuzzy Control Library

This library is used in particular in the water treatment field, for example for controlling chlorine levels in fresh water pools or controlling water levels in high-level reservoirs.

Flow Calculation Library

This library is used in the vertical Oil & Gas field, for measuring the gas flow in compliance with the *American Gas Association (AGA)* standard. This version of the library includes the AGA3, AGA7 and AGA8 function blocks.

TeSys Library

This library provides function blocks for TeSys T and TeSys U starter-controllers for M340 and Premium platforms. It includes function blocks and a help function for Unity Pro.

PCR Library for Unity Pro and Concept

This library is used for predictive control of process applications. Originally developed for reactors, predictive control can be used in other industrial sectors. Schneider Electric's *Companion Unity & Libraries* team works in partnership with the French company *Sherpa Engineering*, who specialize in predictive control consultancy services.

Heating Ventilation & Air Conditioning Library

This library is used in the HVAC field and deals with repetitive temperature control and humidity problems using ventilation equipment.

System Library for Unity Pro

This library offers functional blocks that are derived from Devices and Process Library but only has Unity Pro components (DFBs). The Devices and Process Library supports several Schneider Electric devices including TeSys T and TeSys U starters-controllers, Modicon STB distributed inputs/ outputs, power meters, Altivar variable speed drives, Icla and Lexium integrated drives, SEPAM digital protection relays, various fieldbus communications and other standard objects for motors. There are approximately 100 objects in the library.



Unity specific Libraries

Specific libraries depending on the software used

Specific libraries depending on the software used (see below) can be ordered separately.

Control libraries

Description	Target software	Type	Reference	Weight kg/lb
PCR Library	Unity Pro and Concept	Single license (1 station)	UNYLPCZAUWB	–
Fuzzy Control Library	Unity Pro	Single license (1 station)	UNYLFZZAUWB12	–
TeSys Library			UNYLTZSAUWB10	–
Heating Ventilation & Air Conditioning Library			UNYLHVZAUWB10	–
Flow Calculation Library			UNYLAGZAUWB20	–
System Library			UNYLSYSFU	–

System libraries for Unity Pro

Description	Target software	Type	Reference	Weight kg/lb
Enhanced Process Library (1)	UAG	Single license (1 station)	UAGSBTCFUCD10	–
Devices and Process Library (1)			UAGSBTDFUWB13	–

(1) Compatible with Unity Pro V5.0 max. For Unity Pro \geq V6.0, please consult our Customer Care Center.



OPC Factory Server



4

Presentation

Based on the OLE for Process Control (OPC) standard, Schneider Electric's OPC Factory Server (OFS) software allows "client" software applications, such as supervisors/SCADA and customized interfaces, to access the data of Schneider Electric automation system and electrical distribution devices connected to networks or fieldbuses in real time.

It also allows communication with third-party devices supporting Modbus and Modbus/TCP protocols.

OFS enables simpler, more open and transparent communication between your software applications and your devices. These are just some of the advantages that result in a complete interoperability solution that is central to your process.

In version V3.5, the OFS data server integrates the following specifications:

- **OPC-DA** (OPC Data Access)
- **.NET API interface**
- **OPC XML-DA V1.0** (OPC XML Data Access)
- **OPC-UA** (OPC Unified Architecture)

There are two versions of the OFS V3.5 offer:

- **OFS Small:** Data server for 1000 items (1) supporting the OPC-DA and OPC-UA protocols (OPC XML-DA protocol not supported).
- **OFS Large:** Data server with an unlimited number of items (1) supporting the OPC-DA, OPC XML-DA and OPC-UA protocols.

Devices and protocols supported

OFS software is a multi-device data server: it allows simultaneous use of several communication protocols, and it provides client applications with a set of services for accessing control system items that may be local or remote, via physical address or via symbol.

Devices supported:

- Modicon Quantum, Premium, M340, M580, Micro, Compact and Momentum PLCs
- Schneider Electric TSX Series 7 and April Series 1000 PLCs
- Modbus serial devices connected via Schneider Electric gateways: TSXETG10●●, EGX●●● ranges, etc.
- Uni-Telway serial devices connected via Schneider Electric gateways (TSXETG1010)

Networks and protocols supported:

- Modbus: Modbus serial, Modbus Plus, Modbus/TCP
- X-Way/Uni-TE: Uni-Telway, Fipway, ISAWay, PClway

Openness

The development of specialized interfaces is simpler with OFS V3.5 software, which is aimed at two types of user in particular:

■ **End users** who want either to interface their supervision or human/machine interface applications with Schneider Electric equipment, or to develop applications on a PC (supervisory control screens, Excel spreadsheets etc.) requiring access to control system data.

■ **Suppliers of control system or industrial data processing software** (supervision, human/machine interfaces, etc.) seeking to develop, within their standard products, an OPC Client interface capable of accessing data in Schneider Electric equipment via the OFS server.

(1) "item": variable, structure, table etc. in the Unity Pro application.



OPC Factory Server: Home page

Supported architectures

The OFS server allows four access modes:

- A purely local mode
- Remote access from an OPC-DA client
- Remote access from an OPC.NET client
- Remote access from an OPC XML-DA or OPC UA clients
- Remote access from an OPC-UA client

Local access

The client application and the OFS server are on the same PC.

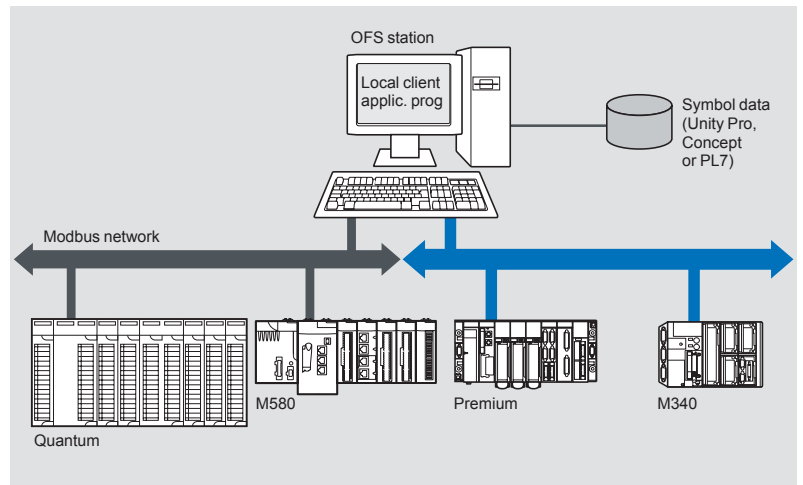

Remote access from an OPC-DA client

The client application and the OFS data server are on remote stations.

Communication between the client station and the OFS server is conducted through the DCOM layer (Microsoft) via the OPC-DA protocol.

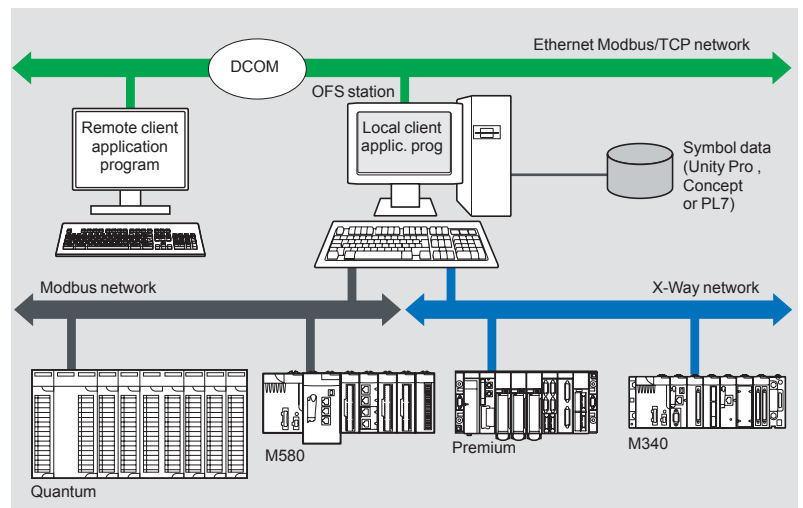

Architectures supported (continued)

Remote access from an OPC .NET client

The .NET client application program and the OFS data server are on remote stations. Communication between the client station and the OFS server is conducted through the DCOM layer (Microsoft) via the OPC-DA protocol.

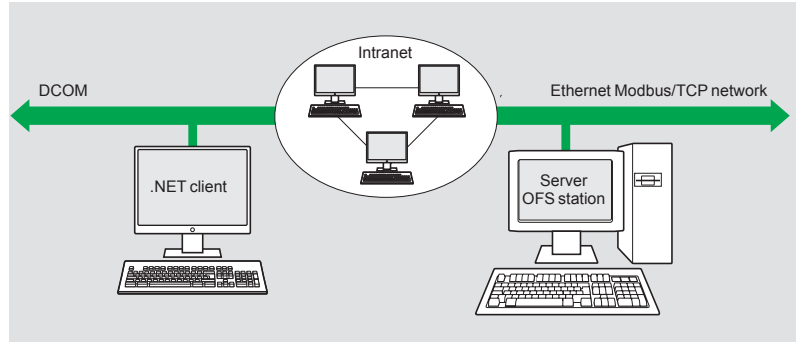

The .NET Microsoft compatibility of the OFS server has been developed to allow an OPC .NET client to access OFS server items on an Intranet network via the OPC .NET API interface.

This interface provides interoperability between existing OPC applications and applications developed in the standard .NET environment.

Remote access from an OPC XML-DA client via HTTP

The client application program and the OFS server are on remote stations, using the SOAP protocol to communicate via the Internet in conformity with the OPC XML-DA or OPC UA specification of the OPC Foundation.

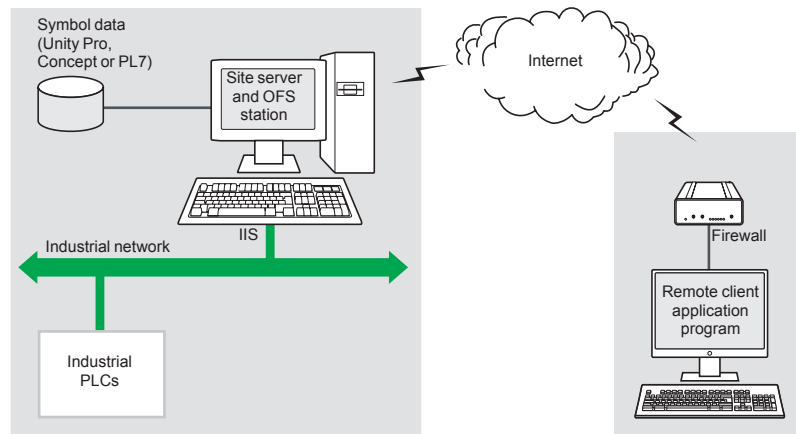

These two protocols are designed to overcome the limitations of COM/DCOM, thus providing:

- A standardized interface for Windows and non-Windows client applications
- Beyond the Intranet perimeter, remote access via the Internet through firewalls

The OPC XML-DA specification is based on Web Services standards such as SOAP, XML and WSDL (1). A SOAP client can access data on the OFS server via Intranet or Internet using the SOAP protocol in conformity with the OPC XML-DA or OPC UA specification of the OPC Foundation.

(1) SOAP: Simple Object Access Protocol
 XML: Extensible Markup Language
 WSDL: Web Services Description Language

Setup

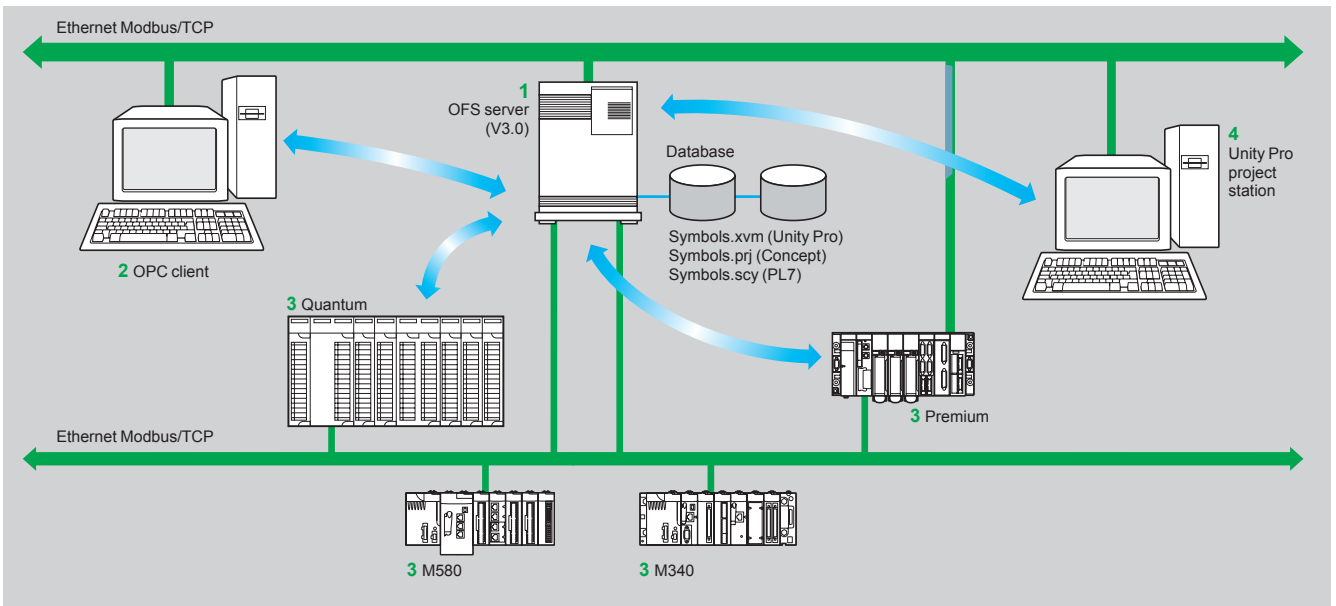

The OFS server **1** is at the center of the data exchanges. It makes variables exchanged between the OPC client **2** and the PLC **3**, consistent in one of three ways, using a symbol (or variables) database:

- The variables database is either the Unity Pro project **4**, or the Concept project. In both these cases, Unity Pro or Concept needs to be installed on the OFS server station.
- Or the variables database is an export file (SCY for PL7, XVM for Unity Pro). PL7 and Unity Pro are not required in either of these cases.
- Or the variables database is the PLC itself. In this case neither Unity Pro nor an export file is needed. This does not apply to Momentum and TSX Micro PLCs. If an inconsistency is detected (following online modification of the PLC program for example), OFS resynchronizes itself automatically as a background task, without breaking communication between the PLC and the OPC client. For this function the following minimum versions are required:
 - OFS V3.35
 - Unity Pro V6.0
 - Modicon M340 V2.3, M580 V1.0, Premium V2.9 and Quantum V3.0 PLCs

Function

Development of client applications

OFS software has 4 types of interface:

■ **OLE Automation interface (OPC-DA)**

Particularly suitable for end users, this enables the development of OPC client applications in Visual Basic, in Visual Basic for Excel, and in C++.

■ **OLE Custom interface (OPC-DA)**

Used primarily by suppliers of automated control system or industrial IT products, this interface enables the development of applications in C++ in order to access the OFS software OPC server. It is aimed at software development experts in particular, so that they can integrate the client application into their standard products. It is the interface with the highest performance, in terms of access time to data stored in the OPC server. It requires extensive knowledge of C++ programming to set up.

■ **OPC .NET API wrapper interface**

The .NET Microsoft compatibility of the OFS data server gives an OPC .NET client standard access to OFS server items via an Intranet network, thus providing greater interoperability with standard .NET environments.

Note: In this case, communication between the OPC .NET client and the OFS server is conducted through the DCOM layer (or COM layer in a local configuration) via the OPC-DA protocol.

■ **OPC XML-DA interface (1)**

The OPC XML-DA V1.0 specifications are designed to overcome the limitations of the OPC-DA specification and COM/DCOM by providing:

- An interface for Windows and non-Windows client applications
- Remote access via the Internet through firewalls (beyond the Intranet perimeter)

The OPC XML-DA specification is based on Web Services standards such as SOAP, XML, WSDL. A SOAP client can access data on the OFS server via Intranet or Internet using the SOAP protocol in conformity with the OPC XML-DA V1.01 specification of the OPC Foundation.

■ **The OPC-UA interface**

This interface is aimed at users with software that includes an OPC-UA client interface. This interface is based on the same communication standards as the OPC XML-DA interface and offers the same advantages as it, which are:

- An interface with Windows and non-Windows applications
- Remote access, via the Internet, through a firewall

(1) Available only with the Large version of OPC Factory Server.



OPC Factory Server

References

OFS V3.5 software for PC compatible stations (minimum configuration: Pentium 566 MHz processor, 128 Mb of RAM) running Windows® 7 (32-bit or 64-bit) or Windows 8 (32-bit or 64-bit).

The OFS V3.5 offer comprises:

- OPC server software
- OPC server simulator (for debugging the application when no PLCs are present)
- OFS server configuration software
- An example of OPC client for setting up applications
- The setup documentation on DVD-ROM
- A reference document on “time stamping system” solutions
- A tool to help with sizing and configuring “time stamping system” solutions

Supplied on DVD-ROM, the software operates independently on a PC. It interfaces with the variable export files generated by PL7, ProWORX, Concept, and Unity Pro software.

It also provides a direct dynamic link to the Unity Pro and Concept applications.

OFS V3.5 software is available in two versions:

■ **Small Version TLXCDS•OFS35**

- Maximum of 1000 items (1)
- Protocols supported: OPC-DA and OPC-UA
- Single station and 10-station site licenses

■ **Large Version TLXCDL•OFS35**

- Unlimited number of items (1)
- Protocols supported: OPC-DA, OPC XML-DA and OPC-UA
- Single station, 10-station and 200-station site licenses

OPC Factory Server V3.5 Small

Description	License type	Reference	Weight kg/lb
OPC Factory Server V3.5 Small software ■ Maximum of 1000 items (1) ■ Protocols supported: OPC-DA and OPC-UA	Single station	TLXCDSUOFS35	–
	10 stations	TLXCDSSTOFS35	–

OPC Factory Server V3.5 Large

Description	License type	Reference	Weight kg/lb
OPC Factory Server V3.5 Large software ■ Unlimited number of items (1) ■ Protocols supported: OPC-DA, OPC XML-DA and OPC-UA	Single station	TLXCDLUOFS35	–
	10 stations	TLXCDLTOFS35	–
	200 stations	TLXCDLFOFS35	–

(1) “item”: variable, structure, table etc. in the Unity Pro application.

Presentation

The time stamping system is a complete solution providing a SCADA with a sequence of events that are time-stamped at source, enabling the user to analyze the source of any abnormal behavior in an automated system.

The SOE (sequence of events) is displayed in the alarm log or in the list of events for a client such as a SCADA.

Each event in the SOE is a change of value (transition) of a discrete I/O detected by a time stamping module.

Advantages

Using the time stamping system has the following advantages:

- No PLC programming
- Direct communication between the time stamping modules and the client. If the time stamping modules are in a Quantum Ethernet I/O drop, the bandwidth of the PLC communication is not used
- Consistency of the I/O values between the process (time stamping modules) and the client
- Consistency is maintained irrespective of the operating mode
- No loss of events under normal operating conditions
- Management of Hot Standby configurations on the PLC and/or SCADA redundancy

Composition of a time stamping architecture

BMXCRA31210 and BMECRA31210 modules

This time stamping module can be at the source of any discrete I/O signal located in the drop with a resolution of 10 ms.

To avoid losing any events, all events are stored and kept in a buffer located in the product until OFS takes them.

Synchronization of the CRA module uses the NTP protocol.

BMXERT1604T module

This module has 16 discrete inputs which carry out the time stamping at source outputs with a resolution of 1 ms.

To avoid losing any events, all events are stored and kept in a buffer located in the product until OFS takes them.

This module can be placed either in an RIO drop, or in a local rack equipped with a BM•CRA31210 module.

The CRA module is synchronized via the DCF 77 or IRIG-B standards.

OFS V3.50

OFS V3.50 is used to access events stored in the various buffers in the architecture and to notify the SCADA of them via the standard OPC DA protocol.

Vijeo Citect V7.30

Vijeo Citect V7.30 receives events transmitted by OFS and displays them in the SOE or in the list of alarms.

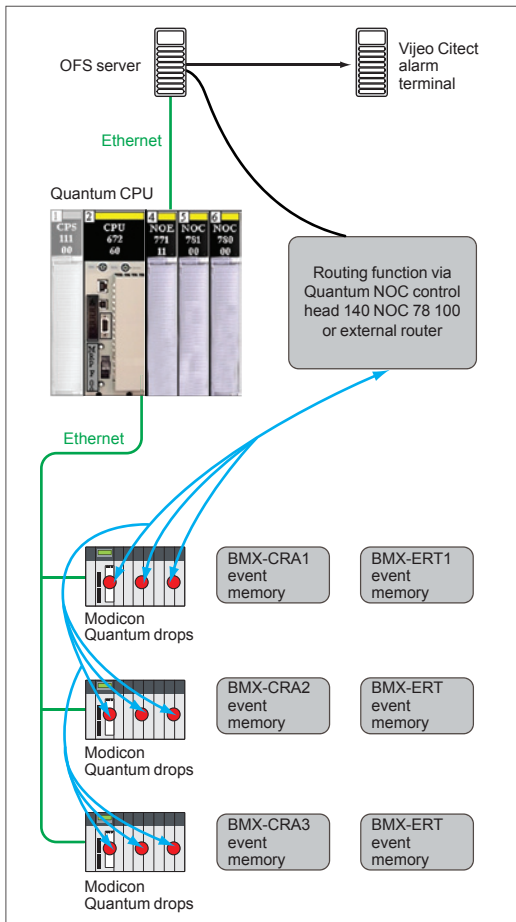

Example of a Time stamping architecture

Performance		
Performance	Event source module	Value
Between two identical source modules in the same rack	BMXERT1604T	1.6 < resolution < 3.3 ms
	BM•CRA31210	10 ms
Between two different inputs in the same source module	BMXERT1604T	1 ms
	BM•CRA31210	1 scan
Maximum number of events scanned	BMXERT1604T	400 events (1)
	BM•CRA31210	2048 events (1)
Maximum number of I/O and memory available	BMXERT1604T	16 discrete inputs on module 512 events in internal buffer
	BM•CRA31210	256 discrete I/O configured 4000 events in internal buffer
Maximum number of source modules in an Ethernet remote drop	BM•CRA31210	1 per drop
	BMXERT●●●●	9 per drop
Maximum number of event sources controlled	BMXERT●●●●	500 sources per second (1)

(1) This maximum value is not an absolute value. It depends on the overall system dynamics (total number of scanned items and number of events generated by the system).

5 - Ruggedized Modicon M580 modules

Treatment for severe environnements

- Presentation..... page 5/2
- Harsh chemical environnements page 5/2
- Extreme climatic environnements page 5/2

Ruggedized processor modules

- References page 5/3

Ruggedized racks and rack expansion module

- References page 5/4

Ruggedized communication module and network gateway

- References page 5/5

Presentation

Protective treatment of Modicon M580 automation platform

The Modicon M580 automation platform complies with “TC” treatment requirements (Treatment for all Climates). It is designed as standard to operate in temperatures of 0 to +60°C/32 to 140°F.

For installations in industrial production workshops or environments corresponding to “TH” (Treatment for Hot and humid environments), devices should be housed in enclosures providing at least IP 54 protection as specified by standard IEC/EN 60529, or an equivalent level of protection according to NEMA 250.

The Modicon M580 automation platform offers **IP 20 degree of protection** (1). It can therefore be installed without an enclosure in restricted access areas that do not exceed **pollution level 2** (control room with no dust-producing machinery or activity). **Pollution level 2** does not take account of harsher environments, such as those where the air is polluted with dust, fumes, corrosive or radioactive particles, vapors or salts, molds, insects, etc.

Treatment for more severe environments

If the Modicon M580 automation platform has to be used in more severe environments or is required to start and operate in an extended temperature range, from **-25°C to +70°C/-13°F to 158°F**, the “ruggedized” offer features industrially hardened processor modules, X-bus and X-bus + Ethernet racks, rack expansion modules and communication modules that have a protective coating on their circuit boards.

Note: Capable of starting within an extended temperature range (from -25°C to +70°C/-13°F to 158°F, a single-rack configuration is also able to operate at extremely low temperatures (to -40°C/-40°F) if placed in an appropriate enclosure. Please consult our Customer Care Center.

This treatment increases the isolation capability of the circuit boards and their resistance to:

- Condensation
- Dusty atmospheres (conducting foreign particles)
- Chemical corrosion, in particular during use in sulphurous atmospheres (oil refinery, purification plant, etc.) or atmospheres containing halogens (chlorine, etc.)

This protection, combined with appropriate installation and maintenance, enables Modicon M580 automation products to be used in the following environments:

Harsh chemical environments:

- **IEC/EN 60721-3-3 class 3C3:**
 - 14 days; 25°C/77°F relative humidity 75%
 - Concentrations (mm³/m³): H₂S: 2100/SO₂: 1850/Cl₂: 100
- **ISA S71.04 classes G1 to G3:**
 - 14 days; 25°C/77°F relative humidity 75%
 - Concentrations (mm³/m³): H₂S: 50/SO₂: 300/Cl₂: 10/NO₂: 1250
- **IEC/EN 60068-2-52 salt mist, Kb test severity level 2:**
 - 3 x 24-hour cycles
 - 5% NaCl
 - 40°C/104°F relative humidity 93%

Extreme climatic environments:

- Temperatures from -25 to +70°C/-13 to 158°F
- Relative humidity levels:
 - up to 93% from -25°C/-13°F to +60°C/140°F
 - up to 95% from -25°C/-13°F to +55°C/131°F
- Formation of ice
- Altitudes from 0 to 5,000 m/0 to 16,404 ft

(1) Each slot in a **BMXXBP0●00H**, **BMEXP0●00H** or **BMXXBE1000H** rack is equipped as standard with a protective cover that should only be removed when inserting a module. If any covers are subsequently misplaced, replacements can be ordered under reference **BMXXEM010** (sold in lots of 5).

Composition

References and characteristics

To order ruggedized modules and racks, see the reference pages 5/3 to 5/5 (the references of the ruggedized products available include the suffix "H").
The standard separate parts (cordsets, cables, sub-bases, etc.) that are compatible with the ruggedized modules offer are listed in the reference pages (see pages 5/3 to 5/5).
The majority of operating and electrical characteristics of ruggedized modules are identical to those of their equivalent standard versions. However, some characteristics are subject to either derating or limitation. Please consult our website www.schneider-electric.com.

Ruggedized Modicon M580 processors

Ruggedized Modicon M580 processors

I/O capacity	Maximum number of networks	Device ports	Service port	Reference	Weight kg/lb
1,024 discrete I/O, 256 analog I/O 24 application-specific channels 4 MB integrated (memory program)	2 Ethernet networks	2 DIO	1	BMEP581020H	–
2,048 discrete I/O, 512 analog I/O 32 application-specific channels 8 MB integrated (memory program)	2 Ethernet networks	2 DIO	1	BMEP582020H	–
		2 RIO/DIO	1	BMEP582040H	–



PF122552

BMEP58●●●●H

Standard SD Memory card

Description	Processor compatibility	Capacity	Reference	Weight kg/lb
SD memory card (optional)	Any processor	4 GB (for application backup and data storage)	BMXRMS004GPF	0.002/ 0.004



PF106120

BMXRMS004GPF

Standard separate parts

Description	Use		Length m/ft.	Reference	Weight kg/lb
	From	To			
Terminal port/ USB cordsets	Mini-B USB port on the Modicon M580 processor	Type A USB port on: PC terminal, Magelis HMI graphic terminal	1.8/5.905	BMXXCAUSBH018	0.065/ 0.143
			4.5/14.764	BMXXCAUSBH045	0.110/ 0.243



PF106185

BMXXCAUSBH●●

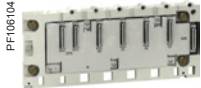

BMXXBP0400H

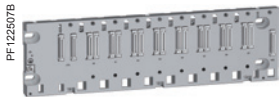

BMEXBP0800H



BMXXBE1000H



BMXXSP000
+ BMXXSP300



Angled connector on
extension cordsets

Ruggedized racks

Description	Type of module to be inserted	No. of slots (1)	Power consumption (2)	Reference	Weight kg/lb
Ruggedized X-bus racks	BMEP58 processor, BMXCPS power supply, I/O modules and application-specific (counter and communication) modules	4	1 W	BMXXBP0400H	0.630/ 1.389
		6	1.5 W	BMXXBP0600H	0.790/ 1.742
		8	2 W	BMXXBP0800H	0.950/ 2.094
		12	–	BMXXBP1200H	1.270/ 2.800
Ruggedized Ethernet + X-bus racks	BMEP58 processor, BMXCPS power supply, I/O modules and application-specific (counter and communication) modules	4	2.8 W	BMEXBP0400H	0.715/ 1.576
		8	3.9 W	BMEXBP0800H	1.070/ 2.359
		12	3.9 W	BMEXBP1200H	1.387/ 3.058

Ruggedized expansion module

Description	Use	Reference	Weight kg/lb
Ruggedized expansion module for ruggedized rack (3)	Standard module to be installed in each rack (XBE slot) Used to daisy-chain up to 4 racks	BMXXBE1000H	0.178/ 0.392

Standard accessories for racks

Description	For use with	Sold in lots of	Reference	Weight kg/lb
Shielding connection kits comprising: - a metal bar - 2 support bases	BM●XBP0400H rack	–	BMXXSP0400	0.280/ 0.617
	BMXXBP0600H rack	–	BMXXSP0600	0.310/ 0.683
	BM●XBP0800H rack	–	BMXXSP0800	0.340/ 0.750
	BM●XBP1200H rack	–	BMXXSP1200	0.400/ 0.882
Spring clamping rings	Cables, cross-section 1.5...6 mm ² /AWG 16...9	10	STBXSP3010	0.050/ 0.110
	Cables, cross-section 5...11 mm ² /AWG 10...7	10	STBXSP3020	0.070/ 0.154
Protective covers (replacement parts)	Unoccupied slots on BM●XBP●●00H rack	5	BMXXEM010	0.005/ 0.011

Standard cordsets and connection accessories

Description	Use	Composition	Type of connector	Length	Reference	Weight kg/lb			
X-bus extension cordsets total length 30 m/ 98.425 ft max. (3)	Between two BMXXBE1000H rack expansion modules	2 x 9-way SUB-D connectors	Angled	0.8 m/ 2.625 ft	BMXXBC008K	0.165/ 0.364			
				1.5 m/ 4.921 ft	BMXXBC015K	0.250/ 0.551			
				3 m/ 9.843 ft	BMXXBC030K	0.420/ 0.926			
				5 m/ 16.404 ft	BMXXBC050K	0.650/ 1.433			
				12 m/ 39.370 ft	BMXXBC120K	1.440/ 3.175			
				Straight	1 m/ 3.281 ft	TSXCBY010K	0.160/ 0.353		
					3 m/ 9.843 ft	TSXCBY030K	0.260/ 0.573		
			5 m/ 16.404 ft		TSXCBY050K	0.360/ 0.794			
			12 m/ 39.370 ft		TSXCBY120K	1.260/ 2.778			
			18 m/ 59.055 ft		TSXCBY180K	1.860/ 4.101			
			28 m/ 91.864 ft		TSXCBY280KT	2.860/ 6.305			
			(4)						
			Cable reel (3)	Length of cable to be fitted with TSXCBYK9 connectors	Ends with flying leads, 2 line testers		100 m/ 328.084 ft	TSXCBY1000	12.320/ 27.161

Nota: For other ruggedized modules in the Modicon X80 range, please consult the "Modicon X80 I/O platform" catalogue.
 (1) Number of slots taking the processor module, I/O modules and application-specific modules (excluding power supply module).
 (2) Power consumption of anti-condensation resistor(s).
 (3) Module and cordsets do not operate properly at temperatures lower than - 25°C/- 13°F.
 (4) Cable supplied with a set of 2 TSXTVSY100 electrical transient suppressors.

PF108138



TSXTLYEX

Connection accessories				
Description	Use	Composition	Reference	Weight kg/lb
Line terminator (Sold in lots of 2)	Required on both BMEXBP/ BMXXBP●●●0H modules at each end of the daisy chain	2 x 9-way SUB-D connectors marked A/ and /B	TSXTLYEX	0.050/ 0.110
X-bus straight connectors (Sold in lots of 2)	For ends of TSXCBY1000 cables	2 x 9-way SUB-D straight connectors	TSXCBYK9	0.080/ 0.176
Connector assembly kit	Fitting TSXCBYK9 connectors	2 crimping pliers, 1 pen (1)	TSXCBYACC10	–

PF122604B



BMECRA31210C

Communication				
"Conformal Coating" EIO drop adapter				
Description	SERVICE port		Reference	Weight kg/lb
Modicon X80 EIO drop adapter for Ethernet + X-bus racks	1		BMECRA31210C	–

PF516164



TCSEGPA23F14FK

Ruggedized Profibus DP network gateway				
Description	Protocols	Physical layer	Reference	Weight kg/lb
Profibus Remote Master (PRM) module	Modbus TCP	1 Ethernet switch, 2 x 10BASE-T/100BASE-TX ports	TCSEGPA23F14FK	–
	Profibus DP V1 and Profibus PA (via gateway)	1 isolated RS 485 Profibus DP port		

Standard connection accessory				
Description	Details	RS 232 interface	Reference	Weight kg/lb
Cordset for DCE terminal (modem, etc.)	Equipped with 1 x RJ45 connector and 1 x 9-way male SUB-D connector Length 3 m/9.843 ft	Simplified 4-wire (RX, TX, RTS and CTS)	TCSMCN3M4M3S2	0.150/ 0.331
		Full 8-wire (except RI signal)	TCSXCN3M4F3S4	0.165/ 0.364

(1) To fit the connectors on the cable, you also need a wire stripper, a pair of scissors and a digital ohmmeter.

Technical appendices

- Standards, certifications and environmental conditions page 6/2
- Certifications for automation products and EC regulations page 6/6

Modicon M580 automation platform

Standards, certifications and environment conditions

Standards and certifications

The Modicon M580 automation platform has been developed to comply with the principal national and international standards concerning electronic equipment for industrial automation systems.

- Requirements specific to programmable controllers: functional characteristics, immunity, resistance, safety, etc.: **IEC/EN 61131-2**, UL and CSA standards for industry (**UL 508**, **CSA E61131-2**).
- Requirements specific to power utility automation systems: **IEC/EN 61850-3**.
- Merchant navy requirements of the major international organizations: unified in IACS (International Association of Classification Societies).
- Compliance with European Directives for CE marking:
 - Low Voltage: 2006/95/EC
 - Electromagnetic Compatibility: 2004/108/EC
- Ex areas:
 - For USA and Canada: Hazardous location class I, division 2, groups A,B,C and D
 - For other countries: CE ATEX (directive 94/9/EC) or IECEx in defined atmosphere Zone 2 (gas) and/or Zone 22 (dust).
 - Up-to-date information on which certifications have been obtained is available on our website.

Characteristics

Service conditions and recommendations relating to the environment

		Modicon M580 automation platform			Modicon M580 harsh automation platform		
Temperature	Operation	°C	0...+ 60			- 25...+ 70	
	Storage	°C	- 40...+ 85			- 40...+ 85	
Relative humidity (without condensation)	Cyclical humidity	%	+ 5 ... + 95 up to 55°C			+ 5 ... + 95 up to 55°C	
	Continuous humidity	%	+ 5 ... + 93 up to 55°C			+ 5 ... + 93 up to 60°C	
Altitude	Operation	m	0...2000 (full specification: temperature and isolation) 2000 ... 5000 (temperature derating: 1°C/400 m, isolation lost: 150 V ÷/1000 m)				
Supply voltage	Modicon X80 I/O power supply modules						
			BMXCPS2010	BMXCPS3020 BMXCPS3020H	BMXCPS3540T	BMXCPS2000	BMXCPS3500 BMXCPS3500H
	Nominal voltage	V	24 ---	24...48 ---	125 ---	100...240 ~	100...240 ~
	Limit voltages	V	18...31.2 ---	18...62.4 ---	100...150 ---	85...264 ~	85...264 ~
	Nominal frequencies	Hz	–	–	–	50/60	50/60
Limit frequencies	Hz	–	–	–	47/63	47/63	

Protective treatment of the Modicon M580 automation platform

The Modicon M580 platform meets the requirements of "TC" treatment (*Treatment for all Climates*).

For installations in industrial production workshops or environments corresponding to "TH" treatment (*treatment for hot and humid environments*), Modicon M580 must be embedded in enclosures with minimum IP 54 protection.

The Modicon M580 automation platform offers **protection to IP 20 level** and **protection against pins** (enclosed equipment) (1). They can therefore be installed without an enclosure in reserved-access areas which do not exceed **pollution level 2** (control room with no dust-producing machine or activity). Pollution level 2 does not take account of more severe environmental conditions: air pollution by dust, smoke, corrosive or radioactive particles, vapors or salts, attack by fungi, insects, etc.

(1) In cases where a position is not occupied by a module, a **BMXXEM010** protective cover must be installed.

(CE): tests required by European directives (CE) and based on IEC/EN 61131-2 standards.

Environment tests		
Name of test	Standards	Levels
Immunity to LF interference (CE) (1)		
Voltage and frequency variations	IEC/EN 61131-2; IEC/EN 61000-6-2; IEC 61000-4-11 IACS E10; IEC 61000-4-11	0.85...1.10 Un - 0.94...1.04 Fn; 4 steps t = 30 min 0.80 Un...0.90 Fn; 1.20 Un...1.10 Fn; t = 1.5 s/5 s
Direct voltage variations	IEC/EN 61131-2; IEC 61000-4-29; IACS E10 (PLC not connected to charging battery)	0.85...1.2 Un + ripple: 5% peak; 2 steps t = 30 min
Third Harmonic	IEC/EN 61131-2	H3 (10% Un), 0°/180°; 2 steps t = 5 min
Immunity to conducted low frequency (only IACS) IACS E10		For ~ : ■ H2...H15 (10% Un), H15...H100 (10%...1% Un), H100...H200 (1% Un) For --- : ■ H2...H200 (10% Un)
Voltage interruptions	IEC/EN 61131-2; IEC/EN 61000-6-2; IEC 61000-4-11; IEC 61000-4-29; IACS E10	Power supply immunity: ■ 1 ms for --- PS1/10 ms for ~ PS2 ■ Check operating mode for longer interruptions For IACS: ■ 30 s for ~ or ---
	IEC/EN 61131-2; IEC/EN 61000-6-2; IEC 61000-4-11	For ~ PS2: ■ 20% Un, t0: ½ period ■ 40% Un, cycle 10/12 ■ 70% Un, cycle 25/30 ■ 0% Un, cycle 250/300
Voltage shut-down and start-up	IEC/EN 61131-2	■ Un...0...Un; t = Un/60 s ■ Umin...0...Umin; t = Umin/5 s ■ Umin...0.9 Udl...Umin; t = Umin/60 s
Magnetic field	IEC/EN 61131-2; IEC/TS 61000-6-5; IEC 61000-4-8 (for MV power stations: IEC 61850-3)	Power frequency: 50/60 Hz, 100 A/m continuous ...1000 A/m; t = 3 s; 3 axes
	IEC 61000-4-10 (for MV power stations: IEC 61850-3)	Oscillatory: 100 kHz...1 MHz, 100 A/m; t = 9 s; 3 axes
Conducted common mode disturbances range 0 Hz ...150 kHz	IEC 61000-4-16 (for MV power stations: IEC 61850-3)	For remote systems: ■ 50/60 Hz and ---, 300 V, t = 1 s ■ 50/60 Hz and ---, 30 V, t = 1 min ■ 5 Hz...150 kHz, sweep 3 V...30 V

Where:

- PS1 applies to PLC supplied by battery, PS2 applies to PLC energized from ~ or --- supplies
- Un: nominal voltage, Fn: nominal frequency, Udl: detection level when powered

Name of test	Standards	Levels
Immunity to LF interference (CE) (1)		
Electrostatic discharges	IEC/EN 61131-2; IEC/EN 61000-6-2; IEC 61000-4-2; IACS E10	6 kV contact; 8 kV air; 6 kV indirect contact
Radiated radio frequency electromagnetic field	IEC/EN 61131-2; IEC/EN 61000-6-2; IEC 61000-4-3; IACS E10	15 V/m, 80 MHz ... 3 GHz Sinus amplitude modulated 80%, 1 kHz + internal clock frequencies
Electrical fast transient bursts	IEC/EN 61131-2; IEC/EN 61000-6-2; IEC 61000-4-4; IACS E10	For ~ or --- main supplies: ■ 2 kV in common mode/2 kV in wire mode For ~ or --- auxiliary supplies, ~ unshielded I/O: ■ 2 kV in common mode For analog, --- unshielded I/O, communication and shielded lines: ■ 1 kV in common mode
Surge	IEC/EN 61131-2; IEC/EN 61000-6-2; IEC 61000-4-5; IACS E10	For ~/--- main and auxiliary supplies, ~ unshielded I/O: ■ 2 kV in common mode/1 kV in differential mode For analog, --- unshielded I/O: ■ 0.5 kV in common mode/0.5 kV in differential mode For communication and shielded lines: ■ 1 kV in common mode
Conducted disturbances induced by radiated electromagnetic fields	IEC/EN 61131-2; IEC/EN 61000-6-2; IEC 61000-4-6; IACS E10	10 V; 0.15 MHz...80 MHz Sinus amplitude 80%, 1 kHz + spot frequencies
Damped oscillatory wave	IEC/EN 61131-2; IEC 61000-4-18; IACS E10	For ~/--- main supplies and ~ auxiliary supplies, ~ unshielded I/O: ■ 2.5 kV in common mode/1 kV in differential mode For --- auxiliary supplies, analog, --- unshielded I/O: ■ 1 kV in common mode/0.5 kV in differential mode For communication and shielded lines: ■ 0.5 kV in common mode

(1) Devices must be installed, wired and maintained in accordance with the instructions provided in the manual "Grounding and Electromagnetic Compatibility of PLC Systems".

(2) These tests are performed without an enclosure, with devices fixed on a metal grid and wired as per the recommendations in the manual "Grounding and Electromagnetic Compatibility of PLC systems".

(CE): tests required by European CE directives and based on IEC/EN 61131-2.

Environment tests (continued)		
Name of test	Standards	Levels
Electromagnetic emissions (CE) (1)		
Conducted emission	IEC/EN 61131-2; FCC part 15; IEC/EN 61000-6-4; CISPR 11 & 22, Class A, Group 1	150 kHz ... 500 kHz: quasi-peak 79 dB (µV/m); average 66 dB (µV/m) 500 kHz ... 30 MHz: quasi-peak 73 dB (µV/m); average 60 dB (µV/m)
	IACS E10	<ul style="list-style-type: none"> ■ ~ power (general power distribution zone): 10 kHz ... 150 kHz: quasi-peak 120...69 dB (µV/m); 150 kHz ... 0.5 MHz: quasi-peak 79 dB (µV/m) 0.5 MHz ... 30 MHz: quasi-peak 73 dB (µV/m) ■ ~ power (bridge and deck zone for evaluation): 10 kHz ... 150 kHz: quasi-peak 96...50 dB (µV/m) 150 kHz ... 0.35 MHz: quasi-peak 60...50 dB (µV/m) 0.35 MHz ... 30 MHz: quasi-peak 50 dB (µV/m)
Radiated emission	IEC/EN 61131-2; FCC part 15; IEC/EN 61000-6-4; CISPR 11 & 22, Class A, Group 1	30 MHz ... 230 MHz: quasi-peak 40 dB (µV/m) (at 10 m); 50 dB (µV/m) (at 3 m) 230 MHz ... 1 GHz: quasi-peak 47 dB (µV/m) (at 10 m); 57 dB (µV/m) (at 3 m)
	IACS E10	<ul style="list-style-type: none"> ■ For general power distribution zone 0.15 MHz ... 30 MHz: quasi-peak 80...50 dB (µV/m) (at 3 m) 30 MHz-100 MHz: quasi-peak 60...54 dB (µV/m) (at 3 m) 100 MHz - 2 GHz: quasi-peak 54 dB (µV/m) (at 3 m) 156 ... 165 MHz: quasi-peak 24 dB (µV/m) (at 3 m)

Name of test	Standards	Levels
Immunity to climatic variations (1) (power on)		
Dry heat	IEC 60068-2-2 (Bb & Bd)	60°C, t = 16 hrs [for ruggedized range: 70°C, t = 16 hrs] (2)
	IACS E10	60°C, t = 16 hrs + 70°C, t = 2 hrs [for ruggedized range: 70°C, t = 18 hrs] (2)
Cold	IEC 60068-2-1 (Ab & Ad) IACS E10	0°C ... -25°C, t = 16 hrs + power on at 0°C [for ruggedized range: power on at -25°C] (2)
Damp heat, steady state (continuous humidity)	IEC 60068-2-78 (Cab); IACS E10	55°C, 93% relative humidity, t = 96 hrs [for ruggedized range: 60°C] (2)
Damp heat, cyclic (cyclical humidity)	IEC 60068-2-30 (Db); IACS E10	55°C ... 25°C, 93...95% relative humidity, 2 cycles t = 12 hrs + 12 hrs
Change of temperature	IEC 60068-2-14 (Na & Nb)	0°C ... 60°C, 5 cycles t = 6 hrs + 6 hrs [for ruggedized range: -25 ... 70°C] (2)

Name of test	Standards	Levels
Withstand to climatic variations (1) (power off)		
Dry heat	IEC/EN 61131-2; IEC 60068-2-2 (Bb & Bd) IEC/EN 60945	85°C, t = 96 hrs
Cold	IEC/EN 61131-2; IEC 60068-2-1 (Ab & Ad); IACS E10	-40°C, t = 96 hrs
Damp heat, cyclic (cyclical humidity)	IEC/EN 61131-2; IEC 60068-2-30 (Db)	55°C ... 25°C, 93...95% relative humidity, 2 cycles t = 12 hrs + 12 hrs
Change of temperature (thermal shocks)	IEC/EN 61131-2; IEC 60068-2-14 (Na & Nb)	-40°C ... 85°C, 5 cycles t = 3 hrs + 3 hrs

(1) Devices must be installed, wired and maintained in accordance with the instructions provided in the manual "Grounding and Electromagnetic Compatibility of PLC Systems".

(2) Refer also to the chapter "Treatment for severe environments".

(CE): tests required by European CE directives and based on IEC/EN 61131-2 standards.

Technical appendices

Automation product certifications

EC regulations

Some countries require certain electrical components to undergo certification by law. This certification takes the form of a certificate of conformity to the relevant standards and is issued by the official body in question. Where applicable, certified devices must be labelled accordingly. Use of electrical equipment on board merchant vessels generally implies that it has gained prior approval (i.e. certification) by certain shipping classification societies.









Abbreviation	Certification body	Country
CSA	Canadian Standards Association	Canada
RCM (formerly C-Tick)	Australian Communications and Media Authority	Australia, New Zealand
EAC (formerly GOST)	Eurasian conformity	Russia and customs union
UL	Underwriters Laboratories	USA

Abbreviation	Classification authority	Country
IACS	International Association of Classification Societies	International
ABS	American Bureau of Shipping	USA
BV	Bureau Veritas	France
DNV	Det Norske Veritas	Norway
GL	Germanischer Lloyd	Germany
LR	Lloyd's Register	UK
RINA	Registro Italiano Navale	Italy
RMRS	Russian Maritime Register of Shipping	Russia
RRR	Russian River Register	Russia
CCS	China Classification Society	China

The tables below provide an overview of the situation as at 9th January 2014 in terms of which certifications (listed next to their respective bodies) have been granted or are pending for our automation products.

Up-to-date information on which certifications have been obtained by products bearing the Schneider Electric brand can be viewed on our website: www.schneider-electric.com

Product certifications

Certified Certification pending	Certifications							
	 UL USA	 CSA Canada	 RCM Australia	 EAC (9) Russia	Hazardous locations (1) Class I, div 2 USA, Canada	   (6)	  TÜV Rheinland	
Modicon OTB								
Modicon STB					FM	Zone 2 (2)(5)		
Modicon Telefast ABE 7								
ConneXium					(2)			
Magelis iPC/GTW		(3)		(2)	(3)	Zone 2/22 (2)		
Magelis XBT GT		(3)		(2)	(2) (3)	Zone 2/22 (2)(5)		
Magelis XBT GK		(3)			(3)			
Magelis XBT N/R/RT					CSA	Zone 2/22 (2)(5)		
Magelis HMI GTO		(3)		(2)	(3)	(2)		
Magelis HMI STO/STU		(3)		(2)	(2)(3)	(2)		
Modicon M340					CSA	Zone 2/22 (2)(8)		
Modicon M580								
Modicon X80 I/O					CSA	Zone 2/22 (2)(8)		
Modicon Momentum					FM			
Modicon Premium				(2)	CSA			
Modicon Quantum				(2)	CSA, FM (2)	Zone 2/22 (2)		
Modicon Quantum Safety				(2)	CSA	Zone 2/22 (2)	SIL 2, SIL 3 (7)	
Preventa XPSMF							SIL 3 (7)	
Modicon TSX Micro					CSA			
Phaseo	(3)							
Twido	(4)	(4)			CSA/UL (4)			

(1) Hazardous locations: According to ANSI/ISA 12.12.01, CSA 22.2 No. 213 and FM 3611, certified products are only approved for use in hazardous locations categorized as Class I, division 2, groups A, B, C and D, or in non-classified locations.

(2) Depends on product; please visit our website: www.schneider-electric.com.

(3) North American certification cULus (Canada and USA).

(4) Except for AS-Interface module TWD NOI 10M3, CE only.

(5) For zones not covered by this specification, Schneider Electric offers a solution as part of the CAPP (Collaborative Automation Partner Program). Please consult our Customer Care Centre.

(6) Refer to the instructions supplied with each ATEX and/or IECEx certified product.

(7) According to IEC 61508. Certified by TÜV Rheinland for integration into a safety function of up to SIL 2 or SIL 3.

(8) Can be used in gassy mines under certain conditions.











(9) Formerly GOST. GOST will be replaced by EAC after certificates are renewed.

Technical appendices

Automation product certifications

EC regulations

Merchant navy certifications

Certified Certification pending	Shipping classification societies										
											
	ABS	BV	DNV	GL	KRS	LR	RINA	RMRS	RRR	PRS	CCS
	USA	France	Norway	Germany	Korea	Great Britain	Italy	Russia	Russia	Poland	China
Modicon OTB											
Modicon STB	(1) (2)	(2)	(2)	(2)		(2)	(2)				
Modicon Telefast ABE 7											
ConneXium											
Magelis iPC/GTW				Bridge (2)							
Magelis XBT GT	(2)	(2)	(2)	(2)		(2)	(2)	(2)	(2)		
Magelis XBT GK											
Magelis XBT N/R											
Magelis XBT RT											
Magelis HMI GTO											
Magelis HMI STO/STU		(2)	(2)								
Modicon M340								(2)	(2)		
Modicon M580											
Modicon X80 I/O								(2)	(2)		
Modicon Momentum											
Modicon Premium											
Modicon Quantum											
Modicon TSX Micro											
Phaseo											
Twido											

(1) Also covers US Navy requirements **ABS-NRV** part 4.

(2) Depends on product; please visit our website: www.schneider-electric.com.

EC regulations

European Directives

The open nature of the European markets assumes harmonization between the regulations set by the member states of the European Union. European Directives are texts whose aim is to remove restrictions on free circulation of goods and which must be applied within all European Union states.

Member states are obligated to incorporate each Directive into their national legislation, and to simultaneously withdraw any regulations that contradict it.

Directives - and particularly those of a technical nature with which we are concerned - merely set out the objectives to be fulfilled (referred to as "essential requirements"). Manufacturers are responsible for taking the necessary measures to establish that their products conform to the requirements of each Directive applicable to their equipment.

As a general rule, manufacturers certify compliance with the essential requirements of the Directive(s) that apply to their products by applying a CE mark. The CE mark is affixed to our products where applicable.

Significance of the CE mark

The CE mark on a product indicates the manufacturer's certification that the product conforms to the relevant European Directives; this is a prerequisite for placing a product which is subject to the requirements of one or more Directives on the market and allowing its free circulation within European Union countries. The CE mark is intended for use by those responsible for regulating national markets.

Where electrical equipment is concerned, conformity to standards indicates that the product is fit for use. Only a warranty by a well-known manufacturer can provide reassurance of a high level of quality.

As far as our products are concerned, one or more Directives are likely to apply in each case; in particular:

- The Low Voltage Directive (2006/95/EC)
- The Electromagnetic Compatibility Directive (2004/108/EC)
- The ATEX CE Directive (94/9/EC)

Hazardous substances

These products are compatible with:

- The WEEE Directive (2002/96/EC)
- The RoHS Directive ((2011/65/EU)
- The China RoHS Directive (Standard SJ/T 11363-2006)
- The REACH regulations Directive (EC 1907/2006)

Note: Documentation on sustainable development is available on our website www.schneider-electric.com (product environmental profiles and instructions for use, ROHS and REACH directives).

End of life (WEEE)

End of life products containing electronic cards must be dealt with by specific treatment processes.

When products containing backup batteries are unusable or at end of life they must be collected and treated separately. Batteries do not contain a percentage by weight of heavy metals above the limit specified by European Directive 2006/66/EC.

A dedicated services offer for your installed base

- Maintenance and support services page 7/2
- Consultancy services page 7/3
- Modernization solutions page 7/3
- Customization services page 7/3

A dedicated services offer for your installed base

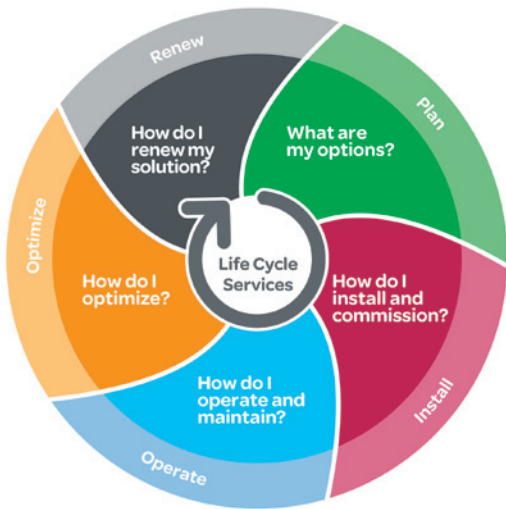

Schneider Electric, with its experts, products and dedicated tools, provides services such as system design, consultancy, maintenance contracts, modernisation of facilities or delivering projects.

The Schneider Electric services offer is structured around several key areas:

- Maintenance and support services:
 - A set of services to help maintain reliability and availability of automated control systems. These services may be the subject of a bespoke maintenance contract to meet your requirements more closely.
- Consultancy services:
 - Diagnostics of the installed base
- Modernization solutions:
 - Migration solutions including consultancy, expertise, tools and technical support to help ensure a smooth transition to newer technology while keeping the wiring and the encoding in most cases.

Customization services are also available to accommodate specific requirements. For more information, please consult the specific pages on our website www.schneider-electric.com/automationservices

Maintenance and support services

Spare parts, exchanges and repairs

Everything you need to get equipment working again as quickly as possible

Solutions to respond very quickly to requests for spare parts, exchanges and repairs to your installed automation equipment (automation platforms, Human Machine Interfaces, drives, distributed I/O):

- Spare parts management:
 - Identification of critical parts
 - Stock of spare parts: a Schneider Electric owned stock of spare parts, on your site or in one of our warehouses, with immediate availability on site or a contractually agreed delivery time if stored off site
 - Testing of spare parts stored on site
 - Automatic stock filling
- Repairs:
 - Broken down products are repaired in a network of worldwide repair centres. For each repaired product, our experts provide a detailed report.
- On-site repair:
 - Our experts' knowledge and expertise
 - Monitoring of specific repair procedures
 - Availability of our teams to respond 24/7
- Exchanges:
 - With standard replacements, receive a new or reconditioned product before the broken down product has even been sent back
 - Fast exchanges offer the option to receive the replacement product within 24 hours (in Europe)

Preventive maintenance

Improving and guaranteeing the long-term reliability and performance of your installations

Schneider Electric's preventive maintenance expert assesses your site, the equipment to be managed and sets up a maintenance program to accommodate specific requirements. A list is provided of the tasks to be performed and their frequency, including site-specific tasks, describing how preventive maintenance is to be managed.

Extended warranty

An additional manufacturer warranty covering replacement or repair of the equipment

The extended warranty offers the option to take out a 3-year warranty. The warranty period can vary according to the geographical area, consult your Customer Care Centre.

Online support

Access to dedicated experts

Priority access to experts who can answer technical questions promptly concerning equipment and software both on sale and no longer commercially available.

Software subscription

Access to software upgrades and new features

By subscribing to software updates, users are able to:

- Purchase licences
- Receive updates, upgrades, software migrations and transitions
- Download software from Schneider Electric's software library

Consultancy services

M2C (Maintenance and Modernization Consultancy)

Professional tools and methods, proven experience of managing obsolescence and updating installed bases, to reduce downtimes and improve performance

With our maintenance and modernization consultancy offer, Schneider Electric will help you check the state of your installed base by:

- Defining the scope and depth of the analysis in collaboration with you
- Collecting the technical data without shutting down production
- Analyzing and identifying avenues for improvement
- Producing a recommendation plan

Customer benefits:

- Learning about the components that make up the installed base and how up-to-date they are
- Better downtime anticipation
- Expert advice designed to improve performance

Modernization solutions

Migration to PlantStruxure

Proven expertise, tools and methods to give you a clear vision of the improvement opportunities and guide you toward a successful modernization project



To find out more about PlantStruxure architectures, please visit our website www.schneider-electric.com/PlantStruxure

Schneider Electric offers a gradual program of modernization through a series of products, tools and services that allow you to upgrade to newer technology. There are several stages in this gradual modernization program:

- Partial program: replacement of an old component with a new one
- Staggered program: gradual incorporation of new offers in the system
- Total program: total renovation of the system

The table below lists our various migration offers:

Wide range of migration offers

Solution		Change the CPU	Keep the I/O racks & wiring	Change the I/O racks & keep the wiring	Migrate your application	Manage your project	Execute your project
Platform (1)	TSX47 to TSX107	☑	☑	☑	☑	☑	☑
	April series 1000			☑	☑	☑	☑
	Modicon ●84, Compact	☑	☑	☑	☑	☑	☑
	April SMC				☑	☑	☑
	Merlin Gerin PB				☑	☑	☑
	AEG	☑	☑	☑	☑	☑	☑
	Symax	☑			☑	☑	☑
	Rockwell SLC500			☑	☑	☑	☑

☑

 Service available

(1) Our migration service offer also includes SCADA, Human Machine Interfaces, drives, communication networks and distributed I/O.

Customization services

Schneider Electric is able to meet your specific requirements and provide you with adapted products:

- Protective coating for Human Machine Interfaces, automation platforms and distributed I/O modules for use in harsh environments
- Customized cable lengths to match your specific needs
- Customized front panels for Human Machine Interfaces

Note: To check availability of services required, please contact our Customer Care Centre.

Technical appendices

- Ethernet network infrastructure page 8/2

Index

- Product reference index..... page 8/8

Presentation

The ConneXium Industrial Ethernet offer comprises a complete family of products and tools (including the ConneXium Network Manager (CNM) software tool) required to build the infrastructure of an Industrial Ethernet network. The following pages provide information on network design and component selection.

Office Ethernet versus Industrial Ethernet

There are three main areas of differentiation between Ethernet applications in an office environment and those in an industrial environment:

- Environment
- Layout (not physical layer specification)
- Performance

Contrary to the office environment and even though ISO/IEC is working on it, as yet there are no clearly defined specifications for Ethernet devices intended for industrial applications. The specifications of what it is called Industrial Ethernet are defined by different agencies or entities based upon its nature and what the automation market has traditionally used.

The environmental specifications of Industrial Ethernet devices are defined by the traditional agencies that define the environmental specifications for standard industrial devices (UL, CSA, CE, etc.).

IEEE 802.3 defines the physical layer specifications of the Ethernet network (types of connector, distance between devices, number of devices, etc.) while standard 11801 (similar to TIA/EIA 568B and CENELEC EN 50173) provides layout guidelines for installers.

The performance specifications are currently being drawn up by ISO/IEC.

Ethernet 802.3 principles

The Ethernet 802.3 Link Layer is based on a collision detection mechanism (CSMA CD) whereby every node whose information has collided on the network detects the collision and re-sends the information.

The process of re-sending information causes delays in its propagation and could affect the application.

A collision domain is a group of Ethernet end devices interconnected by hubs or repeaters (devices that receive information and send it out to all their other ports, no matter where the destination device is connected). This means that all devices will be affected by collisions.

With full duplex switches (devices that receive information and only send it out through the port to which the destination device is connected), there are no collision domains.

Therefore, for industrial automation applications it is highly advisable to use full duplex switches to interconnect devices. This will help eliminate collision domains.

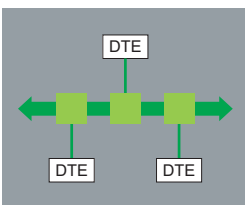
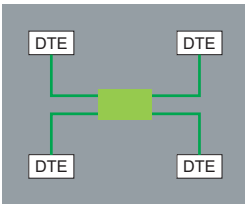

Different network topologies

Star topology

In a star topology, all devices and Data Terminal Equipment (DTE) are connected through an intermediate device.

Ethernet star

In an Ethernet star the intermediate device may be a **switch**. The star is the most commonly used topology in corporate networks and is currently adopted in almost every automation application. As mentioned previously, for industrial Ethernet applications the use of full duplex switches as the central device rather than hubs is highly recommended.

Deploying star topologies with ConneXium

Star topologies can be implemented with any of the switches in the ConneXium offer.

Bus topology

The bus is one of the most common topologies in traditional industrial automation networks. A single trunk cable connects all devices on the network usually via passive or active T-connectors, or directly chained (daisy chain). Devices can usually be installed anywhere along the bus.

Ethernet bus

An Ethernet bus can be deployed by interconnecting **switches** in line and considering every one of them as the connection for a drop device. An unlimited number of switches can be interconnected to achieve this purpose.

Deploying bus topologies with ConneXium

Bus topologies can be implemented with any of the switches in the ConneXium offer. Switches with 1 or 2 fiber optic ports are particularly suitable for this purpose:

- Switches with 2 fiber optic ports can be used to connect in-line devices.
- Switches with 1 fiber optic port can be used to connect end-of-line devices.

Daisy chain topology

Daisy chain - along the bus - is the other most common topology in traditional industrial automation networks. Cable segments interconnect multiple devices, being the devices "part" of the network cable.

Ethernet daisy chain

Daisy chain is currently not a particularly common Ethernet topology, but it is likely to rise in popularity as more devices become available.

Ethernet daisy chain devices have:

- **2 Ethernet ports** and
- **1 embedded switch.**

Schneider Electric is launching Industrial Ethernet devices on the industrial market for connection in daisy chain architectures.

Deploying daisy chain topologies

No switches are required for daisy chain topologies. All devices have an embedded switch.

Dual port Ethernet at device level is an absolute integral component for daisy chain topologies.

One port on the device connects to one port on each of the two neighboring devices. These neighboring connections make up the daisy chain.

Ethernet switches can be employed in a daisy chain topology when multiple scan chains are in use by the controlling device. It is expected that the Ethernet switch will be located near the controlling device with the different scan chains emanating from the switch.

Different network topologies (continued)

Daisy chain topology (continued)

Limitations of the daisy chain:

Limitations of the daisy chain topology in terms of operational integrity of the network and performance metrics are as follows:

- Dual port Ethernet devices only support 10 Mbps and/or 100 Mbps operational speeds and must use one or the other.
- The network will operate only as fast as the slowest device that is connected to the network.
- In order to improve network traffic latency, the number of devices in a single scan chain is limited to 32 devices. This means that the time for a round trip of a packet through the daisy chain is likely to be less than 5 milliseconds.

The maximum latency of a packet passing through any device in a scan chain is no more than 10 μ s.

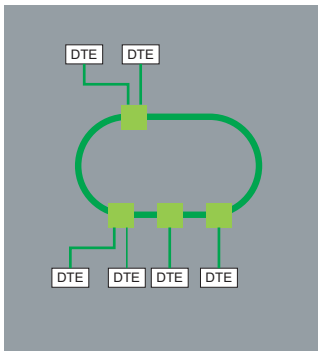

Ring topology

In a ring topology, all devices or network infrastructure components are connected in a loop. Through this type of topology, a type of network redundancy is achieved.

Ring topologies also help improve the availability of the network and its communication to devices.

Ethernet ring

Ethernet rings are usually the backbones of applications in which high availability is required. If ring topology is required then switches that support this feature should be ordered.

Deploying ring topologies using ConneXium

ConneXium offers switches that allow the deployment of single and coupled self-healing rings (see page 2/11 for more information).

Daisy chain loop

A daisy chain loop consists of several daisy chain devices that are placed in a ring topology.

When an Ethernet network forms a loop, all the devices in that loop must use the same protocol (RSTP, MRP, or HIPER-Ring).

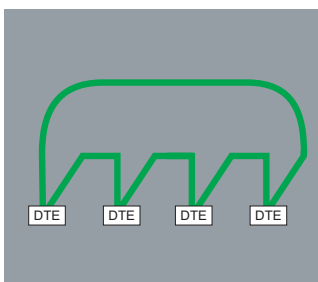

Distance limitations and number of devices per segment

Based on standard 802.3, the distance limits and number of devices in cascade are as follows:

Type	Maximum segment length (1)	Maximum segment length (offered by ConneXium devices)	Maximum number of hubs in cascade	Maximum number of switches in cascade
10BASE-T	100 m/328.08 ft	100 m/328.08 ft	4	Unlimited
100BASE-TX	100 m/328.08 ft	100 m/328.08 ft	2	Unlimited
1000BASE-T	100 m/328.08 ft	100 m/328.08 ft	–	Unlimited
10BASE-FL	2,000 m/6,561.66 ft	3,100 m/10,170.57 ft (2)	11 (fiber ring)	–
100BASE-FX	412 m/1,351.70 ft 2,000 m/6,561.66 ft	4,000 m/13,123.32 ft with multimode fiber, 32,500 m/106,627 ft with singlemode fiber (3)	–	Unlimited
1000BASE-SX	275 m/902.23 ft	–	–	Unlimited

(1) Based on 802.3, full duplex/half duplex.

(2) Depends on the optical fiber budget and fiber attenuation.

(3) Depends on the optical fiber budget and fiber attenuation, typical specification is 2,000 m/6,561.66 ft for multimode and 15,000 m/49,212.45 ft for singlemode.

Physical media

The Ethernet 802.3 standard defines the Physical Layer. A summary of the most common media is given below:

Type	Data rate	Cable type		Connector type	
		Defined by 802.3	Recommended by Schneider Electric	Defined by 802.3	Recommended by Schneider Electric
10BASE-T	10 Mbps	CAT 3 - UTP	CAT 5E - STP	RJ45	RJ45
100BASE-TX	100 Mbps	CAT 5 - UTP	CAT 5E - STP	RJ45	RJ45
1000BASE-T	1 Gbps	CAT 5 - UTP	CAT 5E - STP	RJ45	RJ45
10BASE-FL	10 Mbps	Two multimode optical fiber cables typically 62.5/125 µm fiber, 850 nm light wavelength	Two multimode optical fiber cables typically 62.5/125 µm fiber, 850 nm light wavelength	ST	ST
100BASE-FX	100 Mbps	Two multimode optical fibers typically 62.5/125 µm multimode fiber, 1,300 nm light wavelength	Two multimode optical fibers typically 62.5/125 µm multimode fiber, 1,300 nm light wavelength	ST	SC
		–	Two monomode optical fibers typically 9/125 µm multimode fiber, 1,300 nm light wavelength	–	SC
1000BASE-SX	1 Gbps	Two 62.5/125 or 50/125 multimode optical fibers, 770 to 860 nm light wavelength	Two 62.5/125 µm or 50/125 m multimode optical fibers, 1,300 nm light wavelength	SC	LC
1000BASE-LX	1 Gbps	–	Two 9/125 µm singlemode optical fibers, 1,300 nm light wavelength	–	LC

Note: These specifications are defined by IEEE 802.3. However, some of the cables are no longer being developed. For instance, for 10BASE-T and 100BASE-TX, a CAT-5E cable is used.

Management

Ethernet devices in general (end-of-line devices and cabling devices) can be divided into two categories: unmanaged and managed devices.

- **Unmanaged** devices are those devices for which there is no option to configure or control any of the device parameters.
- **Managed** devices are those devices whose parameters can be configured or controlled (managed) and their internal data can be accessed.

The ConneXium product line offers both types of device.

There is also a third, unspecified category of device, which is normally classed as a managed device. However, there is one major difference: although this device allows access to its internal data, it cannot be controlled and/or configured.

Managed devices

Managed devices offer the following features:

- **Traffic optimization and filtering** - The aim is to increase the bandwidth, or the traffic capacity in a network (some of the features in this area are message and port priority, flow control, multicast filtering, broadcast limiting, IGMP snooping, Vlan, etc.).
- **VLAN** - A virtual LAN (VLAN) consists of a group of network participants in one or more network segments who can communicate with each other as if they belonged to the same LAN.

VLANs are based on logical (instead of physical) links. The biggest advantage of VLANs is their possibility of forming user groups based on the participant function and not on their physical location or medium.

Since broad/multicast data packets are transmitted exclusively within a virtual LAN, the remaining data network is unaffected. VLAN can also serve as a security mechanism to block unwanted Unicast messages.

- **Security** - This feature helps the user protect the switch from unauthorized access that could result in changes in its configuration and impact the traffic going through the switch (some of the features in this area are port security, read/write community name, etc.).

Users can also set up the switch so that it blocks messages coming from unauthorized "device" source addresses connected to the switch.

- **Time synchronization** - This feature allows all devices in a network to be synchronized according to the time.
- **Network redundancy** - This helps to develop high availability applications.
- **Dual ring switch (DRS)** - These switches are provided with predefined settings to optimize communication performance and help save time in Ethernet RIO architectures with Modicon Quantum and Modicon M580 automation platforms. DRS switches are mandatory to build Ethernet RIO architectures in which sub-rings have to be connected to the main Ethernet ring.

Redundancy

To develop high availability applications, “redundancy” in the networking infrastructure is the answer. Developers can help avoid losing network segments by implementing a single ring or a coupled ring architecture.

Single ring

The first level of redundancy is achieved by implementing a single ring. ConneXium switches allow the set up of backbone ring configurations.

ConneXium switches support three redundancy protocols: HIPER-Ring, MRP, and RSTP.

The ring is constructed using HIPER-Ring ports. If an error is detected in one section of the line, a ring structure of up to 50 switches transforms back to a line-type configuration within 0.5 seconds.

With a Modicon Quantum or a Modicon M580 Ethernet RIO architecture, the recovery loop can be optimized to less than 50 ms thanks to the RSTP protocol implemented in the different devices.

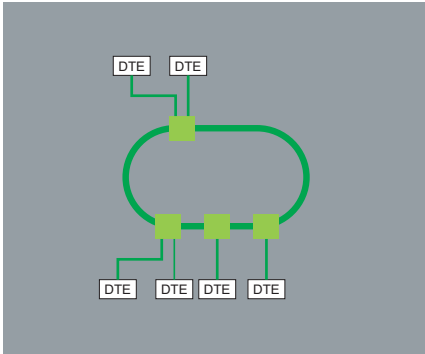

Dual ring

The second level of redundancy is achieved by implementing a dual ring. The control intelligence built into ConneXium switches allows the redundant coupling of HIPER-Rings and network segments.

As for a single ring, the recovery time can be optimized to less than 50 ms for 16 switches or 32 RIO drop adapters thanks to the RSTP protocol.

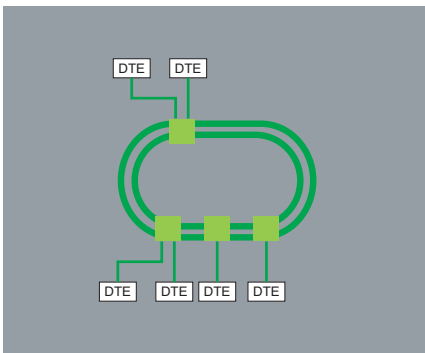

Mesh topology using the rapid “Spanning Tree” protocol

A third level of redundancy can be achieved by implementing a mesh topology. In simple terms, “Spanning Tree” is a protocol that provides a single path for the signal, when multiple paths exist. If the active path is broken, the “Spanning Tree” protocol enables one of the alternative paths.

ConneXium switches offer this possibility.

Security

ConneXium firewalls help improve security for industrial networks while meeting the needs for cybersecurity.

Firewall rules can be defined to control access levels at the host, protocol, and port levels.

Further rules can be defined for other purposes, such as protecting access to Modbus/TCP function codes and register levels, or EtherNet/IP CIP objects and service codes.

ConneXium firewalls can also offer layer 3 routing, network address translation (NAT), and virtual private networks (VPN) for advanced security zoning of critical industrial networks.

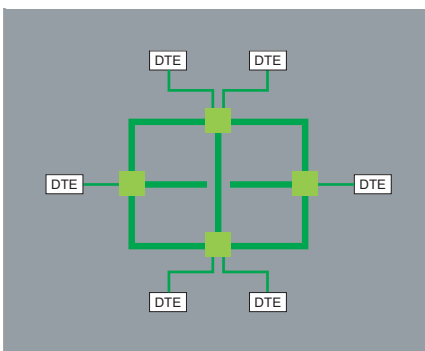

1	
110XCA28201	4/21
110XCA28202	4/21
110XCA28203	4/21
170DNT11000	3/31

4	
490NAD91103	3/31
490NAD91104	3/31
490NAD91105	3/31
490NOR00003	2/18
490NOR00005	2/18

9	
990NAA26320	4/21
990NAA26350	4/21

B	
BMECRA31210	2/17
BMECRA31210C	5/5
BMEP581020	1/23 2/18 2/19
BMEP581020H	5/3
BMEP582020	1/23 2/18 2/19
BMEP582020H	5/3
BMEP582040	1/23 2/18 2/19
BMEP582040H	5/3
BMEP583020	1/23 2/18 2/19
BMEP583040	1/23 2/18 2/19
BMEP584020	1/23 2/18 2/19
BMEP584040	1/23 2/18 2/19

BMEXBP0400	1/25
BMEXBP0400H	5/4
BMEXBP0800	1/25
BMEXBP0800H	5/4
BMEXBP1200	1/25
BMEXBP1200H	5/4
BMXCRA31200	2/17
BMXCRA31210	2/17
BMXERT1604T	4/37
BMXNOC0402	2/17 3/25
BMXNRP0200	2/17
BMXNRP0201	2/17
BMXRMS004GPF	1/23 5/3
BMXXBC008K	1/29 2/19 5/4
BMXXBC015K	1/29 2/19 5/4
BMXXBC030K	1/29 2/19 5/4

BMXXBC050K	1/29 2/19 5/4
BMXXBC120K	1/29 2/19 5/4

BMXXBE1000	1/28 2/18
BMXXBE1000H	5/4
BMXXBE2005	1/28 2/18

BMXXBP0400	1/28
BMXXBP0400H	5/4
BMXXBP0600	1/28
BMXXBP0600H	5/4
BMXXBP0800	1/28

BMXXBP0800H	5/4
BMXXBP1200	1/28
BMXXBP1200H	5/4
BMXXCAUSBH018	1/23 4/21 5/3

BMXXCAUSBH045	1/23 4/21 5/3
BMXXEM010	1/25 5/4
BMXXSP0400	1/25 5/4

BMXXSP0600	1/25 5/4
BMXXSP0800	1/25 5/4
BMXXSP1200	1/25 5/4

S	
SR2CBL06	4/21
STBEHC3020KC	2/23
STBNPD2212	3/31
STBXCA4002	4/21
STBXSP3010	1/25 5/4
STBXSP3020	1/25 5/4

T	
TCSECN3M3M1S4	2/17
TCSECN3M3M1S4U	2/17
TCSEGDB23F24FA	3/29
TCSEGDB23F24FK	3/29
TCSEGA23F14F	3/31
TCSEGA23F14FK	3/31 5/5
TCSESM063F2CS1	2/17
TCSESM063F2CU1	2/17
TCSESM083F23F1	2/17
TCSMCN3M4M3S2	5/5
TCSWAAC13FB	4/21
TCSXCN3M4F3S4	5/5
TLXCDLFOFS35	4/35
TLXCDLTOFS35	4/35
TLXCDLUOFS35	4/35
TLXCDSTOFS35	4/35
TLXCDSUOFS35	4/35
TSXCBY010K	1/29 2/19 5/4

TSXCBY030K	1/29 2/19 5/4
TSXCBY050K	1/29 2/19 5/4

TSXCBY120K	1/29 2/19 5/4
TSXCBY180K	1/29 2/19 5/4

TSXCBY280KT	1/29 2/19 5/4
TSXCBY1000	1/29 2/19 5/4

TSXCBYACC10	1/29 2/19 5/5
TSXCBYK9	1/29 2/19 5/5

TSXCRJMD25	4/21
TSXCUSB485	4/21
TSXPBSCA100	3/31
TSXPBSCA400	3/31
TSXPCX1031	4/21
TSXTLYEX	1/29 2/19 5/5

U	
UAGSBTCFUCD10	4/29
UAGSBTDFUWB13	4/29
UNYDFFXZZSPA80	4/25
UNYLAGZAUWB20	4/29
UNYLFZZAUWB12	4/29
UNYLHVZAUWB10	4/29
UNYLPZAUWB	4/29
UNYLSYSFU	4/29
UNYLTSAUWB10	4/29
UNYSPUEEFC80	4/20
UNYSPUEFFCD80	4/20
UNYSPUEFGCD80	4/20
UNYSPUEFTCD80	4/20
UNYSPUEFUCD80	4/20
UNYSPUEZFC80	4/20
UNYSPUEZGCD80	4/20
UNYSPUEZGTCD80	4/20
UNYSPUEZLGC80	4/20
UNYSPUEZLTCD80	4/20
UNYSPUEZLUCD80	4/20
UNYSPUEZTCD80	4/20
UNYSPUEZUCD80	4/20
UNYSPUEZUGCD80	4/20
UNYSPULFFCD80	4/19
UNYSPULFGCD80	4/19
UNYSPULFTCD80	4/19
UNYSPULFUCD80	4/19
UNYSPULZFC80	4/19
UNYSPULZGCD80	4/19
UNYSPULZGTCD80	4/19
UNYSPULZMGCD80	4/19
UNYSPULZMTC80	4/19
UNYSPULZMUCD80	4/19
UNYSPULZSGCD80	4/19

UNYSPULZSTCD80	4/19
UNYSPULZSUCD80	4/19
UNYSPULZTCD80	4/19
UNYSPULZUCD80	4/19
UNYSPULZUGCD80	4/19
UNYSPUSFGCD80	4/18
UNYSPUSFTCD80	4/18
UNYSPUSFUCD80	4/18
UNYSPUSZGCD80	4/18
UNYSPUSZGTCD80	4/18
UNYSPUSZTCD80	4/18
UNYSPUSZUCD80	4/18
UNYSPUSZUGCD80	4/18
UNYSPUZFUCD80	4/23
UNYXCAUSB033	4/21

Schneider Electric Industries SAS

www.schneider-electric.com

Head Office
35, rue Joseph Monier
F-92500 Rueil-Malmaison
France

The information provided in this documentation contains general descriptions and/or technical characteristics of the performance of the products contained herein. This documentation is not intended as a substitute for and is not to be used for determining suitability or reliability of these products for specific user applications. It is the duty of any such user or integrator to perform the appropriate and complete risk analysis, evaluation and testing of the products with respect to the relevant specific application or use thereof. Neither Schneider Electric nor any of its affiliates or subsidiaries shall be responsible or liable for misuse of the information contained herein.

Design: Schneider Electric
Photos: Schneider Electric
Printed by:

DIA6ED2131202EN

