

TASKMASTER

5100 SERIES

INSTALLATION INSTRUCTIONS & PARTS LIST

Horizontal or Vertical Mounting Industrial / Commercial Unit Heater

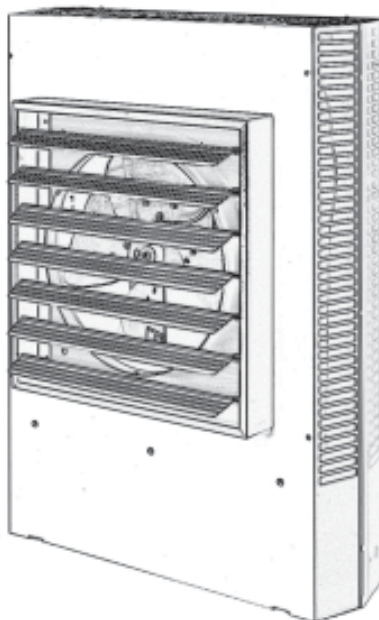
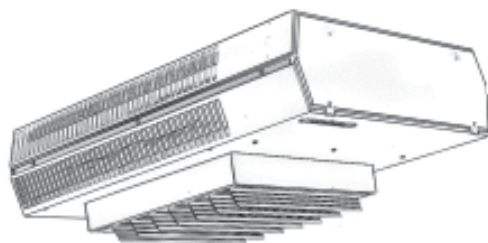

TPI Corporation
P.O. Box 4973
Johnson City, TN
37602-4973

America's Comfort Conditioning Company

ATTENTION: Read carefully before attempting to install, operate or service the TaskMaster Unit Heater. Retain these installation instructions for future use.

PRODUCT FEATURES

Forced air electric unit heater available in 208, 240/208, 227, 480, 550 or 600 volt as standard.

Ten standard heating capacities of 3.3 KW/11,260 BTUH thru 50.0 KW/170, 600 BTUH.

208 and 240/208 volt models are single phase field convertible to three phase on 3.3 thru 10.0 KW Models. (Single phase only available on 3.3, 5.0, 7.5 and 10 KW 277 volt models.

Specially designed inlet louver allows the fan to pull cool air evenly across the high mass all-steel element.

Outward drawn venturi and adjustable louver assembly further directs the outlet air in a uniform pattern to meet specific air pattern requirements in either the horizontal or vertical mounting position.

Optional wall/ceiling or vertical mounting brackets (as required).

Four position weld nuts supplied in case top and back for field mounting by threaded rods or eye bolt with chain. (Hardware supplied by others).

Optional radial or anemostat diffusers lending air pattern versatility when mounted vertically.

Modular control kits for field installation. Disconnect switch, thermostat, summer fan switch, heat recovery thermostat. All kits with spade terminals (Except disconnect switch).

Single point terminal board wiring of integral control kits.

24 volt low voltage control circuit standard on all contactor and transformer models.

Roomy control box with access door locked into position by two (2) 1/4 turn fasteners for ease of installation.

Revised 10/09
ECO 1-6174
Form 9632

IMPORTANT: OWNER SHOULD RETAIN THESE INSTRUCTIONS FOR FUTURE REFERENCE

PROPER LOCATION INSTRUCTIONS

Once the total heating load is calculated, the quantity and capacity of the unit heaters must be determined. because a large number of low-capacity heaters provides more uniform heat distribution. This approach is recommended when the area will be occupied by a relatively large number of sedentary personnel, (i.e. working on production lines and at benches.)

A large number of smaller capacity unit heaters tends to prevent hot drafts, reduces noise levels, and increases diversity of load to help reduce electrical demand and operating costs.

In warehouses where even heat distribution and constant temperatures are less important, a smaller number of high capacity units can be used -- in many cases reducing installation cost. To maintain reasonable heat distribution and reduce severe stratification even in lower bay areas, the total air volume of the space should pass through the unit heaters about three times per hour. (Take total cubic feet and divide by 20 in order to determine proper total heater CFM rating.)

It is important that the rated voltage of the heating equipment match the supply voltage. Supply voltage in excess of the heater rated voltage can damage equipment. Supply voltage lower than the rated heater voltage will decrease heater output as well as run the risk of damaging some components.

Horizontal unit heaters are recommended in low bay areas with maximum 15 to 18 foot ceilings. These should be concentrated along outside wall or other areas of greatest heat loss; spaced to set up a generally circular air movement, each heater supporting the air stream of the other. Additional vertical down below unit heaters with appropriate accessory diffusers can be located to counteract ceiling heat losses (see Figure 1 Location charts).

Figure 1 Location Instructions

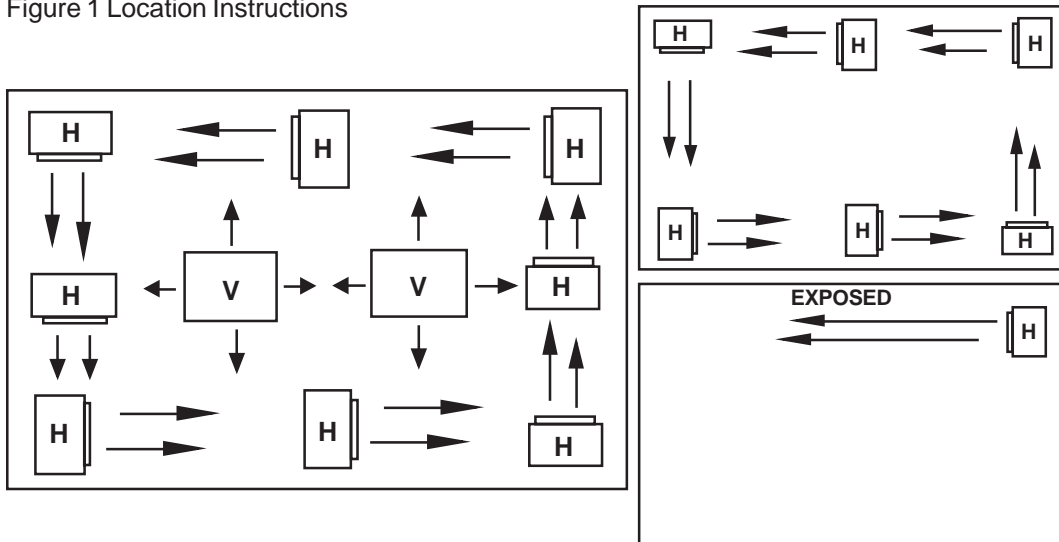

GENERAL SAFETY INFORMATION / CAUTION:

Follow all local electrical and safety codes, as well as the National Electrical Code (NEC) and the Occupational Safety and Health Act (OSHA).

To avoid possible electrical shock, be sure the electrical current is turned off at the main switch prior to wiring or servicing of unit.

If the power disconnect is not integral and is out-of-sight, lock it in the open position and tag to prevent unexpected application of power prior to performing any service or maintenance of the unit.

The unit when installed must be electrically grounded in accordance with the National Electrical Code and standard industry practice.

Make certain that the power source conforms to the requirements of your equipment. See Table 2 on page 6 for wire and circuit size

Check heater voltage and phase on rating label to confirm that it matches the electric service supply.

Wiring diagrams of the heater and supply connections are permanently attached to the inside of the heater access door. All terminals are coded in accordance with the wiring diagram. Accessory wiring are shown on the unit wiring diagram and supporting literature.

The heater must be mounted at least 7' above the floor to prevent accidental contact with the fan blade which could cause injury. Install unit so there are no obstructions to the intake or discharge. Maintain clearances as shown on Table 1, 2, Fig. 1 & 2.

The wall/ceiling mounting structure and anchoring provisions must be on sufficient strength to support the combined weight of the heater and mounting bracket.

PRINCIPLES OF OPERATION

Upon a call for heat from the floor level or unit mounted optional accessory thermostat, the unit fan motor and heating elements shall be energized and remain ON until temperature reaches setting of thermostat; at which time the heating elements shall be deenergized.

The fan motor shall continue to run and purge heater casing of residual heat until setting of fan override is reached, then the fan motor shall be deenergized.

For those units with a factory installed two speed fan switch (25-50KW), the unit as shipped from the factory is set to "low" speed. Customer option to set to "high" speed. For those units available with subdivided circuits, the accessory two stage thermostat (optional) will, upon a call for heat, energize fan motor and the first stage heating element. Should temperature continue to fall, the thermostat shall energize the second stage heating element.

Upon a rise in space conditions towards setting of the thermostat, the two stages of heating elements shall be deenergized in reverse sequence.

The fan motor shall continue to run and purge heater casing of residual heat until setting of fan override is reached, then the fan motor shall be deenergized.

The accessory unit mounted stratification thermostat will energize the unit heater fan motor upon a rise in temperature above its setting.

When the unit mounted stratification thermostat closes on a temperature rise and at the same time the floor thermostat calls for heat, the motor shall be energized immediately and the heating element shall be energized, as previously described.

The automatic reset safety high limit shall deenergize the heating elements and control circuits should the temperature exceed the setting of this device. The fan safety override shall energize fan motor any time the setting of this device is exceeded so as to purge heater casing of excess residual heat.

When the accessory fan switch is placed in the ON position (for summer air circulation), the unit heater fan motor shall be energized.

NOTE: The wall thermostat is to be set to the OFF position during this mode of operation (units with contactors).

For those accessory thermostats equipped with an integral fan switch, place the switch in the HEAT, or AUTO position for operation of the fan and elements which shall then be under control of the thermostat as described above.

When switch is placed in the OFF position, the unit shall be deenergized. When switch is placed in the FAN position, elements shall be deenergized and fan shall be immediately energized.

VERTICAL DISCHARGE UNITS - AIR PATTERNS

USED ON	MAX MTG HT.	A	B	STOCK NO.	MAX MTG HT.	A	MAX MTG HT.	A	STOCK NO.	STOCK NO.	MAX MTG HT.		A	
											45°	OPEN	45°	OPEN
											3.3 & 5.0 KW	9	20	10
7.5 & 10.0 KW	12	40	22	STD	12	30	10	30	AD5120	RD5120	0	14	36	30
15.0 & 20.0 KW	18	52	30	STD	18	40	15	38	AD5120	RD5120	14	21	42	35
25.0 & 30.0 KW	22	75	42	STD	22	55	17	50	AD5150	RD5150	20	30	62	44
40.0 & 50.0 KW	24	84	47	STD	24	64	20	60	AD5150	RD5150	18	28	68	54

STD = Standard N/A = Not Applicable

Optional diffusers lend added air pattern versatility to individual vertical down blow installations as shown in above illustrations.

INSTALLATION INSTRUCTIONS

TASKMASTER -- 5100 SERIES UNIT HEATER

ATTENTION: READ INSTRUCTION CAREFULLY

All electric unit heaters are shipped fully assembled. Installation includes hanging the unit, mounting the built-in and remote accessories, wiring of optional control devices, and electrical wiring to the unit.

To insure proper delivery of the heated air to desired areas, follow the mounting height and air projection tables include in these instructions. Follow Fig. 1 & 2 for minimum wall and ceiling clearances.

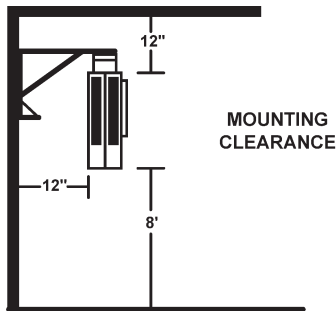

FIG. 1
HORIZONTAL DISCHARGE

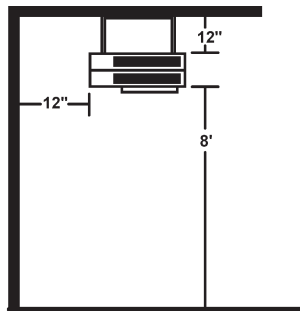

FIG. 2
VERTICAL DISCHARGE

The wall and/or ceiling structure must be sufficient to support the combined weight of the heater and any mounting bracket and accessories.

Be sure power source is deenergized before installing heater. Check heater voltage and phase listed on heater date tape on back of unit to make sure they are the same as the electrical service supplied.

Certain units are convertible from single to three phase service. Follow instructions noted on the unit wiring diagram for this conversion. Units that carry a dual voltage rating (HF) require specific wiring changes when converting from 240 to 208 volt service supplied.

Open the access panel (2 1/4 turn fasteners).

Remove the desired knock-out(s) on back of the heater.

Install any optional accessories following their installation instructions before mounting unit. Following the correct unit/accessory wiring diagram, connect the power supply, electrical ground and accessories to the correct terminals or termination points using accepted practices.

Heaters may be mounted in the horizontal or vertical air discharge configuration using factory optional supplied accessory mounting equipment or using special hardware facilities supplied by others.

After the installation is complete, replace the access panel.

Set the controls (thermostat, switch) at their desired control point and apply power to the unit.

Check correct operation.

DIMENSIONS

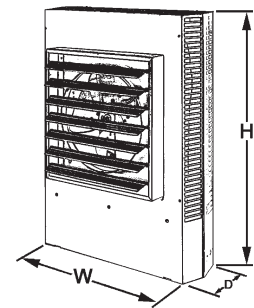

DIMENSIONS (INCHES)			
KW	H	W	D
3.3 - 5.0	17-3/4	14-15/32	6-1/2
7.5 - 10.0	24-5/16	21-1/2	6-1/2
15.0 - 20.0	28-11/16	21-1/2	6-1/2
25.0 - 50.0	34	29-1/4	10-1/16

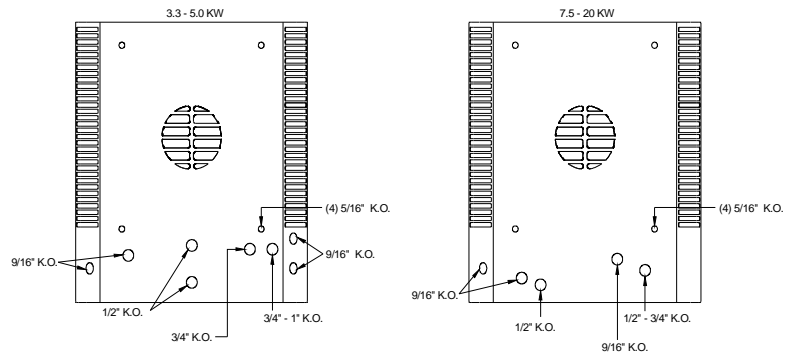

* For vertical discharge mounting bracket
Diagrams not to scale

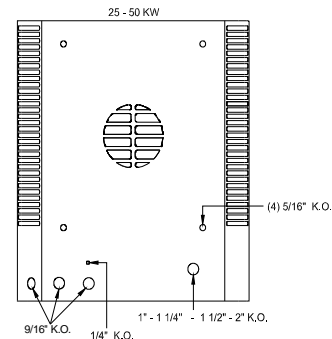

NET JUNCTION BOX VOLUME		
KW	CUBIC INCHES	CC
3.3 - 5	74.4	1219
7.5 - 10	198	3245
15.0 - 20	198	3245
25.0 - 50	341	5592

INSTALLATION INSTRUCTIONS

TASKMASTER -- 5100 SERIES UNIT HEATER (part 2)

HORIZONTAL -- AIR DISCHARGE MOUNTING SHOWN IN: FIGURE 5 & 6

Swivel hanger brackets may be used to suspend unit heaters from either the wall (figure 5) or the ceiling (figure 6). Attach hanger base "A" to top of heater with the four 5/16 X 18 caps screws and lockwashers (provided in envelope).

Attach main hanger frame "B" to wall or ceiling in desired location using lag screws "C" or other suitable attachments (supplied by others).

Lift heater into position inserting stud "D" through hole in main hanger frame and attach lock nut "provided in envelope) "E" tightening to within two turns of being tight.

Swivel heater to desired position, tighten lock nut.

Figure 5
WALL MOUNT
HORIZONTAL DISCHARGE

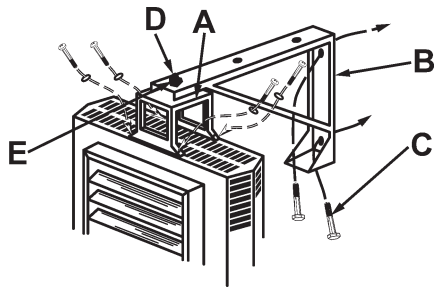
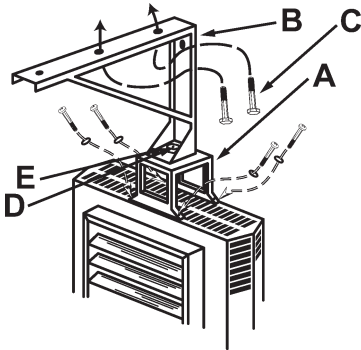

Figure 6
CEILING MOUNT
HORIZONTAL DISCHARGE



VERTICAL -- AIR DISCHARGE MOUNTING SHOWN IN: FIGURE 7

Attach short angle brackets "A" to back of heater with four 5/16 X 18 capscrews "B", lockwashers "F". Be sure vertical leg of angle brackets face top and bottom of heater.

Attach inverted U frames "D" to short angle brackets with four 5/16 X 18 capscrews "K", washers "L", lockwashers "M" and nuts "N".

Attach long angle brackets "J" to inverted frames "D" with four 5/16 X 18 capscrews "K", washers "L", lockwashers "M" and nuts "N".

Attach heater and bracket assembly to ceiling in desired location using customer supplied equipment sufficient to support the assembly.

Figure 7
CEILING MOUNT
VERTICAL DISCHARGE

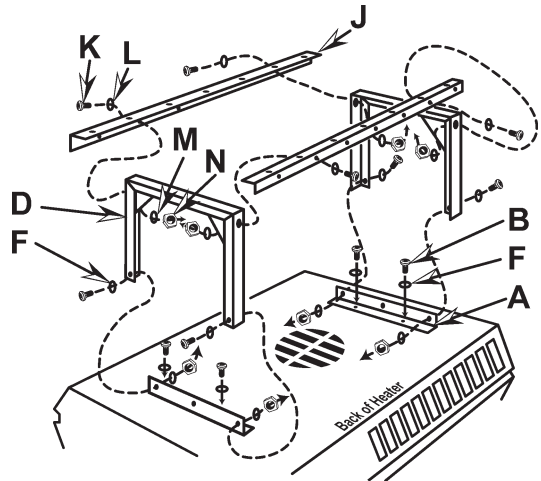

NOTE: When mounting heater using 5/16" all thread rod (by others) do not screw the rod more than 1/2" beyond the inside of the case.

5100 SERIES UNIT HEATER ELECTRICAL DATA (Table 2)

CATALOG NUMBER	KW RATING	BTU/HR (000)	HEATER / MOTOR VOLTAGE	HEATER PHASE	CONTROL VOLTAGE	AMPS PER PHASE	BRANCH CIRCUIT PROTECTION SIZE(A)	SUPPLY WIRE SIZE 60° C AWG **
F1F5130	3.3	11.2	208	1	208	15.9	20	12
F2F5130	3.3	11.2	208	1	208	15.9	20	12
			208	3	208	9.2	15	14
HF1B5103	3.3/2.5	11.2/8.5	240/208	1	240/208	13.7/11.9	20/15	12/14
HF2B5103	3.3/2.5	11.2/8.5	240/208	1	240/208	13.7/11.9	20/15	12/14
			240/208	3	240/208	7.9/6.9	10/10	14/14
G1G5103	3.3	11.2	277	1	277	11.9	15	14
P3P5103CA1	3.3	11.2	480	3	24	4	15	14
F1F5105	5.0	17.1	208	3	208	24.1	35	8
F2F5105	5.0	17.1	208	1	208	24.1	35	8
F2F5105	5.0	17.1	208	1	208	24.1	35	8
			208	1	208	24.	35	8
HF1B5105	5.0/3.7	17.1/12.8	240/208	1	240/208	20.9/18.1	30/25	10/10
HF2B5105	5.0/3.7	17.1/12.8	240/208	1	240/208	20.9/18.1	30.25	10/10
			240/208	3	240/208	12.1/10.4	20/15	12/14
G1G5105	5.0	17.1	277	1	277	18.1	25	10
P3P5105CA1	5.0	17.1	480	3	24	6.1	15	14
F2F5107CA1	7.5	25.6	208	1	24	36.1	50	6
			208	3	24	20.8	30	10
HF2B5107CA1	7.5/5.6	25.6/19.2	240/208	1	24	31.3/27.1	40/35	8/8
			240/208	3	24	18.1/15.6	25/20	10/12
G1G5107CA1	7.5	25.6	277	1	24	27.1	35	8
P3P5107CA1	7.5	25.6	480	3	24	9.1	15	14
			208	3	24	27.8	35	8
HF2B5110CA1	10.0/7.5	34.1/25.6	240/208	1	24	41.6/36.1	60/50	4/6
			240/208	3	24	24/20.8	30/30	8/10
G1G5110CA1	10.0	34.1	277	1	24	36.1	50	6
P3P5110CA1	10.0	34.1	480	3	24	12.1	20	12
F3F5115CA1	15.0	51.2	208	3	24	41.7	60	4
HF3B5115CA1	15.0/11.2	51.2/38.4	240/208	3	24	36.1/31/3	50/40	6/8
P3P5115CA1	15.0	51.2	480	3	24	18.1	25	10
HF3B5120CA1	19.5/14.6	67.2/50.5	240/208	3	24	47.8/41.1	60/60	4/6
P3P5120CA1	20.0	68.3	480	3	24	24.1	35	8
F3F5125CA1	25.0	83.3	208	3	24	69.5	90	2
HF3B512CA1	25.0/18.7	85.3/64.0	240/208	3	24	60.2/52.1	80/70	3/4
P3P5125	25.0	85.3	480	3	24	30.1	40	8
F3F5130CA1	30.0	102.4	208	3	24	83.4	110	2*
HB3B5130CA1	30.0/22.5	102.4/76.8	240/208	3	24	72.3/62.5	100/80	2/3
P3P5130CA1	30.0	102.4	480	3	24	36.2	50	6
F3F5140CA1	40.0	136.5	208	3	24	111.2	150	1/0*
HF3B5140CA1	40.0/30.0	136.5/102.4	240/208	3	24	96.4/83.4	124/110	1*/2*
P3P5140CA1	39.0	133.1	480	3	24	47	60	4
F3F5150CA1	49.6	169.9	208	3	24	139	175	2/0*
HF3BB5150CA1	50.0/37.5	170.6/128.0	240/208	3	24	120.5/104.3	175/150	2/0* 1/0*
P3P5150CA1	50.0	170.6	480	3	24	60.3	80	3
U3H5105CA4***	5.0	17.1	600/240	3	240	5.1	15	14
U3H5107CA4	7.5	25.6	600/240	3	240	7.7	15	14
U3H5110CA4	10.0	34.1	600/240	3	240	10.2	15	14
U3H5115	15.0	51.2	600/240	3	240	15.5	20	12
U3H5120CA4	20.0	68.3	600/240	3	240	20.3	25	10
U3H5125CA4	25.0	85.3	600/240	3	240	24.5	35	8
U3H5130CA4	30.0	102.4	600/240	3	240	29.4	40	8
U3H5140CA4	40.0	136.5	600/240	3	240	39.8	50	6
U3H5150CA4	50.0	170.0	600/240	3	240	49.4	60	4
T3H5105CA4N	5.0	17.1	550/240	3	240	5.25	15	14
T3H5107CA4N	7.5	25.6	550/240	3	240	7.88	15	14
T3H5110CA4N	10.0	33.8	550/240	3	240	10.5	15	14
T3H5115CA4N	15.0	51.2	550/240	3	240	15.76	20	12
TEH5120CA4N	20.0	68.3	550/240	3	240	21.1	30	10
T3T5125CA1N	25.0	85.3	550	3	24	26.3	35	8
T3T5130CA1N	30.0	102.4	550	3	24	31.5	40	8
T3T5140CA1N	40.0	136.5	550	3	24	42	60	4
T3T5150CA1N	50.0	170.6	550	3	24	52.55	70	4

* Use 75 degree C Wire

**Use Copper Conductors on all heaters

***This unit (only) built in 7.5 & 110KW case size.

5100 SERIES UNIT HEATER

AIR DELIVERY DATA

FAN MOTOR DATA

CFM at OUTLET	FPM at OUTLET	TEMPETURE RISE °F	HP	Motor RPM	MAX. MTG		AIR THROW	WEIGHT LBS.
					Horizontal	Vertical		
400	1030	26	1/125	1550	9	9	12 Ft.	25
400	1030	26	1/125	1550	9	9	12 Ft.	25
400	1030	26	1/125	1550	9	9	12 Ft.	25
400	1030	26	1/125	1550	9	9	12 Ft.	25
400	1030	26	1/125	1550	9	9	12 Ft.	25
400	1030	26	1/125	1550	9	9	12 Ft.	27
400	1030	40	1/125	1550	9	9	12 Ft.	25
400	1030	40	1/125	1550	9	9	12 Ft.	25
400	1030	40	1/125	1550	9	9	12 Ft.	25
400	1030	40	1/125	1550	9	9	12 Ft.	25
400	1030	40	1/125	1550	9	9	12 Ft.	25
400	1030	40	1/125	1550	9	9	12 Ft.	25
400	1030	40	1/125	1550	9	9	12 Ft.	27
700	1000	34	1/50	1550	10	12	22 Ft.	50
700	1000	34	1/50	1550	10	12	22 Ft.	50
700	1000	34	1/50	1550	10	12	22 Ft.	50
700	1000	34	1/50	1550	10	12	22 Ft.	50
700	1000	45	1/50	1550	10	14	22 Ft.	50
700	1000	45	1/50	1550	10	14	22 Ft.	50
700	1000	45	1/50	1550	10	14	22 Ft.	50
700	1000	45	1/50	1550	10	14	22 Ft.	50
700	1000	45	1/50	1550	10	14	22 Ft.	50
700	1000	45	1/50	1550	10	14	22 Ft.	50
1100	1580	43	1/20	1550	11	20	32 Ft.	65
1100	1580	43	1/20	1550	11	20	32 Ft.	65
1100	1580	43	1/20	1550	11	20	32 Ft.	65
1100	1580	57	1/20	1550	11	20	32 Ft.	65
1100	1580	57	1/20	1550	11	20	32 Ft.	65
2000/1800	1300/1100	40/44	1/12	1550/1250	12	22	45 Ft.	120
2000/1800	1300/1100	40/44	1/12	1550/1250	12	22	45 Ft.	120
2000/1800	1300/1100	40/44	1/15	1550/1250	12	22	45 Ft.	120
2000/1800	1300/1100	47/53	1/12	1550/1250	12	20	40 Ft.	120
2000/1800	1300/1100	47/53	1/12	1550/1250	12	20	40 Ft.	120
2000/1800	1300/1100	47/53	1/15	1550/1250	12	20	40 Ft.	120
3100/2800	2000/1800	40/45	1/4	1550/1310	15	25	55 Ft.	120
3100/2800	2000/1800	40/45	1/4	1550/1310	15	25	55 Ft.	120
3100/2800	2000/1800	40/45	1/4	1550/1310	15	25	55 Ft.	120
3100/2800	2000/1800	51/56	1/4	1550/1310	15	22	50 Ft.	120
3100/2800	2000/1800	51/56	1/4	1550/1310	15	22	50 Ft.	120
3100/2800	2000/1800	51/56	1/4	1550/1310	15	22	50 Ft.	120
558	929	30	1/125	1300	9	9	12 Ft.	50
700	1000	34	1/50	1550	10	12	22 Ft.	50
700	1000	45	1/50	1550	10	14	22 Ft.	50
1100	1580	43	1/20	1550	11	20	32 Ft.	65
1100	1580	43	1/20	1550	11	20	32 Ft.	65
2000/1800	1300/1100	40/44	1/12	1550/1250	12	22	45 Ft.	120
2000/1800	1300/1100	47/53	1/12	1550/1250	12	22	40 Ft.	120
3100/2800	2000/1800	40/45	1/4	1550/1310	15	25	55 Ft.	120
3100/2800	2000/1800	51/56	1/4	1550/1310	15	22	50 Ft.	120
680	971	25.1	1/125	1300	9	9	12 Ft.	50
680	971	37.6	1/50	1550	10	12	22 Ft.	50
680	971	50.2	1/50	1550	10	14	22 Ft.	50
1080	1542	47.4	1/20	1550	11	20	32 Ft.	65
1080	1542	63.2	1/20	1550	12	18	37 Ft.	65
1980/1780	1290/1150	43/48	1/12	1550/125	12	22	45 Ft.	120
1980/1780	1290/1150	52/58	1/12	1550/125	12	20	40 Ft.	120
2900/2650	1870/1160	47/52	1/4	1550/131	15	25	55 Ft.	120
2900/2650	1870/1160	59/66	1/4	1550/131	15	22	50	120

5100 SERIES UNIT HEATER TROUBLE SHOOTING GUIDE

SYMPTOM	POSSIBLE CAUSE(S)	CORRECTIVE ACTION
Thermostat calls for heat, but heater does not function.	<ol style="list-style-type: none"> 1. Open (blown) fuse 2. INCORRECT WIRING 3. Thermal cut-out open, deenergizing heater element and control circuit. 	<ol style="list-style-type: none"> 1. Replace fuses, check for cause. (see Replacement Parts List for fuse size) 2. CHECK WIRING CONNECTIONS 3. Check for the following: <ul style="list-style-type: none"> --- Correct supply volts and phase --- Correct control wiring (heater control must be thru thermostat control wiring section only). --- Power interruption to heater during heater operation. --- Restriction of air around heater 1-5 minute fan purge after thermostat off.
Fan motor runs "HOT"	<ol style="list-style-type: none"> 1. Dust accumulation or excessive dirt on motor 2. Dirt accumulation 3. Motor needs lubrication. 	<ol style="list-style-type: none"> 1. Clean fan motor and casing of grease and oil accumulation. 2. Clean louvers and between heating elements. 3. See Maintenance.
Fan motor runs, but no heat.	<ol style="list-style-type: none"> 1. Element contactor not operating correctly. 2. Element fuse blown. 	<ol style="list-style-type: none"> 1. Check wiring for open circuit. Replace contactor if defective 2. Replace fuses, check for cause. (see Replacement Parts List for fuse size)

MAINTENANCE

CAUTION: Make certain that the power source is disconnected before attempting to service or disassemble any componet. If the power disconnect is out of the line of sight, lock it in the OPEN position and tag to prevent the application of power.

ELECTRICAL

Once a year inspect the control panel wiring to make certain insulation is intact and all connections are tight. Inspect all heater and relay contacts. If the contacts appear badly pitted or burned, replace the contactor / relay.

CLEANING

Clean the unit casing, fan and motor once a year. A dirty motor will tend to run hot and eventually will be damaged internally. Any rust spots on the casing should be cleaned and repainted.

LUBRICATION

All units up to 20KW have fan motors that are permanently lubricated so that only occasional cleaning is required. Units above 20KW have fan motors lubricated for 5 years of continuous duty of 10 years of intermittent operations. When required, remove the oil access plug on back of heater at motor intake grill, open oil cap, fill with S.A.E. No. 10 electric motor oil, replace plugs and access plug.

5100 SERIES UNIT HEATER WIRING DIAGRAM SCHEDULE

DIAGRAM NO.	MODEL CODE PREFIX	MODEL CODE SIZE AND CONTROL SYSTEM		
WD5101	FIF-GIG-HFIB	5103N	5105N	
WD5104	GIG	5107CAIL	5110CAIL	
WD5106	F2F-HF2B	5103N	5105N	
WD5113	F2F	5107CAIL	5110CAIL	
WD5114	HF2B	5107CAIL	5110CAIL	
WD5138	P3P	5103CAIL	5105CAIN	5107CAIN
WD5121	P3P	5110CAIN	5115CAIN	5120CAIN
WD5122	F3F	5115CAIL		
WD5125	HF3B	5115CAIL	5120CAIL	
WD5126	F3F	5125CAIL	5130CAIL	5140CAIL
WD5126	F3F	5125CAIL	5130CAIL	5140CAIL
WD5126	HF3B	5125CAIL	5130CAIL	5140CAIL
WD5139	HF3B	5150CAIL		
WD5140	P3P, T3T	5125CAIN	5130CAIN	
WD5140	P3P	5140CAIN		
WD5141	P3P	5150CAIN		
WD5142	U3H, T3H	5105CA4N	5107CA4N	5110CA4N
WD5142	U3H, T3H	5115CA4N	5120CA4N	
WD5143	U3H	5125CA4N	5130CA4N	5140CA4N
WD5143	U3H	5150CA4N		
WD5144	T3T	5140CAIN	5150CAIN	

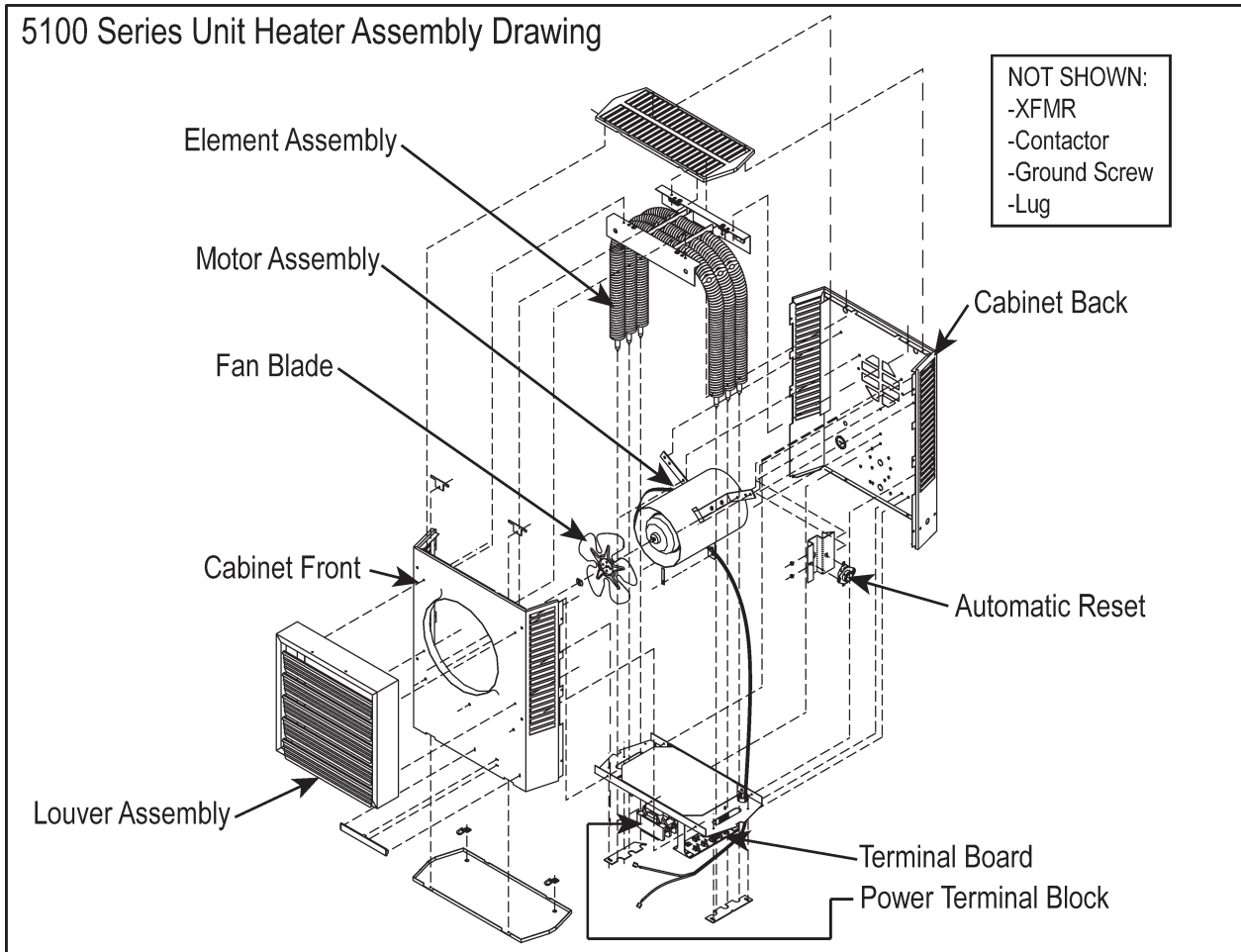

5100 SERIES UNIT HEATER PARTS LIST - CATALOG NUMBERS

HEATER MODEL	MOTOR	ELEMENT ASSEMBLY	AUTOMATIC RESET	FAN OVERRIDE	XFMR	CONTACTOR	POWER TERMINAL BLOCK
F1F5103N	56562-012	60715-001	57640-006	28163-005			56815-001
F25103N	56562-012	60715-011	57640-006	28163-005			56815-001
HF1B5103N	56562-017	60715-002	57604-006	28163-005			56815-001
HF2B5103N	56562-017	60715-012	57604-006	28163-005			56815-001
G1G5103N	56562-016	60715-007	57604-006	28163-005			56815-001
P3P5103CA1N	56562-018	60715-008	57604-006	56811-001	60719-006	58027-041	56815-001
F1F5105N	56562-012	60715-003	57604-006	28163-005			56815-001
F2F5105N	56562-012	60715-004	57604-006	28163-005			56815-001
HF1B5105N	56562-017	60715-005	57604-006	28163-005			56815-001
HF2B5105N	56562-017	60715-006	57604-006	28163-005			56815-001
G1G5105N	56562-016	60715-009	57604-006	28163-005			56815-001
P3P5105CA1N	56562-018	60715-010	57604-006	56811-001	60719-006	58027-041	56815-001
F2F5107CA1L	56823-011	56954-004	57604-003	56811-001	60719-001	58027-031	56815-001
HF2B5107CA1L	56823-012	56954-006	57604-003	56811-001	60719-001	58027-021	56816-001
G1G5107CA1L	56824-002	56954-001	57604-003	56811-001	60719-005	58027-021	56815-001
P3P5107CA1N	56824-011	56954-002	57604-003	56811-001	60719-006	58027-041	56815-001
F2F5110CA1L	56823-011	56954-003	57604-003	56811-001	60719-001	58027-036	56816-001
HF2B5110CA1L	56823-012	56954-004	57604-003	56811-001	60719-001	58027-036	56816-001
G1G5110CA1L	56824-002	56954-007	57604-003	56811-001	60719-005	58027-031	56816-001
P3P5110CA1N	56824-011	56954-008	57604-003	56811-001	60719-006	58027-041	56815-001
F3F5115CA1L	56825-001	56954-009	57604-004	56811-001	60719-001	58027-036	56816-001
HF3B5115CA1L	56825-002	56954-010	57604-004	56811-001	60719-001	58027-031	56816-001
P3P5115CA1N	56825-003	56954-011	57604-004	56811-001	60719-006	58027-041	56815-001
HF3B5120CA1L	56825-002	56954-012	57604-004	56811-003	60719-001	58027-036	56816-001
P3P5120CA1N	56825-003	56954-013	57604-004	56811-003	60719-006	58027-041	56815-001

HEATER MODEL	MOTOR	ELEMENT ASSY.	AUTO. RESET	FAN OVERRIDE	XFMR	S.D. FUSE 6 RQD	S.D. FUSE 2 RQD	CONTACTOR 2 RQD	POWER TERMINAL BLOCK	FAN
F3F5125CA1L	56943-001	56954-017	57640-005	56811-002	60719-009	50836-012	41280-002	50378-025	57097-001	57112-001
HF3B5125CA1L	56943-002	56954-018	57640-005	56811-002	60719-009	50836-012	41280-007	50378-025	57097-001	57112-001
P3P512CA1N	56944-001	56954-019	57640-005	56811-002	60719-012			50378-016	57098-001	57090-001
F3F5130CA1L	56943-001	56954-020	57640-005	56811-002	60719-009	50836-003	41280-008	50378-025	57097-001	57112-001
HF3B5130CA1L	56943-002	56954-021	57640-005	56811-002	60719-009	50836-012	41280-002	50378-025	57097-001	57112-001
P3P5130CA1N	56944-001	56954-022	57640-005	56811-002	60719-012			50378-016	57098-001	57090-001
F3F5140CA1L	56945-001	56954-023	57640-005	56811-002	60719-009	50836-003	41280-004	50378-025	57097-001	57112-001
HF3B5140CA1L	56945-002	56954-024	57640-005	56811-002	60719-009	50836-003	41280-003	50378-025	57097-001	57112-001
P3P5140CA1N	56946-001	56954-025	57640-005	56811-002	60719-012			50378-016	57098-001	57090-001
F3F5150CA1L	56945-001	56954-026	57640-005	56811-003	60719-009	50836-003	41280-005	50378-034	57097-001	57112-001
HF3B5150CA1L	56945-002	56954-027	57640-005	56811-003	60719-009	50836-003	41280-004	50378-025	57097-001	57112-001
P3P5150CA1N	56946-001	56954-028	57640-005	56811-003	60719-012	57110-001	57111-008	50378-016	57097-001	57090-001

KW	FAN BLADE	TERMIAL BOARD	GROUND CONN.	MOTOR CAPACITOR	LOUVER
3.3 - 5	56806-001	56809-001	1458	--	(5) 56986-001
7.5 - 10	50551-002	56809-001	1458	--	(7) 56986-003
15 - 20	56813-001	56809-001	1458	--	(7) 56986-003
25 - 30	57114-001	56809-001	3981	57100-001	(9) 56987-001
40 - 50	57115-001	56809-001	3981	57100-001	(9) 56987-001

5100 SERIES UNIT HEATER

PARTS LIST - CATALOG NUMBERS - 600 VOLT MODELS

	U3H5105CA4N	U3H5107CA4N	U3H5110CA4N	U3H5115CA4N	U3H5120CA4N
MOTOR	56562-017	56823-012	56823-012	56825-002	56825-002
ELEMENT ASSY.	56954-029	56954-030	56954-031	56954-032	56954-035
AUTO RESET LIMIT	57640-003	57640-003	57640-003	57640-004	57640-004
FAN OVERRIDE	56811-001	56811-001	56811-001	56811-001	56811-003
XFMR	57641-003 (100VA)	57641-001 (150VA)	57641-001	57641-002 (300VA)	57641-002
CONTACTOR	58027-043	58027-043	58027-043	58027-043	58027-043
POWER TRML. BLOCK	56817-001	56815-001	56815-001	56815-001	56815-001
FAN BLADE	51554-002	51554-002	51554-002	56813-001	56813-001
TERMINAL BLOCK	56809-001	56809-001	56809-001	56809-001	56809-001
GROUND CONN.	1458	1458	1458	1458	1458
LOUVER	56986-003 (7)	56986-003 (7)	56986-003 (7)	56986-003 (7)	56986-003 (7)
	U3H5125CA4N	U3H5130CA4N	U3H5140CA4N	U3H5150CA4N	
MOTOR	56943-002	56943-002	56943-002	56945-002	
ELEMENT ASSY.	56954-003	56954-003	56954-036	56954-037	
AUTO. RESET LIMIT	57640-005	57640-005	57640-005	57640-005	
FAN OVERRIDE	56811-002	56811-002	56811-002	56811-003	
XFMR	57641-001	57641-001	57641-004(350VA)	57641-004	
CONTACTOR	58027-043 (2)	58027-043 (2)	58027-043 (2)	58027-043 (2)	
POWER TRML. BLOCK	57098-001	57098-001	57098-001	57098-001	
FAN BLADE	57114-001	57114-001	57115-001	57115-001	
TERMINAL BOARD	56809-001	56809-001	56809-001	56809-001	
GROUND CONN.	3981	3981	3981	3981	
LOUVER	56986-004(9)	56896-004(9)	56986-004(9)	56986-004(9)	
XFMR PRI FUSE BLOCK	57643-001	57643-001	57643-001	57643-001	
XFMR PRI FUSE (2)	57644-001 (2)	57644-001 (2)	57644-001 (2)	57644-001 (2)	
FAN SPEED SW	57112-001	57112-001	57112-001	57112-001	
MOTOR CAPACITOR	57100-001	57100-001	57100-001	57100-001	
	T3H5105CA4N	T3H5107CA4N	T3H5110CA4N	T3H5115CA4N	T3H5120CA4N
MOTOR	56562-017	56823-012	56823-012	56815-002	56825-002
ELEMENT ASSY.	56954-061	56954-054	56954-055	56954-056	54929-006
FAN OVERRIDE	66811-001	56811-001	56811-001	56811-001	56811-001
XFMR	57641-003	57641-003	57641-001	57614-002	57641-002
CONTACTOR	58027-043	58027-043	58027-043	58027-043	58027-043
POWER TRML. BLOCK	56815-001	56815-001	56815-001	56815-001	56815-001
FAN BLADE	51554-002	51554-002	51554-002	56813-001	56813-001
TERMINAL BOARD	56809-001	56809-001	56809-001	56809-001	56809-001
GROUND CONN.	1458	1458	1458	1458	1458
LOUVER	56986-003(7)	56986-003(7)	56986-003(7)	56986-003(7)	56986-003(7)
	T3T5125CA1N	T3T5130CA1N	T3T5140CA1N	T3T5150CA1N	
MOTOR	56943-002	56943-002	56945-002	56945-002	
ELEMENT ASSY.	56954-057	56954-058	56954-059	56954-060	
AUTO RESET LIMIT	57640-005	57640-005	57640-005	57640-005	
FAN OVERRIDE	56811-002	56811-002	56811-002	56811-002	
XFMR	60719-018	60719-018	60719-018	60719-018	
CONTACTOR	58027-043 (2)	58027-043 (2)	58027-043 (2)	58027-043 (2)	
POWER TRML. BLOCK	57098-001	57098-001	57098-001	57098-001	
FAN BLADE	57114-001	57114-001	57114-001	57114-001	
TERMINAL BOARD	56809-001	56809-001	56809-001	56809-001	
GROUND CONN.	3981	3981	3981	3981	
LOUVER	56986-004 (9)	56986-004 (9)	56986-004 (9)	56986-004 (9)	
FAN SPEED SWITCH	57112-001	57112-001	57112-001	57112-001	
MOTOR CAPACITOR	57100-001	57100-001	57100-001	57100-001	

LIMITED WARRANTY

Products manufactured by TPI Corporation are warranted to the original consumer to be free from defects in material and workmanship for twelve (12) months from the original purchase date.

The TPI limited warranty does not cover products that have been modified outside of our factory, damage or failure caused by acts of God, abuse, misuse, connected to or placed on other than rated voltage, abnormal usage, fault, installation, failure to follow suggested maintenance procedures enclosed with the product, improper maintenance or any repairs other than those provided by an authorized TPI service center.

There are no obligations or liabilities on the part of the Corporation for consequential damages arising out of or in connection with the use or performance of the product or other indirect damages with respect to loss of property, revenues, profit, costs of removal installation, or reinstallation.

All implied warranties with respect to TPI products, including implied warranties for merchantability and implied warranties for fitness, are limited in duration to twelve (12) months from original date of purchase, except those products or parts of products which are warranted for long periods. On such products or parts of products all implied warranties for merchantability and fitness are limited to the duration of the extended warranty period thereon.

Some states do not allow the exclusions or limitation of incidental or consequential damages and some states do not allow limitations on how long an implied warranty lasts. The above exclusions or limitations may not apply to you.

During the warranty period, TPI Corporation will, at its sole option, repair or replace any defective parts or products returned, freight prepaid, to the TPI Corporation factory or such other locations as TPI Corporation may designate. Returned products must be packaged carefully and TPI Corporation shall not be responsible for damage in transit.

When returning parts, the owner must provide the model number of the product and nature of difficulty being experienced. This warranty does not obligate TPI Corporation to bear the cost of labor in replacing any assembly, unit or component part thereof, nor does the company assume any liability for secondary charges, expenses for installing or removal, freight or damages. There will be charges rendered for product repairs made after the warranty period has expired. Proof of purchase, including date, must accompany request for in-warranty service. In any event, TPI Corporation's maximum liability shall not in any case exceed the list price for the product claimed to be defective. This warranty gives to you specific legal rights and you may have other rights, which may vary from state to state. For the name of your nearest authorized TPI Corporation service center, please write to TPI Corporation, P.O. Box 4973, Johnson City, TN 37602.

Heating Products Warranty Coverage

Elements in 198 Series Portable	Life of heater
Elements in Baseboards	10 Years
All Other Heating Products	1 Year
Thermostats and Controls	2 Years

Ventilation Products Warranty Coverage

Series HD or HDH Fans	5 Years
Series UHP or IHP Fans	3 Years
All other Ventilation Products	1 Year



TPI Corporation
P.O. Box 4973
Johnson City, TN
37602-4973

America's Comfort Conditioning Company

TASKMASTER

5100 SERIES

INSTALLATION INSTRUCTIONS & PARTS LIST

Montage horizontal ou vertical
radiateur industriel et commercial

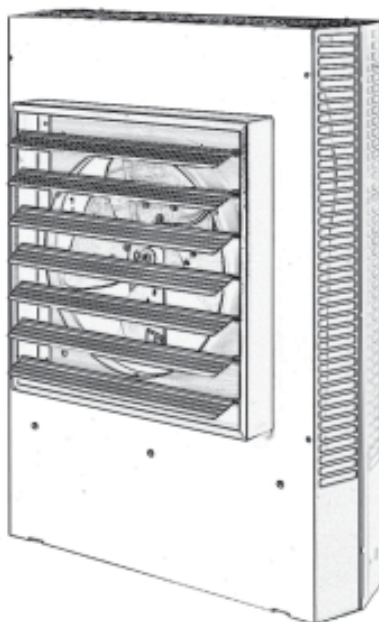
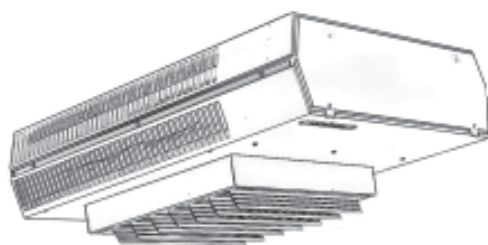

TPI Corporation
P.O. Box 4973
Johnson City, TN
37602-4973

America's Comfort Conditioning Company

ATTENTION: Lisez les instructions soigneusement avant de commencer l'installation, la mise en marche ou l'entretien du radiateur taskmaster. Gardez ces instructions pour utilisation ulterieure.

CARACTERISTIQUES

Radiateur electrique ventilateur, disponible suivant les tensions standards de 208, 240/208, 277, 480 ou de 600 volts.

Dix puissances de chauffage standard de 3.3 KW/11,260 BTUH jusqu' a 50.0 KW/170, 600 BTUH.

Les modeles unipolaires de 3.3 jusqu a 10.0 Kw de 240/208 volts peuvent se transformer sur le chantier en modele tripolaire. (Les modeles uipolaires de 3.3, 5.0, 7.5 et 10 Kw de 277 volts ne peuvent etre transformes).

Le volet interieur specialement concu permet au ventilateur d'appeler l'air uniformement a travers l'element massif en acier.

Le diffuseur concu vers l'exterieur et les volets montes dirigent plug encore uniformement la propulsion de l'air afin de repondre aux exigences specifiques du montage horizontal ou vertical de l'appareil.

Supports de montage mur/lafond ou verticaux en option. (comme requis).

Quatre ecrous soudes sont disposes au dessus et a l'arriere du boitier pour le montage de l'appareil au chantier avec des tiges filetees ou des boulons avec chaine. (visserie fournie par d'autres).

Diffuseur anemostat ou radial (en option), donnant une population d'air diversifiee lors du montage vertical de l'appareil.

Instruments de controle varies pour installation sur le chantier. Interrupteur, thermostat, interrupteur du ventilateur pour la saison estivale, thermostat pour recu peration de chaleur. Tous ont leurs conducteurs equipes de serre-fils a lame. (a l'exception de l'interrupteur).

Tableau de branchement de la filerie de tous les instruments de controle integres, en un seul endroit.

Circuit de controle standard basse tension de 24 volts sur tous les modeles avec transformateur ou contracteur.

Boite de controle spacieuse ayant une porte d'accès fermee a l'aide de deux attaches 1/4 de tour pour rendre l'intallation facile.

INSTRUCTIONS D'ENDROIT NÉCESSAIRES

Dès que la charge totale de chauffage est calculée, la quantité et la capacité des chauffages d'unité doivent être déterminés. parce qu'un grand nombre de chauffages de capacité basse fournit la distribution de chaleur plus uniforme. Cette approche est recommandée quand la région sera occupée par un relativement grand nombre de personnel sédentaire, (c'est-à-dire travaillant des chaînes de fabrication et aux bancs.)

Un grand nombre de plus petits chauffages d'unité de capacité a tendance à prévenir des brouillons chauds, réduit des niveaux bruyants et augmente la diversité de charge pour aider à réduire la demande électrique et les frais d'exploitation.

Dans les magasins où chauffent même la distribution et les températures constantes sont moins importants, un plus petit nombre de hautes unités de capacité peut être utilisé - dans beaucoup de cas réduisant le prix d'installation. Pour maintenir la distribution de chaleur raisonnable et réduire la stratification sévère même dans les régions de baie plus basses, le volume aérien total de l'espace devrait traverser les chauffages d'unité environ trois fois par heure. (Prenez des pieds cubiques totaux et la division par 20 déterminent afin du chauffage total nécessaire l'estimation de CFM.)

Il est important que le voltage évalué de l'équipement chauffant correspond au voltage de réserves. Le voltage de réserves plus du voltage estimé du chauffage peut nuire à l'équipement. Le voltage de réserves plus bas que le voltage de chauffage évalué diminuera la production de chauffage aussi bien que courra le risque de nuire à quelques composantes.

Les chauffages d'unité horizontaux sont recommandés dans les régions de baie basses avec les plafonds de 15 à 18 pieds maximums. Ceux-ci devraient être concentrés le long du mur extérieur ou d'autres régions de la plus grande perte de chaleur; espacé monter un mouvement aérien généralement circulaire, chaque chauffage soutenant le courant atmosphérique de l'autre. Supplémentaire vertical en bas au-dessous des chauffages d'unité avec diffuseurs auxiliaire approprié peut être trouvé pour contrer des pertes de chaleur de plafond (voir le chiffre 1 des graphiques d'Endroit).

Instructions d'Endroit du chiffre 1

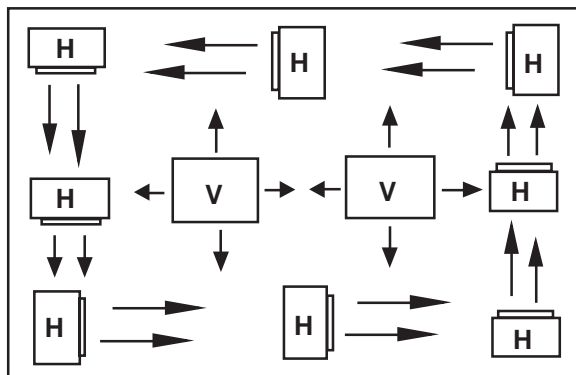

Général SAFETY INFORMATION / PRUDENCE :

Suivez tout l'habitant d'origine électrique et les codes de sécurité, aussi bien que le Code Électrique national (NEC) et l'acte de Santé et de Sécurité du Métier (OSHA).

Pour éviter le choc électrique possible, soyez sûrs que le courant électrique est éteint au changement principal avant de télégraphier ou assurer l'entretien de l'unité.

Si le pouvoir débranche n'est pas intrinsèque et est hors de vue, la serrure cela dans la position ouverte et l'étiquette pour prévenir l'application inattendue de pouvoir avant d'exécuter n'importe quel service ou maintenance de l'unité.

L'unité quand installé doit être électriquement fondée conformément à la pratique d'industrie Codée et standard Électrique nationale

Vérifiez que la source de pouvoir conforme aux exigences de votre équipement. Voir la Table 2 sur la page 6 pour la grandeur de circuit et le fil

Vérifiez le voltage de chauffage et la phase en estimation de l'étiquette pour confirmer qu'il correspond aux réserves de service électriques.

Les schémas de connexions du chauffage et des connexions de réserves sont attachés en permanence à l'intérieur de la bouche d'accès de chauffage. Tous les terminus sont codés conformément au schéma de connexions. L'installation électrique auxiliaire est montrée sur le schéma de connexions d'unité et la littérature de soutien.

Le chauffage doit être monté au moins 7' au-dessus de l'étage pour prévenir le contact accidentel avec la lame de fan qui pourrait provoquer la blessure. Installez l'unité ainsi il n'y a aucune obstruction pour la consommation ou le renvoi. Maintenez des déblayages comme montré sur la Table 1, 2, la Figure 1 et 2.

Le mur/plafond montant la structure et ancrant des provisions doit être sur la force suffisante pour soutenir le poids combiné du chauffage et du support de fixation.

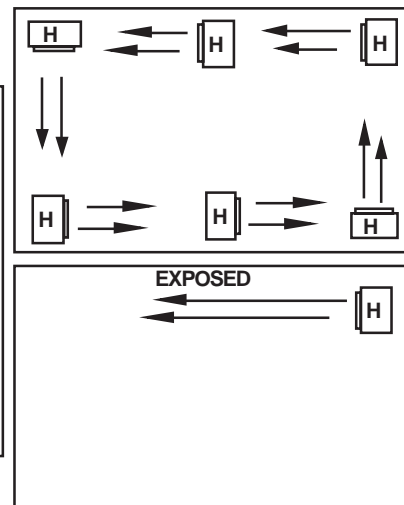

TASKMASTER

5100 SERIES

55 THRU 100 kW MODELS

Horizontal or Vertical Mounting
Industrial / Commercial
Unit Heater

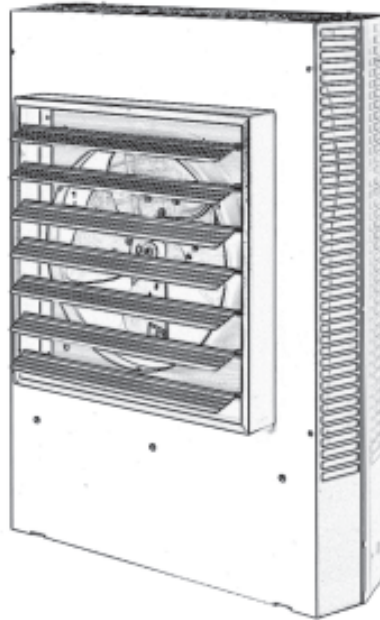

INSTALLATION INSTRUCTIONS & PARTS LIST



TPI Corporation
P.O. Box 4973
Johnson City, TN
37602-4973

America's Comfort Conditioning Company

ATTENTION: Read carefully before attempting to install, operate or service the TaskMaster Unit Heater. Retain these installation instructions for future use.

PRODUCT FEATURES

Forced air electric unit heater available in 208, 240/208, and 480 volt, 3 phase as standard.

Ten standard heating capacities of 55.0 KW/187,715 BTUH thru 100.0 KW/341,300 BTUH.

Specially designed inlet louver allows the fan to pull cool air evenly across the high mass all-steel element.

Outward drawn venturi and adjustable louver assembly further directs the outlet air in a uniform pattern to meet specific air pattern requirements in either the horizontal or vertical mounting position.

Optional wall/ceiling or vertical mounting brackets (as required).

Four position weld nuts supplied in case top and back for field mounting by threaded rods or eye bolt with chain. (Hardware supplied by others).

Optional radial or anemostat diffusers lending air pattern

versatility when mounted vertically. (55 thru 75 kW only)

Modular control kits for field installation. Thermostat, summer fan switch, heat recovery thermostat. All kits with spade terminals .

Single point terminal board wiring of integral control kits.

24 volt low voltage control circuit standard on all models.

Roomy control box with access door locked into position by two (2) 1/4 turn fasteners for ease of installation.

Revised 03/07
Form XXXX

IMPORTANT: OWNER SHOULD RETAIN THESE INSTRUCTIONS FOR FUTURE REFERENCE

PROPER LOCATION INSTRUCTIONS

Once the total heating load is calculated, the quantity and capacity of the unit heaters must be determined. because a large number of low-capacity heaters provides more uniform heat distribution. This approach is recommended when the area will be occupied by a relatively large number of sedentary personnel, (i.e. working on production lines and at benches.)

A large number of smaller capacity unit heaters tends to prevent hot drafts, reduces noise levels, and increases diversity of load to help reduce electrical demand and operating costs.

In warehouses where even heat distribution and constant temperatures are less important, a smaller number of high capacity units can be used -- in many cases reducing installation cost. To maintain reasonable heat distribution and reduce severe stratification even in lower bay areas, the total air volume of the space should pass through the unit heaters about three times per hour. (Take total cubic feet and divide by 20 in order to determine proper total heater CFM rating.)

It is important that the rated voltage of the heating equipment match the supply voltage. Supply voltage in excess of the heater rated voltage can damage equipment. Supply voltage lower than the rated heater voltage will decrease heater output as well as run the risk of damaging some components.

Horizontal unit heaters are recommended in low bay areas with maximum 15 to 18 foot ceilings. These should be concentrated along outside wall or other areas of greatest heat loss; spaced to set up a generally circular air movement, each heater supporting the air stream of the other. Additional vertical down below unit heaters with appropriate accessory diffusers can be located to counteract ceiling heat losses (see Figure 1 Location charts).

Figure 1 Location Instructions

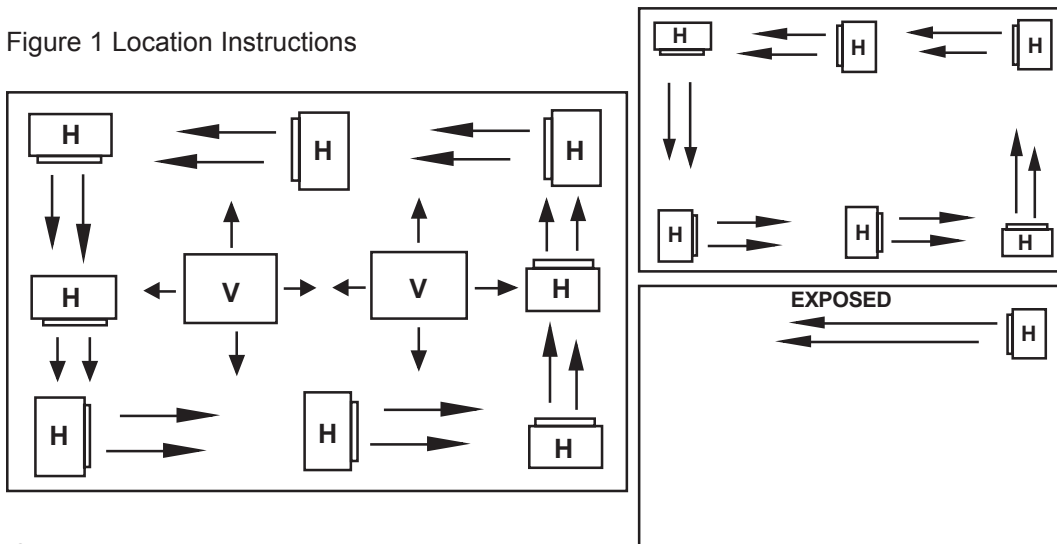

GENERAL SAFETY INFORMATION / CAUTION:

Follow all local electrical and safety codes, as well as the National Electrical Code (NEC) and the Occupational Safety and Health Act (OSHA).

To avoid possible electrical shock, be sure the electrical current is turned off at the main switch prior to wiring or servicing of unit.

If the power disconnect is not integral and is out-of-sight, lock it in the open position and tag to prevent unexpected application of power prior to performing any service or maintenance of the unit.

The unit when installed must be electrically grounded in accordance with the National Electrical Code and standard industry practice.

Make certain that the power source conforms to the requirements of your equipment. See Table 2 on page 6 for wire and circuit size

Check heater voltage and phase on rating label to confirm that it matches the electric service supply.

Wiring diagrams of the heater and supply connections are permanently attached to the inside of the heater access door. All terminals are coded in accordance with the wiring diagram. Accessory wiring are shown on the unit wiring diagram and supporting literature.

The heater must be mounted at least 7' above the floor to prevent accidental contact with the fan blade which could cause injury. Install unit so there are no obstructions to the intake or discharge. Maintain clearances as shown on Table 1, 2, Fig. 1 & 2.

The wall/ceiling mounting structure and anchoring provisions must be on sufficient strength to support the combined weight of the heater and mounting bracket.

PRINCIPLES OF OPERATION

Upon a call for heat from the floor level or unit mounted optional accessory thermostat, the unit fan motor and heating elements shall be energized and remain ON until temperature reaches setting of thermostat; at which time the heating elements shall be deenergized.

The fan motor shall continue to run and purge heater casing of residual heat until setting of fan override is reached, then the fan motor shall be deenergized.

All units are supplied with a single speed motor. The 55-75 kW heaters are supplied with 3 stages of heat. The heater can be wired as one stage, two stage or three stage. The 80 thru 100 kW models are supplied with four stages and be operated as 1 thru 4 stages. The thermostat or step controller (optional) will, upon a call for heat, energize fan motor and the first stage heating element. Should temperature continue to fall, the thermostat shall energize the remaining stages according to demand.

Upon a rise in space conditions towards setting of the thermostat or step controller, the stages of heating elements shall be deenergized in reverse sequence.

The fan motor shall continue to run and purge heater casing of residual heat until setting of fan override is reached, then the fan motor shall be deenergized.

The accessory unit mounted stratification thermostat will energize the unit heater fan motor upon a rise in temperature above its setting.

When the unit mounted stratification thermostat closes on a temperature rise and at the same time the floor thermostat calls for heat, the motor shall be energized immediately and the heating element shall be energized, as previously described.

The manual reset safety high limit shall deenergize the heating elements and control circuits should the temperature exceed the setting of this device. The fan safety override shall energize fan motor any time the setting of this device is exceeded so as to purge heater casing of excess residual heat.

When the accessory fan switch is placed in the ON position (for summer air circulation), the unit heater fan motor shall be energized.

NOTE: The wall thermostat is to be set to the OFF position during this mode of operation (units with contactors).

For those accessory thermostats equipped with an integral fan switch, place the switch in the HEAT, or AUTO position for operation of the fan and elements which shall then be under control of the thermostat as described above.

When switch is placed in the OFF position, the unit shall be deenergized. When switch is placed in the FAN position, elements shall be deenergized and fan shall be immediately energized.

VERTICAL DISCHARGE UNITS - AIR PATTERNS

USED ON	MAX MTG HT.	A	B	STOCK NO.	MAX MTG HT.	A	MAX MTG HT.	A	STOCK NO.	STOCK NO.	MAX MTG HT.		A	
											45°	OPEN	45°	OPEN
55 THRU 75 KW	--	--	--	STD	--	--	--	--	AD5175	RD 5175	--	--	--	--
80 THRU 100 KW	--	--	--	STD	--	--	--	--	N/A	N/A	--	--	--	--

STD = Standard N/A = Not Applicable

Optional diffusers lend added air pattern versatility to individual vertical down blow installations as shown in above illustrations.

INSTALLATION INSTRUCTIONS

TASKMASTER -- 5100 SERIES UNIT HEATER

ATTENTION: READ INSTRUCTION CAREFULLY

All electric unit heaters are shipped fully assembled. Installation includes hanging the unit, mounting the built-in and remote accessories, wiring of optional control devices, and electrical wiring to the unit.

To insure proper delivery of the heated air to desired areas, follow the mounting height and air projection tables include in these instructions. Follow Fig. 1 & 2 for minimum wall and ceiling clearances.

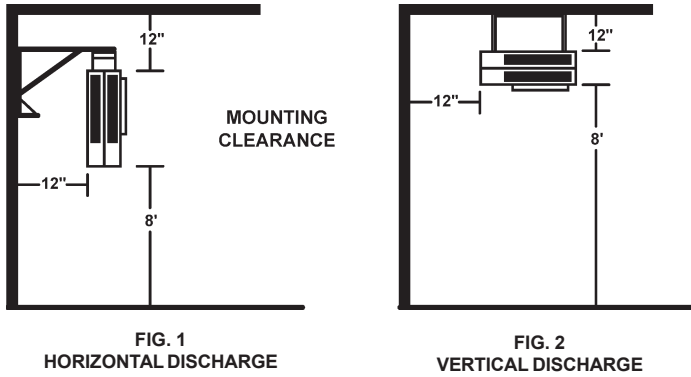

The wall and/or ceiling structure must be sufficient to support the combined weight of the heater and any mounting bracket and accessories.

Be sure power source is deenergized before installing heater. Check heater voltage and phase listed on heater date tape on back of unit to make sure they are the same as the electrical service supplied.

Units that carry a dual voltage rating (HF) require specific wiring changes when converting from 240 to 208 volt service supplied.

Open the access panel (2 1/4 turn fasteners).

Remove the desired knock-out(s) on back of the heater.

Install any optional accessories following their installation instructions before mounting unit. Following the correct unit/accessory wiring diagram, connect the power supply, electrical ground and accessories to the correct terminals or termination points using accepted practices.

Heaters may be mounted in the horizontal or vertical air discharge configuration using factory optional supplied accessory mounting equipment or using special hardware facilities supplied by others.

After the installation is complete, replace the access panel.

Set the controls (thermostat, switch) at their desired control point and apply power to the unit.

Check correct operation.

DIMENSIONS

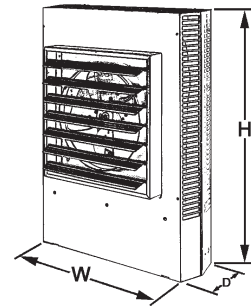

DIMENSIONS (INCHES)			
KW	H	W	D
55.0 - 75.0	35-1/2	30-1/2	14-1/2
80.0 - 100.0	39-1/2	37-5/8	18-1/2

**TYPICAL FOR
55 THRU 100 KW**

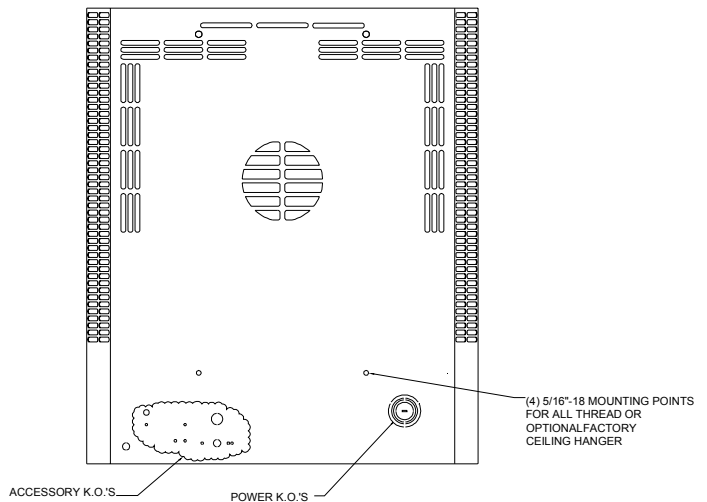

REAR OF UNIT SHOWN

INSTALLATION INSTRUCTIONS

TASKMASTER -- 5100 SERIES UNIT HEATER (part 2)

HORIZONTAL -- AIR DISCHARGE MOUNTING SHOWN IN: FIGURE 5 & 6

Swivel hanger brackets may be used to suspend unit heaters from either the wall (figure 5) or the ceiling (figure 6). Attach hanger base "A" to top of heater with the four 5/16 X 18 caps screws and lockwashers (provided in envelope).

Attach main hanger frame "B" to wall or ceiling in desired location using appropriate hardware or welding.

Lift heater into position inserting 5/8" bolt with lockwasher through hole in main hanger frame, tightening to welded nut on hanger base within two turns of being tight.

Swivel heater to desired position, tighten bolt.

Attach short angle brackets "A" to back of heater with four 5/16 X 18 capscrews "B", lockwashers "F". Be sure vertical leg of angle brackets face top and bottom of heater.

Attach inverted U frames "D" to short angle brackets with four 5/16 X 18 capscrews "K", washers "L", lockwashers "M" and nuts "N".

Attach long angle brackets "J" to inverted frames "D" with four 5/16 X 18 capscrews "K", washers "L", lockwashers "M" and nuts "N".

Attach heater and bracket assembly to ceiling in desired location using customer supplied equipment sufficient to support the assembly.

VERTICAL -- AIR DISCHARGE MOUNTING SHOWN IN: FIGURE 7

Figure 5
WALL MOUNT
HORIZONTAL DISCHARGE

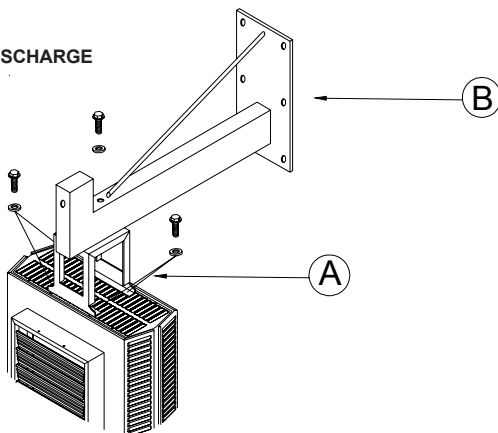

Figure 6
CEILING MOUNT
HORIZONTAL DISCHARGE

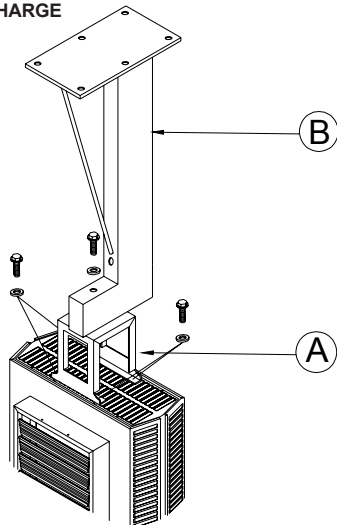
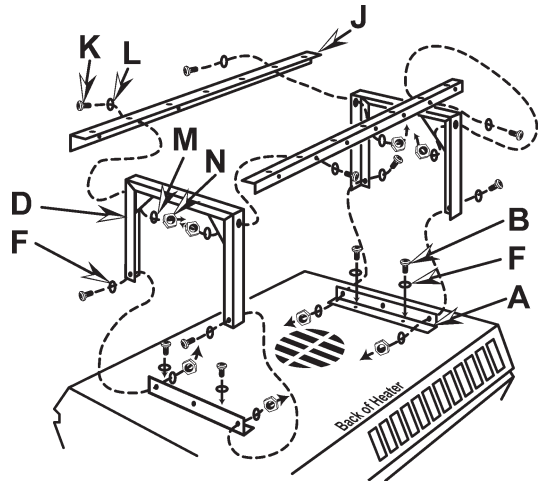

FIGURE 7
CEILING MOUNT VERTICAL DISCHARGE
V5150 SHOWN. SEE INSTALLATION INSTRUCTIONS
PROVIDED FOR V51100.



NOTE: When mounting heater using 5/16" all thread rod (by others) do not screw the rod more than 1/2" beyond the inside of the case.

5100 SERIES UNIT HEATER ELECTRICAL DATA (Table 2)

CATALOG NUMBER	KW RATING	BTU/HR (000)	HEATER / MOTOR VOLTAGE	HEATER PHASE	CONTROL VOLTAGE	AMPS PER PHASE	BRANCH CIRCUIT PROTECTION SIZE-(A)	SUPPLY WIRE SIZE 75° C AWG **
F3F5155CA1	55.0	187.7	208	3	24	152.8	200	2/0
HF3B5155CA1	55.0/41.25	187.7/140.8	240/208	3	24	132.5/114.6	175/150	1/0,1
P3P5155CA1	55.0	187.7	480	3	24	66.2	90	4
F3F5160CA1	60.0	204.7	208	3	24	166.7	225	2/0
HF3B5160CA1	60.0/45.0	204.7/153.6	240/208	3	24	144.6/125	200/175	1/0,1
P3P5160CA1	60.0	204.7	480	3	24	72.3	100	4
F3F5165CA1	65.0	221.8	208	3	24	180.6	250	3/0
HF3B5165CA1	65.0/48.75	221.8/166.4	240/208	3	24	156.6/135.4	200/175	2/0,2/0
P3P5165CA1	65.0	221.8	480	3	24	78.3	100	4
F3F5170CA1	70.0	238.9	208	3	24	194.4	250	3/0
HF3B5170CA1	70.0/52.5	238.9/179.2	240/208	3	24	168.7/145.8	225/200	2/0,1/0
P3P5170CA1	70.0	238.9	480	3	24	84.3	110	3
F3F5175CA1	75.0	256.0	208	3	24	208.3	300	4/0
HF3B5175CA1	75.0/56.25	256.0/192.0	240/208	3	24	180.7/156.3	250/200	3/0,2/0
P3P5175CA1	75.0	256.0	480	3	24	90.3	125	3
HF3B5180CA1	80.0/60.0	273.0/204.7	240/208	3	24	192.8/166.7	250/225	3/0,2/0
P3P5180CA1	80.0	273.0	480	3	24	96.3	125	3
HF3B5185CA1	85.0/63.75	290.0/217.5	240/208	3	24	204.8/177.1	300/225	4/0,3/0
P3P5185CA1	85.0	273.0	480	3	24	102.4	150	2
HF3B5190CA1	90.0/67.5	307.1/230.4	240/208	3	24	216.9/187.5	300/250	4/0,3/0
P3P5190CA1	90.0	307.1	480	3	24	108.4	150	2
HF3B5195CA1	95.0/71.25	324.2/243.1	240/208	3	24	229/198	300/250	250 MCM,3/0
P3P5195CA1	95.0	324.2	480	3	24	114.4	150	1
HF3B51100CA1	100.00/75.0	341.3/256.0	240/208	3	24	241/208.3	350/300	250MCM,4/0
P3P51100CA1	100.00	341.3	480	3	24	120.4	175	1

* Use 75 degree C Wire

**Use Copper Conductors on all heaters

5100 SERIES UNIT HEATER

AIR DELIVERY DATA

FAN MOTOR DATA

CFM at OUTLET	FPM at OUTLET	TEMPETURE RISE °F	HP	Motor RPM	MAX. MTG		AIR THROW	WEIGHT LBS.
					Horizontal	Vertical		
3400	1485	55	1/3	1100				
3400	1485	55/41	1/3	1100				
3400	1485	55	1/3	1100				
3400	1485	60	1/3	1100				
3400	1485	60/45	1/3	1100				
3400	1485	60	1/3	1100				
3400	1485	65	1/3	1100				
3400	1485	65/49	1/3	1100				
3400	1485	65	1/3	1100				
3400	1485	70	1/3	1100				
3400	1485	70/53	1/3	1100				
3400	1485	70	1/3	1100				
3400	1485	75	1/3	1100				
3400	1485	75/56	1/3	1100				
3400	1485	75	1/3	1100				
5000	1529	55/41	3/4	1100				
5000	1529	55	3/4	1100				
5000	1529	58/44	3/4	1100				
5000	1529	58	3/4	1100				
5000	1529	61/46	3/4	1100				
5000	1529	61	3/4	1100				
5000	1529	65/48	3/4	1100				
5000	1529	65	3/4	1100				
5000	1529	68/51	3/4	1100				
5000	1529	68	3/4	1100				

5100 SERIES UNIT HEATER TROUBLE SHOOTING GUIDE

SYMPTOM	POSSIBLE CAUSE(S)	CORRECTIVE ACTION
Thermostat calls for heat, but heater does not function.	<ol style="list-style-type: none"> 1. Open (blown) fuse 2. INCORRECT WIRING 3. Thermal cut-out open, deenergizing heater element and control circuit. Push reset button. 	<ol style="list-style-type: none"> 1. Replace fuses, check for cause. (see Replacement Parts List for fuse size) 2. CHECK WIRING CONNECTIONS 3. Check for the following: <ul style="list-style-type: none"> --- Correct supply volts and phase --- Correct control wiring (heater control must be thru thermostat control wiring section only). --- Power interruption to heater during heater operation. --- Restriction of air around heater 1-5 minute fan purge after thermostat off.
Fan motor runs "HOT"	<ol style="list-style-type: none"> 1. Dust accumulation or excessive dirt on motor 2. Dirt accumulation 3. Motor needs lubrication. 	<ol style="list-style-type: none"> 1. Clean fan motor and casing of grease and oil accumulation. 2. Clean louvers and between heating elements. 3. See Maintenance.
Fan motor runs, but no heat.	<ol style="list-style-type: none"> 1. Element contactor not operating correctly. 2. Element fuse blown. 	<ol style="list-style-type: none"> 1. Check wiring for open circuit. Replace contactor if defective 2. Replace fuses, check for cause. (see Replacement Parts List for fuse size)

MAINTENANCE

CAUTION: Make certain that the power source is disconnected before attempting to service or disassemble any component. If the power disconnect is out of the line of sight, lock it in the OPEN position and tag to prevent the application of power.

ELECTRICAL

Once a year inspect the control panel wiring to make certain insulation is intact and all connections are tight. Inspect all heater and relay contacts. If the contacts appear badly pitted or burned, replace the contactor / relay.

CLEANING

Clean the unit casing, fan and motor once a year. A dirty motor will tend to run hot and eventually will be damaged internally. Any rust spots on the casing should be cleaned and repainted.

LUBRICATION

All units have fan motors that are permanently lubricated so that only occasional cleaning is required.

5100 SERIES UNIT HEATER WIRING DIAGRAM SCHEDULE

DIAGRAM NO.	MODELS
WD5160	F3F5155CA1,F3F5160CA1,F3F5165CA1,F3F5170CA1,F3F5175CA1
WD5161	HF3B5155CA1,HF3B5160CA1,HF3B5165CA1,HF3B5170CA1,HF3B5175CA1
WD5162	P3P5155CA1,P3P5160CA1,P3P5165CA1,P3P5170CA1,P3P5175CA1
WD5163	HF3B5180CA1,HF3B5185CA1,HF3B5190CA1,HF3B5195CA1,HF3B51100CA1
WD5164	P3P5180CA1,P3P5185CA1,P3P5190CA1,P3P5195CA1,P3P51100CA1

SERIES 5100
TASKMASTER
SC5100

Installation Instructions
FOR MODELS 5155 THRU 51100

READ THESE INSTRUCTIONS CAREFULLY BEFORE INSTALLING CONTROL. BE SURE TO DE-ENERGIZE POWER SOURCE TO UNIT BEFORE INSTALLING CONTROL.

- 1.) Disconnect heater from power supply.
- 2.) Mount the controller in the control compartment as shown.
- 3.) Refer to page 2 for wiring.

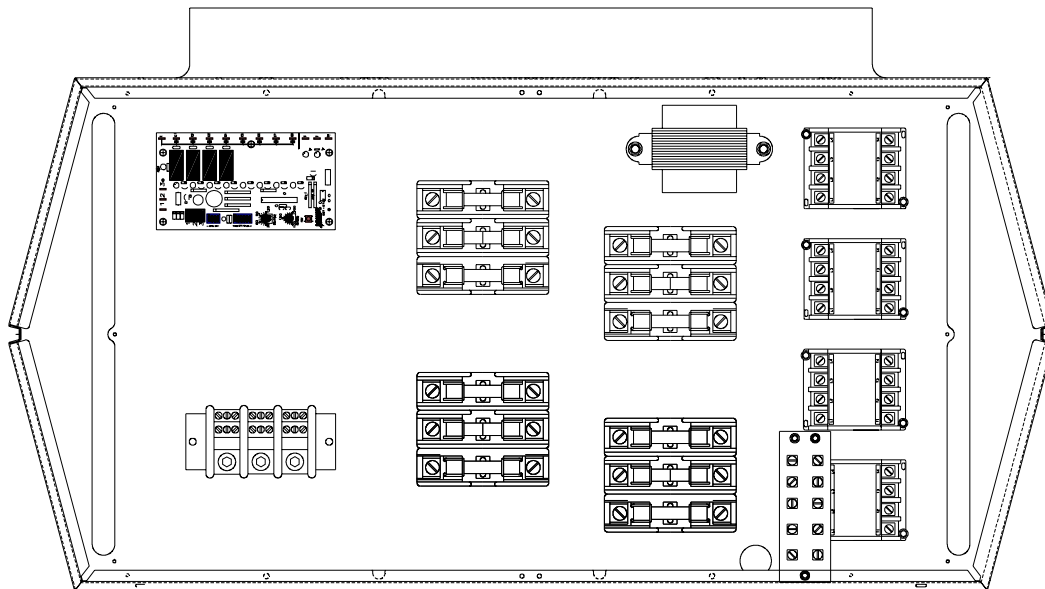

- 1) AFTER MOUNTING BOARD IN HEATER, PROCEED WITH WIRING AS SHOWN.
- 2) TERMINAL ARE IN REFERENCE TO THE TERMINAL BOARD LOCATED IN THE CONTROL COMPARTMENT.
- 3) REFER TO MANUFACTURERS MANUAL FOR THERMOSTAT, 0-10VDC OR 4-20mA SIGNAL CONNECTIONS AND SETTINGS. "DIP" SWITCHES MUST BE SET FOR INPUT AND STAGING. SEQUENCING OPERATION MUST ALWAYS BE LAST IN FIRST OUT(LIFO) WHICH IS THE FACTORY DEFAULT SETTING.
- 4) THE 5100 SERIES 55-75kW UNITS ARE CAPABLE OF 3 STAGES, THE 80-100kW ARE CAPABLE OF 4 STAGES.

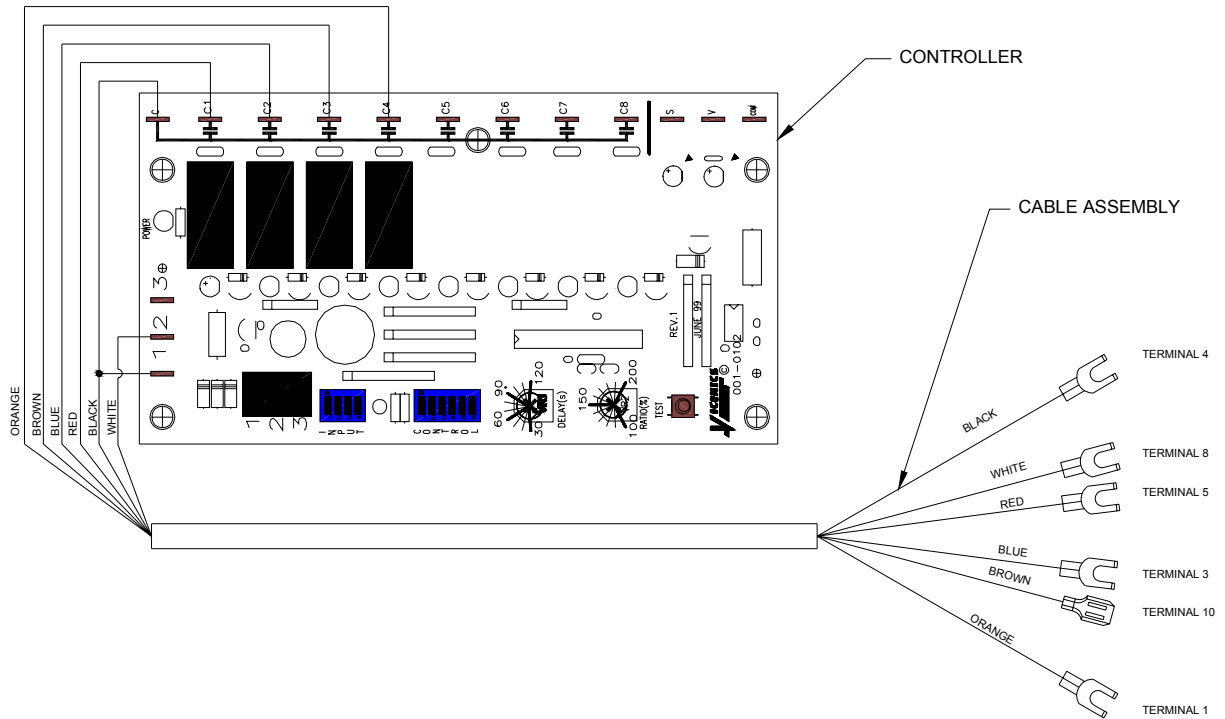

SERIES 5100 TASKMASTER

INSTALLATION INSTRUCTIONS

DCS202 POWER DISCONNECT SWITCH TASKMASTER SERIES
RATING - 2 POLE ● 20 AMP 277 VAC RESISTIVE

READ THESE INSTRUCTIONS THOROUGHLY BEFORE INSTALLING SWITCH. BE SURE TO DE-ENERGIZE POWER SOURCE TO UNIT BEFORE INSTALLING SWITCH. CHECK HEATER DATA LABEL TO INSURE THAT HEATER ELECTRICAL RATING DOES NOT EXCEED THE POWER DISCONNECT ELECTRICAL RATING.

SUPPLY WIRES MUST BE COPPER CONDUCTORS ONLY.

ALL WIRING TO BE IN ACCORDANCE WITH CSA, NEC AND LOCAL CODES. DO NOT REMOVE FISHPAPER BARRIER FROM SWITCH ASSEMBLY. DO NOT INTERRUPT POWER TO HEATER WHILE THE UNIT IS OPERATING IN ORDER TO PERFORM NORMAL MAINTENANCE SERVICE. ANY POWER INTERRUPTION DURING NORMAL OPERATION WILL PREVENT THE FAN FROM PURGING THE UNIT OF RESIDUAL HEAT.

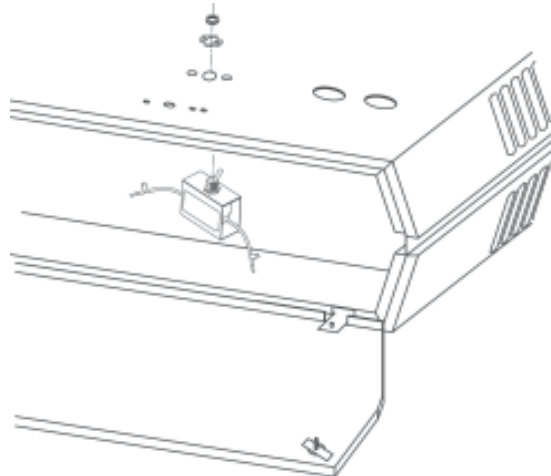

- 1.) Remove 1/2" (13mm) diameter knockout from heater back.
NOTE: 1/2" (13mm) diameter knockout is located on the heater back center approximately 3 1/2" (89mm) from the bottom of heater. NOTE: DO NOT remove fishpaper barrier from switch assembly.
- 2.) Remove knurled nut and "ON-OFF" indicator ring from switch assembly.
- 3.) Position switch assembly inside heater control compartment so the data label on switch assembly can be visible from open side of compartment. Align flats on switch assembly with flats in heater back. Install "ON-OFF" indicator ring. Secure switch assembly to heater back with knurled nut.
- 4.) Wire switch according to wiring diagram located on inside of bottom panel. Attach switch leads T1 and T2 to L1 and L2 of heater terminal block. Attach switch leads L1 and L2 to incoming supply conductors L1 and L2 by suitable means.
- 5.) Restore power to unit and check for proper operation.

SERIES 5100

TASKMASTER

INSTALLATION INSTRUCTIONS

DCS403, DCS603, DCS1003 POWER DISCONNECT SWITCH • TASK MASTER SERIES

RATING	DCS403	3 POLE	40 AMPS	600 VAC RESISTIVE
	DCS603	3 POLE	60 AMPS	600 VAC RESISTIVE
	DCS1003	3 POLE	100 AMPS	600 VAC RESISTIVE

January 1990

WARNING: Open supply circuit disconnect switch before servicing unit. Failure to do so may result in personal injury or death from electrical shock.

NOTE: Before installing disconnect switch, check heater data label to ensure that heater electrical rating does not exceed the switch electrical rating.

NOTE: All wiring must be done in accordance with National and Local Electrical Codes. Supply conductors to unit must be copper.

- 1.) Disconnect heater from power supply.
- 2.) Locate and remove large knockout and two adjacent small knockouts from heater where switch is to be mounted.
 - A.) 3-5KW - 1/2" diameter knockout is located centered on heater back approximately 3 1/2" from bottom of the unit, with the two slotted knockouts on each side.
 - B.) 7-50KW - 1/2" diameter knockout is located on left hand side of heater front approximately 2 1/2" from bottom of unit, with the two 3/16" slotted knockouts on each side.
- 3.) Remove the knob and mounting plate from switch assembly. Remove terminal shield.
(NOTE: Terminal shield must be installed on disconnect switch after incoming supply wiring has been connected).

- 4.) Connect the incoming power supply leads to terminals L1-L2-L3 of the disconnect switch. Connect the incoming ground lead to the grounding screw (or lug). On some models with adequate access the switch may be mounted (Step 5) prior to connecting the supply wiring.
- 5.) Place the switch inside the heater control compartment with the shaft extending through the 1/2" diameter knockout. The switch must be oriented so the terminal shield is positioned toward the left side of the heater. Data and caution labels must be plainly visible from open end of compartment. Align switch assembly and mounting plate with the 3/16" slotted knockouts in unit and secure with the #6 or #8 screws provided.
- 6.) Connect the leadwires on the switch, marked T1-T2-T3 to the heater power terminal block marked L1-L2-L3 (Note: For single phase units remove center leadwire marked T2).
- 7.) Attach the "On-Off" cover to the mounting plate. Install knob and tighten screw.
- 8.) Check all connectors for tightness and electrical clearances. Close cover and latch, then restore electrical power and check heater in each mode of operation.

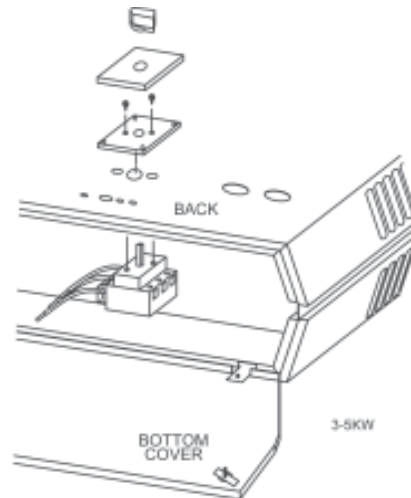
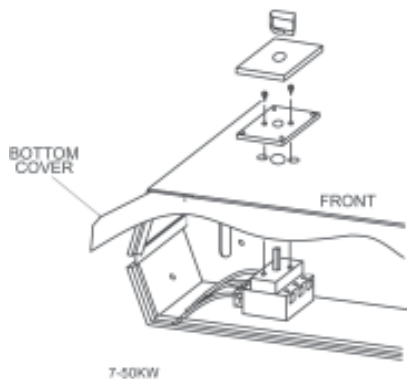

SERIES 5100

TASKMASTER

Installation Instructions

FS5101 • TASKMASTER SERIES
UNIT MOUNTED LINE VOLTAGE SUMMER FAN SWITCH
FOR USE ON UNITS WITH 208, 240, 277 VOLT SUPPLY ONLY

READ THESE INSTRUCTIONS CAREFULLY BEFORE INSTALLING SWITCH. BE SURE TO DE-ENERGIZE POWER SOURCE TO UNIT BEFORE INSTALLING SWITCH. BE SURE TO INSTALL THE APPROPRIATE MODEL SWITCH ON THE CORRECT UNIT.

- 1.) Disconnect heater from power supply.
- 2.) Remove appropriate knockout for switch being used. Refer to Fig. 1.



Fig. 1

Models 5102 thru 5105 - Fig. 2

Knockout is located on heater back center approximately 1 1/8" (29mm) from bottom of heater.

Models 5107 thru 5120 - Fig. 3

Knockout is located on heater back approximately 3 1/4" (83mm) from bottom of heater with the 1/2" (13mm) diameter knockout located approximately 3 3/4" (95mm) to the right of the back of center.

Models 5125 thru 51100 - Fig. 4

Knockout is located on heater back approximately 1 3/4" (44mm) from bottom of heater with the 1/2" (13mm) diameter knockout located approximately 5" (127mm) to the left of the back center.

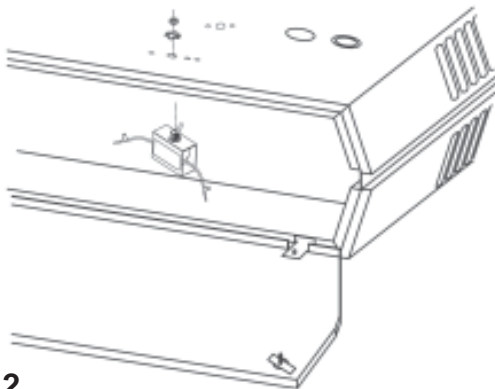

Fig. 2

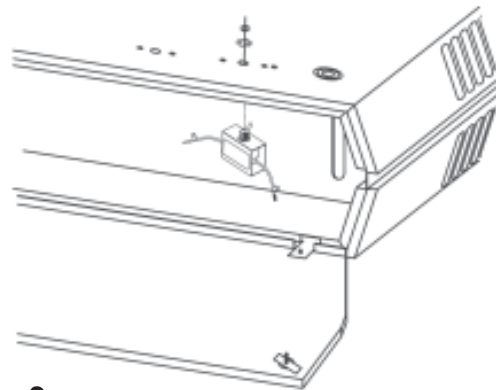

Fig. 3

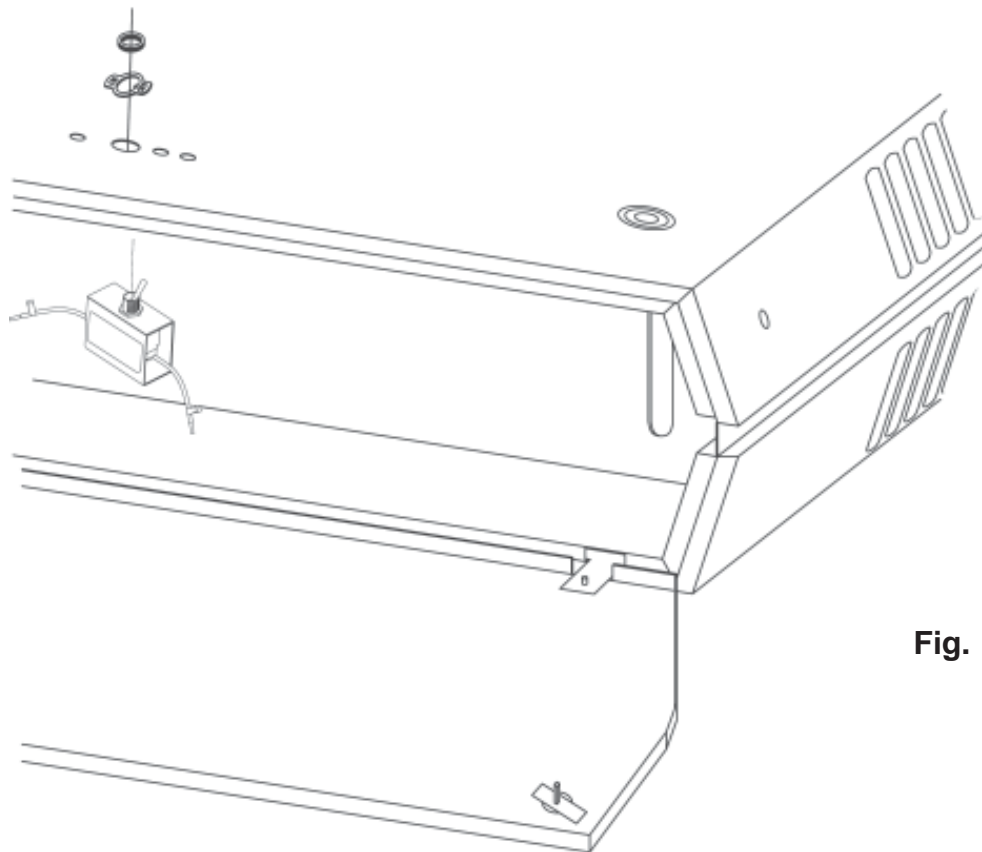

Fig. 4

- 3.) Remove knurled nut and "On-Off" indicator ring from switch assembly.
- 4.) Align flats on switch with flats in knockout (Note position switch so data label will be visible from open end of control compartment.
- 5.) Install "On-Off" indicator ring and secure switch assembly to heater with knurled nut.
- 6.) Wire switch according to wiring diagram located on inside of heater bottom panel. Attach switch leads 7 & 9 to terminals 7 & 9 on terminal board.
- 7.) Remove paper backing from "Fan-Heat" decal and affix to unit with fan toward on and heat toward off.
- 8.) After power is available to unit, check for proper operation.

NOTE: For summer fan operation only, thermostat must be in OFF position.

TPI CORPORATION
P.O. BOX 4973
JOHNSON CITY, TN 37602
(423) 477-4131
(423) 477-0064

FORM: 8948
ECO 1-5719

SERIES 5100

TASKMASTER

FSW5111 •TASKMASTER SERIES
REMOTE (WALL MOUNT) SUMMER FAN SWITCH

LINE VOLTAGE SWITCH FOR USE ONLY ON TASKMASTER HEATERS WITH A POWER SUPPLY OF 208, 240 OR 277 VOLT SERVICE.

READ THESE INSTRUCTIONS CAREFULLY BEFORE INSTALLING SWITCH. DO NOT USE THIS SWITCH ON UNITS WITH 480 OR 600 VOLT MOTOR CIRCUIT. BE SURE TO DE-ENERGIZE POWER SOURCE TO UNIT BEFORE INSTALLING SWITCH. ALL CONDUCTORS FROM SWITCH TO UNIT MUST BE COPPER (NEC) AND EXISTING LOCAL CODE REQUIREMENTS.

- 1.) Disconnect heater from power supply.
- 2.) Remove 7/8" diameter knockout from heater back for control wiring from switch.
Models 5102 thru 5105
7/8" diameter knockouts located 2 1/2" to right of heater back center and 3 5/16" from bottom of heater.
Models 5107 thru 5120
7/8" diameter knockouts located 5 1/2" to left of heater back center and 1 1/2" from bottom of heater.
Models 5125 thru 5150
7/8" diameter knockouts located 5 1/16" to left of heater back center and 3 5/8" from bottom of heater.
Models 5155 thru 5175
7/8" diameter knockouts located 5 1/16" to right of heater back center and 3 7/16" from bottom of heater.
Models 5180 thru 51100
7/8" diameter knockouts located 5 1/16" to right of heater back center and 5" from bottom of heater.
- 3.) Mount switch assembly in remotely located utility box.
- 4.) Wire switch according to wiring diagram located on inside of heater bottom panel. Attach leads 7 & 9 from switch to heater terminals 7 & 9 on heater terminal board.
- 5.) Remove paper backing from "Fan-Heat" decal and affix to utility box cover with fan toward on and heat toward off.
- 6.) After installation is complete, restore power to heater and check for proper operation.

NOTE: For summer fan-operation only thermostat must be in OFF position.

FORM: 8949
ECO 1-5719

SERIES 5100 TASKMASTER

INSTALLATION INSTRUCTIONS

FSW5112 • TASKMASTER SERIES
REMOTE (WALL MOUNT) LOW VOLTAGE SUMMER FAN SWITCH

LOW VOLTAGE SWITCH FOR USE ON TASKMASTER HEATERS WITH SUFFIX CODE "CA1" ONLY.

THIS ACCESSORY PACKAGE CONTAINS A REMOTE FAN SWITCH AND A LOW VOLTAGE RELAY FOR UNIT MOUNTING.

READ THESE INSTRUCTIONS CAREFULLY BEFORE INSTALLING SWITCH. USE THIS SWITCH ONLY ON UNITS WITH 24 VOLT CONTROL CIRCUITS. BE SURE TO DE-ENERGIZE POWER SOURCE TO UNIT BEFORE INSTALLING SWITCH. ALL CONDUCTORS FROM SWITCH TO UNIT MUST BE COPPER. ALL WIRING TO BE IN ACCORDANCE WITH THE NATIONAL ELECTRIC CODE (NEC) AND EXISTING LOCAL CODE REQUIREMENTS.

- 1.) Disconnect heater from power supply.
- 2.) Remove 7/8" diameter knockout from heater back for control wiring switch:
Models 5102 thru 5105
7/8" diameter knockout is located 2 1/2" to right of heater back center and 3 5/16" from bottom of heater.
Models 5107 thru 5120
7/8" diameter knockout is located 5 1/2" to left of heater back center and 1 1/2" from bottom of heater.
Models 5125 thru 51100
7/8" diameter knockout is located 5 1/16" to left of heater back center and 3 5/8" from bottom of heater.
- 3.) Mount switch assembly to remotely located utility box.
- 4.) Wire switch according to wiring diagram located on inside of heater bottom panel. Attach leads 2 and 4 from switch to heater terminals 2 and 4 on heater terminal board.
- 5.) Fig. 1 Mount low voltage relay in wiring compartment- Slip long leg of relay base under raised section of control mounting plate and attach diagonally opposite corner of relay base to control mounting plate with the No. 8 sheet metal screw supplied.
NOTE: Models 5102 thru 5105
Relay is mounted next to heater power terminal block.
Models 5107 thru 51100
Relay is mounted next to heater control terminal board.
- 6.) Wire relay according to wiring diagram located on inside of heater bottom panel. Attach relay leads 6, 8, 7 & 9 to terminals 6, 8, 7 & 9 on terminal board.
- 7.) Remove paper backing from "Fan-Heat" decal and affix to utility box cover with fan toward on and heat toward off.
- 8.) After installation is complete, restore power to heater and check for proper operation.
NOTE: For summer fan operation only thermostat must be in OFF position.

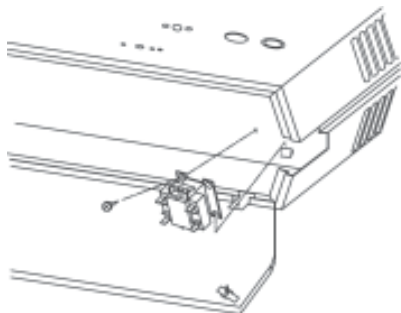

2-5 kw

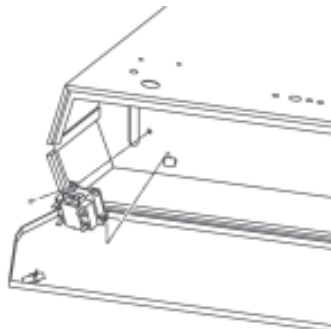

7-20 kw

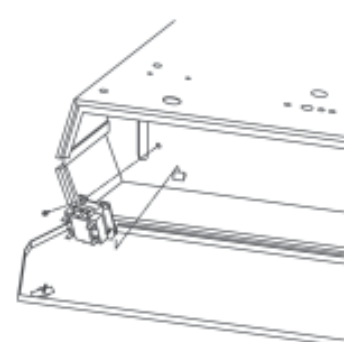

25-50kw

SERIES 5100
TASKMASTER
INSTALLATION INSTRUCTIONS

TW1510, TW1512
REMOTE MOUNTING
LINE VOLTAGE THERMOSTAT
SINGLE STAGE
TW1510 (SPST)
TW1512 (DPST)

- 1) Disconnect heater from power supply.
 - 2) Mount wall thermostat in desired location.
 - 3) Wire the thermostat to the heater following the wiring diagram located on the heater. All wiring to be in accordance with local and/or national codes.
 - 4) Restore power to the heater.
 - 5) Check for proper thermostat operation
-
-

INSTRUCTIONS D'INSTALLATION

THERMOSTAT À TENSION COMPOSÉE
TW1510, TW1512
INSTALLATION À DISTANCE
À UN ÉTAGE
TW1510 (SPST)
TW1512 (DPST)

- 1) Débranchez le radiateur de l'alimentation de courant.
- 2) Installez le thermostat mural à l'endroit désiré.
- 3) Connectez le thermostat au radiateur en suivant le schéma de filerie situé sur le radiateur. Toute la filerie doit être en conformité avec les codes national et local.
- 4) Remettez le radiateur sous tension.
- 5) Vérifier au bon fonctionnement.

SERIES 5100
TASKMASTER
INSTALLATION INSTRUCTIONS

CEILING HANGER BRACKET ● TASKMASTER SERIES
VERTICAL DISCHARGE AIR DELIVERY

MODEL V5105 USE WITH 5102-5105 UNITS
MODEL V5120 USE WITH 5107-5120 UNITS
MODEL V5150 USE WITH 5125-5175 UNITS

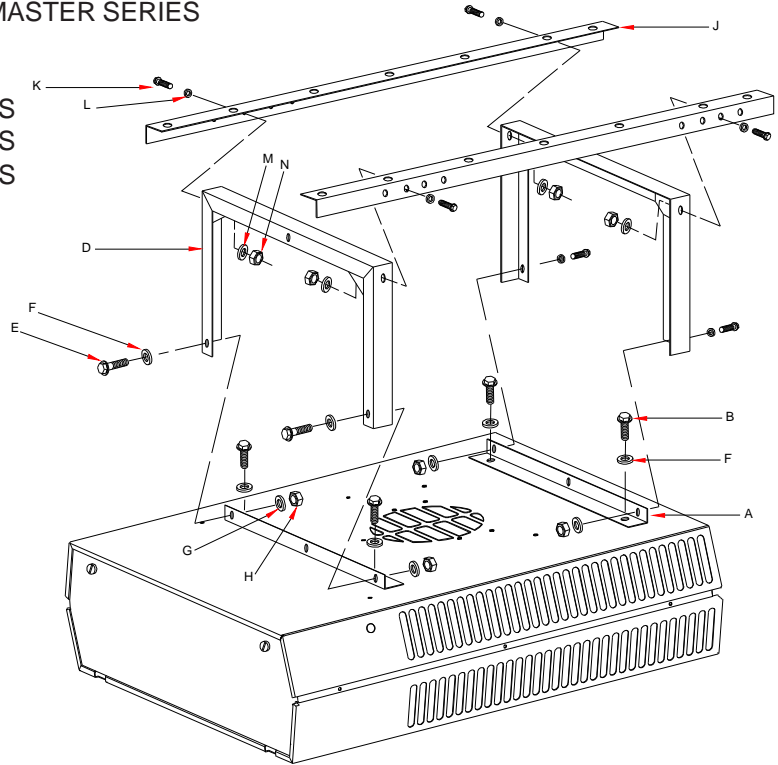

MODEL V5105 IS FOR USE WITH 5102 THRU 5105 HEATERS.
MINIMUM MOUNTING DISTANCES FOR 5102 THRU 5105 HEATERS:
12" FROM CEILING AND ADJACENT SURFACES
7' FROM FLOOR TO FRONT EDGE OF HEATER FRONT VENTURI

MODEL V5120 IS FOR USE WITH 5107 THRU 5120 HEATERS
MODEL V5150 IS FOR USE WITH 5125 THRU 5175 HEATERS
MINIMUM MOUNTING DISTANCES FOR 5107 THRU 5175 HEATERS:
18" FROM CEILING
24" FROM ADJACENT SURFACES
7' FROM FLOOR TO FRONT EDGE OF HEATER FRONT VENTURI

- 1) Attach short angle brackets "A" to back of heater with four 5/16-18 bolts "B", lockwashers "F". Be sure vertical leg of angle brackets face top and bottom of heater.
- 2) Attach inverted U frames "D" to short angle brackets with four 5/16-18 bolts "E", washers "F", lockwashers "G" and nuts "H", oriented as shown.
- 3) Attach long angle brackets "J" to inverted U frames "D" with four 5/16-18 bolts "K", washers "L", lockwashers "M" and nuts "N".
- 4) Attach heater and bracket assembly to ceiling in desired location using customer supplied hardware sufficient to support the assembly.

FORM: 56620-004
ECO 1-5719

SERIES 5100
TASKMASTER
INSTALLATION INSTRUCTIONS

TW1510, TW1512
REMOTE MOUNTING
LINE VOLTAGE THERMOSTAT
SINGLE STAGE
TW1510 (SPST)
TW1512 (DPST)

- 1) Disconnect heater from power supply.
 - 2) Mount wall thermostat in desired location.
 - 3) Wire the thermostat to the heater following the wiring diagram located on the heater. All wiring to be in accordance with local and/or national codes.
 - 4) Restore power to the heater.
 - 5) Check for proper thermostat operation
-
-

INSTRUCTIONS D'INSTALLATION

THERMOSTAT À TENSION COMPOSÉE
TW1510, TW1512
INSTALLATION À DISTANCE
À UN ÉTAGE
TW1510 (SPST)
TW1512 (DPST)

- 1) Débranchez le radiateur de l'alimentation de courant.
- 2) Installez le thermostat mural à l'endroit désiré.
- 3) Connectez le thermostat au radiateur en suivant le schéma de filerie situé sur le radiateur. Toute la filerie doit être en conformité avec les codes national et local.
- 4) Remettez le radiateur sous tension.
- 5) Vérifier au bon fonctionnement.

TASKMASTER

Installation Instructions

TFS5102 ● TASKMASTER SERIES
 REMOTE MOUNTING
 24 VOLT OPERATION
 TWO STAGE CONTROL & INTEGRAL FAN SWITCH

- 1.) Disconnect heater from power supply.
- 2.) At the desired location, run the thermostat cable through the hole in the center of the thermostat mounting sub-base. Leave about three inches of wire for connections. For the correct number of wires, see appropriate heater or control package wiring diagram and instructions.
- 3.) Attach the sub-base directly to the wall or on a HORIZONTAL outlet box. Level the sub-base with a spirit level.
- 4.) Connect the wires to the sub-base following the wiring diagram. complete installation of wiring on the heater and/or control package. Plug the cable entrance hole to prevent drafts from affecting thermostat operation.
- 5.) Remove the thermostat cover by pulling up the bottom edge until it snaps free of the locking springs. Set the heat anticipator to correspond with the primary system control (relay, etc.). The tabs along the top inside edge fit the sockets on the upper corners of the sub-base.
- 6.) Hang the thermostat on the sub-base and tighten the two captive screws on the thermostat base. Replace cover by hooking cover tabs into the thermostat base and pushing down until the cover snaps into the locking springs.
- 7.) Restore power to the heater and check for correct operation.

FAN SWITCH	SYSTEM SWITCH	FUNCTION
On	Off	Fan on - heat off
On	Auto	Fan on - stat cycles 2 stages heat
Auto	Off	Fan off - heat off
Auto	Auto	Fan cycles with first stage heat- stat cycles 2 stages heat

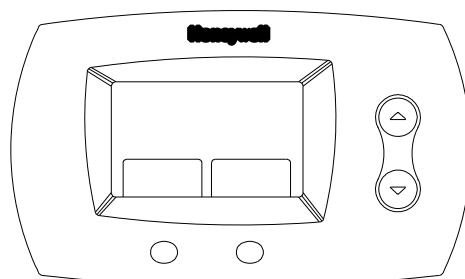

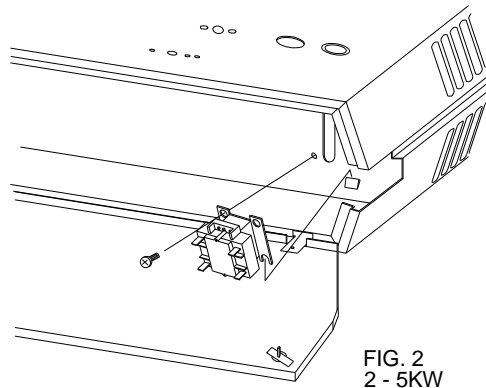

FIG. 2
2 - 5KW

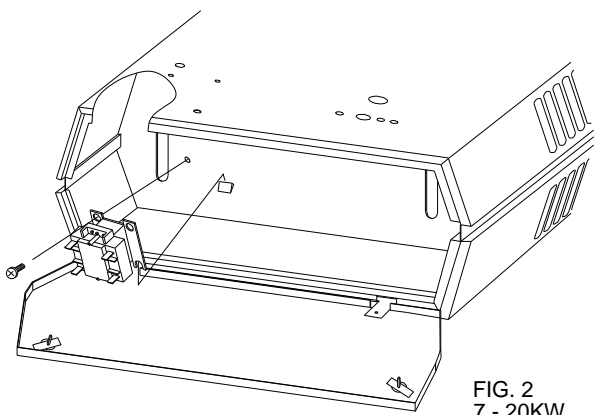

FIG. 2
7 - 20KW

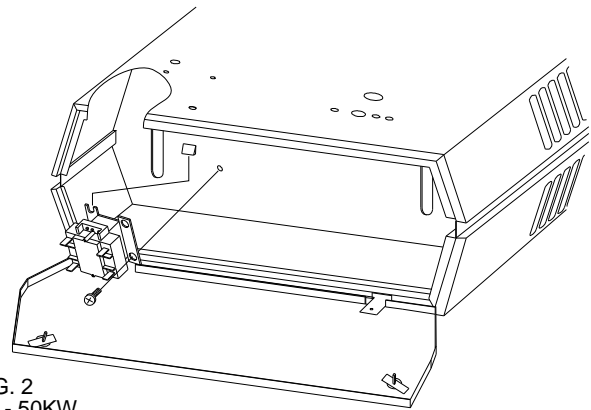

FIG. 2
25 - 50KW

- 8.) **Fig. 2** Mount low volt relay in wiring compartment. Slip long leg of relay base under raised section of control mounting plate and attach diagonally opposite corner of relay base to control mounting plate with the No. 8 sheet metal screw supplied.

NOTE: Models 5102 thru 5105

Relay is mounted next to heater terminal block

Models 5107 thru 5150

Relay is mounted next to heater terminal board

- 9.) Wire relay according to wiring diagram located on inside of heater bottom panel. Attach relay leads 6, 8, 7 & 9 to terminals 6, 8, 7 & 9 on terminal board.
- 10.) After installation is complete, depress the reset button to insure continuity before applying power. After power is available to unit, check for proper operation.

SERIES 5100
TASKMASTER
INSTALLATION INSTRUCTIONS

Dust Shield - Taskmaster Series
For Horizontal Air Delivery Units

Model DS5105 Use with 5102-5105 Units
Model DS5120 Use with 5107-5120 Units
Model DS5150 Use with 5125-5150 Units

- 1) Install the hanger base "A" on the heater following the instruction sheet packed with the combination wall/ceiling bracket or the hanger base.
- 2) Attach the hanger bracket to the wall or ceiling as desired following instructions packed with the bracket.
- 3) Following the correct illustration below:

- Fig. A Wall Mounted Bracket
- Fig. B Ceiling Mounted Bracket
- Fig. C Customer Supplied Bracket or Direct Connection to Building Structural Member.

Position the dust shield as shown and insert the bolt of the hanger base "A" through the hole in the dust shield, attach to the hanger bracket or structural member and attach the lock nut "E" and complete installation as per the bracket installation sheet.

NOTE: The dust shield is to be positioned on the same axis as the heater.

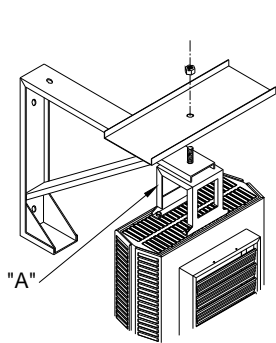

Fig. A

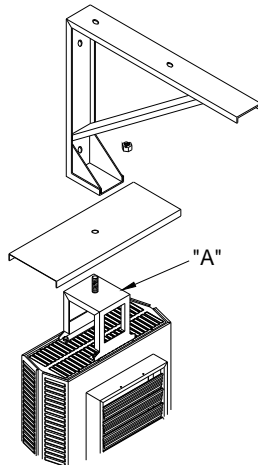

Fig. B

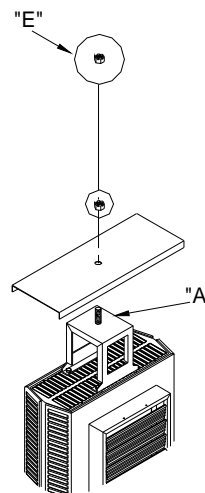

Fig. C

FORM: 56621-101
ECO 1-5719

SERIES 5100
TASKMASTER
INSTALLATION INSTRUCTIONS

CAUTION: Models 5155 thru 5175 require that two circuits be wired to stage one and one circuit be wired to stage two.

TW123 - TASKMASTER SERIES
REMOTE MOUNTING
24 VOLT OPERATION
TWO STAGE CONTROL

1. Disconnect heater from power supply.
2. At the desired location, run the thermostat cable through the hole in the center of the thermostat mounting sub-base. Leave about three inches of wire for connections. For the correct number of wires, see appropriate heater or control package wiring diagram and instructions.
3. Attach the sub-base directly to the wall or on a HORIZONTAL outlet box. Level the sub-base with a spirit level.
4. Connect the wires to the sub-base following the wiring diagram. Complete installation of wiring on the heater and/or control package. Plug the cable entrance hole to prevent drafts from affecting thermostat operation.
5. Remove the thermostat cover by pulling up the bottom edge until it snaps free of the locking springs. Set the heat anticipators to .25 amp. After usage, readjust as needed. The tabs along the top inside edge fit the sockets on the upper corners of the sub-base.
6. Hang the thermostat on the sub-base and tighten the two captive screws on the thermostat base. Replace cover by hooking cover tabs into the thermostat base and pushing down until the cover snaps into the locking springs.
7. Restore power to heater and check for correct operation. The thermostat will, on a fall in space temperature below its setting, energize the 2 stages of heating in sequence. On a rise in space temperature towards the stat setting, the sequence is reversed.

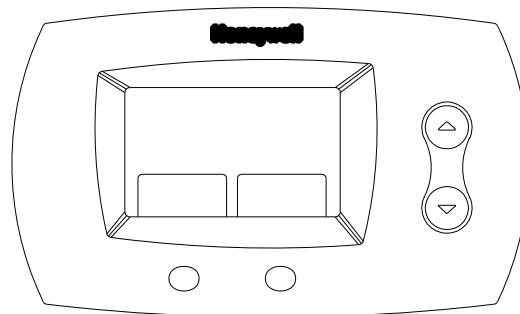

FORM: 56621-104
ECO 1-5719

SERIES 5100

TASKMASTER

Installation Instructions

DCS252 POWER DISCONNECT SWITCH • TASKMASTER SERIES
RATING - 2 POLE 25 AMP 277 VAC RESISTIVE

READ THESE INSTRUCTIONS THOROUGHLY BEFORE INSTALLING SWITCH. BE SURE TO DEENERGIZE POWER SOURCE TO UNIT BEFORE INSTALLING SWITCH. CHECK HEATER DATA TAPE TO INSURE THAT HEATER ELECTRICAL RATING DOES NOT EXCEED THE POWER DISCONNECT ELECTRICAL RATING.

SUPPLY WIRES MUST BE COPPER CONDUCTORS ONLY.

ALL WIRING TO BE IN ACCORDANCE WITH CSA, NEC AND LOCAL CODES. DO NOT REMOVE SWITCH OR FISHPAPER BARRIER FROM SWITCH MOUNTING BRACKET. DO NOT INTERRUPT POWER TO HEATER WHILE THE UNIT IS OPERATING IN ORDER TO PERFORM NORMAL MAINTENANCE SERVICE. ANY POWER INTERRUPTION DURING NORMAL OPERATION WILL PREVENT THE FAN FROM PURGING THE UNIT OF RESIDUAL HEAT.

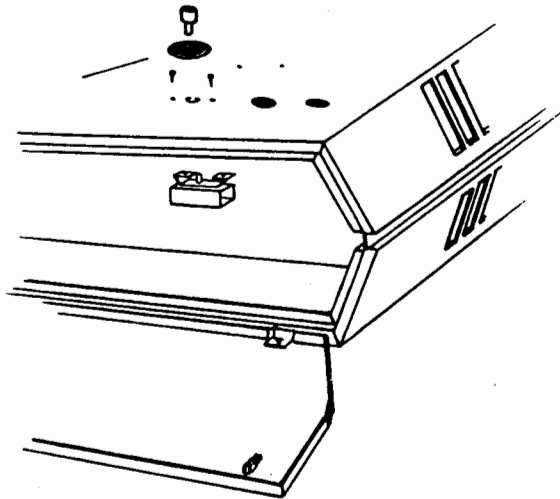

- 1) Remove ½" (13mm) dia. knockout and two adjacent small knockouts from heater back.

NOTE: ½" (13mm) dia. knockout is located on the heater back center approximately 3½" (89mm) from the bottom of heater with the two small knockouts on either side.

- 2) Remove paper backing from "ON-OFF" decal, align with the ½" (13mm) dia. knockout hole and affix to heater back with "ON" toward top of heater.
- 3) Rotate switch shaft clockwise to the ON position.
- 4) With flat portion of switch shaft toward top of heater, attach switch bracket to heater back by means of the two No. 8 sheet metal screws supplied.
- 5) Push knob on switch shaft and check alignment of knob pointer with "ON-OFF" decal.
- 6) Wire switch according to wiring diagram located on inside of bottom panel. Attach switch leads T1 and T2 to L1 and L2 of heater terminal block.
Attach switch leads L1 and L2 to incoming supply conductors L1 and L2 by suitable means.
- 7) Restore power to unit and check for proper operation.

SERIES 5100
TASKMASTER

Installation Instructions

**DCS253 POWER DISCONNECT SWITCH • TASKMASTER SERIES
RATING – 3 POLE 40 AMP 600 VAC RESISTIVE**

READ THESE INSTRUCTIONS THOROUGHLY BEFORE INSTALLING SWITCH. BE SURE TO DEENERGIZE POWER SOURCE TO UNIT BEFORE INSTALLING SWITCH. CHECK HEATER DATA TAPE TO INSURE THAT HEATER ELECTRICAL RATING DOES NOT EXCEED THE POWER DISCONNECT SWITCH'S ELECTRICAL RATING.

SUPPLY WIRES MUST BE COPPER CONDUCTORS ONLY.

ALL WIRING MUST BE IN ACCORDANCE WITH NEC AND LOCAL CODES. KIT CONSISTS OF: THE DISCONNECT SWITCH ASSEMBLY WITH KNOB AND LEADWIRES, TWO #8 MOUNTING SCREWS, "ON-OFF" DECAL, INSTALLATION INSTRUCTIONS.

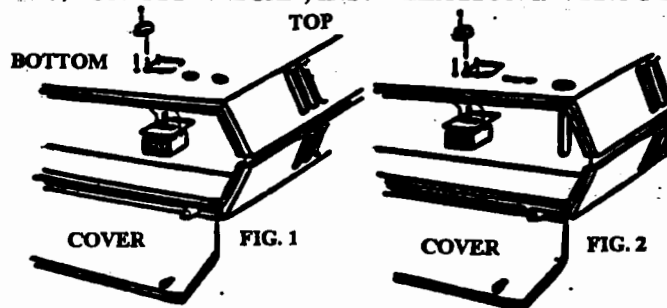

- 1) **Locate and remove knockouts where switch is to be mounted.**
 - a. **For heater Model No's 5103 thru 5105 (Fig. 1)**
Remove 1/2" dia. knockout and two adjacent small knockouts from heater back.
NOTE: 1/2" dia. knockout is located on the back center approximately 3 1/2" from the bottom of heater with a small knockout on either side.
 - b. **For heater Model No's 5107 thru 5115 (Fig. 2)**
Remove 5/8" wide knockout slot and two adjacent small knockout slots from heater back.
NOTE: 5/8" wide knockout slot is located on the heater back approximately 3 1/2" from the bottom of heater with a small knockout on either side.
- 2) **Remove the knob from the switch by loosening the screw in the center of the knob and pulling it off.**
- 3) **Connect the incoming power supply leads to terminals L1-L2-L3 of the disconnect switch. Connect the incoming ground lead to the grounding screw (or lug).**
- 4) **Mount the switch inside the heater control compartment, with the shaft extending through the knockout, using the two #8 x 5/16 phillips head screws provided. The switch should be oriented so the side with the data label is facing the open side of the compartment (visible when installed).**
- 5) **Connect the lead wires on the switch, marked T1-T2-T3 to the heater power terminal block marked L1-L2-L3.**
- 6) **Install the knob and tighten the screw.**
- 7) **Attach the "ON-OFF" decal located per Fig.1. Peel off the backing paper, position carefully then press firmly onto the heater cabinet. Note that knob rotation clockwise is "ON" and counterclockwise is "OFF".**
- 8) **Check all connections for tightness and electrical clearances. Close cover and latch, then restore electrical power and check heater in each mode of operation.**

SERIES 5100
TASKMASTER
INSTALLATION INSTRUCTIONS

TASKMASTER SERIES

T5100, T5102, T5122, TC5102 AND TC5103 Built-in Thermostat Kits for Field installation in the 5100 Series Unit Heaters.

T5100 provides SPST line voltage control for single phase heaters up to 277V, 25a.
or
Pilot duty control (24-277 volt) for contactor equipped heaters.

T5102 provides double pole line voltage control breaking all ungrounded conductors for single phase heaters up to 277V, 25 amperes.
or
Two pole line cycling control for 3 phase heaters up to 240 volts, 25 amps but does not break all ungrounded conductors on 3 phase applications.

T5122 provides two stage low voltage (24V) control for two stage heaters. Two separate circuits are controlled by the same sensing element. Switches controlling these circuits are calibrated to make or break in sequence.

TC5102 is a thermostat and relay for use with 480 & 600 volt heaters to control the fan motor. It provides for sensing of heat accumulation (strat-stat) near the ceiling and switches the fan motor on to recirculate and recover this heat.

TC5103 provides control of the fan motor on 208, 240 & 277 volt heaters to recover and recirculate the stratified heat accumulated near the ceiling.

Please read each installation instruction carefully before beginning installation.

INSTALLATION INSTRUCTIONS T5100, T5102, T5122

- 1.) CAUTION:
To avoid possible electric shock, turn heater OFF at distribution panel. On heaters equipped with a disconnect switch, rotate switch to the OFF position.
- 2.) Unlock the 2 screws on the control panel door and let door swing down. Some models have an additional center door catch. Squeeze catch to open.
- 3.) Remove 1/2 (13mm) diameter thermostat bulb exit knockout from back of heater, Fig. 1. Feed thermostat bulb and capillary tube thru knockout.
CAUTION: Keep capillary tubing away from internal electrical components.
- 4.) Remove 2 small thermostat bulb clip knockouts on the rear of the heater, see Fig. 1. Insert 2 bulb clips (supplied). Snap thermostat bulb into clips.
- 5.) Remove the three stat mounting knockouts from side of control compartment: (1) 9/16 & (2) 3/16. Remove backing from label (supplied). Align label with thermostat shaft hole and position as in Fig. 1. Press label on heater side as shown.
- 6.) Note orientation of leg on thermostat bracket (see Fig. 1). Position *only* as shown. Install thermostat with the (2) number 8 mounting screws provided.

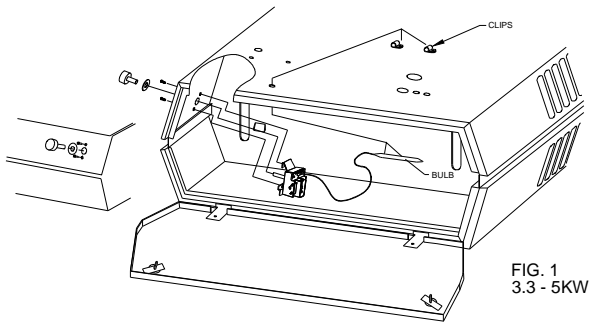

FIG. 1
3.3 - 5KW

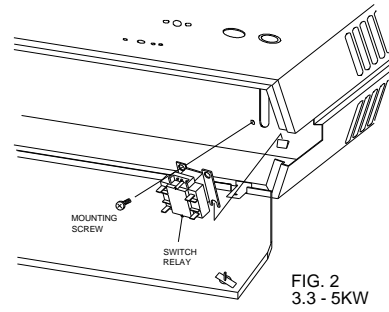

FIG. 2
3.3 - 5KW

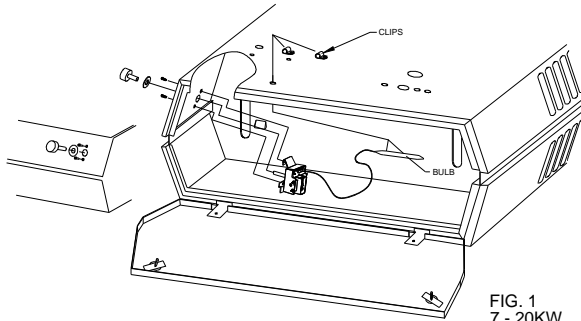

FIG. 1
7 - 20KW

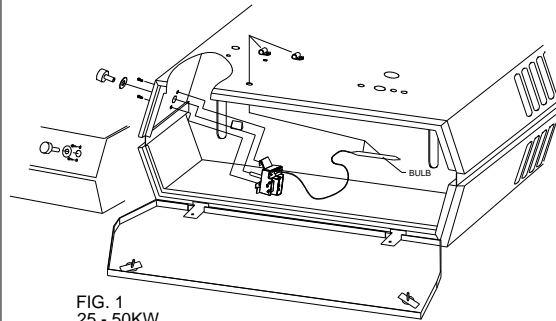

FIG. 1
25 - 50KW

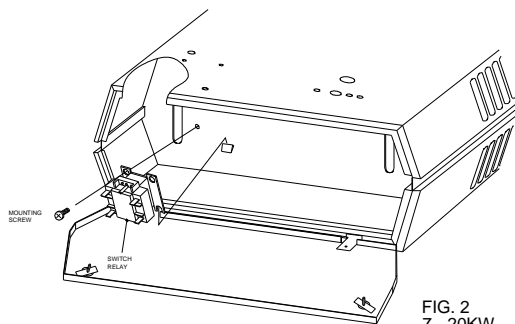

FIG. 2
7 - 20KW

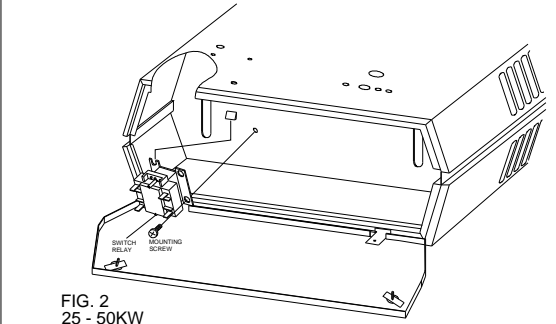

FIG. 2
25 - 50KW

- 7.) Install knob by pushing onto thermostat shaft.
- 8.) Connect lead wires from the thermostat to the control terminal board as shown in the wiring diagrams located on the inside of the control panel door.
- 9.) Set thermostat for desired turn on temperature. Rotate thermostat knob fully clockwise. When the room temperature has reached the comfort level turn thermostat counterclockwise until it clicks off. The thermostat may require one or two additional settings to maintain your desired comfort level.

HEAT RECOVERY THERMOSTAT TC5102 AND TC5103

- 10.) The TC5102 thermostat package requires a relay to operate the fan motor. Install the thermostat by following steps 1 through 8.
- 11.) Install the relay by slipping extended relay leg under mounting lip on control panel. Mount relay with one No. 8 screw as shown in Fig. 2. Each lead wire is marked for proper terminal location; connect lead wires as indicated on the wiring diagram located on the inside of the control panel door.
- 12.) Set the thermostat for desired turn on temperature for fan control.

Instructions d'Installation

SERIES TASKMASTER

Nécessaires de thermostat incorporés T5100, T5102, T5122, TC5102 et TC5103 (pour être installés sur place les radiateurs de séries 5100)

Le T5100, Unipolaire à une direction (SPST), contrôle la tension de ligne pour les radiateurs monophasés jusqu' à 277V, 25A.

o u

veilleuse (24-277 volts) pour les radiateurs munis de contacteurs.

Le T5102, bipolaire contrôle la tension de ligne interrompant tous les conducteurs non mis à la terre pour les radiateurs monophasés jusqu' à 277V, 25A

o u

bipolaire à une direction pour les radiateurs tripolaires jusqu' à 240V, 25A mais n' interrompant pas tous les conducteurs non mis à la terre pour les applications triphasées.

Le T5122, a un contrôle basse tension (24V) à 2 étages pour radiateur à 2 étages. Les deux circuits sont séparés et contrôlés par le même élément sensitif. Les interrupteurs contrôlant ces circuits sont calibrés pour ouvrir et fermer en série.

Le TC5102 est un relais/thermostat qui est utilisé avec des radiateurs de 480 & 600 volts pour contrôler le moteur du ventilateur. Il sert à détecter l' arrivée de la chaleur (therm.de strat.) au plafond et à faire démarrer le moteur du ventilateur pour faire recirculer accumulation de chaleur.

Le TC5103 sert à contrôler le moteur du ventilateur sur les radiateurs de 208, 240 & 277 volts pour faire recirculer la chaleur stratifiée accumulée au plafond.

Lisez S.V.P. chaque instruction d'installation soigneusement avant de commencer l'installation.

INSTRUCTIONS D'INSTALLATION DES T5100, T5102 & T5122

1.) ATTENTION:

Afin d'éviter un choc électrique possible, mettez le radiateur à la position ARRÊT au niveau du panneau de distribution. Sur les radiateurs équipés d'un interrupteur de courant, mettez l'interrupteur à la position ARRÊT.

2.) Desserez les deux vis situées sur la porte du panneau de contrôle et laissez celle-ci pendre. Quelques modèles ont un dispositif d'arrêt supplémentaire. Comprimez ce dispositif afin qu'il s'ouvre.

3.) Enlevez la rondelle défonçable de dia. $\frac{1}{2}$ " (13mm) alimentant l'ampoule du thermostat Fig. 1 afin de connecter celle-ci par le trou ainsi fait.

ATTENTION: Gardez le tube capillaire loin des dispositifs et des fils électriques internes.

4.) Enlevez les 2 petites rondelles défonçables pour les attaches des ampoules du thermostat à l'arrière du radiateur, (voir Fig. 1.) Insérez les deux attaches fournies. Agrafez les ampoules sur les attaches.

5.) Enlevez le papier du dos de l'étiquette (fournie). Alignez l'étiquette sur le trou de l'arbre du thermostat et positionnez-la (voir Fig. 1.) Collez l'étiquette sur le côté du radiateur comme montré.

6.) Notez l'orientation de la patte sur le support du thermostat. (voir Fig. 1.) Positionnez-la comme montré seulement. Installez le thermostat avec les 2 vis de montage No. 8 fournies.

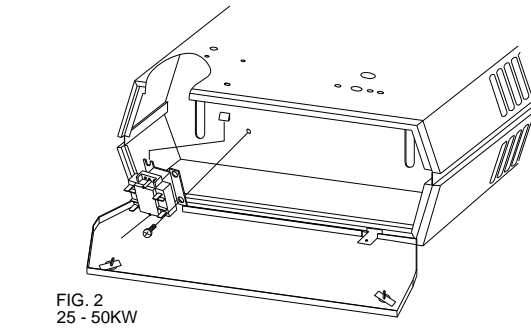
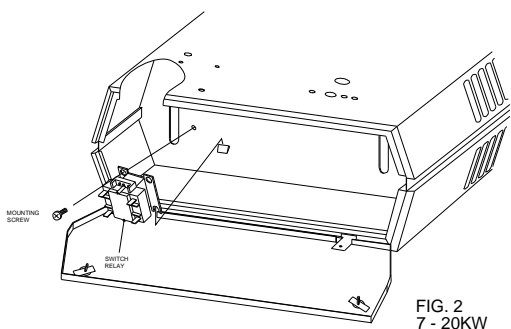
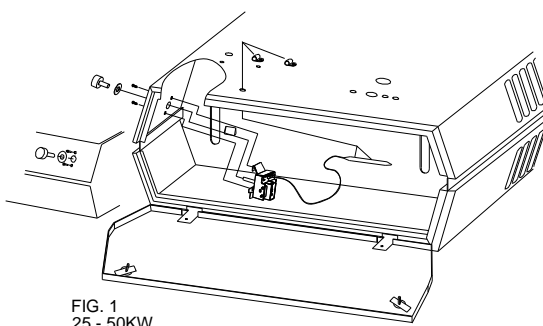
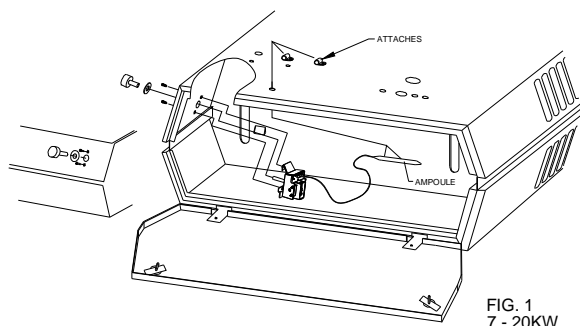
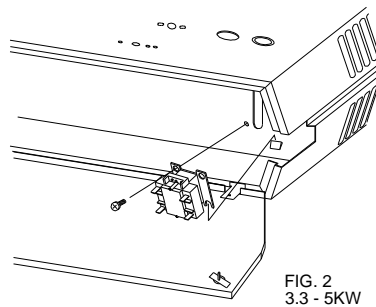
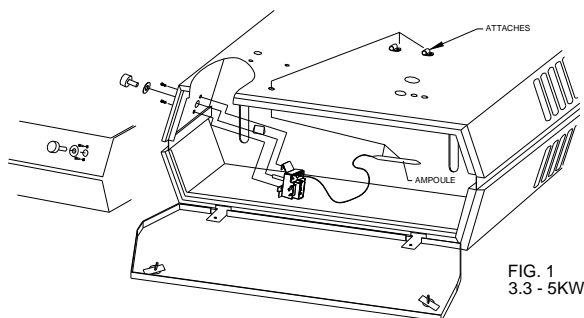

- 7.) Installez le bouton en le poussant sur l'arbre du thermostat.
- 8.) Connectez les fils conducteurs du thermostat aux bornes de contrôle comme montré sur les schémas de filerie situés à l'intérieur de la porte du panneau de contrôle.
- 9.) Réglez le thermostat à la température désirée. Tournez le thermostat à fond dans le sens des aiguilles d'une montre. Lorsque la température de la pièce a atteint le niveau désiré tournez le thermostat dans le sens contraire des aiguilles d'une montre jusqu'à ce qu'il s'ouvre (déclique). Le thermostat doit peut être, être réglé de nouveau une à deux fois afin de maintenir une température confortable.

THERMOSTAT À RÉCUPÉRATION DE CHALEUR TC5102 & TC5103

- 10.) Le thermostat monté TC5102 doit être muni d'un relais afin de faire fonctionner le moteur du ventilateur. Installez le thermostat en suivant les paragraphes de 1 à 8.
- 11.) Installez le relais en glissant sa patte sous le rebord de montage du panneau de contrôle. Montez le relais avec une vis No. 8 comme montré sur la Fig. 2. Chaque fil conducteur est marqué pour être connecté correctement; Connectez les fils conducteurs comme indiqué sur le schéma de filerie situé à l'intérieur de la porte du panneau de contrôle.
- 12.) Réglez le thermostat de nouveau pour contrôler le ventilateur, si vous désirez une autre température que celle réglée à la fabrique.

SERIES 5100 TASKMASTER

Installation Instructions

FS5102 ● TASKMASTER SERIES
UNIT MOUNTED LINE VOLTAGE SUMMER FAN SWITCH
FOR USE ON EITHER 480 OR 600 VOLT SUPPLY

READ THESE INSTRUCTIONS CAREFULLY BEFORE INSTALLING SWITCH. BE SURE TO DE-ENERGIZE POWER SOURCE TO UNIT BEFORE INSTALLING SWITCH. BE SURE TO INSTALL THE APPROPRIATE MODEL SWITCH ON THE CORRECT UNIT.

- 1.) Disconnect heater from supply.
- 2.) Remove appropriate knockouts for switch being used. Refer to Fig. 1.

Models 5102 thru 5105 - Fig. 2

Knockout group is located on heater back center approximately 1 1/8" (29mm) from bottom of heater.

Models 5107 thru 5120 - Fig. 3

Knockout group is located on heater back approximately 3 1/4" (83mm) from bottom of heater with the 9/16" (14mm) diameter knockout located approximately 3 3/4" (95mm) to the right of the back center.

Models 5125 thru 51100 - Fig. 4

Knockout group is located on heater back approximately 1 3/4" (44mm) from bottom of heater with the 9/16" (14mm) diameter knockout located approximately 5" (127mm) to the left of the back center.

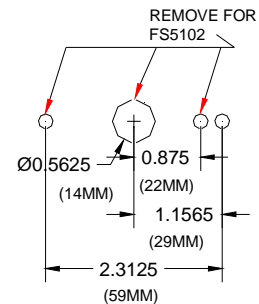

FIG. 1

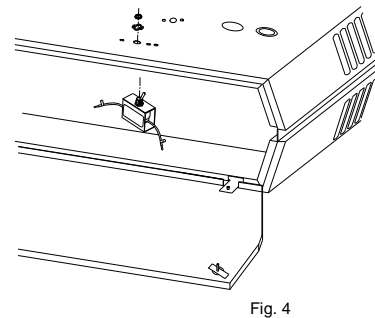
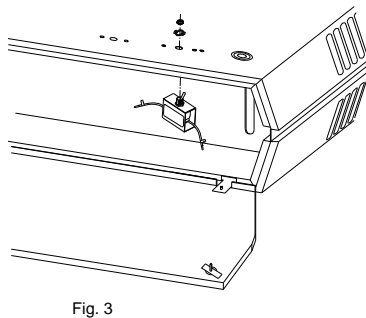
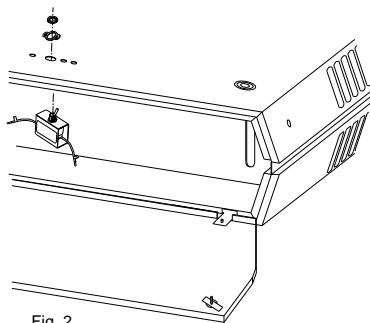

Fig. 2

Fig. 3

Fig. 4

- 3.) Remove paper backing from "Fan-Heat" decal, align with large knockout hole and affix to heater back with "Heat" toward bottom of heater.
- 4.) Attach switch bracket assembly to heater back with the two No. 8 sheet metal screws supplied.
- 5.) Push knob on switch shaft and check alignment with decal.
- 6.) Wire switch according to wiring diagram located on inside of heater bottom panel. Attach switch leads 7 & 9 to terminals 7 & 9 on terminal board.
- 7.) After installation is complete, restore power and check for proper operation.
Note: For summer fan operation only, place thermostat in OFF position.

Form 56628-008
ECO 1-5719

SERIES 5100 TASKMASTER

Installation Instructions

FS5102 ● TASKMASTER SERIES
UNIT MOUNTED LINE VOLTAGE SUMMER FAN SWITCH
FOR USE ON EITHER 480 OR 600 VOLT SUPPLY

READ THESE INSTRUCTIONS CAREFULLY BEFORE INSTALLING SWITCH. BE SURE TO DE-ENERGIZE POWER SOURCE TO UNIT BEFORE INSTALLING SWITCH. BE SURE TO INSTALL THE APPROPRIATE MODEL SWITCH ON THE CORRECT UNIT.

- 1.) Disconnect heater from supply.
- 2.) Remove appropriate knockouts for switch being used. Refer to Fig. 1.

Models 5102 thru 5105 - Fig. 2

Knockout group is located on heater back center approximately 1 1/8" (29mm) from bottom of heater.

Models 5107 thru 5120 - Fig. 3

Knockout group is located on heater back approximately 3 1/4" (83mm) from bottom of heater with the 9/16" (14mm) diameter knockout located approximately 3 3/4" (95mm) to the right of the back center.

Models 5125 thru 51100 - Fig. 4

Knockout group is located on heater back approximately 1 3/4" (44mm) from bottom of heater with the 9/16" (14mm) diameter knockout located approximately 5" (127mm) to the left of the back center.

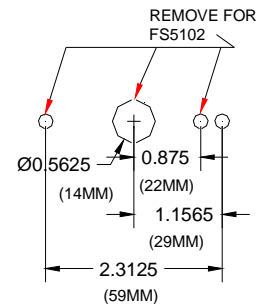

FIG. 1

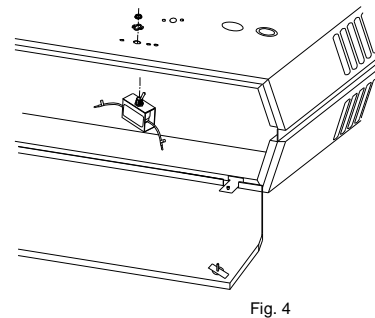
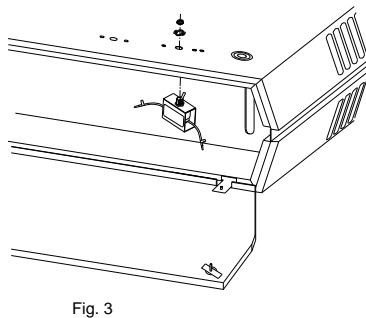
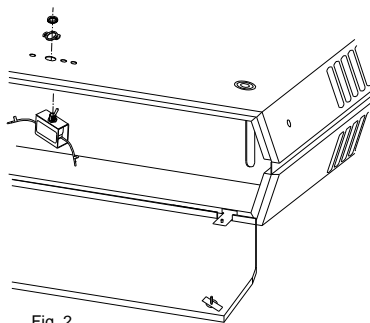

Fig. 2

Fig. 3

Fig. 4

- 3.) Remove paper backing from "Fan-Heat" decal, align with large knockout hole and affix to heater back with "Heat" toward bottom of heater.
- 4.) Attach switch bracket assembly to heater back with the two No. 8 sheet metal screws supplied.
- 5.) Push knob on switch shaft and check alignment with decal.
- 6.) Wire switch according to wiring diagram located on inside of heater bottom panel. Attach switch leads 7 & 9 to terminals 7 & 9 on terminal board.
- 7.) After installation is complete, restore power and check for proper operation.
Note: For summer fan operation only, place thermostat in OFF position.

Form 56628-008
ECO 1-5719

SERIES 5100

TASKMASTER

FSW5111 • TASKMASTER SERIES
REMOTE (WALL MOUNT) SUMMER FAN SWITCH

LINE VOLTAGE SWITCH FOR USE ONLY ON TASKMASTER HEATERS WITH A POWER SUPPLY OF 208, 240 or 277 VOLT SERVICE.

READ THESE INSTRUCTIONS CAREFULLY BEFORE INSTALLING SWITCH. DO NOT USE THIS SWITCH ON UNITS WITH 480 or 600 VOLT MOTOR CIRCUIT. BE SURE TO DEENERGIZE POWER SOURCE TO UNIT BEFORE INSTALLING SWITCH. ALL CONDUCTORS FROM SWITCH TO UNIT MUST BE COPPER. ALL WIRING TO BE IN ACCORDANCE WITH THE NATIONAL ELECTRIC CODE (NEC) AND EXISTING LOCAL CODE REQUIREMENTS.

- 1) Disconnect heater from power supply.
- 2) Remove $\frac{7}{8}$ " dia. knockout from heater back for control wiring from switch.
Models 5102 thru 5105
 $\frac{7}{8}$ " dia. knockouts located $2\frac{1}{2}$ " to right of heater back center and $3\frac{5}{16}$ " from bottom of heater.
Models 5107 thru 5120
 $\frac{7}{8}$ " dia. knockout is located $5\frac{1}{2}$ " to left of heater back center and $1\frac{1}{2}$ " from bottom of heater.
Models 5125 thru 5150
 $\frac{7}{8}$ " dia. knockout is located $5\frac{1}{16}$ " left of heater back center and $3\frac{5}{8}$ " from bottom of heater.
- 3) Mount switch bracket assembly in remotely located utility box by others with appropriate cover. Note location of "top" of switch bracket.
- 4) Wire switch according to wiring diagram located on inside of heater bottom panel. Attach leads 7 & 9 from switch to heater terminals 7 & 9 on heater terminal board.
- 5) Assemble cover to utility box.
- 6) Assemble knob to switch shaft.
- 7) Remove paper backing from "Heat-Fan" decal and affix to utility box cover above switch knob.
- 8) After installation is complete, restore power to heater and check for proper operation.

NOTE: For summer fan operation only thermostat must be in OFF position.

SERIES 5100

TASKMASTER

Installation Instructions

FOR RADIAL DIFFUSER

MODEL RD5120 USE WITH 5107-5120 UNITS
MODEL RD5150 USE WITH 5125-5150 UNITS
MODEL RD5175 USE WITH 5155-5175 UNITS

READ THESE INSTRUCTIONS CAREFULLY BEFORE INSTALLATION. BE SURE TO DE-ENERGIZE POWER SOURCE TO UNIT BEFORE INSTALLING DIFFUSER. CHECK MODEL NUMBER TO INSURE INSTALLATION ON PROPER SIZE UNIT.

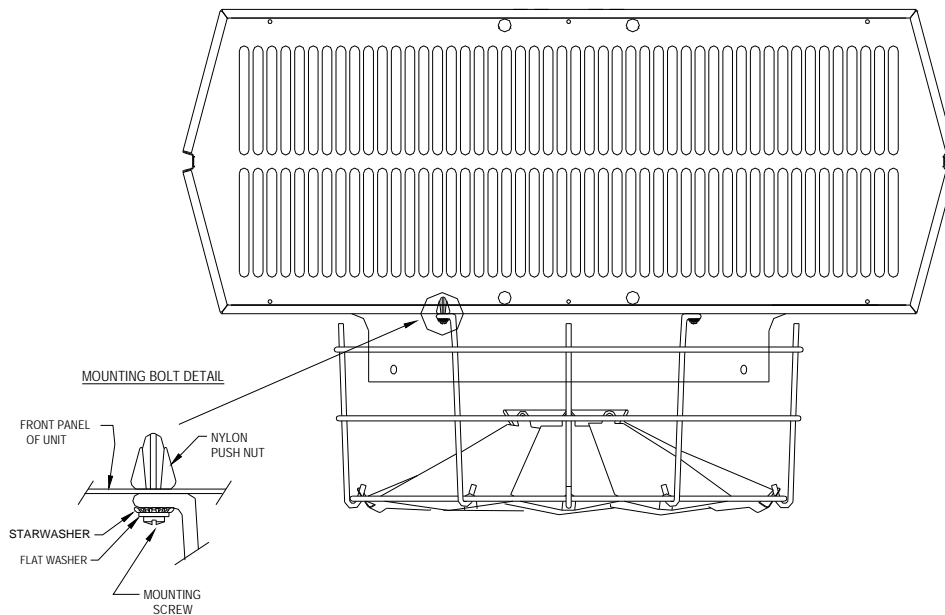

- 1.) Disconnect heater from supply.
- 2.) Immerse nylon push nuts in water for at least 1/2 hour before installing.
- 3.) Remove louver frame assembly from front of heater and discard. (Louver frame assembly is attached to the heater front with four sheet-metal screws.)
- 4.) Insert the four nylon push nuts provided into the square holes located around the venturi opening on the heater front. A slight tap with a flat surface may be required to fully seat the nylon push nuts into the square holes.
- 5.) Assemble the star washers and flat washers provided onto each of the mounting screws as shown.
- 6.) Line up the diffuser mounting holes with the nylon push nuts mounted in the heater front (step 2). Insert the mounting screws (step 3) through the diffuser mounting eyelets and tighten screws.
- 7.) Adjust the diffuser vanes for desired air deflection.
- 8.) Restore power to place heater in operation.

FORM: 56628-011
ECO 1-5719

SERIES 5100
TASKMASTER

INSTALLATION INSTRUCTIONS

ANEMOSTAT DIFFUSER ● TASKMASTER SERIES

MODEL AD5120 USE WITH 5107-5120 UNITS

MODEL AD5150 USE WITH 5125-5150 UNITS

MODEL AD5175 USE WITH 5155-5175 UNITS

READ THESE INSTRUCTIONS THOROUGHLY BEFORE INSTALLING DIFFUSER. BE SURE TO DE-ENERGIZE POWER SOURCE TO UNIT BEFORE INSTALLING DIFFUSER. CHECK MODEL NUMBER OF DIFFUSER TO INSURE INSTALLATION ON PROPER SIZE UNIT.

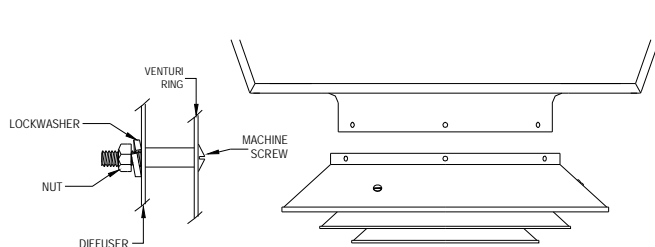

FIG. 1

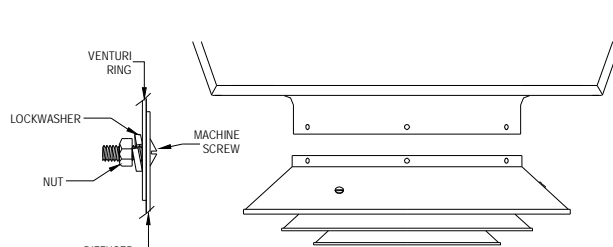

FIG. 2

For Heaters 5107-5110 Use Diffuser AD5120 - See Fig. 1

For Heaters 5125-5150 Use Diffuser AD5150 - See Fig. 1

For Heaters 5155-5175 Use Diffuser AD5175 - See Fig. 1

- 1.) Discard 1/4-20 X 1/2" (13mm) long machine screws (bag assembly).
- 2.) Line up holes in diffuser and the venturi ring on the heater front.
- 3.) Insert the 1/4-20 x 1" (25mm) long machine screws through the venturi ring holes with the machine screw head on the *inside* of the venturi (**See Note Below**).
- 4.) Slip the spacer (1/4" (6mm) for models 5155-5175 and 5/8" (16mm) for all others listed above) over the machine screw. Insert the machine screw through the diffuser hole, install the lockwasher, nut; then tighten. (See detail above). (Three places)
- 5.) Place heater in operation.

For Heaters 5112-5120 Only Use Diffuser AD5120 - See Fig. 2

- 1.) Discard 1/4-20 X 1" (25mm) long machine screws and 5/8" (16mm) long spacers.
- 2.) Line up holes in diffuser and venturi ring (heater front).
- 3.) Insert 1/4-20 x 1/2" (13mm) long machine screws through venturi ring and diffuser holes with the machine screw head on the *inside* of the venturi (**See Note Below**).
- 4.) Attach the lockwasher, nut and tighten. (See detail above) (Three places).
- 5.) Place unit in operation.

NOTE

- 1.) Machine screw heads *must* be on the *inside* of the venturi ring.
- 2.) Caution must be exercised when mounting the diffuser so as not to damage the fan blade.

SERIES 5100

TASKMASTER

Installation Instructions

DCS323, DCS632, DCS 633 POWER DISCONNECT SWITCH • TASKMASTER SERIES

RATING	DCS323	3 POLE	32 AMPS	600 VAC RESISTIVE
	DCS632	2 POLE	63 AMPS	600 VAC RESISTIVE
January 1990	DCS633	3 POLE	63 AMPS	600 VAC RESISTIVE

WARNING: Open supply circuit disconnect switch before servicing unit. Failure to do so may result in personal injury or death from electrical shock.

NOTE: Before installing disconnect switch, check heater data tape to ensure that heater electrical rating does not exceed the switch electrical rating.

NOTE: All wiring must be done in accordance with National and Local Electrical Codes. Supply conductors to unit must be copper.

NOTE: The power disconnect switch kits may be either of two types. Determine which type you have and follow the appropriate instructions.

DISCONNECT SWITCHES WITH TERMINAL SHIELD. REFER TO FIGURES 1 AND 2 .

1. Disconnect heater from power supply.
2. Locate and remove large knockout and two adjacent small knockouts from heater where switch is to be mounted.

- a. 7-20 KW Units — 5/8" wide knockout slot is located centered on the heater back approximately 3 1/2" from the bottom of the unit with a small knockout on each side. See Figure 1.

NOTE: In some instances due to restricted space in the control compartment of 480 and 600 volt heaters, the disconnect switch accessory model DCS633 must be mounted to the cabinet front using three knockouts (a 1/2" with a 3/16" on each side) located on front left 2 1/2" from bottom.

- b. 25-50 KW Units — 13/32" diameter knockout is located on left hand side of heater front with the small knockout on either side. See Figure 2.

3. Remove paper backing from "ON-OFF" decal and affix it to heater above large knockout hole with lettering toward top of heater.
4. Attach switch bracket assembly to heater with the two No. 8 screws provided.

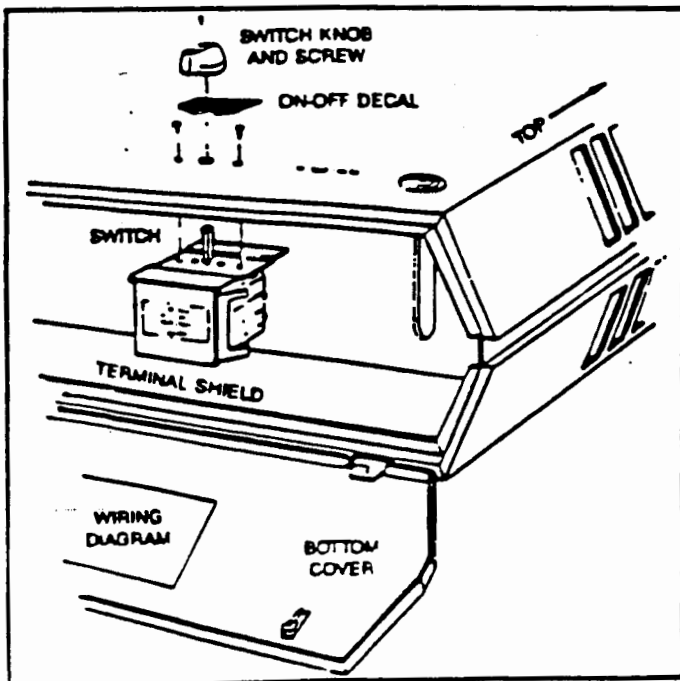

FIGURE 1 - Switch Location on 7-20 KW Unit

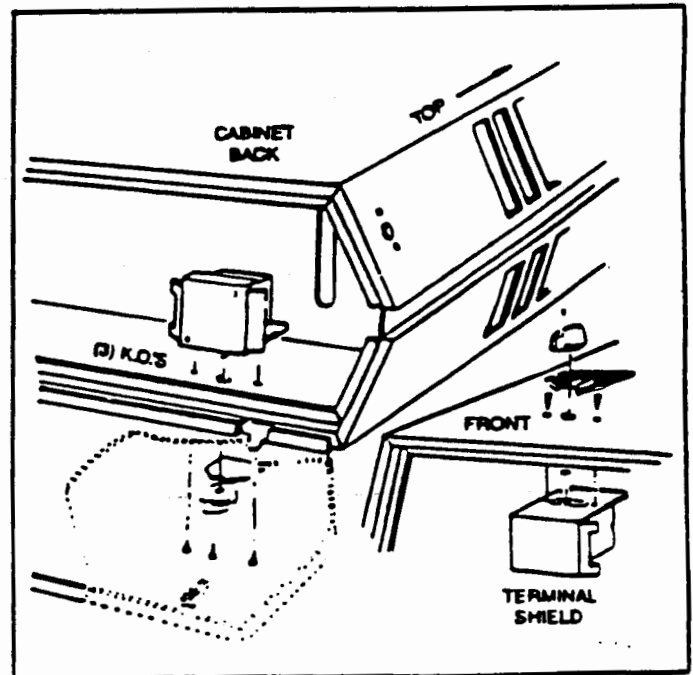

FIGURE 2 - Switch Location on 25-50 KW Unit

9581

NOTE: Switch bracket assembly must be attached to heater with switch terminal barrier section toward bottom of heater; data and caution tapes on switch bracket must be plainly visible after installation. Do not remove fiber barrier from switch mounting bracket.

5. Loosen switch knob screw, push knob on switch, check for proper alignment with "ON-OFF" decal and tighten knob screw. When the switch shaft is turned fully counterclockwise, the switch will be in the "OFF" position.
6. Wire switch according to wiring diagram located on inside of heater bottom cover.
 - a. Attach switch leads T1, T2 and T3 to L1, L2 and L3 of heater terminal block.
 - b. Attach switch leads L1, L2 and L3 to incoming conductors L1, L2 and L3 by suitable means.

NOTE: Switch Model DCS632 has lads marked T1, T2 and L1, L2 only.

DISCONNECT SWITCH KITS WITHOUT TERMINAL SHIELD. REFER TO FIGURES 3 and 4.

1. Refer to steps 1 and 2 from above instructions.
2. Remove the knob from the switch by loosening the screw in the center of the knob and pulling it off.

3. Connect the incoming power supply leads to terminals L1 - L2 - L3 of the disconnect switch. Connect the incoming ground lead to the grounding screw (or lug). On some models with adequate access the switch may be mounted (step 4) prior to connecting the supply wiring.
4. Mount the switch inside the heater control compartment, with the shaft extending through the knockout, using the two #8 x 5/16" phillips head screws provided. The switch should be oriented so the side with the data label is facing the open side of the compartment (visible when installed). Be careful to position all electrical wiring so that it is not pinched or otherwise damaged.
5. Connect the leadwires on the switch, marked T1 - T2 - T3 to the heater power terminal block marked L1 - L2 - L3. Switch model DCS632 will have only leadwires marked T1 - T2 and L1 - L2.
6. Install the knob and tighten the screw.
7. Attach the "ON-OFF" decal located per Figure 3. Peel off the backing paper, position carefully then press firmly onto the heater cabinet. Note that knob rotation clockwise is "ON" and counterclockwise is "OFF."
8. Check all connections for tightness and electrical clearances. Close cover and latch, then restore electrical power and check heater in each mode of operation.

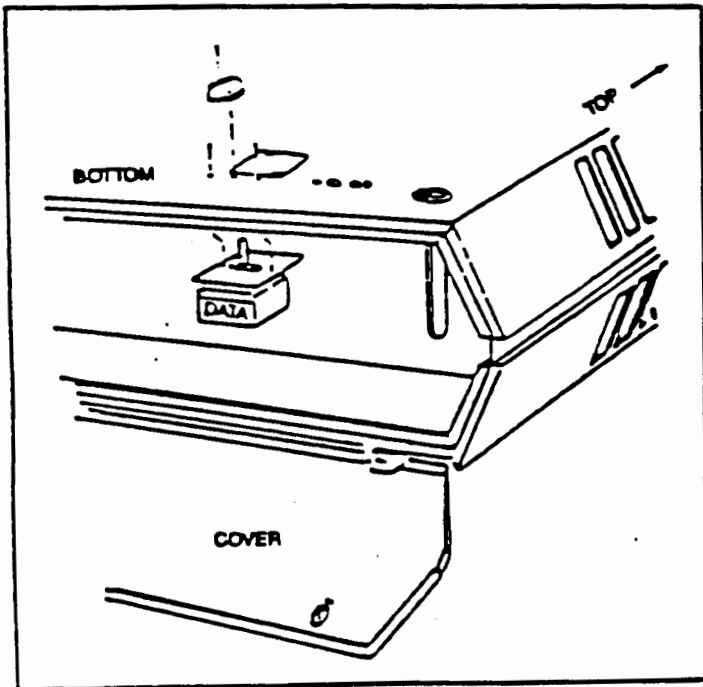

FIGURE 3 - Switch Location on 7-20 KW Unit

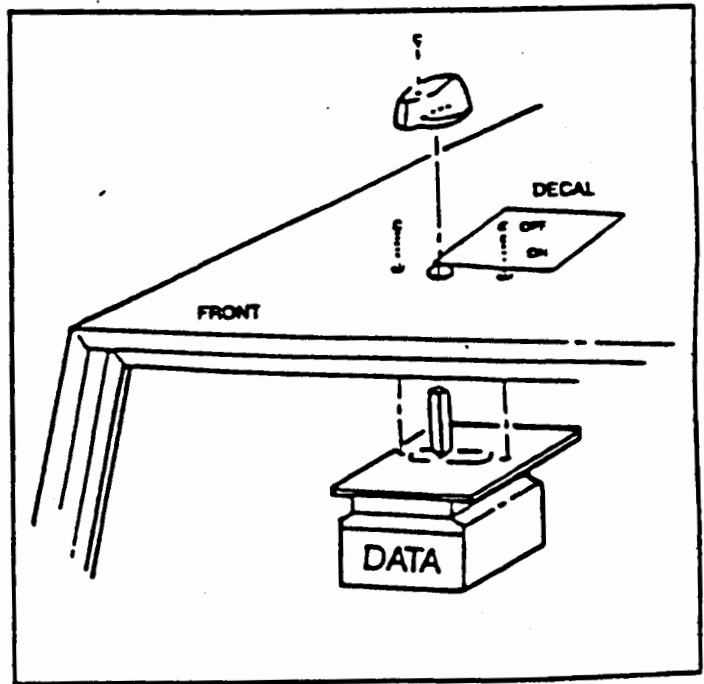

FIGURE 4 - Switch Location on 25-50 KW Unit