

Circuit & Motor Protection

Fuse Blocks & Fuse Holders	2
C350 Series	4
Circuit Breakers	5
Universal Molded Case Circuit Breakers	9
Series G® Molded Case Circuit Breakers	12
Type QC Miniature Circuit Breakers	18
WMZT UL 489 Miniature Circuit Breakers	25
WMS UL 1077 Miniature Circuit Breakers	26
SPHM Series Hydraulic Magnetic Circuit Breakers	29
J Series Hydraulic Magnetic Circuit Breakers	30
AMR Series Hydraulic Magnet Circuit Breakers	31
Series NRX™ Low Voltage Power Breaker	32
Magnum® Low Voltage Power Breaker	35
Manual Motor Protectors & Controllers	40
XT IEC Manual Motor Protectors	42
XT IEC Combination Motor Controllers	49
Rotary Disconnect Switches	52
Open Rotary Disconnect Switches	55
Enclosed Rotary Disconnect Switches	57
Overload Relays	61
XT IEC Miniature Overload Relays	63
XTOB, XTOT Thermal Overload Relays	64
C396 Electronic Overload Relays	67
Motor Insight™ Overload and Monitoring Relays	69

Higher AIC, Less Space

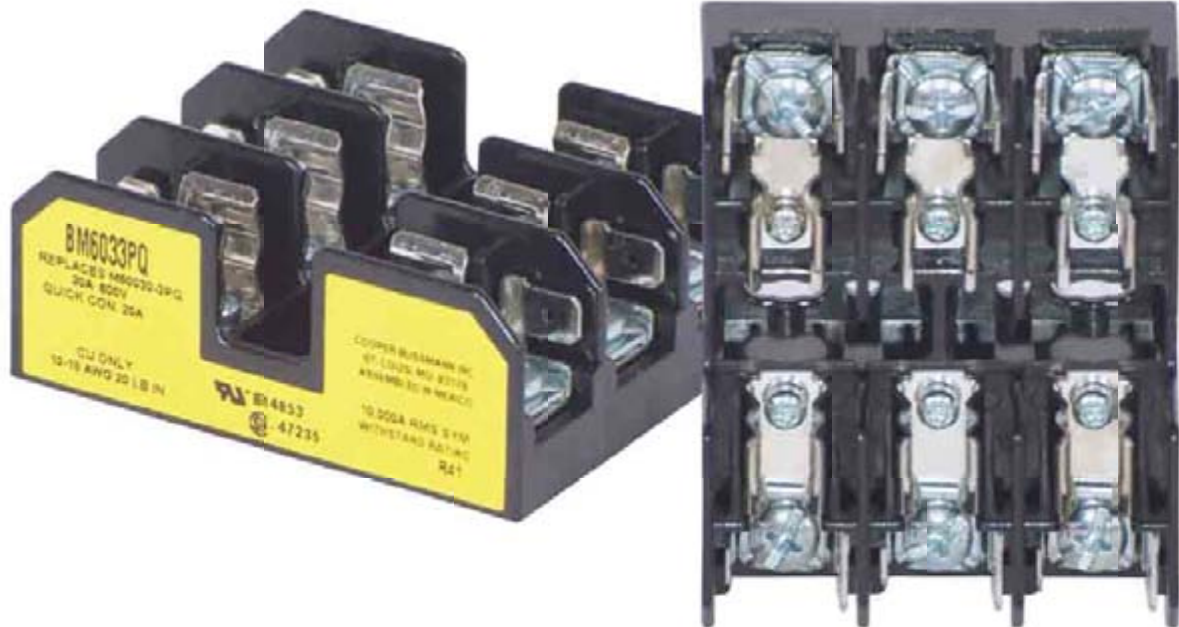

Powering Business Worldwide

- Secure higher AIC with these space-saving solutions for circuit protection
- Interlocking DIN mount fuse blocks provide multiple poles with one part
- Improper fuse rejection feature prevents insertion of lower interruption fuses

Circuit & Motor Protection

Fuse Blocks & Fuse Holders

PRODUCT OVERVIEW

Fuse Blocks & Fuse Holders Product Overview

	
Description	C350
Page	Page 4
Number of Poles	Up to 3
Mounting	35 mm Flat or 32 mm Asymmetrical DIN-Rail (with optional adapter)
Terminal Ratings	600V, 30A
Housing Construction	Thermoplastic UL 94V0 Flammability Rating
Clip / Terminal Construction	Tin-Plated Copper Alloy
Screw / Pressure Plate Construction	Zinc-Plated Steel
Certifications	UL, CSA
Dielectric Strength	1200V

Circuit & Motor Protection

Fuse Blocks & Fuse Holders

PRODUCT SELECTION

C350 Series Fuse Blocks & Fuse Holders

- Space-saving design
- Rated 600V, 30A
- UL approved for motor loads



Fuse Blocks & Fuse Holders

Wire Termination	No. of Poles	250V				600V			
		30A		60A		30A		60A	
		Catalog Number	Carton Qty.	Catalog Number	Carton Qty.	Catalog Number	Carton Qty.	Catalog Number	Carton Qty.

Class H Fuse Holders

Single Collar (Box Lug) — Sized to Ampere Rating	1	W231HA	10	W261HA	10	W631HA	10	W661HA	1
	2	W232HA	5	W262HA	5	W632HA	5	W662HA	1
	3	W233HA	5	W263HA	5	W633HA	1	W663HA	2

Class M Fuse Holders

Combination of Double Quick-Connect, 20A Max., and Binding Head Screw, #10 Max., Cu/Al	1	—	—	—	—	WM631F	10	—	—
	2	—	—	—	—	WM632F	8	—	—
	3	—	—	—	—	WM633F	6	—	—
Combination of Double Quick-Connect, 20A Max., and Pressure Plate Screw, #10 Max., Cu Only	1	—	—	—	—	WM631G	10	—	—
	2	—	—	—	—	WM632G	8	—	—
	3	—	—	—	—	WM633G	6	—	—

Class R Fuse Holders

Single Collar (Box Lug) — Sized to Ampere Rating	1	WR231HA	10	—	—	WR631HA	10	—	—
	2	—	—	—	—	WR632HA	5	—	—
	3	WR233HA	5	WR263HA	1	WR633HA	5	WR663HA	5
Combination of Double Quick-Connect, 20A Max., and Binding Head Screw, #10 Max., Cu/Al	1	—	—	—	—	—	—	—	—
	2	—	—	—	—	WMR632F	1	—	—
	3	—	—	—	—	WMR633F	6	—	—
Combination of Double Quick-Connect, 20A Max., and Pressure Plate Screw, #10 Max., Cu Only	1	—	—	—	—	WMR631G	10	—	—
	3	—	—	—	—	WMR633G	6	—	—

Class R Fuse Holder, Type WRR Control Transformer Fuse Block

Combination of Double Quick-Connect, 20A Max., and Pressure Plate Screw, #14 – #10 Cu Only	3	—	—	—	—	WRR633G	6	—	—
--	---	---	---	---	---	----------------	---	---	---

Smaller Size, Greater Power



Powering Business Worldwide



- High interruption power breakers for high performance equipment
- Compact and globally certified molded case circuit breakers for main feeds
- Broadest line of industrial miniature circuit breakers for branch applications
- AC/DC hydraulic magnetic circuit breakers for extreme environmental conditions
- Broadest set of SCCR combinations ratings listed under UL 508A

Circuit & Motor Protection

Circuit Breakers

PRODUCT OVERVIEW

Circuit Breakers Product Overview

					
Description	Universal Molded Case Circuit Breaker	Series G Molded Case Circuit Breaker	QUICKLAG Type QC Miniature Circuit Breaker		
Page	Page 9	Page 12	Page 18		
General Applications	Line protection — feeder and branch thermal-magnetic trip unit.	Line protection — molded case switch, motor circuit protection (combination tested with Eaton starters and contactors) thermal-magnetic and electronic trip units.	Used to provide branch circuit protection in cable-in/out panel or DIN-Rail mount applications.		
Maximum Current Rating	400A	630A	100A		
Maximum Voltage — ac	480/277V ac	690V ac	240V ac		
Maximum Voltage — dc	—	125/250V dc	80V dc		
Poles	1, 2, 3	1, 2, 3, 4	QC = 1, 2, 3, 4 QCD = 1, 2, 3 QCR/QCF = 1, 2, 3		
Approvals	UL 489 IEC 60947-2 CE CSA	UL 489 IEC 60947-2 CE CSA KEMA-KEUR CCC	UL 489 CSA 22.2		
Max. Interrupting Capacities (see individual catalogs for limitations and back-up protection requirements)	@ 240V G = 25 kA (480/277) F = 25 kA J = 25 kA K = 25 kA	@ 480V G = 14 kA (480/277) F = 18 kA J = 20 kA K = 20 kA	@ 240V E = 200 kA J = 200 kA L = 200 kA	@ 480V E = 100 kA J = 200 kA L = 200 kA	65 kA @ 240V ac 5 kA @ 80V dc



Environmental Data

Humidity	—	—	—
Shock	—	—	—
Vibration	—	—	—
Operating Temperature	-20°C to +70°C (-4°F to +158°F)	-20°C to +70°C (-4°F to +158°F)	40°C (104°F)
Dielectric Strength	8 kV	8 kV	1960V ac (acc. to UL 489)
Insulation Resistance	—	—	—
Endurance / Life	250A: 10,000 Operations 400A: 8,000 Operations	250A: 10,000 Operations 630A: 8,000 Operations	>10,000 Operations
Approximate Weight	G 3-Pole – 2.10 lbs (0.95 kg) F 3-Pole – 4.5 lbs (2.0 kg) J 3-Pole – 12.50 lbs (5.7 kg) K 3-Pole – 11.50 lbs (5.2 kg)	E 3-Pole – 2.88 lbs (1.04 kg) J 3-Pole – 5.06 lbs (2.30 kg) L 3-Pole – 12.36 lbs (5.61 kg)	QC 1-Pole – 0.36 lbs (162.8 g) QC 2-Pole – 0.61 lbs (274.9 g) QC 3-Pole – 1.14 lbs (518.3 g) QCD 1-Pole – 0.43 lbs (195.3 g) QCD 2-Pole – 0.89 lbs (401.9 g) QCD 3-Pole – 1.34 lbs (605.6 g) QCR 1-Pole – 0.22 lbs (97.9 g) QCR 2-Pole – 0.48 lbs (215.8 g) QCR 3-Pole – 0.70 lbs (315.6 g) QCF 1-Pole – 0.24 lbs (109.9 g) QCF 2-Pole – 0.50 lbs (225.2 g) QCF 3-Pole – 0.74 lbs (335.1 g)
Mounting Configuration	Backpan, DIN-Rail (G)	Backpan, Plug-In Adapter, 35 mm DIN-Rail (E)	Panel Mount, Front Mount, 35 mm DIN-Rail Mountable
For more detailed information, see Distribution Products Catalog, CA08101001E.	Tab 12	Tab 12	Tab 11

Circuit & Motor Protection

Circuit Breakers PRODUCT OVERVIEW

Circuit Breakers Product Overview

			
Description	WMZT DIN-Rail UL 489 Miniature Circuit Breaker	WMS Supplementary Protectors	SPHM Hydraulic Magnetic Circuit Breaker
Page	Page 25	Page 26	Page 29
General Applications	Used to provide branch circuit protection in cable-in / out DIN-Rail mount applications.	Used to provide overcurrent protection where branch protection (for example UL 489 MCCB) is already provided or not required. Replacement for fuses used as supplementary protectors.	Replacement for fuses used as supplementary protectors.
Maximum Current Rating	40A	60A	63A
Maximum Voltage — ac	480/277V ac (240/415V ac IEC)	480/277V ac	480V ac
Maximum Voltage — dc	48V dc	65V ac 1-Pole 130V ac 2-Pole	80V dc
Poles	1, 2, 3	1, 2, 3	1, 2, 3, 4
Approvals	UL 489 CE; IEC / EN 60947-2 CSA 22.2	UL 1077 CE; IEC / EN 60947-2; IEC/EN 60898 CSA 22.2 235	UL 1077 CE; EN 60947-2 CSA 22.2
Max. Interrupting Capacities (see individual catalogs for limitations and back-up protection requirements)	10 kA UL / CSA; 15 kA IEC / EN 60947-2	IEC 240/415V 10 kA UL/CSA 120V 10 kA 240V 10 kA 277V 6 kA 480V 6 kA	277V ac – 5000A 480V ac – 3000A 80V dc – 5000A

Environmental Data





Humidity	acc. IEC 60068-2 (25.. 55°C / 77...131°F, 90...95% RH)	—	IEC 68-2-3 and MIL-STD 202 Method 103 Test A
Shock	acc. IEC 60068-2-27 (40 g Half Sine Wave for 10 ms – 3 axes) (15 g Half Sine Wave for 20 ms – 3 axes)	—	IEC 68-2-27 MIL-STD 202, Method 213 Cond 1 (50 G, 6 ms)
Vibration	acc. to IEC 60068-2-6 5...100 Hz / 1.0 mm / 0.7 g (3 axes)	—	IEC 68-2-6 MIL-STD 202, Method 204 (10 to 500 Hz, 10 G Amplitude .06")
Operating Temperature	30°C / 86°F	—	-40°C to +85°C (-40°F to +185°F)
Dielectric Strength	1960V ac (acc. to UL 489)	—	3750V ac — 50/60 Hz
Insulation Resistance	100 MΩ at 500V dc	—	100 MΩ under 500V dc
Endurance / Life	>20,000 Operations	—	10,000 Switching Operations with 6,000 at Rated Current
Approximate Weight	1-Pole – 0.27 lbs (121.0 g) 2-Pole – 0.53 lbs (242.0 g) 3-Pole – 0.80 lbs (363.0 g)	1-Pole – 0.26 lbs (120.0 g) 2-Pole – 0.54 lbs (244.9 g) 3-Pole – 0.83 lbs (376.5 g)	1-Pole – .32 lbs (145.0 g) 2-Pole – .65 lbs (295.0 g) 3-Pole – .97 lbs (440.0 g) 4-Pole – 1.30 lbs (590.7 g)
Mounting Contribution	35 mm DIN-Rail Mountable	35 mm DIN-Rail Mountable	35 mm DIN-Rail Mountable
For more detailed information, see Distribution Products Catalog, CA08101001E	Tab 11	Tab 11	Tab 11

Circuit & Motor Protection

Circuit Breakers

PRODUCT OVERVIEW

Circuit Breakers Product Overview

				
Description	J Series Hydraulic Magnetic Circuit Breaker	AMR Hydraulic Magnetic Circuit Breaker	Series NRX Power Circuit Breaker	Magnum Power Circuit Breaker
Page	Page 30	Page 31	Page 32	Page 35
General Applications	Well suited for use where equipment must be kept as small as possible, like in crowded control panels. For use as a supplemental protector. No change in tripping performance in extreme ambient temperatures from -40°C to 85°C.	Most versatile hydraulic magnetic breaker for use in branch circuit applications or as a supplemental protector. No change in tripping performance in extreme ambient temperatures from -40°C to 85°C.	Solution for where space is at a premium or when equipment dimensions are critical when upgrading or retrofitting current systems. Offering the power and performance of a power breaker in the compact size of a molded case breaker. With its reduced weight and compact dimensions, you can mount two times as many feeder breakers and reduce the overall enclosure density up to 50%.	Designed and engineered for use in low voltage metal enclosed switchgear and power distribution enclosures of nominal voltage up to 600V ac.
Maximum Current Rating	50A	100A 300A (3 paralleled poles to operate as single pole)	630 – 1600A	800 – 6300A
Maximum Voltage — ac	415V ac	480V ac	220 – 690V ac	up to 635V ac
Maximum Voltage — dc	80V dc	125V dc	—	—
Poles	1, 2, 3, 4	1, 2, 3, 4	3, 4	3, 4
Approvals	UL 1077 / UL 489A CE; EN 60947-2 CSA 22.2	UL 1077 / UL 489 / UL 489A CE; EN 60934 CSA 22.2	UL 1006 Component UL 489 Component IEC 60947-2	UL 1066 ANSI 637 NEMA SG3 CSA 22.2
Max. Interrupting Capacities (see individual catalogs for limitations and back-up protection requirements)	277V ac – 5000A 415 V ac – 1500A (3 – 4-Pole) 80V dc – 1000A (UL 1077) 80V dc – 5000A (UL 489A)	UL 1077 – 80V dc – 7500A UL 1077 – 125V dc – 5000A UL 1077 – ac – 5000A UL 489 – 80V dc – 10,000A UL 489 – ac – 10,000A	65 kAIC at 480V ac Maximum Withstand Capacities 42 kAIC	100 kA at 635V ac 200 kA at 508V ac CL Fuseless 200 kA at 600V ac w/ Integral Limiters

Environmental Data

Humidity	IEC 68-2-3 and MIL-STD 202 Method 103 Test A	IEC 68-2-3 and MIL-STD 202 Method 103 Test A	—	—
Shock	IEC 68-2-27 MIL-STD 202, Method 213 Cond 1 (100 G, 6 ms or 50 G, 11 ms)	IEC 68-2-27 MIL-STD 202, Method 213 Cond 1 (100 G, 6 ms)	—	—
Vibration	IEC 68-2-6 MIL-STD 202, Method 204 (10 to 500 Hz, 10 G Amplitude .06")	IEC 68-2-6 MIL-STD 202, Method 204 (10 to 500 Hz, 10 G Amplitude .06")	—	—
Operating Temperature	-40°C to +85°C	-40°C to +85°C	—	—
Dielectric Strength	3750V ac – 50/60 Hz	3750V ac – 50/60 Hz	—	—
Insulation Resistance	100 MΩ under 500V dc	100 MΩ under 500V dc	—	—
Endurance / Life	10,000 Switching Operations with 6,000 at Rated Current	10,000 Switching Operations with 6,000 at Rated Current	10,000 Electrical Operations 20,000 Mechanical Operations	—
Approximate Weight	1-Pole – .143 lbs (65 g) 2-Pole – .309 lbs (140 g) 3-Pole – .463 lbs (210 g) 4-Pole – .617 lbs (280 g)	1-Pole – .220 lbs (100 g) 2-Pole – .441 lbs (200 g) 3-Pole – .661 lbs (300 g) 4-Pole – .882 lbs (400 g)	3-Pole Breaker + Cassette — 85 lbs (39 kg) 3-Pole Breaker — 53 lbs (24 kg) 4-Pole Breaker + Cassette — 104 lbs (47 kg) 4-Pole Breaker — 67 lbs (30 kg)	—
Mounting Contribution	Panel Mount, Snap-In Mount	Panel Mount, Snap-In Mount	Rear-Connected, Front-Connected, Surface Mounting, Mounting Bracket, Fixed, Drawout Breaker with Cassette	Fixed or Drawout (with cassette)
For more detailed information, see Distribution Products Catalog, CA08101001E.	Tab 11	Tab 11	Tab 13	Tab 13

Universal Molded Case Circuit Breakers

- Universal design for both NEMA (UL 489) and IEC (IEC 947-2) standards
- Suitable for 50°C application
- Factory-sealed thermal magnetic trip unit
- Standard interrupting ratings



Universal Molded Case Circuit Breaker — 3-Pole

Product Description	Amperes	Catalog Number ①
---------------------	---------	------------------

Series C G-Frame

3"W x 4-7/8"H x 2-13/16"D (includes mounting hardware and terminals) (optional DIN-Rail kit available catalog number GDIN, package of ten)	15	Gi3015						
	20	Gi3020						
	25	Gi3025						
	30	Gi3030						
	35	Gi3035						
	40	Gi3040						
	45	Gi3045						
	50	Gi3050						
	60	Gi3060						
	<table border="1"> <thead> <tr> <th>Voltage</th> <th>Interrupting Rating</th> </tr> </thead> <tbody> <tr> <td>380 – 415</td> <td>18/5K</td> </tr> <tr> <td>480/277</td> <td>14K</td> </tr> </tbody> </table>			Voltage	Interrupting Rating	380 – 415	18/5K	480/277
Voltage	Interrupting Rating							
380 – 415	18/5K							
480/277	14K							

Series C F-Frame

4-1/8"W x 6"H x 3-3/8"D (includes mounting hardware and terminals)	15	Fi3015L						
	20	Fi3020L						
	25	Fi3025L						
	30	Fi3030L						
	35	Fi3035L						
	40	Fi3040L						
	50	Fi3050L						
	60	Fi3060L						
	70	Fi3070L						
	80	Fi3080L						
	90	Fi3090L						
	100	Fi3100L						
	125	Fi3125L						
	150	Fi3150L						
	175	Fi3175L						
	200	Fi3200L						
225	Fi3225L							
<table border="1"> <thead> <tr> <th>Voltage</th> <th>Interrupting Rating</th> </tr> </thead> <tbody> <tr> <td>415V</td> <td>18/9K</td> </tr> <tr> <td>480</td> <td>14K</td> </tr> </tbody> </table>			Voltage	Interrupting Rating	415V	18/9K	480	14K
Voltage	Interrupting Rating							
415V	18/9K							
480	14K							

① Metric mounting hardware.

Product Description	Amperes	Catalog Number ①
---------------------	---------	------------------

Series C J-Frame

4-1/8"W x 10"H x 4-1/16"D (includes mounting hardware and terminals)	225	Ji3225L						
	250	Ji3250L						
<table border="1"> <thead> <tr> <th>Voltage</th> <th>Interrupting Rating</th> </tr> </thead> <tbody> <tr> <td>415</td> <td>25/13K</td> </tr> <tr> <td>480</td> <td>20K</td> </tr> </tbody> </table>			Voltage	Interrupting Rating	415	25/13K	480	20K
Voltage	Interrupting Rating							
415	25/13K							
480	20K							

Series C K-Frame

5-1/2"W x 10-1/8"H x 4-1/16"D (includes mounting hardware and terminals)	300	Ki3300L						
	350	Ki3350L						
	400	Ki3400L						
<table border="1"> <thead> <tr> <th>Voltage</th> <th>Interrupting Rating</th> </tr> </thead> <tbody> <tr> <td>415</td> <td>25/13K</td> </tr> <tr> <td>480</td> <td>20K</td> </tr> </tbody> </table>			Voltage	Interrupting Rating	415	25/13K	480	20K
Voltage	Interrupting Rating							
415	25/13K							
480	20K							

① Metric mounting hardware

Circuit & Motor Protection

Circuit Breakers

PRODUCT SELECTION

Universal Molded Case Circuit Breakers — Accessories

Internal Accessories

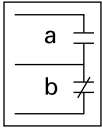
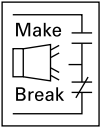
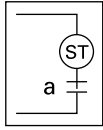
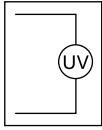
							
Auxiliary Switch (Right-Pole Mounted)		Bell Alarm (Right-Pole Mounted)		Shunt Trip (Left-Pole Mounted)		UVR (Left-Pole Mounted)	
Configuration	Add This Suffix to Catalog No.	Configuration	Add This Suffix to Catalog No.	Voltage Range	Add This Suffix to Catalog No.	Voltage Range	Add This Suffix to Catalog No.

Series C G-Frame

1NO / 1NC 2NO / 2NC	A3 A6	1 Make / 1 Break	B3	24V ac 120V ac 240V ac 12V dc 24V dc 120V ac (GMCP) 240V ac (GMCP)	S7 S1 S2 S3 S4 S5 S6	24V ac 50/60 Hz 48V ac 50/60 Hz 60V ac 50/60 Hz 120V ac 50/60 Hz 240V ac 50/60 Hz 220V ac 50 Hz 440V ac 50 Hz 480V ac 60 Hz	T2 T3 T4 T1 T8 T7 T11 T12
If both an auxiliary switch and bell alarm are required, add B13 to the catalog number (right-pole mounted). Auxiliary switch and bell alarm are 240V rated.				(Not available for GMCP)			

Series C F-Frame

1NO / 1NC 2NO / 2NC	A06 A13	1 Make / 1 Break	B06	12 – 24V ac/dc 48 – 127V ac or 48 – 60V dc 208 – 380V ac 110 – 127V dc 415 – 600V ac or 220 – 250V dc	S02 S06 S10 S14	12V ac 24V ac 48V ac/dc 110 – 127V ac 208 – 240V ac 380 – 480V ac 525 – 600V ac 12V dc 24V dc 125V dc 220 – 250V dc	U02 U06 U38 U14 U18 U22 U26 U30 U34 U42 U46
If both an auxiliary switch and bell alarm are required, add C05 to the catalog number (right-pole mounted). Auxiliary switch and bell alarm are 600V rated.							

Series C J-Frame



1NO / 1NC 2 NO / 2NC	A06 A13	1 Make / 1 Break	B06	12 – 24V ac/dc 48 – 60V ac/dc 110 – 240V ac or 110 – 125V dc 380 – 440V ac/or 220 – 250V dc 480 – 600V ac	S42 S50 S10 S14 S18	12V ac 24V ac 48 – 60V ac 110 – 127V ac 208 – 240V ac 380 – 480V ac 12V dc 24V dc 48 – 60V dc 110 – 125V dc 220 – 250V dc	U06 U10 U14 U18 U22 U26 T02 T06 T10 T14 T18
If both an auxiliary switch and bell alarm are required, add C05 to the catalog number (right-pole mounted). Auxiliary switch and bell alarm are 600V rated.							

Series C K-Frame

1NO / 1NC 2NO / 2NC	A06 A13	1 Make / 1 Break	B06	12 – 24V ac/dc 48 – 60V ac/dc 110 – 240V ac or 110 – 125V dc 380 – 440V ac/or 220 – 250V dc 480 – 600V ac	S42 S50 S10 S14 S18	12V ac 24V ac 48 – 60V ac 110 – 127V ac 208 – 240V ac 380 – 480V ac 12V dc 24V dc 48 – 60V dc 110 – 125V dc 220 – 250V dc	U06 U10 U14 U18 U22 U26 T02 T06 T10 T14 T18
If both an auxiliary switch and bell alarm are required, add C05 to the catalog number (right-pole mounted). Auxiliary switch and bell alarm are 600V rated.							

Universal Molded Case Circuit Breakers — Accessories

Handle Mechanisms

	
Variable Depth / Thru Door UL Recognized and IEC Versions	Flange Flex Shaft ①

Terminals and Termination Accessory Devices

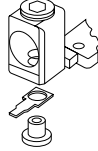
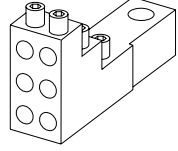
	
Terminals (Included with Breaker)	Multiwire

Series C G-Frame

Type 1 Version: Order HRGCV11L Type 3R, 4, 12 Version: Order HRGCV14L For GMCP Use: Type 1 Version: Order HRGMV11L Type 3R, 4, 12 Version: Order HRGMV14L (for 8-inch to 18-inch deep enclosure)	Type 1, 3R, 12 Versions: 3-Foot length; Order F0S03C 4-Foot length; Order F0S04C 5-Foot length; Order F0S05C 6-Foot length; Order F0S06C
--	---

Series C G-Frame

15 – 20 Ampere 14-2 AWG Cu/Al 2.5-4 mm ² Cu/Al 25 – 100 Ampere 10-1/0 AWG Cu/Al 4-50 mm ² Cu/Al (GMCP uses copper only terminals)	3-Hole Version: (3) 14-2 AWG Order 3TA100G3K 6-Hole Version: (6) 14-6 AWG Order 3TA100G6K
---	--

Series C F-Frame

Type 1, 3R, 12 Versions: For 6-inch and 10-inch deep enclosures, order HM1R06 . For 10-inch and 12-inch deep enclosures, order HM1R12 . For 16-inch and 18-inch deep enclosures, order HM1R16 . (add X to end for 4X version) (add W to beginning for IEC label on handle)	Type 1, 3R, 12 Versions: 3-Foot length; Order F1S03C 4-Foot length; Order F1S04C 5-Foot length; Order F1S05C 6-Foot length; Order F1S06C 7-Foot length; Order F1S07C 8-Foot length; Order F1S08C 9-Foot length; Order F1S09C 10-Foot length; Order F1S10C
---	--

Series C F-Frame

10 – 20 Ampere 14-10 AWG Cu/Al 2.5-4 mm ² Cu/Al 25 – 100 Ampere 14-1/0 AWG Cu/Al 2.5-50 mm ² Cu/Al 110 – 225 Ampere 4-4/0 AWG Cu/Al 25-95 mm ² Cu/Al (HMCP uses copper only terminals)	3-Hole Version: (3) 14-2 AWG Order 3TA150F3K 6-Hole Version: (6) 14-6 AWG Order 3TA150F6K
---	--

Series C J-Frame

Type 1, 3R, 12 Versions: For 6-inch and 10-inch deep enclosures, order HM2R06 . For 12-inch and 16-inch deep enclosures, order HM2R12 . For 18-inch and 20-inch deep enclosures, order HM2R16 . (add X to end for 4X version) (add W to beginning for IEC label on handle)	Type 1, 3R, 12 Versions: 3-Foot length; Order F2S03C 4-Foot length; Order F2S04C 5-Foot length; Order F2S05C 6-Foot length; Order F2S06C 7-Foot length; Order F2S07C 8-Foot length; Order F2S08C 9-Foot length; Order F2S09C 10-Foot length; Order F2S10C
---	--

Series C J-Frame

70 – 250 Ampere 4-350 MCM AWG Cu/Al 25-150 mm ² Cu/Al (HMCP uses copper only terminals)	3-Hole Version: (3) 14-2 AWG Order 3TA250J3K 6-Hole Version: (6) 14-6 AWG Order 3TA250J6K
--	--

Series C K-Frame

Type 1, 3R, 12 Versions: For 6-inch and 10-inch deep enclosures, order HM3R06 . For 12-inch and 16-inch deep enclosures, order HM3R12 . For 18-inch and 20-inch deep enclosures, order HM3R16 . (add X to end for 4X version) (add W to beginning for IEC label on handle)	Type 1, 3R, 12 Versions: 3-Foot length; Order F3S03C 4-Foot length; Order F3S04C 5-Foot length; Order F3S05C 6-Foot length; Order F3S06C 7-Foot length; Order F3S07C 8-Foot length; Order F3S08C 9-Foot length; Order F3S09C 10-Foot length; Order F3S10C
---	--

Series C K-Frame

300 – 350 Ampere 250-500 MCM AWG Cu/Al 120-240 mm ² Cu/Al 400 Ampere 3/0-200 (2) AWG Cu/Al 95-120 mm ² Cu/Al (HMCP uses copper only terminals)	3-Hole Version: (3) 12-2/0 AWG Order 3TA400K3K 6-Hole Version: (6) 14-2/0 AWG Order 3TA400K6K
--	--

① Type 4/4X handle mechanisms are available. Add Suffix X to complete catalog number. Add Suffix I to complete catalog number for IEC handle. Original narrow handle design (No C Suffix) is available.

Circuit & Motor Protection

Circuit Breakers

CATALOG SELECTION

Series G® Molded Case Circuit Breakers — EG-Frame — Catalog Numbering System

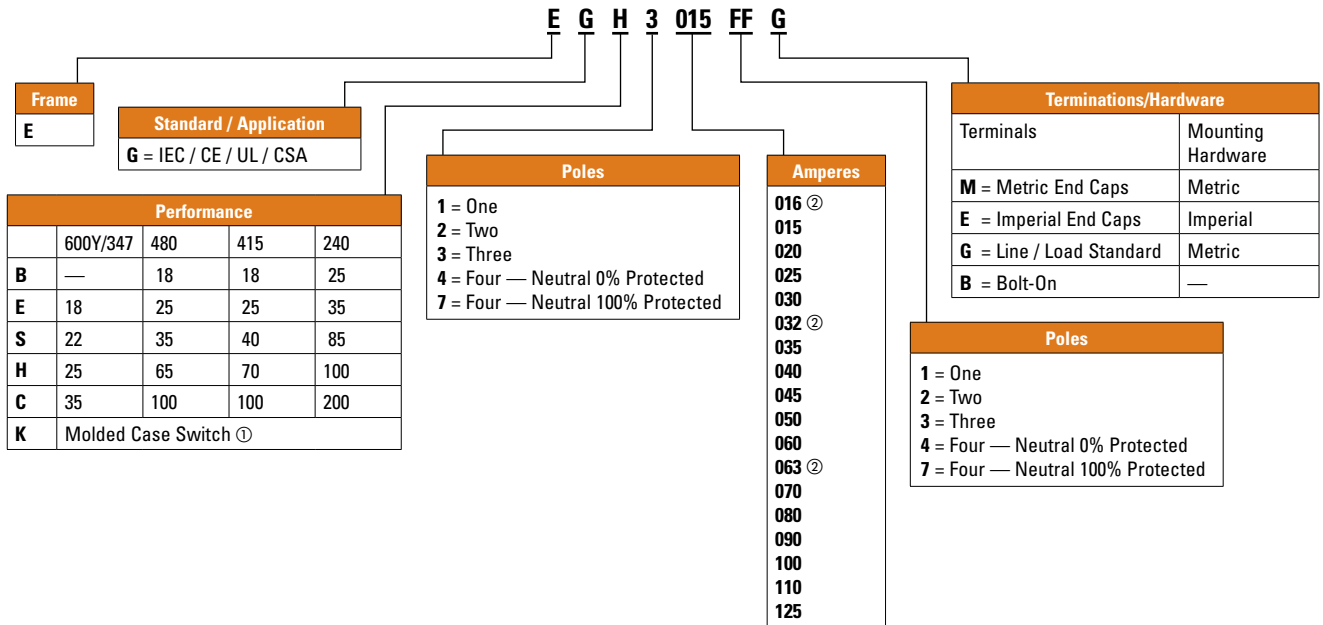

① Available only in 125 and 160A sizes.

② Is not UL rated.

Series G Molded Case Circuit Breakers — JG-Frame — Catalog Numbering System

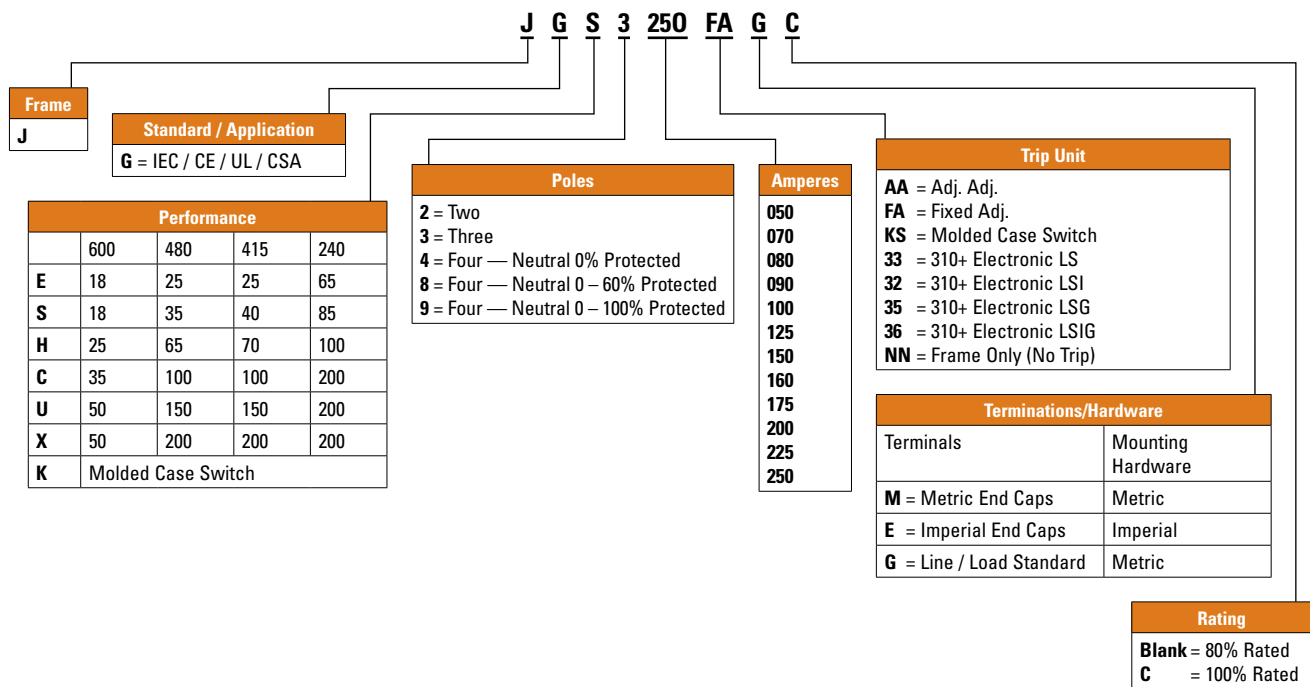

Circuit & Motor Protection

Circuit Breakers CATALOG SELECTION

Series G Molded Case Circuit Breakers — LG-Frame — Catalog Numbering System

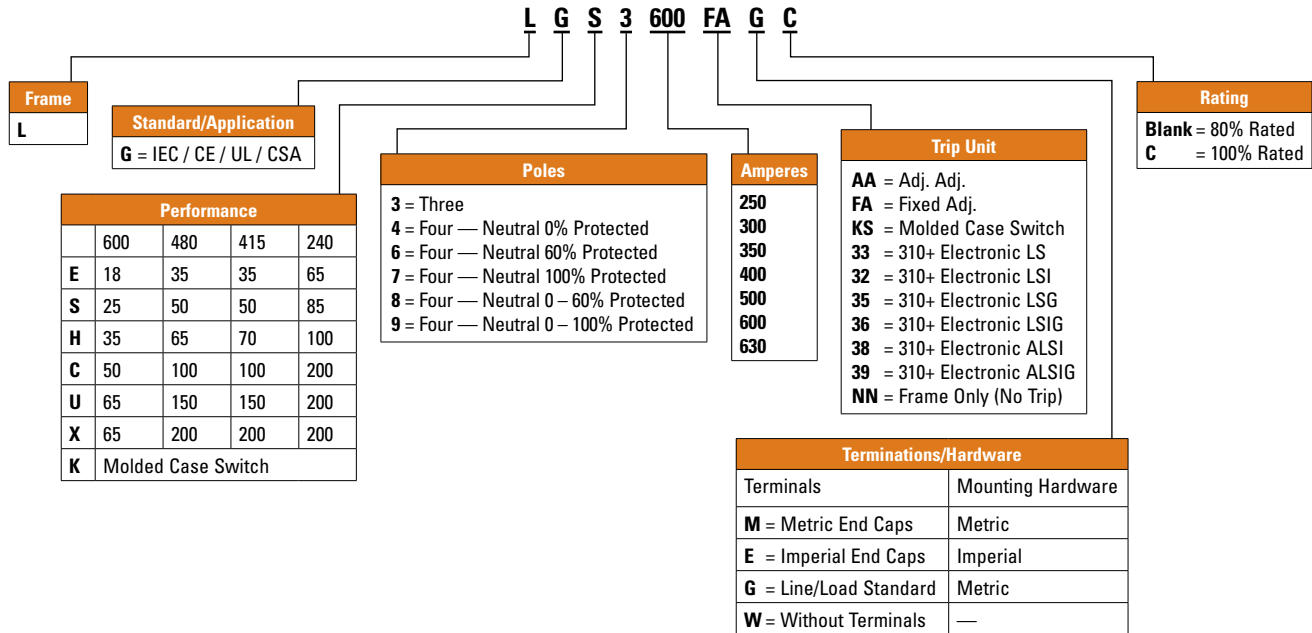

Circuit & Motor Protection

Circuit Breakers

PRODUCT SELECTION

Series G Molded Case Circuit Breakers

- Field-fit accessories
- Common accessories through 630A
- Space-saving footprint
- High-performance rating up to 200 kAIC at 480V
- Global ready: UL, CSA, CE, IEC, KEMA-KEUR listings



EG-Frame

Max. Cont. Amps at 40°C ①	3-Pole
	Fixed Thermal Fixed Magnetic

IC Rating: 25 kAIC at 415 and 480V ac

15	EGE3015FFG
16	EGE3016FFG
20	EGE3020FFG
25	EGE3025FFG
30	EGE3030FFG
32	EGE3032FFG
35	EGE3035FFG
40	EGE3040FFG
45	EGE3045FFG

50	EGE3050FFG
60	EGE3060FFG
63	EGE3063FFG
70	EGE3070FFG
80	EGE3080FFG
90	EGE3090FFG
100	EGE3100FFG
125	EGE3125FFG

IC Rating: 70 kAIC at 415V ac, 65 kAIC at 480V ac

15	EGH3015FFG
16	EGH3016FFG
20	EGH3020FFG
25	EGH3025FFG
30	EGH3030FFG
32	EGH3032FFG
35	EGH3035FFG
40	EGH3040FFG
45	EGH3045FFG

50	EGH3050FFG
60	EGH3060FFG
63	EGH3063FFG
70	EGH3070FFG
80	EGH3080FFG
90	EGH3090FFG
100	EGH3100FFG
125	EGH3125FFG

① 16, 32, 63A are not UL listed ratings.

Note: Complete breaker includes frame, trip unit, standard terminals and mounting hardware.

JG-Frame

Maximum Continuous Amperes	Magnetic Range	3-Pole
		Fixed Thermal Adjustable Magnetic

IC Rating: 25 kAIC at 415 and 480V ac

70	350 – 700	JGE3070FAG
90	450 – 900	JGE3090FAG
100	500 – 1000	JGE3100FAG
125	625 – 1250	JGE3125FAG
150	750 – 1550	JGE3150FAG
175	875 – 1750	JGE3175FAG
200	1000 – 2000	JGE3200FAG
225	1125 – 2250	JGE3225FAG
250	1250 – 2500	JGE3250FAG

IC Rating: 70 kAIC at 415V ac, 65 kAIC at 480V ac

70	350 – 700	JGH3070FAG
90	450 – 900	JGH3090FAG
100	500 – 1000	JGH3100FAG
125	625 – 1250	JGH3125FAG
150	750 – 1550	JGH3150FAG
175	875 – 1750	JGH3175FAG
200	1000 – 2000	JGH3200FAG
225	1125 – 2250	JGH3225FAG
250	1250 – 2500	JGH3250FAG

LG Frame ①

Ampere Rating	3-Pole ②
	Fixed Thermal Adj. Magnetic

IC Rating: 35 kAIC at 415 and 480V ac

250	LGE3250FAG
300	LGE3300FAG
350	LGE3350FAG
400	LGE3400FAG
500	LGE3500FAG
600	LGE3600FAG

IC Rating: 70 kAIC at 415V ac, 65 kAIC at 480V ac

250	LGH3250FAG
300	LGH3300FAG
350	LGH3350FAG
400	LGH3400FAG
500	LGH3500FAG
600	LGH3600FAG

① Replace suffix "G" with "W" for no line or load terminals.

② For 2-pole applications, use two outer poles.

Series G Molded Case Circuit Breakers

EG-Frame — 480V ac, 600Y / 347V ac Maximum

Continuous Amperes	Cam Setting	Motor Full Load Current Amperes ①	MCP Trip Setting ②	MCP Catalog Number
3	A	.69 – .91	9	HMCPE003A0C
	B	1.1 – 1.3	15	
	C	1.6 – 1.7	21	
	D	2.0 – 2.2	27	
	E	2.3 – 2.5	30	
	F	2.6 – 2.8	33	
7	A	1.5 – 2.0	21	HMCPE007C0C
	B	2.6 – 3.1	35	
	C	3.7 – 3.9	49	
	D	4.8 – 5.2	63	
	E	5.3 – 5.7	70	
	F	5.8 – 6.1	77	
15	A	3.4 – 4.5	45	HMCPE015E0C
	B	5.7 – 6.8	75	
	C	8.0 – 9.1	105	
	D	10.4 – 11.4	135	
	E	11.5 – 12.6	150	
	F	12.7 – 13.0	165	
30	A	3.9 – 9.1	90	HMCPE030H1C
	B	11.5 – 13.7	150	
	C	16.1 – 18.3	210	
	D	20.7 – 22.9	270	
	E	23.0 – 25.2	300	
	F	25.3 – 26.1	330	
50	A	11.5 – 15.2	150	HMCPE050K2C
	B	19.2 – 22.9	250	
	C	26.9 – 30.6	350	
	D	34.6 – 38.3	450	
	E	38.4 – 42.1	500	
	F	42.2 – 43.5	550	
70	A	16.1 – 30.6	210	HMCPE070M2C
	B	26.9 – 32.2	350	
	C	37.6 – 42.9	490	
	D	48.4 – 53.7	630	
	E	53.8 – 59.1	700	
	F	59.2 – 60.9	770	
100	A	23.0 – 30.6	300	HMCPE100R3C
	B	38.4 – 46.0	500	
	C	53.8 – 61.4	700	
	D	69.2 – 76.8	900	
	E	76.9 – 84.5	1000	
	F	84.6 – 87.0	1100	
100	A	38.4 – 46.0	500	HMCPE100T3C
	B	57.6 – 65.2	750	
	C	76.9 – 84.5	1000	
	D	③	1250	
	E	③	1375	
	F	③	1500	

① Motor FLA ranges are typical. The corresponding trip setting is at 13 times the minimum FLA value shown. Where a 13 times setting is required for an intermediate FLA value, alternate cam settings and/or MCP ratings should be used.

② For dc applications, actual trip levels are approximately 40% higher than values shown.

③ Settings above 10 x In are for special applications. Where the ampere rating of the disconnecting means cannot be less than 115% of the motor full load ampere rating.

JG-Frame — 600V ac Maximum, 250V dc Maximum

Continuous Amperes	MCP Trip Range Amperes	MCP Catalog Number
250	500 – 1000 625 – 1250 750 – 1500	HMCJP250D5L HMCJP250F5L HMCJP250G5L
	875 – 1750 1000 – 2000 1125 – 2250 1250 – 2500	HMCJP250J5L HMCJP250K5L HMCJP250L5L HMCJP250W5L

LG-Frame — 600V ac Maximum, 250V dc Maximum ①

Continuous Amperes	MCP Trip Range Amperes	MCP Catalog Number
600	1250 – 2500 1500 – 3000 1750 – 3500	HMCPL600L6G HMCPL600N6G HMCPL600R6G
	2000 – 4000 2250 – 4500 2500 – 5000 3000 – 6000	HMCPL600X6G HMCPL600Y6G HMCPL600P6G HMCPL600M6G

① Equipped with an electromechanical trip device.

Circuit & Motor Protection

Circuit Breakers

PRODUCT SELECTION

Series G Molded Case Circuit Breakers — Accessories

Field Fit Kit Catalog Numbers

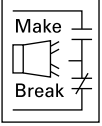
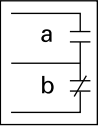
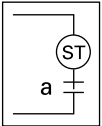
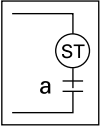
Description		Pole Location	Frame — EG, JG & LG
Alarm Lockout 	Make / Break	Right	ALM1M1BEPK ①
	2 Make / 2 Break	Right	ALM2M2BEPK ②
Auxiliary Switch 	1A, 1B	Right	AUX1A1BPK
	2A, 2B	Right	AUX2A2BPK
Auxiliary Switch / Alarm Lockout		Right	AUXALRMEPK ③
Shunt Trip — Standard 	120V ac	Left	SNT120CPK ④
	240V ac	Left	SNT120CPK ④
	12V dc	Left	SNT012CPK
	24V dc	Left	SNT060CPK
	48V dc	Left	SNT060CPK
	380 – 600V ac	Left	SNT480CPK ⑤
Undervoltage Release Mechanism 	110 – 127V ac	Left	UVR120APK
	208 – 240V ac	Left	UVR240APK
	24V dc, ac	Left	UVR024CPK
	48 – 60V dc	Left	UVR048DPK
	12V dc, ac	Left	UVR012CPK
	48 – 60V ac	Left	UVR048APK
	120V dc	Left	UVR125DPK
	220 – 250V dc	Left	UVR250DPK
	380 – 500V ac	Left	UVR480APK
	525 – 600V ac	Left	UVR600APK

① Part number for JG and LG is ALM1M1BJPK.

② Part number for JG and LG is ALM2M2BJPK.

③ Part number for JG and LG is AUXALRMJPK.

④ 110 – 125V dc, 50/60 Hz.

⑤ 380 – 600V dc, 50/60 Hz.

Multewire Connectors Ordering Information (Package of 3)

Max. Amps	Wires per Terminal	Wire Size Range AWG Cu	Frame	Kit Catalog Number
125	3	14 – 2	EG	3TA125E3K
125	6	14 – 6	EG	3TA125E6K
250	3	14 – 2	JG	3TA250FJ3
250	6	14 – 6	JG	3TA250FJ6



Terminal Shields

Location	Number of Poles	Frame	IP30 Protection
			Catalog Numbers
Line	3	EG	EFTS3K
Line	4	EG	EFTS4K
Line or Load	2, 3	JG	FJTS3K
Line or Load	4	JG	FJTS4K

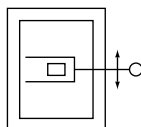

Interphase Barriers

Package of 2		
Number of Poles	Frame	Catalog Number
3 or 4	EG	EIPBK
3	JG	FJIPBK
4	JG	FJIPBK4
3 or 4	LG	IPB3

Flex Shaft Handle Mechanisms

	Breaker Frame	Flexible Shaft Length in Feet (m)	
		4 (1.2)	7 (2.1)
		Catalog Number	Catalog Number
 	EG	EHMFS04	EHMFS07
	JG	JHMFS04	JHMFS07
	LG	LHMFS04	LHMFS07

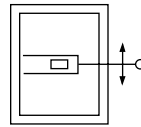
Universal Rotary Handle Mechanism

	Shaft Length in Inches (mm)	Handle Color	NEMA Rating	Complete Catalog Number
	EG-Frame			
	12.00 (304.8) 12.00 (304.8)	Black Black	1, 12 4, 4X, 3R	EHMVD12B EHMVD12BX
	JG-Frame			
	12.00 (304.8) 12.00 (304.8)	Black Black	1, 12 4, 4X, 3R	FJHMVD12B FJHMVD12BX
	LG-Frame			
	12.00 (304.8) 12.00 (304.8)	Black Black	1, 12 4, 4X, 3R	KLHMVD12B KLHMVD12BX

Series G Molded Case Circuit Breakers — Accessories

External Accessories

Description	Fit Type	Frame		
		EG	JG	LG
Non-Padlockable Handle Block	Field	EFHB	—	—
Padlockable Handle Block	Field	EFPHB	—	—
Padlockable Handle Block Off-Only	Field	EFPHBOFF	FJPHBOFF	LBHPOFF
Padlockable Handle Lock Hasp	Field	EFPHL	FJPHL	LPHL
Padlockable Handle Lock Hasp Off-Only	Field	EFPHLOFF	FJPHLOFF	LPHLOFF
Kirk Key Interlock Kit ①②	Field	—	KYKJG	KYKLG
Castell Key Interlock Kit ②③	Field	—	CTKJG	CTKLG
Slide Bar Interlock ④	Field	EF SBI	FJ SBI	LG SBI
Walking Beam Interlock	3-Pole	EG3WBI	JG3WBI	LG3WBI
	4-Pole	EG4WBI	JG4WBI	LG4WBI
Electrical Operator	120/240V ac	MOPEG240C	MOPJG240C	MOPLG240C
	125V dc	MOPEG240C	MOPJG240C	MOPLG240C
Plug-In Adapters	3-Pole	PAD3E	PAD3J	PAD3L
	4-Pole	PAD4E	PAD4J	PAD4L
Rear Connecting Studs	Field	EFRCSDL	FJRCSDL	3P-LRCS3WK
		EFRCSDS	FJRCSDS	4P-LRCS4WK
		EFRCSWL	FJRCSWL	—
		EFRCSWS	FJRCSWS	—

① Provision only.

② See Tab 12 of the Distribution Products Catalog, CA08101001E, for bolt projection dimensions.

③ Castell bolt mounting hole must be 10 mm.

④ Requires two breakers.

Circuit & Motor Protection

Circuit Breakers

CATALOG SELECTION / PRODUCT SELECTION

Type QC Miniature Circuit Breakers — Cable-In / Cable-Out Type QC — Catalog Numbering System

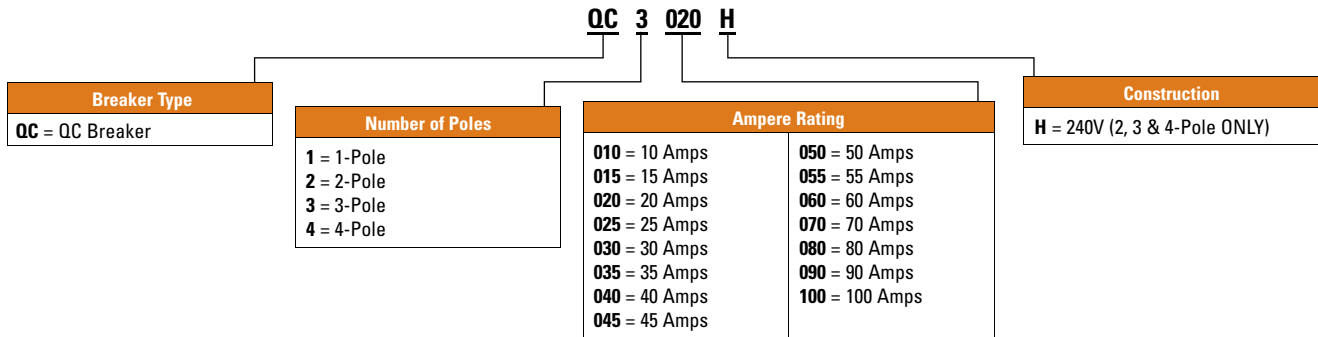

Type QC Miniature Circuit Breakers — Cable-In / Cable-Out Type QC

For Cable-In / Cable-Out Panel Mount Applications

- 1 – 4-pole options
- Built and listed to UL 489
- All products UL and CSA listed
- All products 10 – 100A are HACR rated



QUICKLAG Type QC 10,000 Ampere I.C. Thermal-Magnetic Breakers

Continuous Ampere Rating at 40°C	1-Pole	2-Pole	3-Pole
	120/240V ac	120/240V ac	240V ac
	Catalog Number	Catalog Number	Catalog Number
10	QC1010	QC2010	—
15	QC1015 ① ②	QC2015	QC3015H
20	QC1020 ① ②	QC2020	QC3020H
30	QC1030	QC2030	QC3030H
40	QC1040	QC2040	QC3040H
50	QC1050	QC2050	QC3050H
60	—	QC2060	QC3060H
70	—	QC2070	QC3070H
100	QC1100	QC2100	QC3100H

① Switching duty rated for 120V ac fluorescent light applications only.

② For special low-magnetic breaker, order QC1015L1 or QC1020L1.

Note: For non-automatic switches, see Distribution Products Catalog, CA08101001E, Tab 11.

Type QC Miniature Circuit Breakers — Cable-In / Cable-Out Type QCD — Catalog Numbering System

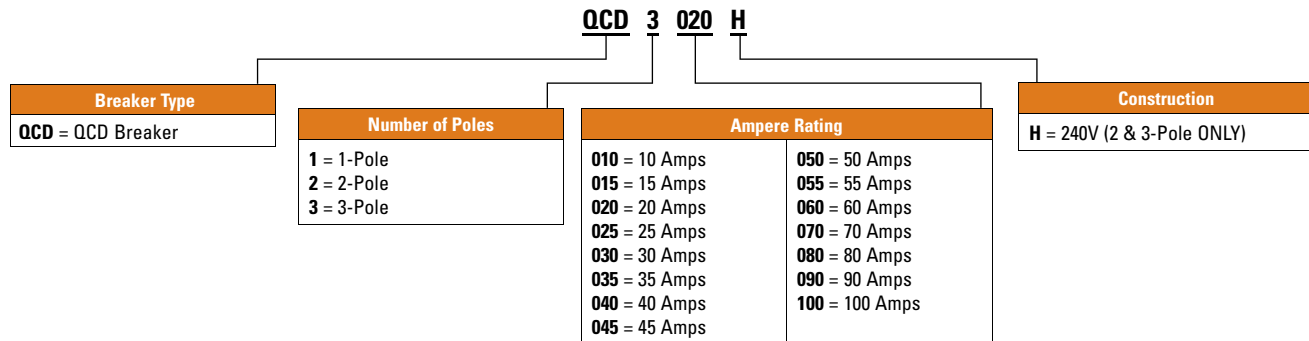

Type QC Miniature Circuit Breakers — Cable-In / Cable-Out Type QCD

For Cable-In / Cable-Out DIN-Rail Mount HVAC Applications

- 1 – 3-pole options
- Modular construction
- DIN mounted (symmetrical rail 35 x 7.5 DIN / EN 50 022)
- Flexible power feed connection: wire size, position
- Same breaker size for entire rating range
- Field-mountable accessories: finger-shroud proof, quick connect terminals, jumper units



QUICKLAG Type QCD 10,000 Ampere I.C. Thermal-Magnetic Breakers

Continuous Ampere Rating at 40°C	1-Pole	2-Pole	3-Pole
	120/240V ac	120/240V ac	240V ac
	Catalog Number	Catalog Number	Catalog Number
10	QCD1010	QCD2010	—
15	QCD1015	QCD2015	QCD3015H
20	QCD1020	QCD2020	QCD3020H
30	QCD1030	QCD2030	QCD3030H
40	QCD1040	QCD2040	QCD3040H
50	QCD1050	QCD2050	QCD3050H
60	QCD1060	QCD2060	QCD3060H
70	—	QCD2070	QCD3070H
100	—	QCD2100	QCD3100H

Circuit & Motor Protection

Circuit Breakers

CATALOG SELECTION / PRODUCT SELECTION

Type QC Miniature Circuit Breakers — Cable-In / Cable-Out 1/2-Inch Wide Types QCR, QCF — Catalog Numbering System

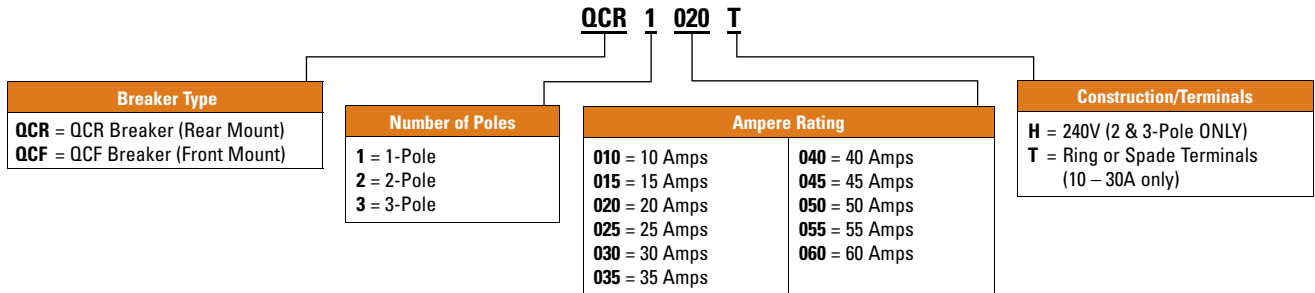

Type QC Miniature Circuit Breakers — Cable-In / Cable-Out 1/2-Inch Wide Types QCR, QCF

When Space is at a Premium

- QCR: For DIN-Rail mount cable-in / cable-out applications
- QCF: For front-mount through-the-door cable-in / cable-out applications
- 1/2-inch (12.7 mm) wide per pole
- Three-position handle: ON, Tripped (center), OFF
- Thermal-magnetic protection
- 1, 2 and 3-pole
- 10 kAIC at 120/240V ac, 10 – 60A
- 10 kAIC at 240V ac, 10 – 30A



QUICKLAG Type QCR Breaker 10 kAIC Interrupting Ratings ①②③④

Continuous Ampere Rating at 40°C	1-Pole	2-Pole	3-Pole
	120/240V ac	120/240V ac	240V ac
	Catalog Number	Catalog Number	Catalog Number
10	QCR1010 QCR1010T	QCR2010 QCR2010T	— —
15	QCR1015 ⑤ QCR1015T ⑤	QCR2015 QCR2015T	QCR3015H QCR3015HT
20	QCR1020 ⑤ QCR1020T ⑤	QCR2020 QCR2020T	QCR3020H QCR3020HT
25	QCR1025 —	QCR2025 —	QCR3025H QCR3025HT
30	QCR1030 —	QCR2030 —	QCR3030H QCR3030HT
35	QCR1035	QCR2035	—
40	QCR1040	QCR2040	—
45	QCR1045	QCR2045	—
50	QCR1050	QCR2050	—
55	QCR1055	—	—
60 ⑥	QCR1060	QCR2060	—

- ① Standard breaker terminals are box type lugs.
- ② Breakers with "T" catalog number suffix are suitable for line and load side ring terminal connection (#10 – 32 plus/minus terminal screw provided).
- ③ Breakers with "P" catalog number suffix are suitable for terminating two 10 AWG Quick-Connect Type Terminals per phase on breaker load side.
- ④ Breakers with shunt trip (extra pole required on breaker right-hand side) are available on 1, 2 and 3-pole.
- ⑤ All 15 and 20 ampere single-pole breakers are SWD (switching duty) rated for fluorescent lighting applications.
- ⑥ 60/75°C Cu/Al wire on all ratings except 60 amperes, which requires Cu only conductor.

Type QC Miniature Circuit Breakers — Cable-In / Cable-Out 1/2-Inch Wide, Types QCR, QCF

QUICKLAG Type QCF Breaker 10 kAIC Interrupting Ratings ①②③

Continuous Ampere Rating at 40°C	1-Pole	2-Pole	3-Pole
	120/240V ac	120/240V ac	240V ac
	Catalog Number	Catalog Number	Catalog Number
10	QCF1010 QCF1010T	QCF2010 QCF2010T	— —
15	QCF1015 ④ —	QCF2015 —	QCF3015H QCF3015HT
20	QCF1020 ④ —	QCF2020 —	QCF3020H QCF3020HT
25	QCF1025 —	QCF2025 —	QCF3025H QCF3025HT
30	QCF1030 —	QCF2030 —	QCF3030H QCF3030HT
40	QCF1040	QCF2040	—
50	QCF1050	QCF2050	—
60 ⑤	QCF1060	QCF2060	—

① Standard breaker terminals are box type lugs.



② Breakers with "T" catalog number suffix are suitable for line and load side ring terminal connection (#10 – 32 plus/minus terminal screw provided).

③ Breakers with shunt trip attachment (extra pole required on breaker right-hand side) are available.

④ All 15 and 20 ampere single-pole breakers are SWD (switching duty) rated for fluorescent lighting applications.

⑤ 60/75°C Cu/Al wire on all ratings except 60 amperes, which requires Cu only conductor.

Accessories

	Description	Catalog Number
	Steel mounting clip mounts QCR breaker if individual mounting is required. Quantity two required for 1- and 2-pole and four required for 3-pole breakers.	QCRMTGFT
	Removable padlock device for single-pole QCR or QCF breaker.	QCRFPL1P
	Removable padlock device for multi-pole QCR or QCF breaker.	QCRFPLMP
	Padlock bracket assembly for QCR or QCF single- or multi-pole breakers (OFF only).	QCRFLOFF
	Padlock bracket for QCR, lock-off only.	QCRPLOFF
	QUICKLAG Type C Spacer	QCRSPACER
	QCR and QCF Ring or Spade Lug Terminals (10 – 30A ratings only) Factory installed line and load side terminals each equipped with a #10-32 screw suitable for terminating one 10 AWG wire with insulated ring or spade type terminal as shown.	Suffix "T"

Circuit & Motor Protection

Circuit Breakers

CATALOG SELECTION / PRODUCT SELECTION

Type QC Miniature Circuit Breakers — Cable-In / Cable-Out Ground Fault and Equipment Protector Types QCGF, QCGFEP — Catalog Numbering System

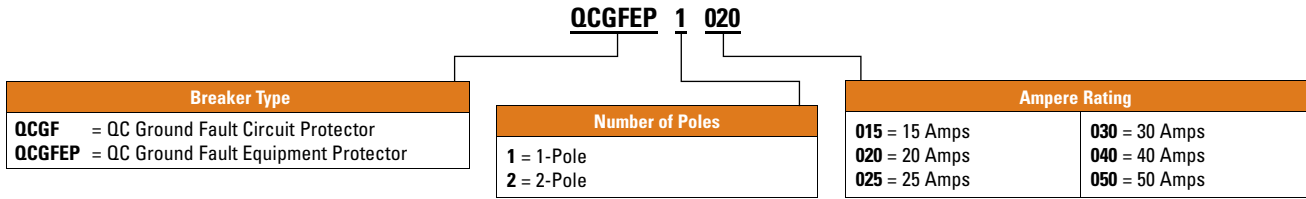

Type QC Miniature Circuit Breakers — Cable-In / Cable-Out 1/2-Inch Wide Types QCGF, QCGFEP

For Cable-In / Cable-Out Panel-Mount Applications

- QUICKLAG ground fault circuit breakers, Class A GFCI:
 - Built and tested to UL 943
 - 5 mA trip sensitivity
- QUICKLAG ground fault equipment protectors:
 - Built and tested to UL 1053
 - 30 mA trip sensitivity
- All products UL and CSA listed



Types QCGF and QCGFEP Thermal-Magnetic Breakers

Continuous Ampere Rating at 40°C	1-Pole	2-Pole
	120/240V ac	120/240V ac
	Catalog Number	Catalog Number

Ground Fault Circuit Breakers — 5 mA Sensitivity QUICKLAG Type: QCGF 10,000 Ampere I.C.

15	QCGF1015	QCGF2015
20	QCGF1020	QCGF2020
30	QCGF1030	QCGF2030
40	QCGF1040	QCGF2040
50	—	QCGF2050

Ground Fault Equipment Protectors — 30 mA Sensitivity QUICKLAG Type: QCGFEP 10,000 Ampere I.C.

15	QCGFEP1015	QCGFEP2015
20	QCGFEP1020	QCGFEP2020
30	QCGFEP1030	QCGFEP2030
40	QCGFEP1040	QCGFEP2040
50	—	QCGFEP2050

Type QC Miniature Circuit Breakers

Accessories

	Accessory ①	Description	Catalog Number
 <p>QL1NPL QL23NPL</p>	Handle Locks: Non-Padlockable ②	QUICKLAG Type P, B, C — 1-Pole QUICKLAG Type P, B, C — 2, 3-Pole	QL1NPL QL23NPL
 <p>QL1PL QC123PL</p>	Handle Locks: Padlockable	QUICKLAG Type P, B, C — 1-Pole QUICKLAG Type C — 1, 2, 3-Pole QUICKLAG Type C — 1, 2, 3-Pole (off only)	QL1PL QC123PL QCD123PLOFF
 <p>QL1HT</p>	Handle Tie	QUICKLAG Handle Tie — 1-Pole QUICKLAG Handle Tie — 3-Pole	QL1HT QL3HT
 <p>QCFCLIP QC1FP</p> <p>QC2FP QC3FP</p> <p>QCBCLIP</p>	Mounting Hardware	QUICKLAG Type C Face Mounting Clip QUICKLAG Type C Face Mounting Plate — 1-Pole QUICKLAG Type C Face Mounting Plate — 2-Pole QUICKLAG Type C Face Mounting Plate — 3-Pole QUICKLAG Type C Face Mounting Plate and Lock-off (off only) — 2-Pole ③ QUICKLAG Type C Face Mounting Plate and Lock-off (off only) — 3-Pole QUICKLAG Type C Base Mounting Clamp	QCFCLIP QC1FP QC2FP QC3FP QC2FPLOFF QC3FPLOFF QCBCLIP

① See Page 21 for QCR and QCF accessories.

② Can lock in ON or OFF position.

③ Suitable for ground fault breakers.





Circuit & Motor Protection

Circuit Breakers

PRODUCT SELECTION

Type QC Miniature Circuit Breakers

Accessories (Continued)

	Accessory ①	Description	Catalog Number
 <p>QC6BP</p>	Mounting Hardware	QUICKLAG Base Mounting Plate — 6 Poles Total QUICKLAG Type C Base Mounting Plate — 6 Poles Total — Heavy-Duty Screw-Secured QUICKLAG Type C (QCD) 2-Way Jumper Unit with Cover QUICKLAG Type C (QCD) 4-Way Jumper Unit with Cover QUICKLAG Type C (QCD) 6-Way Jumper Unit with Cover QUICKLAG Type C (QCD) 2-Way Jumper Unit, no Cover QUICKLAG Type C (QCD) 4-Way Jumper Unit, no Cover QUICKLAG Type C (QCD) 6-Way Jumper Unit, no Cover QUICKLAG Type QCD Finger Protection Attachment QUICKLAG Type C DIN-Rail Adapter	QC6BP QC6BPS
 <p>QCDJ4</p>			QCDJ2 QCDJ4 QCDJ6 QCDJ2T QCDJ4T QCDJ6T QCDFP QCDINADAPT
 <p>QCDINADAPT</p>			
 <p>QCDFP</p>			

① See Page 21 for QCR and QCF accessories.

WMZT UL 489 Miniature Circuit Breakers — Catalog Numbering System

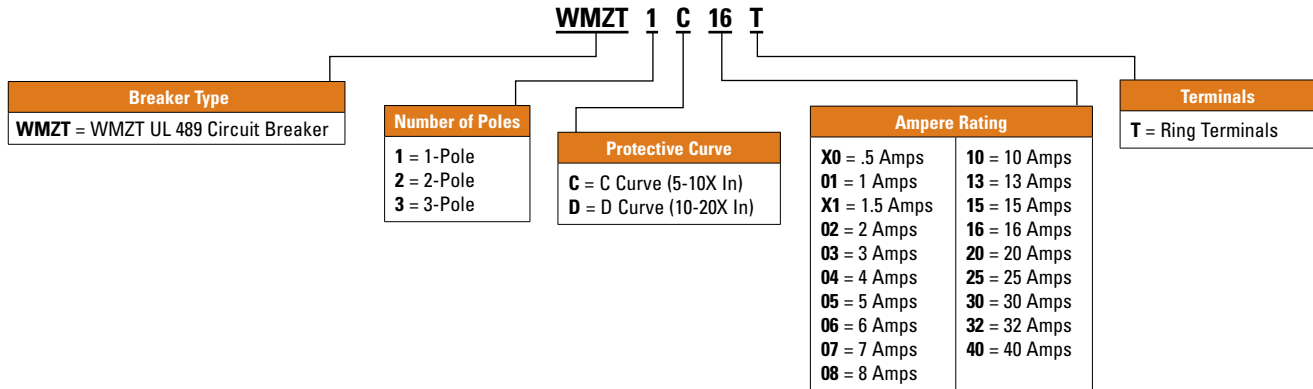

WMZT UL 489 Miniature Circuit Breakers

- UL 489 listed DIN-Rail mounted miniature circuit breakers up to 40 ampere current rating
- Current limiting design provides fast short circuit interruption that reduces let-through energy
- Thermal-magnetic overcurrent protection available with C and D curve level of protection
 - C Curve — 5 to 10X In — for medium inrush startup currents
 - D Curve — 10 to 20X In — provides a magnetic range to allow for high inrush levels
- Ring-tongue terminals available
- Complete line of accessories



WMZT UL 489 Circuit Breakers

Ampere Rating	C Curve (5 – 10X In Current Rating)			D Curve (10 – 20X In Current Rating)		
	1-Pole ①	2-Pole ①	3-Pole ①	1-Pole ①	2-Pole ①	3-Pole ①
	Catalog Number	Catalog Number	Catalog Number	Catalog Number	Catalog Number	Catalog Number
0.5	WMZT1CX0	WMZT2CX0	WMZT3CX0	WMZT1DX0	WMZT2DX0	WMZT3DX0
1	WMZT1C01	WMZT2C01	WMZT3C01	WMZT1D01	WMZT2D01	WMZT3D01
1.5	WMZT1CX1	WMZT2CX1	WMZT3CX1	WMZT1DX1	WMZT2DX1	WMZT3DX1
2	WMZT1C02	WMZT2C02	WMZT3C02	WMZT1D02	WMZT2D02	WMZT3D02
3	WMZT1C03	WMZT2C03	WMZT3C03	WMZT1D03	WMZT2D03	WMZT3D03
4	WMZT1C04	WMZT2C00	WMZT3C04	WMZT1D04	WMZT2D04	WMZT3D04
5	WMZT1C05	WMZT2C05	WMZT3C05	WMZT1D05	WMZT2D05	WMZT3D05
6	WMZT1C06	WMZT2C06	WMZT3C06	WMZT1D06	WMZT2D06	WMZT3D06
7	WMZT1C07	WMZT2C07	WMZT3C07	WMZT1D07	WMZT2D07	WMZT3D07
8	WMZT1C08	WMZT2C08	WMZT3C08	WMZT1D08	WMZT2D08	WMZT3D08
10	WMZT1C10	WMZT2C10	WMZT3C10	WMZT1D10	WMZT2D10	WMZT3D10
13	WMZT1C13	WMZT2C13	WMZT3C13	WMZT1D13	WMZT2D13	WMZT3D13
15	WMZT1C15	WMZT2C15	WMZT3C15	WMZT1D15	WMZT2D15	WMZT3D15
16	WMZT1C16	WMZT2C16	WMZT3C16	WMZT1D16	WMZT2D16	WMZT3D16
20	WMZT1C20	WMZT2C20	WMZT3C20	WMZT1D20	WMZT2D20	WMZT3D20
25	WMZT1C25	WMZT2C25	WMZT3C25	WMZT1D25	WMZT2D25	WMZT3D25
30	WMZT1C30	WMZT2C30	WMZT3C30	WMZT1D30	WMZT2D30	WMZT3D30
32	WMZT1C32	WMZT2C32	WMZT3C32	WMZT1D32	WMZT2D32	WMZT3D32
40	WMZT1C40	WMZT2C40	WMZT3C40	WMZT1D40	WMZT2D40	WMZT3D40

① For ring-tongue terminals, ADD Suffix "T" to above catalog number.

Circuit & Motor Protection

Circuit Breakers

CATALOG SELECTION / PRODUCT SELECTION

WMS UL 1077 Miniature Circuit Breakers — Supplementary Protectors — Catalog Numbering System

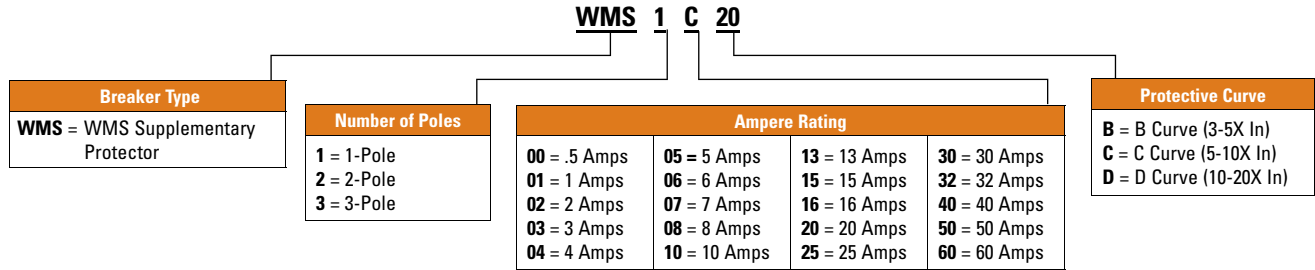

WMS UL 1077 Miniature Circuit Breakers — Supplementary Protectors

- UL 1077 recognized DIN-Rail mounted supplemental protectors up to 60A
- Current limiting design provides fast short circuit interruption that reduces let-through energy
- Thermal-magnetic overcurrent protection available with B, C and D curve levels of protection
 - B Curve — 3 to 5X In — for maximum protection of control circuit wiring from low-level short circuit faults
 - C Curve — 5 to 10X In — for medium inrush startup currents
 - D Curve — 10 to 20X In — provides a magnetic range to allow for high inrush levels
- Ideal replacement for fuses that are applied as supplemental protection
- Complete line of accessories



WMS UL 1077 Supplementary Protectors

Ampere Rating	B Curve (3 – 5X In Current Rating)			C Curve (5 – 10X In Current Rating)			D Curve (10 – 20X In Current Rating)		
	1-Pole	2-Pole	3-Pole	1-Pole	2-Pole	3-Pole	1-Pole	2-Pole	3-Pole
	Catalog Number	Catalog Number	Catalog Number	Catalog Number	Catalog Number	Catalog Number	Catalog Number	Catalog Number	Catalog Number
0.5	—	—	—	WMS1C00	WMS2C00	WMS3C00	WMS1D00	WMS2D00	WMS3D00
1	—	—	—	WMS1C01	WMS2C01	WMS3C01	WMS1D01	WMS2D01	WMS3D01
2	—	—	—	WMS1C02	WMS2C02	WMS3C02	WMS1D02	WMS2D02	WMS3D02
3	—	—	—	WMS1C03	WMS2C03	WMS3C03	WMS1D03	WMS2D03	WMS3D03
4	—	—	—	WMS1C04	WMS2C04	WMS3C04	WMS1D04	WMS2D04	WMS3D04
5	—	—	—	WMS1C05	WMS2C05	WMS3C05	WMS1D05	WMS2D05	WMS3D05
6	WMS1B06	WMS2B06	WMS3B06	WMS1C06	WMS2C06	WMS3C06	WMS1D06	WMS2D06	WMS3D06
7	WMS1B07	WMS2B07	WMS3B07	WMS1C07	WMS2C07	WMS3C07	WMS1D07	WMS2D07	WMS3D07
8	WMS1B08	WMS2B08	WMS3B08	WMS1C08	WMS2C08	WMS3C08	WMS1D08	WMS2D08	WMS3D08
10	WMS1B10	WMS2B10	WMS3B10	WMS1C10	WMS2C10	WMS3C10	WMS1D10	WMS2D10	WMS3D10
13	WMS1B13	WMS2B13	WMS3B13	WMS1C13	WMS2C13	WMS3C13	WMS1D13	WMS2D13	WMS3D13
15	WMS1B15	WMS2B15	WMS3B15	WMS1C15	WMS2C15	WMS3C15	WMS1D15	WMS2D15	WMS3D15
16	WMS1B16	WMS2B16	WMS3B16	WMS1C16	WMS2C16	WMS3C16	WMS1D16	WMS2D16	WMS3D16
20	WMS1B20	WMS2B20	WMS3B20	WMS1C20	WMS2C20	WMS3C20	WMS1D20	WMS2D20	WMS3D20
25	WMS1B25	WMS2B25	WMS3B25	WMS1C25	WMS2C25	WMS3C25	WMS1D25	WMS2D25	WMS3D25
30	WMS1B30	WMS2B30	WMS3B30	WMS1C30	WMS2C30	WMS3C30	WMS1D30	WMS2D30	WMS3D30
32	WMS1B32	WMS2B32	WMS3B32	WMS1C32	WMS2C32	WMS3C32	WMS1D32	WMS2D32	WMS3D32
40	WMS1B40	WMS2B40	WMS3B40	WMS1C40	WMS2C40	WMS3C40	WMS1D40	WMS2D40	WMS3D40
50	WMS1B50	WMS2B50	WMS3B50	WMS1C50	WMS2C50	WMS3C50	—	—	—
60	WMS1B60	WMS2B60	WMS3B60	WMS1C60	WMS2C60	WMS3C60	—	—	—

Miniature Circuit Breakers — Accessories

WMZT UL 489 Breakers

Accessory / Description	Catalog Number
2-Pole Contact or Auxiliary Contact/Trip Indicating Contact	WMZTAUXTRIP
Auxiliary Contact	WMZTAUX
Shunt Trip 110 – 415V ac Shunt Trip 12 – 110V ac	WMZTST415 WMZTST110
Padlock Hasp	WMZPLK
Bus Bar — 1-Pole 6 Terminals	WMZT1P6T
Bus Bar — 1-Pole 12 Terminals	WMZT1P12T
Bus Bar — 1-Pole 18 Terminals	WMZT1P18T
Bus Bar — 2-Pole 6 Terminals	WMZT2P6T
Bus Bar — 2-Pole 12 Terminals	WMZT2P12T
Bus Bar — 2-Pole 18 Terminals	WMZT2P18T
Bus Bar — 3-Pole 6 Terminals	WMZT3P6T
Bus Bar — 3-Pole 12 Terminals	WMZT3P12T
Bus Bar — 3-Pole 18 Terminals	WMZT3P18T
3-Pole Bus Bar Shroud	WMZT3PSHROUD
Extension Terminal — 35 mm (2 – 14 AWG)	WMZT35EXT
Bus Connector — Conductors up to 50 mm ² (~1/0 AWG)	WMZTBCON

WMS UL 1077 Supplementary Protectors

Accessory / Description	Module Width	Catalog Number
Auxiliary Switch		
Number of Contacts: 1A/1B	1/2	WAX1A1B
Alarm Switch		
Number of Contacts: 1A/1B	1/2	WAL1A1B
Shunt Trip		
Voltage: 110/220V ac	1	WST220A
240/415V ac	1	WST415A
12/48V dc	1	WST48D
Undervoltage Release		
Voltage: 240V ac	1	WUVR240A
48V dc	1	WUVR48D
24V dc	1	WUVR24D
ID Labels		
Identification Labels	—	WIDL
Padlock Accessories		
Padlocking Attachment Padlock Key	—	WPLK WPKEY
Lockoff		
Lockoff for 1 – 4-Pole Supplementary Protector	—	WAMPLK

Bus Bar Combs

Phases	Configuration	Length	Actual Length (mm)	Number of Devices	Bus Bar Catalog Number ①	End Cap Catalog Number
--------	---------------	--------	--------------------	-------------------	--------------------------	------------------------

Fork Connection

1-Phase	Device	Short	210	12 Unit	WBC1F12	Not Required
	Device	Long	100	57 Unit	WBC1F57	Not Required
	Device + Aux	Short	315	12 Unit	WBC1F12A	Not Required
	Device + Aux	Long	1000	37 Unit	WBC1F37A	Not Required
2-Phase	Device	Short	210	6 Unit	WBC2F6	WBCCAP10UL
	Device	Long	100	28 Unit	WBC2F28	WBCCAP10UL
	Device + Aux	Short	255	6 Unit	WBC2F6A	WBCCAP10UL
	Device + Aux	Long	1000	22 Unit	WBC2F22A	WBCCAP10UL
3-Phase	Device	Short	210	4 Unit	WBC3F4	WBCCAP10UL
	Device	Long	106	19 Unit	WBC3F19	WBCCAP10UL
	Device + Aux	Short	235	4 Unit	WBC3F4A	WBCCAP10UL
	Device + Aux	Long	1000	16 Unit	WBC3F16A	WBCCAP10UL

Pin Connection

1-Phase	Device	Short	210	12 Unit	WBC1P12	Not Required
	Device	Long	100	57 Unit	WBC1P57	Not Required
	Device + Aux	Short	315	12 Unit	WBC1P12A	Not Required
	Device + Aux	Long	1000	37 Unit	WBC1P37A	Not Required
2-Phase	Device	Short	210	6 Unit	WBC2P6	WBCCAP10CE
	Device	Long	100	28 Unit	WBC2P28	WBCCAP10CE
	Device + Aux	Short	210	6 Unit	WBC2P6A	WBCCAP10CE
	Device + Aux	Long	1000	22 Unit	WBC2P22A	WBCCAP10CE
3-Phase	Device	Short	210	4 Unit	WBC3P4	WBCCAP10CE
	Device	Long	106	19 Unit	WBC3P19	WBCCAP10CE
	Device + Aux	Short	235	4 Unit	WBC3P4A	WBCCAP10CE
	Device + Aux	Long	1000	16 Unit	WBC3P16A	WBCCAP10CE

① Each 2- and 3-phase bus bar comb is supplied complete with two end caps; additional end caps are available as an accessory.

Circuit & Motor Protection

Circuit Breakers

PRODUCT SELECTION

Miniature Circuit Breakers — Accessories

Bus Bar

Description	Pack Quantity	Catalog Number
-------------	---------------	----------------

End Caps ^①

For Use with 2- and 3-Phase Fork Bus Bars	10	WBCCAP10UL
For Use with 2- and 3-Phase Pin Bus Bars	10	WBCCAP10CE

Power Feed Lugs

Connection of Oversized Wires to Feed Bus Bar (50 mm ² / 10-1 AWG)	4	WBCPPL
Direct Connection to Feed Fork Bus Bar (35 mm ²)	4	WBCFPL

Bus Bar Tooth Cap

Shroud Unused Bus Bar Connection	10	WBCTCAP10
----------------------------------	----	------------------

^① Each 2- and 3-phase bus bar comb is supplied complete with two end caps.

SPHM Series Hydraulic Magnetic Circuit Breakers — Catalog Numbering System

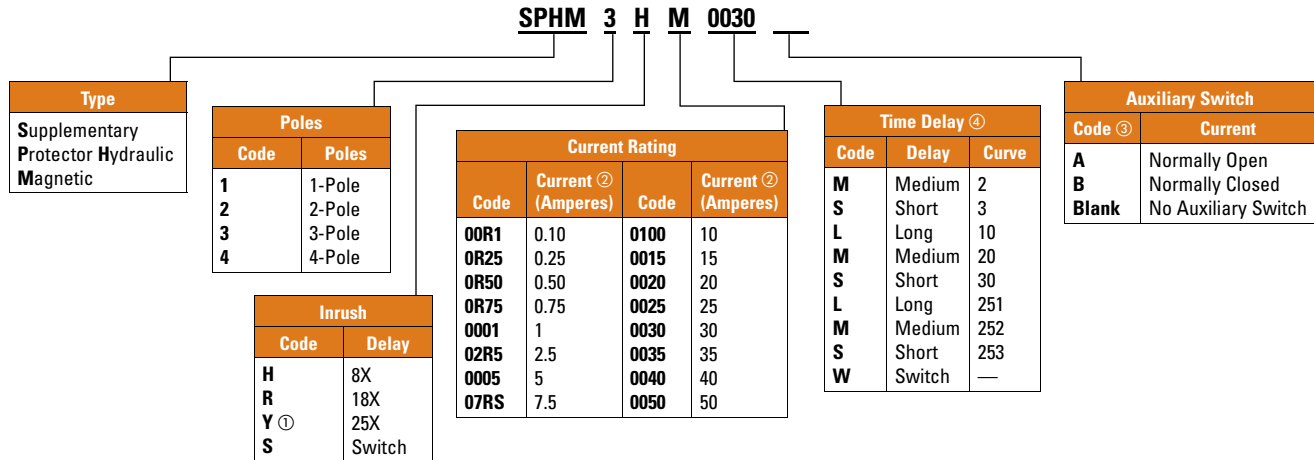

- ① Maximum of 40 amperes available at 25X inrush.
- ② UL recognized to 250V ac, 5 kA above 30 amperes.
- ③ One A or B contact maximum per pole. Contacts will be arranged left to right (e.g., BAB suffix on 3-pole breaker).
- ④ Specific data on trip curves can be found at www.eaton.com/heinemann.

SPHM Series Hydraulic Magnetic Circuit Breakers

- DIN-Rail mountable
- Optional integral auxiliary switch
- Bus bar for common feed and isolated connectors available
- Precision custom calibration
- Requires no derating (100% rated)
- Ambient compensating (-40°C to +85°C)
- Immediate reset after fault
- Provides equipment and wire protection



SPHM Standard

Poles	Current (Amperes)	Curve	Catalog Number
1	1	2	SPHM1RM0001
1	2.5	2	SPHM1RM02R5
1	5	2	SPHM1RM0005
1	7.5	2	SPHM1RM07R5
1	10	2	SPHM1RM0010
1	15	2	SPHM1RM0015
1	20	2	SPHM1RM0020
1	25	2	SPHM1RM0025
1	30	2	SPHM1RM0030
1	35	2	SPHM1RM0035
1	40	2	SPHM1RM0040
1	50	2	SPHM1RM0050
2	1	2	SPHM2RM0001
2	2.5	2	SPHM2RM02R5
2	5	2	SPHM2RM0005
2	7.5	2	SPHM2RM07R5
2	10	2	SPHM2RM0010
2	15	2	SPHM2RM0015

Poles	Current (Amperes)	Curve	Catalog Number
2	20	2	SPHM2RM0020
2	25	2	SPHM2RM0025
2	30	2	SPHM2RM0030
2	35	2	SPHM2RM0035
2	40	2	SPHM2RM0040
2	50	2	SPHM2RM0050
3	1	2	SPHM3RM0001
3	2.5	2	SPHM3RM02R5
3	5	2	SPHM3RM0005
3	7.5	2	SPHM3RM07R5
3	10	2	SPHM3RM0010
3	15	2	SPHM3RM0015
3	20	2	SPHM3RM0020
3	25	2	SPHM3RM0025
3	30	2	SPHM3RM0030
3	35	2	SPHM3RM0035
3	40	2	SPHM3RM0040
3	50	2	SPHM3RM0050

Circuit & Motor Protection

Circuit Breakers

CATALOG SELECTION / PRODUCT SELECTION

J Series Hydraulic Magnetic Circuit Breakers — Catalog Numbering System

JA1S A 3 A 0015 01 E

Style ①	Number of Poles	Description	Handle Color	Mounting
JA_S	1 to 4	Toggle Handle	White ON / OFF	6-32
JB_S	1 to 4	Snap-In Mount	White ON / OFF	N/A
JC_S	1 to 4	Rocker Handle	White ON / OFF	6-32
JE_S	1 to 3	Sealed Toggle	N/A	3/8-32

Voltage, Terminal and Frequency Code			
Code	Frequency	Terminal Location	Maximum Voltage
A	50/60 Hz	Push-On	277 ac
T	50/60 Hz	8-32 Screw	277 ac
K	50/60 Hz	10-32 Screw	277 ac
B	dc	Push-On	65 dc
V	dc	8-32 Screw	65 dc
L	dc	10-32 Screw	65 dc
D	60 Hz/dc	Push-On	250 ac/65 dc
E	60 Hz/dc	8-32 Screw	250 ac/65 dc
R	60 Hz/dc	10-32 Screw	250 ac/65 dc
C	400 Hz	Push-On	250 ac
W	400 Hz	8-32 Screw	250 ac
N	400 Hz	10-32 Screw	250 ac

Approval Code	
A	= Up to 250V ac UL 1077 Up to 65V dc UL 1077
L	= 277V ac UL 1077

Internal Circuit Type and Inrush Catalog Code				
N/A	STD	18X	25X	Internal Circuit
0	—	—	—	Switch Only
—	3	89	38	Series Trip
—	2	—	39	Series Trip w/Aux.
—	5	—	—	Shunt/Tap
—	6	—	—	Relay Trip

Current Rating ②	
Code	Current (Amperes)
0R02	0.02
0R10	0.10
0R25	0.25
0R50	0.50
0R75	0.75
0001	1
02R5	2.5
0005	5
07R5	7.5
0010	10
0015	15
0020	20
0025	25
0030	30
0040	40
0050	50

Voltage Rating	
E	= 0 – 250V ac
F	= 251 – 277V ac
G	= 415V ac ③
N	= 0 – 65V dc

Time Delay Curve ④	
0P	= Instant
01	= Long Delay Std. Inrush
02	= Medium
03	= Short
10	= Long Delay 18X Inrush
20	= Medium Delay 18X Inrush
30	= Short Delay 18X Inrush
251	= Long Delay 25X Inrush
252	= Medium Delay 25X Inrush
253	= Short Delay 25X Inrush

- ① Choose style and select from 1 to 4 poles, and enter the number in position 3 of the catalog number. For example, a JA1S would identify a 1-pole JA Series breaker.
- ② Enter the four digit current rating. For example, use code "0015" for a 15 ampere current rating. For fractional amperages, use an "R" to designate the decimal point. For 0.10 ampere, enter the code "0R10."
- ③ Non-standard.
- ④ Specific data on trip curves can be found at www.eaton.com/heinemann.

J Series Hydraulic Magnetic Circuit Breakers

- Small, lightweight UL 1077 circuit breaker
- Precision custom calibration
- Requires no derating (100% rated)
- Ambient compensating (-40°C to +85°C)
- Immediate reset after fault
- Broad range of integral internal accessories
- Provides equipment and wire protection



J Series Standard — 250V ac / 65V dc Push-On Terminals

Poles	Current (Amperes)	Curve	Catalog Number
1	1	2	JA1SD3A000102E
1	2.5	2	JA1SD3A02R502E
1	5	2	JA1SD3A000502E
1	7.5	2	JA1SD3A07R502E
1	10	2	JA1SD3A001002E
1	15	2	JA1SD3A001502E
1	20	2	JA1SD3A002002E
1	25	2	JA1SD3A002502E
1	30	2	JA1SD3A003002E
2	1	2	JA2SD3A000102E
2	2.5	2	JA2SD3A02R502E
2	5	2	JA2SD3A000502E
2	7.5	2	JA2SD3A07R502E
2	10	2	JA2SD3A001002E
2	15	2	JA2SD3A001502E

Poles	Current (Amperes)	Curve	Catalog Number
2	20	2	JA2SD3A002002E
2	25	2	JA2SD3A002502E
2	30	2	JA2SD3A003002E
3	1	2	JA3SD3A000102E
3	2.5	2	JA3SD3A02R502E
3	5	2	JA3SD3A000502E
3	7.5	2	JA3SD3A07R502E
3	10	2	JA3SD3A001002E
3	15	2	JA3SD3A001502E
3	20	2	JA3SD3A002002E
3	25	2	JA3SD3A002502E
3	30	2	JA3SD3A003002E

AMR Series Hydraulic Magnetic Circuit Breakers — Catalog Numbering System

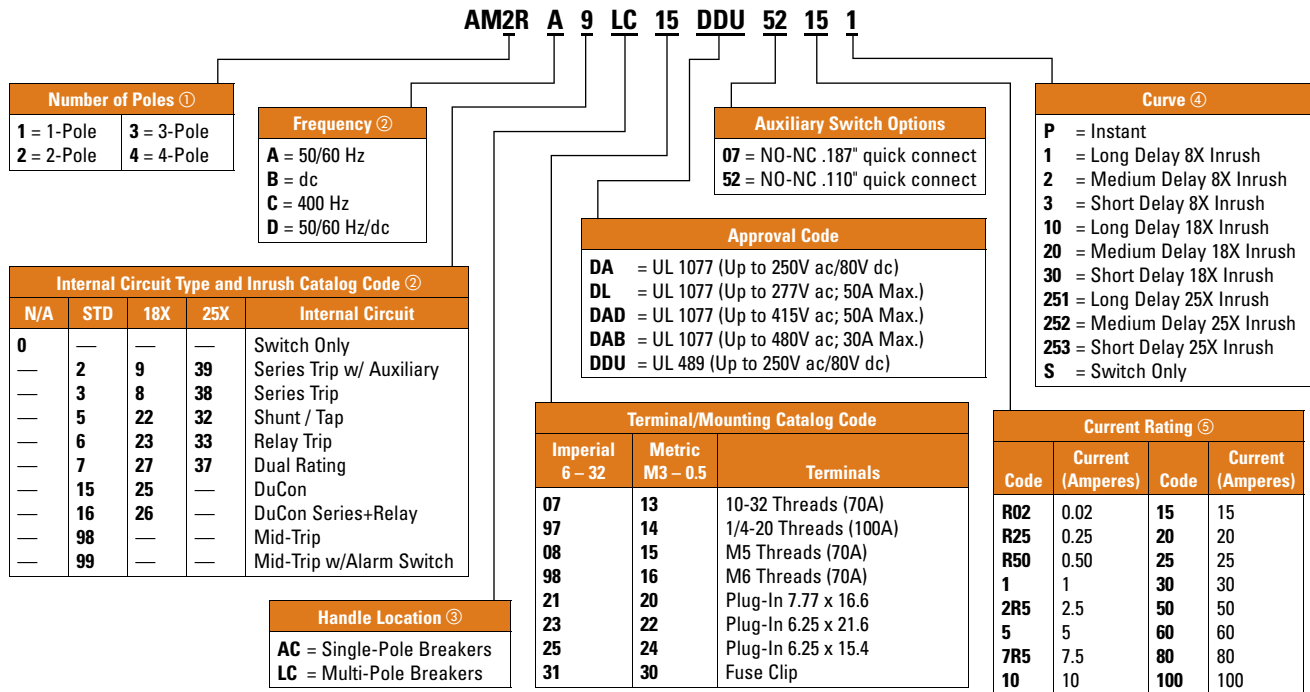

- ① Select from 1 to 4 poles, and enter the number in position 3 of the catalog number. For example, an AM3RL would identify a 3-pole AMRL breaker.
- ② On multi-pole breakers, Steps 2 and 3 can be repeated if subsequent poles are different than the first. Identification starts from left-hand side when viewing the front of the breaker.
- ③ These will provide a handle on each pole.
- ④ Specific data on trip curves can be found at www.eaton.com/heinemann.
- ⑤ Enter the whole number current rating. For example, use code "15" for a 15 A current rating. For fractional amperages, use an "R" to designate the decimal point. For 0.10 A, enter the code "R10." Current range up to 100 amperes 50/60 Hz, 60 amperes 400 Hz, 100A dc.

AMR Series Hydraulic Magnetic Circuit Breakers

- Precision custom calibration
- Requires no derating (100% rated)
- Ambient compensating (-40°C to +85°C)
- Immediate reset after fault
- Broad range of integral internal accessories
- Provides equipment and wire protection



AMR Standard Black Toggle

Current (Amperes)	Curve	1-Pole Catalog Number	2-Pole Catalog Number	3-Pole Catalog Number
1	2	AM1RA3AC07DA12	AM2RA3AC07DA12	AM3RA3AC07DA12
2.5	2	AM1RA3AC07DA2R52	AM2RA3AC07DA2R52	AM3RA3AC07DA2R52
5	2	AM1RA3AC07DA52	AM2RA3AC07DA52	AM3RA3AC07DA52
7.5	2	AM1RA3AC07DA7R52	AM2RA3AC07DA7R52	AM3RA3AC07DA7R52
10	2	AM1RA3AC07DA102	AM2RA3AC07DA102	AM3RA3AC07DA102
15	2	AM1RA3AC07DA152	AM2RA3AC07DA152	AM3RA3AC07DA152
20	2	AM1RA3AC07DA202	AM2RA3AC07DA202	AM3RA3AC07DA202
30	2	AM1RA3AC07DA302	AM2RA3AC07DA302	AM3RA3AC07DA302
50	2	AM1RA3AC07DA502	AM2RA3AC07DA502	AM3RA3AC07DA502
80	2	AM1RA3AC97DA802	AM2RA3AC97DA802	AM3RA3AC97DA802

Circuit & Motor Protection

Circuit Breakers

CATALOG SELECTION

Series NRX Low Voltage Power Breaker — Positions 1 – 8 — Catalog Numbering System

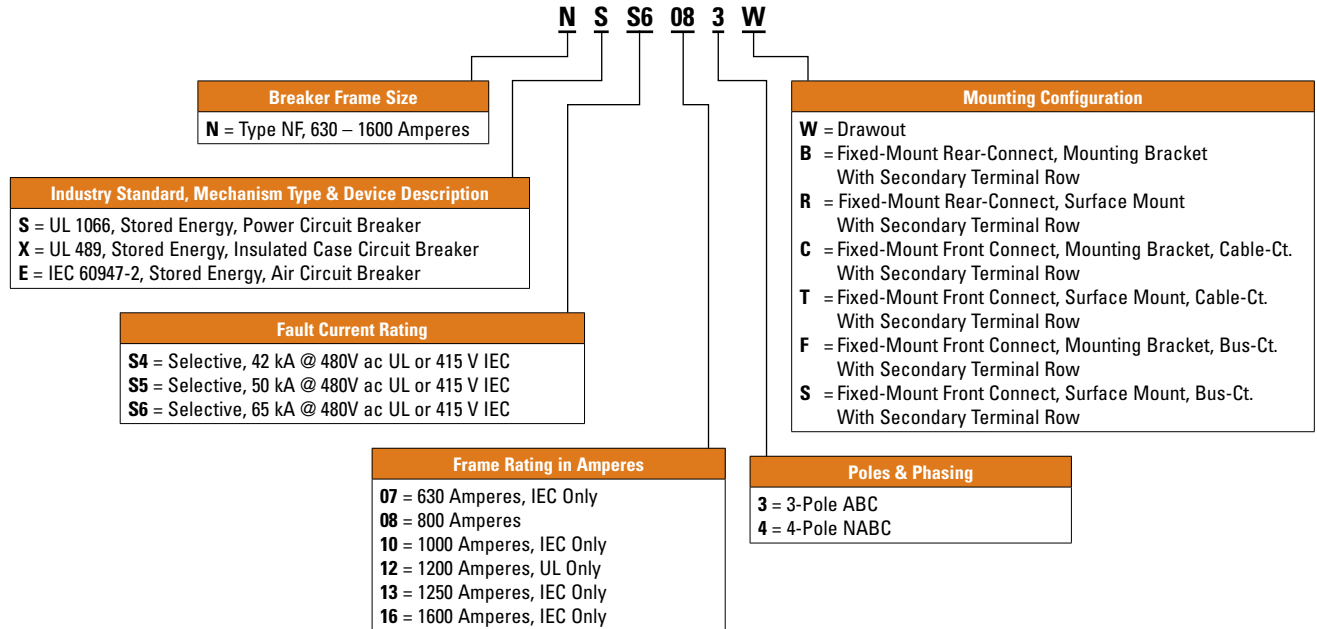

Series NRX Low Voltage Cassette — Catalog Numbering System

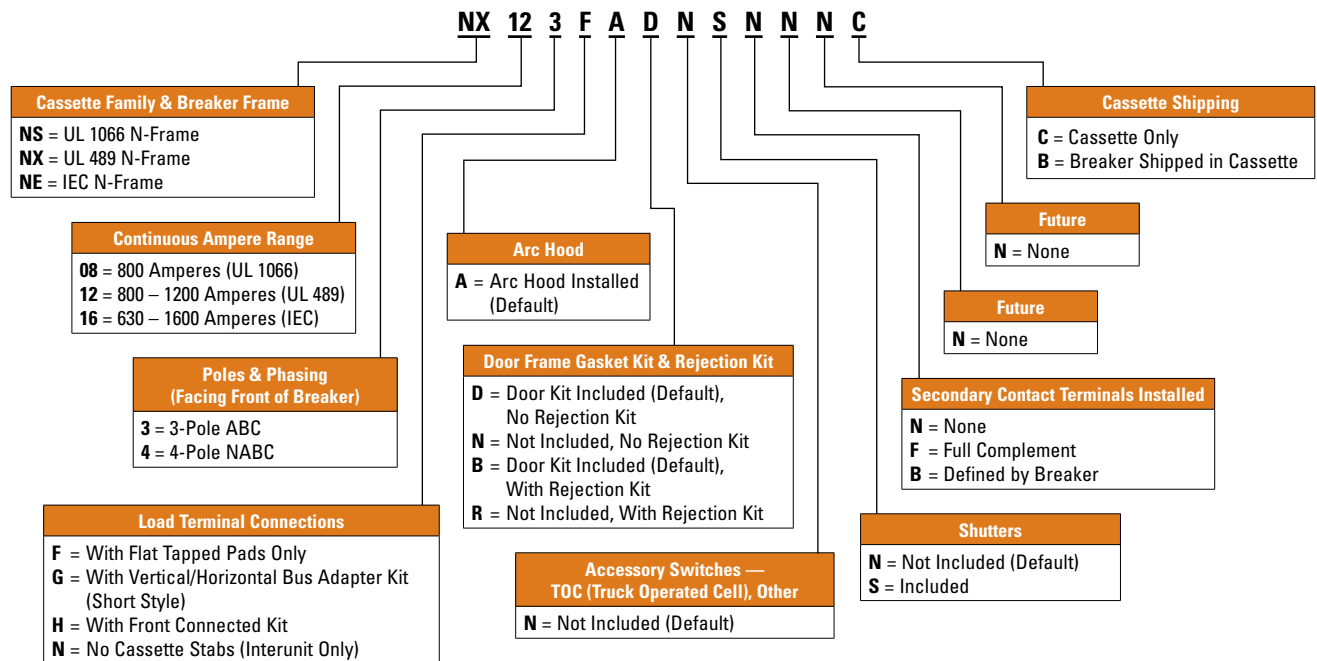

Circuit & Motor Protection

Circuit Breakers CATALOG SELECTION

Series NRX Low Voltage Power Breaker — Positions 9 – 20 — Catalog Numbering System

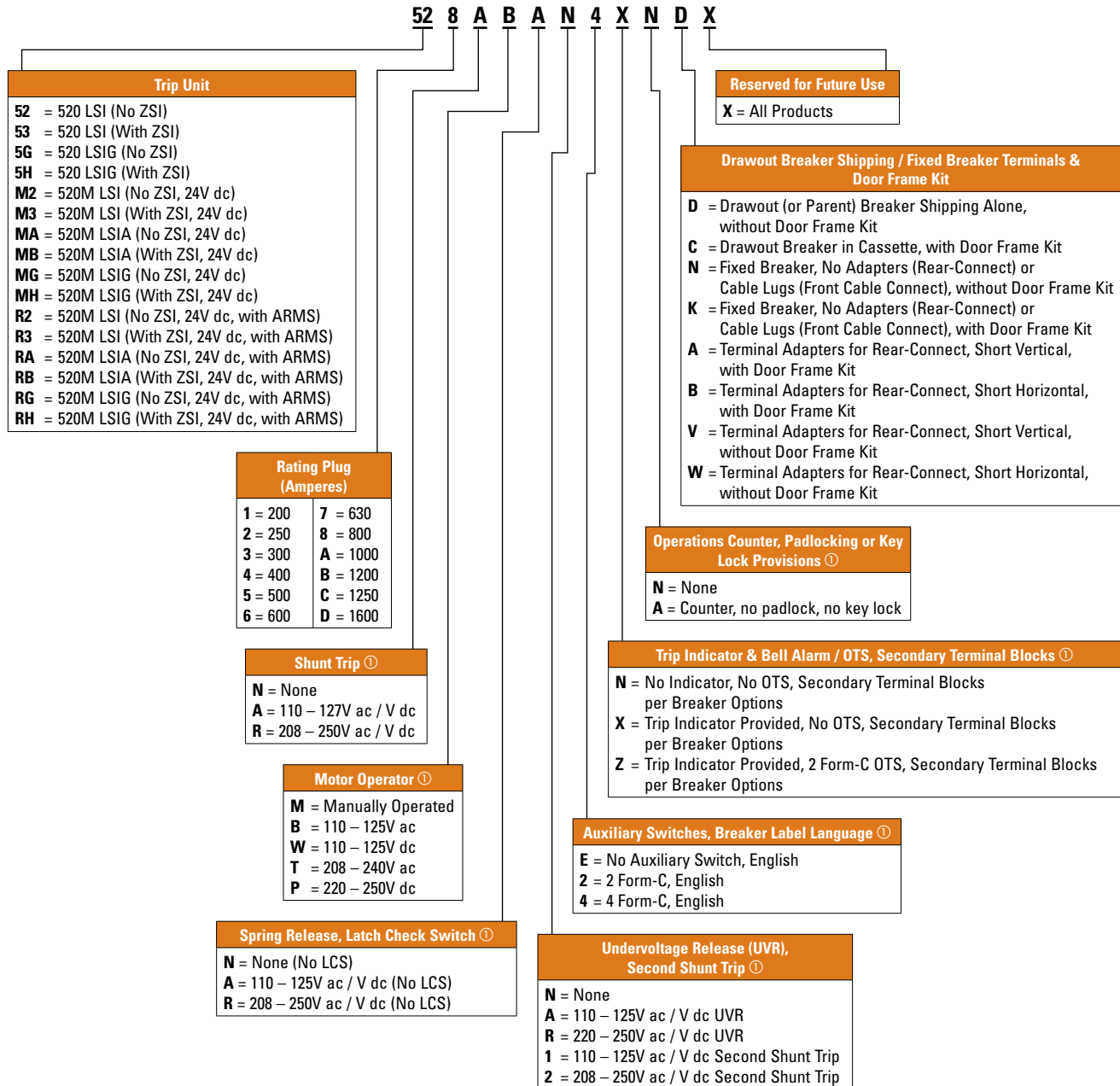

① Contact Eaton for available voltages. Not all voltages are currently available.

Circuit & Motor Protection

Circuit Breakers

PRODUCT SELECTION

Series NRX™ Low Voltage Power Breaker

- Rogowski coil does not saturate like iron core sensors, and one sensor accommodates 200 – 1600 amp range. Never change a sensor, and NO CTs are required.
- Tension clamp secondary terminals — 10A continuous rating at 600V meets UL / CSA / RoHS and UL-94 V0. Mounted directly to fixed breaker or drawout cassette they reduce wiring and provide clean, organized wiring schemes.
- Breaker mounted communication modules for INCOM, Modbus and PROFIBUS mount directly to the cassette, reducing the space and room required for communication capability.
- With the patent pending simple design of the fold-up cassette, all items in a cassette are replaceable without removing the cassette from the cell.
- Plug-and-play accessories — No special tools needed. Accessories come with plug and wires ready to install.



Series NRX Low Voltage Power Breaker

Breaker Frame	Industry Standard	Fault Current Rating (kAIC)	Frame Rating in Amperes	Poles	Mounting	Trip Unit	Rating Plug	Part Number
N	UL 1066	42	800	3	Drawout ②	520 LSI (No ZSI)	800	NSS4083W528 ①
N	UL 1066	42	800	4	Fixed	520 LSI (No ZSI)	800	NSS4084B528 ①
N	UL 1066	50	800	3	Drawout ②	520 LSI (No ZSI)	800	NSS5083W528 ①
N	UL 1066	50	800	4	Fixed	520 LSI (No ZSI)	800	NSS5084B528 ①
N	UL 1066	65	800	3	Drawout ②	520 LSI (No ZSI)	800	NSS6083W528 ①
N	UL 1066	65	800	3	Fixed	520 LSI (No ZSI)	800	NSS6083B528 ①
N	UL 1066	65	800	4	Drawout ②	520 LSI (No ZSI)	800	NSS6084W528 ①
N	UL 1066	65	800	4	Fixed	520 LSI (No ZSI)	800	NSS6084B528 ①
N	UL 489	42	800	3	Drawout ②	520 LSI (No ZSI)	800	NXS4083W528 ①
N	UL 489	42	1200	4	Drawout ②	520 LSI (No ZSI)	1200	NXS4124W52B ①
N	UL 489	50	800	3	Fixed	520 LSI (No ZSI)	800	NXS5083B528 ①
N	UL 489	50	1200	4	Fixed	520 LSI (No ZSI)	1200	NXS5124B528 ①
N	UL 489	65	800	3	Drawout ②	520 LSI (No ZSI)	800	NXS6083W528 ①
N	UL 489	65	800	4	Fixed	520 LSI (No ZSI)	800	NSS6084B528 ①
N	UL 489	65	1200	3	Drawout ②	520 LSI (No ZSI)	1200	NXS6123W52B ①
N	UL 489	65	1200	4	Fixed	520 LSI (No ZSI)	1200	NXS6124B52B ①
N	IEC	42	630	3	Drawout ②	520 LSI (No ZSI)	630	NES4073W527 ①
N	IEC	42	1600	4	Drawout ②	520 LSI (No ZSI)	1600	NES4164W52D ①
N	IEC	50	630	3	Fixed	520 LSI (No ZSI)	630	NES5073B527 ①
N	IEC	50	1600	4	Fixed	520 LSI (No ZSI)	1600	NES5164B52D ①
N	IEC	65	630	3	Drawout ②	520 LSI (No ZSI)	630	NES6073W527 ①
N	IEC	65	800	4	Fixed	520 LSI (No ZSI)	800	NES6084B528 ①
N	IEC	65	1250	3	Fixed	520 LSI (No ZSI)	1250	NES6133B52C ①
N	IEC	65	1600	4	Drawout ②	520 LSI (No ZSI)	1600	NES6164W52D ①

① See Page 33 for selection of accessories in positions 12 – 20.

② See Page 32 for cassette selection for drawout breakers.

Circuit & Motor Protection

Circuit Breakers

CATALOG SELECTION

Magnum Low Voltage Power Breaker Cassette — Catalog Numbering System

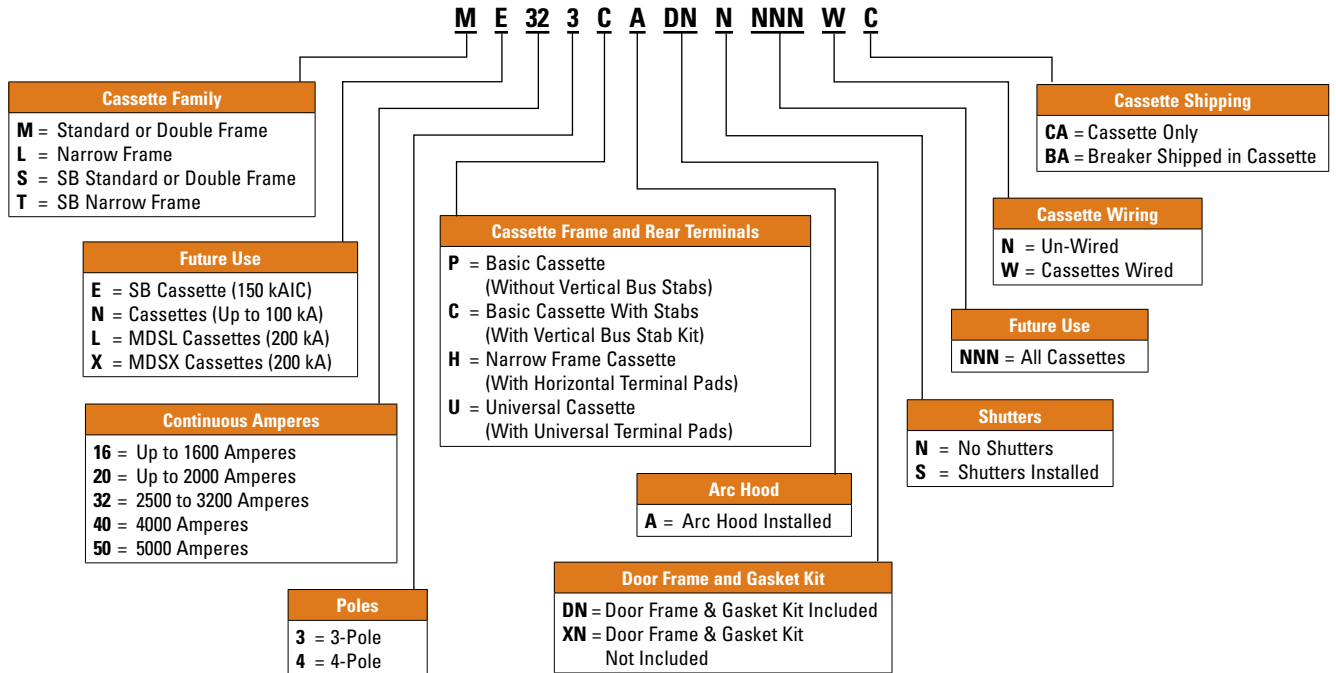

Magnum® Low Voltage Power Breaker

- Rated up to 6300A with interrupting ratings up to 200 kAIC and withstand ratings up to 100 kAIC
- Magnum DS is UL 1066 listed for one-half second short-time withstand rating, and rated for 30 cycles. It is a switchgear class product to meet UL 1558 switchgear standards
- Magnum SB is a UL 1066 listed product with one-half second short-time withstand rating at 3 cycles to meet switchboard class product specifications, such as UL 891
- Magnum DS MDDX is the highest interrupting performance in a non-current limiting breaker construction rated up to 200 kAIC with 100 kAIC short-time withstand
- The Magnum DS, Magnum SB and Magnum IEC lines all offer the smallest double narrow 4000A frame available



Magnum DS Switchgear Class UL 1066 Low Voltage Power Circuit Breakers

Frame Type	RMS Symmetrical Current Ratings kA 50/60 Hz ①			Short Time Current Rating	Frame Amperes	Breaker Type ②
	Interrupting at 254V ac	Interrupting at 508V ac	Interrupting at 635V ac			
Narrow	42	42	42	42	800	MDN-408
Narrow	50	50	50	50		MDN-508
Narrow	65	65	65	65		MDN-608
Narrow	100	100	65	20		MDN-C08
Standard	42	42	42	42	800	MDS-408
Standard	65	65	65	65		MDS-608
Standard	85	85	85	85		MDS-808
Standard	100	100	100	85		MDS-C08
Standard	200	200	200	—		MDS-L08 ④
Standard	200	200	③	30		MDS-X08 ⑤⑥
Narrow	42	42	42	42	1600	MDN-416
Narrow	50	50	50	50		MDN-516
Narrow	65	65	65	65		MDN-616
Narrow	100	100	65	30		MDN-C16
Standard	65	65	65	65	1600	MDS-616
Standard	85	85	85	85		MDS-816
Standard	100	100	100	85		MDS-C16
Standard	200	200	200	—		MDS-L16 ④
Standard	200	200	③	30		MDS-X16 ⑤
Narrow	65	65	65	65	2000	MDN-620
Narrow	100	100	65	35		MDN-C20
Standard	65	65	65	65	2000	MDS-620
Standard	85	85	85	85		MDS-820
Standard	100	100	100	85		MDS-C20
Standard	200	200	200	—		MDS-L20 ④
Standard	200	200	③	30		MDS-X20 ⑤
Standard	65	65	65	65	3200	MDS-632
Standard	85	85	85	85		MDS-832
Standard	100	100	100	85		MDS-C32
Double	200	200	③	50	3200	MDS-X32 ⑤

① Interrupting ratings shown based on breaker equipped with integral Digitrip RMS Trip Unit. Interruption ratings for non-automatic breakers are equal to the published Short Time Current Rating. These interruption ratings are based on the standard duty cycle consisting of an open operation, a 15-second interval and a close-open operation, in succession, with delayed tripping in case of short-delay devices. The standard duty cycle for short time ratings consists of maintaining the rated current for two periods of 1/2 seconds each, with a 15-second interval of zero current between the two periods.

① See Page 35 for selection of trip unit and accessories. See Page 36 for cassette selection for drawout breakers.

② Product to be tested. Contact Eaton for product rating.

③ Magnum MDSL current limiting power circuit breaker with integral current limiters. Current limiter selected determines short time and maximum instantaneous trip rating. Maximum voltage rating is 600V ac.

④ Magnum MDSX current limiting power circuit breaker with fast opening contacts.

⑤ Check with Eaton for availability.

Circuit & Motor Protection

Circuit Breakers

PRODUCT SELECTION

Magnum Low Voltage Power Breaker

Magnum DS Switchgear Class UL 1066 Low Voltage Power Circuit Breakers (Continued)

Frame Type	RMS Symmetrical Current Ratings kA 50/60 Hz ①			Short Time Current Rating	Frame Amperes	Breaker Type ②
	Interrupting at 254V ac	Interrupting at 508V ac	Interrupting at 635V ac			
Double (N)	85	85	③	85	4000	MDN-840 MDN-C40
Double (N)	100	100		100		
Double	85	85	85	85	4000	MDS-840 MDS-C40 MDS-X40 ④
Double	100	100	100	100		
Double	200	200	③	50		
Double	200	200	③	100	4000	MDD-X40
Double	85	85	85	85	5000	MDS-850 MDS-C50 MDS-X50 ④⑤
Double	100	100	100	100		
Double	200	200	③	50		
Double	200	200	③	100	5000	MDD-X50
Double	100	100	100	100	6000	MDS-C60 ⑤
Double	200	200	③	100	6000	MDD-X60

① Interrupting ratings shown based on breaker equipped with integral Digitrip RMS Trip Unit. Interruption ratings for non-automatic breakers are equal to the published Short Time Current Rating. These interruption ratings are based on the standard duty cycle consisting of an open operation, a 15-second interval and a close-open operation, in succession, with delayed tripping in case of short-delay devices. The standard duty cycle for short time ratings consists of maintaining the rated current for two periods of 1/2 seconds each, with a 15-second interval of zero current between the two periods.

- ② See Page 35 for selection of trip unit and accessories. See Page 36 for cassette selection for drawout breakers.
- ③ Product to be tested. Contact Eaton for product rating.
- ④ Magnum MDSX current limiting power circuit breaker with fast opening contacts.
- ⑤ Breaker applied in a tested fan-cooled enclosure.

Magnum SB Switchboard Class UL 1066 Insulated Case Low Voltage Power Circuit Breakers

Frame Type	RMS Symmetrical Current Ratings kA 50/60 Hz ①			Short Time Current Rating	Frame Amperes	Breaker Type
	Interrupting at 254V ac	Interrupting at 508V ac	Interrupting at 635V ac			
Narrow	50	50	35	20	800	SBN-508 SBN-608 SBN-C08
Narrow	65	65	42	20		
Narrow	100	100	65	20		
Standard	65	65	65	20	800	SBS-608 SBS-C08 SBS-E08 ③
Standard	100	100	85	20		
Standard	200	150	②	30		
Narrow	50	50	35	25	1200	SBN-512 SBN-612 SBN-C12
Narrow	65	65	42	25		
Narrow	100	100	65	25		
Standard	65	65	65	25	1200	SBS-612 SBS-C12 SBS-E12 ③
Standard	100	100	85	25		
Standard	200	150	②	30		
Narrow	50	50	35	30	1600	SBN-516 SBN-616 SBN-C16
Narrow	65	65	42	30		
Narrow	100	100	65	30		
Standard	65	65	65	30	1600	SBS-616 SBS-C16 SBS-E16 ③
Standard	100	100	85	30		
Standard	200	150	②	30		
Narrow	65	65	65	35	2000	SBN-620 SBN-C20
Narrow	100	100	65	35		
Standard	65	65	65	35	2000	SBS-620 SBS-C20 SBS-E20 ③
Standard	100	100	85	35		
Standard	200	150	②	30		

① Interrupting ratings shown based on breaker equipped with integral Digitrip RMS Trip Unit. Interruption ratings for non-automatic breakers are equal to the published Short Time Current Rating. These interruption ratings are based on the standard duty cycle consisting of an open operation, a 15-second interval and a close-open operation, in succession, with delayed tripping in case of short-delay devices. The standard duty cycle for short time ratings consists of maintaining the rated current for two periods of 1/2 seconds each, with a 15-second interval of zero current between the two periods.

- ② Product to be tested. Contact Eaton for product rating.
- ③ Magnum SBSE current limiting power circuit breaker with fast opening contacts.

Magnum Low Voltage Power Breaker

Magnum SB Switchboard Class UL 1066 Insulated Case Low Voltage Power Circuit Breakers (Continued)

Frame Type	RMS Symmetrical Current Ratings kA 50/60 Hz ①				Frame Amperes	Breaker Type
	Interrupting at 254V ac	Interrupting at 508V ac	Interrupting at 635V ac	Short Time Current Rating		
Standard	65	65	65	45	2500	SBS-625
Standard	100	100	85	45		SBS-C25
Double	200	150	②	50		SBS-E25 ③
Standard	65	65	65	50	3000	SBS-630
Standard	100	100	85	50		SBS-C30
Double	200	150	②	50		SBS-E30 ③
Double (N)	85	85	③	85	4000	SBN-840
Double (N)	100	100	③	100		SBN-C40
Double	85	85	85	85		SBS-840
Double	100	100	100	100	5000	SBS-C40
Double	200	150	②	50		SBS-E40 ③
Double	85	85	85	85		SBS-850
Double	100	100	100	100	6000	SBS-C50
Double	200	150	②	50		SBS-E50 ③④
Double	100	100	100	100		SBS-C60 ④

① Interrupting ratings shown based on breaker equipped with integral Digitrip RMS Trip Unit. Interruption ratings for non-automatic breakers are equal to the published Short Time Current Rating. These interruption ratings are based on the standard duty cycle consisting of an open operation, a 15-second interval and a close-open operation, in succession, with delayed tripping in case of short-delay devices. The standard duty cycle for short time ratings consists of maintaining the rated current for two periods of 1/2 seconds each, with a 15-second interval of zero current between the two periods.

② Product to be tested. Contact Eaton for product rating.

③ Magnum SBSE current limiting power circuit breaker with fast opening contacts.

④ Breaker applied in a tested fan-cooled enclosure

Compact All-in-One Solutions



EATON

Powering Business Worldwide





- Eliminate the overload relay with a manual motor protector or combination motor controller
- Get a disconnect, starter, and overload and motor protection in one compact device
- A complete motor protector and remote control solution easily assembled
- UL 508F ratings means no need for protection upstream when using a combination motor controller

Circuit & Motor Protection

Manual Motor Protectors & Controllers

PRODUCT OVERVIEW

Manual Motor Protectors & Controllers Product Overview

				
Description	XTPB Pushbutton Manual Motor Protector	XTPR Rotary Manual Motor Protector	XTSC Manual Motor Controller	XTFC Combination Motor Controller
Page	Page 42	Page 42	Page 49	Page 49
Operator Style	Pushbutton	Rotary	Rotary	Rotary
Components	Manual Motor Protector	Manual Motor Protector	Manual Motor Protector Contactor Connector Kit	Manual Motor Protector Contactor Connector Kit Line Side Adapter
UL 508 Type E	—	Yes, Line Side Adapter	—	—
UL 508 Type F	—	—	—	Yes, Line Side Adapter
Branch Motor Circuit Functions	Disconnect Controller (manual) Short Circuit Protection Motor Overload Protection	Disconnect Controller (manual) Short Circuit Protection Motor Overload Protection	Disconnect Controller (manual & remote) Short Circuit Protection Motor Overload Protection	Disconnect Controller (manual & remote) Short Circuit Protection Motor Overload Protection
FLA Range	0.1 – 25A	0.1 – 65A	0.1 – 65A	0.1 – 65A

Circuit & Motor Protection

Manual Motor Protectors & Controllers

CATALOG SELECTION

XT IEC Manual Motor Protectors — Catalog Numbering System

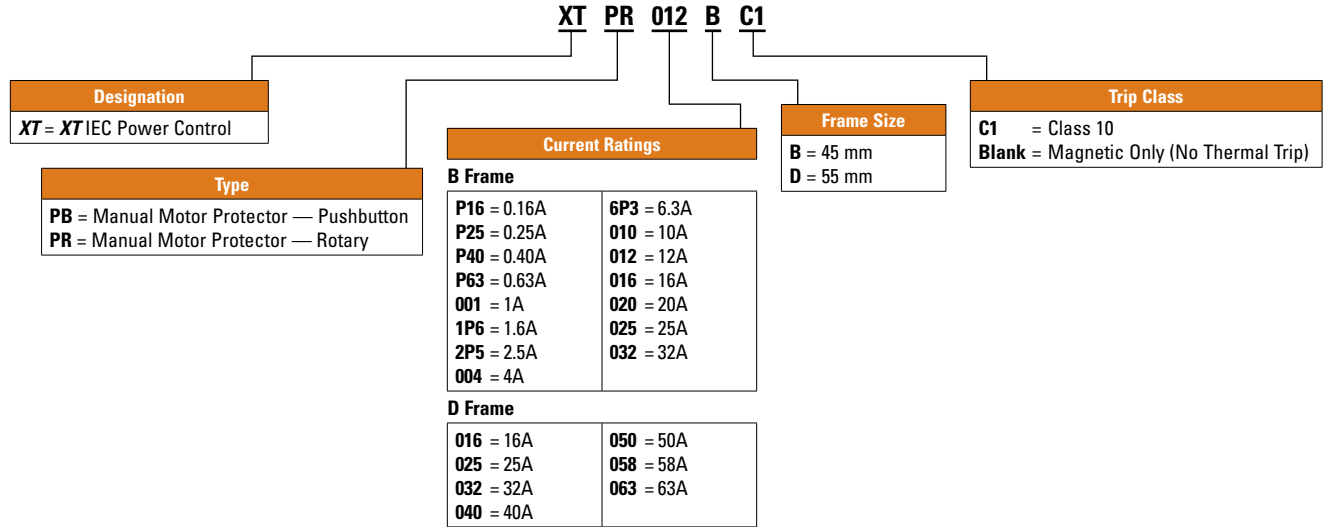

Circuit & Motor Protection

Manual Motor Protectors & Controllers

PRODUCT SELECTION

XT IEC Manual Motor Protectors

- ON / OFF rotary handle with lockout provision
- Class 10 overload protection
- Motor applications from 0.1A to 63A
- Built-in heater and magnetic trip elements to protect the motor
- Adjustment dial for setting motor FLA
- XTPR Rotary MMP with a lineside adapter is rated for UL 508 Type E



XTPB Pushbutton Manual Motor Protectors — Global and North American Ratings

Motor Protective Device with Thermal and Magnetic Trip

Rated Uninterrupted Current — $I_u = I_c$ (Amps)	FLA Adjustment Range / Overload Release — I_r (Amps)	Short Circuit Release — I_m (Amps)	Maximum Motor Ratings ①										Catalog Number — Screw Terminals
			Maximum kW Rating AC-3 — P (kW)					Maximum hp Rating — P (hp) UL 508 / CSA C 22.2 No. 14					
			3-Phase					3-Phase					
			220 – 240V	380 – 415V	440V	500V	660 – 690V	200V	240V	480V	600V		

Frame B

0.16	0.1 – 0.16	2.2	—	—	—	—	0.06	②	②	②	②	XTPBP16BC1
0.25	0.16 – 0.25	3.5	—	0.06	0.06	0.06	0.12	②	②	②	②	XTPBP25BC1
0.4	0.25 – 0.4	5.6	0.06	0.09	0.12	0.12	0.18	②	②	②	②	XTPBP40BC1
0.63	0.4 – 0.63	8.8	0.09	0.12	0.18	0.25	0.25	②	②	②	②	XTPBP63BC1
1	0.63 – 1	14	0.12	0.25	0.25	0.37	0.55	②	②	1/2	1/2	XTPB001BC1
1.6	1 – 1.6	22	0.25	0.55	0.55	0.75	1.1	②	②	3/4	1	XTPB1P6BC1
2.5	1.6 – 2.5	35	0.37	0.75	1.1	1.1	1.5	1/2	1/2	1	1-1/2	XTPB2P5BC1
4	2.5 – 4	56	0.75	1.5	1.5	2.2	3	1	1	2	3	XTPB004BC1
6.3	4 – 6.3	88	1.1	2.2	3	3	4	1-1/2	1-1/2	3	5	XTPB6P3BC1
10	6.3 – 10	140	2.2	4	4	4	7.5	3	3	7-1/2	10	XTPB010BC1
12	8 – 12	168	3	5.5	5.5	5.5	11	3	3	7-1/2	10	XTPB012BC1
16	10 – 16	224	4	7.5	9	9	12.5	3	5	10	10	XTPB016BC1
20	16 – 20	280	5.5	9	11	12.5	15	5	5	10	15	XTPB020BC1
25	20 – 25	350	5.5	12.5	12.5	15	22	5	7-1/2	15	20	XTPB025BC1

① Select manual motor protectors by full load amperes. Maximum motor ratings (kW, hp) are for reference only.

② In this range, calculate motor rating according to rated current. Specified values to NEC 430.6(A)(1).

Note: Service Factor (SF) — Setting I_r of current scale in dependence of load factor:

$$SF = 1.15 \rightarrow I_r = 1 \times I_n \text{ mot}$$

$$SF = 1 \rightarrow I_r = 0.9 \times I_n \text{ mot}$$

Circuit & Motor Protection

Manual Motor Protectors & Controllers

PRODUCT SELECTION

XT IEC Manual Motor Protectors

XTPR Rotary Manual Motor Protectors with Screw Terminals — Global Ratings and North American Ratings

Motor Protective Device with Thermal and Magnetic Trip

Rated Uninterrupted Current — $I_n = I_r$ (Amps)	FLA Adjustment Range / Overload Release — I_r (Amps)	Short Circuit Release — I_{rm} (Amps)	Maximum Motor Ratings ①										Catalog Number — Screw Terminals ③
			Maximum kW Rating AC-3 — P (kW)					Maximum hp Rating — P (hp) UL 508 / CSA C 22.2 No. 14					
			3-Phase					3-Phase					
			220 – 240V	380 – 415V	440V	500V	660 – 690V	200V	240V	480V	600V		

Frame B

0.16	0.1 – 0.16	2.2	—	—	—	—	0.06	②	②	②	②	XTPRP16BC1
0.25	0.16 – 0.25	3.5	—	0.06	0.06	0.06	0.12	②	②	②	②	XTPRP25BC1
0.4	0.25 – 0.4	5.6	0.06	0.09	0.12	0.12	0.18	②	②	②	②	XTPRP40BC1
0.63	0.4 – 0.63	8.8	0.09	0.12	0.18	0.25	0.25	②	②	②	②	XTPRP63BC1
1	0.63 – 1	14	0.12	0.25	0.25	0.37	0.55	②	②	1/2	1/2	XTPR001BC1
1.6	1 – 1.6	22	0.25	0.55	0.55	0.75	1.1	②	②	3/4	1	XTPR1P6BC1
2.5	1.6 – 2.5	35	0.37	0.75	1.1	1.1	1.5	1/2	1/2	1	1-1/2	XTPR2P5BC1
4	2.5 – 4	56	0.75	1.5	1.5	2.2	3	1	1	2	3	XTPR004BC1
6.3	4 – 6.3	88	1.1	2.2	3	3	4	1-1/2	1-1/2	3	5	XTPR6P3BC1
10	6.3 – 10	140	2.2	4	4	4	7.5	3	3	7-1/2	10	XTPR010BC1
12	8 – 12	168	3	5.5	5.5	5.5	11	3	3	7-1/2	10	XTPR012BC1
16	10 – 16	224	4	7.5	9	9	12.5	3	5	10	10	XTPR016BC1
20	16 – 20	280	5.5	9	11	12.5	15	5	5	10	15	XTPR020BC1
25	20 – 25	350	5.5	12.5	12.5	15	22	5	7-1/2	15	20	XTPR025BC1
32	25 – 32	448	7.5	15	15	22	30	7-1/2	10	25	30	XTPR032BC1

Frame D

16	10 – 16	224	4	7.5	9	9	12.5	3	5	10	15	XTPR016DC1
25	16 – 25	350	5.5	12.5	12.5	15	22	7-1/2	7-1/2	20	25	XTPR025DC1
32	25 – 32	448	7.5	15	17.5	22	22	10	10	25	30	XTPR032DC1
40	32 – 40	560	11	20	22	24	30	10	15	30	40	XTPR040DC1
50	40 – 50	700	14	25	30	30	45	10	15	30	40	XTPR050DC1
58	50 – 58	812	17	30	37	37	55	—	—	40	—	XTPR058DC1
65	55 – 65	882	18.5	34	37	45	55	—	—	—	—	XTPR063DC1

① Select manual motor protectors by full load amperes. Maximum motor ratings (kW, hp) are for reference only.

② In this range, calculate motor rating according to rated current. Specified values to NEC 430.6(A)(1).

③ Catalog number shown comes with screw terminals. For Frame B devices up to 16A, spring cage terminals are available.

For spring cage terminals on line and load sides, insert a "C" into the catalog number in the 5th position — Example: XTPRC _BC1.

For spring cage terminals on the load side only, insert an "SC" into the catalog number in the 5th and 6th positions — Example: XTPrSC _BC1.

Note: Service Factor (SF) — Setting I_r of current scale in dependence of load factor:

$$SF = 1.15 \rightarrow I_r = 1 \times I_{n \text{ mot}}$$

$$SF = 1 \rightarrow I_r = 0.9 \times I_{n \text{ mot}}$$

Circuit & Motor Protection

Manual Motor Protectors & Controllers

PRODUCT SELECTION

XT IEC Manual Motor Protectors

XTPR Manual Self-Protected Motor Starters — North American Ratings, UL 508 Type E ①

Motor Protective Device with Thermal and Magnetic Trip

Rated Uninterrupted Current — I_n (Amps)	FLA Adjustment Range / Overload Release — I_r (Amps)	Short Circuit Release — I_m (Amps)	Maximum Motor Ratings ②				Rated Short-Circuit Breaking Capacity (kA)			Line Side Adapter ①	Manual Motor Protector — Screw Terminals
			Maximum hp Rating — P (hp)				240V	480/277V	600/347V		
			3-Phase								
			200V	240V	480V/277V	600V/247V	240V	480/277V	600/347V	Catalog Number	Catalog Number

Frame B

0.16	0.1 – 0.16	2.2	③	③	1/2	1/2	50	50	50	XTPAXLSA	XTPRP16BC1
0.25	0.16 – 0.25	3.4	③	③	1/2	1/2	50	50	50	XTPAXLSA	XTPRP25BC1
0.4	0.25 – 0.4	5.6	③	③	1/2	1/2	50	50	50	XTPAXLSA	XTPRP40BC1
0.63	0.4 – 0.63	8.8	③	③	1/2	1/2	50	50	50	XTPAXLSA	XTPRP63BC1
1	0.63 – 1	14	③	③	1/2	1/2	50	50	50	XTPAXLSA	XTPR001BC1
1.6	1 – 1.6	22	③	③	3/4	3/4	50	50	50	XTPAXLSA	XTPR1P6BC1
2.5	1.6 – 2.5	35	1/2	1/2	1	1-1/2	50	50	50	XTPAXLSA	XTPR2P5BC1
4	2.5 – 4	56	3/4	1	2	3	50	50	50	XTPAXLSA	XTPR004BC1
6.3	4 – 6.3	88	1	1-1/2	3	5	50	50	50	XTPAXLSA	XTPR6P3BC1
10	6.3 – 11	140	3	3	7-1/2	10	50	50	50	XTPAXLSA	XTPR10BC1
12	8 – 12	168	3	3	7-1/2	—	42	42	—	XTPAXLSA	XTPR012BC1
16	10 – 16	224	3	5	10	—	42	42	—	XTPAXLSA	XTPR016BC1
20	16 – 20	280	5	5	—	—	42	42	—	XTPAXLSA	XTPR020BC1
25	20 – 25	350	5	7-1/2	15	—	18	18	—	XTPAXLSA	XTPR025BC1
32	25 – 32	448	7-1/2	10	25	—	18	18	—	XTPAXLSA	XTPR032BC1

Frame D

16	10 – 16	224	3	5	10	10	50	50	50	XTPAXLSAD	XTPR016DC1
25	16 – 25	350	7-1/2	7-1/2	20	25	50	50	50	XTPAXLSAD	XTPR025DC1
32	25 – 32	448	10	10	25	30	50	50	50	XTPAXLSAD	XTPR032DC1
40	32 – 40	560	10	10	30	40	50	50	50	XTPAXLSAD	XTPR040DC1
50	40 – 50	700	10	15	30	—	65	65	—	XTPAXLSAD	XTPR050DC1
58	50 – 58	812	15	15	40	—	65	65	—	XTPAXLSAD	XTPR058DC1
65	55 – 65	882	15	15	40	—	65	65	—	XTPAXLSAD	XTPR063DC1

① UL 508 Type E starters are assembled from a standard XTPR and a special incoming terminal line side adapter (XTPAXLSA or XTPAXLSAD).

② Select manual motor protectors by full load amperes. Maximum motor ratings (kW, hp) are for reference only.

③ In this range, calculate motor rating according to rated current. Specified values to NEC 430.6(A)(1).

Note: A UL 508 Type E self-protected manual combination starter (XTPR) consists of a manual motor protector (XTPR) and a UL listed line side adapter (e.g., XTPAXLSA). The Type E self-protected manual combination starter alone is a legitimate short-circuit protective device and disconnect means for the downstream motor, while the contactor has been added to provide remote operation of the motor circuit.

Circuit & Motor Protection

Manual Motor Protectors & Controllers

PRODUCT SELECTION

XT IEC Manual Motor Protectors — Accessories

Auxiliary Contacts

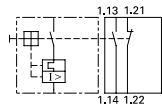
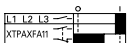
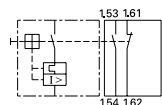
Contact Configuration	Contact Sequence	Screw Terminals	
		Pkg. Qty.	Catalog Number
Side-Mount			
1NO-1NC	 	5	XTPAXSA11
Front-Mount			
1NO-1NC	 	5	XTPAXFA11

IP65 Rotary Handle Mechanism ①②③

Description	Pkg. Qty.	Catalog Number
Complete Kits — Includes Handle, Shaft and Required Hardware		
 Rotary Handle Mechanism IP65 Black — For use on main switches to IEC / EN 60204.	1	XTPAXRHMB
Rotary Handle Mechanism IP65 Red / Yellow — For use on main switch with Emergency-Stop function to IEC / EN 60204.	1	XTPAXRHMR
Rotary Handle Mechanism IP65 Black — For use on main switches to IEC / EN 60204 where XTPR is mounted 90° from vertical.	1	XTPAXRHM90B
Rotary Handle Mechanism IP65 Red / Yellow — For use on main switch with Emergency-Stop function to IEC / EN 60204 where XTPR is mounted 90° from vertical.	1	XTPAXRHM90RY

- ① With ON/OFF switch position and "+" (tripped), lockable with 3 padlocks, 4 – 8 mm hasp. Can be locked in the OFF position, if required.
- ② Rotary handle mechanisms ship with door interlock disabled. See instruction publication with product for how to enable door interlock.
- ③ Not for use with XTPAXFAEM20 early-make front-mount auxiliary contact.

Shunt Release







Catalog Number — Screw Terminals	Pkg. Qty.
XTPAXSR120V60H	2
XTPAXSR240V60H	2
XTPAXSR480V60H	2
XTPAXSR24VDC	2

Undervoltage Release

Catalog Number — Screw Terminals	Pkg. Qty.
XTPAXUVR120V60H	2
XTPAXUVR240V60H	2
XTPAXUVR480V60H	2

XT IEC Manual Motor Protectors — Accessories

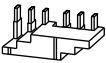
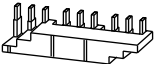
Three-Phase Commoning Links ①

	For Use with...	Qty MMP	Length of Link (mm)	Unit Width (mm)	Pkg Qty.	Catalog Number
Frame B						
	MMP With No Side-Mounted Auxiliaries or Voltage Releases	2	90	45	10	XTPAXCLKA2
		3	135	45	10	XTPAXCLKA3
		4	180	45	10	XTPAXCLKA4
		5	225	45	10	XTPAXCLKA5
Frame D						
	MMP With No Side-Mounted Auxiliaries or Voltage Releases	2	110	55	1	XTPAXCLKA2D
		3	165	55	1	XTPAXCLKA3D
		4	220	55	1	XTPAXCLKA4D



① Protected against accidental contact. B-Frame short circuit proof $U_e = 690V$, $I_u = 63A$; D-Frame short circuit proof $U_e = 690V$, $I_u = 128A$. Frame B links can be combined by rotating mounting. Frame D links cannot be combined.

Incoming Terminal for Three-Phase Commoning Link ①

	For Use with...	Pkg Qty.	Catalog Number
	B-Frame XTPR, XTPB	5	XTPAXIT

① For three-phase commoning link, protected against accidental contact, $U_e = 690V$, $I_u = 63A$; for conductor cross-sections: 2.5 – 25 mm² stranded; 2.5 – 16 mm² flexible with ferrules, AWG 14-6.

Line-Side Adapter ①

	For Use with...	Pkg Qty.	Catalog Number
	B-Frame XTPR to Create a UL 508 Type E/F Manual Combination Starter	5	XTPAXLSA
	D-Frame XTPR to Create a UL 508 Type E/F Manual Combination Starter	1	XTPAXLSAD ②

① XTPAXLSA is for three-phase commoning link, finger- and back-of-hand proof, $U_e = 690V$, $I_u = 60A$; for conductor cross sections: 2.5 – 25 mm² stranded, 2.5 – 16 mm² flexible with ferrule, AWG 14-6.

② XTPAXLSAD cannot be combined with three-phase commoning links.

Circuit & Motor Protection

Manual Motor Protectors & Controllers

PRODUCT SELECTION

XT IEC Manual Motor Protectors — Accessories

Combination Connection Kits for Connection of XTPR MMP with XTCE Contactor

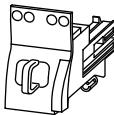
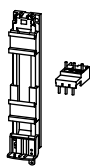
	For Use with...	Description	Std. Pack	Catalog Number
Non-Reversing Starters				
	XTPR...B + XTCE...B	Comprised of: <ul style="list-style-type: none"> • Mechanical connection element for XTPR...B and contactor • Main current wiring between XTPR...B and contactor in tool-less plug connection • Cable guidance Use contactor auxiliary switch XTCEXFAT_. Control cable guidance: max. 6 cables up to 2.5 mm ² external diameter or 4 cables up to 3.5 mm ² external diameter.	1	XTPAXTPCB
	XTPR...B + XTCE...C	Comprised of: <ul style="list-style-type: none"> • DIN-Rail adapter plate • Main current wiring between XTPR and contactor 	1	XTPAXTPCC
	XTPR...D + XTCE...D		1	XTPAXTPCD

Insulated Enclosures for Surface Mounting

	Degree of Protection	For Use with...	Description	Catalog Number
--	----------------------	-----------------	-------------	----------------

XTPB Pushbutton Manual Motor Protectors — North American Usage ①②

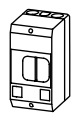
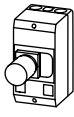
	IP65 NEMA 3R, 4X, 12, 13	XTPB MMP Only or with: XTPAXFA..., XTPBXFAEM20, XTPAXSA..., XTPAXUVR..., XTPAXSR..., XTPAXCL	With actuating diaphragm	XTPBXENAS65
	IP65 NEMA 3R, 4X, 12, 13	XTPB MMP Only or with: XTPAXFA..., XTPBXFAEM20, XTPAXUVR..., XTPAXSR..., XTPAXCL	With Emergency-Stop (E-Stop) pushbutton actuator, Red-Yellow	XTPBXENASE65

B-Frame (0.1 – 32A) XTPR Rotary Manual Motor Protectors — North American Usage ③

	IP55 NEMA 1, 12, 3R	B-Frame XTPR Only or with: XTPAXSA... and XTPAXFA..., XTPAXUVR... and XTPAXFA..., XTPAXSR... and XTPAXFA..., XTPAXCL	With red/yellow rotary handle for use as Emergency-Stop switch to VDE 0113	XTPAXENAS55RY
---	------------------------	--	--	---------------

D-Frame (10 – 65A) XTPR Rotary Manual Motor Protectors ④⑤

	IP65 NEMA 1, 12, 3R, 4X	D-Frame XTPR Only or with: XTPAXFA..., XTPAXFAEM20, XTPAXSA..., XTPAXSATR..., XTPAXUVR..., XTPAXSR..., XTPAXCL	With red/yellow rotary handle for use as Emergency-Stop switches to IEC / EN 60204	XTPAXENCSD65RY
---	----------------------------	--	--	----------------

① Built-in terminal for PE(N).

② North American enclosures come with conduit adapters for use with 1/2" NPT.

③ Built-in N and PE terminal, lower part without knockouts.

④ Integrated terminal for PE(N) connection.

⑤ % Metric knockouts:

Top ÷ bottom: M25/M32

In backplate: M25/M32

Control cable entry: M20

Circuit & Motor Protection

Manual Motor Protectors & Controllers

CATALOG SELECTION

XT IEC Combination Motor Controllers — Catalog Numbering System

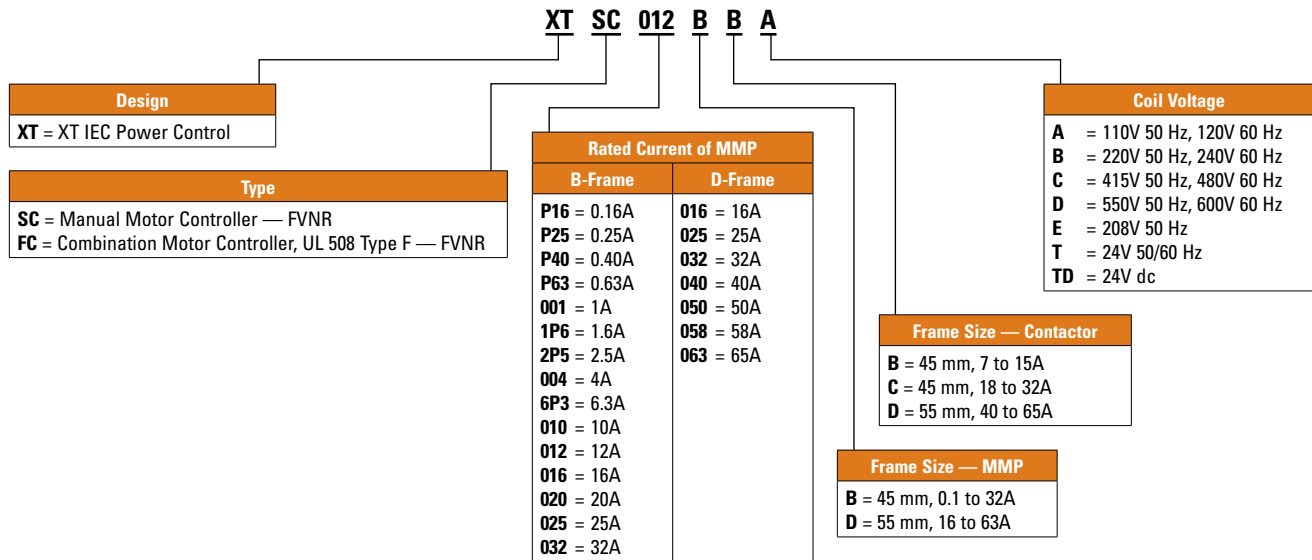

Circuit & Motor Protection

Manual Motor Protectors & Controllers

PRODUCT SELECTION

XTIEC Manual and Combination Motor Controllers

- ON/OFF rotary handle with lockout provision
- Class 10 overload protection
- Adjustment dial for setting motor FLA
- Built-in surge suppression on dc coils as standard
- Assembled manual motor controllers consist of manual motor protector, contactor, connector kit and 1NO-1NC auxiliary contact for MMP
- Assembled combination motor controllers consist of manual motor protector, contactor, connector kit, 1NO-1NC auxiliary contact for MMP and line side adapter
- Combination motor controllers are UL 508 Type F rated, and provide the following functions in a single device
 - Disconnect
 - Short circuit protection
 - Motor overload protection
 - Motor controller



XTSC Manual Motor Controllers (MMC) / Starter Combinations

Factory Assembled Motor Protective Device with Thermal and Magnetic Trip + Contactor										
FLA Adjustment Range (Amps) ①	Short-Circuit Release — I _m (Amps)	Maximum Motor Ratings — P ②								Assembled Manual Motor Controller ③
		Maximum Motor kW Rating AC-3 — P (kW)				Maximum hp Rating — P (hp)				
		Three-Phase				Three-Phase				Non-Reversing
		220 – 240V	380 – 415V	500V	660 – 690V	200V	240V	480V	600V	Catalog Number

Frame B MMP + Frame B Contactor

0.1 – 0.16	3.2	—	—	—	0.06	④	④	1/2	1/2	XTSC016BB_
0.16 – 0.25	3.5	—	0.06	0.06	0.12	④	④	1/2	1/2	XTSC025BB_
0.25 – 0.4	5.6	0.06	0.09	0.12	0.18	④	④	1/2	1/2	XTSC040BB_
0.4 – 0.63	8.82	0.09	0.18	0.25	0.25	④	④	1/2	1/2	XTSC063BB_
0.63 – 1	14	0.12	0.25	0.37	0.55	④	④	1/2	1/2	XTSC001BB_
1 – 1.6	22.4	0.25	0.55	0.75	1.1	④	④	3/4	1	XTSC1P6BB_
1.6 – 2.5	35	0.37	0.75	1.1	1.5	1/2	1/2	1	1-1/2	XTSC2P5BB_
2.5 – 4	56	0.75	1.5	2.2	3	1	1	2	3	XTSC004BB_
4 – 6.3	88.2	1.1	2.2	3	4	1-1/2	1-1/2	3	5	XTSC6P3BB_
6.3 – 10	140	2.2	4	4	7.5	3	3	7-1/2	10	XTSC010BB_
8 – 12	168	3	5.5	5.5	11	3	3	7-1/2	10	XTSC012BB_
10 – 16	224	4	7.5	9	12.5	3	3	10	10	XTSC016BB_

Frame B MMP + Frame C Contactor

10 – 16	224	4	7.5	9	12.5	3	3	10	10	XTSC016BC_
16 – 20	280	5.5	9	12.5	15	5	5	10	15	XTSC020BC_
20 – 25	350	5.5	11	15	22	5	7-1/2	15	20	XTSC025BC_
25 – 32	448	7.5	15	22	30	7-1/2	10	20	25	XTSC032BC_

Frame D MMP + Frame C Contactor

10 – 16	224	4	7.5	9	12.5	3	5	10	15	XTSC016DC_
16 – 25	350	5.5	12.5	12.5	22	7-1/2	7-1/2	20	25	XTSC025DC_
25 – 32	448	7.5	15	17.5	22	10	10	25	30	XTSC032DC_

Frame D MMP + Frame D Contactor

32 – 40	560	11	20	22	30	10	—	30	30	XTSC040DD_
40 – 50	700	14	25	30	45	15	15	30	40	XTSC050DD_
50 – 58	812	17	30	37	55	—	—	40	—	XTSC058DD_
55 – 65	882	18.5	34	37	55	—	—	40	—	XTSC063DD_

① Overload release — I_r

② Select manual motor protectors by full load amperes. Maximum motor ratings (kW, hp) are for reference only.

③ Underscore (_) indicates magnet coil suffix required. See Page 51.

④ In this range, calculate motor rating according to rated current. Specified values to NEC 430.6(A)(1).

Note: The assembled Manual Motor Controller (MMC) consists of an XTPR Manual Motor Protector (MMP) and an XTCE contactor. For Frame B MMP + Frame B Contactor assemblies, the XTSC can be mounted directly on DIN-Rail without an adapter. The contactors are supported mechanically with a mechanical connection element (included in XTPAXTPCB). For 16A and above, the assembly is mounted via a DIN-Rail Adapter Plate (XTPAXTPCPC, XTPAXTPCPD) and the electrical connection is made with electrical contact modules (XTPAXECMC, XTPAXECMD), both included in XTPAXTPCC and XTPAXTPCD. Service Factor Settings: Setting I_r of current scale in dependence of load factor:
SF = 1.15 — I_r = 1 x I_n mot
SF = 1 — I_r = 0.9 x I_n mot

XTIEC Manual and Combination Motor Controllers

XTFC Combination Motor Controllers (CMC), UL508 Type F

Factory Assembled Motor Protective Device with Thermal and Magnetic Trip + Contactor + Required Line Side Adapter										
FLA Adjustment Range (Amps) ①	Short-Circuit Release — I _{rm} (Amps)	Maximum Motor Ratings ②								Assembled Combination Motor Controller ③
		Maximum Motor kW Rating AC-3 — P (kW)				Maximum hp Rating — P (hp)				
		Three-Phase				Three-Phase				Non-reversing
		220 – 240V	380 – 415V	500V	660 – 690V	200V	240V	480V	600V	Catalog Number

Frame B MMP + Frame B Contactor

0.1 – 0.16	2.2	—	—	—	0.06	④	④	1/2	1/2	XTFCP16BB_
0.16 – 0.25	3.5	—	0.06	0.06	0.12	④	④	1/2	1/2	XTFCP25BB_
0.25 – 0.4	5.6	0.06	0.09	0.12	0.18	④	④	1/2	1/2	XTFCP40BB_
0.4 – 0.63	8.82	0.09	0.18	0.25	0.25	④	④	1/2	1/2	XTFCP63BB_
0.63 – 1	14	0.12	0.25	0.37	0.55	④	④	1/2	1/2	XTFC001BB_
1 – 1.6	22.4	0.25	0.55	0.75	1.1	④	④	3/4	1	XTFC1P6BB_
1.6 – 2.5	35	0.37	0.75	1.1	1.5	1/2	1/2	1	1-1/2	XTFC2P5BB_
2.5 – 4	56	0.75	1.5	2.2	3	1	1	2	3	XTFC004BB_
4 – 6.3	88.2	1.1	2.2	3	4	1-1/2	1-1/2	3	5	XTFC6P3BB_
6.3 – 10	140	2.2	4	4	7.5	3	3	7-1/2	10	XTFC010BB_
8 – 12	168	3	5.5	5.5	11	3	3	7-1/2	—	XTFC012BB_
10 – 16	224	4	7.5	9	12.5	3	5	10	—	XTFC016BB_

Frame B MMP + Frame C Contactor

10 – 16	224	4	7.5	9	12.5	3	5	10	—	XTFC016BC_
16 – 20	280	5.5	9	12.5	15	5	5	—	—	XTFC020BC_
20 – 25	350	5.5	11	15	22	5	7-1/2	15	—	XTFC025BC_
25 – 32	448	7.5	15	22	30	7-1/2	10	20	—	XTFC032BC_

Frame D MMP + Frame C Contactor

10 – 16	224	4	7.5	9	12.5	3	5	10	10	XTFC016DC_
16 – 25	350	5.5	12.5	12.5	22	7-1/2	7-1/2	20	25	XTFC025DC_
25 – 32	448	7.5	15	17.5	22	10	10	25	30	XTFC032DC_

Frame D MMP + Frame D Contactor

32 – 40	560	11	20	22	30	10	10	30	40	XTFC040DD_
40 – 50	700	14	25	30	45	10	15	30	—	XTFC050DD_
50 – 58	812	17	30	37	55	15	15	40	—	XTFC058DD_
55 – 65	882	18.5	34	37	55	15	15	40	—	XTFC063DD_

① Overload release — I_r

② Select combination motor controllers by full load amperes. Maximum motor ratings (kW, hp) are for reference only.

③ Underscore (_) indicates magnet coil suffix required. See table to the right.

④ In this range, calculate motor rating according to rated current. Specified values to NEC 430.6(A)(1).

Note: The assembled Combination Motor Controller (CMC) consists of an XTPR Manual Motor Protector (MMP) and an XTCE contactor and a required Line Side Adapter. For Frame B MMP + Frame B Contactor assemblies, the XTFC and XTFR can be mounted directly on DIN-Rail without an adapter. The contactors are supported mechanically with a mechanical connection element (included in XTPAXTPCB, XTPAXRPCRB). For 16A and above, the assembly is mounted via a DIN-Rail Adapter Plate (XTPAXTPCPC, XTPAXTPCPD) and the electrical connection is made with electrical contact modules (XTPAXECMC, XTPAXECMD), both included in XTPAXTPCC and XTPAXTPCD.

Service Factor Settings: Setting I_r of current scale in dependence of load factor:

$$SF = 1.15 \rightarrow I_r = 1 \times I_n \text{ mot}$$

$$SF = 1 \rightarrow I_r = 0.9 \times I_n \text{ mot}$$

Magnet Coil Suffixes

Coil Voltage	Suffix Code
110V 50 Hz, 120V 60 Hz	A
220V 50 Hz, 240V 60 Hz	B
24V 50/60 Hz	T
24V dc	TD ①
415V 50 Hz, 480V 60 Hz	C
550V 50 Hz, 600V 60 Hz	D
208V 60 Hz	E

① With dc Operation: Integrated diode-resistor combination, coil rating 2.6W.

Providing Essential Isolation



Powering Business Worldwide





- Arc quenching quick-make quick-break disconnects for galvanic isolation
- Fusible and non-fusible disconnects with rotary and pistol handle options
- Complete switch door mount options for UL 98 and UL 508 offerings

Circuit & Motor Protection

Rotary Disconnect Switches

PRODUCT OVERVIEW

Rotary Disconnect Switches Product Overview

					
Description	C362 (M Frame)	C362 (R Frame)	C362 (W Frame)	C362 (C Frame)	C362 (V & S Frame)
Page	Page 55	Page 55	Page 55	Page 56	Page 56
Current Rating	16A – 30A	30A – 60A	60A – 125A	30A	60A – 1200A
Non-Fusible	X	X	X	X	X
Fusible	—	—	—	—	—
Open Device	X	X	X	X	X
Enclosed Device	—	—	—	—	—
Customized Enclosed Product Available ①	X	X	X	X	X

Standards

UL 508	X	X ②	X ②	—	—
UL 98	—	—	—	—	X
UL 489	—	—	—	X	—
Clear On / Off Indication	X	X	X	X	X
Padlockable in the Off Position	X	X	X	X	X
Visible Blade Indication	—	—	—	X	X
Toggle Operation Available	—	30A & 40A	60A – 125A	—	—
Electrical Endurance (operation cycles)	6,000	6,000	6,000	6,000	③
Mechanical Endurance (operation cycles)	6,000	6,000	6,000	10,000	④
Fuse Type (if applicable)	RK5	RK5	RK5	CC/J	J (thru 600A); L (800A+)
Short Circuit Rating	5 kA	10 kA	10 kA	50 kA	200 kA (J); 100 kA (L)
Terminal Lugs (wire size / wire type)	#16 – #10/Cu	#14 – #8/Cu	#14 – #3/Cu	#14 – #10/Cu #14 – #10/Cu	⑤
Direct Handle Operation	X	X	X	—	—
Through-the-Door Operation	X	X	X	X	X
Full Range of Handles & Shafts	Pages 59 – 60	Pages 59 – 60	Pages 59 – 60	Page 60	Page 60
Accessories Available	Page 58	Page 58	Page 58	Page 59	Page 59

① Contact the Flex Center (1-888-329-9272).

② Suitable for use as a motor disconnect (30A – 100A only).

③ 6,000 (60A – 200A); 1,000 (400A – 600A); 500 (800A – 1200A).

④ 10,000 (60A – 100A); 8,000 (200A); 6,000 (400A – 600A); 3,500 (800A – 1200A).





⑤ #10 – #3/Cu (60A); #10 – 2/0/Cu (100A); #6 – 3/0/Cu (200A); #2 – 600MCM (400A – 1200A).

Circuit & Motor Protection

Rotary Disconnect Switches

PRODUCT OVERVIEW

Rotary Disconnect Switches Product Overview

				
Description	C363 (C Frame)	C363 (V & F Frame)	DR	SDR
Page	Page 56	Page 56	Page 57	Page 57
Current Rating	30A	30A – 800A	16A – 125A	30A & 60A
Non-Fusible	—	—	X	X
Fusible	X	X	—	—
Open Device	X	X	—	—
Enclosed Device	—	—	X	X
Customized Enclosed Product Available ①	X	X	X	—

Standards

UL 508	—	—	X	X
UL 98	—	X	—	—
UL 489	X	—	—	—
Clear On / Off Indication	X	X	X	X
Padlockable in the Off Position	X	X	X	X
Visible Blade Indication	—	—	—	—
Toggle Operation Available	—	—	—	—
Electrical Endurance (operation cycles)	6,000	②	6,000	6,000
Mechanical Endurance (operation cycles)	10,000	③	6,000	6,000
Fuse Type (if applicable)	CC/J	CC (30A); J (30 – 600A); L (800A)	RK5	RK5
Short Circuit Rating	50 kA	65 kA (CC); 200 kA (J); 100 kA (L)	⑤	⑥
Terminal Lugs (wire size / wire type)	#10 – #14/Cu	④	⑦	⑧
Direct Handle Operation	—	—	—	X
Through-the-Door Operation	X	X	X	—
Full Range of Handles & Shafts	Pages 59 – 60	Page 60	—	—
Accessories Available	Page 58	Page 58	Page 58	Page 58 ⑨

① Contact the Flex Center (1-888-329-9272).

② 6,000 (60A – 200A); 1,000 (400A – 600A); 500 (800A – 1200A).

③ 10,000 (60A – 100A); 8,000 (200A); 6,000 (400A – 600A); 3,500 (800A – 1200A).

④ #10 – #3/Cu (60A); #10 – 2/0/Cu (100A); #6 – 3/0/Cu (200A); #2 – 600MCM (400A – 1200A).

⑤ 5kA (16 – 25A); 10kA (30A – 125A).

⑥ 5kA (30A); 10kA (60A).

⑦ #16 – #10/Cu (16A – 25A); #14 – #8/Cu (30A – 40A); #14 – #3/Cu (60A – 125A).

⑧ #16 – #10/Cu (30A); #14 – #8/Cu (60A).

⑨ 60A products do not accept auxiliary contacts due to enclosure size.

Open Rotary Disconnect Switches

- Compact design to minimize panel space requirements
- Suitable for equipment or machinery as motor disconnects or industrial control panel disconnects
- Seven frame sizes to cover 16 – 1200A, 600V applications
- Direct handle or front through-the-door operation
- Base mounting or DIN-Rail mounting
- Visible blade indication (non-fusible C- and V-Frames)



When ordering, specify:

- Catalog Number of switch (see Pages 55 – 56)
- Catalog Number of operating handle (see Pages 59 – 60)
- Catalog Number of required shaft (see Pages 59 – 60)
- Catalog Number of (optional) accessories (see Page 58)

Non-Fusible Switches — UL 508, UL 98 and UL 489 ①②③

Ampere Rating	Maximum 3-Phase Horsepower Rating		Catalog Number	Frame	UL Standard	Operation (Rotary / Toggle)	No. of Poles	Switch Mounting
	240V	480V						
16	2	7-1/2	C362NM16	M	UL 508	Rotary	3	Base (low end)
20	3	7-1/2	C362NM20	M	UL 508	Rotary	3	Base (low end)
25	5	10	C362NM25	M	UL 508	Rotary	3	Base (low end)
30	7-1/2	15	C362NM30	M	UL 508	Rotary	3	Base (low end)
30	7-1/2	15	C362NR30	R	UL 508	Rotary	3	Base / DIN-Rail (high end) ④
40	10	20	C362NR40	R	UL 508	Rotary	3	Base / DIN-Rail (high end) ④
60	15	30	C362NR60	R	UL 508	Rotary	3	Base / DIN-Rail (high end) ④
60	15	30	C362NW60	W	UL 508	Rotary	3	Base / DIN-Rail (high end) ④
80	20	40	C362NW80	W	UL 508	Rotary	3	Base / DIN-Rail (high end) ④
100	25	50	C362NW100	W	UL 508	Rotary	3	Base / DIN-Rail (high end) ④
125	25	50	C362NW125	W	UL 508	Rotary	3	Base / DIN-Rail (high end) ④
30	7-1/2	15	C362TR30	R	UL 508	Toggle	3	Base / DIN-Rail
40	10	20	C362TR40	R	UL 508	Toggle	3	Base / DIN-Rail
60	15	30	C362TW60	W	UL 508	Toggle	3	Base / DIN-Rail
80	20	40	C362TW80	W	UL 508	Toggle	3	Base / DIN-Rail
100	25	50	C362TW100	W	UL 508	Toggle	3	Base / DIN-Rail
125	25	50	C362TW125	W	UL 508	Toggle	3	Base / DIN-Rail
16	2	7-1/2	C362NM16D	M	UL 508	Rotary	3	Back or Door Mounted w/o Handle ⑤
20	3	7-1/2	C362NM20D	M	UL 508	Rotary	3	Back or Door Mounted w/o Handle ⑤
25	5	10	C362NM25D	M	UL 508	Rotary	3	Back or Door Mounted w/o Handle ⑤
30	7-1/2	15	C362NM30D	M	UL 508	Rotary	3	Back or Door Mounted w/o Handle ⑤
30	7-1/2	15	C462NR30	R	UL 508	Rotary & Toggle	4	Base / DIN-Rail
40	10	20	C462NR40	R	UL 508	Rotary & Toggle	4	Base / DIN-Rail
30	7-1/2	15	C462TR30	R	UL 508	Rotary & Toggle	4	Base / DIN-Rail
40	10	20	C462TR40	R	UL 508	Rotary & Toggle	4	Base / DIN-Rail

① Back / door mounting M Frame: Will need to order selector handle separately (see Accessories UL 508 Accessories — M-, R-, W-Frames); see Page 58.

① Back / door mounting R & W Frame: Will need to order door mounting kit and selector handle separately (see Accessories UL 508 Accessories — M-, R-, W-Frames); see Pages 58 – 60.

② Back / door mounting UL 98 switches cannot be back-of-door mounted.

① Can be door mounted using catalog number **CTRFC** (Page 58).

② Includes door mounting kit and 55 mm selector shaft.

Circuit & Motor Protection

Rotary Disconnect Switches

PRODUCT SELECTION

Open Rotary Disconnect Switches

Non-Fusible and Fusible Switches — UL 98 and UL 489

Ampere Rating	Maximum 3-Phase Horsepower Rating		Catalog Number	Frame	UL Standard	Operation (Rotary / Toggle)	No. of Poles	Switch Mounting
	240 V	480 V						

Non-Fusible Switches — UL 98 and UL 489 ①

30	7-1/2	15	C362UC30	C	UL 98 and UL 489	Rotary	3	Base / DIN-Rail
400	125	250	C362US400	S	UL 98 and UL 489	Rotary	3	Base Mounted
600	250	500	C362US600	S	UL 98 and UL 489	Rotary	3	Base Mounted
800	250	500	C362US800	S	UL 98 and UL 489	Rotary	3	Base Mounted
1000	250	500	C362US1000	S	UL 98 and UL 489	Rotary	3	Base Mounted
1200	250	500	C362US1200	S	UL 98 and UL 489	Rotary	3	Base Mounted
60	15	30	C362UV60	V	UL 98 and UL 489	Rotary	3	Base Mounted
100	30	60	C362UV100	V	UL 98 and UL 489	Rotary	3	Base Mounted
200	60	125	C362UV200	V	UL 98 and UL 489	Rotary	3	Base Mounted

Fusible Switches — UL 98 and UL 489 ②

30	7-1/2	15	C363UC30CT	C	UL 98 and UL 489	Rotary	3	Base / DIN-Rail
30	7-1/2	15	C363UC30JT	C	UL 98 and UL 489	Rotary	3	Base Mounted
30	7-1/2	15	C363UV30CT	V	UL 98 and UL 489	Rotary	3	Base Mounted
30	7-1/2	15	C363UV30JT	V	UL 98 and UL 489	Rotary	3	Base Mounted
60	15	30	C363UV60JT	V	UL 98 and UL 489	Rotary	3	Base Mounted
100	30	60	C363UV100JT	V	UL 98 and UL 489	Rotary	3	Base Mounted
200	60	125	C363UV200JT	V	UL 98 and UL 489	Rotary	3	Base Mounted
400	125	250	C363UV400JT	V	UL 98 and UL 489	Rotary	3	Base Mounted
30	7-1/2	15	C363UV30C	V	UL 98	Rotary	3	Base Mounted
30	7-1/2	15	C363UV30J	V	UL 98	Rotary	3	Base Mounted
60	15	30	C363UV60J	V	UL 98	Rotary	3	Base Mounted
100	30	60	C363UV100J	V	UL 98	Rotary	3	Base Mounted
200	60	125	C363UV200J	V	UL 98	Rotary	3	Base Mounted
400	125	250	C363UV400J	V	UL 98	Rotary	3	Base Mounted
600	250	500	C363UF600J	F	UL 98	Rotary	3	Base Mounted
800	250	500	C363UF800L	F	UL 98	Rotary	3	Base Mounted

① Back / door mounting UL 98 switches cannot be back-of-door mounted.

② "T" suffix denotes test position is provided. Test handle is required only if test function is required.

Circuit & Motor Protection

Rotary Disconnect Switches

PRODUCT SELECTION

Enclosed Rotary Disconnect Switches

- 16 – 125 amperes
- 600V, 3 – 4-pole, non-fusible devices
- Accepts auxiliary contacts
- Ground lug connection provided



Rotary Disconnect Switches

UL 508 Type Rated Enclosed Non-Fusible Rotary Disconnects ①

Ampere Rating	Maximum 3-Phase Horsepower Rating			Switch Frame Size	UL Standard	Number of Poles	Type 1 Enclosure Indoor	Type 12 ② Enclosure Dust-Tight / Rainproof	Type 4X Enclosure Corrosion-Resistant Stainless Steel	Type 4X Enclosure Corrosion-Resistant Non-Metallic
	240	480	600				Catalog Number	Catalog Number	Catalog Number	Catalog Number
16	2	7.5	7.5	M	UL 508	3	DR3016UG	DR3016UD	DR3016UW	DR3016UX
25	5	10	15	M	UL 508	3	DR3025UG	DR3025UD	DR3025UW	DR3025UX
30	7.5	15	25	R	UL 508	3	DR3030UG	DR3030UD	DR3030UW	DR3030UX
40	10	20	30	R	UL 508	3	DR3040UG	DR3040UD	DR3040UW	DR3040UX
60	15	30	40	W	UL 508	3	DR3060UG	DR3060UD	DR3060UW	DR3060UX
80	20	40	50	W	UL 508	3	DR3080UG	DR3080UD	DR3080UW	DR3080UX
100	25	50	60	W	UL 508	3	DR3100UG	DR3100UD	DR3100UW	DR3100UX
125	25	50	60	W	UL 508	3	DR3125UG	DR3125UD	DR3125UW	DR3125UX
16	2	7.5	7.5	M	UL 508	4	DR4016UG	DR4016UD	DR4016UW	DR4016UX
25	5	10	15	M	UL 508	4	DR4025UG	DR4025UD	DR4025UW	DR4025UX
30	7.5	15	25	R	UL 508	4	DR4030UG	DR4030UD	DR4030UW	DR4030UX
40	10	20	30	R	UL 508	4	DR4040UG	DR4040UD	DR4040UW	DR4040UX

① Auxiliary contacts can be found on Page 58.

② NEMA Type 12 enclosures (16 – 125 amperes) can be field modified to meet NEMA Type 3R rainproof requirements when a factory-provided drain hole is opened.

IP65 Rated Enclosed Non-Fusible Rotary Disconnects ①

Ampere Rating	Maximum 3-Phase Horsepower Rating			Switch Frame Size	UL Standard	Number of Poles	Color	IP65 Rated Enclosure Corrosion-Resistant Non-Metallic
	240	480	600					Catalog Number
30	7.5	15	25	M	UL 508	3	White w/ Black Selector Handle	SDR3030UIP65BW
30	7.5	15	25	M	UL 508	3	Yellow w/ Red Selector Handle	SDR3030UIP65RY
60	15	30	40	R	UL 508	3	White w/ Black Selector Handle	SDR3060UIP65BW
60	15	30	40	R	UL 508	3	Yellow w/ Red Selector Handle	SDR3060UIP65RY

① Auxiliary contacts can be found on Page 58.

Note: Contact the Flex Center (1-888-329-9272) for factory-installed accessories or other special modifications.

Circuit & Motor Protection

Rotary Disconnect Switches

PRODUCT SELECTION

Rotary Disconnect Switches — Accessories

UL 508, M-, R-, W-Frames

Description		Catalog Number
Base Mounted 4th Pole Module for M-Frame		CM16BP CM20BP CM25BP
Toggle Cover Plates	For use with C362TR30 & TR40 For use with C362TW60 — TW125 For use with C462TR30 & TR40	CRP3 CWP3 CRP4
Auxiliary Contacts Kit (holder and contact)	1NO/1NC 3-Pole M-Frame (base mounted) 1NO/1NC 3-Pole M-Frame (door mounted) 1NO 3-Pole R-Frame 1NO 3-Pole W-Frame 1NO 4-Pole R-Frame	CMAC CMACD CRAC3 ① CWAC3 ① CRAC4 ①
Auxiliary Contacts (additional contacts)	1NO 3-, 4-Pole R-, W-Frame 1NC 3-, 4-Pole R-, W-Frame	CRAB ① CRAA ①
Protective Earth Module M-Frame Back / Door Mounted Extension Support		CNMFP C362SS1
Door Mounting Kit R- and W-Frame Rotary Switches Includes Selector Shaft and Hardware / Adapter to Mount to Door		CTRFC

① The mechanism is reversed on these contacts.

UL 98, C-, S-, V-, F-Frames

Description		Catalog Number
Auxiliary Contact Holders	V-Frame (for 1-8) C-Frame (for 5-8) ① S-Frame (for 1-4)	CUVU CUCU CUSU
Auxiliary Contacts	1NO, Type U 1NC, Type U, C-, V-, S- & F-Frames	CUSAA CUSAB
	1NO/NC, Type S-, V-Frames 2NO/NC, Type S-, V-Frames	CUVAC CUVAD
	1NO/NC, Type ST for Fusible, V-Frame w/ Test 2NO/NC, Type ST for Fusible, V-Frame w/ Test 1NO/NC, Type MS, F-Frame 2NO/NC, Type MS, F-Frame	CUVXC CUVXD CUFAC CUVAD
Line-Side Terminal Shrouds for Non-Fusible V- and S-Frames ②	3-Pole, V-Frame (200A)	CUV200T
	3-Pole, for Non-Fusible S-Frame (400 – 600A)	CUS600T
	3-Pole, for Non-Fusible S-Frame (800 – 1200A)	CUS1200T
Terminal Shrouds for Fusible V- and F-Frames ③	3-Pole, for Fusible V-Frame (100A)	CUV100T
	3-Pole, V-Frame (200A)	CUV200T
	3-Pole, for Fusible V-Frame (400A)	CUV400T
	3-Pole, for Fusible F-Frame (600 & 800A)	CUF800T
Terminal Lugs for Non-Fusible and Fusible V-, S- and F-Frames, for Line or Load Side ④	1 Wire / Lug, Wire Size 12-2/0, for Fusible V-Frame (100A) ⑤	CUV100LN
	1 Wire / Lug, Wire Size #6-3/0, V-Frame (200A) ⑤	CUV200LN
	2 Wires / Lug, Wire Size 2-600, V-, S- & F-Frames (400 & 600A) ⑤	CUS600LN
	2 Wires / Lug, Wire Size 2-600, S- & F-Frames (800 – 1200A) ⑤	CUS1200LN
NFPA 79 Kit	Suitable for Use with V&S Switches	C362VSNFPA

① C-Frames hold 1 – 4 auxiliary contacts without holder.

② Load-side terminal shrouds provided as standard on all ratings. Line-side terminal shrouds standard on C- and V-Frames up through 100A.

③ Load-side terminal shrouds provided as standard on all ratings. Line-side terminal shrouds standard on fusible switches up through 60A.

④ Standard on fusible up through 60A and non-fusible up through 100A.

⑤ Kit of 6.

Circuit & Motor Protection

Rotary Disconnect Switches

PRODUCT SELECTION

Rotary Disconnect Switches — Accessories

Handles and Shafts

		Black Selector Handle				Red/Yellow Selector Handle				Selector Shafts	
NEMA Rating	Defeatable	Padlockable	Color	Operation	IEC Type	Dimensions		Catalog Number			
						Inches	mm				

Selector Handle for Type CSSA_ Shaft and M-, R- and W-Frames or CSCSA_ Shaft and C-Frames

1	No	No	Black	ON / OFF	IP54	①	—	CSBR5
1, 3R, 12	No	Yes	Red / Yellow	ON / OFF, I/O	IP65	—	—	CSYR6
1, 3R, 12	No	Yes	Black	ON / OFF, I/O	IP65	—	—	CSBR6

Rotary Switch Selector Shaft 5 x 5 mm (for selector handle and M-, R- and W-Frames)

	2.2	55	CSSA055
	4.3	110	CSSA110
	5.9	150	CSSA150
	7.1	180	CSSA180
	7.9	200	CSSA200
	11.8	305	CSSA300

Rotary Switch Selector Shaft 5 x 5 mm (for selector handle and C-Frames)

	4.7	120	CSCSA120
	7.9	200	CSCSA200
	11.8	300	CSCSA320
	15.7	400	CSCSA400

		Black Pistol Handle (Type D)				Red/Yellow Pistol Handle (Type D)				Type D Pistol Shafts	
NEMA Rating	Defeatable	Padlockable	Color	Operation	IEC Type	Dimensions		Catalog Number			
						Inches	mm				

Pistol Handle Type D (for use with CPDSA_ shafts and M-, R- and W-Frames)

1, 3R, 12	No	Yes	Black	ON / OFF, I/O	IP54	①	—	CPBR5N
1, 3R, 12	No	Yes	Red / Yellow	ON / OFF, I/O	IP54	—	—	CPYR5N
1, 3R, 12	Yes	Yes	Black	ON / OFF, I/O	IP54	—	—	CPBR5D
1, 3R, 12	Yes	Yes	Red / Yellow	ON / OFF, I/O	IP54	—	—	CPYR5D

Type D Shafts 5 x 5 mm (for use with Type D pistol handles and M-, R- and W-Frames)

	4.7	120	CPDSA120
	7.9	200	CPDSA200
	12.6	320	CPDSA320
	15.7	400	CPDSA400

Direct Handle M-Frame (for direct mounting — no separate shaft required)

1, 3R, 12	No	Yes	Black	ON / OFF	IP54	①	—	CNMBH
-----------	----	-----	-------	----------	------	---	---	--------------

Direct Handle R-, W-Frames (for direct mounting — no separate shaft required)

1, 3R, 12	No	Yes	Black	ON / OFF	IP54	a	—	CRRR3
1, 3R, 12	No	Yes	Black	ON / OFF	IP54	—	—	CDRW3
1, 3R, 12	No	Yes	Black	ON / OFF	IP54	—	—	CDRR4

① Please refer to the Distribution Products Catalog (CA08101001E).

Circuit & Motor Protection

Rotary Disconnect Switches

PRODUCT SELECTION

Rotary Disconnect Switches — Accessories

Handles and Shafts (Continued)



Black Pistol Handle (Type G)



Red/Yellow Pistol Handle (Type G)



Type G Pistol Shafts

NEMA Rating	Defeatable	Padlockable	Color	Operation	IEC Type	Dimensions		Catalog Number
						Inches	mm	

Pistol Handle Type G (for use with M-, R-, W- and C-Frames with 5 x 5 shaft and V-Frame below 100A with 10 x 10 shaft)

1, 3R, 12	Yes	Yes	Black	ON / OFF, I/O	IP54	①	—	CPBR5
1, 3R, 12	Yes	Yes	Red / Yellow	ON / OFF, I/O	IP54	—	—	CPYR5
1, 3R, 12, 4, 4X	Yes	Yes	Black	ON / OFF, I/O	IP65	—	—	CPBW6
1, 3R, 12, 4, 4X	Yes	Yes	Red / Yellow	ON / OFF, I/O	IP65	—	—	CPYW6
1, 3R, 12, 4, 4X	Yes	Yes	Black	TEST / ON / OFF	IP65	①	—	CPBW6T
1, 3R, 12, 4, 4X	Yes	Yes	Red / Yellow	TEST / ON / OFF	IP65	—	—	CPYW6T

Long Pistol Handle Type GL (for use with V-Frame 100A and above with 10 x 10 shaft)

1, 3R, 12	Yes	Yes	Black	ON / OFF, I/O	IP54	①	—	CPBVR5
1, 3R, 12	Yes	Yes	Red / Yellow	ON / OFF, I/O	IP54	—	—	CPYVR5
1, 3R, 12, 4, 4X	Yes	Yes	Black	ON / OFF, I/O	IP65	—	—	CPBVW6
1, 3R, 12, 4, 4X	Yes	Yes	Red / Yellow	ON / OFF, I/O	IP65	—	—	CPYVW6
1, 3R, 12	Yes	Yes	Black	TEST / ON / OFF	IP65	—	—	CPBVW6T
1, 3R, 12	Yes	Yes	Red / Yellow	TEST / ON / OFF	IP65	—	—	CPYVW6T

Type G Shafts 5 x 5 mm (for use with Type G pistol handle and M-, R- and W-Frames)

	4.7	120	CPGSA120
	7.9	200	CPGSA200
	12.6	320	CPGSA320
	15.7	400	CPGSA400

Type G Shafts 5 x 5 mm (for use with Type G pistol handle and C-Frames)

	4.7	120	CPGCSA120
	7.9	200	CPGCSA200
	12.6	320	CPGCSA320
	15.7	400	CPGCSA400

Type G Shafts 10 x 10 mm (for use with Type G and GL pistol handles and V-Frames)

	7.9	200	CPGSB200
	12.6	320	CPGSB320
	15.7	400	CPGSB400



Pistol Handle (Type H)

NEMA Rating	Defeatable	Padlockable	Color	Operation	IEC Type	Dimensions		Catalog Number
						Inches	mm	

Pistol Handle Type H (for use with S-Frames with 15 x 15 shaft)

1, 3R, 4, 4X, 12	Yes	Yes	Black	ON / OFF, I/O	IP65	①	—	CPBSW6D
1, 3R, 4, 4X, 12	Yes	Yes	Red / Yellow	ON / OFF, I/O	IP65	—	—	CPYSW6D
1, 3R, 4, 4X, 12	No	Yes	Black	ON / OFF, I/O	IP65	—	—	CPBSW6N
1, 3R, 4, 4X, 12	No	Yes	Red / Yellow	ON / OFF, I/O	IP65	—	—	CPYSW6N

Pistol Handle Type H (for use with F-Frames with 15 x 15 shaft)

1, 3R, 4, 4X, 12	Yes	Yes	Black	ON / OFF, I/O	IP65	①	—	CPBFW6D
1, 3R, 4, 4X, 12	Yes	Yes	Red / Yellow	ON / OFF, I/O	IP65	—	—	CPYFW6D
1, 3R, 4, 4X, 12	No	Yes	Black	ON / OFF, I/O	IP65	—	—	CPBFW6N
1, 3R, 4, 4X, 12	No	Yes	Red / Yellow	ON / OFF, I/O	IP65	—	—	CPYFW6N

Type H Shafts 15 x 15 mm (for use with Type H pistol handles and S- and F-Frames)

	7.9	200	CPHSC200
	15.7	400	CPHSC400

① Please refer to the Distribution Products Catalog (CA08101001E).

Fewer Frames with Wider Ranges



Powering Business Worldwide

- Direct connect cost-effective thermal overload relays to protect your motors
- More accurate electronic overload relays react to phase loss fast
- Fewer frames covering a wider range of classes and protection with fewer parts
- Protect it right — fight premature motor failure with Motor Insight™

Circuit & Motor Protection

Overload Relays

PRODUCT OVERVIEW

Overload Relays Product Overview

				
Description	XT IEC Mini Overload Relays	XTOB, XTOT Thermal Overload Relays	C396 Electronic Overload Relays	Motor Insight Overload and Monitoring Relays
Page	Page 63	Page 64	Page 67	Page 69
Relay Type	Thermal Bi-Metallic	Thermal Bi-Metallic	Electronic	Electronic
Direct Connect to XT Contactor	Yes, XTMC	Yes, XTCE	Yes, XTCE	—
Separate Mount	—	Yes, Adapter	Yes	Yes
FLA Range	0.1 – 12A	0.1 – 630A	0.1 – 1500A	1 – 540A (with CTs)
FLA Max.:Min. Ratio	Approx. 1.5:1	Approx. 1.5:1	5:1	—
Motor Overload Protection	Yes	Yes	Yes	Yes
Underload Protection	—	—	—	Yes
Supply Protection	—	—	—	Yes
Enhanced Phase Loss Protection	—	—	Yes	Yes
Enhanced Phase Imbalance Protection	—	—	Yes	Yes
Trip Class	10A	10A	Selectable 5 / 10 / 20 / 30	5 – 30
Reset Type	Selectable Manual / Automatic	Selectable Manual / Automatic	Selectable Manual / Automatic	Selectable Manual / Automatic / Programmable / Remote
Communications with I/O	—	—	—	Yes (Modbus, DeviceNet, PROFIBUS)
Remote Display	—	—	—	Yes (NEMA 3R available)
Ground Fault	—	—	—	Yes
Alarm No Trip	—	—	—	Yes (voltage and ground faults)
Jam	—	—	Yes	Yes
Programmable Reset Timers	—	—	—	Yes
Programmable Reset Attempts	—	—	—	Yes
Current Monitoring	—	—	—	Yes
Voltage Monitoring	—	—	—	Yes
Power Monitoring	—	—	—	Yes
Thermal Capacity Monitoring	—	—	—	Yes
Motor Run Hours Monitoring	—	—	—	Yes

XT IEC Miniature Overload Relays — Catalog Numbering System

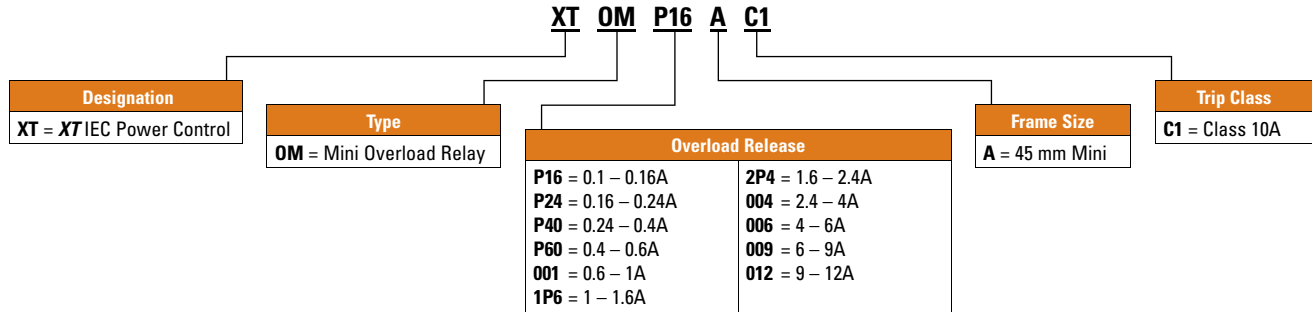

XT IEC Miniature Overload Relays

- Trip Class 10A
- Ambient temperature compensated -5° to 50°C (23° to 122°F)
- Selectable manual / automatic reset
- 1NO-1NC auxiliary contact as standard
- Direct mount with XTMC contactors



Mini Overload Relays ①②

Overload Release It	Trip Class	Contact Sequence	Contact Configuration	Short Circuit Protection (A)				Catalog Number
				Type 1 Coordination, gG / gL	Type 2 Coordination, gG / gL	Circuit Breaker	CEC/NEC Fuse	
0.1 – 0.16A 0.16 – 0.24A 0.24 – 0.4A 0.4 – 0.6A	10A		1NO-1NC	20	0.5	15	—	XTOMP16AC1
20				1	15	—	XTOMP24AC1	
20				2	15	—	XTOMP40AC1	
20				2	15	—	XTOMP60AC1	
0.6 – 1A 1 – 1.6A 1.6 – 2.4A	10A		1NO-1NC	20	4	15	3	XTOM001AC1
20				6	15	6	XTOM1P6AC1	
20				6	15	6	XTOM2P4AC1	
2.4 – 4A 4 – 6A 6 – 9A 9 – 12A	10A		1NO-1NC	20	10	15	15	XTOM004AC1
20				10	15	20	XTOM006AC1	
20				10	15	35	XTOM009AC1	
—				—	—	45	XTOM012AC1	

① Short-circuit protection: Observe the maximum permissible fuse of the contactor with direct device mounting. See MN03402002E for more information.

② When fitted directly to the contactor, a clearance of at least 5 mm is required between the overload relays.

Circuit & Motor Protection

Overload Relays

CATALOG SELECTION

XTOB, XTOT Thermal Overload Relays — Catalog Numbering System

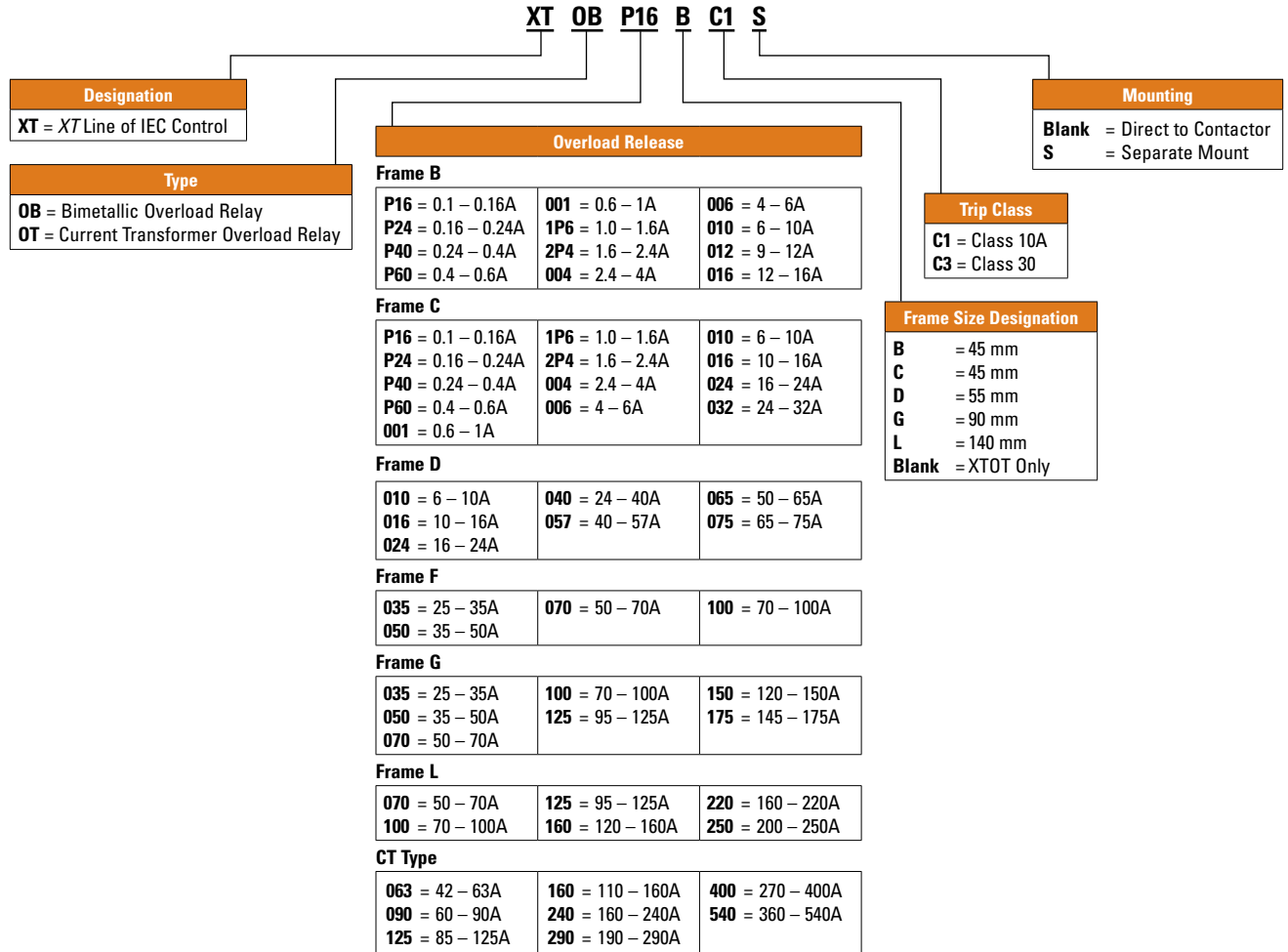

XTOB, XTOT Thermal Overload Relays

- Direct mount to XT contactors or separate mount
- Class 10A
- Up to 630A



Overload Relay

Overload Releases, I _n	Contact Sequence	Contact Configuration	For Use with Contactor Ampere Range	Short-Circuit Protection (A)		Catalog Number
				Maximum Circuit Breaker	CEC / NEC Fuse	

Frame B — Direct Mount to XTCE...B Contactor

0.1 – 0.16 0.16 – 0.24 0.24 – 0.4 0.4 – 0.6		1NO-1NC	7 – 15A	25	3	XTOBP16BC1
		1NO-1NC	7 – 15A	25	3	XTOBP24BC1
		1NO-1NC	7 – 15A	25	3	XTOBP40BC1
		1NO-1NC	7 – 15A	25	3	XTOBP60BC1
0.6 – 1 1 – 1.6 1.6 – 2.4 2.4 – 4		1NO-1NC	7 – 15A	25	3	XTOB001BC1
		1NO-1NC	7 – 15A	25	6	XTOB1P6BC1
		1NO-1NC	7 – 15A	25	6	XTOB2P4BC1
		1NO-1NC	7 – 15A	25	15	XTOB004BC1
4 – 6 6 – 10 9 – 12 12 – 16		1NO-1NC	7 – 15A	25	20	XTOB006BC1
		1NO-1NC	7 – 15A	25	35	XTOB010BC1
		1NO-1NC	9 – 15A	25	45	XTOB012BC1
		1NO-1NC	12 – 15A	30	45	XTOB016BC1

Frame C — Direct Mount to XTCE...C Contactor

0.6 – 1 1 – 1.6 1.6 – 2.4 2.4 – 4		1NO-1NC	18 – 32A	25	3	XTOB001CC1
		1NO-1NC	18 – 32A	25	6	XTOB1P6CC1
		1NO-1NC	18 – 32A	25	6	XTOB2P4CC1
		1NO-1NC	18 – 32A	25	15	XTOB004CC1
4 – 6 6 – 10 10 – 16 16 – 24 24 – 32		1NO-1NC	18 – 32A	25	20	XTOB006CC1
		1NO-1NC	18 – 32A	25	25	XTOB010CC1
		1NO-1NC	18 – 32A	30	25	XTOB016CC1
		1NO-1NC	18 – 32A	30	25	XTOB024CC1
		1NO-1NC	25 – 32A	30	25	XTOB032CC1

Frame D — Direct Mount to XTCE...D Contactor

6 – 10 10 – 16 16 – 24		1NO-1NC	40 – 72A	25	25	XTOB010DC1
		1NO-1NC	40 – 72A	25	25	XTOB016DC1
		1NO-1NC	40 – 72A	30	25	XTOB024DC1
24 – 40 40 – 57 50 – 65 65 – 75		1NO-1NC	40 – 72A	125	125	XTOB040DC1
		1NO-1NC	50 – 72A	150	150	XTOB057DC1
		1NO-1NC	65 – 72A	150	200	XTOB065DC1
		1NO-1NC	72A	150	200	XTOB075DC1

Frame F – G — Direct Mount to XTCE...F or XTCE...G Contactor

35 – 50 50 – 70 70 – 100		1NO-1NC	80 – 170A	150	200	XTOB050GC1
		1NO-1NC	80 – 170A	150	200	XTOB070GC1
		1NO-1NC	80 – 170A	400	400	XTOB100GC1
95 – 125 120 – 150 145 – 175		1NO-1NC	80 – 170A	500	400	XTOB125GC1
		1NO-1NC	80 – 170A	600	600	XTOB150GC1
		1NO-1NC	150 – 170A	600	600	XTOB175GC1

Note: Short circuit protection: Observe the maximum permissible fuse of the contactor with direct device mounting. See MN03402001E for more information on overload relays for Frame B – G.

Trip Class: 10A

Suitable for protection of EEx e-motors. EC prototype test certificate available upon request.

Observe manuals MN03402001E and MN03407001E. See Documentation — Manuals for Overload Monitoring of EEx e-motors.

Circuit & Motor Protection

Overload Relays

PRODUCT SELECTION

XTOB, XTOT Thermal Overload Relays

Overload Relay (Continued)

Overload Releases, I _r	Contact Sequence	Contact Configuration	For Use with Contactor Ampere Range	Short-Circuit Protection (A)		Catalog Number
				Maximum Circuit Breaker	CEC / NEC Fuse	
Frame F – G — Separate Mount						
35 – 50 50 – 70 70 – 100		1NO-1NC	80 – 170A	150	200	XTOB050GC1S
		1NO-1NC	80 – 170A	150	200	XTOB070GC1S
		1NO-1NC	80 – 170A	400	400	XTOB100GC1S
95 – 125 120 – 150 145 – 175		1NO-1NC	80 – 170A	500	400	XTOB125GC1S
		1NO-1NC	80 – 170A	600	600	XTOB150GC1S
		1NO-1NC	150 – 170A	600	600	XTOB175GC1S

Frame L — Direct Mount to XTC(EORS)...L or Separate Mount

50 – 70 70 – 100 95 – 125		1NO-1NC	185 - 250A	150	200	XTOB070LC1
		1NO-1NC	185 - 250A	400	400	XTOB100LC1
		1NO-1NC	185 - 250A	500	400	XTOB125LC1
120 – 160 160 – 220 200 – 250		1NO-1NC	185 - 250A	600	600	XTOB160LC1
		1NO-1NC	185 - 250A	800	800	XTOB220LC1
		1NO-1NC	225 - 250A	600	700	XTOB250LC1

Note: Short circuit protection: Observe the maximum permissible fuse of the contactor with direct device mounting. See MN03402001E for more information on overload relays for Frame B – G. Trip Class: 10A
Suitable for protection of EEx e-motors. EC prototype test certificate available upon request.
Observe manuals MN03402001E and MN03407001E. See Documentation — Manuals for Overload Monitoring of EEx e-motors.

Current Transformer Operated Overload Relay

Overload Releases, I _r	Contact Sequence	Contact Configuration	For Use with Contactor Ampere Range	Short-Circuit Protection (A)		Catalog Number
				Circuit Breaker	CEC / NEC Fuse	
Frame M – N — Separate Mount						
160 – 240 190 – 290 270 – 400 360 – 540 420 – 630		1NO-1NC	300 – 500A	600	700	XTOT240C3S
		1NO-1NC	300 – 500A	600	700	XTOT290C3S
		1NO-1NC	300 – 500A	1000	1000	XTOT400C3S
		1NO-1NC	500A	600	1000	XTOT540C3S
		1NO-1NC	630A	600	1000	XTOT630C3S

DIN-Rail or Panel-Mount Adapter, Frame C – D — Accessories ①

	For Use with...	Pkg. Qty.	Catalog Number
	XTOB...CC1	5	XTOBXDINC
	XTOB...DC1	2	XTOBXDIND

① Can be snap fitted on a top hat rail (DIN-Rail) or can be screw fitted.

Terminal Lug Kit – Set of (3) Lugs — Accessories

Description	For Use with...	Pkg. Qty.	Catalog Number
Set of 3 Lugs #6 AWG-350MCM	XTOB...LC1	1	XTOBXTLL

C396 Electronic Overload Relays — Catalog Numbering System

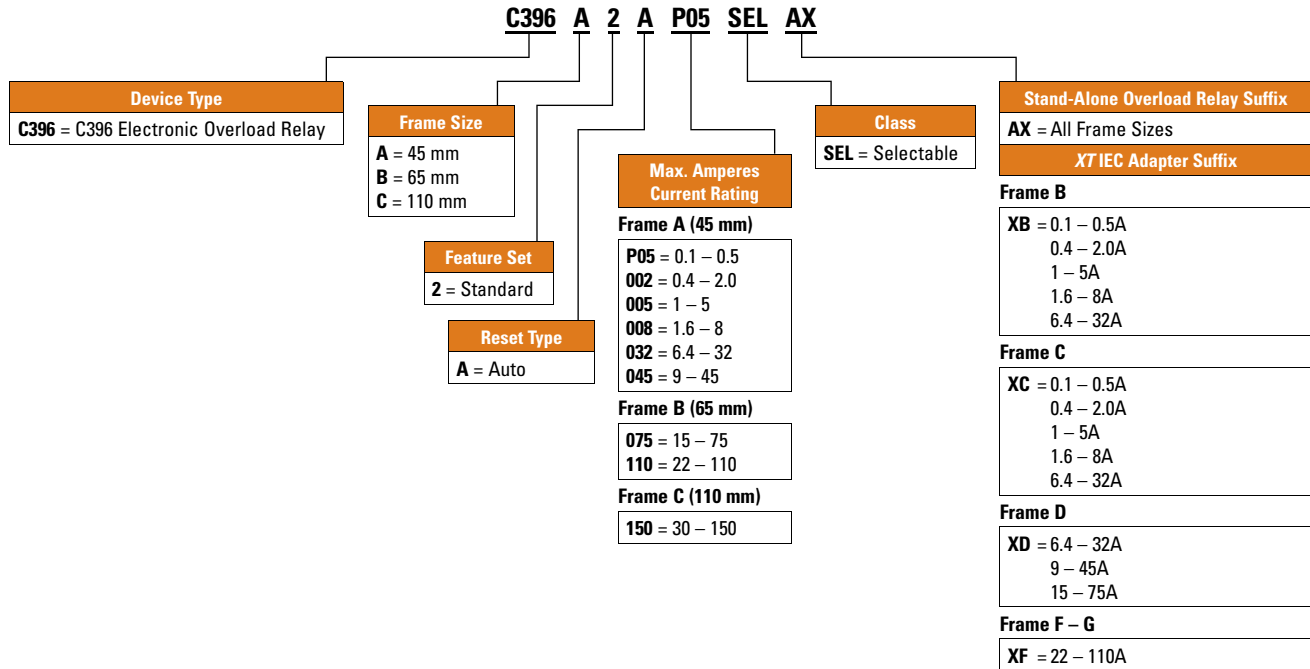

C396 Electronic Overload Relays

- Direct mount to XT contactors or separate mount
- Standard version: selectable trip class (5, 10, 20, 30) with selectable manual or auto reset
- Broad 5:1 FLA range
- Self-powered design, will accept ac voltages from 12 – 690V 50/60 Hz
- Electrically isolated 1NO-1NC contacts (Push-to-Test)
- FLA range of 0.1 – 1500 amps



C396 Overload for Integrated Use with XT IEC Contactors

FLA Range (Amps)	XT IEC Contactor Frame Size / Width	Catalog Number
Direct Mount to XTCE...B Contactor		
0.4 – 2.0	B / 45 mm	C396A2A002SELXB
1 – 5	B / 45 mm	C396A2A005SELXB
1.6 – 8	B / 45 mm	C396A2A008SELXB
6.4 – 32	B / 45 mm	C396A2A032SELXB
Direct Mount to XTCE...C Contactor		
1.6 – 8	C / 45 mm	C396A2A008SELXC
6.4 – 32	C / 45 mm	C396A2A032SELXC
Direct Mount to XTCE...D Contactor		
6.4 – 32	D / 55 mm	C396A2A032SELXD
9 – 45	D / 55 mm	C396A2A045SELXD
15 – 75	D / 55 mm	C396B2A075SELXD
Direct Mount to XTCE...F or XTCE...G Contactor		
22 – 110	F – G / 90 mm	C396B2A110SELXF

C396 Stand-Alone Overload Relay

FLA Range (Amps)	Description	Catalog Number
0.4 – 2.0 1 – 5 1.6 – 8 6.4 – 32 9 – 45	45 mm Frame Overload Relay ①	C396A2A002SELAX C396A2A005SELAX C396A2A008SELAX C396A2A032SELAX C396A2A045SELAX
15 – 75 22 – 110	65 mm Frame Overload Relay ①	C396B2A075SELAX C396B2A110SELAX
30 – 150	110 mm Frame Overload Relay ②	C396C2A150SELAX

① Overload comes with a panel / DIN-Rail mounting adapter assembled. No separate mounting adapter accessory offered.

② Panel-mount only! Overload comes with integrated pass-through holes for power wires. Bus Bar Kit (C396CBAR or C396CBARXT, see Page 68) and Lug Kit (C396CLUG) must be purchased separately if customer refers not to use pass-through capability.

Circuit & Motor Protection

Overload Relays

PRODUCT SELECTION





C396 Overload Relays

Current Transformer Kits for Use with Stand-Alone Overload Relay C396A2A005SELAX ①

FLA Range (Amps)	Description	Catalog Number
60 – 300	300: 5 Panel-mount CT kit with integrated, pass-through holes. Kit includes CT, bus bars, lugs and hardware to mount C396A2A005SELAX(not included).	C396CTK300
120 – 600	600: 5 Panel-mount CT kit with integrated, pass-through holes. Kit includes CT, bus bars, lugs and hardware to mount C396A2A005SELAX (not included).	C396CTK600
200 – 1000	1000: 5 Panel-mount CT kit with integrated, pass-through holes. Kit includes CT, bus bars, lugs and hardware to mount C396A2A005SELAX (not included).	C396CTK1000
300 – 1500	1500: 5 Panel-mount CT kit with integrated, pass-through holes. Kit includes CT, bus bars, lugs and hardware to mount C396A2A005SELAX (not included).	C396CTK1500

① C396A2A005SELAX is not included in the current transformer kits. This item must be ordered separately.

Accessories

	Description	Catalog Number
	Reset Bar Kit assembles to the top of the overload to increase reset area	C396ARST
	110 mm XT Bus Bar Kit ①	C396CBARXT
 C396ARST + C396RR_ _ _ _ _ Assembled to a C396 Overload Relay	Remote Reset 24V dc ②	C396RR024DC
	Remote Reset 24V ac ②	C396RR024AC
	Remote Reset 120V ac ②	C396RR120AC
	Remote Reset 240V ac ②	C396RR240AC
	Mechanical Reset with E22 Flush Pushbutton and Mechanical Push Rod ③ Plastic Black Bezel Chrome Bezel	E22PB6N29L E22P6N29L

① Bus bar kits do not include lugs. Order C396CLUG if lugs are needed (3 lugs per kit).

② Reset Bar Kit (C396ARST) required to use the Remote Reset modules.

③ The operator button is blue with the letters "RESET" printed in white. The push rod is 4.72" long and can be cut to the desired length. This kit can be used alone or in conjunction with the C396 Reset Bar Kit, C396ARST, to increase the size of the reset area on the overload.

Motor Insight Overload and Monitoring Relays — Catalog Numbering System

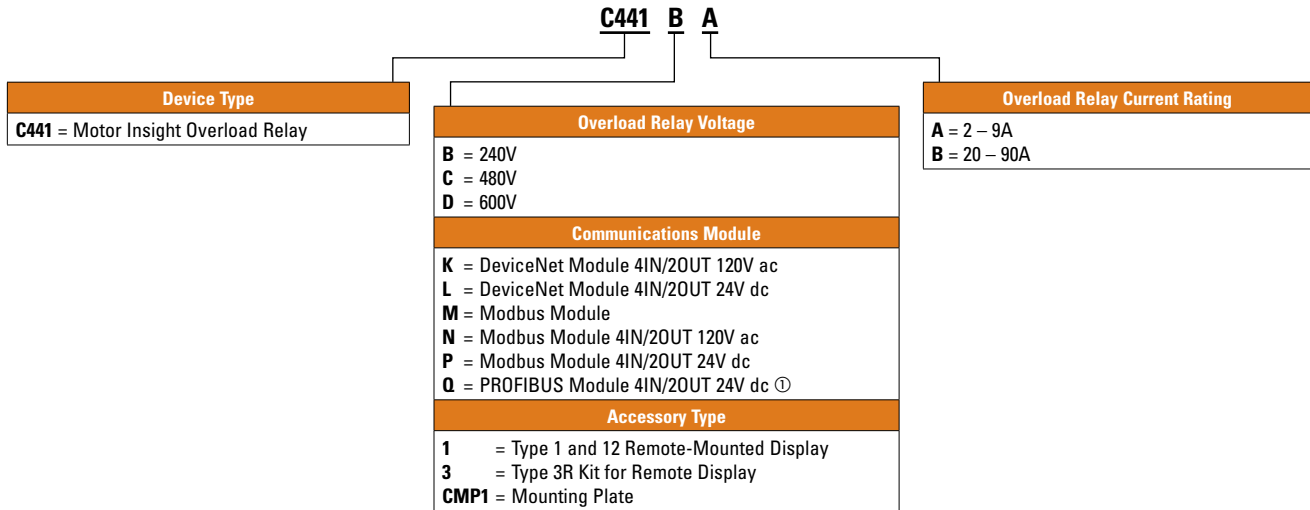

① PROFIBUS module with I/O will be available in 2nd Quarter 2009.

Circuit & Motor Protection

Overload Relays

PRODUCT SELECTION

Motor Insight™ Overload and Monitoring Relays

- Power, voltage and current monitoring, ground fault, flexible communications, motor, load and line protection in a single package
- Enhanced surge / sag withstand capacity ensures reliable operation
- Finger proof IP20 rated terminals provide extra safety by reducing shock hazard
- Adjustments to overload settings can be made without disconnecting power
- User Interface
 - Bright LED display
 - Intuitive and highly customizable parameter configuration
- Remote display allows for configuration without opening the panel, providing additional operator safety



Motor Insight

Voltage	Current Range	Catalog Number
240V ac (170 – 264)	2 – 9 Amps	C441BA
240V ac (170 – 264)	20 – 90 Amps	C441BB
480V ac (323 – 528)	2 – 9 Amps	C441CA
480V ac (323 – 528)	20 – 90 Amps	C441CB
600V ac (489 – 660)	2 – 9 Amps	C441DA
600V ac (489 – 660)	20 – 90 Amps	C441DB

Motor Insight CT Multiplier and Wire Wrap Schedule

Motor FLA	Number of Loops	Number of Conductors Through CT Primary	CT Multiplier Setting	Catalog Number ①
-----------	-----------------	---	-----------------------	------------------

Current Range: 20 – 90A

5 – 22.5	3	4	4	C441_B
6.67 – 30	2	3	3	
10 – 45	1	2	2	
20 – 90	0	1	1	

Current Range: 2 – 9A

1 – 5	1	2	2	C441_A
2 – 9	0	1	1	
60 – 135	0	1	150 – (150:5)	
120 – 270	0	1	300 – (300:5)	
240 – 540	0	1	600 – (600:5)	

① Underscore indicates operating voltage code required.
Operating Voltage Codes:

Code	Voltage
B	240V ac
C	480V ac
D	600V ac



Modbus Communication Module

Description	I/O	Catalog Number
Modbus Communication Module	None	C441M
Modbus Communication Module 4IN / 2OUT	120V ac	C441N
Modbus Communication Module 4IN / 2OUT	240V dc	C441P

DeviceNet Modules

Description	I/O	Catalog Number
DeviceNet Communication Module	120V ac	C441K
DeviceNet Communication Module	24V dc	C441L

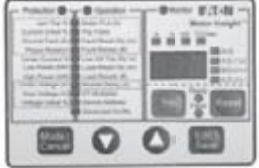
Motor Insight — Accessories

	Description	Catalog Number
	Remote Display Type 1	C4411
	Type 3R Kit for Remote Display (remote display not included)	C4413
	Adaptive Mounting Plate	C441CMP1