

## Achieve Safety Control through Programming.



- Compact Safety Controller.
- The NE1A-SCPU01-V1 provides 16 built-in safety inputs and 8 built-in safety outputs.  
The NE1A-SCPU02 provides 40 built-in safety inputs and 8 built-in safety outputs.
- Reduced wiring with safety networks. Connect up to 32 Safety Terminals.
- Monitor the safety system from Standard Controllers across the network.
- ISO13849-1 (PLe) and IEC 61508 SIL3 certification.

## Ordering Information

### List of Models

Name	No. of I/O points			Model	Unit version
	Safety inputs	Test outputs	Safety outputs		
Safety Network Controllers	16	4	8	NE1A-SCPU01-V1	2.0
	40	8	8	NE1A-SCPU02	2.0

**Note:** The standard NE1A Controllers are equipped with spring-cage terminal blocks, but other screw terminal blocks are available if desired, e.g., to replace previous terminals. Refer to CIP Safety on DeviceNet Accessories.

## Specifications

### Certified Standards

Certification body	Standard
TÜV Rheinland	NFPA 79-2012
	EN ISO13849-1: 2008
	IEC61508 part 1-7: 2010
	IEC61131-2: 2007
	EN ISO13849-2: 2012
	EN61000-6-4: 2007
	EN61000-6-2: 2005
UL	EN60204-1: 2006
	EN ISO13850: 2006(EN418: 1992)
	ANSI RIA15.06-1999
	ANSI B11.19-2010
	UL508
	ANSI/ISA 12.12.01
	UL1998
UL	NFPA79
	IEC61508
	CSA22.2 No.142
	CSA22.2 No.213

### Specifications

Item	Model	NE1A-SCPU01-V1	NE1A-SCPU02
<b>Communications power supply voltage</b>		11 to 25 VDC supplied via communications connector	
<b>Internal circuit power supply voltage (V0) *1</b>		20.4 to 26.4 VDC (24 VDC -15%/+10%)	
<b>I/O power supply voltage (V1, V2) *1</b>		20.4 to 26.4 VDC (24 VDC -15%/+10%)	
<b>Current consumption</b>	<b>Communications power supply</b>	24 VDC, 15 mA	
	<b>Internal circuit power supply</b>	24 VDC, 230 mA	24 VDC, 280 mA
	<b>I/O power supply *2</b>	24 VDC, 40 mA (Input) 120 mA (Output)	24 VDC, 80 mA (Input) 150 mA (Output)
<b>Overvoltage category</b>		II	
<b>Noise immunity</b>		Conforms to IEC61131-2.	
<b>Vibration resistance</b>		10 to 57 Hz: 0.35 mm, 57 to 150 Hz: 50 m/s <sup>2</sup>	
<b>Shock resistance</b>		150 m/s <sup>2</sup> : 11 ms	
<b>Mounting method</b>		DIN Track (IEC 60715 TH35-7.5/TH35-15)	
<b>Ambient operating temperature</b>		-10 to 55°C	
<b>Ambient operating humidity</b>		10% to 95% (with no condensation)	
<b>Ambient storage temperature</b>		-40 to 70°C	
<b>Degree of protection</b>		IP20	
<b>Serial interface</b>		USB version 1.1	
<b>Weight</b>		460 g max.	690 g max.

- \*1. V0-G0: Internal control circuit  
 V1-G1 (G): For external input device, test output  
 V2-G2 (G): For external output device  
 The two ground terminals on the NE1A-SCPU02 are internally connected.
- \*2. Not including power consumption for external devices.

## Safety Input Specifications

<b>Input type</b>	Sinking inputs (PNP)
<b>ON voltage</b>	11 VDC min. between each terminal and ground
<b>OFF voltage</b>	5 VDC min. between each terminal and ground
<b>OFF current</b>	1 mA max.
<b>Input current</b>	4.5 mA

## Safety Output Specifications

<b>Output type</b>	Sourcing outputs (PNP)
<b>Rated output current</b>	0.5 A max./output
<b>ON residual voltage</b>	1.2 V max. between each output terminal and V2
<b>Leakage current</b>	0.1 mA max.

## Test Output Specifications

<b>Output type</b>	Sourcing outputs (PNP)
<b>Rated output current</b>	0.7 A max./output *
<b>ON residual voltage</b>	1.2 V max. between each output terminal and V1
<b>Leakage current</b>	0.1 mA max.

\*The maximum current for simultaneously ON outputs is 1.4 A.  
(T0 to T3: NE1A-SCPU01-V1, T0 to T7: NE1A-SCPU02)  
A 15 to 400-mA, 24-VDC external indicator can be connected to T3 and T7.

## DeviceNet Communications Specifications

<b>Communications protocol</b>	DeviceNet compliant														
<b>Connection form</b>	Multi-drop system and T-branch system can be combined (for trunk line and branch lines)														
<b>Communications speed</b>	500/250/125 kbps														
<b>Communications media</b>	Special cable, 5 conductors (2 for communications, 2 for power supply, 1 for shielding)														
<b>Communications distance</b>	<table border="1"> <thead> <tr> <th>Communications speed</th> <th>Max. network length</th> <th>Branch length</th> <th>Total branch length</th> </tr> </thead> <tbody> <tr> <td>500 kbps</td> <td>100 m max. (100 m max.)</td> <td rowspan="3">6 m max.</td> <td>39 m max.</td> </tr> <tr> <td>250 kbps</td> <td>250 m max. (100 m max.)</td> <td>78 m max.</td> </tr> <tr> <td>125 kbps</td> <td>500 m max. (100 m max.)</td> <td>156 m max.</td> </tr> </tbody> </table>	Communications speed	Max. network length	Branch length	Total branch length	500 kbps	100 m max. (100 m max.)	6 m max.	39 m max.	250 kbps	250 m max. (100 m max.)	78 m max.	125 kbps	500 m max. (100 m max.)	156 m max.
	Communications speed	Max. network length	Branch length	Total branch length											
	500 kbps	100 m max. (100 m max.)	6 m max.	39 m max.											
	250 kbps	250 m max. (100 m max.)		78 m max.											
125 kbps	500 m max. (100 m max.)	156 m max.													
<b>Note:</b> Figures in parentheses ( ) indicate values when a thin cable is used.															
<b>Communications power supply</b>	11 to 25 VDC														
<b>No. of connectable nodes</b>	63														
<b>Safety I/O communications (Pre-Ver. 1.0)</b>	Safety Master function <ul style="list-style-type: none"> <li>• Max. no. of connections: 16</li> <li>• Max. data size: Input 16 bytes or output 16 bytes (per connection)</li> <li>• Connection type: Single-cast, multi-cast</li> </ul> Safety Slave function <ul style="list-style-type: none"> <li>• Max. no. of connections: 4</li> <li>• Max. data size: Input 16 bytes or output 16 bytes (per connection)</li> <li>• Connection type: Single-cast, multi-cast</li> </ul>														
<b>Safety I/O communications (unit version 1.0 or later)</b>	Safety Master function <ul style="list-style-type: none"> <li>• Max. no. of connections: 32</li> <li>• Max. data size: Input 16 bytes or output 16 bytes (per connection)</li> <li>• Connection type: Single-cast, multi-cast</li> </ul> Safety Slave function <ul style="list-style-type: none"> <li>• Max. no. of connections: 4</li> <li>• Max. data size: Input 16 bytes or output 16 bytes (per connection)</li> <li>• Connection type: Single-cast, multi-cast</li> </ul>														
<b>Standard I/O communications (all unit versions)</b>	Standard Slave function <ul style="list-style-type: none"> <li>• Max. no. of connections: 2</li> <li>• Max. data size: Input 16 bytes or output 16 bytes (per connection)</li> <li>• Connection type: Poll, bit-strobe, COS, cyclic</li> </ul>														
<b>Message communications</b>	Max. message length: 552 bytes														

## Functions

### Function Blocks

NE1A-SCPU-series Controller support the following logic functions and function blocks. Support depends on the unit version.

#### Logic Functions

Name	Function list entry	Supporting unit versions
NOT	NOT	All
AND	AND	
OR	OR	
Exclusive OR	EXOR	
Exclusive NOR	EXNOR	
RS Flip-flop	RS-FF	1.0 or later
Comparator	Comparator	

#### Function Blocks

Name	Function list entry	Supporting unit versions
Reset	Reset	All
Restart	Restart	
Emergency Stop Monitoring	E-STOP	
Light Curtain Monitoring	Light Curtain Monitoring	
Safety Gate Monitoring	Safety Gate Monitoring	
Two-hand Controller	Two Hand Controller	
Off-Delay Timer	Off-Delay Timer	
On-Delay Timer	On-Delay Timer	
User Mode Switch Monitoring	User Mode Switch	
External Device Monitoring	EDM	
Routing	Routing	
Muting	Muting	
Enable Switch Monitoring	Enable Switch	
Pulse Generator	Pulse Generator	
Counter	Counter	
Multiconnector	Multi Connector	

# Internal Circuit Diagrams

## NE1A-SCPU01-V1

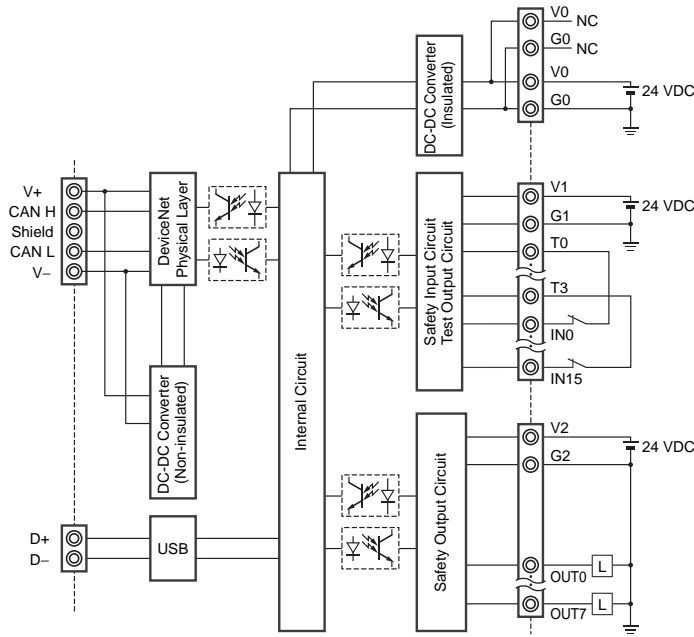

Terminal name	Description
V0	Power supply terminal for internal circuit The two V0 terminals are internally connected.
G0	Power supply terminal for internal circuit The two G0 terminals are internally connected.
V1	Power supply terminal for external input device and test output
G1	Power supply terminal for external input device and test output
V2	Power supply terminal for external output device
G2	Power supply terminal for external output device
IN0 to IN15	Safety input terminal
T0 to T3	Test output terminal Connected to IN0 to IN15 safety inputs. Each test output terminal outputs a different test pulse pattern. Terminal T3 also supports a current monitoring function for the output signal. Example: Muting lamp
OUT0 to OUT7	Safety output terminals

## NE1A-SCPU02

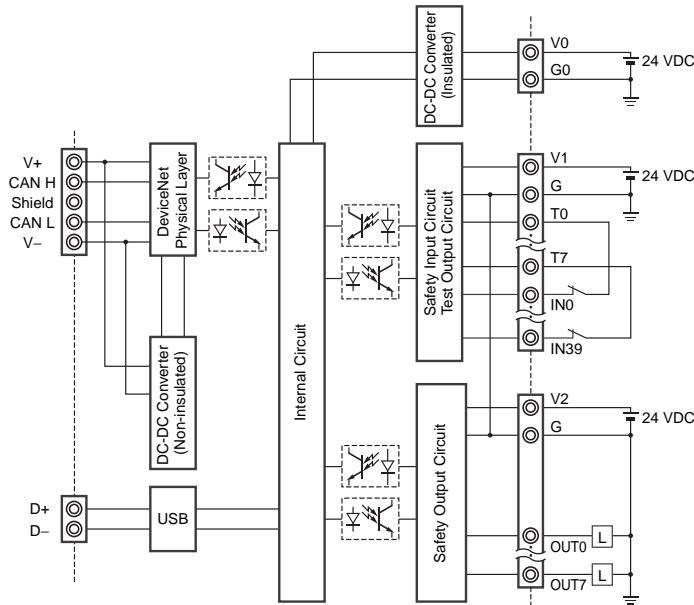

Terminal name	Description
V0	Power supply terminal for internal circuit The two V0 terminals are internally connected.
G0	Power supply terminal for internal circuit The two G0 terminals are internally connected.
V1	Power supply terminal for external input device and test output
G	Power supply terminal for external input device and test output
V2	Power supply terminal for external output device
G	Power supply terminal for external output device
IN0 to IN39	Safety input terminal
T0 to T3	Test output terminal Connected to IN0 to IN19 safety inputs. Each test output terminal outputs a different test pulse pattern. Terminal T3 also supports a current monitoring function for the output signal. Example: Muting lamp
T4 to T7	Test output terminal Connected to IN20 to IN39 safety inputs. Each test output terminal outputs a different test pulse pattern. Terminal T7 also supports a current monitoring function for the output signal. Example: Muting lamp
OUT0 to OUT7	Safety output terminals

Refer to the *CIP Safety on DeviceNet Safety Network Controllers Operation Manual* (Cat. No. Z906) for wiring examples.

Dimensions

NE1A-SCPU01-V1

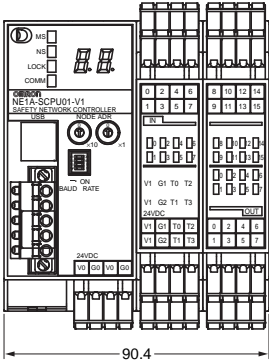

## Safety Precautions

Refer to the "Safety Precautions for All CIP Safety on DeviceNet Systems" for precautions.

Be sure to read the following user's manual for other details required for correct use of the Safety Network Controller.

CIP Safety on DeviceNet Safety Network Controller User's Manual (Cat. No. Z916)

### Functions Supported According to Unit Version

○: Supported, ---: Not supported

Model	NE1ASCPU01	NE1ASCPU01-V1	NE1ASCPU02
Unit version	Pre-Ver. 1.0	Unit version 1.0/2.0	Unit version 1.0/2.0
Logic processing functions			
Maximum program size (total number of function blocks)	128	254	254
New Function Blocks • RS flip-flop • Multiconnector • Muting • Enable Switch Monitoring • Pulse Generator • Counter • Comparator	---	○	○
Selecting a rising edge as the reset condition for Reset and Restart function blocks	---	○	○
Using local I/O status in logic programming	---	○	○
Using overall Unit status in logic programming	---	○	○
Program execution wait functions	---	○ (Unit version 2.0 or higher)	○ (Unit version 2.0 or higher)
I/O control functions			
Monitoring contact operation counter	---	○	○
Mounting total ON time monitor	---	○	○
DeviceNet communications functions			
Number of safety I/O connections for Safety Master	16	32	32
Selecting operating mode for safety I/O communications when communications errors occur	---	○	○
Attaching local output data to send data during slave operation	---	○	○
Attaching local I/O monitor data to send data during slave operation	---	○	○
Functions to communicate with devices existing on other networks (Off-Link connection)	---	○ (Unit version 2.0 or higher)	○ (Unit version 2.0 or higher)
System startup and error recovery functions			
Storing log of nonfatal errors in nonvolatile memory	---	○	○
Adding function block errors to error log	---	○	○
Ethernet/IP communications functions			
I/O communications	---	---	---
Message communications	---	---	---
Read/write of target I/O area	---	---	---
Routing between DeviceNet and EtherNet/IP			
I/O routing	---	---	---
Message routing	---	---	---
UDP/IP message communications functions			
Message communications by UDP/IP	---	---	---

## Unit Versions and Network Configurator Versions

Network Configurator version 2.0□ or higher must be used when using a NE1A-SCPU01-V1 or NE1A-SCPU02 Safety Logic Controller with unit version 2.0.

○ : Applicable, ×: Not applicable

Model	Network Configurator					
	Ver. 1.3□	Ver. 1.5□	Ver. 1.6□	Ver. 2.0□/2.1□	Ver.2.2□	Ver.3.3□
NE1A-SCPU01 Pre-Ver. 1.0	○	○	○	○	○	○
NE1A-SCPU01-V1 Unit version 1.0	×	×	○	○	○	○
NE1A-SCPU02 Unit version 1.0	×	×	○	○	○	○
NE1A-SCPU01-V1 Unit version 2.0	×	×	○(*1)	○	○	○
NE1A-SCPU02 Unit version 2.0	×	×	○(*1)	○	○	○

\*1: It can be used as unit version 1.0.

**Note: 1.** Users who use Network Configurator version 1.5□ or earlier can upgrade to version 1.6□ at no charge.

**2.** When using Network Configurator version 1.6□, there are no operational differences in the NE1A-SCPU01-V1 and NE1A-SCPU02.

## Terms and Conditions Agreement

### Read and understand this catalog.

Please read and understand this catalog before purchasing the products. Please consult your OMRON representative if you have any questions or comments.

### Warranties.

(a) Exclusive Warranty. Omron's exclusive warranty is that the Products will be free from defects in materials and workmanship for a period of twelve months from the date of sale by Omron (or such other period expressed in writing by Omron). Omron disclaims all other warranties, express or implied.

(b) Limitations. OMRON MAKES NO WARRANTY OR REPRESENTATION, EXPRESS OR IMPLIED, ABOUT NON-INFRINGEMENT, MERCHANTABILITY OR FITNESS FOR A PARTICULAR PURPOSE OF THE PRODUCTS. BUYER ACKNOWLEDGES THAT IT ALONE HAS DETERMINED THAT THE PRODUCTS WILL SUITABLY MEET THE REQUIREMENTS OF THEIR INTENDED USE.

Omron further disclaims all warranties and responsibility of any type for claims or expenses based on infringement by the Products or otherwise of any intellectual property right. (c) Buyer Remedy. Omron's sole obligation hereunder shall be, at Omron's election, to (i) replace (in the form originally shipped with Buyer responsible for labor charges for removal or replacement thereof) the non-complying Product, (ii) repair the non-complying Product, or (iii) repay or credit Buyer an amount equal to the purchase price of the non-complying Product; provided that in no event shall Omron be responsible for warranty, repair, indemnity or any other claims or expenses regarding the Products unless Omron's analysis confirms that the Products were properly handled, stored, installed and maintained and not subject to contamination, abuse, misuse or inappropriate modification. Return of any Products by Buyer must be approved in writing by Omron before shipment. Omron Companies shall not be liable for the suitability or unsuitability or the results from the use of Products in combination with any electrical or electronic components, circuits, system assemblies or any other materials or substances or environments. Any advice, recommendations or information given orally or in writing, are not to be construed as an amendment or addition to the above warranty.

See <http://www.omron.com/global/> or contact your Omron representative for published information.

### Limitation on Liability; Etc.

OMRON COMPANIES SHALL NOT BE LIABLE FOR SPECIAL, INDIRECT, INCIDENTAL, OR CONSEQUENTIAL DAMAGES, LOSS OF PROFITS OR PRODUCTION OR COMMERCIAL LOSS IN ANY WAY CONNECTED WITH THE PRODUCTS, WHETHER SUCH CLAIM IS BASED IN CONTRACT, WARRANTY, NEGLIGENCE OR STRICT LIABILITY.

Further, in no event shall liability of Omron Companies exceed the individual price of the Product on which liability is asserted.

### Suitability of Use.

Omron Companies shall not be responsible for conformity with any standards, codes or regulations which apply to the combination of the Product in the Buyer's application or use of the Product. At Buyer's request, Omron will provide applicable third party certification documents identifying ratings and limitations of use which apply to the Product. This information by itself is not sufficient for a complete determination of the suitability of the Product in combination with the end product, machine, system, or other application or use. Buyer shall be solely responsible for determining appropriateness of the particular Product with respect to Buyer's application, product or system. Buyer shall take application responsibility in all cases.

NEVER USE THE PRODUCT FOR AN APPLICATION INVOLVING SERIOUS RISK TO LIFE OR PROPERTY OR IN LARGE QUANTITIES WITHOUT ENSURING THAT THE SYSTEM AS A WHOLE HAS BEEN DESIGNED TO ADDRESS THE RISKS, AND THAT THE OMRON PRODUCT(S) IS PROPERLY RATED AND INSTALLED FOR THE INTENDED USE WITHIN THE OVERALL EQUIPMENT OR SYSTEM.

### Programmable Products.

Omron Companies shall not be responsible for the user's programming of a programmable Product, or any consequence thereof.

### Performance Data.

Data presented in Omron Company websites, catalogs and other materials is provided as a guide for the user in determining suitability and does not constitute a warranty. It may represent the result of Omron's test conditions, and the user must correlate it to actual application requirements. Actual performance is subject to the Omron's Warranty and Limitations of Liability.

### Change in Specifications.

Product specifications and accessories may be changed at any time based on improvements and other reasons. It is our practice to change part numbers when published ratings or features are changed, or when significant construction changes are made. However, some specifications of the Product may be changed without any notice. When in doubt, special part numbers may be assigned to fix or establish key specifications for your application. Please consult with your Omron's representative at any time to confirm actual specifications of purchased Product.

### Errors and Omissions.

Information presented by Omron Companies has been checked and is believed to be accurate; however, no responsibility is assumed for clerical, typographical or proofreading errors or omissions.