

Industrial Lighting

Section L

Advanced technology, expert support, global certifications, and an unmatched selection of proven solutions combine to deliver superior illumination, increased safety, and the lowest possible cost of ownership.

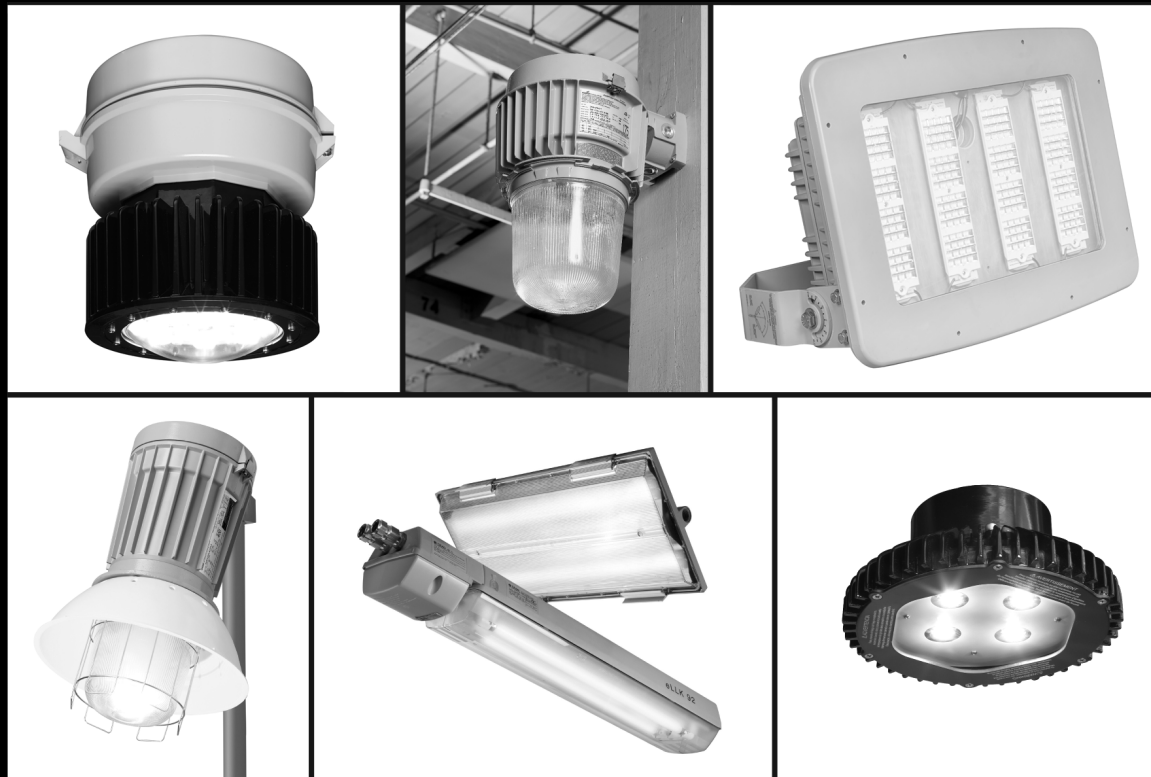

New Products in the Lighting Product Line

- Hazard•Gard® EVLL Series Explosionproof LED Luminaires
- Hazard•Gard® LPL Series Explosionproof LED Luminaires
- LL48 Linear LED Luminaires
- Champ® FMV LED Series Floodlight Fixtures
- Champ® Pro PVM Series
- Champ® Pro PFM Series
- Champ® Pro PFM Series 25L and 50L LED Floodlights
- Vaporgard™ Pro P2L Series
- Industrial High Bay LED Series Luminaires
- Endure™ LED Wall Pack

Section

- 2L
- 2L
- 2L
- 2L, 6L
- 2L
- 2L, 6L
- 2L, 6L
- 2L
- 2L
- 2L

Notable changes to the Lighting section of this catalog

- Section 3L now contains both hazardous/non-hazardous HID luminaires and induction lighting (previously 3L & 5L)

L Industrial Lighting

Table of Contents

Section L of the Eaton's Crouse-Hinds Catalog contains information on industrial lighting.

Product details on individual luminaires are given in ten separate sections, as noted below.

Considerations for Selection

Preceding the ten product sections is a Selector Guide. Included in this section is information on:

- A selection of the appropriate light source for a given application
- A Quick Selector Guide of the luminaires that are designed and approved to meet the various environmental requirements of the National Electric Code
- Determining the proper size (i.e., wattage) and number of units to achieve the desired light levels in a given application
- Methods to follow in making a luminaire layout. Cat. Nos. are shown, in many cases, for complete assemblies including mounting, reflector, globe, and guard, as well as individual components. In these cases, ordering can be done by component or by complete assembly.

Photometric and other technical data is included in each section for the luminaires it contains

Information relating to product families in the Lighting Section is shown as follows:

Section 1L Incandescent Lighting

(for use in hazardous [classified] and non-hazardous locations)

EVI Series Vaporgard™ Series
EV Series V Series
NDA Corro•Gard™ Series

Section 2L LED Luminaires

(for use in hazardous [classified] locations, non-hazardous locations, and marine locations)

EV LED Series
Hazard•Gard® EVLL Series
Hazard•Gard LPL Series
LL48 Series
Champ® VMV LED Series
Champ® FMV LED Series
Vaporgard™ LED Series
N2LPS Light-Pak™ Series
Ex-Lite Series
CCH UX Series
Champ® Pro PVM Series
Champ® Pro PFM Series
Vaporgard™ Pro P2L Series
Industrial High Bay LED Series
Endure™ LED Series

Section 3L High Intensity Discharge (H.I.D.) Lighting – Enclosed and Gasketed

(for use in hazardous [classified] locations, non-hazardous locations, and marine locations)

Indoor and outdoor vaportight luminaires for use in applications where dirt, moisture, and corrosion problems exist. Included are units with integral ballasts.

Champ® VMV Series
Champ® LMV Series
Champ® DMV Series
VMVIG/DMVIG Series
Champ® N2MV Series
Champ® NVMV Series

Section 4L High Intensity Discharge (H.I.D.) Lighting

(for use in hazardous [classified] locations) Indoor and outdoor luminaires and accessories. Included are luminaires with integral ballasts.

Hazard•Gard® EVLS
Hazard•Gard® EVLP
Hazard•Gard® EVM

Section 5L Fluorescent Lighting

(for use in hazardous [classified] locations and non-hazardous locations)

Indoor and outdoor fluorescent luminaires and accessories for application in all classes of hazardous and non-hazardous locations.

For hazardous locations	For non-hazardous locations
CPMV	NFL
EVF, EVFDR	
FVN, FVS	VF Vaporgard Series
EVFT, DMVF	
N2MVF, EVLPP	
VF, eLLK, nLLK	
eLLB20	

Section 6L Floodlights

(for use in hazardous [classified] locations and non-hazardous locations)

Champ® FMV Series
CPMV Champ-Pak™ Wall Pack
EVMA-S812 Hazard•Gard® Series
F2MV, FMV1000
FZD
RCDE
SSFMV Voyager nR™

Section 7L Luminaire Hangers and Accessories

(for use in hazardous [classified] locations and non-hazardous locations) A variety of luminaire hangers for use with the luminaires listed. Information on mounting accessories required and typical luminaire weights also included.

For hazardous locations	For non-hazardous locations
EAHC, EFHC	AL
EC	AHG
EFH	ARB
GUA, GUF	FHM
UNR	UNE, UNH, UNHC
CPS	UNJ
	UNJC

Section 8L Portable Lighting

A variety of portable luminaires for hazardous and non-hazardous applications.

VS
EVH
RCDER
EVP

Section 9L Emergency Lighting

(for use in hazardous [classified] locations) Emergency lighting for use in power outage situations. Also, exit signs and strobe warning lights.

N2LPS Light-Pak™ Series	CPMVFB
EXL Exit Sign	DMVFB
ELPS Light-Pak™ Series	N2MVFB
Ex-Lite	EVLPPFB
CCH UX Series	

Section 10L Specialty Lighting

Luminaires for use in applications where conventional lighting is not acceptable due to size and/or location, such as tank, instrument, and gauge applications.

For hazardous locations	For non-hazardous locations
EV – tank lights	V Observation
EVTL	
ELG – gauge light	

Quick Reference Chart

	Light Source				Emergency & Warning	WallPacks & Floodlights
Application Environment	LED	Incandescent	H.I.D. / Induction <ul style="list-style-type: none"> Pulse Start Metal Halide Metal Halide High Pressure Sodium 	Fluorescent <ul style="list-style-type: none"> Linear Long Twin Tube Compact 	<ul style="list-style-type: none"> Exit Signs Emergency Lighting 	<ul style="list-style-type: none"> Pulse Start Metal Halide Metal Halide High Pressure Sodium Incandescent
General Industrial	Section 2L Champ® Pro PVM Series, Champ® Pro PFM Series, Vaporgard™ Pro P2L Series, Industrial High Bay	Section 1L Vaporgard™, V Series, NDA Section 11L V160 Tank light	Section 3L LMV, DMV, VMV, N2MV Champ®, Champ Induction	Section 5L VF Series, NFL, FVN, FVS, DMVF, N2MVF	Section 2L Ex-Lite, CCH UX, N2LPS Light-Pak™ Section 9L DMVFB, N2MVFB	Section 6L F2MV, FMV, FMV1000
Marine/Wet Locations or 4X	Section 2L Champ® VMV LED, Vaporgard™ LED, EV LED	Section 1L NDA	Section 3L LMV, DMV, VMV, N2MV Champ® Section 4L EVLP, EVM Hazard•Gard®	Section 5L NFL, FVS, DMVF, N2MVF, CPMVF, EVFDR, EVFT Illuminator™	Section 2L Ex-Lite, CCH UX Section 9L DMVFB	Section 6L CPMV, F2MV, FMV, FMV1000
Corrosive	Section 2L Champ® VMV LED, Vaporgard™ LED, EV LED	Section 1L Vaporgard™, NDA	Section 3L LMV, DMV, VMV, N2MV Champ®, Champ Induction	Section 5L NFL, N2MVF, FVS, VF Series, DMVF, CPMVF	Section 2L Ex-Lite, CCH UX, N2LPS Light-Pak™ Section 9L DMVF-EXD Exit, N2MVFB, DMVFB	Section 6L CPMV, F2MV, FMV, FMV1000
Class I, Div. 1 or Zone 1	Section 2L EV LED, EVLL, LPL	Section 1L EV Section 10L EVTL, EVA160, EVO, ELG	Section 4L EVLP, EVLS, EVM Hazard•Gard®	Section 5L EVF, EVFDR, EVFT Illuminator™, EVLPPF, eLLK	Section 9L EXL Exit, EVLPPF-EXD Exit, ELPS Light-Pak™, EVLPPF	Section 6L FZD, EVM-S812, RCDE
Class I, Div. 2 and Zone 2	Section 2L Champ® VMV LED, Vaporgard™ LED, Champ® FMV LED, LL48	Section 1L Vaporgard™, NDA	Section 3L LMV, DMV, VMV, N2MV Champ®, Champ Induction	Section 5L VF Series, NFL, nLLK, eLLK, FVN, FVS, CPMVF, DMVF, N2MVF	Section 2L Ex-Lite Section 9L DMVF-EXD Exit, N2LPS Light-Pak™, DMVFB, N2MVFB	Section 6L CPMV, F2MV, FMV, FMV1000, FZD
Restricted Breathing • Class I, Div 2 and Zone 2 • Certified IEC Zone 2	Section 2L Champ® VMV LED, Champ® NFMV LED, Vaporgard™ NV2L LED		Section 3L LMV, DMV, VMV, N2MV Champ®, Champ Induction	Section 5L CPMVF, DMVF, N2MVF	Section 9L DMVFB, N2MVFB	Section 6L CPMV, F2MV, FMV
Class II Class III Simultaneous Presence	Section 2L Champ® VMV LED, EV LED, Vaporgard™ LED, Champ® FMV LED, EVLL	Section 1L EV Section 10L EVTL, EVO	Section 3L LMV, DMV, VMV, N2MV Champ®, Champ Induction Section 4L EVLP, EVM Hazard•Gard®	Section 5L FVN, nLLK, eLLK, FVS, DMVF, N2MVF, EVF, EVFDR, EVFT, EVLP	Section 2L Ex-Lite Section 9L EXL, N2LPS Light-Pak™, DMVFB, N2MVFB, ELPS Light-Pak™	Section 6L CPMV
Paint Spray			Section 8L EVP	Section 5L EVF, EVFT		
Portables		Section 8L VS, EVH, RCDE	Section 8L EVP	Section 8L EVH		

L Industrial Lighting Products

Lighting Layout Services

Lighting Application and Design

In the past, engineers had to calculate lighting layouts and design using complex mathematical formulas - also known as the "Lumen Method" and "Point-By-Point" Method. Today, there are software programs that can easily run these calculations very quickly. Lighting layouts, analysis, and design from Eaton's Crouse-Hinds deliver a real competitive advantage. For over 100 years, Eaton's Crouse-Hinds has been providing hazardous area lighting solutions. Our light fittings are manufactured to the highest standards and will provide years of reliable service and performance under the harshest conditions.

Lighting Software

Eaton's Crouse-Hinds' Luxicon Pro™ software program makes it very easy to perform lighting calculations and create professional quality designs. Our latest version, LUXICON® 2.5.25, is distributed free of charge and includes a tutorial to introduce users to its operation and several "Wizards" that will assist in a step-by-step process to create your own lighting design. You can also add in objects that will account for light inference caused by equipment, walls, and other obstructions in the work area. It will also provide detail point-by-point calculations and statistical analysis.

LuxiconPro™

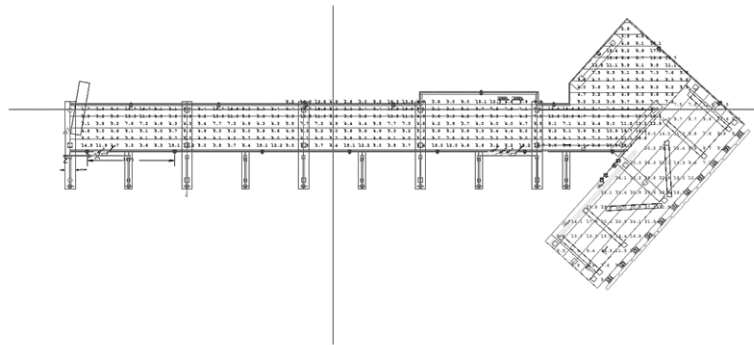

Point-by-point light calculation in plan view

Lighting Layout Services

Need help with a more complex lighting design or analysis? Then take advantage of our free lighting design service. Our lighting designers can provide you with lighting layouts for more complex projects that will interface with the latest version of AutoCAD drawings and will provide a more detailed lighting analysis.

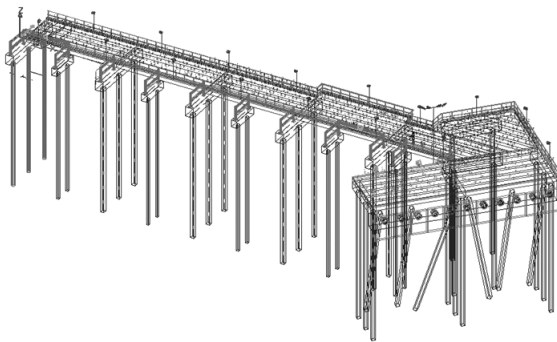

Calculations shown with light fixture placement

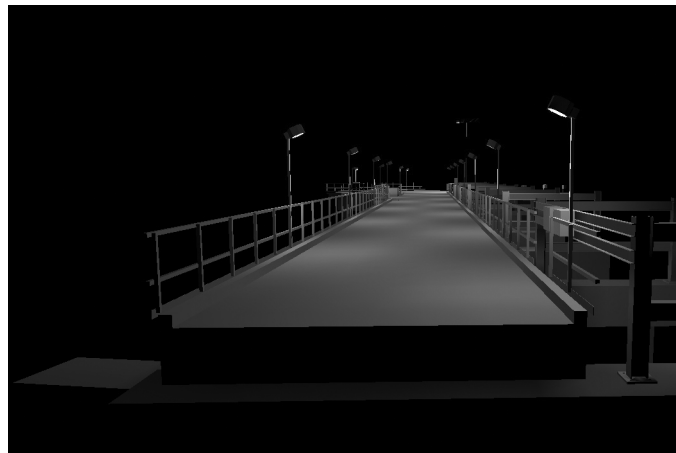

Illuminance rendering

Mercury Vapor Luminaires - Discontinuation Notice

Eaton's Crouse-Hinds no longer produces luminaires containing Mercury Vapor ballasts in any of our U.S. facilities.

In 2005, the U.S. government signed the Energy Policy Act of 2005. The law, commonly referred to as EPACT 2005, contained many new changes in requirements for energy production, energy transportation, and energy efficiency. One of those changes calls for the elimination of manufacturing and importation of Mercury Vapor (MV) ballasts in the United States after January 1, 2008.

Mercury Vapor ballasts have lower lumens per watt than alternative HID light sources and are far less energy-efficient than LED, High Pressure Sodium (HPS), or Metal Halide (MH) ballasts. As demand for energy-efficient lighting grows, we expect a subsequent drop in the usage of Mercury Vapor ballasts globally. This could lead to longer lead times and potentially worldwide discontinuation at some point in the future.

Eaton's Crouse-Hinds suggests the use of alternative technologies, such as LED, that provide better efficacy, color rendering, length of life, and environmentally friendlier solutions. Alternative HID light sources, such as High Pressure Sodium or Metal Halide, are also viable product solutions.

While we recommend switching to an alternative light source, there are many countries in the world that still allow the use of Mercury Vapor ballasts. As long as the ballasts and lamps remain available, we can still offer Mercury Vapor luminaires out of our manufacturing facilities located outside of the United States. The Mercury Vapor luminaires will be manufactured in our Eaton's Crouse-Hinds Mexico facility and shipped directly from there.

For available Mercury Vapor products, please contact customer service.



Alternative Solutions

Luminaire Type	Hours	Lumens	Lumens per Watt
LED			
VMV / PVM			
41W	60,000	3,515	77.39
67W	60,000	5,288	78.93
94W	60,000	7,404	78.77
114W	60,000	9,515	83.47
118W	60,000	10,935	92.67
FMV / PFM			
64W	60,000	4,386	68.53
89W	60,000	6,720	75.51
121W	60,000	8,478	70.07
149W	60,000	10,420	69.93
179W	60,000	12,940	72.29
V2L / P2L			
22W	60,000	1,633	74.23
EV LED			
30W	60,000	1,670	55.67
36W	60,000	2,248	62.44
EVLL			
80W	60,000	5,625	70.30
100W	60,000	6,750	67.50
130W	60,000	9,000	69.23
151W	60,000	10,500	69.54
175W	60,000	13,500	77.14
High Pressure Sodium			
100W	24,000	9,500	95.00
250W	24,000	28,500	114.00
400W	24,000	50,000	125.00
1000W	24,000	140,000	140.00
Metal Halide			
175W	10,000	13,500	77.00
250W	20,000	20,500	82.00
400W	20,000	36,000	90.00
1000W	12,000	110,000	110.00
Pulse Start Metal Halide			
175W	15,000	16,000	91.00
250W	15,000	23,800	95.00
400W	20,000	44,000	100.00
Induction			
55W	100,000	3,500	63.00
85W	100,000	6,000	70.00
165W	100,000	12,000	72.00
Mercury Vapor			
100W	24,000	4,100	34.00
175W	24,000	7,900	45.00
250W	24,000	12,100	48.00
400W	24,000	21,000	52.00
1000W	24,000	57,500	57.00

L Lamps Used With Eaton's Crouse-Hinds Luminaires

H.I.D. Medium Base
Series – LMV, EVLP_ 1

Lamp Watts	ANSI Ballast	Manufacturer			
		Lamp Catalog Number			
		GE	Osram/Sylvania	Phillips	Venture

High Pressure Sodium

50	S68	LU50/MED	LU50/MED	C50S68/M	
70	S62	LU70/MED	LU70/MED	C70S62/M	
100	S54	LU100/MED	LU100/MED	C100S54/M	
150	S55	LU150/MED	LU150/MED	C150S55/M	

Metal Halide

70	M98	MXR70/U/MED	MP70/U/MED	MHC70/U/M/3K	MH70W/U
100	M90	MXR100/U/MED	MP100/U/MED	MHC100/U/M/3K	MH100W/U
175*	M57	MVR175/U/MED	M175/U/MED	MH175/U/M	

Pulse Start Metal Halide

150	M102	MXR150/U/MED	MP150/U/MED		MH150W/U/PS
175	M137	MXR175/VBU/MED/PA			MS175W/BU/MED/PS

*For export only.



Lamps Used With Eaton's Crouse-Hinds Luminaires

H.I.D. Medium Base
Series – LMV, EVLP_1

L

Lamp Watts	ANSI Ballast	Manufacturer				Manufacturer			
		Lumens/Life (hrs)				Bulb			
		GE	O/S	PH	Venture	GE	O/S	PH	Venture

High Pressure Sodium

50	S68	4000/24K	4000/24K	4000/24K		B17	E17	ED17	
70	S62	6400/24K	6300/24K	6300/24K		B17	E17	ED17	
100	S54	9500/24K	9500/24K	9500/24K		B17	E17	ED17	
150	S55	16000/24K	15800/24K	16000/24K		B17	E17	ED17	

Metal Halide

70	M98	5500/12K	5200/15K	6200/10K	5600/15K	BD17	E17	ED17	ED17
100	M90	9000/15K	8500/15K	9300/12.5K	9000/15K	BD17	E17	ED17	ED17
175*	M57	13600/10K	14400/10K	13500/10K		BD17	ED17	ED17	

Pulse Start Metal Halide

150	M102	12500/15K	13300/15K		14000/15K	BD17	E17		ED17
175	M137	17700/15K			17500/15K	BD17	E17		ED17

*For export only.



L

Lamps Used With Eaton's Crouse-Hinds Luminaires

H.I.D. Mogul Base
Series - DMV, VMV, CPMV,
FMV, F2MV, EVLP_0, FZD

Lamp Watts	ANSI Ballast	Manufacturer			
		GE	Osram/Sylvania	Phillips	Venture

High Pressure Sodium

50	S68	LU50	LU50	C50S68	
70	S62	LU70	LU70	C70S62	
100	S54	LU100	LU100	C100S54	
150	S55	LU150/55	LU150/55	C150S55	

150 (100V)	S56	LU150/100	LU150/100	C150S56	
200	S66	LU200	LU200	C200S66	
250	S50	LU250	LU250	C250S50	
310	S67	LU310	LU310	C310S67	
400	S51	LU400	LU400	C400S51	
1000	S52	LU1000	LU1000	C1000S52	

Metal Halide

70	M98			MHC100/U/ED28/HR/4K	MH70W/U/ED28
100	M90				MH100W/U/ED28
175*	M57	MVR175/U	M175/U	MH175/U	
250*	M58	MVR250/U	M250U	MH250/U	
400*	M59	MVR400/U	M400/U	MH400/U	
400*	M59	MVR400/U/ED28	M400/U/BT-28	MH400/U/ED28	
1000	M47	MVR1000/U	M1000/U	MH1000/U	
1500	M48	MVR1500/HBD	M1500/BD	MH1500/BD	

Pulse Start Metal Halide

(Base up +/- 15%)

(Base up +/- 15%)

150	M102			CDM150/U/PS/4K ALTO	MH150W/U/ED28/PS
175	M137	MXR175/VBU/PA		MS175/BU/PS	MS175W/BU/PS
200	M136				MH200W/U/PS
250	M138	MXR250/VBU/PA		MS250/BU/PS	MH250W/HBU/PS
	M138				MH250W/HBD/PS
320	M132	MXR320/VBU/PA	MS320/PS/BU-ONLY	MS320W/BU/PS	MH320W/U/ED28/PS
350	M131				MH350W/U/PS
	M131				MH350W/U/ED28/PS
400	M135	MXR400/VBU/PA	MS400/PS/BU-ONLY	MS400/BU/PS	MH400W/HBU/PS
	M135				MH400W/HBD/PS
	M135				MH400W/HBU/ED28/PS
	M135				MH400W/HBD/ED28/PS
1000	M141				

HID Double Contact Metal Halide for EVP Series

70W		CMH70/TD/830/R7S	HQI-DE 70/WDX	CDM70/TD/830	
-----	--	------------------	---------------	--------------	--

*For export only.

Lamps Used With Eaton's Crouse-Hinds Luminaires

H.I.D. Mogul Base
Series - DMV, VMV, CPMV,
FMV, F2MV, EVM, EVLP_0, FZD

L

Lamp Watts	ANSI Ballast	Manufacturer				Manufacturer			
		Lumens/Life (hrs)				Bulb			
		GE	O/S	PH	Venture	GE	O/S	PH	Venture

High Pressure Sodium

50	S68	4000/24K	4000/24K	4000/24K		ED23 1/2	ET23 1/2	ED23 1/2	
70	S62	6400/24K	6300/24K	6300/24K		ED23 1/2	ET23 1/2	ED23 1/2	
100	S54	9500/24K	9500/24K	9500/24K		ED23 1/2	ET23 1/2	ED23 1/2	
150	S55	16000/24K	16000/24K	16000/24K		ED23 1/2	ET23 1/2	ED23 1/2	
150 (100V)	S56	15000/24K	15700/24K	16000/24K		ED28	BT28	ED28	
200	S66	22000/24K	22000/24K	22000/24K		ED18	ET18	ED18	
250	S50	28000/24K	29000/24K	28500/24K		ED18	ET18	ED18	
310	S67	37000/24K	37000/24K	37000/24K		ED18	ET18	ED18	
400	S51	51000/24K	50000/24K	50000/24K		ED18	ET18	ED18	
1000	S52	140000/24K	130000/24K	140000/24K		E25	E25	E25	

Metal Halide

70	M98				5600/15K				ED28
100	M90				9000/15K				ED28
175	M57	13600/10K	14400/10K	13500/10K		ED28	BT28	ED28	
250	M58	20800/10K	22000/10K	20500/20K		ED28	BT28	ED28	
400	M59	36000/20K	36000/20K	36000/20K		ED37	BT37	ED37	
400	M59	36000/20K	36000/20K	36000/20K		ED28	BT28	ED28	
1000	M47	105000/12K	110000/15K	110000/12K		BT56	BT56	BT56	
1500	M48	155000/3K	155000/3K	165000/3K		BT56	BT56	BT56	

Pulse Start Metal Halide

150	M102			13000/24K	14000/15K			ED23 1/2	ED28
175	M137	17200/15K		16000/15K	17500/15K	ED23 1/2		ED28	ED28
200	M136				21000/15K				ED28
250	M138	23000/15K		23800/15K	25000/15K	ED28		ED28	ED28
	M138				25000/15K				ED28
320	M132	31000/15K	32000/20K		33000/20K	ED28	BT28	ED28	ED28
350	M131				37000/20K				ED37
	M131				37000/20K				ED28
400	M135	44000/20K	41000/20K	44000/20K	44000/20K	ED37	BT37	ED37	ED37
	M135				44000/20K				ED37
	M135				44000/20K				ED28
	M135				44000/20K				ED28
1000	M141								ED28

L Lamps Used With Eaton's Crouse-Hinds Luminaires

Fluorescent Lamps

Lamp Watts	Base	Luminaire Series	Manufacturer		
			GE	Osram/Sylvania	Phillips

Compact

5W-T4	G23	VF	F5BX/SPX41/840	CF5DS/841	PL-S5W/27
7W-T4	G23	VF	F7BX/SPX35/835	CF7DS/835	PL-S7W/35
9W-T4	G23	VF	F9BX/SPX35/835	CF9DS/835	PL-S9W/35
13W-T4	GX23-2	DMVF (Discontinued)	F13DBX23T4/SPX35	CF13DD/835	PL-C13W/35/USA
26W-T4	GX24q-3	DMVF, N2MVF, CPMVF, EVLPF	F26TBX/SPX35/A/4P	CF26DT/E/IN/835	PL-T26W/35/4P/ALTO
32W-T4	GX24q-3	DMVF, N2MVF, CPMVF, EVLPF	F32TBX/SPX35/A/4P	CF32DT/E/IN/835	PL-T32W/35/4P/ALTO
42W-T4	GX24q-4	DMVF, N2MVF, CPMVF, EVLPF	F42QBX/SPX35/A/4P	CF42DT/E/IN/835	PL-T42W/35/4P/ALTO

Long Twin Tube

39	2G11	EVFT	F39/36/BX/SPX35	FT36DL/835	PL-L36W/35
40	2G11	NFL, FVS	F40/30BX/SPX35	FT40DL/835/RS	PL-L40W/35/RS

Linear

32W-T8	Medium Bipin	NFL, FVN, EVF, EVFDR	F32T8/SP35	F032/735	F32T8/TL735/ALTO
40 (34) W-T12	Medium Bipin	NFL, FVN, EVF, EVFDR	F40CW/RS/WM	F40CW/SS	F40CW/RS/EW/ALTO
54W-T5HO	Miniature Bipin	FVN	F54T5/841/WH/ECO	HO54W/835	F54T5/830/HO/ALTO
60W (800ma)-T12 High Output	Recessed Double Contact	FVN, EVF, EVFDR	F48T12/CW/HO	F48T12/CW/HO	F48T12/CW/HO
110W (1500ma)-T12 Very High Output	Recessed Double Contact	EVF, EVFDR	F48T12/CW/1500	F48T12/CW/VHO	F48T12/CW/VHO

Lamps Used With Eaton's Crouse-Hinds Luminaires

Incandescent & Quartz
(Halogen) Lamps

L

Lamp Watts	Base	Luminaire Series	Manufacturer		
			Lumens/Life (Hrs)		
			GE	Osram/Sylvania	Phillips

Compact

5W-T4	G23	VF	250/10K	230/10K	250/10K
7W-T4	G23	VF	400/10K	400/10K	400/10K
9W-T4	G23	VF	600/10K	580/10K	600/10K
13W-T4	GX23-2	DMVF (Discontinued)	810/10K	780/10K	860/10K
26W-T4	GX24q-3	DMVF, N2MVF, CPMVF, EVLPPF	1800/10K	1800/10K	1800/10K
32W-T4	GX24q-3	DMVF, N2MVF, CPMVF, EVLPPF	2200/10K	2400/10K	2400/10K
42W-T4	GX24q-4	DMVF, N2MVF, CPMVF, EVLPPF	3200/10K	3200/10K	3200/10K

Long Twin Tube

39	2G11	EVFT	2850/12K	2900/12K	2900/12K
40	2G11	NFL, FVS	3150/20K	3150/20K	3150/20K

Linear

32W-T8	Medium Bipin	NFL, FVN, EVF, EVFDR	2850/20K	2800/20K	2850/20K
40 (34) W-T12	Medium Bipin	NFL, FVN, EVF, EVFDR	2650/20K	2700/20K	2650/20K
54W-T5HO	Miniature Bipin	FVN	4600/30K	4450/24K	4750/35K
60W (800ma)-T12 High Output	Recessed Double Contact	FVN, EVF, EVFDR	4050/12K	4050/12K	4050/12K
110W (1500ma)-T12 Very High Output	Recessed Double Contact	EVF, EVFDR	6200/10K	6600/10K	7050/12K

L Lamps Used With Eaton's Crouse-Hinds Luminaires

Incandescent & Quartz
(Halogen) Lamps

Max Watts And Bulb Type	Luminaire Series	Manufacturer		
		GE	Osram/Sylvania	Phillips
25W T10	EXLD	25T10	25T10	25T10
50W PAR20	EVTL	50PAR20/H/SP10 50PAR20/H/FL25	50PAR20/CAP/NSP 50PAR20/CAP/NFL	50PAR20/HAL/NSP9 50PAR20/HAL/NFL30
52W A19 58W A19	ELG ELG	60A52WMP/98	60A52/SS/XL 58A19/62	60A-52A/99/EW
60W T10	EXL	60T10	60T10	60T10
65W BR30	EVO2376	75R30/SP/65WM	65BR30/SP	65BR30/SP20
75W ER30	EVO2376	75ER30	75ER30	75ER30
100W A19	EV 40 Series / EVI	100A (IF)	100A (IF)	100A (IF)
100W A21	V160, EV160, EVH, EV 15 Series / EVI	100A21 (IF)	100A21 (IF)	100A21 (IF)
100W A23	VS	100A23 120V	100A23	100A23
100W D.C. Bay	Suffix QTZ	Q100CL/DC	100Q/CL/DC	100Q/CL/DC
150W A21	Vaporgard 150W EV 10 Series / EVI EV 20 Series	150A (IF)	150A (IF)	150A (IF)
150W A23	V Series		150A23 (IF)	150A23/CL
150W PAR38	RCDE6		150PAR/FL	150PAR38/2FL
200W A23	Vaporgard 200W EV 10 Series / EVI		200A23 (IF)	200A (IF)
200W A25	Vaporgard 200W EV 15 Series / EVI			200A25/35
200W PS25	EV 15 Series / EVI		200PS25/99XL	
200W PS30	EV 20 Series / EVI EV 30 Series / EVI	200 130V	200PS/CL 130V	200 130V
300W PS25	Vaporgard 300W NDA EV 15 Series / EVI	300M		300M
300W PS30	Vaporgard 300W EV 20 Series / EVI EV 15 Series / EVI	300M/99 (130v)	300M/CL	300M/PS30
300W R40	RCDE6	300R/FL	300R40/FL	300BR/FL
300W PS35	EV 30 Series / EVI	300	300/CL	300
500W PS40	EV 30 Series / EVI	500PS40		500PS40
500W PAR64	RCDE10	500PAR64/MFL	500PAR64/MFL	500PAR64/MFL

Lamps Used With Eaton's Crouse-Hinds Luminaires

Incandescent & Quartz
(Halogen) Lamps

L

Max Watts And Bulb Type	Manufacturer			Manufacturer		
	Lumens			Life-Hours		
	GE	O/S	PH	GE	O/S	PH
25W T10	248	232	260	1000	1000	1000
50W PAR20	570	530	550	2500	2500	2000
	570	530	550	2500	2500	2000
52W A19	670	650	564	2500	2500	4250
58W A19	630	630	630	3000	3000	3000
60W T10	740	630	745	1000	1000	1000
65W BR30	775	640		2000	2000	2000
75W ER30	850	750		2000	2000	2000
100W A19	1710	1750	1650	750	750	750
100W A21	1710	1690	1680	750	750	750
100W A23	1600		1730	750	750	750
100W D.C. Bay	1600	1600	1600	2000	2000	2000
150W A21	2850	2780	2850	750	750	750
150W A23		2810	2475		750	1275
150W PAR38	1660	1660	1660	2000	2000	2000
200W A23		3930	3800		750	750
200W A25	2720	2720	2720	3500	3500	3500
200W PS25	3000	3000	3000	2500	2500	2500
200W PS30	2725	2665	2825	1950	1875	2120
300W PS25	6200		6280	750	750	750
300W PS30	3935	5870	6100	6800	7500	7500
300W R40	3700	3030	np	2000	2000	2000
300W PS35	5820	5700	5700	1000	1000	1000
500W PS40	9900	10100	10100	1000	1000	1000
500W PAR64	6500			2000	2000	2000

L Ballasts Used With Eaton's Crouse-Hinds Luminaires

High Pressure Sodium
Data

Watts	ANSI Code	Volts	Type R/HX/CWA	Starting Current	Operating Current	Input Watts	Kit Cat. #
50	S68	120	R-HPF	1.0	0.6	62	CHRBS050/120 CHRBS050/DT CHRBS050/220 50
		120 / 277	HX-HPF	0.7/0.3	0.6/0.3	66	
		120/240-50 Hz	HX-HPF	0.3/0.3	0.6/0.6	66	
70	S62	120	R-HPF	0.9	0.8	86	CHRBS070/120 CHRBS070/MT CHRBS070/MT CHRBS070/220 CHRBS070/480 CHRBS070/220 50
		120/208/240/277	HX-HPF	0.8/0.5/0.4/0.4	0.8/0.5/0.4/0.4	91	
		120/277/347	HX-HPF	.8/.4/.3	0.8/0.4/0.3	93	
		220	HX-HPF	0.4	0.4	91	
		480	HX-HPF	0.2	0.2	93	
		220/240-50 Hz	HX-HPF	.5/.4	.5/.4	94	
100	S54	120	R-HPF	1.5	1.1	115	CHRBS100/120 CHRBS100/MT CHRBS100/TT CHRBS100/220 CHRBS100/480 CHRBS100/220 50
		120/208/240/277	HX-HPF	1.3/0.8/0.7/0.6	1.2/0.7/0.6/0.5	130	
		120/277/347	HX-HPF	1.3/0.6/0.5	1.2/0.5/0.4	130	
		220	HX-HPF	0.7	0.6	130	
		480	HX-HPF	0.4	0.3	130	
		220/240-50 Hz	HX-HPF	0.5/0.5	0.7/0.6	130	
150 (55v)	S55	120	R-HPF	2.3	1.5	170	CHRBS150/120 CHRBS150/MT CHRBS150/TT CHRBS150/220 CHRBS150/480 CHRBS150/220 50
		120/208/240/277	HX-HPF	2.0/1.2/1.0/0.9	1.7/1.0/0.8/0.7	188	
		120/277/347	HX-HPF	2.0/0.9/0.5	1.7/0.7/0.6	188	
		220	HX-HPF	1.1	0.9	188	
		480	HX-HPF	0.5	0.4	188	
		220/240-50 Hz	HX-HPF	0.9/0.8	0.9/0.8	188	
150 (100v)	S56	120/208/240/277	CWA	1.2/0.7/0.6/.05	1.8/1.0/0.9/0.8	188	CHRBS150/MT CE CHRBS150/480 CE CHRBS150/220 50 CE
		480	CWA	0.3	0.4	188	
		220/240-50 Hz	R-HPF	0.9/1.0	0.9/0.8	175	
200	S66	120/208/240/277	CWA	1.4/0.8/0.7/0.6	2.4/1.4/1.2/1.0	250	CHRBS200/MT CHRBS/200/480
		480	CWA	0.4	0.6	250	
250	S50	120	CWA	1.7	2.5	295	CHRBS250/120 CHRBS250/MT CHRBS250/TT CHRBS250/220 CHRBS250/480 CHRBS250/220 50
		120/208/240/277	CWA	1.7/1.0/0.8/0.7	2.5/1.5/1.3/1.1	295	
		120/277/347	CWA	1.7/0.7/0.6	2.7/1.2/0.9	295	
		220	CWA	0.9	1.5	295	
		480	CWA	0.4	0.7	310	
		230-50 Hz	CWA	1.0	1.4	300	
400	S51	120	CWA	3.3	3.8	457	CHRBS400/120 CHRBS400/MT CHRBS400/TT CHRBS400/220 CHRBS400/480 CHRBS400/220 50
		120/208/240/277	CWA	3.3/1.8/1.5/1.4	3.8/2.2/1.9/1.7	464	
		120/277/347	CWA	3.3/1.4/1.0	3.8/1.7/1.3	464	
		220	CWA	1.6	2.1	457	
		480	CWA	0.8	1.0	464	
		230-50 Hz	CWA	1.9	2.0	465	
1000	S52	120/208/240/277	CWA	6.4/3.8/3.2/2.8	9.5/5.5/4.8/4.2	1100	CHRBS1000/MT CHRBS1000/TT CHRBS1000/220 CHRBS1000/480 CHRBS1000/220 50
		120/277/347	CWA	6.4/2.8/2.2	9.5/4.2/3.3	1100	
		220	CWA	3.6	5.0	1100	
		480	CWA	1.6	2.3	1100	
		220/240-50 Hz	CWA	6.0/5.6	5.2/4.8	1100	

Ballasts Used With Eaton's Crouse-Hinds Luminaires

Pulse Start Metal Halide
Data

L

Watts	ANSI Code	Volts	Type R/HX/CWA	Starting Current	Operating Current	Input Watts	Kit Cat. #
150	M102	120/208/240/277	HX-HPF	1.8/1.3/0.9/0.8	1.6/1.0/0.8/0.7	185	CHRBM150/MTS828 CHRBM150/TTS828
		120/277/347/480	HX-HPF	1.8/0.8/0.7	1.6/0.7/0.6	185	
175*	M137	120/208/240/277	Super CWA	1.0/0.6/0.5/0.4	1.8/1.1/0.9/0.8	208	CHRBM175/MTS828 CHRBMMVMV175/MTS828** CHRBM175/TTS828
		120/208/240/277	Super CWA	1.0/0.6/0.5/0.4	1.8/1.1/0.9/0.8	208	
		120/277/347/480	Super CWA	0.8/0.4/0.3	1.9/0.8/0.7	208	
200*	M136	120/208/240/277	Super CWA	0.8/0.4/0.4/0.3	2.0/1.2/1.0/0.9	232	CHRBM200/MTS828 CHRBM200/TTS828 CHRBM200/480S828
		120/277/347	Super CWA	0.7/0.3/0.3	2.1/0.9/0.7	232	
		480	Super CWA	0.2	0.5	232	
250*	M138	120/208/240/277	Super CWA	2.3/1.3/1.2/1.0	2.5/1.5/1.3/1.1	288	CHRBM250/MTS828 CHRBM250/TTS828
		120/277/347	Super CWA	2.0/0.9/0.8	2.5/1.1/0.9	290	
320*	M132	120/208/240/277	Super CWA	1.8/1.1/0.9/0.8	3.3/1.9/1.7/1.4	368	CHRBM250/MTS828 CHRBM250/TTS828 CHRBM250/220S828 CHRBM250/480S828 CHRBM250/220 50S828
		120/277/347	Super CWA	2.2/1.0/0.7	3.3/1.4/1.1	368	
		220	Super CWA	1.4	1.7	365	
		480	Super CWA	0.5	0.8	368	
		230 / 50	Super CWA	1.1	1.6	365	
400*	M135	120/208/240/277	Super CWA	2.9/1.7/1.5/1.3	3.8/2.2/1.9/1.7	452	CHRBM400/MT S828 CHRBM400/TTS828 CHRBM400/480S828 CHRBM400/220 50S828
		120/277/347	Super CWA	3.2/1.4/1.1	3.8/1.7/1.4	450	
		480	Super CWA	0.8	1.0	452	
		230 / 50	Super CWA	2.0	2.1	454	
1000	M141	120/208/240/277	Super CWA	7.8/4.0/3.7/3.2	9.0/5.2/4.5/3.9	1080	CHRBM1000/MTS828 CHRBM1000/347S828 CHRBM1000/480S828 CHRBM1000/220 50S828
		347	Super CWA	2.3	3.2	1075	
		480	Super CWA	1.7	2.4	1075	
		220/240-50 Hz	CWA	4.5/4.1	5.0/4.5	1090	

*EISA compliant.

**For VMV replacement only.

L

Ballasts Used With Eaton's Crouse-Hinds Luminaires

Metal Halide
Data

Watts	ANSI Code	Volts	Type R/HX/CWA	Starting Current	Operating Current	Input Watts	Kit Cat. #
70	M98	120/208/240/277	HX-HPF	0.6/0.3/0.3/0.3	0.8/0.5/0.4/0.4	88	CHRBM070/MT CHRBM070/TT CHRBM070/220 CHRBM070/220 50
		120/277/347	HX-HPF	0.6/0.2/0.2	0.8/0.4/0.3	88	
		220	HX-HPF	0.4	0.5	94	
		220/240-50 Hz	HX-HPF	0.7/0.6	0.5/0.4	95	
100	M90	120/208/240/277	HX-HPF	1.2/0.8/0.7/0.6	1.2/0.7/0.6/0.5	129	CHRBM100/MT CHRBM100/TT CHRBM100/220 CHRBM100/480 CHRBM100/220 50
		120/277/347	HX-HPF	1.2/0.5/0.4	1.2/0.5/0.4	129	
		220	HX-HPF	0.9	0.6	129	
		480	HX-HPF	0.3	0.3	132	
		220/240-50 Hz	HX-HPF	0.7/0.7	0.7/0.6	129	
175*	M57	120	CWA	1.3	1.8	210	CHRBM175/120 CHRBM175/MT CHRBM175/TT CHRBM175/220 CHRBM175/480 CHRBM175/220 50
		120/208/240/277	CWA	1.3/0.8/0.7/0.6	1.8/1.1/0.9/0.8	210	
		120/277/347	CWA	1.3/0.6/0.5	1.8/0.8/0.7	210	
		220	CWA	0.6	1.0	210	
		480	CWA	0.4	0.5	210	
		230 / 50	CWA	0.8	1.1	210	
250*	M58	120	CWA	1.0	2.6	294	CHRBM250/120 CHRBM250/MT CHRBM250/TT CHRBM250/220 CHRBM250/480 CHRBM250/220 50
		120/208/240/277	CWA	1.0/0.6/0.5/0.5	2.6/1.5/1.3/1.1	294	
		120/277/347	CWA	2.2/1.0/0.8	2.5/1.1/0.9	295	
		220	CWA	1.4	1.5	295	
		480	CWA	0.6	0.6	295	
		230 / 50	CWA	1.0	1.3	290	
400*	M59	120	CWA	3.0	4.0	456	CHRBM400/120 CHRBM400/MT CHRBM400/TT CHRBM400/220 CHRBM400/480 CHRBM400/220 50
		120/208/240/277	CWA	3.5/2.0/1.8/1.5	4.0/2.2/2.0/1.8	458	
		120/277/347	CWA	3.5/1.5/1.2	4.0/1.8/1.4	460	
		220	CWA	1.9	2.2	458	
		480	CWA	0.9	1.0	462	
		230 / 50	CWA	1.4	2.1	462	
1000	M47	120/208/240/277	CWA	7.8/4.0/3.7/3.2	9.0/5.2/4.5/3.9	1080	CHRBM1000/MT CHRBM1000/TT CHRBM1000/220 CHRBM1000/480 CHRBM1000/220 50
		120/277/347	CWA	7.8/3.2/2.5	9.0/3.9/3.2	1080	
		220	CWA	3.9	4.9	1080	
		480	CWA	1.9	2.3	1080	
		220/240-50 Hz	CWA	4.5/4.1	5.0/4.5	1090	
1500	M48	120/208/240/277	CWA	13.4/7.7/6.7/5.7	13.5/7.8/6.8/5.9	1605	CHRBM1500/MT CHRBM1500/TT CHRBM1500/220 CHRBM1500/480 CHRBM1500/220 50
		120/277/347	CWA	13.4/5.7/4.6	13.5/5.9/4.8	1615	
		220	CWA	7.3	7.4	1605	
		480	CWA	3.3	3.4	1625	
		220/240-50 Hz	CWA	6.9/6.3	7.5/6.9	1605	

*Must purchase directly from Advance.

Ballasts Used With Eaton's Crouse-Hinds Luminaires

Fluorescent Data

L

Luminaire Series	Lamp Type & Watts	Lamp Base	Lamp No. Qty.	Ballast Voltage	Starting Operating Amp	Input Watts	Kit Cat. #
Compact							
VF	9W T4	G23	2	120	0.4	22	CHRB2C018/120
DMVF, N2MVF, EVLPF	26W T4	GX24q-3	2	120	0.5	55	CHRB4C084/UNV
	26W T4	GX24q-3	2	220 / 240	0.3	55	CHRB4C084/UNV
	26W T4	GX24q-3	2	277	0.2	55	CHRB4C084/UNV
	26W T4	GX24q-3	2	347	0.2	44	CHRB4C084/347
	26W T4	GX24q-3	2	DC 12V	3.6	43	CHRB4C084/12VDC
	26W T4	GX24q-3	2	DC 24V	1.8	43	CHRB4C084/24VDC
DMVF, N2MVF, EVLPF	26W T4	GX24q-3	2	DC 125V	0.67	55	CHRB4C084/UNV
	32W T4	GX24q-3	2	120	0.6	68	CHRB4C084/UNV
	32W T4	GX24q-3	2	220 / 240	0.3	68	CHRB4C084/UNV
	32W T4	GX24q-3	2	277	0.3	68	CHRB4C084/UNV
	32W T4	GX24q-3	2	347	0.2	62	CHRB4C084/347
	32W T4	GX24q-3	2	DC 12V	4.4	60	CHRB4C084/12VDC
CPMVF, DMVF	32W T4	GX24q-3	2	DC 24V	2.2	60	CHRB4C084/24VDC
	32W T4	GX24q-3	2	DC 125V	0.67	68	CHRB4C084/UNV
	42W T4	GX24q-4	2	120	0.8	93	CHRB4C084/120
	42W T4	GX24q-4	2	277	0.3	68	CHRB4C084/277
	42W T4	GX24q-4	2	347	0.3	80	CHRB4C084/347
	42W T4	GX24q-4	2	DC 125V	0.67	93	CHRB4C084/UNV
Long Twin Tube							
NFL	40W T5	2G11	1	120	0.4	42	CHRBFT80/UNV
	40W T5	2G11	1	277	0.2	42	CHRBFT80/UNV
	40W T5	2G11	1	347	0.1	44	CHRBFT80/347
	40W T5	2G11	1	120 - 277	0.2	41	CHRBFT80/UNV
FVS	40W T5	2G11	2	120	0.6	76	CHRBFT080/UNV
	40W T5	2G11	2	277	0.3	73	CHRBFT080/UNV
	40W T5	2G11	2	347	0.2	70	CHRBFT080/347
	40W T5	2G11	2	120 - 277	0.3	74	CHRBFT080/UNV
EVFT	36/39W	2G11	2	120	0.6	74	CHRBFT078/120
	36/39W	2G11	2	277	0.3	74	CHRBFT078/277
	36/39W	2G11	2	220 / 240	0.3	71	CHRBFT078/220

Note:

For 3 lamp luminaires, order one 1 lamp ballast and one 2 lamp, lamp ballast. Add current and watts values.

For 4 lamp luminaires, order two 2 lamp, lamp ballasts. Double currents and watts values.

L

Ballasts Used With Eaton's Crouse-Hinds Luminaires

Fluorescent Data

Luminaire Series	Lamp Type & Watts	Lamp Base	Lamp No. Qty.	Ballast Voltage	Starting Operating Amp	Input Watts	Kit Cat. #
LINEAR							
NFL, FVN, EVF & EVFDR	32W T8	Med Bipin	1	120	0.3	35	CHRBFL064/UNV
	32W T8	Med Bipin	1	277	0.2	35	CHRBFL064/UNV
	32W T8	Med Bipin	1	347	0.1	32	CHRBFL64/347
	32W T8	Med Bipin	1	220 / 240	0.3	38	CHRBFL064/UNV
	32W T8	Med Bipin	2	120	0.5	58	CHRBFL064/UNV
	32W T8	Med Bipin	2	277	0.2	58	CHRBFL064/UNV
	32W T8	Med Bipin	2	347	0.1	50	CHRBFL64/347
	32W T8	Med Bipin	2	220	0.4	58	CHRBFL064/UNV
NFL, FVN, EVF & EVFDR	40(34W)T12	Med Bipin	1	120	0.4	46	CHRBFL080/120
	40(34W)T12	Med Bipin	1	277	0.2	46	CHRBFL080/277
	40(34W)T12	Med Bipin	1	347	0.2	52	CHRBFL40/347
	40(34W)T12	Med Bipin	1	220 50	0.2	51	CHRBFL40/220 50
	40(34W)T12	Med Bipin	2	120	0.6	73	CHRBFL080/120
	40(34W)T12	Med Bipin	2	277	0.3	80	CHRBFL080/277
	40(34W)T12	Med Bipin	2	347	0.2	62	CHRBFL80/347
	40(34W)T12	Med Bipin	2	220 / 240	0.2	71	CHRBFL80/220
FVN	54W T5 HO	Med Bipin	2	120 / 277	1.03 / 0.43	120 / 117	CHRBFL054/UNV
FVN, EVF & EVFDR	60W (800ma) T12 HO	Recessed Double Contact	1	120	0.9	79	CHFBFL120/120
	60W (800ma) T12 HO	Recessed Double Contact	1	277	0.5	82	CHFBFL120/277
	60W (800ma) T12 HO	Recessed Double Contact	1	220 50	0.7	140	CHFBFL120/220 50
	60W (800ma) T12 HO	Recessed Double Contact	2	120	1.2	133	CHFBFL120/120
	60W (800ma) T12 HO	Recessed Double Contact	2	277	0.5	131	CHFBFL120/277
	60W (800ma) T12 HO	Recessed Double Contact	2	220 50	1.0	224	CHFBFL120/220 50
EVF & EVFDR	110W (1500ma) T12 VHO	Recessed Double Contact	1	120	1.7	130	CHRBFL220/120
	110W (1500ma) T12 VHO	Recessed Double Contact	1	277	0.6	137	CHRBFL220/277
	110W (1500ma) T12 VHO	Recessed Double Contact	2	120	2.2	230	CHRBFL220/120
	110W (1500ma) T12 VHO	Recessed Double Contact	2	277	0.9	241	CHRBFL220/277

Note:

For 3 lamp luminaires, order one 1 lamp ballast and one 2 lamp, lamp ballast. Add current and watts values.

For 4 lamp luminaires, order two 2 lamp, lamp ballasts. Double currents and watts values.

Description	Page No.
Application	see page 880
<hr/>	
Class I, Division 1 Hazardous Area Luminaires	
EVI Series Groups C, D	see pages 881–889
EV Series Groups A, B, C, D	see page 890
<hr/>	
Class I, Division 2 and Industrial Luminaires	
Vaporgard™ Series	see page 891
V Series	see page 900
NDA Corro•Gard™ Series	see page 904

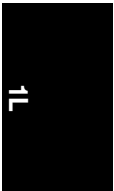

1L Incandescent Luminaires

General Information

Applications:

Incandescent luminaires are used:

- Indoors or outdoors in industrial locations; for general area or spot lighting
- In tunnels, building entrances or similar locations, where moisture, dirt, chemicals, vibration or rough usage are a problem
- Either mounted directly in the conduit system or attached to cast outlet boxes, by means of pendant, ceiling, wall bracket or stanchion mountings
- In areas made hazardous by presence of flammable vapors, gases, or dusts

Considerations for Selection:

Environmental:

- What is the area classification (NEC)/(CEC) of the location in which the luminaires will be installed?

Lighting levels required:

- What wattage fixture(s) will provide the desired light level?

Physical arrangement:

- Type of luminaire mounting needed

**Table 500.8(C)
Identification Numbers**

Maximum Temperature		Temp. Class
Deg. C	Deg. F	(T Code)
450	842	T1
300	572	T2
280	536	T2A
260	500	T2B
230	446	T2C
215	419	T2D
200	392	T3
180	356	T3A
165	329	T3B
160	320	T3C
135	275	T4
120	248	T4A
100	212	T5
85	185	T6

EVI Series Explosionproof Incandescent Luminaires

Factory Sealed 100–500W Medium and Mogul Base

Cl. I, Div. 1, Groups C, D
Cl. I, Zone 1 & 2, Group IIB
Cl. II, Groups E, F, G (Max
150W–Med. base)

Cl. III & Simultaneous Presence
(Max 150W–Med. base)
Marine and Wet Locations
Type 4X; IP66

1L

Applications:

EVI series incandescent luminaires are used:

- For Type 4X, marine, wet location and hose down environments.
- Where a consistent light level relatively unaffected by extremes in ambient temperature (–40°C to +65°C) is required.
- In areas that require lamps to reach full illumination immediately.
- In areas that require lamps to be frequently turned on and off.
- Indoors and outdoors in locations which are hazardous due to the presence of flammable vapors or gases, ignitable dusts, or ignitable fibers and flyings.
- Where a luminaire is required for tough environmental conditions involving corrosives, water, dust and extreme temperatures.
- Manufacturing plants, heavy industrial facilities, industrial process facilities such as refineries, chemical, petrochemical, pharmaceutical and platforms.
- For lighting of loading docks, tunnels, stairways, storage closets and task lighting.

Features:

- Ambient suitability to 65°C.
- Standard 90°C rated building wire for 150W max 40°C ambient application – represents more than 75% of all applications.
- Type 4X, marine outdoor locations.
- Factory sealed – no external seals required.
- Quick connect – fixture threads onto the mounting module for easy installation.
- One size luminaire for all medium base incandescent lamps through 300W.
- One size luminaire for all mogul base incandescent lamps through 500W.
- Small compact size – ceiling mount is 13 $\frac{3}{4}$ " long.
- Shock absorbing receptacle.
- Easy to assemble and relamp.
- Silicone gaskets seal out dirt and moisture.
- Epoxy powder coat for corrosion resistance.
- Same mounting modules as used with the EVM and EVLP series.

Certifications and Complies:

- NEC & CEC:
 - Class I, Division 1, Groups C, D
 - Class I, Zone 1, Group IIB
 - Class II, Groups E, F, G
 - Marine Locations, Wet Locations, Enclosure Type 4X, IP66
- UL Listed
- cUL Listed (Certified by UL to CSA Standards)
- NEC:
 - Class III; Simultaneous Presence
- UL Standards:
 - 844 Electric Fixture Hangers for Hazardous Locations
 - 1598 Luminaires
 - 1598A Luminaires for Installation on Marine Vessels
- CSA Standards:
 - C22.2 No. 137

Standard Materials:

- Body, mounting modules and guard – copper-free aluminum
- Globe – heat and impact-resistant glass
- Gaskets – silicone
- External hardware – stainless steel
- Reflectors – *Krydon*[®] fiberglass-reinforced polyester

Standard Finishes:

- Copper-free aluminum – Corro-free™ epoxy powder coat
- Stainless steel – Natural
- *Krydon*[®] reflectors – High reflectance white

Electrical Ratings:

Sources/Wattages

- Medium Base – Maximum 300W (PS25)
- Mogul Base – Maximum 500W (PS40)

Voltages

- Medium Base 120V (250V with suffix /250)
- Mogul Base 277V

Hub Size

- $\frac{3}{4}$ " or 1" NPT pendant, ceiling, wall mount
- $\frac{3}{4}$ " NPT bulkhead mount

Options:

Description

- 250V luminaire for export applications (medium base only)

Suffix

/250

Accessories:

- Reflectors – For Ordering by Components see page 883.

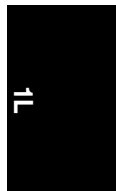







1L EVI Series Explosionproof Incandescent Luminaires

**Factory Sealed
100–500W Medium and Mogul Base**

Cl. I, Div. 1, Groups C, D
Cl. I, Zone 1 & 2, Group IIB
Cl. II, Groups E, F, G (Max
150W–Med. base)

Cl. III & Simultaneous Presence
(Max 150W–Med. base)
Marine and Wet Locations
Type 4X; IP66

	Mounting Style	Hub Size	EVI301 Series Medium Base with EV505 Guard (Max. 300W PS25)	EVI501 Series Mogul Base with EV503 Guard (Max. 500W PS40)
	Pendant Mount	3/4"	EVIA2301	EVI A2501
		1"	EVIA3301	EVI A3501
	Ceiling Mount	3/4"	EVICX2301	EVICX2501
		1"	EVICX3301	EVICX3501
	Wall Mount	3/4"	EVIBX2301	EVIBX2501
		1"	EVIBX3301	EVIBX3501
	Bulkhead Mount	3/4"	EVIBH2301	—
		1"	—	—
	Stanchion Mount	1 1/4"	EVIJ4301	EVIJ4501
	Luminaire with Guard Less Mounting Module		EVI301	EVI501

Note: Medium base luminaires (EVI301 Series) – For A19 lamps up to 100W, use Leviton socket extension Leviton catalog number 2005.
Mogul base luminaires (EVI501 Series) – For PS30 medium base lamps, use Eaton's Wiring Devices socket adapter catalog number 332.

1L

EVI Series Explosionproof Incandescent Luminaires

Ordering By Components

1L

Factory Sealed 100–500W Medium and Mogul Base

EVI Luminaires are available in components.

A complete luminaire consists of:

- I. Mounting Module
- II. EVI Luminaire Body and Globe Assembly
- III. Guard, Reflector

I. Mounting Module:

Type	Conduit	Cat. #
Pendant	3/4"	EVMP2
	1"	EVMP3
Ceiling and Wall Box	3/4"	EV22
	1"	EV33
Wall Bracket Arm	3/4"	EV22 & EV87
	1"	EV33 & EV87
Stanchion	1 1/4"	EVMJ4
Bulk Head	3/4"	EVIJ2

II. Luminaire Body and Globe Assembly with Guard:

Type	Cat. #
Medium Base	EVI301
Mogul Base	EVI501

III. Guards and Reflectors:

Type	Cat. #
Guard – Fits EVI301 Series (medium base)	EV505
Guard – Fits EVI501 Series (mogul base)	EV503
Dome Reflector – Fits EVI301 Series (medium base)	RD636
Angle Reflector – Fits EVI301 Series (medium base)	RA636
Dome Reflector – Fits EVI501 Series (mogul base)	RD739
Angle Reflector – Fits EVI501 Series (mogul base)	RA739

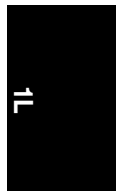

1L EVI Series Explosionproof Incandescent Luminaires

Family Tree
Temperature Performance Data

Factory Sealed
100–500W Medium and Mogul Base

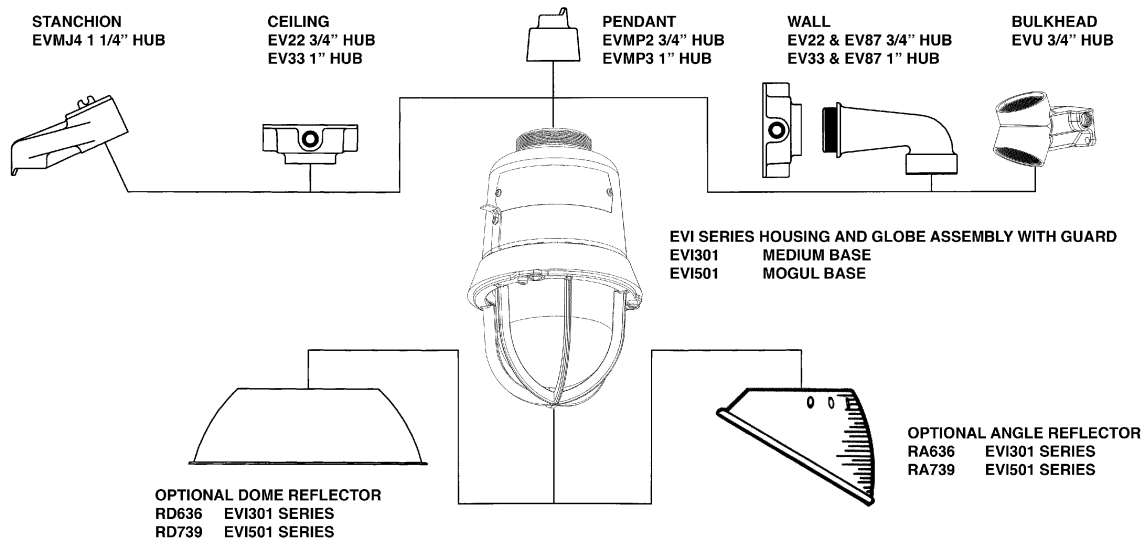

Temperature Performance Data:

Type	Watts/Lamp	Class I, Div. 1 (Class I, Zone 1)			Class II	Simultaneous Presence	Supply Wire Temp (°C)		
		Ambient			Ambient	Ambient	Ambient		
EVI301 Medium Base	100W/A21 or A19	40°C	55°C	65°C	40°C	40°C	40°C	55°C	65°C
	150W/A21	T4	T3C	T3C	T3C	T3C	90°C	105°C	125°C
	200W/A23 or A25	T4	T3C	T3C	T3C	T3C	90°C	105°C	125°C
	300W/PS25	T3	T2D	T2C	—	—	105°C	125°C	125°C
EVI501 Mogul Base	200W/PS30	T3	T2D	T2C	—	—	105°C	125°C	125°C
	300W/PS35	T4A	T4	T4	T3A	T3A	90°C	90°C	105°C
	500W/PS40	T4	T3C	T3C	—	—	90°C	90°C	105°C
		T3A	T3	T3	—	—	105°C	125°C	125°C

1L

EVI Series Explosionproof Incandescent Luminaires

Medium Base Dimensions and Weights

1L

**Factory Sealed
100–500W Medium and Mogul Base**

Medium Base EVI Luminaire Dimensions In Inches:

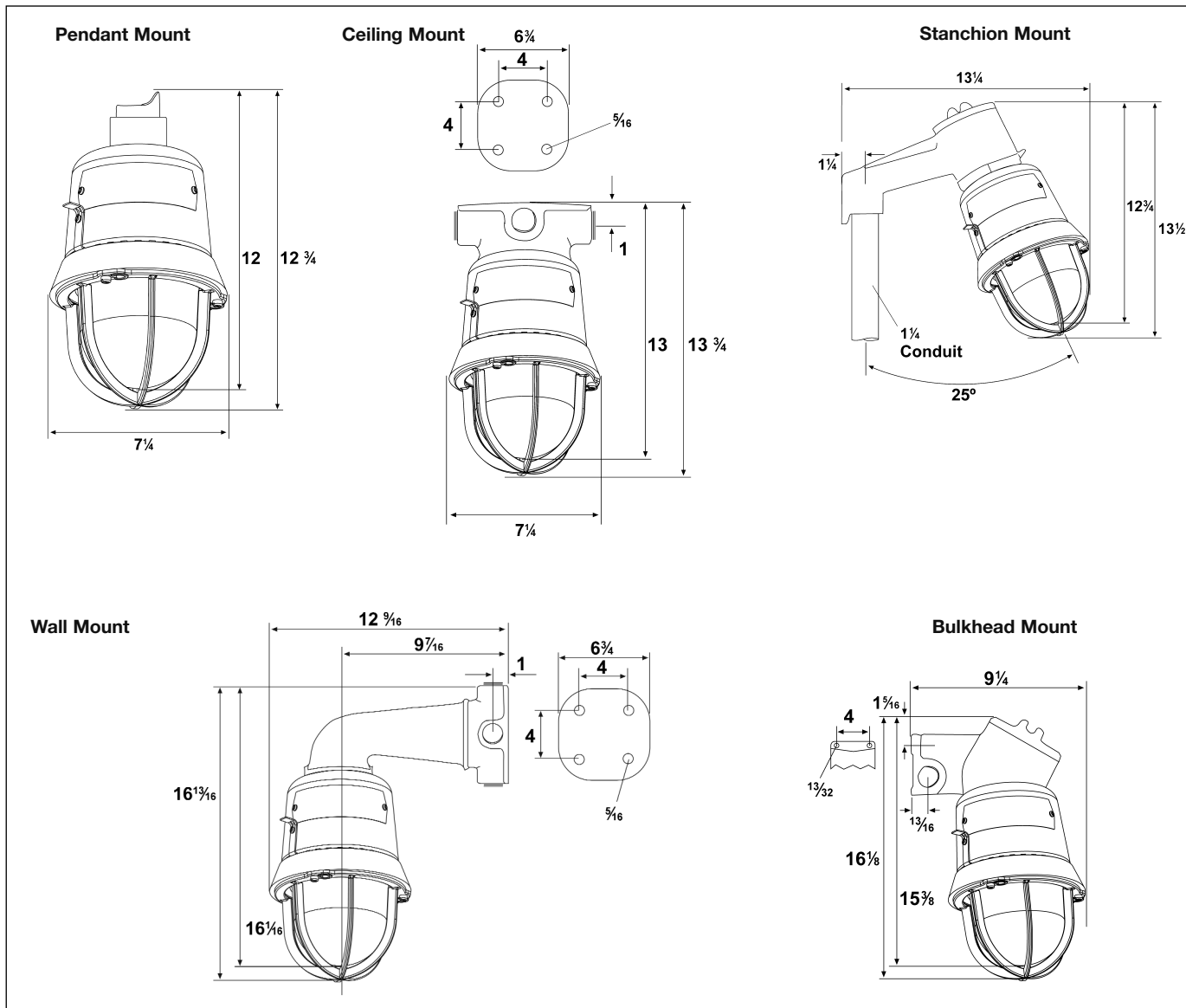

Medium Base Net Luminaire Weights (lbs.):

EVI301 with guard 11 lbs.

Add mounting modules:

Pendant	1.0 lbs.
Ceiling	2.0 lbs.
Wall	4.5 lbs.
Bulkhead	2.2 lbs.
Stanchion	2.5 lbs.

Add for reflectors:

RD636 (Dome Reflector, Small)	1.5 lbs.
RA636 (Angle Reflector, Small)	1.0 lbs.
RD739 (Dome Reflector, Small)	2.0 lbs.
RA739 (Angle Reflector, Small)	1.4 lbs.



1L EVI Series Explosionproof Incandescent Luminaires

Mogul Base Dimensions and Weights

Factory Sealed
100–500W Medium and Mogul Base

Mogul Base EVI Luminaire Dimensions In Inches:

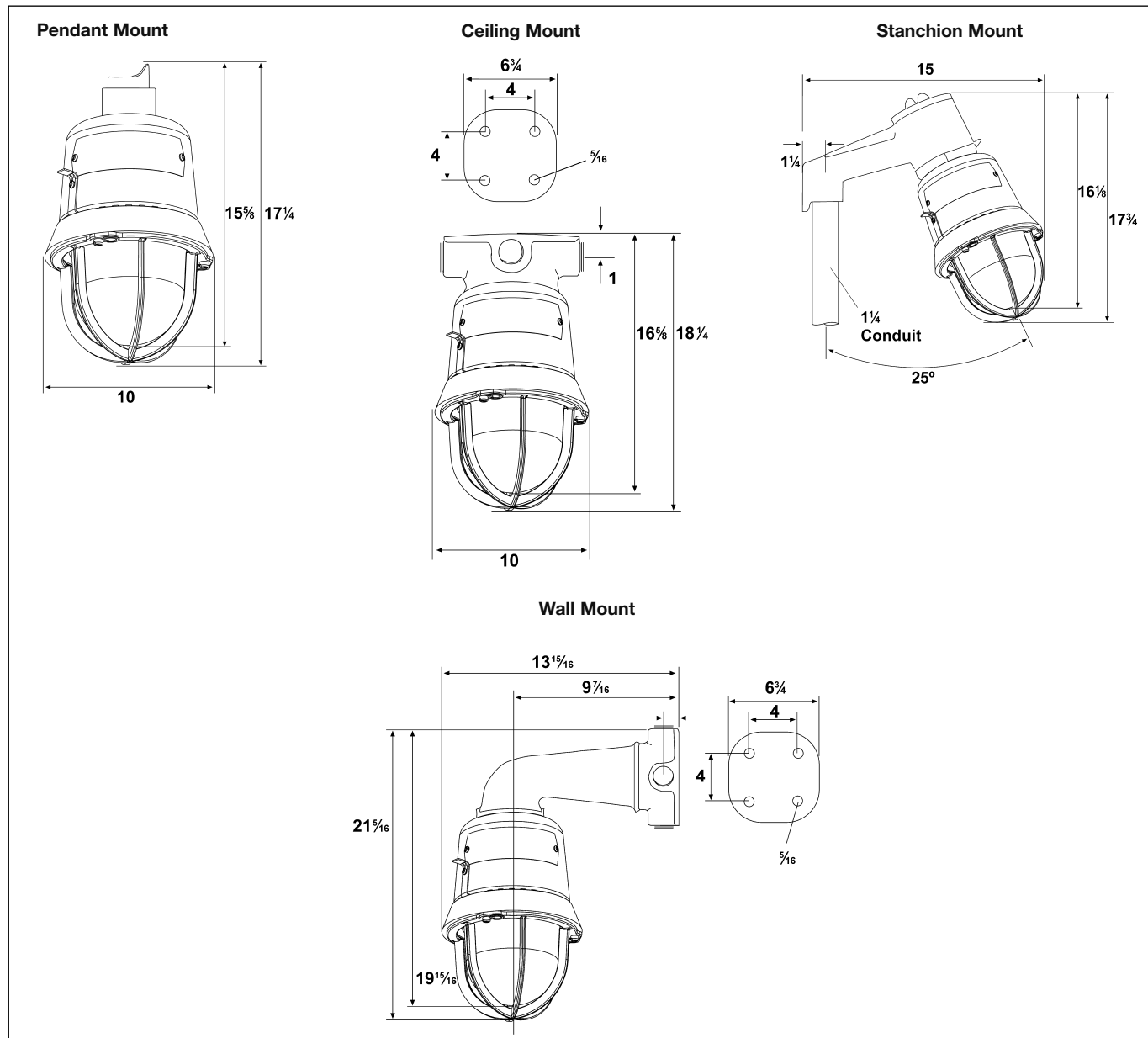

1L

Mogul Base Net Luminaire Weights (lbs.):

EVI501 with guard 24 lbs.

Add mounting modules:

Pendant	1.0 lbs.
Ceiling	2.0 lbs.
Wall	4.5 lbs.
Bulkhead	2.2 lbs.
Stanchion	2.5 lbs.

Add for reflectors:

RD636 (Dome Reflector, Small)	1.5 lbs.
RA636 (Angle Reflector, Small)	1.0 lbs.
RD739 (Dome Reflector, Small)	2.0 lbs.
RA739 (Angle Reflector, Small)	1.4 lbs.

EVI Series Explosionproof Incandescent Luminaires

Photometric Data

1L

**Factory Sealed
100-500W Medium and Mogul Base**

Medium Base

Luminaire with Globe and Guard
EVICX2301 Lamp: 300W/PS25 Incandescent

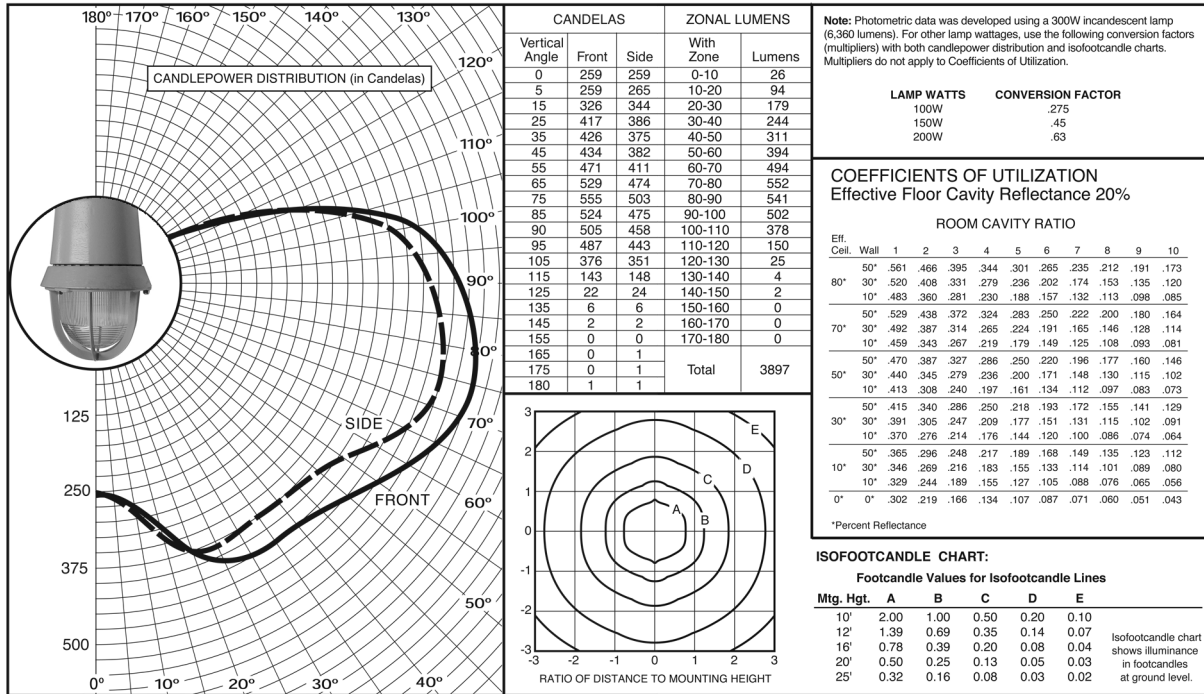

Medium Base

Luminaire with Globe and Dome Reflector (Less Guard)
EVICX2300 Lamp: 300W/PS25 Incandescent

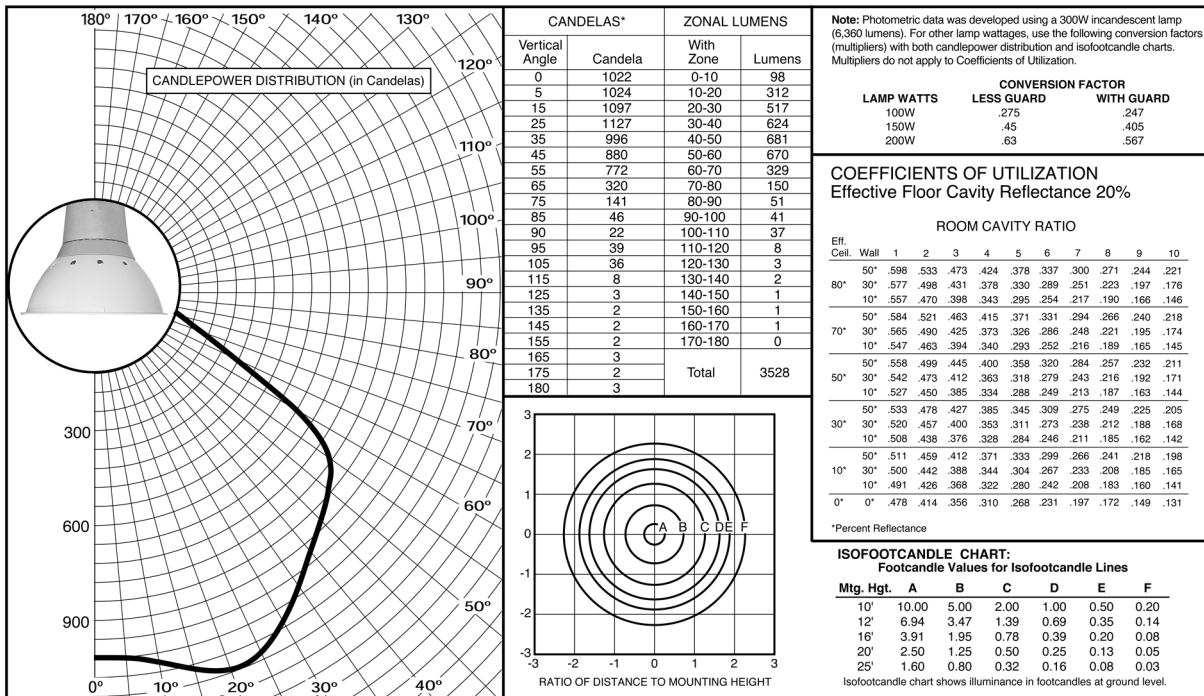

EVI Series Explosionproof Incandescent Luminaires

**Factory Sealed
100-500W Medium and Mogul Base**

Medium Base

Luminaire with Globe and 30° Angle Reflector (Less Guard)

EVICX2300 Lamp: 300W/PS25 Incandescent

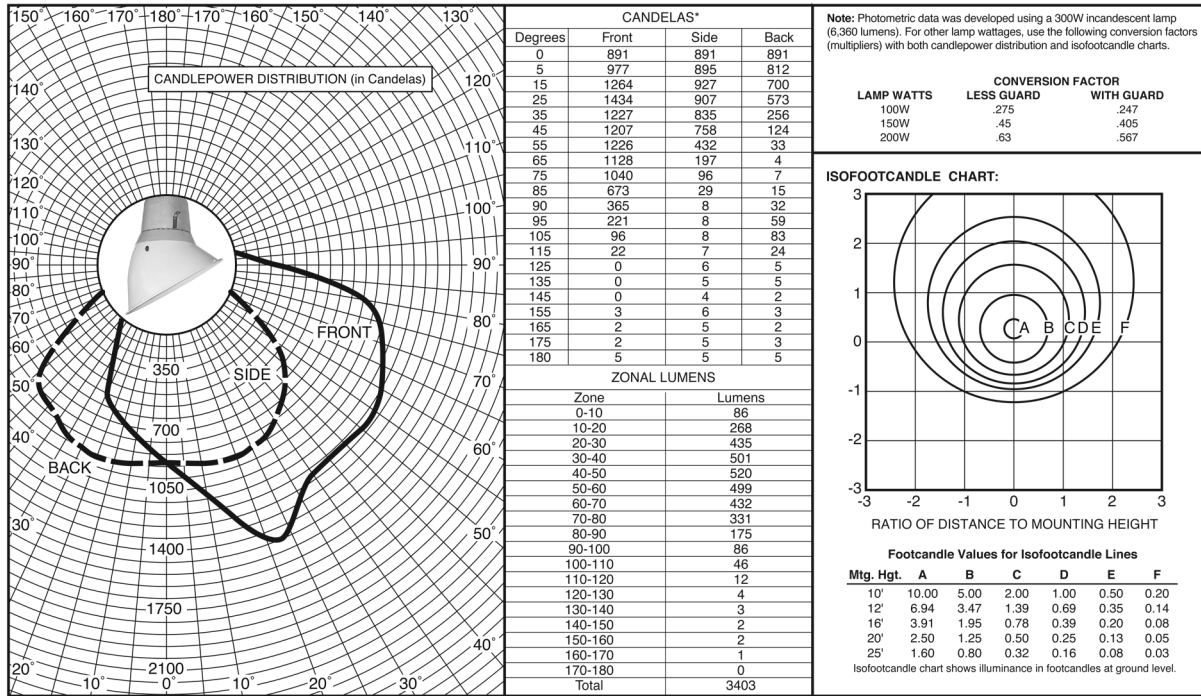

Mogul Base

Luminaire with Globe and Guard

EVIA2501 Lamp: 500W/PS40 Incandescent

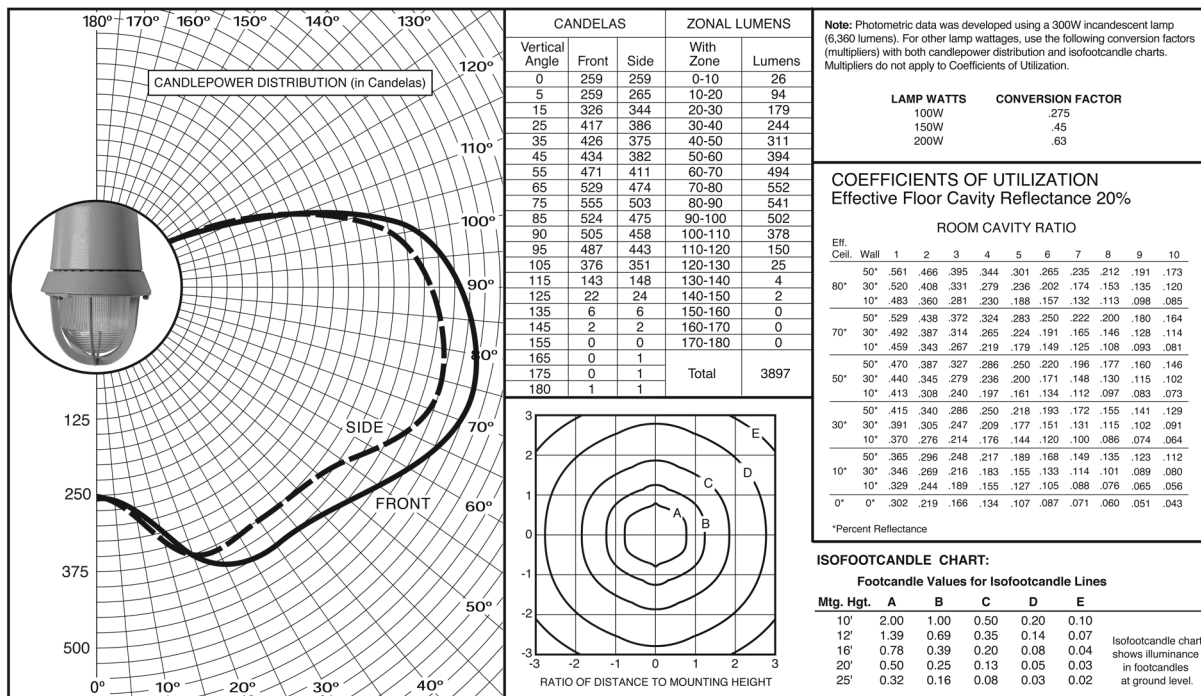

EVI Series Explosionproof Incandescent Luminaires

Photometric Data

1L

**Factory Sealed
100-500W Medium and Mogul Base**

Mogul Base

Luminaire with Globe and Dome Reflector (Less Guard)

EVI A2500 Lamp: 500W/PS40 Incandescent

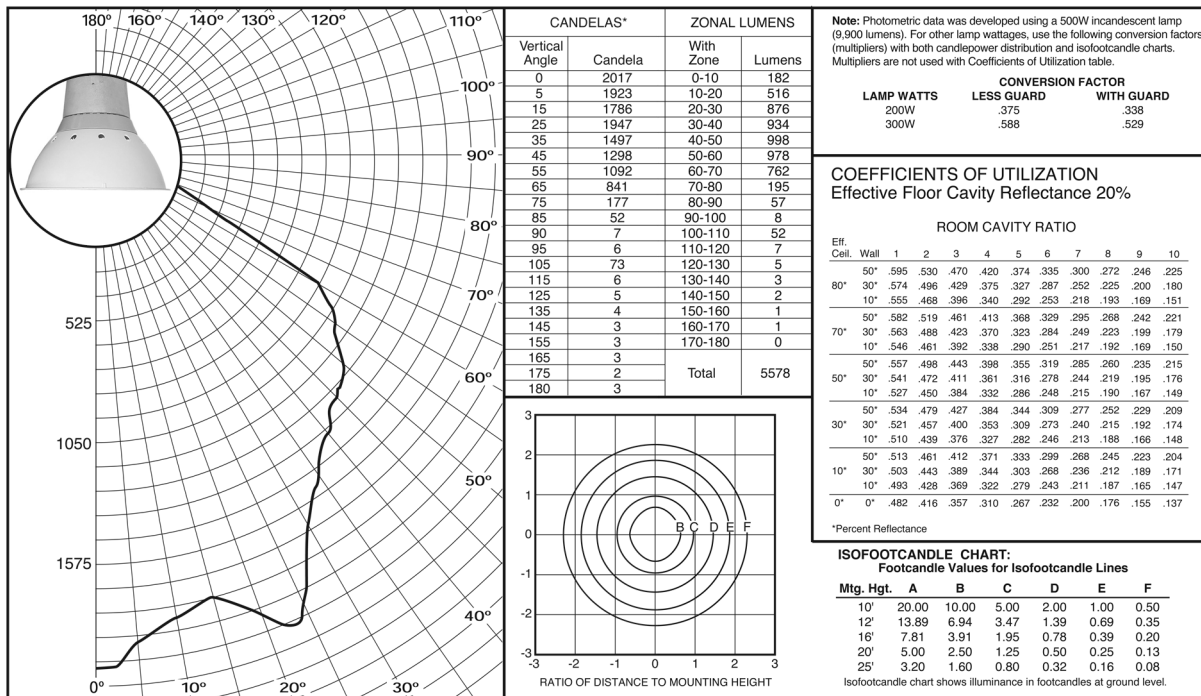

Mogul Base

Luminaire with Globe and Angle Reflector (Less Guard)

EVI A2500 Lamp: 500W/PS40 Incandescent

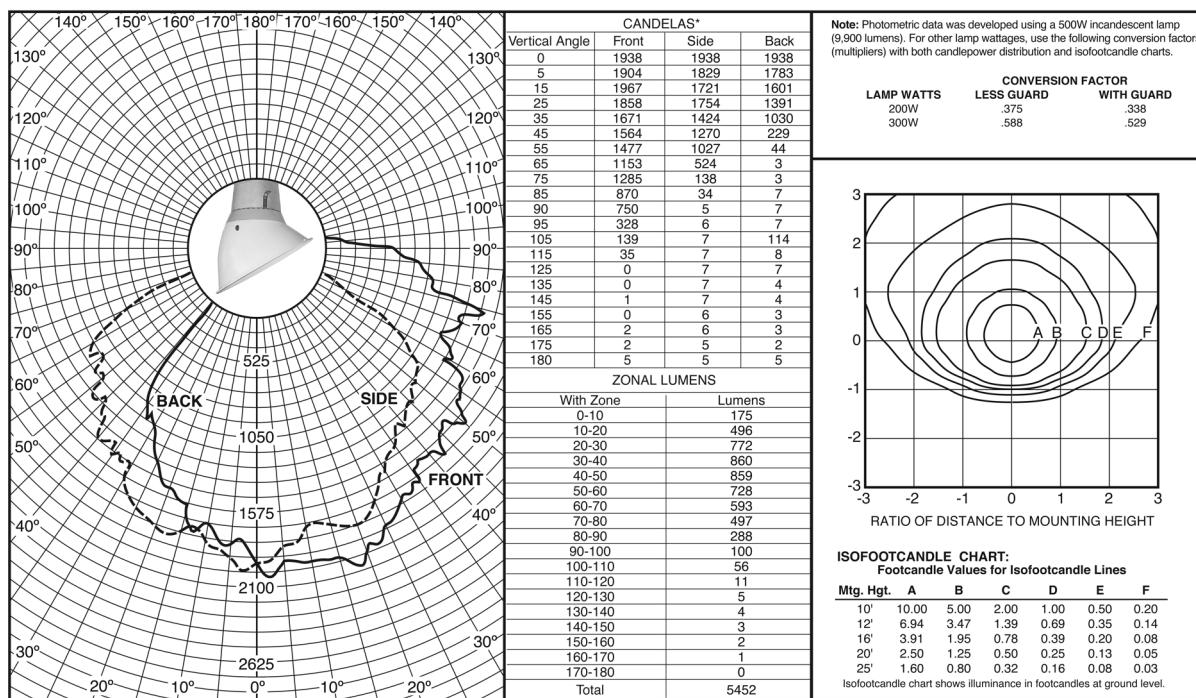

1L EV Incandescent Luminaires

Factory Sealed

Cl. I, Div. 1 and 2, Groups A, B, C, D – Pendant Mount
 Cl. I, Div. 1 and 2, Groups B, C, D – Ceiling and Bracket Mount
 Wet Locations
 NEMA 3, 3R

Applications:

EV292 Series luminaires are used:

- To provide incandescent lighting in locations made hazardous due to the presence of hydrogen, gases or vapors of an equivalent hazard, such as manufactured gas
- Hydrogen areas of process industries, missile bases where hydrogen fuel is used and gas manufacturing plants
- In areas of lesser hazard than indicated above
- EVA292 pendant mount luminaire is also suitable for use in locations made hazardous due to the presence of acetylene

Features:

- Flamtight threaded joints – no external seal needed
- Easy to assemble and relamp
- Shock absorbing receptacle
- Gasket seals out dirt and liquids
- Positive locking of globe holder
- Heat and impact resistant globe
- Inner reflector eliminates upward spill light
- Lightweight
- Corrosion resistant
- Dome and 30° angle reflectors available

Certifications and Complies:

- NEC/CEC:
 - Class I, Divisions 1 and 2, Groups A, B, C, D – pendant mount
 - Class I, Divisions 1 and 2, Groups B, C, D – ceiling and bracket mount
- UL Standard: 844
- CSA Standard: C22.2 No. 137

Standard Materials:

- Globes – heat and impact resistant glass
- Luminaire and bracket arm – copper-free aluminum
- Reflectors – Krydon® fiberglass-reinforced polyester
- Back box – Feraloy® iron alloy

Standard Finishes:

- Aluminum – epoxy powder coat
- Krydon – high reflectance white
- Feraloy – electrogalvanized and aluminum acrylic paint

Size Ranges:

- 3/4" conduit hub

Capacity Ranges:

- 300 watt, PS-30 medium base lamps

Temperature Performance Data:

Style	Class I UL	Ambient Temp. °C	Supply Wire °C
Pendant	T3A	25 / 40	150°C
Ceiling	T3A	25 / 40	150°C
Bracket	T3A	25 / 40	150°C

Note: Photometric curves and data are the same as shown for EV Groups C, D series.



Pendant style with RD725 dome reflector

Pendant style with RA725 30° angle reflector

Pendant style without reflector

Ordering Information:

Style	Max. Lamp Size	Hub Size (In.)	Without Reflector Cat. #	Dome Reflector Cat. #	30° Angle Reflector Cat. #
Pendant	300 watt, PS-30 (medium base)	With Guard 3/4"	EVA292	RD725	RA725
Ceiling	300 watt, PS-30 (medium base)	With Guard 3/4"	EVCX292	RD725	RA725
Bracket	300 watt, PS-30 (medium base)	With Guard 3/4"	EVBX292	Not Applicable	

Dimensions In Inches:

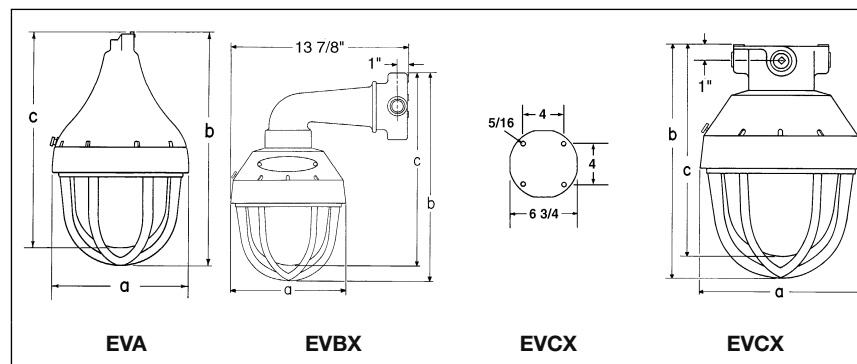

	EVA	EVBX	EVCX	Reflector Type	Diameter
a	8 7/8"	8 7/8"	8 7/8"	Dome	16"
b	16 3/8"	18 1/8"	14 3/8"	30° Angle	16"
c	14 7/8"	16 5/8"	12 7/8"		

Applications:

Vaporgard series incandescent luminaires are used:

- Indoors or outdoors in industrial locations where enclosed and gasketed fixtures are required
- In tunnels, building entrances and similar locations, where moisture, dirt, chemicals, vibration or rough usage are a problem
- For flush or surface mounting on ceiling or wall; pendant or in conduit systems; with or without a cast outlet box

Features:

- Designed to exclude dirt, moisture and corrosive vapors from the interior of the luminaires and the conduit system
- There are no screws to remove as the shock-absorbing socket strap is keyhole slotted and removes quickly for ease of wiring
- The glass globe-guard assembly is installed and/or removed as a unit, making it necessary to handle only one piece in relamping
- There are no crevices to accumulate a dirt or dust build-up and fixture has an attractive finish with a smooth, dust and dirt shedding design
- Configured glass globe has vertical fluting and stippled bottom which provides for more even light distribution and glare elimination
- For non-hazardous locations, shatterproof plastic polycarbonate globes are available for use with the 200 watt series
- Reversible offset socket mounting strap permits use of various size lamps while holding light center in same position for maximum light output and efficiency
- Shock absorbing medium base lamp socket

Krydon® fiberglass-reinforced polyester reflectors:

- Reflectance is equivalent to the finest porcelain enamel
- Cannot corrode – no enamel to chip and rust
- Ultraviolet inhibitors are incorporated in the material to prevent discoloration and brittleness

Certifications and Compliances:

- Wet locations
- NEC/CEC:
 - Class I, Division 2
- UL Standard: 1598
- CSA Standard: C22.2 No. 9
- UL/CSA Fixture Fitting

Standard Materials:

- Bodies and guards – copper-free aluminum
- Globes
 - Heat and impact resistant tempered glass
 - Colored glass non-tempered (G55, G56, G57, G58)
 - Plastic polycarbonate (G63, G65, G67)
- Reflectors – Krydon® fiberglass-reinforced polyester

Standard Finishes:

- Bodies and guards – epoxy powder coat
- Krydon material – high reflectance white

Options:

The following options are available from the factory by adding suffix to fixture Cat. No.:

Description	Suffix
• Teflon coating on globe for increased shatter protection (G24 globe 200 watt series only)	S808
• 250V nameplate for export applications.....	/250
• Plastic polycarbonate globe	see page 894

Ratings (Electrical/Size):

- Up to 300 watt, PS-30 medium base lamp
- ½" to 1¼" hubs
- 120V nameplate is standard – for NEC compliance
- 250V nameplate is optional. Supplied when ordered with suffix: /250

Class I, Division 2 Temperature Performance Data:

(Based on 40°C ambient)

Lamp Watts	T-Number	Supply Wire °C
150	T2A	150°C
200	T2B	200°C
300	T2B	150°C

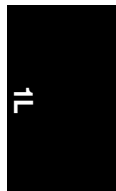

1L

**VAPORGARD™ Incandescent
Luminaires**

Cl. I, Div. 2, Groups A, B, C, D
Wet Locations
NEMA 3, 3R

Enclosed and Gasketed

**Pendant Mount –
VDA Series**



Hub Size	Series	Max. Lamp Size	Complete Cat. # with globe/guard	Luminaire Components Cat. #s		
				Pendant Body	Globe	Guard
1/2" 3/4" 1"	150	150 watt A-21	VDA15GP	VDA15	G54	P50
	150		VDA25GP	VDA25	G54	P50
	150		VDA35GP	VDA35	G54	P50
1/2" 3/4" 1"	200	200 watt A-23	VDA12GP	VDA12	G24	P21
	200		VDA22GP	VDA22	G24	P21
	200		VDA32GP	VDA32	G24	P21
1/2" 3/4" 1"	300	300 watt PS-25 & PS-30	VDA13GP	VDA13	G34/G251	P22
	300		VDA23GP	VDA23	G34/G251	P22
	300		VDA33GP	VDA33	G34/G251	P22

**Thru-Feed –
VDC Series**



Hub Size	Series	Max. Lamp Size	Complete Cat. # with globe/guard	Luminaire Components Cat. #s		
				Thru-Feed Body	Globe	Guard
1/2 or 3/4"	150	150 watt A-21	VDC25GP	VDC25	G54	P50
	200		VDC22GP	VDC22	G24	P21
	300		VDC23GP	VDC23	G34/G251	P22

**Ceiling Mount for
Recessed 4" Round
Box – VXH Series**



Series	Max. Lamp Size	Complete Cat. # with globe/guard	Luminaire Components Cat. #s		
			Lamp Socket Body	Globe	Guard
150	150 watt A-21	VXH15GP	VXH15	G54	P50
200	200 watt A-23	VXH12GP	VXH12	G24	P21
300	300 watt PS-25 & PS-30	VXH13GP	VXH13	G34/G251	P22

**Ceiling Mount with
Junction Box –
VXHF Series**



Hub Size	Series	Max. Lamp Size	Complete Cat. # with globe/guard	Luminaire Components Cat. #s			
				Lamp Socket Body	Globe	Guard	Junction Box
1/2 or 3/4"	150	150 watt A-21	VXHF25GP	VXH15	G54	P50	VXF20
	200		VXHF22GP	VXH12	G24	P21	VXF20
	300		VXHF23GP	VXH13	G34/G251	P22	VXF20

Note: All fixtures supplied with 1/2" reducers, except for pendant mount.

1L

VAPORGARD™ Incandescent Luminaires

Cl. I, Div. 2, Groups A, B, C, D
Wet Locations
NEMA 3, 3R

1L

Enclosed and Gasketed

Wall Mount – VXHT Series



Hub Size	Series	Max. Lamp Size	Complete Cat. # with globe/guard	Luminaire Components Cat. #s			
				Wall Bracket Mounting Module	Body	Globe	Guard
1/2 or 3/4"	150	150 watt A-21	VXHT25GP	VXT20	VXH15	G54	P50
1/2 or 3/4"	200	200 watt A-23	VXHT22GP	VXT20	VXH12	G24	P21
1/2 or 3/4"	300	300 watt PS-25 & PS-30	VXHT23GP	VXT20	VXH13	G34/G251	P22

Wall Mount – Adapter Kit

Description	Cat. #
Mounts wall mount VXHT Series to a 4" Round Box	VXT K1

Wall Mount with Junction Box – VXHBF Series



Hub Size	Series	Max. Lamp Size	Complete Cat. # with globe/guard	Luminaire Components Cat. #s				
				Wall Bracket Mounting Module	Body	Globe	Guard	Junction Box
1/2 or 3/4"	150	150 watt A-21	VXHBF25GP	VXT20	VXH15	G54	P50	VXF20
1/2 or 3/4"	200	200 watt A-23	VXHBF22GP	VXT20	VXH12	G24	P21	VXF20
1/2 or 3/4"	300	300 watt PS-25 & PS-30	VXHBF23GP	VXT20	VXH13	G34/G251	P22	VXF20

Stanchion Mount – VXHA Series



Hub Size	Series	Max. Lamp Size	Complete Cat. # with globe/guard	Luminaire Components Cat. #s			
				Stanchion Mounting Module	Body	Globe	Guard
1 1/4"		150 watt A-21	VXHA45GP	VXA4	VXH15	G54	P50
1 1/4"		200 watt A-23	VXHA42GP	VXA4	VXH12	G24	P21
1 1/4"		300 watt PS-25 & PS-30	VXHA43GP	VXA4	VXH13	G34/G251	P22

Note: All fixtures supplied with 1/2" reducers, except for pendant mount.

1L VAPORGARD™ Incandescent Luminaires

Parts and Accessories

Medium Base Lamp Receptacle with Strap Shock Absorbing

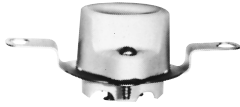

Description	Cat. #
Shock Absorbing Medium Base Lamp Receptacle with Strap	V84

Globes† and Guards



150 and 200W globe 300W globe

Plastic Globes⊙



Shatterproof polycarbonate plastic globe†

Reflectors



Dome



30° Angle

Max. Lamp Size	Dome Cat. #	30° Angle Cat. #
150 watt, A-21	RD64	RA64
200 watt, A-23, A-25, PS-25 and 300 watt, PS-30	RD71	RA71

Max. Lamp Size

Color	Max. Lamp Size		
	150 Watt, A-21 Cat. #	200 Watt, A-23, A-25, PS-25 Cat. #	300 Watt, PS-25, PS-30 Cat. #
Clear (heat-resisting)	G54	G24	G34G251
Green	G55*	G25	
Blue	G56*	G26	
Red	G57*	G27	
Amber	G58*	G28	

Applications:

For use in:

- Food processing plants and canneries, dairies, breweries and bakeries
- Emergency lighting

Features:

- Shatterproof, which precludes contamination of food products with broken particles of glass
- Designed to comply with U.S. Dept. of Agriculture specification for food processing plants
- Provides protection against vandalism, with resultant lower replacement and maintenance costs
- Particularly adaptable for use on emergency police or fire alarm boxes
- Same size as G24 series glass globes. Existing installations can be changed to plastic globes simply by replacing globe
- For use with 200 watt series luminaires such as VDA22, etc.
- For use without guard

Guards for Glass Globes (Not for use with plastic globes)



Guard P50 and P21 Guard P22

Max. Lamp Size	Cat. #
150 watt, A-21	P50
200 watt, A-23, A-25, PS-25	P21
300 watt, PS-30 (with G251 only)	P22

Color	Max. Wattage, Lamp Size	Cat. #
Natural	200 watt, A-23	G63
Green	200 watt, A-23	G65
Red	200 watt, A-23	G67

Note: Polycarbonate globes for non-hazardous locations only.

VXFT – 5 Hubs, 4 Plugs



Hub Size (In.)	Cat. #
1/2	VXFT10
3/4	VXFT20

For use when rear wiring entry is required. Use in lieu of VXF10 or VXF20.

Mounting Adapter Kit



VXT-K1

Description	Cat. #
Allows for the mounting of non-Eaton's Crouse-Hinds outlet boxes to the VXT20 wall mount bracket and VXH ceiling mount bracket	VXT K1

†Prior to wash-down, globes must be cool.

⊙Lamp must be mounted in vertical position base up to 45°C (stanchion) only.

*With G55, G56, G57, G58 color globes, maximum lamp size is 60 watt for outdoor applications.

§G24 is available with a TEFLON® coating for increased shatter protection by adding suffix S808 (stanchion) only.

■Globe G251 required when guard P22 is used. Use globe G34 when guard is not used.

‡All glass globes are configured type, having fluted side and stippled bottom.

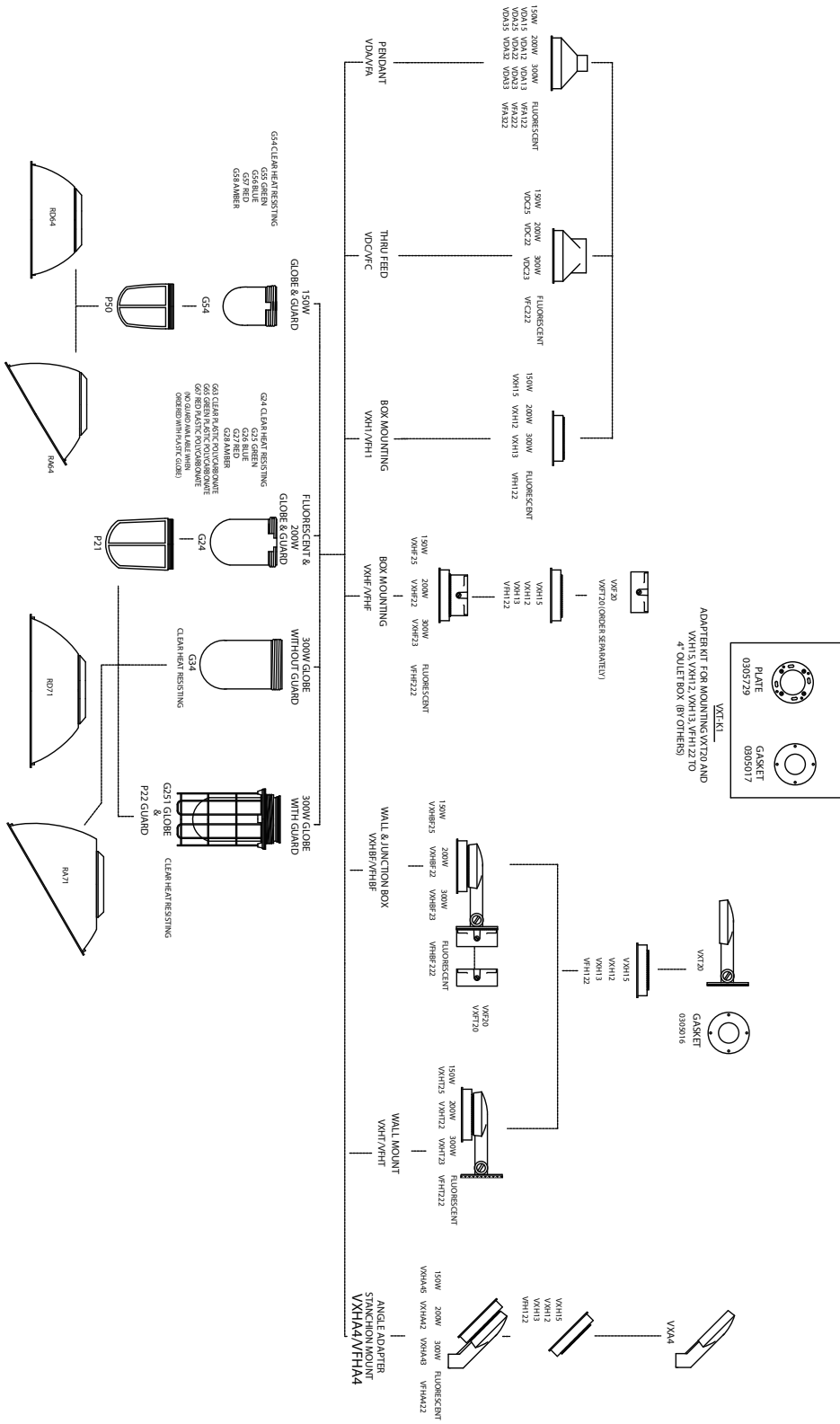

Luminaire VXHA45GPRA

Lamp: 150W/A-21

Total Bare Lamp Lumens: 2850

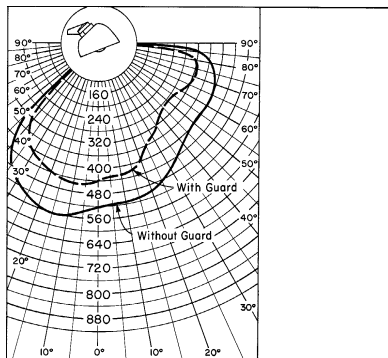

	Total Lumens	Eff. %
With Guard	1490	52.3
Without Guard	1881	66.0

Measurements taken from A-A' plane.



Luminaire VXHA42GPRA

Lamp: 300W/PS-30

Total Bare Lamp Lumens: 6300

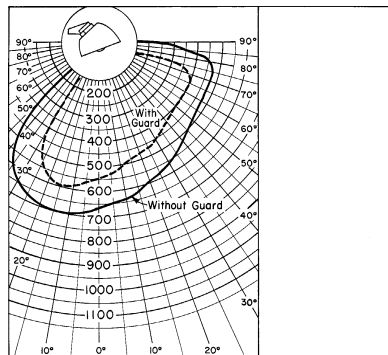

	Total Lumens	Eff. %
With Guard	3630	57.6
Without Guard	4271	67.8

Measurements taken from A-A' plane.



Luminaire With Globe, 30° Angle Reflector and With or Without Guard

Lamp: 100W/A-21 through 200W/A-23

Total Bare Lamp Lumens: 4000

All data provided is for 200W/A-23 incandescent lamp. Use following candlepower/lumen multipliers for other lamp sizes:
100W 0.42; 150 W0.7

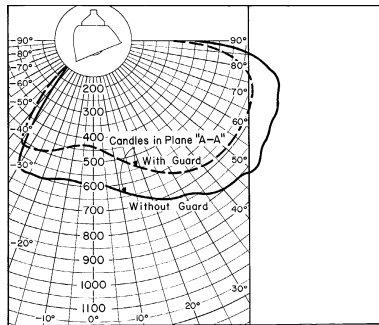

Measurements taken from A-A' plane.



Lamp Size	Without Guard		With Guard	
	Total Lumens	Eff. %	Total Lumens	Eff. %
100W	1141		949	
150W	1890		1582	
200W/A-23	2700	67.5	2260	56.5
200W/PS-25	2174		1819	

Luminaire With Globe, 30° Angle Reflector and With or Without Guard

Lamp: 300W/PS-30

Total Bare Lamp Lumens: 6000

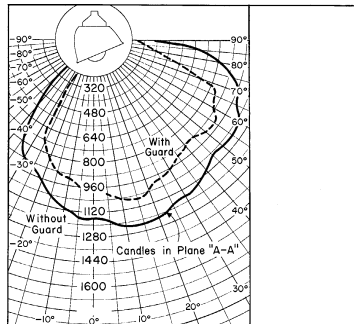

Measurements taken from A-A' plane.



	Total Lumens	Eff. %
With Guard	3360	56.0
Without Guard	3954	65.9

1L

**Lamp: 100W/A-21 through 200W/PS-25
Total Bare Lamp Lumens: 4000**

All data provided is for 200W/A-23 incandescent lamp. Use following candela/lumen multipliers for other lamp sizes:
100W 0.42; 150W 0.7; 200W/PS-25 0.82

Luminaire With Globe and With or Without Guard

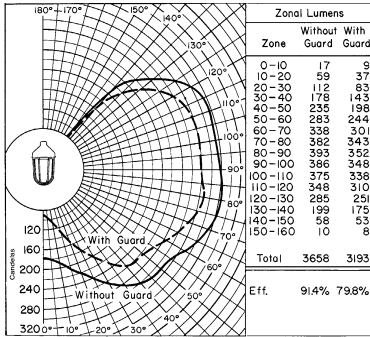

Example: Zonal Lumens for 200W/A-23 lamp with guard for 0-40° is 272 Zonal Lumens for 150W lamp with guard for 0-40° is 272 x 0.7 = 190.

Luminaire With Globe, Dome Reflector and With or Without Guard

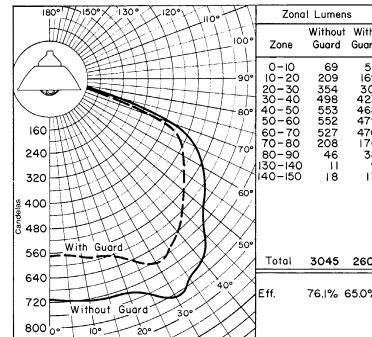

Example: Zonal Lumens for 200W/A-23 lamp with guard for 0-40° is 948 Zonal Lumens for 150W lamp with guard for 0-40° is 948 x 0.7 = 664.

Coefficient of Utilization

Effective Floor Cavity Reflectance 20%

% Reflectance Eff. Ceil.	% Reflectance Wall	Room Cavity Ratio				
		1	2	3	4	5
80	50	.654	.549	.471	.407	.353
	30	.608	.486	.400	.333	.282
	10	.567	.432	.345	.277	.228
70	50	.603	.506	.434	.375	.326
	30	.563	.449	.370	.309	.260
	10	.523	.401	.320	.257	.211
50	50	.509	.424	.363	.312	.273
	30	.477	.380	.313	.260	.220
	10	.449	.341	.271	.218	.179
30	50	.422	.349	.297	.255	.223
	30	.399	.315	.259	.214	.180
	10	.376	.285	.225	.180	.147
10	50	.343	.280	.237	.202	.176
	30	.324	.253	.206	.170	.142
	10	.307	.230	.180	.143	.115
% Reflectance Eff. Ceil.	% Reflectance Wall	Room Cavity Ratio				
		6	7	8	9	10
80	50	.315	.279	.249	.226	.201
	30	.244	.210	.183	.162	.140
	10	.193	.164	.137	.118	.100
70	50	.289	.257	.230	.208	.185
	30	.225	.194	.170	.150	.130
	10	.177	.150	.127	.110	.093
50	50	.242	.215	.192	.175	.156
	30	.189	.163	.143	.126	.109
	10	.150	.126	.106	.092	.077
30	50	.198	.175	.158	.143	.128
	30	.155	.134	.116	.103	.088
	10	.123	.102	.086	.075	.061
10	50	.157	.140	.124	.114	.101
	30	.122	.106	.091	.080	.068
	10	.096	.080	.066	.057	.045

Coefficient of Utilization

Effective Floor Cavity Reflectance 20%

% Reflectance Eff. Ceil.	% Reflectance Wall	Room Cavity Ratio				
		1	2	3	4	5
80	50	.604	.522	.454	.395	.347
	30	.576	.480	.404	.340	.290
	10	.552	.444	.364	.298	.248
70	50	.591	.512	.445	.387	.339
	30	.565	.472	.398	.336	.286
	10	.543	.440	.361	.296	.246
50	50	.564	.490	.428	.372	.327
	30	.544	.457	.387	.327	.280
	10	.526	.428	.354	.292	.245
30	50	.541	.470	.411	.358	.315
	30	.525	.444	.377	.319	.273
	10	.509	.419	.348	.288	.241
10	50	.521	.452	.396	.345	.304
	30	.507	.429	.367	.311	.268
	10	.494	.409	.342	.283	.238
% Reflectance Eff. Ceil.	% Reflectance Wall	Room Cavity Ratio				
		6	7	8	9	10
80	50	.309	.274	.244	.222	.193
	30	.253	.220	.192	.170	.142
	10	.214	.184	.155	.135	.110
70	50	.303	.270	.241	.219	.189
	30	.250	.217	.191	.168	.142
	10	.211	.181	.154	.135	.110
50	50	.291	.260	.232	.211	.184
	30	.245	.212	.186	.166	.139
	10	.209	.179	.153	.134	.109
30	50	.281	.250	.225	.204	.178
	30	.239	.209	.182	.162	.136
	10	.207	.177	.152	.133	.107
10	50	.272	.243	.217	.198	.173
	30	.234	.205	.179	.159	.134
	10	.205	.175	.150	.131	.106

Lamp: 300W/PS-30
Total Bare Lamp Lumens: 6000

Luminaire With Globe Only

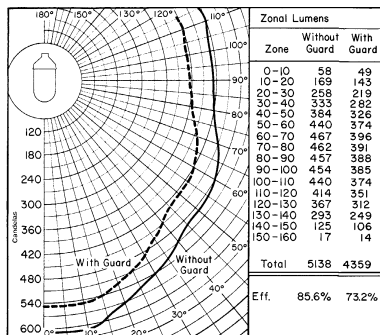

Coefficient of Utilization

Effective Floor Cavity Reflectance 20%

% Reflectance	Room Cavity Ratio					
	Eff. Ceil.	Wall	1	2	3	4
80	50	.692	.582	.499	.431	.373
	30	.644	.515	.425	.354	.300
	10	.602	.459	.367	.295	.243
70	50	.636	.534	.458	.396	.345
	30	.594	.475	.392	.327	.276
	10	.552	.425	.339	.273	.223
50	50	.532	.444	.380	.327	.286
	30	.500	.398	.328	.272	.230
	10	.470	.358	.285	.229	.188
30	50	.437	.362	.308	.264	.230
	30	.412	.326	.268	.222	.186
	10	.389	.295	.234	.186	.152
10	50	.350	.285	.241	.205	.179
	30	.331	.258	.210	.172	.144
	10	.313	.235	.183	.145	.116
% Reflectance	Room Cavity Ratio					
	Eff. Ceil.	Wall	6	7	8	9
80	50	.333	.295	.263	.238	.212
	30	.258	.223	.194	.170	.147
	10	.205	.173	.145	.125	.105
70	50	.305	.271	.241	.219	.194
	30	.238	.204	.178	.157	.136
	10	.188	.158	.133	.115	.097
50	50	.253	.224	.200	.181	.162
	30	.198	.170	.148	.131	.113
	10	.157	.132	.110	.095	.079
30	50	.204	.180	.162	.146	.130
	30	.160	.138	.119	.105	.090
	10	.127	.105	.088	.075	.061
10	50	.158	.141	.124	.114	.101
	30	.123	.106	.091	.080	.067
	10	.096	.079	.066	.055	.044

Luminaire With Globe and Dome Reflector

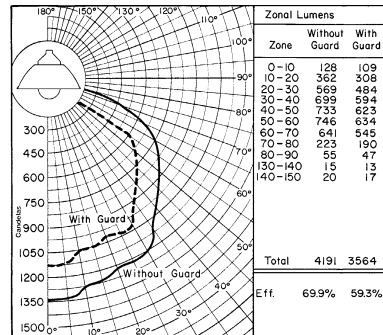

Coefficient of Utilization

Effective Floor Cavity Reflectance 20%

% Reflectance	Room Cavity Ratio					
	Eff. Ceil.	Wall	1	2	3	4
80	50	.766	.671	.587	.514	.454
	30	.734	.621	.528	.448	.385
	10	.706	.579	.482	.398	.334
70	50	.750	.657	.577	.505	.443
	30	.720	.610	.521	.444	.380
	10	.694	.573	.477	.395	.332
50	50	.717	.630	.555	.485	.429
	30	.693	.592	.507	.432	.372
	10	.672	.558	.468	.390	.329
30	50	.688	.606	.535	.468	.414
	30	.670	.575	.494	.422	.364
	10	.651	.546	.460	.385	.325
10	50	.663	.584	.516	.452	.400
	30	.647	.557	.482	.412	.357
	10	.632	.534	.452	.379	.321
% Reflectance	Room Cavity Ratio					
	Eff. Ceil.	Wall	6	7	8	9
80	50	.404	.360	.322	.293	.254
	30	.337	.294	.258	.229	.191
	10	.289	.250	.212	.185	.151
70	50	.397	.354	.317	.288	.249
	30	.333	.290	.256	.227	.191
	10	.285	.246	.211	.185	.151
50	50	.383	.342	.306	.279	.243
	30	.326	.284	.250	.223	.187
	10	.283	.244	.209	.184	.150
30	50	.371	.330	.297	.270	.235
	30	.320	.280	.245	.218	.184
	10	.281	.241	.208	.182	.148
10	50	.359	.322	.288	.262	.229
	30	.313	.275	.241	.215	.181
	10	.277	.239	.206	.180	.146

1L

Dimensions

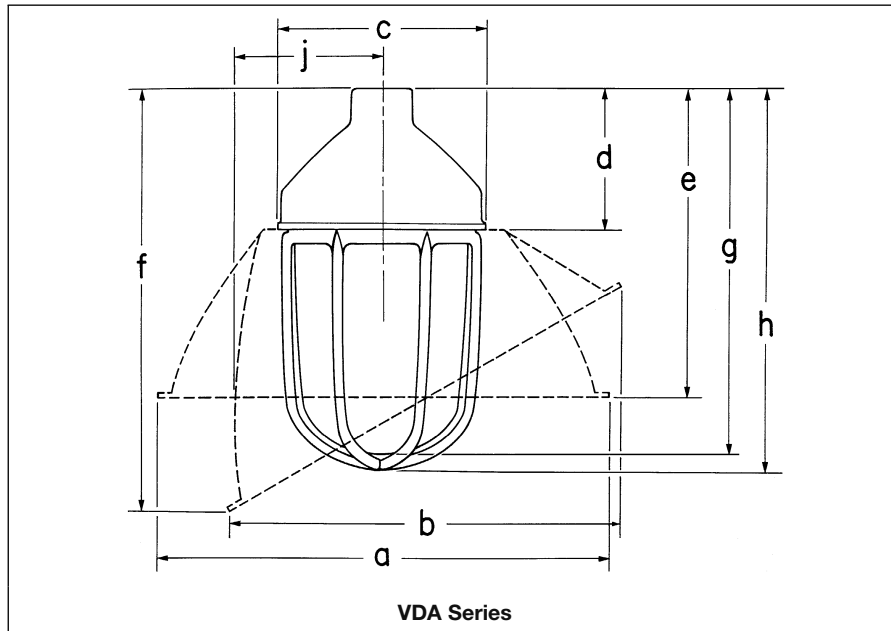

Dimensions in Inches

	150 watt, A-21	200 watt, PS-25	300 watt, PS-30
a	12 ⁷ / ₈	16 ⁵ / ₈	16 ⁷ / ₈
b	11 ¹ / ₈	14 ⁵ / ₈	14 ⁵ / ₈
c	5 ³ / ₈	6	6
d	3 ¹³ / ₁₆	4	4
e	8 ⁷ / ₁₆	9 ¹ / ₈	9 ¹ / ₈
f	12	14	14
g	8 ¹³ / ₁₆	10 ¹ / ₂	12
h	9	10 ¹³ / ₁₆	13 ¹ / ₈
j	4 ¹ / ₂	6 ¹¹ / ₁₆	6 ¹¹ / ₁₆

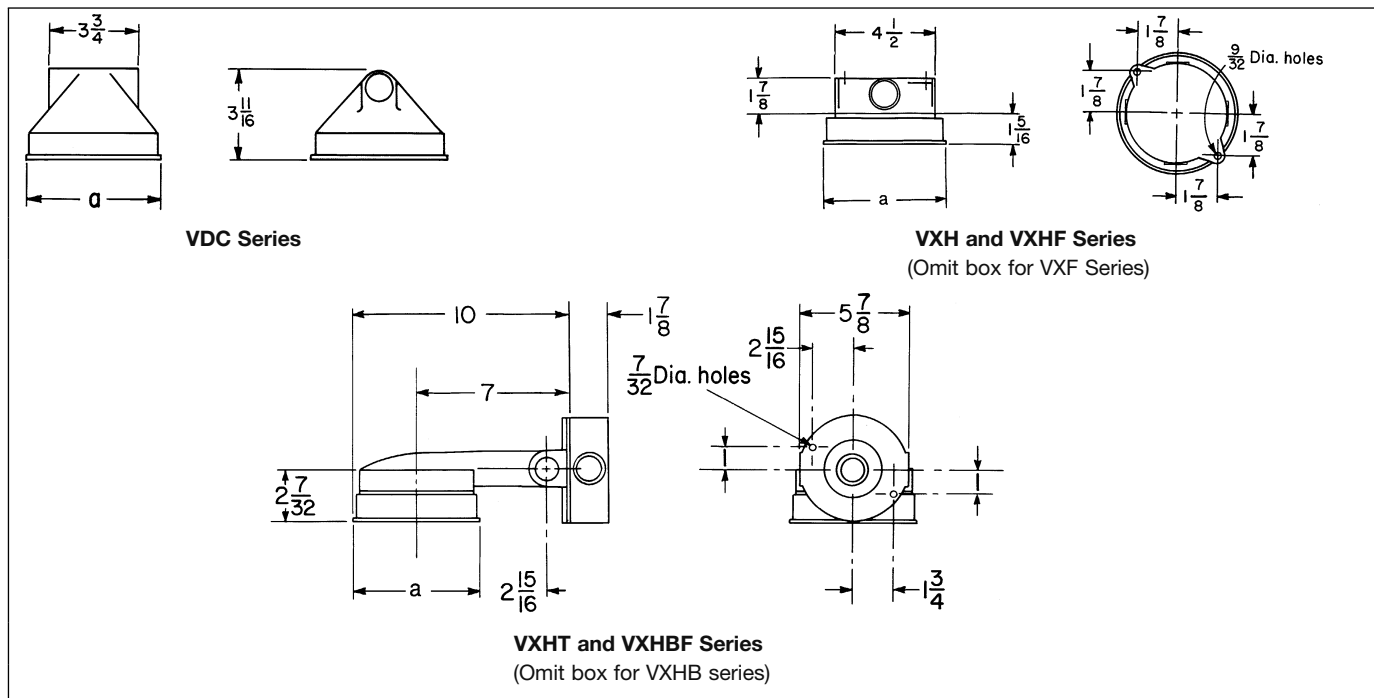

Dimensions in Inches

Max. Lamp Size	a
150 watt, A-21	5 ³ / ₈
200 watt, A-23, A-25, PS-25 and 300 watt, PS-30	6

1L V-Series Incandescent Luminaires

Wet Locations
NEMA 3, 3R

Enclosed and Gasketed

Applications:

- V-Series incandescent luminaires are used:
- Indoors or outdoors in industrial locations where enclosed and gasketed fixtures are required
 - In tunnels, building entrances and similar locations, where moisture, dirt, chemicals, vibration or rough usage are a problem
 - For flush or surface mounting on ceiling or wall, with or without a cast outlet box, pendant or in conduit systems

Features:

- Designed to exclude dirt, moisture and corrosive vapors from the interior of the fixtures and the conduit system
- Several body styles provide a wide variety of mountings, while all use the same globes, guards and optional accessories
- Rugged and corrosion resistant

Certifications and Complies:

- Wet locations
- NEMA: 3, 3R
- UL Standard: 1598

Standard Materials:

- Bodies – *Feraloy*® iron alloy
- Guards – copper-free aluminum
- Globes – glass
- Reflectors – *Krydon*® fiberglass-reinforced polyester material reflectors

Standard Finishes:

- Feraloy* iron alloy – electrogalvanized and aluminum acrylic paint
- Copper-free aluminum – natural
- Krydon*® material – high reflectance white

Options:

Description	Suffix
Corro-free™ epoxy powder coat	S752
Plastic polycarbonate globe	Order separately. See below

Size Ranges:

- ¾ hubs
- Maximum wattage lamp:
 - Glass globes 150W, A23
 - Polycarbonate 75W, A33



	VDA	VC	VG	VJ	VD
Description					
With plain globe and guard	VDA2759	VC2759	VG2759	VJ2759	VD2759
Without globe and guard	VDA275	VC275	VG275	VJ275	VD275

Glass Globes and Guards



V63



V911

Color	Cat. #	Globe Size	Cat. #
Clear (heat resisting)	V63	6¾"	V911
Green	VN72		
Blue	VN73		
Red	VN75		
Amber	VN76		

Polycarbonate Globes

Applications:

- Polycarbonate globes are used:
- In food processing plants, canneries, dairies, breweries and bakeries
 - In emergency lighting
 - Emergency police and fire alarm boxes

Features:

- Polycarbonate globes are shatterproof, preclude contamination of food products with broken particles of glass
- Comply with U.S. Dept. of Agriculture specification for food processing plants



V470

Color	Cat. #
Natural	V470
Red	V475

1L

Accessories and Parts For V-Series

Reflectors

Krydon® – fiberglass-reinforced polyester
(Must be used with V911 Guard)

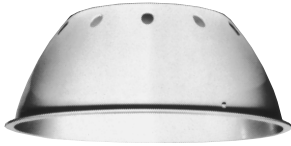

Dome



Angle

Lamp Size	Dia.	Cat. #
Dome		
50–150W	12"	RD60
30° Angle		
50–150W	12"	RA60

Note: Angle reflector cannot always be used with bracket style fixtures. Check distance from mounting surface to center of body against reflector size to determine if reflector will fit.

Receptacles (medium base)



Description	Cat. #
Medium Base Receptacle	V46

Gasket



Description	Cat. #
Gasket	GASK213

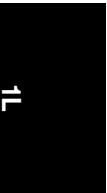

1L V-Series Incandescent Luminaires

Enclosed and Gasketed Dimensions

Dimensions In Inches:

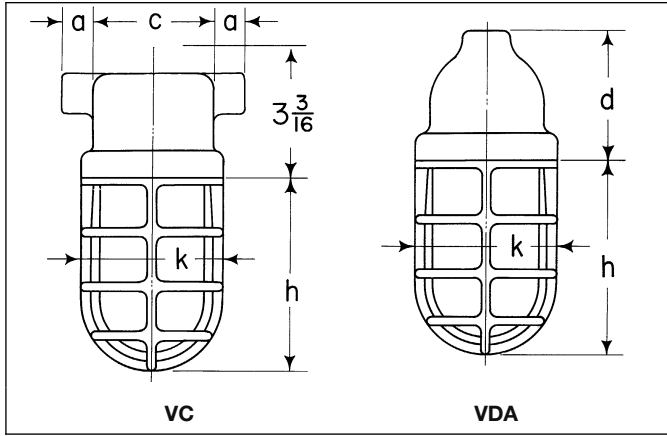

Hub Size	a	c	d	h	k
1/2	7/8	3 11/16	4	6 3/16	4 9/16
3/4	7/8	3 11/16	4	6 3/16	4 9/16

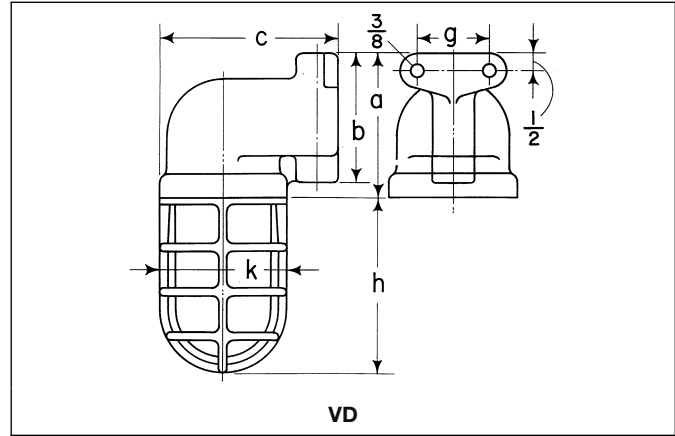

Hub Size	a	b	c	g	h	k
1/2	4 15/16	4 3/16	5 15/16	2 1/2	6 3/16	4 9/16
3/4	4 15/16	4 3/16	6 3/16	2 3/4	6 3/16	4 9/16

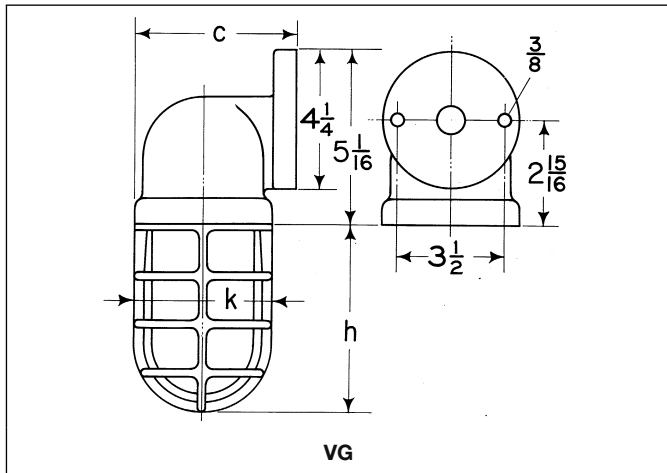

Hub Size	c	h	k
1/2	4 7/8	6 3/16	4 9/16
3/4	4 7/8	6 3/16	4 9/16

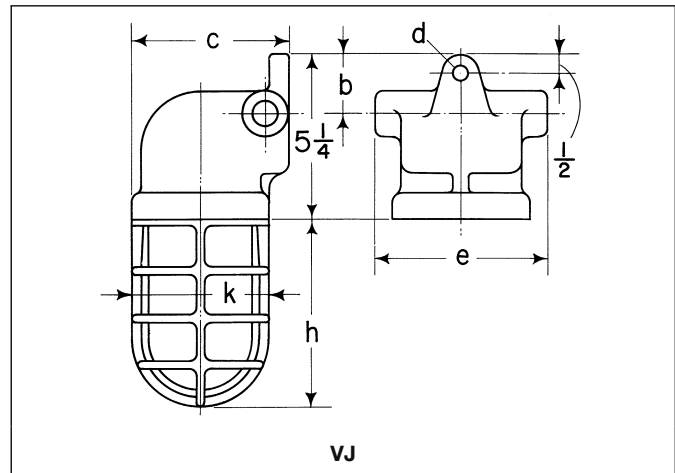

Hub Size	b	c	d	e	h	k
1/2	1 13/16	4 7/8	3/8	5 3/8	6 3/16	4 9/16
3/4	1 13/16	4 7/8	3/8	5 3/8	6 3/16	4 9/16

1L

Enclosed and Gasketed

Luminaires V-Series

Lamp: 150W/A23 Clear

Total Bare Lamp Lumens: 2800

All data provided is for 150W incandescent lamp. Use following candela/lumen multipliers for the other lamp sizes: 100W – 0.61

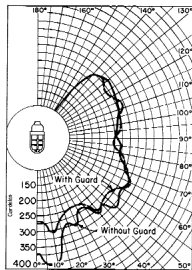

Zone	Zonal Lumens	
	Without Guard	With Guard
0-10	29	19
10-20	67	60
20-30	109	60
30-40	127	113
40-50	175	168
50-60	218	117
60-70	246	250
70-80	228	232
80-90	223	65
90-100	209	218
100-110	210	218
110-120	210	216
120-130	194	72
130-140	164	165
140-150	87	58
150-160	3	8
Total	2499	2039

Example: Zonal lumens for 150W lamp for 0-40° with guard is 252.

Coefficient of Utilization

Effective Floor Cavity Reflectance 20%

% Reflectance Eff. Ceil.	% Reflectance Wall	Room Cavity Ratio				
		1	2	3	4	5
80	50	.659	.558	.479	.416	.361
	30	.623	.504	.417	.349	.298
	10	.591	.458	.367	.298	.248
70	50	.609	.515	.442	.384	.336
	30	.577	.466	.386	.324	.275
	10	.545	.426	.342	.278	.230
50	50	.515	.434	.372	.321	.282
	30	.491	.397	.328	.274	.234
	10	.469	.364	.293	.238	.197
30	50	.429	.359	.307	.264	.232
	30	.411	.332	.274	.228	.194
	10	.395	.307	.245	.198	.165
10	50	.350	.290	.246	.211	.185
	30	.337	.269	.221	.183	.156
	10	.325	.251	.199	.160	.132

% Reflectance Eff. Ceil.	% Reflectance Wall	Room Cavity Ratio				
		6	7	8	9	10
80	50	.325	.290	.261	.236	.211
	30	.259	.227	.199	.176	.153
	10	.212	.183	.157	.136	.116
70	50	.299	.268	.241	.219	.194
	30	.240	.210	.186	.164	.143
	10	.197	.170	.146	.127	.108
50	50	.252	.226	.203	.185	.165
	30	.205	.178	.158	.140	.122
	10	.169	.145	.125	.109	.092
30	50	.208	.186	.169	.153	.137
	30	.170	.149	.131	.117	.101
	10	.141	.121	.105	.091	.076
10	50	.167	.151	.135	.124	.110
	30	.136	.121	.106	.094	.081
	10	.114	.098	.084	.073	.060

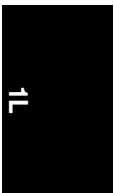

NDA Corro•Gard™ Corrosion-Resistant Incandescent Luminaires

Cl. I, Div. 2, Groups A, B, C, D
Corrosive
Wet Locations
NEMA 3, 3R, 4, 4X

Applications:

Corro•Gard™ NDA Series Luminaires made of Krydon® fiberglass-reinforced polyester are used to provide incandescent lighting:

- Indoors or outdoors in industrial wet or dirty locations and where corrosion is a problem
- In marine applications, above and below deck, where salt spray corrosion shortens fixture life
- In food and beverage industries where frequent wash-downs are necessary
- For walkways, bridges, tunnels, security lighting, cold storage facilities, garages, coal handling areas, shipboard, processing plants, and nuclear generating plant containment areas

Features:

- Luminaire is molded Krydon® for excellent corrosion, heat, and impact resistance
- Accommodates all popular incandescent lamps up to 300W, PS-25
- Attractive modern design and color complement other Corro•Gard products
- Weighs only 8½ lbs. complete with lamp and globe
- Medium screw base porcelain lamp socket has a vibration absorbing mounting bracket
- All joints are gasketed to ensure watertightness
- Configured glass globe reduces glare
- Corro•Gard reflectors made of Krydon® reflect light better than porcelainized steel; do not yellow or discolor with age; cannot chip, peel, rust or dent

Ordering Information: For Pendant Mounting

Hub Size	Max. Lamp Size	Body Only Cat. #	Globe Only Cat. #	Body With Globe Cat. #
3/4"	300W PS-25 Med. Base 120V	NDA22	G24	NDA22G

Temperature Performance Data: (based on 40°C ambient)

Max. Lamp Size	T-Number	Supply Wire (°C)
300W	T2A	150°C

Note: Fixtures are not marked with T-Number.



Dimensions In Inches:

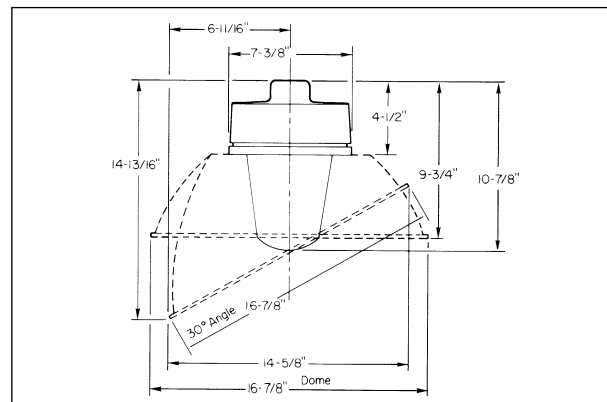

Certifications and Complies:

- UL Standard: 1598
- Wet Locations
- Suitable for 40°C ambient temperature

Standard Materials:

- Bodies and reflectors – Krydon® fiberglass-reinforced polyester material
- Globes – configured heat-resistant glass

Standard Finishes:

- Bodies – natural
- Reflectors – natural, high reflectance white

Options:

Description	Suffix
TEFLON® coating on G24 globe for increased shatter protection	S808

Accessories & Parts



Globe



Guard

Color	Globe Cat. #	Guard Cat. #
Clear (heat resisting)	G24	P21
Green	G25	
Blue	G26	
Red	G27	
Amber	G28	

Reflectors (Order separately)



Dome

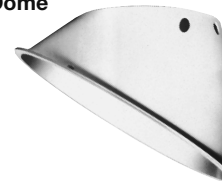

30° Angle

Type	Cat. #
Dome	RD725 (RD75)
30° Angle	RA725 (RA75)

Replacement Lamp Receptacles with Strap Shock Absorbing



Description	Cat. #
Replacement Lamp Receptacles	NV84

NDA Corro•Gard™ Corrosion-Resistant Incandescent Luminaires

Lamp: 200W/PS-25

All data provided is for incandescent with 200W/PS-25 lamp. See Multipliers for other wattages and lamp types.

Luminaire With Globe

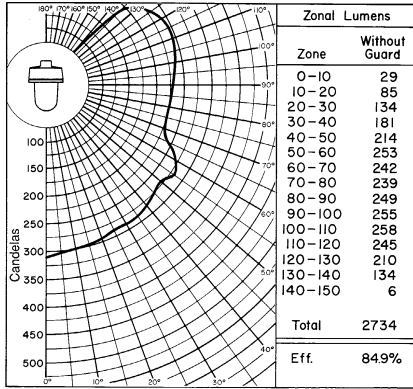

Coefficient of Utilization

Effective Floor Cavity Reflectance 20%

Eff. Ceiling	Room Cavity Ratio	% Reflectance									
		Wall 1	2	3	4	5					
80	50	.762	.651	.565	.494	.433					
	30	.715	.585	.491	.416	.358					
	10	.673	.529	.433	.357	.300					
70	50	.708	.605	.526	.461	.406					
	30	.667	.546	.460	.390	.335					
	10	.626	.496	.407	.336	.282					
50	50	.608	.519	.452	.395	.292					
	30	.576	.473	.399	.339	.250					
	10	.547	.432	.356	.295	.248					
30	50	.516	.439	.382	.335	.297					
	30	.492	.404	.342	.290	.250					
	10	.469	.372	.307	.254	.215					
10	50	.433	.366	.319	.279	.247					
	30	.413	.339	.287	.244	.211					
	10	.396	.315	.259	.215	.181					
0	0	.354	.277	.226	.184	.154					
Eff. Ceiling	Room Cavity Ratio	% Reflectance									
		Wall 6	7	8	9	10					
80	50	.389	.348	.312	.284	.253					
	30	.312	.273	.240	.214	.185					
	10	.258	.222	.190	.166	.141					
70	50	.363	.324	.291	.266	.236					
	30	.293	.256	.226	.201	.175					
	10	.242	.208	.179	.157	.133					
50	50	.312	.280	.252	.230	.205					
	30	.256	.223	.198	.177	.153					
	10	.213	.183	.158	.139	.117					
30	50	.266	.238	.216	.197	.175					
	30	.220	.193	.170	.152	.131					
	10	.185	.158	.137	.121	.100					
10	50	.223	.201	.180	.166	.147					
	30	.185	.163	.144	.129	.110					
	10	.156	.135	.116	.102	.084					
0	0	.132	.112	.096	.084	.068					

Luminaire With Globe and Dome Reflector

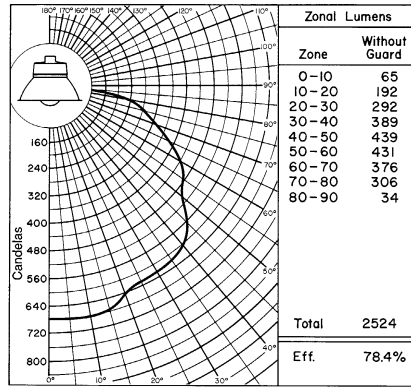

Coefficient of Utilization

Effective Floor Cavity Reflectance 20%

Eff. Ceiling	Room Cavity Ratio	% Reflectance									
		Wall 1	2	3	4	5					
80	50	.809	.703	.615	.541	.481					
	30	.773	.647	.550	.470	.408					
	10	.742	.601	.499	.416	.354					
70	50	.791	.688	.604	.531	.470					
	30	.758	.636	.542	.465	.403					
	10	.729	.595	.494	.413	.315					
50	50	.756	.659	.580	.510	.455					
	30	.729	.617	.528	.453	.395					
	10	.706	.579	.485	.408	.349					
30	50	.726	.634	.558	.492	.439					
	30	.705	.599	.514	.442	.385					
	10	.684	.566	.477	.402	.344					
10	50	.699	.610	.539	.475	.424					
	30	.663	.580	.501	.431	.378					
	10	.580	.553	.468	.396	.340					
0	0	.647	.536	.451	.378	.323					
Eff. Ceiling	Room Cavity Ratio	% Reflectance									
		Wall 6	7	8	9	10					
80	50	.431	.386	.347	.317	.277					
	30	.360	.317	.280	.250	.211					
	10	.309	.269	.231	.204	.169					
70	50	.423	.380	.342	.312	.272					
	30	.356	.312	.277	.247	.211					
	10	.305	.265	.231	.204	.169					
50	50	.408	.368	.331	.302	.265					
	30	.348	.305	.272	.243	.207					
	10	.303	.263	.229	.202	.167					
30	50	.396	.355	.321	.294	.257					
	30	.342	.301	.266	.238	.203					
	10	.300	.260	.227	.201	.165					
10	50	.383	.346	.311	.285	.250					
	30	.334	.295	.262	.235	.200					
	10	.297	.258	.225	.199	.163					
0	0	.281	.243	.210	.184	.150					

Luminaire With Globe and 30° Angle Reflector

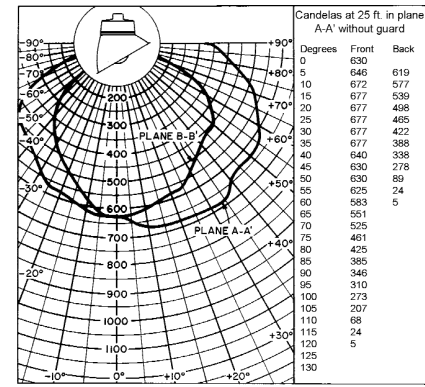

Total Lumens	Eff. %
2595	80.6



Multipliers for Other Lamps

Photometric data was developed using a 200 watt/PS-25 inside frosted incandescent lamp (3,220 lumens). For other incandescent watts/lamp size, use the following conversion factors (multipliers):

Watts	Lamp Size	Lamp Lumens	Conversion Factor
100	A-19	1750	.54
100	A-21	1690	.52
150	A-21	2880	.89
150	PS-25	2680	.83
200	A-23	4010	1.25
300	PS-25	6360	1.98

Example: Zonal lumens for 200W/PS-25 luminaire with globe and dome reflector for 30-40° is 389. Zonal lumens for 100W/A-21 luminaire with globe and dome reflector for 30-40° is 389 × .52 = 202.

1L

1L

Description	Page No.
Application/Selection	see pages 908–909
Industrial and Hazardous Area LED Luminaires	
EV LED Series	see pages 910–913
Hazard•Gard® EVLL Series	see pages 914–918
Hazard•Gard® LPL Series	see pages 919–921
LL48 Series	see pages 922–923
Champ® VMV LED Series	see pages 924–928
Champ® FMV LED Series	see pages 929–932
Vaporgard™ LED Series	see pages 933–936
N2LPS Light-Pak™ Emergency Lighting System	see pages 937–939
Ex-Lite Series LED Exit Signs	see page 940
CCH UX Series LED Exit Signs	see page 941
Champ® Pro PVM Series	see pages 943–946
Champ® Pro PFM Series	see pages 947–948
Champ® Pro PFM25L and 50L Series	see pages 949–951
Vaporgard™ Pro P2L Series	see pages 952–954
Industrial High Bay LED Series	see page 955
Endure™ LED Series	see pages 956–957
LED Obstruction Lights and Visual Signals	See Obstruction Lighting Guide



2L LED Luminaires

Application and Selection

Applications:

Luminaires included in this section are designed for use:

- In manufacturing plants; heavy industrial, chemical, petrochemical, or pharmaceutical facilities; platforms; loading docks; tunnels

Considerations for Selection:

Environmental:

- What are the hazardous areas classifications (NEC/CEC) of the locations in which the luminaires will be installed?
- Must luminaires be suitable for use in marine, hosedown, corrosive applications?

Lighting levels required:

- What wattage luminaire(s) will provide the desired light level?

Series	Application	Watts HPS, MH & Pulse Start MH Lamps	Hazardous Area & Other Environmental Suitabilities NEC, CEC, IEC
EV LED	General Illumination	26 Watts; 30 Watts; 36 Watts	NEC & CEC Cl. I, Div. 1, Groups C, D Cl. I, Zone 1 & 2, Group IIB Cl. II, Groups E, F, G Marine and Wet Locations, Type 4X, IP66 NEC Cl. III, Simultaneous Presence
Hazard•Gard EVLL LED	General Illumination	80 Watts; 100 Watts; 130 Watts; 151 Watts; 175 Watts	NEC & CEC Cl. I, Div. 1, Groups B, C, D Cl. I, Zone 1, Groups IIB + H2, IIB, IIA Cl. II, Groups E, F, G Cl. III, Simultaneous Presence
Hazard•Gard LPL LED	General Illumination	60 Watts; 85 Watts; 100 Watts; 125 Watts; 150 Watts	IEC Zones 1 and 2 (Ex-gas) Zones 21 and 22 (Ex-dust)
LL48 Linear LED	General Illumination	56 Watts	NEC Cl. I, Div. 2, Groups A, B, C, D NEMA 4X, IP66 Marine and Wet Locations
Champ® VMV LED	General Illumination	41 Watts; 67 Watts; 94 Watts; 114 Watts; 118 Watts	NEC & CEC Cl. I, Div. 2, Groups A, B, C, D Cl. I, Zone 2, nA nR Cl. II, Groups E, F, G Cl. III Simultaneous Presence Wet Locations, Type 4X, IP66
Champ® FMV LED	Outdoor/Indoor Flood Illumination	64 Watts; 89 Watts; 121 Watts; 149 Watts; 179 Watts	NEC & CEC Cl. I, Div. 2, Groups A, B, C, D Cl. I, Zone 2 Cl. II, Groups E, F, G Cl. III Simultaneous Presence Wet Locations, Type 4X, IP66
Vaporgard™ LED	Targeted Illumination	22 Watts	NEC & CEC Cl. I, Div. 2, Groups A, B, C, D Cl. II, Div. 1, Groups F, G NEMA 4X
N2LPS Light-Pak™	Emergency Illumination	Input: 9 Watts max. Lamp: 3 Watts	NEC & CEC Cl. I, Div. 2, Groups B, C, D Cl. I, Zone 2 Cl. II, Div. 1 Marine Wet Locations Suitability, Type 4X

Application and Selection

Series	Application	Watts HPS, MH & Pulse Start MH Lamps	Hazardous Area & Other Environmental Suitabilities NEC, CEC, IEC
Ex-Lite	Emergency Illumination	6 Watts	NEC & CEC Cl. I, Div. 2, Groups A, B, C, D Cl. I, Zone 1, AEx em ib IIC Cl. II, Div. 2, Groups F, G
CCH UX	Emergency Illumination	3.2 Watts	NEC Cl. I, Div. 2, Groups A, B, C, D IP65, IP66 Wet Locations NEMA 4X
Champ® Pro PVM	General High Bay/Low Bay Illumination	41 Watts; 67 Watts; 94 Watts; 114 Watts; 118 Watts	NEC & CEC UL1598 UL1598A cUL NEMA 4X IP66
Champ® Pro PFM	Outdoor/Indoor Flood Illumination	64 Watts; 89 Watts; 121 Watts; 149 Watts; 179 Watts	NEC & CEC UL1598 UL1598A cUL NEMA 4X IP66
Champ® Pro PFM 25L and 50L	Outdoor/Indoor Flood Illumination	263 Watts; 531 Watts	NEC & CEC UL1598 UL1598A cUL NEMA 4X IP66
Vaporgard™ Pro P2L	Targeted Illumination	22 Watts	NEC & CEC UL1598 UL1598A cUL NEMA 4X IP66
Industrial High Bay LED	General Illumination	141 Watts (at 120 VAC); 138 Watts (at 277 VAC)	Meets UL1598 and cUL construction requirements
Endure™ LED Wall Pack	General Illumination	27 Watts; 51 Watts	NEC & CEC UL1598 cUL IP66

2L

EV LED Series Explosionproof LED Luminaires

Factory-sealed
Improve safety, reliability and energy efficiency

Cl. I, Div. 1, Groups C, D
Cl. I, Zone 1 & 2, Group IIB
Cl. II, Groups E, F, G
Cl. III, Simultaneous Presence

UL Listed
cUL Listed (certified by UL to CSA standards)
T6 temperature rating at 55°C
Marine and wet locations
Type 4X, IP66

The enhanced EV LED product offering provides the same durability and reliability of a traditional EV incandescent or HID fixture, coupled with the low cost of ownership and energy efficiency of Eaton's Crouse-Hinds LED technology. High-performance LEDs and a solid state electronic driver provide light where you need it, at a fraction of the operating costs of HID and incandescent lighting technologies.

EV LED Series Luminaires are designed to provide durable and energy-efficient lighting in a variety of applications. Incandescent and HID general illumination models are available, along with a wildlife friendly model and optional DC input voltage.

Applications:

- Two lumen outputs for replacement of existing HID and incandescent luminaires
- Locations requiring continuous and consistent light levels in extreme ambient temperatures
- Areas requiring frequent on-and-off of lights
- Where flammable vapors, gases, ignitable dusts, fibers or flyings are present; indoors or outdoors
- Where extremely corrosive, wet, dusty, hot and/or cold conditions exist
- Type 4X, marine, wet locations and hose-down environments
- Manufacturing plants; heavy industrial, chemical, petrochemical or pharmaceutical facilities; platforms; loading docks; tunnels; outdoor wall and stanchion mounted general area lighting

Certifications & Compliances:

NEC & CEC

- Class I, Division 1, Groups C, D
- T6 temperature rating at 55°C
- Class I, Zone 1 & 2, Group IIB
- Class II, Groups E, F, G
- Marine and wet locations, Type 4X, IP66
- UL Listed
- cUL Listed (certified by UL to CSA standards)

NEC

- Class III, simultaneous presence

UL Standards

- 844 Electric Fixture Hangers for Hazardous Locations
- 1598 Luminaire
- 1598A Luminaire for Installation on Marine Vessels

CSA Standards

- C22.2 No. 137

EV LED Benefits:

Enhance safety and productivity

- Instant illumination and re-strike
- Better visibility with crisp, white light
- T6 temperature rating – safely operate in the most hazardous environments
- Cold temperature operation / no warm-up required

Reduce operation and maintenance costs

- Easy installation – compact modular fixture attaches onto existing Champ mounting module
- Energy-efficient – up to 85% reduction in energy used
- Provides up to 50,000 hours rated life – eliminates need for frequent lamp replacement
- Contains no mercury or other hazardous substances

Reliable performance in any environment

- Shock- and vibration-resistant solid-state luminaires have no filaments or glass components that could break – greatly reduces the risk of premature failure
- Operating ambient -30°C to 55°C (AC), -30°C to 40°C (DC)
- Dark sky compliant

Standard Materials:

- Body, mounting modules and guard – copper-free aluminum with Corro-free™ epoxy powder coat
- Globe – heat and impact-resistant glass
- Gaskets – silicone
- External hardware – stainless steel

Electrical Ratings:

	C201	C701	A201	C201/DC
Voltage Range	100-277V	100-277V	100-277V	10-30 VDC
Frequency	50 / 60 Hz	50 / 60 Hz	50 / 60 Hz	50 / 60 Hz
Input Power	30W	36W	36W	26W
Input Amps (Max.)	0.30A	0.36A	0.36A	2.8A
Power Factor	0.98	0.99	0.98	0.99

LED System:

- High brightness light emitting diode (LED) arrays
- Color temperature: 3000K (CRI 82) and 5600K (CRI 65) options available
- Amber color available for wildlife friendly applications
- Advanced heat sink design ensures LED does not exceed manufacturer's temperature ratings across all specified ambient conditions
- LM-79 and LM-80 reports available



EV LED Series Explosionproof LED Luminaires

Factory-sealed
Improve safety, reliability and energy efficiency

Cl. I, Div. 1, Groups C, D
 Cl. I, Zone 1 & 2, Group IIB
 Cl. II, Groups E, F, G
 Cl. III, Simultaneous Presence

UL Listed
 cUL Listed (certified by UL to CSA standards)
 T6 temperature rating at 55°C
 Marine and wet locations
 Type 4X, IP66

2L

Ordering Information:

Mounting Style	Cool Color Temperature		Warm Color Temperature		Wildlife Friendly
	C201	C701	W201	W701	A201
Luminaire Only	EVLEDC201	EVLEDC701	EVLEDW201	EVLEDW701	EVLEDA201
3/4" Pendant	EVLEDA2C201	EVLEDA2C701	EVLEDA2W201	EVLEDA2W701	EVLEDA2A201
1" Pendant	EVLEDA3C201	EVLEDA3C701	EVLEDA3W201	EVLEDA3W701	EVLEDA3A201
3/4" Ceiling Mount Thru Feed	EVLEDCX2C201	EVLEDCX2C701	EVLEDCX2W201	EVLEDCX2W701	EVLEDCX2A201
1" Ceiling Mount Thru Feed	EVLEDCX3C201	EVLEDCX3C701	EVLEDCX3W201	EVLEDCX3W701	EVLEDCX3A201
3/4" Wall Mount Thru Feed	EVLEDBX2C201	EVLEDBX2C701	EVLEDBX2W201	EVLEDBX2W701	EVLEDBX2A201
1" Wall Mount Thru Feed	EVLEDBX3C201	EVLEDBX3C701	EVLEDBX3W201	EVLEDBX3W701	EVLEDBX3A201
3/4" Bulkhead Mount	EVLEDBH2C201	EVLEDBH2C701	EVLEDBH2W201	EVLEDBH2W701	EVLEDBH2A201
1/4" Stanchion	EVLEDJ4C201	EVLEDJ4C701	EVLEDJ4W201	EVLEDJ4W701	EVLEDJ4A201

To order a fixture without a guard, remove '1' from the end of the catalog number (Example: EVLEDAC20 for 3/4" Pendant, No Guard).
 To order a fixture with 10-30VDC Input Voltage (available on 20 Series Only), add /DC to the end of the catalog number (Example: EVLEDAC201/DC).
 To order a fixture with colored inserts (available on C20 Series Only), add a "G" (for green) or "R" (for red) to the end of the catalog number (Example: EVLEDAC201G).

Family Tree:

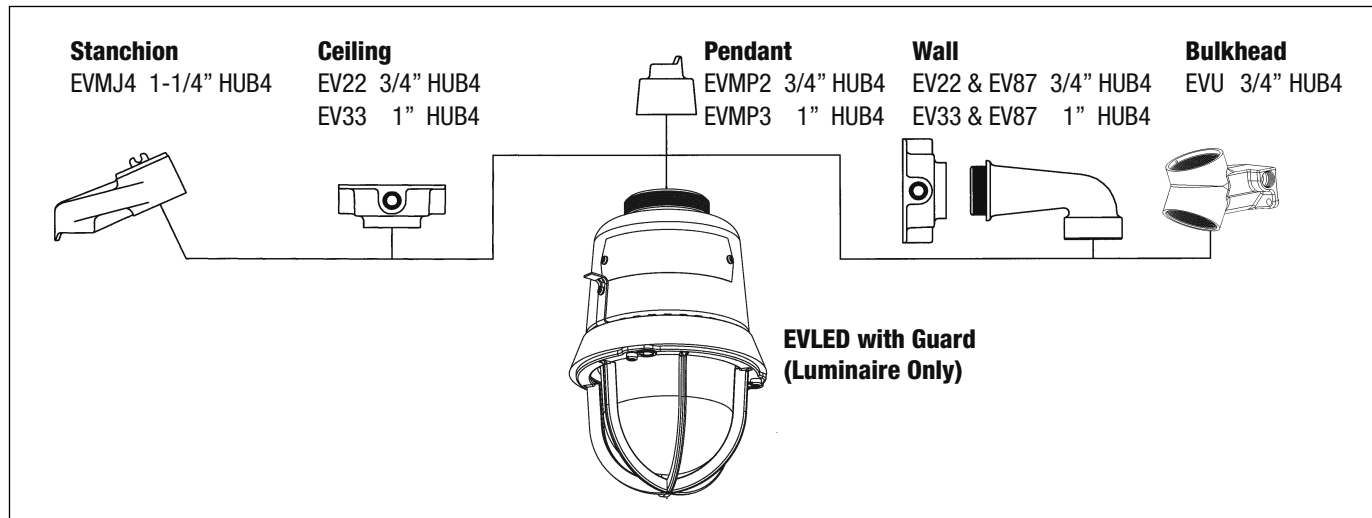

2L

2L EV LED Series Explosionproof LED Luminaires

Factory-sealed
Improve safety, reliability and energy efficiency

Cl. I, Div. 1, Groups C, D
 Cl. I, Zone 1 & 2, Group IIB
 Cl. II, Groups E, F, G
 Cl. III, Simultaneous Presence

UL Listed
 cUL Listed (certified by UL to CSA standards)
 T6 temperature rating at 55°C
 Marine and wet locations
 Type 4X, IP66

Photometrics:

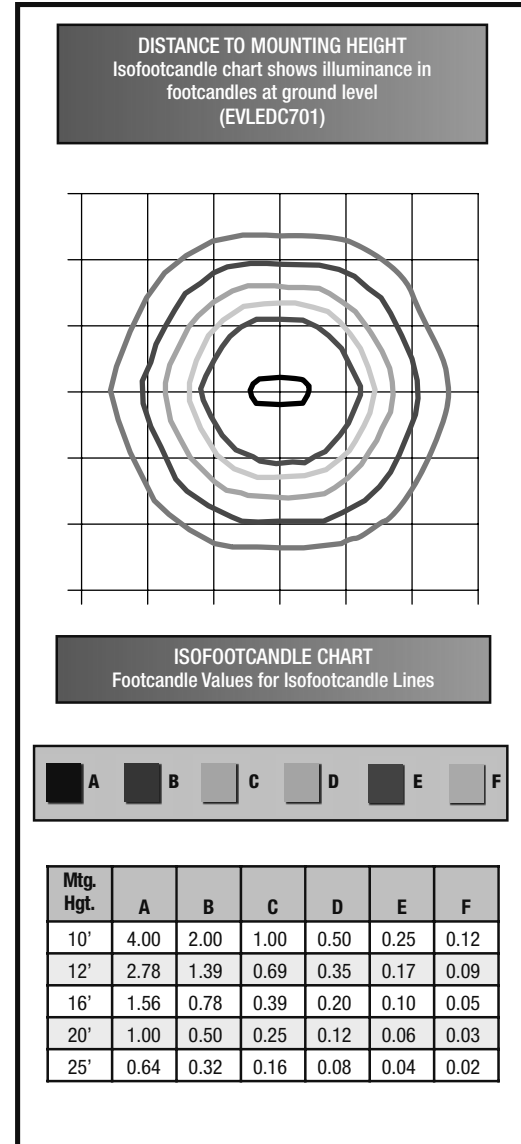
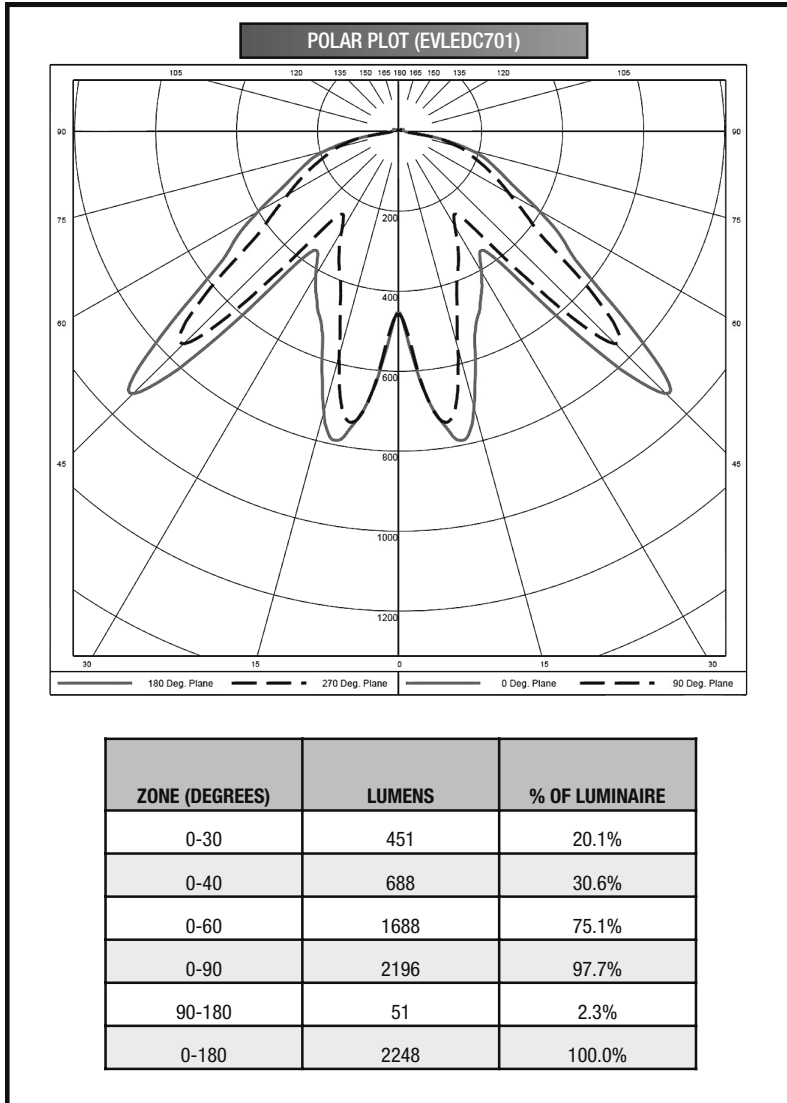

LUMEN OUTPUT FOR OTHER EV LED LUMINAIRE

Luminaire Series	System Watts	Lumens
C201	30W	1670
A201	36W	1195
C201/DC	26W	1493

2L

EV LED Series Explosionproof LED Luminaires

Factory-sealed
Improve safety, reliability and energy efficiency

Cl. I, Div. 1, Groups C, D
 Cl. I, Zone 1 & 2, Group IIB
 Cl. II, Groups E, F, G
 Cl. III, Simultaneous
 Presence

UL Listed
 cUL Listed (certified by UL to
 CSA standards)
 T6 temperature rating at 55°C
 Marine and wet locations
 Type 4X, IP66

2L

Dimensions (inches):

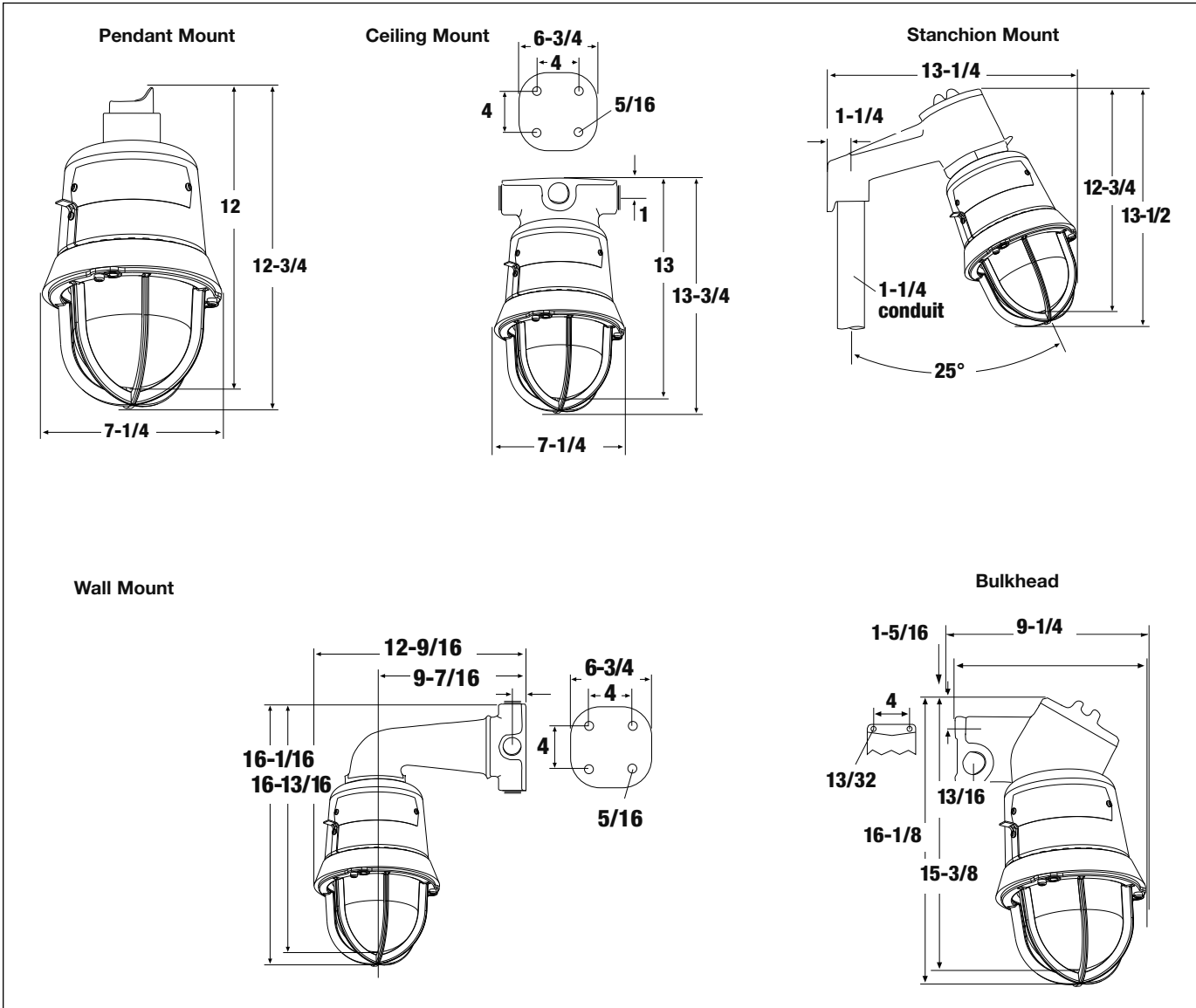

Net Weight (lbs.):

EV LED with Guard

11 lbs.

Add Mounting Modules:

Pendant

1.0 lbs.

Ceiling

2.0 lbs.

Wall

4.5 lbs.

Bulkhead

2.2 lbs.

Stanchion

2.5 lbs.



Hazard•Gard® EVLL Series Explosionproof LED Luminaires

Class I, Division 1 factory-sealed LED luminaire for general illumination

Cl. I, Div. 1, Groups B, C, D
Cl. I, Zone 1, Groups IIB + H2, IIB, IIA
Cl. II, Groups E, F, G
Cl. III

UL Listed & CSA Certified
IEC / ATEX (Pending)
Simultaneous Presence
Marine & Wet Locations
NEMA 4X, IP66

The EVLL LED Family

Hazard•Gard® EVLL Series LED Luminaires are designed to provide full-spectrum, crisp, white light. Five versions of the EVLL LED are available, providing ideal solutions for a wide range of applications.

Model	Equivalent HID Luminaire	Typical Energy Savings
EVLL5L	100W-150W MH	Up to 62%
EVLL7L	150W-175W HPS/MH	
EVLL9L	175W-250W MH	
EVLL11L	250W-400W HPS/MH	
EVLL13L	400W HPS/MH PS	

Applications:

- Five lumen outputs for replacement of existing HID luminaires
- Locations requiring continuous and consistent light levels in extreme ambient temperatures
- Areas requiring frequent on-and-off of lights
- Where flammable vapors, gases, ignitable dusts, fibers or flyings are present; indoors or outdoors
- Where extremely corrosive, wet, dusty, hot and/or cold conditions exist
- NEMA 4X, marine, wet locations, and hose-down environments
- Manufacturing plants; heavy industrial, chemical, petrochemical or pharmaceutical facilities; platforms; loading docks; tunnels; outdoor wall and stanchion mounted general area lighting

EVLL LED Benefits:

Industry best for ease of installation

- Quick-connect design – install and wire the mounting module, then simply screw in the luminaire
- Factory-sealed – no external sealing fittings required in Groups B, C, and D
- Adapter available for connection to existing Hazard•Gard® EVI, EVLP, and EVM modules

Reduce operation and maintenance costs

- Energy-efficient – up to 62% reduction in energy used versus equivalent HID fixtures
- 60,000 hours rated life – eliminates need for frequent lamp replacement

Reliable performance in any environment

- Shock- and vibration-resistant solid-state luminaires have no filaments or glass components that could break – greatly reduces the risk of premature failure
- T5 temperature rating
- Operating ambient -25°C to 65°C

Certifications and Compliances:

NEC and CEC

- Class I, Division 1, Groups B, C, D
- Class I, Zone 1, Groups IIB + H₂, IIB, IIA
- Class II, Groups E, F, G
- Class III, Simultaneous Presence

UL Standards

- UL844 Electric Fixture Hangers for Hazardous Locations
- UL1598 Luminaires
- UL1598A Luminaire for Installation on Marine Vessels

CSA Standard

- CSA C22.2 No. 137

Environmental Ratings

- NEMA 4X
- IP66
- Marine and Wet Locations

IEC and ATEX Certifications and Protection (Pending)

- Ex II 2G Ex d IIC (Zone 1, 2) (Pending)
- Ex II 2D Ex tD A21 IP66 (Zone 21, 22) (Pending)



Standard Materials:

- Body and mounting modules – copper-free aluminum with Corro-free™ epoxy powder coat
- Lens – shatter-resistant, explosionproof glass
- Gaskets – silicone
- Guard – stainless steel
- External hardware – stainless steel
- Factory-sealed*

*Refer to Installation and Maintenance Sheet for external seal requirements.

LED System:

- High brightness light emitting diode (LED) arrays
- Color temperature: 3000K (CRI 82) and 5600K (CRI 65) options available
- Advanced heat sink design ensures LED does not exceed manufacturer's temperature ratings across all specified ambient conditions
- LM-79 and LM-80 reports available

Electrical Ratings:

Model	Voltage	Input Amps (Max.)	Power Factor	Input Power	Lumen Output
EVLL5L	100-277VAC, 50 / 60 Hz 108-250VDC	0.46-0.82 0.38-0.89	0.99% 1	80W	5625
EVLL7L	100-277VAC, 50 / 60 Hz 108-250VDC	0.51-1.11 0.42-1.15	0.99% 1	100W	6750
EVLL9L	100-277VAC, 50 / 60 Hz 108-250VDC	0.61-1.19 0.56-1.30	0.99% 1	130W	9000
EVLL11L	100-277VAC, 50 / 60 Hz 108-250VDC	0.76-1.56 0.73-1.71	0.99% 1	151W	10500
EVLL13L	100-277VAC, 50 / 60 Hz 108-250VDC	0.78-1.58 0.75-1.73	0.99% 1	175W	13500

Hazard•Gard® EVLL Series Explosionproof LED Luminaires

**Class I, Division 1 factory-sealed LED
luminaire for general illumination**

Cl. I, Div. 1, Groups B, C, D
Cl. I, Zone 1, Groups IIB +
H2, IIB, IIA
Cl. II, Groups E, F, G
Cl. III

UL Listed & CSA Certified
IEC / ATEX (Pending)
Simultaneous Presence
Marine & Wet Locations
NEMA 4X, IP66

2L

Installation and replacement made simple

Modular design - This contractor-friendly design is ideal for both new construction applications and retrofit. These luminaires use the same mounting modules as existing Hazard•Gard® Series luminaires. The quick-connect design facilitates installation - install and wire the mounting module, then screw in your luminaire. Two start Acme threads ease and reduce installation time.



High efficiency and lumen output

Driver module assembly - High efficiency LED drivers are designed to provide reliable operation in even the harshest environments. Various AC and DC input voltage options are available to suit virtually any drive requirement.

Safe, reliable heat transfer

Heat sink - Enhanced heat sink design provides safe and effective heat transfer from the LED assembly to the outside environment, ensuring low LED junction temperature, reliability and sustained lumen performance.



NEMA 4X rated

LED housing assembly - The LED housing is constructed of durable die cast aluminum, providing an efficient thermal path to the heat sink assembly. The impact-resistant lens is sealed from the outside environment and provides ingress protection against water and dust. Multi-die LED arrays are used to provide energy-efficient, long-life white light.

Optional color temperatures

Warm (available on 5L through 11L models only) and cool white color temperatures available.



2L

2L

Hazard•Gard® EVLL Series Explosionproof LED Luminaires

**Class I, Division 1 factory-sealed LED
luminaire for general illumination**

Cl. I, Div. 1, Groups B, C, D
Cl. I, Zone 1, Groups IIB +
H2, IIB, IIA
Cl. II, Groups E, F, G
Cl. III

UL Listed & CSA Certified
IEC / ATEX (Pending)
Simultaneous Presence
Marine & Wet Locations
NEMA 4X, IP66

Catalog Numbering System:

SERIES	LAMP OUTPUT	LED COLOR	MOUNTING MODULE	HUB SIZE	GUARD	VOLTAGE	SUFFIXES
EVLL	5L	C	A	2	0	/UNV1	

SERIES

EVLL Explosionproof Vaportight Low Profile LED Luminaire

LAMP OUTPUT

5L 5,625 Lumen Output
7L 6,750 Lumen Output
9L 9,000 Lumen Output
11L 10,500 Lumen Output
13L 13,500 Lumen Output

LED COLOR

C Cool (5600K nominal)
W Warm (3000K nominal) (available on 5L through 11L models only)

MOUNTING MODULE

A Pendant EVSP	J Stanchion EVSJ
BX Wall Bracket EVSW	M Mounting Module Adapter EVSA (See Note #1)
CX Ceiling Mount EVSC	Blank No Mounting Module Supplied



HUB SIZE

2 ¾" NPT (Pendant, Ceiling, and Wall Only)
3 1" NPT (Pendant, Ceiling, and Wall Only)
5 1 ½" NPT (Stanchion Only)
25 25 mm (Pendant, Ceiling, and Wall Only)
32 32 mm (Pendant, Ceiling, and Wall Only)
Blank Leave Blank for Mounting Module Adapter and No Mounting Module

GUARD

0 No Guard
1 Stainless Steel

VOLTAGE (See Note #2)

/UNV1 120VAC to 277VAC 50/60 Hz, 108VDC to 250VDC

SUFFIXES

S812 Trunnion Mount

Notes:

1. EVSA Adapter for use with existing Eaton's Crouse-Hinds EVI, EVLP, and EVM mounting modules.
2. Accessory kit **EVLL347/480 K1** (step down transformer in separate enclosure) is available for 347V and 480V 60 Hz applications.

Hazard•Gard® EVLL Series Explosionproof LED Luminaires

Class I, Division 1 factory-sealed LED luminaire for general illumination

Cl. I, Div. 1, Groups B, C, D
Cl. I, Zone 1, Groups IIB + H2, IIB, IIA
Cl. II, Groups E, F, G
Cl. III

UL Listed & CSA Certified
IEC / ATEX (Pending)
Simultaneous Presence
Marine & Wet Locations
NEMA 4X, IP66

2L

Dimensions (In Inches):

Pendant Mount

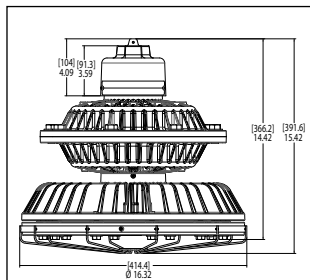

Ceiling Mount

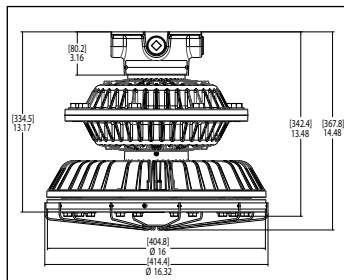

Stanchion Mount

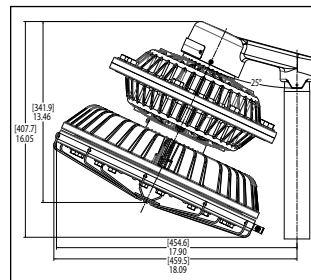

Wall Mount

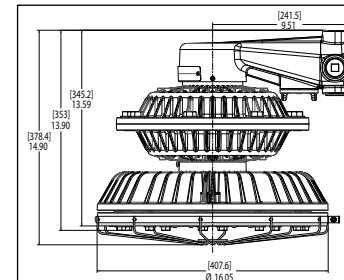

Weights:

Model	Lbs.
EVLL5L	51.76
EVLL7L	51.81
EVLL9L	52.38
EVLL11L	53.00
EVLL13L	53.00
<i>Add Mounting Modules:</i>	
Pendant	2.00
Ceiling	3.50
Stanchion	3.00
Wall	5.50
Adapter	2.00

Ambient Temperature:

Model	Max. Ambient Temp. °C	Cl. I, Div. 1	Cl. II, Div. 1 & 2 / Simu. Presence	Cl. I, Zone 1
EVLL5L	40	T6	T5	Pending
	55	T6	T5	Pending
	65	T5	T5	Pending
EVLL7L	40	T6	T5	Pending
	55	T6	T5	Pending
	65	T5	T5	Pending
EVLL9L	40	T6	T5	Pending
	55	T6	T5	Pending
	65	T5	T5	Pending
EVLL11L	40	T6	T5	Pending
	55	T6	T5	Pending
EVLL13L	40	T6	T5	Pending
	55	T6	T5	Pending

Family Tree:

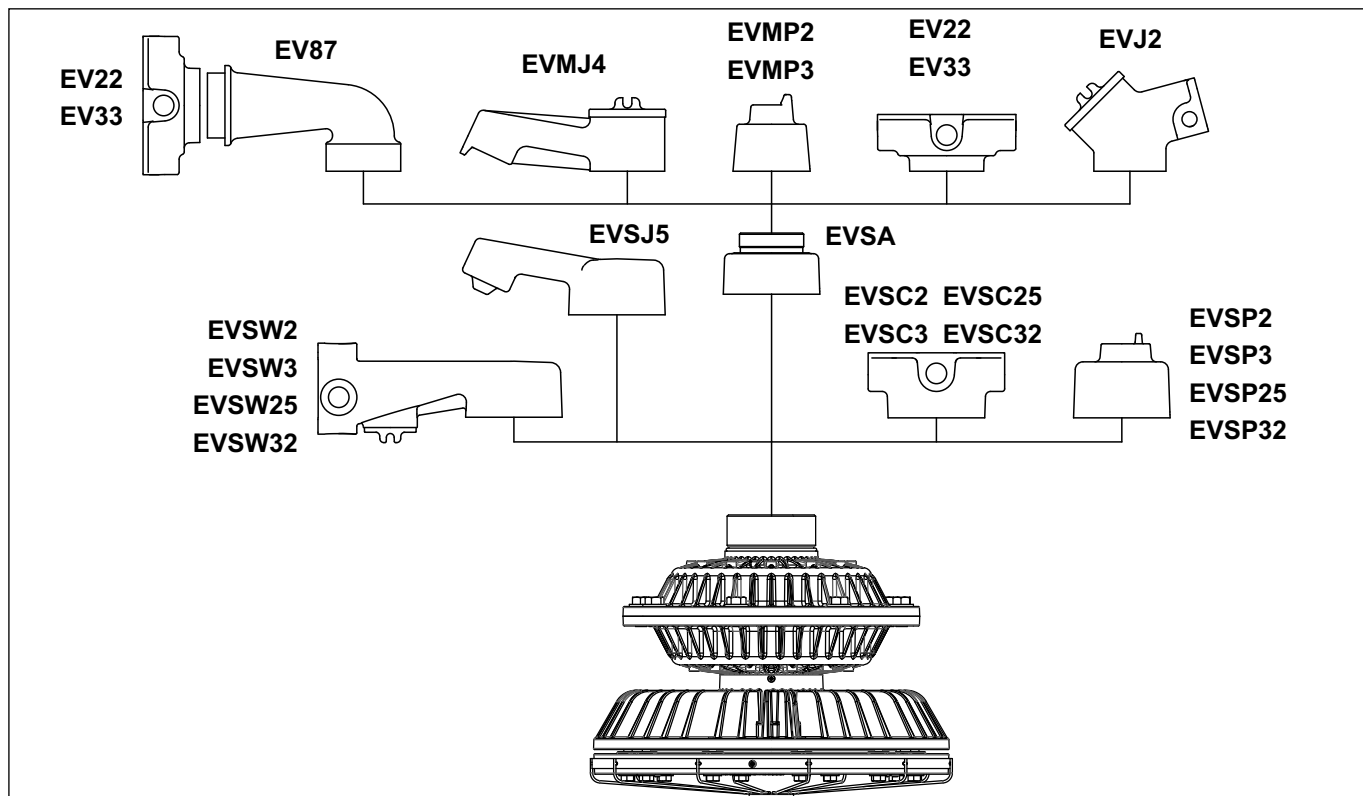

2L

Hazard•Gard® EVLL Series Explosionproof LED Luminaires

**Class I, Division 1 factory-sealed LED
luminaire for general illumination**

Cl. I, Div. 1, Groups B, C, D
Cl. I, Zone 1, Groups IIB +
H2, IIB, IIA
Cl. II, Groups E, F, G
Cl. III

UL Listed & CSA Certified
IEC / ATEX (Pending)
Simultaneous Presence
Marine & Wet Locations
NEMA 4X, IP66

Photometric Data:

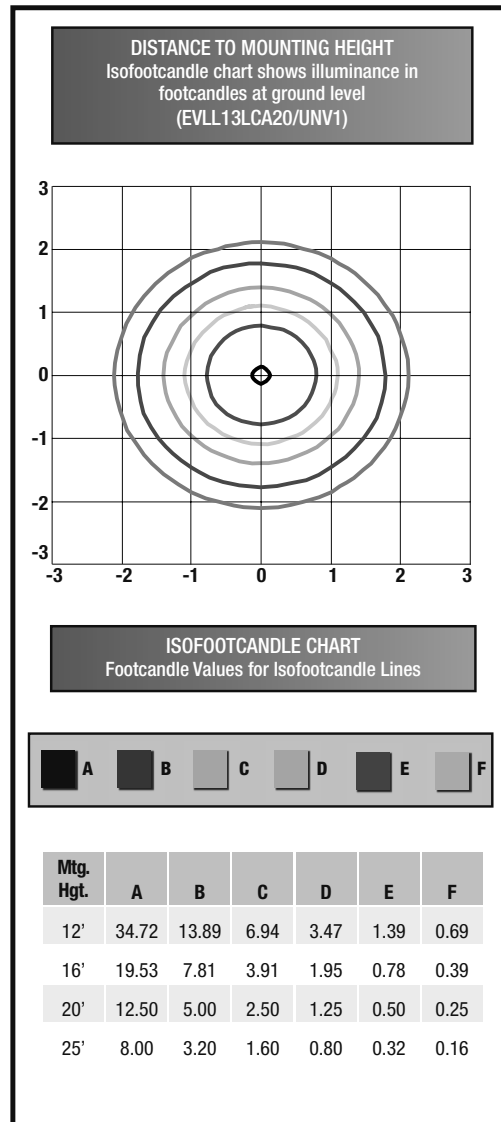
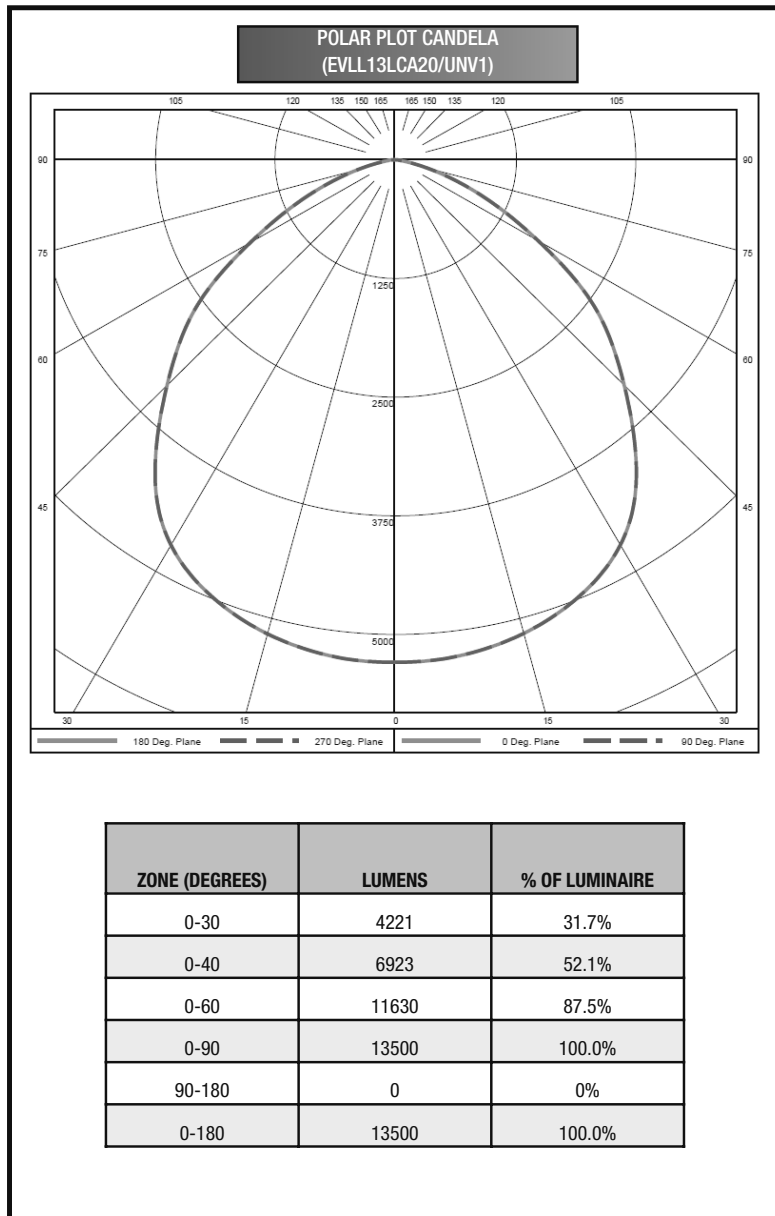

LUMEN OUTPUT FOR OTHER EVLL LED LUMINAIRES

Luminaire Series	System Watts	Lumens
EVLL5L	80W	5625
EVLL7L	100W	6750
EVLL9L	130W	9000
EVLL11L	151W	10500
EVLL13L	175W	13500

2L

Hazard•Gard® LPL Series Explosionproof LED Luminaires

Zones 1 & 2 (Ex-Gas) IECEx / ATEX
Zones 21 & 22 (Ex-Dust) IP66

2L

Zone 1 high power LED pendant for general illumination

The LPL LED Family

The LPL LED Luminaire is available in five different versions, providing ideal solutions for a wide range of applications.

Model	Equivalent HID Luminaire	Typical Energy Savings
LPL04-C60-60W	70W-100W MH	40%
LPL04-C60-85W	150W MH	
LPL04-C60-100W	175W MH	
LPL06-C60-125W	175W-250W MH	
LPL06-C60-150W	250W MH	

Applications:

- Zone 1/Zone 2 Ex-Gas and Zone 21/Zone 22 Ex-Dust hazardous areas
- Heavy industrial, chemical, petrochemical, or pharmaceutical facilities
- Offshore platforms
- Shipyards
- Electric power
- Loading docks
- Wastewater treatment plants
- Paper mills

LPL LED Benefits:

Robust construction

- Copper-free aluminum housing
- Tempered and impact-resistant glass globe, heat- and corrosion-proof
- Explosionproof design suitable for Zones 1 and 2 (Ex-Gas) and Zones 21 and 22 (Ex-Dust) hazardous areas
- Standard U-shape mounting bracket for ceiling and wall mount; pole mount accessories are available (order separately)

Reduce operation and maintenance costs

- Energy-efficient – 40% reduction in energy used versus equivalent metal halide HID luminaires
- 50,000 hours rated life – eliminates need for frequent lamp replacement

Reliable performance in any environment

- High quality LED application, shock- and vibration-resistant
- T6 temperature rating
- Operating ambient -35°C to +50°C (60W-100W models); -35°C to +40°C (125W-150W models)
- Warm white color temperature (3300K) is available for special environments, such as fog or smoke
- Lead-free and environmentally friendly
- Insulation class I

Electrical Ratings:

Model	Voltage	Power Factor	Input Power
LPL04-C60-60W	100-277VAC 50 / 60 Hz	> 0.9	60W
LPL04-C60-85W	100-277VAC 50 / 60 Hz	> 0.9	85W
LPL04-C60-100W	100-277VAC 50 / 60 Hz	> 0.9	100W
LPL06-C60-125W	100-277VAC 50 / 60 Hz	> 0.9	125W
LPL06-C60-150W	100-277VAC 50 / 60 Hz	> 0.9	150W

Specifications:

Light Angle	Cable Entry	Terminal	Permissible Ambient Temperature	
120°	2 x M25 x 1.5, 1 entry plugged	3 pole, 0.5mm ² to 6mm ² for solid wire	-35°C to +50°C	60W, 85W, 100W
			-35°C to +40°C	125W, 150W



Certifications and Compliances:

- Zones 1 and 2 (Ex-Gas)
- Zones 21 and 22 (Ex-Dust)
- Marking to 94/9/EC:
Ex II 2 GD Ex d e IIC T6 Gb
Ex II 2 GD Ex tb IIIC T80°C Db IP66
- EC-type Exam Certification: DNV 11 ATEX 06805X
- IECEx - Certificate of Conformity: IECEx-CM 12.0007X
- IP66

Standard Materials:

- Housing – copper-free aluminum
- Globe – tempered and impact-resistant glass, heat- and corrosion-proof

LED System:

- BridgeLux 10W-30W high power LED array
- Color temperature: 6000K cool white (standard); 3300K warm white (optional, for special order)
- CRI ≥ 65

2L

2L Hazard•Gard® LPL Series Explosionproof LED Luminaires

Zones 1 & 2 (Ex-Gas) IECEx / ATEX
Zones 21 & 22 (Ex-Dust) IP66

Zone 1 high power LED pendant for general illumination

Robust construction

This corrosion-proof fixture offers high quality, shock- and vibration-resistant LEDs, copper-free aluminum housing, and an impact-resistant glass globe.

Variety of mounting options

U-shape mounting bracket for ceiling and wall mount is standard. Pole mounting accessories are available and can be purchased separately.

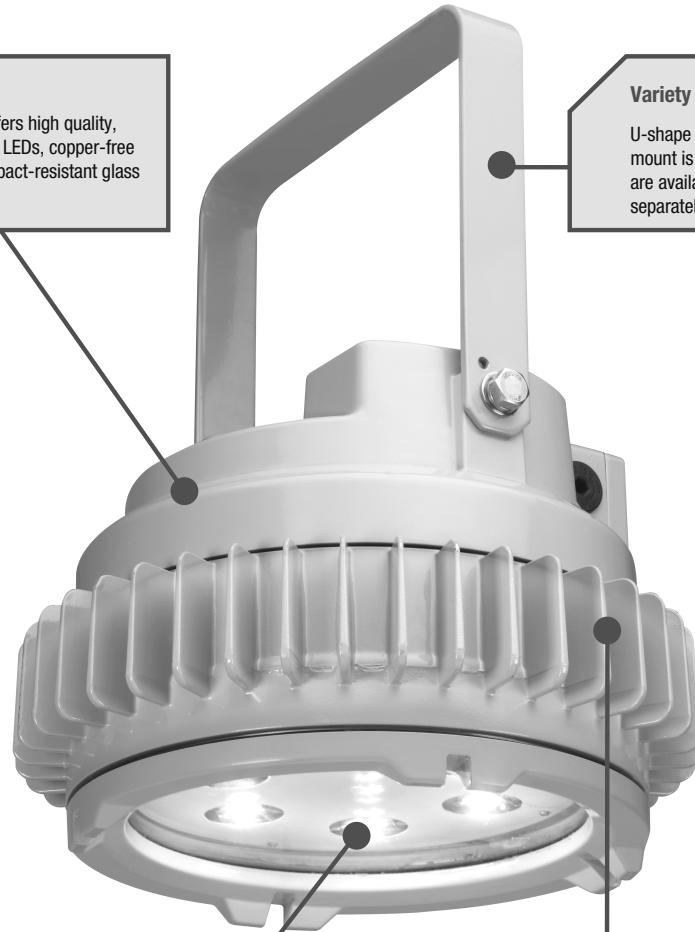

Perfect temperature and optical performance for a wide variety of applications

With a T-rating of T6, the 60W to 100W models offer a permissible temperature range of -35°C to +50°C, while the 125W and 150W models have an ambient temperature of -35°C to +40°C. Warm white (3300K) color temperature is also available for special environments, such as fog or smoke.

Excellent thermal management

Provides over 50,000 hours of life under appropriate ambient temperature.



2L

Ordering Information - Cool White Color Temperature:

Ordering Code	Product Type	Wattage	Color Temperature	Ambient Temperature
CCL1090001A	LPL04-C60-60W	60W	6000K	-35°C - +50°C
CCL1090002A	LPL04-C60-85W	85W	6000K	-35°C - +50°C
CCL1090003A	LPL04-C60-100W	100W	6000K	-35°C - +50°C
CCL1090004A	LPL06-C60-125W	125W	6000K	-35°C - +40°C
CCL1090005A	LPL06-C60-150W	150W	6000K	-35°C - +40°C

Ordering Information - Warm White Color Temperature:

Ordering Code	Product Type	Wattage	Color Temperature	Ambient Temperature
CCL1090006	LPL04-W33-60W	60W	3300K	-35°C - +50°C
CCL1090007	LPL04-W33-80W	80W	3300K	-35°C - +50°C
CCL1090008	LPL04-W33-90W	90W	3300K	-35°C - +50°C
CCL1090009	LPL06-W33-110W	110W	3300K	-35°C - +40°C
CCL1090010	LPL06-W33-130W	130W	3300K	-35°C - +40°C

Hazard•Gard® LPL Series Explosionproof LED Luminaires

Zones 1 & 2 (Ex-Gas) IECEx / ATEX
Zones 21 & 22 (Ex-Dust) IP66

2L

Zone 1 high power LED pendant for general illumination

Dimensions:

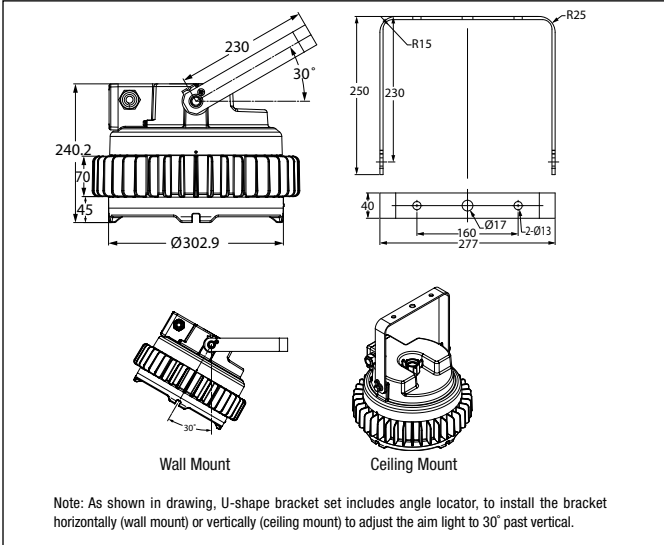

Weights:

Model	Kg.
LPL04-C60-60W	17.0
LPL04-C60-85W	17.0
LPL04-C60-100W	17.0
LPL06-C60-125W	17.0
LPL06-C60-150W	17.0

Pole Mounting Accessories (Order Separately):

Ordering Code	Product Type
CCL1076003	Please refer to below drawing for pole mounting accessories

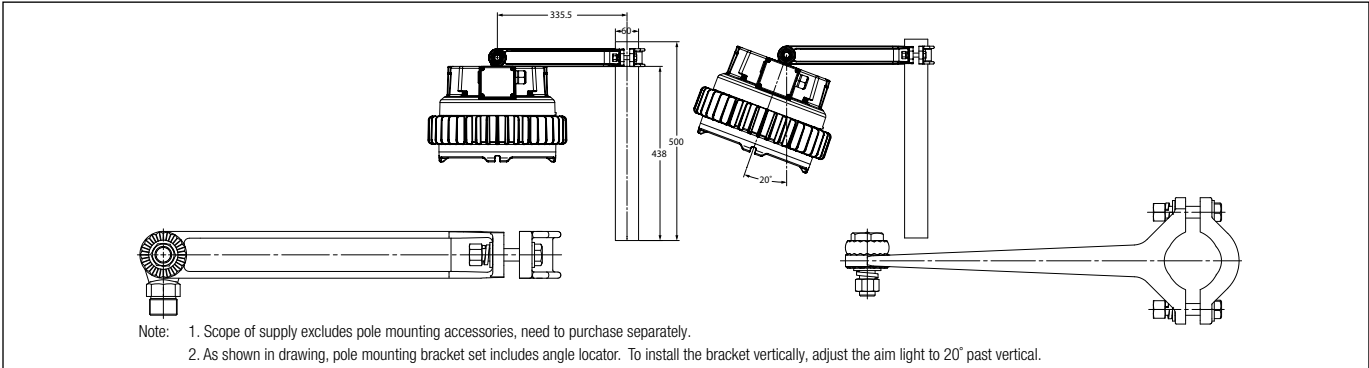

Polar Curve:

Standard 6000K, 60W Light
LPL04-C60-60W

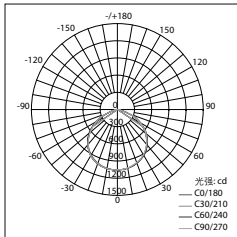

Standard 6000K, 85W Light
LPL04-C60-85W

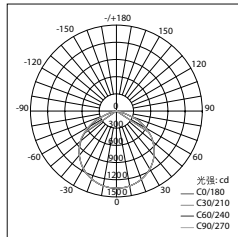

Standard 6000K, 100W Light
LPL04-C60-100W

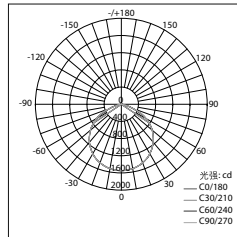

Standard 6000K, 125W Light
LPL06-C60-125W

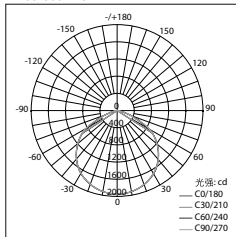

Standard 6000K, 150W Light
LPL04-C60-150W

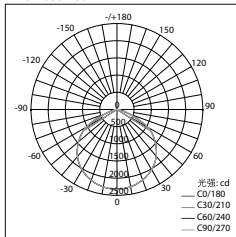

2L LL48 Linear LED Luminaires

Cl. I, Div. 2, Groups A, B, C, D NEMA 4X; IP66
 UL Listed Marine and Wet Locations
 CSA Certified

For heavy industrial applications

The LL48 Linear LED Luminaire allows for the replacement of existing harsh and hazardous industrial fluorescent fixtures and provides an energy-efficient proven light source for use in applications where reliability is critical.

Luminaire Model:

Model	Equivalent Light Output	Energy Savings
LL48	2 x 58W fluorescent light	50%

Applications:

- Used for general lighting in indoor and outdoor areas with low mounting heights or confined spaces, such as aisles, tunnels and catwalks, over doorways or entries, landing areas, utility rooms, etc.

Certifications and Compliances:

NEC Standards:

- Class I, Division 2, Groups A, B, C, D
- NEMA 4X; IP66
- Marine and Wet Locations

UL Standards:

- UL844 Electrical Fixture Hangers for Hazardous Locations
- UL1598 Luminaire
- UL1598A Luminaire for Installation on Marine Vessels

CSA Standard:

- C22.2 No. 137

Standard Materials:

- Housing – copper-free aluminum with Corro-free™ epoxy powder coat end caps and extruded aluminum body
- Lens – heat- and impact-resistant glass
- External hardware – stainless steel

Electrical Ratings:

- 100VAC to 277VAC 50 / 60 Hz
- Power factor >0.9

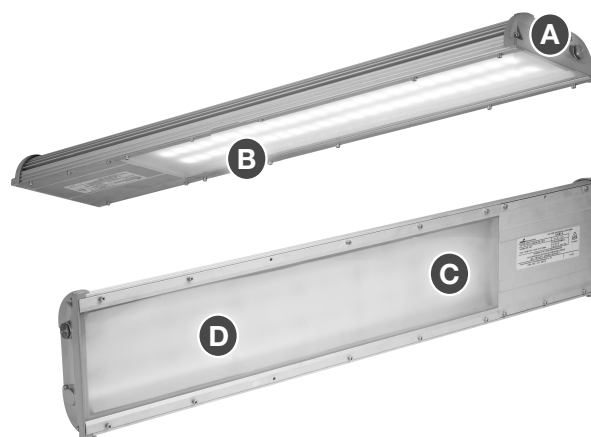

Design Features:

- Ⓐ Luminaire is designed to match the footprint of a traditional linear fluorescent fixture.
- Ⓑ Same light pattern and lumen output at a fraction of the energy cost.
- Ⓒ Diffused lens reduces glare.
- Ⓓ Shock- and vibration-resistant LEDs contain no mercury, eliminating costly lamp disposal programs.

Additional Features and Benefits:

Best-in-class reliability

- Linear LED solution can withstand extreme vibration that would cause traditional technologies to fail
- Can handle temperature extremes down to -35°C where comparable products cannot operate
- Redundant drivers housed next to LED arrays for slim profile and superior heat dissipation
- Redundant drivers and LED modules ensure the highest factor of safety in the industry

Versatile mounting options

- Ceiling mount standard (included with fixture)
- Choice of brackets for wall or pole mounting (ordered separately); can be mounted in any position to maintain ratings
- Luminaire uses the same mounts as eLLK/nLLK Series

Reliable performance in any environment

- T5 at 40°C, T4A at 55°C temperature ratings
- Operating temperature range: -35°C to +55°C

Ordering Information:

Cat. #	System Power	Glass Color	Entry	Lumen Output	CCT
LL48-60W-765/-F-1M	56W	Frosted	M20	3716	Cool White, 6500K
LL48-60W-765/-C-1M	56W	Clear	M20	4380	Cool White, 6500K
LL48-60W-765/-F-1N	56W	Frosted	1/2" NPT	3716	Cool White, 6500K
LL48-60W-765/-C-1N	56W	Clear	1/2" NPT	4380	Cool White, 6500K

2L

LL48 Linear LED Luminaires

Cl. I, Div. 2, Groups A, B, C, D NEMA 4X; IP66
 UL Listed Marine and Wet Locations
 CSA Certified

2L

For heavy industrial applications

Dimensions:

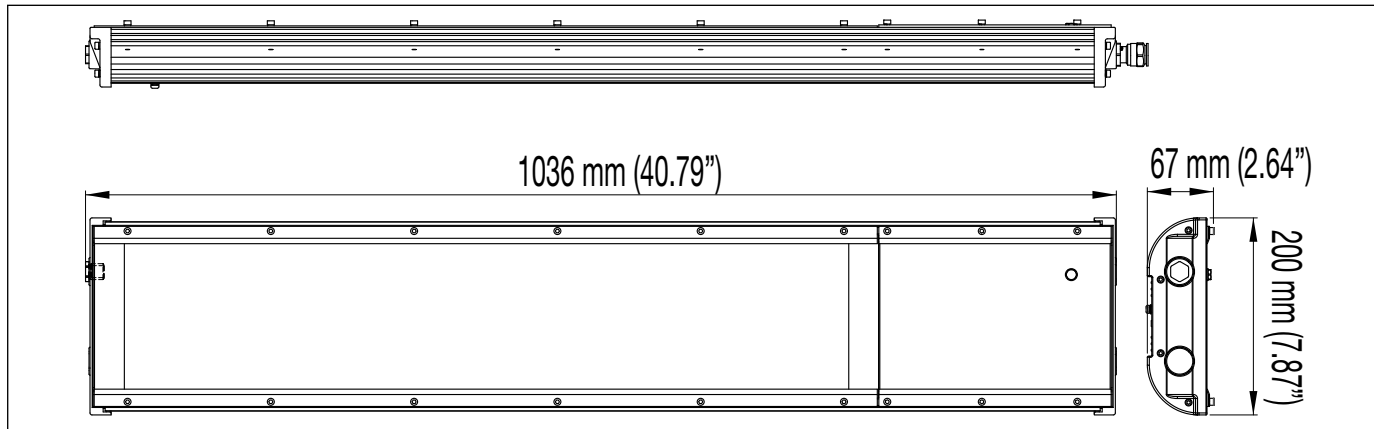

Mounting Styles:

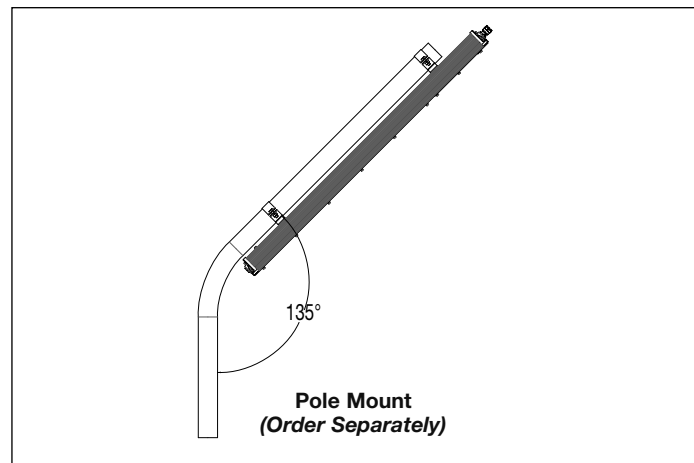
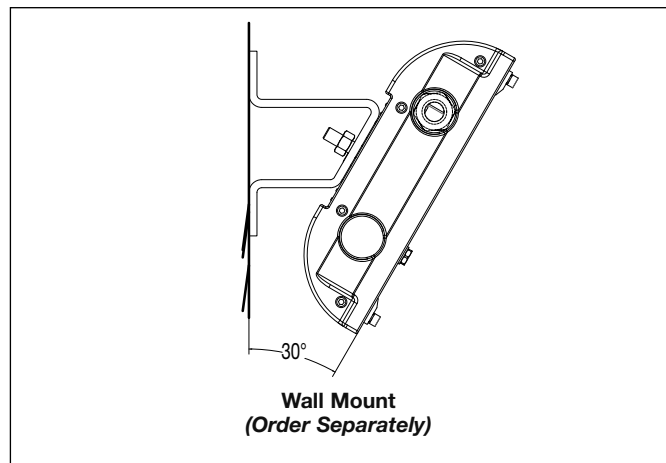
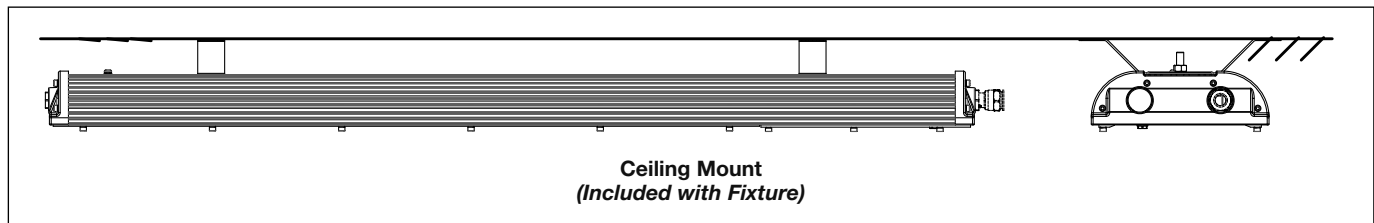

2L

Mounting Ordering Information:

Cat. #	Description
12329778	Ceiling Mounting Bracket Kit
12329779	Clamp for Pole Mounting 1 1/4" Kit
12329900	Clamp for Pole Mounting 1 1/2" Kit
12329901	Clamp for Pole Mounting 2" Kit
12329902	Luminaire Wall Suspension 27° Kit
12329903	Luminaire Wall Suspension 30° Kit

Photometrics:

- LM79 data available upon request

Champ® VMV LED Series Luminaires

Improve safety, reliability and
energy efficiency

Cl. I, Div. 2, Groups A, B, C, D
Cl. I, Zone 2
Cl. II, Groups E, F, G
Cl. III

UL / cUL Listed
IECEX / ATEX
Simultaneous Presence
Wet Locations, Type 4X, IP66

The Champ VMV LED Family

VMV LED Series Luminaires are designed to provide full-spectrum, crisp, white light with custom IES Type I, III and V distribution. Five versions of the Champ VMV LED are available, providing ideal solutions for a wide range of applications.

Model	Nominal† Lumens (Type V)	Wattage	Equivalent HID Luminaire	Typical Energy Savings / Lifetime
VMV3L	3,515	41	70W-100W	Up to 77%
VMV5L	5,288	67	100W-150W	Up to 67%
VMV7L	7,404	94	150W-175W	Up to 67%
VMV9L	9,515	114	250W-400W	Up to 74%
VMV11L	10,935	118	400W	Up to 74%

†Tolerance +/- 10%.

Applications:

- Locations requiring continuous and consistent light levels in extreme ambient temperatures
- Areas requiring frequent on-and-off of lights
- Where flammable vapors, gases, ignitable dusts, fibers or flyings are present; indoors or outdoors
- Where extremely corrosive, wet, dusty, hot and/or cold conditions exist
- Manufacturing plants; heavy industrial, chemical, petrochemical or pharmaceutical facilities; food and beverage facilities; mining; platforms; loading docks; tunnels; indoor/outdoor spot lighting; outdoor wall and stanchion mounted general area lighting

Champ VMV LED Benefits:

- Instant illumination and restrike
- Better visibility with crisp, white light
- Cold temperature operation / no warm-up required
- Redundancy in drivers with multiple series circuits connected to each driver to avoid complete loss of illumination
- Easy installation – compact modular fixture attaches onto existing Champ mounting module
- Energy-efficient technology – up to 77% energy savings over HID fixtures
- Provides up to 60,000 hours rated life and up to 170,000 hours of economic life – eliminates need for frequent lamp replacement
- Contains no mercury or other hazardous substances
- Shock- and vibration-resistant solid-state luminaires have no filaments or glass components that could break – greatly reduces the risk of premature failure
- Operating ambient -40°C to 55°C
- Dark sky compliant
- 5 year fixture warranty†

†Refer to page 2 of the D-0413 authorized distributor price book for Eaton's Crouse-Hinds standard Terms and Conditions.

Certifications and Compliances:

- DesignLights Consortium® pending for select models*

NEC and CEC

- Class I, Division 2, Groups A, B, C, D
- Class I, Zone 2, nA nR
- Class II, Groups E, F, G
- Class III
- Zone 21 tb
- Simultaneous Presence
- Wet Locations, Type 4X, IP66

UL Standards

- UL844
- UL1598 Luminaires, UL1598A Marine

CSA Standard

- cUL Listed to CSA Standard CSA C22.2 No. 137

IECEX/ATEX Standards

- IEC60079-0:2011/EN60079-0:2012
- IEC60079-15:2010/EN60079-15:2010
- IEC60079-31:2008/EN60079-31:2009
- IEC60529:2001/EN60529:2001
- IEC60598-1:2008/EN60598-1:2008
- IEC60598-2:2008/EN60598-2:2008
- IECEX UL 13.0052X
- DEMKO 13 ATEX 1305741X
- DEMKO 13 ATEX 1475013X**
- CE

100-277 VAC / 108-250 VDC

- Ex nA nR IIC T6 Gc -40°C to +40°C
- Ex nA nR IIC T5 Gc -40°C to +55°C
- Ex tb IIIC T72°C Db IP66 -40°C to +40°C
- Ex tb IIIC T87°C Db IP66 -40°C to +55°C
- Ⓢ II 3 G Ex nA nR IIC T6 Gc -40°C to +40°C**
- Ⓢ II 3 G Ex nA nR IIC T5 Gc -40°C to +55°C**
- Ⓢ II 2 D Ex tb IIIC T72°C Db IP66 -40°C to +40°C
- Ⓢ II 2 D Ex tb IIIC T87°C Db IP66 -40°C to +55°C

347-480 VAC

- Ex nA nR IIC T4 Gc -40°C to +55°C
- Ex tb IIIC T70°C Db IP66 -40°C to +40°C
- Ex tb IIIC T85°C Db IP66 -40°C to +55°C
- Ⓢ II 3 G Ex nA nR IIC T4 Gc -40°C to +55°C**
- Ⓢ II 2 D Ex tb IIIC T70°C Db IP66 -40°C to +40°C
- Ⓢ II 2 D Ex tb IIIC T85°C Db IP66 -40°C to +55°C

*Cool white 120-277 VAC 3L-11L models. Refer to page 2 of the D-0413 authorized distributor price book for Eaton's Crouse-Hinds standard Terms and Conditions.



Standard Materials:

- Lamp housing and adapter – die cast aluminum with Corro-free™ epoxy powder coat
- Lens – heat- and impact-resistant glass
- Gaskets – silicone
- External hardware – stainless steel
- Factory-sealed, no external seals required

LED System:

- High intensity discrete power emitters
- Cool white (5000K, 70 CRI) and warm white (3000K, 80 CRI)
- Custom optics designed to go over each discrete LED

Custom Optics:

Three optical options to maximize light distribution and intensity:

TYPE I

Ideal for:

- Mining conveyor belts
- Aisleways and hallways
- Catwalks and walkways
- Ramps and loading docks
- Tunnels with overhead mounts

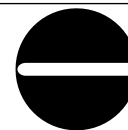

TYPE III

Ideal for:

- Narrow crosswalks or passages with wall mounted fixtures
- Tunnels with wall mount
- Wall or stanchion mount requiring 180° forward throw beam patterns



TYPE V

Ideal for:

- Pendant, ceiling or stanchion mount overhead building mounts
- Processing mills, industrial plants, large buildings, warehouses, etc.



Crouse-Hinds
by **E.T.N**

Champ® VMV LED Series Luminaires

Improve safety, reliability and energy efficiency

Cl. I, Div. 2, Groups A, B, C, D
Cl. I, Zone 2
Cl. II, Groups E, F, G
Cl. III

UL / cUL Listed
IECEX / ATEX
Simultaneous Presence
Wet Locations, Type 4X,
IP66

2L

Drivers:

Option	3L - 11L
/UNV1	120-277 VAC, 50 / 60 Hz
/UNV34**	347-480 VAC, 50 / 60 Hz
/VDC‡	108-250 VDC, 50 / 60 Hz

**No separate external transformer required to step down voltage.

‡Separate driver for DC applications.

Electrical Ratings:

	VMV3L	VMV5L	VMV7L	VMV9L	VMV11L
Voltage Range, VAC	120-277	120-277	120-277	120-277	120-277
Frequency	50 / 60 Hz	50 / 60 Hz	50 / 60 Hz	50 / 60 Hz	50 / 60 Hz
Input Power (Watts)	41	67	94	114	118
Input Amps at 120-277 VAC	0.34-0.17	0.57-0.29	0.80-0.42	0.96-0.49	0.96-0.49
Voltage Range, VDC	108-250	108-250	108-250	108-250	108-250
Power Factor	>0.90	>0.90	>0.90	>0.90	>0.90
Nominal Lumens† (Type V)	3,515	5,288	7,404	9,515	10,935

†Tolerance +/- 10%.

Design Features:

- Ⓐ Installation and replacement made simple - this contractor-friendly, modular design is ideal for both retrofit and new construction applications. These luminaires are installed in the same manner and use the same mounting modules as existing Champ® Series luminaires. The compact modular design of the VMVL allows for easy component replacement and future upgrade.
- Ⓑ High efficiency and lumen output - custom high efficiency LED drivers are designed to provide reliable operation in even the harshest environments. Various AC and DC input voltage options are available to suit virtually any drive requirement.
- Ⓒ Safe, reliable heat transfer - die cast aluminum housing provides safe and effective heat transfer from the LED assembly to the outside environment, ensuring low LED junction temperature, reliability, and sustained lumen performance. The vertical fin design facilitates air flow and dust shedding. The impact-resistant lens is sealed from the outside environment and provides ingress protection against water and dust.
- Ⓓ Custom optics - custom optics designed for discrete LED power emitters.
- Ⓔ Ease of wiring and installation - available with lever lock connectors and standard three-pole terminal block for ease of wiring and installation.



Custom Optics:

Custom optics designed for discrete LED power emitters:

- Type V standard
- Type I and Type III optional



Type I



Type III

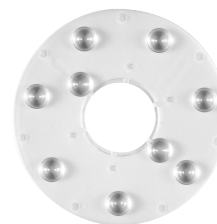

Type V

Colored LED Options:

- Available in red, blue, green and amber
- Reduction in light pollution for night space observation and sky glow due to isolating blue wavelength in red and amber colors
- Wildlife friendly
- Improves visibility for telescopes in observatories during night sky space exploration

Crouse-Hinds
by E.T.N

2L

2L

Champ® VMV LED Series Luminaires

Improve safety, reliability
and energy efficiency

Cl. I, Div. 2, Groups A, B, C, D
Cl. I, Zone 2
Cl. II, Groups E, F, G
Cl. III

UL / cUL Listed
IECEX / ATEX
Simultaneous Presence
Wet Locations, Type 4X, IP66

Catalog Numbering System:

VMV 7L W 2A R1 G /UNV1 S890

Lamp/Function	
3L	3,515 Lumen LED
5L	5,288 Lumen LED
7L	7,404 Lumen LED
9L	9,519 Lumen LED
11L	10,935 Lumen LED
RL	Red (3,200 Lumen)
GL	Green (4,300 Lumen)
BL	Blue (2,100 Lumen)
AL	Amber (5,000 Lumen)

Color Temperature	
BLANK	Cool (5000 ± 200K)
W	Warm (3000K ± 200K)

Guard	
BLANK	No Guard
G	P3001 Wire Guard

Voltage	
/UNV1	120-277 VAC, 50/60 Hz
/UNV34	347-480 VAC, 50/60 Hz
/VDC	108-250 VDC, 50/60 Hz

Suffixes	
S812	Trunnion Mount Kit with Pin
S890	Quick Clip
S891	Diffused Lens†
S896	Teflon Coated Lens†
S903	Polycarbonate Lens
TB6	Six-pole Terminal Block†

Mounting Style	
BLANK	No Cover
J	1-½" Stanchion 25°
P	1-½" Stanchion Straight
2A	¾" Pendant
3A	1" Pendant
2B	¾" Cone Pendant
3B	1" Cone Pendant
2C	¾" Ceiling
3C	1" Ceiling
2HA	¾" Flexible Pendant
2TW	¾" Wall
3TW	1" Wall

Optics	
BLANK	Type V Optic Standard (All Mounts)
R1	Type I Optic (All Mounts Minus Ceiling)
R1A	Type I Optic (Ceiling with Conduit 45° Counterclockwise or 135° Clockwise from Hinge)*
R1B	Type I Optic (Ceiling with Conduit 45° Clockwise or 135° Counterclockwise from Hinge)*
R3	Type III Optic (All Mounts Minus Ceiling)
R3A1	Type III Optic (Ceiling with Conduit 45° Counterclockwise from Top Hat Hinge)**
R3A2	Type III Optic (Ceiling with Conduit 135° Clockwise from Top Hat Hinge)**
R3B1	Type III Optic (Ceiling with Conduit 45° Clockwise from Top Hat Hinge)**
R3B2	Type III Optic (Ceiling with Conduit 135° Counterclockwise from Top Hat Hinge)**

*For new construction, order R1A only.
**For new construction, order R3A1 only.
†Not available for IEC applications.

2L

Options:

Description

Wire guard with captive mounting hardware	P3001
Trunnion mount with redundant pin locking mechanism (ceiling mount required)	S812 K1
Quick Clip for quick installation	S890
Diffused lens for glare reduction‡	S891
Teflon coating on lens for additional shatter protection‡	S896
Polycarbonate lens available in applications where glass is prohibited	S903
Six-pole terminal block‡	TB6

‡Not available for IEC applications.

Accessories (Ordered Separately):

Description

Photocell, 120V, 50 / 60 Hz	D2S20
Photocell, 208-277V	D2S208 277
Occupancy sensor, ½" entry, 120 / 277 VAC***	COS1/UNV1
Occupancy sensor, ¾" entry, 120 / 277 VAC***	COS2/UNV1
Occupancy sensor, 1" entry, 120 / 277 VAC***	COS3/UNV1

***For 347-480 VAC, replace /UNV1 with /UNV34.

Champ® VMV LED Series Luminaires

Improve safety, reliability
and energy efficiency

Cl. I, Div. 2, Groups A, B, C, D
Cl. I, Zone 2
Cl. II, Groups E, F, G
Cl. III

UL / cUL Listed
IECEX / ATEX
Simultaneous Presence
Wet Locations, Type 4X, IP66

2L

Dimensions:

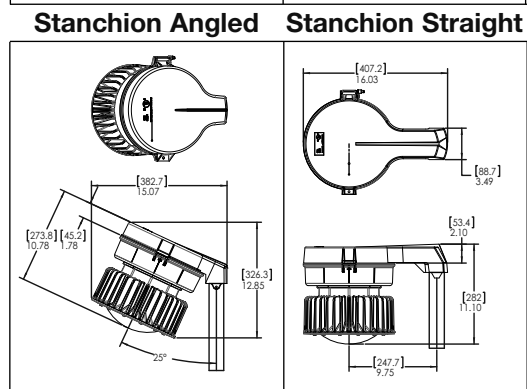
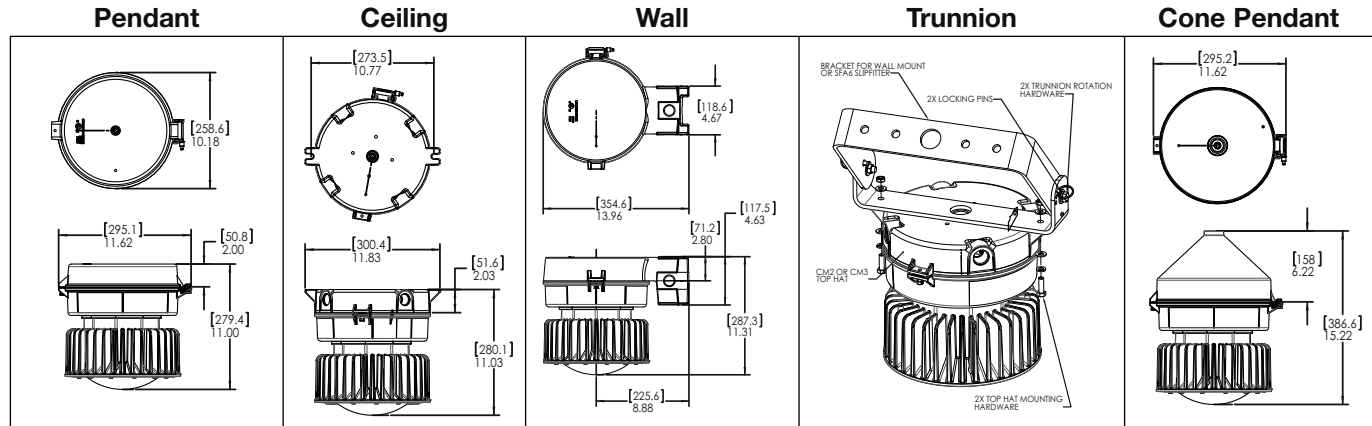

Weights:

Net Luminaire Weight:	21.8 lbs.	8.07 kg.
Mounting Module add (lb.)		
Pendant	1.25	0.57
Cone Pendant	4.00	1.81
Flexible Pendant	1.50	0.68
Ceiling	2.75	1.25
Wall	4.50	2.04
Angle Stanchion	3.50	1.59
Straight Stanchion	4.50	2.04

Temperature Codes:

Model	Driver Type	Ambient	Cl. I, Div. 2 / Zone 2, nA, nR	Cl. II, Div. 1	Sim. Pres. / Cl. I, Div. 2 / Cl. II, Div. 1	Zone 21
3L, 5L, 7L, 9L, 11L‡	/UNV1 (100-277 VAC)	40°C	T6	T5	T3C	T72
	/VDC (108-250 VDC)	55°C	T5	T4A	T3B	T87
	/UNV34 (347-480 VAC)	40°C	T4	T5	T3C	T70
		55°C	T4	T4A	T3A	T85
RL, GL, BL, AL	/UNV1 (100-277 VAC)	40°C	T5	T6	T4A	T60
		55°C	T4	T6	T4A	T75

‡Teflon and diffused glass options are only NEC certified for: Class I, Division 2/Sim. Pres. - T3C (40°C); T3B (55°C) for /UNV1 and /VDC, and T3C (40°C); T3A (55°C) for /UNV34. Class II, Division 1 - T5 (40°C); T4A (55°C) for /UNV1, /VDC and /UNV34.

Family Tree:

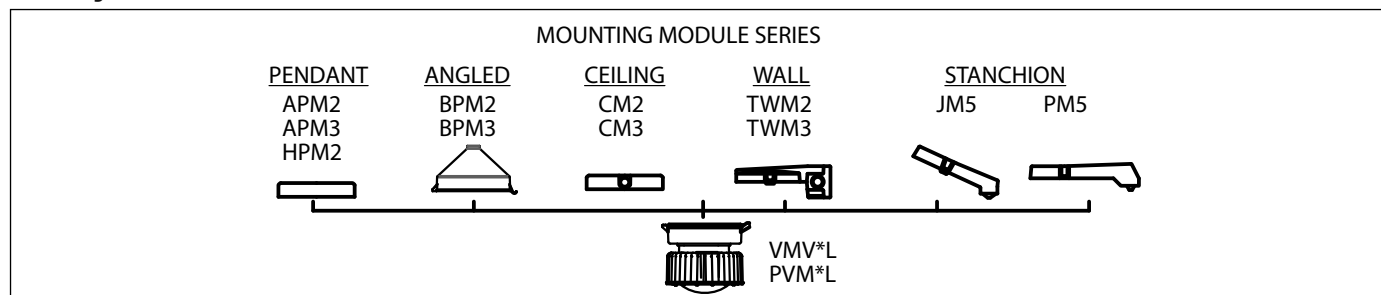

2L

Champ® VMV LED Series Luminaires

Improve safety, reliability and
energy efficiency

Cl. I, Div. 2, Groups A, B, C, D
Cl. I, Zone 2
Cl. II, Groups E, F, G
Cl. III

UL / cUL Listed
IECEx / ATEX
Simultaneous Presence
Wet Locations, Type 4X, IP66

Photometric Data:

Photometric Layout Comparison - Champ® VMV7L LED Versus 175W Metal Halide:

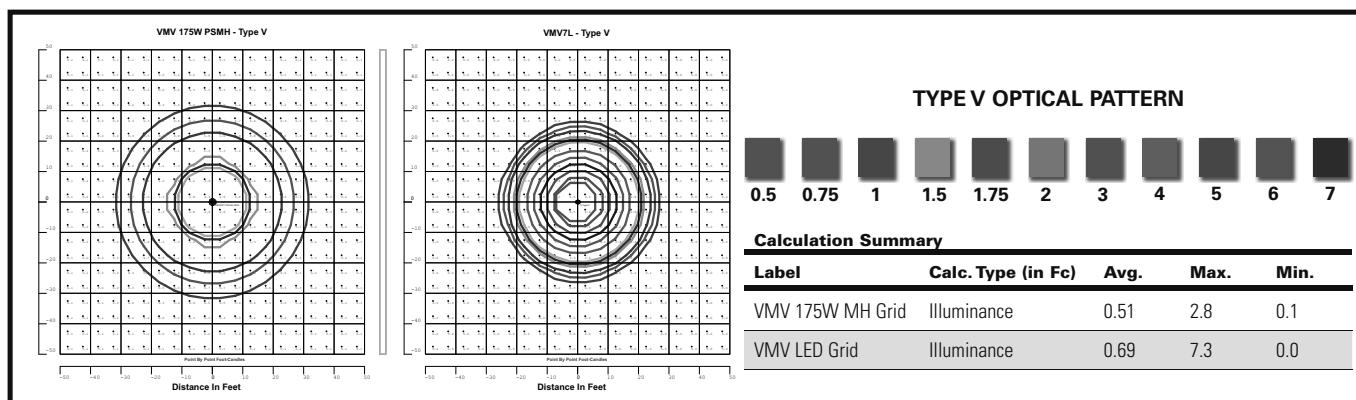
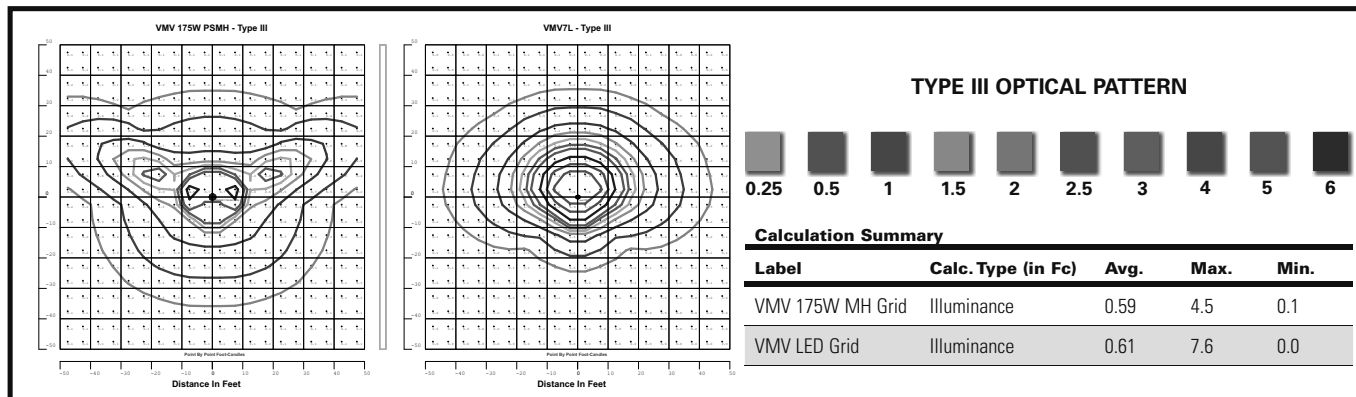
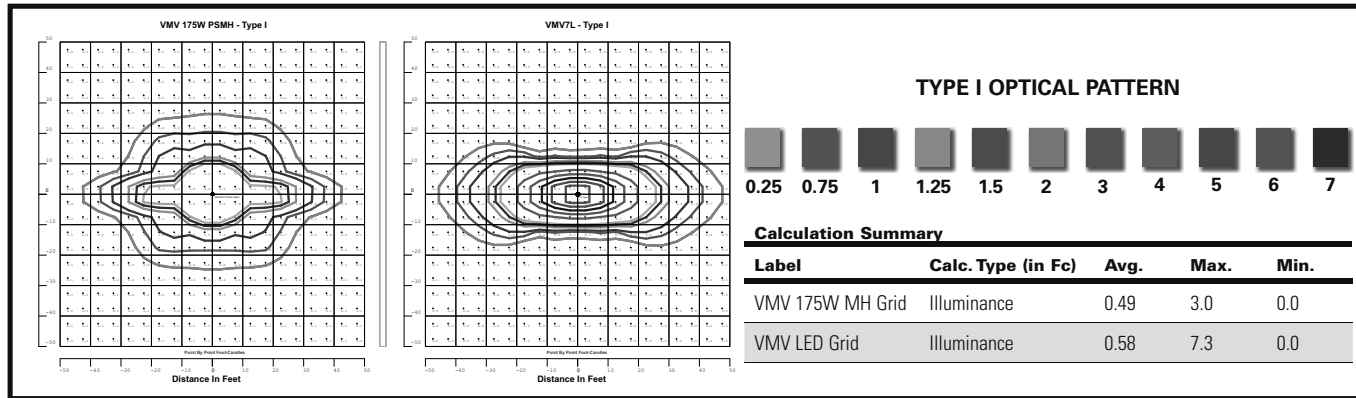

2L

Actual Lumens (Nominal†)	3L	5L	7L	9L	11L
Type I	3,115	4,687	6,562	8,437	9,692
Type III	3,271	4,921	6,890	8,859	10,177
Type V	3,515	5,288	7,404	9,519	10,935

†Tolerance +/- 10%.

Champ® FMV LED Series Floodlight Fixtures

Cl. I, Div. 2, Groups A, B, C, D
 Cl. I, Zone 2
 Cl. II, Groups E, F, G
 Cl. III

UL Listed & CSA Certified
 IECEx / ATEX
 Simultaneous Presence
 Wet Location, Type 4X, IP66

2L

The Champ FMV LED Family

FMV LED Series Floodlights are designed to provide full-spectrum, crisp, white light. Five versions of the Champ FMV LED are available, providing ideal solutions for a wide range of applications.

FMV Model	Equivalent MH HID Lamp	Energy Savings
FMV 5L	100W-150W	Up to 62%!
FMV 7L	150W-175W	
FMV 9L	175W-250W	
FMV 11L	250W-400W	
FMV 13L	400W	

Applications:

- Five lumen outputs allow for installation in numerous mounting heights
- Locations requiring continuous and consistent light levels in extreme ambient temperatures
- Areas requiring frequent on-and-off of lights
- Where flammable vapors, gases, ignitable dusts, fibers or flyings are present; indoors or outdoors
- Where extremely corrosive, wet, dusty, hot and/or cold conditions exist
- Type 4X, marine, wet locations, and hose-down environments
- Indoor and outdoor area lighting in plants, buildings, and parking areas
- Manufacturing plants; heavy industrial, chemical, petrochemical or pharmaceutical facilities; platforms; loading docks; outdoor mounted general area lighting

Drivers:

Model	5L - 13L
Standard	90-305 VAC, 50 / 60 Hz; 108-250 VDC
Option 1	347 VAC Model
Option 2	480 VAC Model

Champ FMV LED Benefits:

Enhance safety and productivity

- Instant illumination and restrike
- Better visibility with crisp, white light
- Minimum T4 temperature rating – safely operate in the most hazardous environments and any non-hazardous location
- Cold temperature operation / no warm-up required

Electrical Ratings:

	FMV 5L	FMV 7L	FMV 9L	FMV 11L	FMV 13L
Voltage Range, VAC	100-277V 50 / 60 Hz 347 / 480V 60 Hz				
Voltage Range, VDC	108-250	108-250	108-250	108-250	108-250
Input Power (Nom.)	64	89	121	149	179
Input Amps (Max.)	0.550	0.800	1.083	1.608	1.608
Power Factor	>0.85	>0.85	>0.85	>0.85	>0.85

Crouse-Hinds

by **E.T.N**

- “No lights out” feature – if a single LED fails, others will remain lit from other drivers – minimum 50% output maintained
 - Terminals – 3 x 6 sq. mm. for IEC version
- ### Reduce operation and maintenance costs
- Easy installation - compact modular fixture attaches onto existing SFA6 and SWB6
 - Energy-efficient technology – use up to 1/2 the power of standard HID luminaires
 - Provides up to 60,000 hours rated life – eliminates need for frequent lamp replacement
 - Contains no mercury or other hazardous substances

Reliable performance in any environment

- Shock- and vibration-resistant solid-state luminaires have no filaments or glass components that could break – greatly reduces the risk of premature failure
- Operating ambient -40°C to 55°C
- Dark sky friendly with optional visor

Certifications and Compliances:

- DesignLights Consortium® approved for select models (refer to Ordering Information for details)

NEC and CEC

- Class I, Division 2, Groups A, B, C, D
- Class I, Zone 2
- Class II, Groups E, F, G
- Class III
- Simultaneous Presence
- Wet Locations, Type 4X, IP66

UL Standards

- UL844
- UL1598 Luminaires, UL1598A Marine

CSA Standard

- CSA C22.2 No. 137

IECEx/ATEX

- IECEx UL 11.0054X
- Ex nA nR IIC T4 Gc Tamb -30°C to +55°C
- Ex nA nR IIC T5 Gc Tamb -30°C to +40°C
- Ex tc IIIC T68°C Dc IP66 Tamb -30°C to 40°C
- DEMKO 12 ATEX 115535X
- Ex II 3 G Ex nA nR IIC T4 Gc Tamb -30°C to +55°C
- Ex II 3 G Ex nA nR IIC T5 Gc Tamb -30°C to +40°C
- Ex II 3 D Ex tc IIIC T68°C Dc IP66 Tamb -30°C to +40°C
- CEPEL Ex-1956/10



Standard Materials:

- Housing – copper-free aluminum with Corro-free™ epoxy powder coat
- Lens – shatter-resistant glass
- Gaskets – silicone
- External hardware – stainless steel
- Factory-sealed, no external seals required

LED System:

- High brightness light emitting diode (LED) arrays
- Color temperature: 3000K (CRI 82) and 5600K (CRI 65) options available
- Advanced heat sink design ensures LED does not exceed manufacturer’s temperature ratings across all specified ambient conditions
- LM-80 reports available upon request

Options:

Description	Suffix
Fused (only applies to UNV1 model, not available for 347V or 480V; NOT marine or cUL Listed) (NEC version only)	S658
Two conduit/cable glands of like thread installed	S886

Accessories

(Order Separately):

Description	Cat. No.
Bolt-on visor (sold separately)	DSV1
Bolt-on wire guard (sold separately)	P61
Floodlight slipfitter (sold separately)	SFA6
Slipfitter wall mount adapter (sold separately)	SWB6

2L

Champ® FMV LED Series Floodlight Fixtures

Cl. I, Div. 2, Groups A, B, C, D
 Cl. I, Zone 2
 Cl. II, Groups E, F, G
 Cl. III

UL Listed & CSA Certified
 IECEx / ATEX
 Simultaneous Presence
 Wet Location, Type 4X, IP66

Safe, reliable heat transfer

The heat sink was designed to perform in high ambient temperatures up to +55°C and as low as -40°C. The thick walls of the castings make for a tough, rugged housing that keeps the internal driver and LED temperatures down, allowing them to perform flawlessly, and protects them from damage. Separated driver and LED housing allows dust to shed from fixture.



Installation and replacement made simple

The full-frame yoke was designed to utilize the SFA6 slipfitter and SWB6 wall mount bracket (sold separately), making it ideal for retrofit or new installations. The modular design of the FMV LED allows for easy driver or LED replacement, and allows for the addition of the optional visor or guard in the field. Single cable gland provided with a second plugged cable entry, if an additional cable gland is needed.



High efficiency and lumen output

High efficiency drivers and LED arrays provide reliable low cost operation in **harsh and hazardous environments**. Components were chosen to give industry-leading light output from an LED flood. Replaceable drivers and LEDs for ease of maintenance and "no lights out" feature.



Versatile design

Suitable for hazardous location use in **gas or dust areas**. Can be used for outdoor or indoor applications, and for a wide range of mounting heights depending on model and light level requirement. Optics were specifically designed to give the familiar and industry-accepted butterfly beam light pattern.

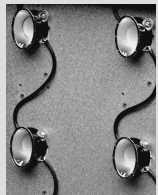

Optional equipment

Cool (C) and Warm (W) white color temperatures available. Optional visor offered (sold separately) to control light spill. Optional wire guard offered (sold separately) to protect lens from damage. Other options available - consult part numbering guide.

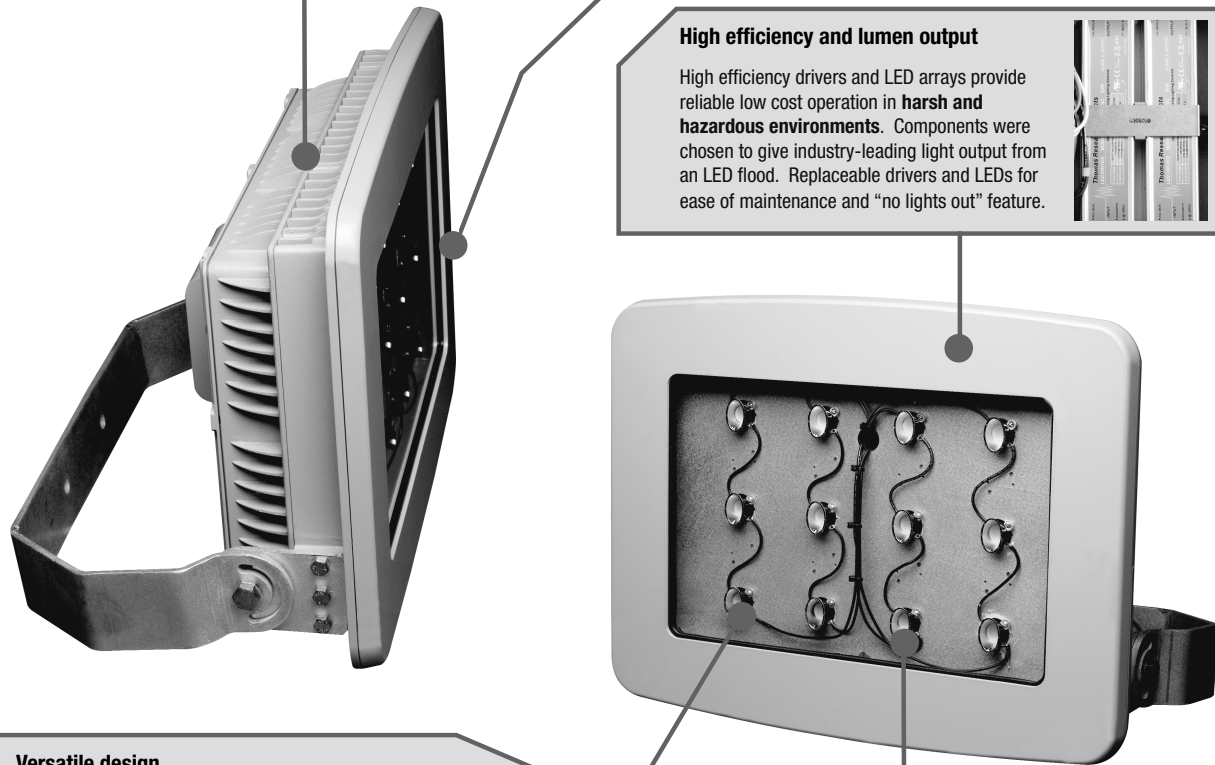

Champ® FMV LED Series Floodlight Fixtures

Cl. I, Div. 2, Groups A, B, C, D
 Cl. I, Zone 2
 Cl. II, Groups E, F, G
 Cl. III

UL Listed & CSA Certified
 IECEX / ATEX
 Simultaneous Presence
 Wet Location, Type 4X, IP66

2L

Catalog Numbering System:

SERIES	LIGHT SOURCE	COLOR	MOUNT	VOLTAGE	OPTICAL DISTRIBUTION	SUFFIXES
FMV	9L	C	Y	/UNV1	76	S658

SERIES

FMV NEC version with Class/Division ratings

NFMV IEC version with Class/Zone ratings

LIGHT SOURCE / INTENSITY

5L 100W - 150W equivalent

7L 150W - 175W equivalent

9L 175W - 250W equivalent

11L 250W - 400W equivalent

13L 400W equivalent

COLOR TEMPERATURE

C 5600K (cool white)

W 3000K (warm white)

MOUNT

Y Yoke

VOLTAGE

/UNV1 100 VAC to 277 VAC 50/60 Hz, 108 VDC to 250 VDC

/120 120 VAC 50/60 Hz**

/347 347 VAC 60 Hz

/480 480 VAC 60 Hz

OPTICAL DISTRIBUTION

76 Floodlight pattern optics included

SUFFIXES

M20 20mm metric threads for conduit opening (NFMV only)*

M25 25mm metric threads for conduit opening (NFMV only)*

S658 Fused; for UNV1 only; not for marine or cUL

S886 Two conduit/cable glands of like thread installed



ADDITIONAL ITEMS (SOLD SEPARATELY)

DSV1 DSV dark sky visor

P61 Wire guard factory installed

SFA6 Floodlight slipfitter

SWB6 Slipfitter wall mount adapter

*Required for NFMV. Please specify conduit entry.

**5 year limited warranty. Refer to page 2 of the D-0413 authorized distributor price book for Eaton's Crouse-Hinds standard Terms and Conditions. DesignLights Consortium® approved models. Cool white only.

Dimensions:

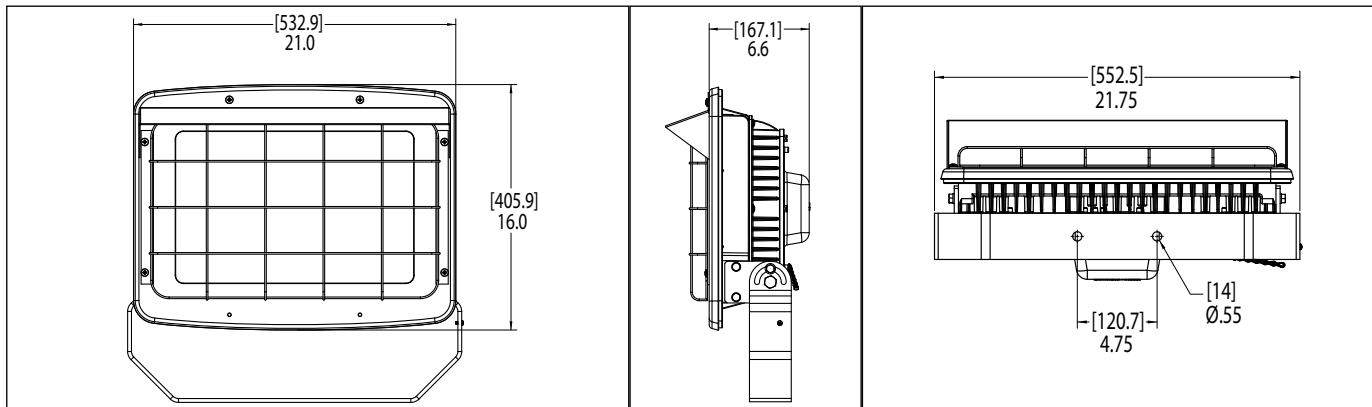

2L

2L

Champ® FMV LED Series Floodlight Fixtures

Cl. I, Div. 2, Groups A, B, C, D
 Cl. I, Zone 2
 Cl. II, Groups E, F, G
 Cl. III

UL Listed & CSA Certified
 IECEx / ATEX
 Simultaneous Presence
 Wet Location, Type 4X, IP66

Photometric Data:

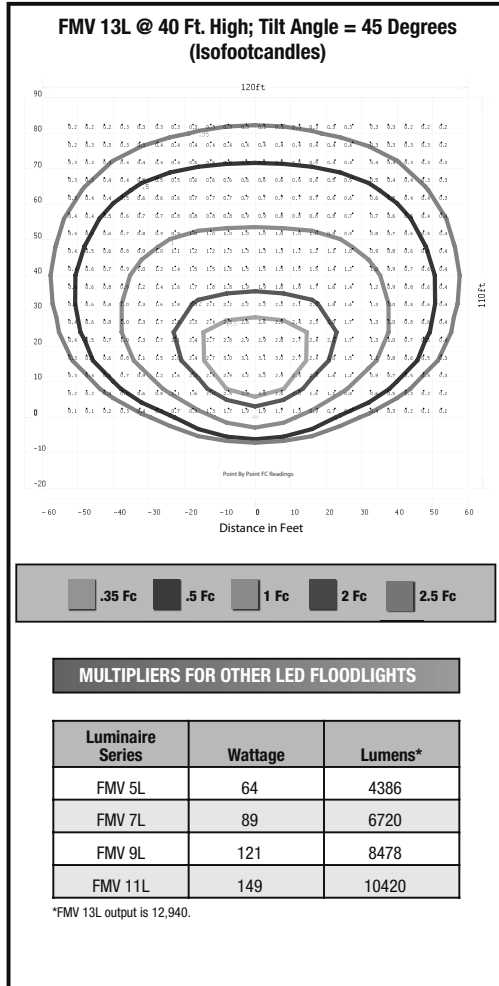

2L

Weights:

Model	Lbs.	Kg.
5L	39.11	17.74
7L	39.16	17.76
9L	39.73	18.02
11L	40.35	18.30
13L	40.35	18.30

Ambient Temperature:

	Max. Temp. °C	Cl. I, Div. 2	Cl. I, Zone 2	Simu. Presence Div. 1 and Div. 2	Cl. II, Div. 1	Cl. III
FMV 5L	40	T3C	T5	T3A	T5	T5
	55	T3C	T4	-	-	-
FMV 7L	40	T3C	T5	T3A	T5	T5
	55	T3C	T4	-	-	-
FMV 9L	40	T3C	T5	T3A	T5	T5
	55	T3C	T4	-	-	-
FMV 11L	40	T3C	T5	T3A	T5	T5
	55	T3C	T4	-	-	-
FMV 13L	40	T3C	T5	T3A	T5	T5
	55	T3C	T4	-	-	-

Vaporgard™ LED Series Luminaires

Leading the way in LED technology for industrial and hazardous applications

Cl. I, Div. 2, Groups A, B, C, D
Cl. II, Div. 1, Groups F, G
IECEX/ATEX

UL Listed & CSA Certified
Wet Location
NEMA 4X
IP66

2L

The Vaporgard LED Family:

V2LC/UNV - Cool White Color Temperature

The V2LC/UNV Luminaire provides uniform crisp, white light and is suitable for lower mounting heights, confined spaces, tunnels, or utility rooms. Using four high power, high brightness LED arrays, this fixture can deliver similar light levels to 150 watt incandescent.



V2LW/UNV - Warm White Color Temperature

The V2LW/UNV Luminaire provides similar benefits as the cool white version, but with a color rendering more consistent with a warm incandescent or HPS lamp source. Perfect for situations where Vaporgard LED will be installed next to a warmer color light source.

DC Power Supply - Available for Applications Requiring DC Power

For applications with DC power requirements such as solar or back-up battery. The DC power supply is suitable for 12VDC through 24VDC.

Applications:

Vaporgard LED Luminaires are ideal for use in:

- Wet, dirty, dusty, corrosive, hot/cold conditions
- Hazardous locations
- Confined space or low ceiling areas, such as tunnels, utility rooms, over doorways or entries, top of landings, etc.
- Areas requiring frequent on/off of lights
- Areas where maintenance is difficult or challenging
- Areas requiring shatter-protected products, such as food processing facilities
- Outdoor wall or ceiling mounted area illumination
- Low mounting heights

Vaporgard LED Benefits:

Enhance safety and productivity

- Instant illumination and restrike
- Cold temperature operation; no warm-up time
- Multi-die LED arrays improve reliability
- Lightweight, low profile, and cool surface temperatures
- Driver with internal fusing for branch circuit protection

Reduce operation and maintenance costs

- 22 watt LED system can save up to 85% in energy costs
- 50K hours rated life can provide >10 years of maintenance-free lighting
- No mercury or hazardous chemicals - eliminates disposal concerns
- Mounts to existing Vaporgard mounting modules

Reliable performance in any environment

- Shock- and vibration-resistant
- Teflon coated lens (suffix S896) option for increased safety in food processing facilities
- Low starting temperature: -30°C
- Operating ambient: -30°C to 55°C (High Temperature Option)
- Dark sky compliant

Certifications and Compliances:

- RoHS Compliant
- DesignLights Consortium® approved for select models (refer to Ordering Information for details)

NEC and CEC

- Class I, Division 2, Groups A, B, C, D
- Class II, Division 1, Groups F, G
- NEMA 4X

UL Standards

- IP66
- UL844

Crouse-Hinds

by **E.T.N**

- UL1598A Marine
- UL1598 Wet Locations

CSA Standard

- CSA C22.2 No. 137

IECEX/ATEX

- Ex II 3 G Ex nA IIC T4 Gc (T4 at 55°C)
- Ex II 3 D Ex tc IIIB T69°C Dc IP66
- EN60079-0:2009, EN60079-15:2010, EN60079-31:2009

Standard Materials:

- Body and mounting modules – copper-free aluminum with Corro-free™ epoxy powder coat
- Lens bezel – aluminum with anodized finish
- Lens – heat- and impact-resistant glass
- Gaskets – silicone
- External hardware – stainless steel
- Factory-sealed, no external seals required

LED System:

- (4) High brightness LED arrays
- Cool white (5600K), CRI 65
- Warm white (3000K), CRI 82
- 70% lumen maintenance (L₇₀) at 50K hours
- Junction temperature T_j <90°C ensures long life
- Array complies with requirements of IEC LM80

LED Drivers:

- Constant current regulated power supply
- 90VAC - 264VAC, 277VAC, 50/60Hz
- Internal fusing
- Active power factor correction, >0.9
- Low harmonic distortion, <20%
- Low inrush current, <20 amps
- EMC compliant to 47CFR, Part 2, Part 15
- 12VDC/24VDC option available

Options:

Description	Suffix
Frosted lens reduces glare in applications where the user may have direct visual contact with the light source (NEC version only)	S891
Teflon coating on lens provides additional shatter protection for applications in food and beverage facilities (NEC version only)	S896
High temperature option allows operation up to 55°C ambient temperature (AC unit only)	S902
Brazil (CEPEL) certification (IEC version only)	BR

Electrical Ratings:

	Series			
	V2LC/UNV1*	V2LW/UNV1	V2LC/DC1	V2LW/DC1
Voltage	90-264VAC, 277VAC	90-264VAC, 277VAC	12-24VDC	12-24VDC
Input Power (Watts)	22	22	22	22
Input Current	0.23 / 0.10	0.23 / 0.10	2.1 / 1.0	2.1 / 1.0
Power Factor	>0.9	>0.9	N/A	N/A
THD (I) (%)	<20%	<20%	N/A	N/A
Maintained Lumens	1633	1400	1633	1400
Efficacy, LPW	64	56	64	56
Color Temperature	5600K	3000K	5600K	3000K

*5 year limited warranty. Refer to page 2 of the D-0413 authorized distributor price book for Eaton's Crouse-Hinds standard Terms and Conditions. DesignLights Consortium approved models.



2L

Vaporgard™ LED Series Luminaires

Leading the way in LED technology for industrial and hazardous applications

Cl. I, Div. 2,
Groups A, B, C, D
Cl. II, Div. 1,
Groups F, G
IECEX/ATEX

UL Listed & CSA Certified
Wet Location
NEMA 4X
IP66

Installation and replacement made simple

This contractor-friendly design is ideal for both retrofit and new construction applications. These luminaires are installed using the same wall and ceiling mounting modules as existing Vaporgard fixtures.



Safe, reliable heat transfer

Heat sink - engineered to safely and effectively remove heat from the LED and the driver, while providing durable protection for the optical elements of the fixture. This unique design increases overall flexibility of the luminaire by reducing both driver temperature and junction temperature of the LED arrays.



Easy Maintenance and Component Replacement

The compact and modular design of the Vaporgard LED allows for both easy component replacement and future upgrade.

Unique domeless, low profile design

Unique domeless, low profile design for low mounting heights and confined spaces where incandescent and HID based luminaires are too large to fit the mechanical envelope required.



LED Arrays

Four high power multi-die LED arrays provide instant on and full illumination throughout specified operational temperature range. Since LEDs contain no filament or lamp, the fixture can survive even the harshest environmental conditions and exposure to high, repeated vibration.



2L

Vaporgard™ LED Series Luminaires

Leading the way in LED technology for industrial and hazardous applications

Cl. I, Div. 2, Groups A, B, C, D
Cl. II, Div. 1, Groups F, G
IECEX/ATEX

UL Listed & CSA Certified
Wet Location
NEMA 4X
IP66

2L

Ordering Information - NEC and CEC:

Mounting Style	Cool White		Warm White	
	AC Drive	DC Drive	AC Drive	DC Drive
1/2" Pendant*	V2LCA1/UNV1***	V2LCA1/DC1	V2LWA1/UNV1	V2LWA1/DC1
3/4" Pendant*	V2LCA2/UNV1***	V2LCA2/DC1	V2LWA2/UNV1	V2LWA2/DC1
1" Pendant*	V2LCA3/UNV1***	V2LCA3/DC1	V2LWA3/UNV1	V2LWA3/DC1
1/2" Wall with Junction Box	V2LCHBF1/UNV1***	V2LCHBF1/DC1	V2LWHBF1/UNV1	V2LWHBF1/DC1
3/4" Wall with Junction Box	V2LCHBF2/UNV1***	V2LCHBF2/DC1	V2LWHBF2/UNV1	V2LWHBF2/DC1
1/2" Ceiling	V2LCHF1/UNV1***	V2LCHF1/DC1	V2LWHF1/UNV1	V2LWHF1/DC1
3/4" Ceiling	V2LCHF2/UNV1***	V2LCHF2/DC1	V2LWHF2/UNV1	V2LWHF2/DC1
1/2" VXT Wall	V2LCHT1/UNV1***	V2LCHT1/DC1	V2LWHT1/UNV1	V2LWHT1/DC1
3/4" VXT Wall	V2LCHT2/UNV1***	V2LCHT2/DC1	V2LWHT2/UNV1	V2LWHT2/DC1
1/2" VXW Wall*	V2LCHW1/UNV1***	V2LCHW1/DC1	V2LWHW1/UNV1	V2LWHW1/DC1
3/4" VXW Wall*	V2LCHW2/UNV1***	V2LCHW2/DC1	V2LWHW2/UNV1	V2LWHW2/DC1
1 1/4" Stanchion*	V2LCHJ4/UNV1***	V2LCHJ4/DC1	V2LWHJ4/UNV1	V2LWHJ4/DC1
Adapter Only**	V2LCHR/UNV1***	V2LCHR/DC1	V2LWHR/UNV1	V2LWHR/DC1

*For use in Class I, Division 2 or Class II, Division 1, Groups F, G. For Class II, you must order complete catalog number (not available for purchase in components).

**For use when wall mount or ceiling mount box is already installed.

***5 year limited warranty. Refer to page 2 of the D-0413 authorized distributor price book for Eaton's Crouse-Hinds standard Terms and Conditions. DesignLights Consortium® approved models. Cool white only.

Ordering Information - IECEX/ATEX:

Mounting Style	Cool White	Warm White
	AC Drive	AC Drive
1/2" Pendant	NV2LCA1/UNV1	NV2LWA1/UNV1
3/4" Pendant	NV2LCA2/UNV1	NV2LWA2/UNV1
1" Pendant	NV2LCA3/UNV1	NV2LWA3/UNV1
1/2" Wall with Junction Box	NV2LCHBF1/UNV1	NV2LWHBF1/UNV1
3/4" Wall with Junction Box	NV2LCHBF2/UNV1	NV2LWHBF2/UNV1
1/2" Ceiling	NV2LCHF1/UNV1	NV2LWHF1/UNV1
3/4" Ceiling	NV2LCHF2/UNV1	NV2LWHF2/UNV1
1/2" Wall	NV2LCHT1/UNV1	NV2LWHT1/UNV1
3/4" Wall	NV2LCHT2/UNV1	NV2LWHT2/UNV1
1 1/4" Stanchion	NV2LCHJ4/UNV1	NV2LWHJ4/UNV1

Note: For IEC applications, you must order complete catalog number (not available for purchase in components).

Weights:

Luminaire & Mounting Module Weight	Lbs.
Pendant Mount	5.7
Ceiling Mount	6.8
Wall Mount	7.9
Stanchion Mount	6.5

Temperature Ratings:

	Max. Temp. °C	Temp. Rating†
V2LC/UNV1	40	T5
V2LC/UNV1 S902	55	T4A
V2LC/DC1	40	T5
NV2LC/UNV1	40	T4
NV2LC/UNV1 S902	55	T4

†Contact your local sales representative for warm white temperature ratings.

Dimensions:

Pendant

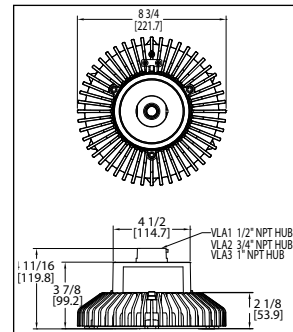

Wall

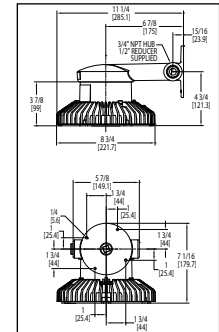

Ceiling

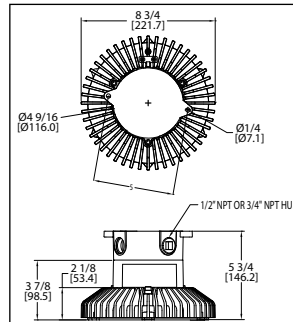

Stanchion

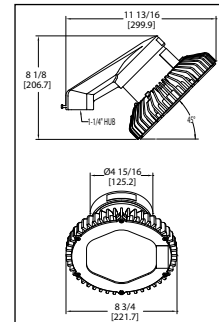

Family Tree:

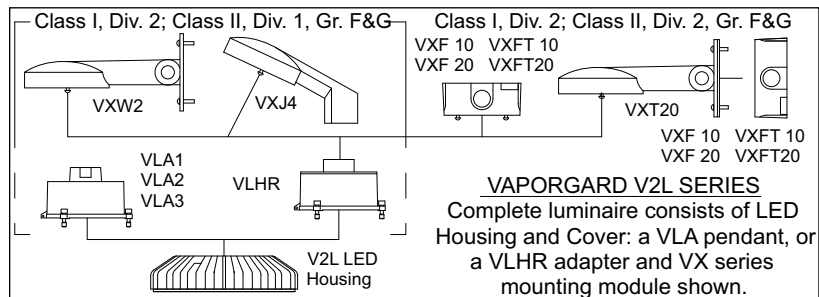

2L

Vaporgard™ LED Series Luminaires

Leading the way in LED technology for industrial and hazardous applications

Cl. I, Div. 2,
Groups A, B, C, D
Cl. II, Div. 1,
Groups F, G
IECEX/ATEX

UL Listed & CSA Certified
Wet Location
NEMA 4X
IP66

Photometric Data:

Vaporgard™ LED (22 Watt)

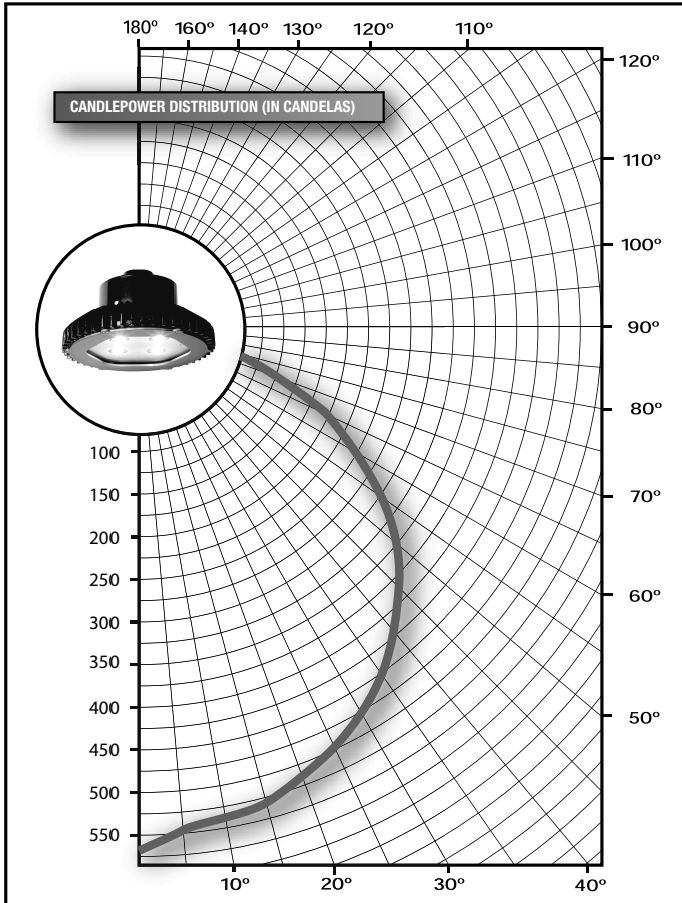

ZONAL LUMENS

ZONE	LUMENS	% LUMEN
0-30	468	28.65
0-40	772	47.30
0-60	1374	84.15
0-90	1633	100.00
40-90	860	52.70
60-90	259	15.85
90-180	0	0.00
0-180	1633	100.00

DISTANCE TO MOUNTING HEIGHT
Isofootcandle chart shows illuminance in foot-candles at ground level

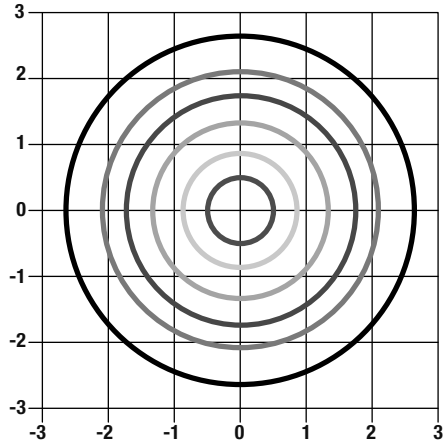

ISOFOOTCANDLE CHART
Footcandle Values for Isofootcandle Lines

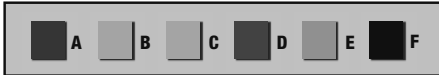

Mtg. Hgt.	A	B	C	D	E	F
6'	10.00	5.00	2.00	1.00	0.50	0.20
8'	5.62	2.81	1.13	0.56	0.28	0.11
10'	3.60	1.80	0.72	0.36	0.18	0.07
12'	2.50	1.25	0.50	0.25	0.13	0.05
14'	1.84	0.92	0.37	0.18	0.09	0.04

2L

N2LPS LIGHT-PAK™ Emergency Lighting System

Cl. I, Div. 2, Groups B, C, D
Cl. I, Zone 2
Cl. II, Div. 2, Groups F, G
Wet Locations, Marine
NEMA 3, 3R, 4X
Ambient 0°C to 55°C

2L

Applications:

LED N2LPS Light-Pak™ emergency lighting systems are used:

- To provide reliable illumination for egress areas during failure or interruption of power to the normal lighting system
- In areas where flammable gases or vapors may become present due to abnormal, unusual, or accidental conditions
- In manufacturing plants, refineries, petrochemical and chemical plants, waste and sewage treatment facilities, oil terminals, food processing facilities, breweries, and other industrial manufacturing or process industry facilities subject to wet or corrosive conditions
- To illuminate machinery or panels during a loss of AC power
- Where moisture, dirt, dust, or corrosion will limit the life and reliability of ordinary emergency lighting systems
- Where required by the National Electrical Code®, the Life Safety Code® or other applicable codes
- Outdoor applications

Features:

- Compact, factory-assembled luminaire featuring LED lamps for improved lumen performance, on-time, and lamp life
- Nonmetallic, enclosed, and gasketed housing provides corrosion protection in the most extreme environments
- Durable and marine rated LED lamp head assemblies provide protection against water ingress, corrosion, and impact
- High temperature rated nickel cadmium battery for reliable operation up to 55°C ambient
- Solid state battery charger for long life and reliable battery operation prevents deep discharge by automatically disconnecting the battery from the luminaire
- Factory-installed "push-to-test" button
- Self-test, monitoring, and diagnostics reduce costly maintenance checks
- Remote luminaire head assemblies (one or two) are available for mounting of luminaire heads away from main power system
- Stainless steel drain minimizes moisture collection
- Standard battery disconnect switch (Krydon® unit)

Certifications and Complies:

NEC/CEC:

- Class I, Division 2, Groups B, C, D, Zone 2

UL Standards:

- 1598A (Supplemental Requirements for Luminaires for Installation on Marine Vessels)
- 924 (Emergency Lighting and Power Equipment)
- 844 (Electric Luminaires Hazardous Locations)

CSA Standards:

- C22.2 No. 141-M1985 unit equipment for emergency lighting
- C22.2 No. 137-M1981 non-incendive electrical equipment for use in Class I, Division 2 hazardous locations
- Life Safety Code NFPA101® – Section 5-9 (Emergency Lighting)
- Marine wet locations suitability, Type 4X

Standard Materials:

- Power supply and remote luminaire enclosures – Krydon® fiberglass-reinforced polyester
- LED lamp head assembly – epoxy powder coated stainless steel
- Exterior hardware – nylon, plastic coated, and stainless steel
- Cover gasket – Hypalon® synthetic rubber

Temperature Performance Data:

Based on 55°C ambient

Cat. #	Class I, Division 2	Class II, Division 1
N2LPS (all)	40°C - T5; 55°C - T4A	T6
N2RF (all)	T5	T6

Note: Ambient temperature at which the Light-Pak system is rated is 0°C to 55°C. Operation at temperatures outside this range will affect the battery life and/or charging performance.

Note: Battery time in emergency mode is 90 minutes. **National Electrical Code and Life Safety Code** are registered trademarks of the National Fire Protection Association, Inc.

Noryl is a registered trademark of General Electric Company.



Electrical Ratings:

- Power supply –
Input: 120, 220, 230, 240, or 277 VAC, 50 or 60 Hz; 9 watts max.
Output: 18 watts max. at 12 VDC
- Luminaire heads –
Voltage: 12 VDC; Lamp: 3 watt LED
Total lumen output: 80

Unit Net Weights:

- N2LPS12222 – 16 lbs.
- N2LPS12220 – 12 lbs.
- N2RF1221 – 8 lbs.
- N2RF1222 – 9 lbs.

Options:

Description	Suffix
55°C suitability	S904

2L

2L

N2LPS LIGHT-PAK™ Emergency Lighting System

Cl. I, Div. 2, Groups B, C, D
Cl. I, Zone 2
Cl. II, Div. 2, Groups F, G
Wet Locations, Marine
NEMA 3, 3R, 4X
Ambient 0°C to 55°C

Ordering Information:

Description	Cat. #
28 watt, 12 volt power supply assembly with two 3 watt LED lamp heads	N2LPS12222
28 watt, 12 volt stainless steel power supply assembly with two 3 watt LED lamp heads	N2LPS12222 SS
28 watt, 12 volt power supply assembly less luminaire heads	N2LPS12220*
Remote luminaire assembly with one 3 watt LED lamp head	N2RF1221*
Remote luminaire assembly with two 3 watt LED lamp heads	N2RF1222*
28 watt, 120V LED Light-Pak with single sided exit sign**	N2LPS12222/120 EXS DR0391734
28 watt, 277V LED Light-Pak with single sided exit sign**	N2LPS12222/277 EXS DR0391734
28 watt, 120V LED Light-Pak with double sided exit sign**	N2LPS12222/120 EXD DR0391734
28 watt, 277V LED Light-Pak with double sided exit sign**	N2LPS12222/277 EXD DR0391734

*Not cUL approved. UL Listed only.

**Exit sign operates in both normal and emergency mode.

Note: Up to four (4) remote LED lamp assemblies can be connected to the N2LPS12222. Up to six (6) remote LED lamp assemblies can be connected to the N2LPS12220.

Wire Sizing for Remote Installation:

For Copper Wire –

Running Distance† (ft.) Between Power Supply and Remote Luminaire

Wire Size	Load In Watts				Wire Size	Load In Watts			
	8	16	24	32		8	16	24	32
16 AWG	26	13	6	3	10 AWG	106	53	26	13
14 AWG	42	21	10	5	8 AWG	168	84	42	21
12 AWG	66	33	16	8	6 AWG	270	135	67	33

†Maximum distance to limit line voltage drop to 5%.

Dimensions (N2LPS):

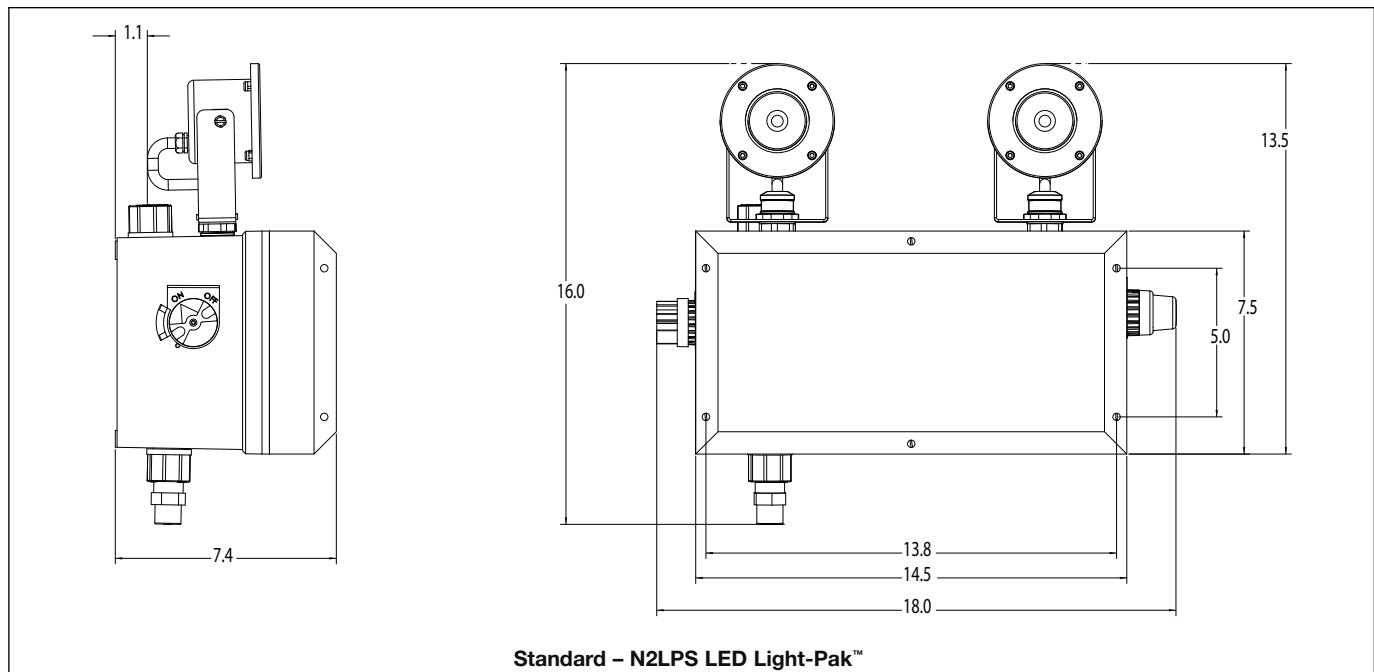

2L

N2LPS LIGHT-PAK™ Emergency Lighting System

Cl. I, Div. 2, Groups B, C, D
Cl. I, Zone 2
Cl. II, Div. 2, Groups F, G
Wet Locations, Marine
NEMA 3, 3R, 4X
Ambient 0°C to 55°C

2L

Dimensions (N2LPS):

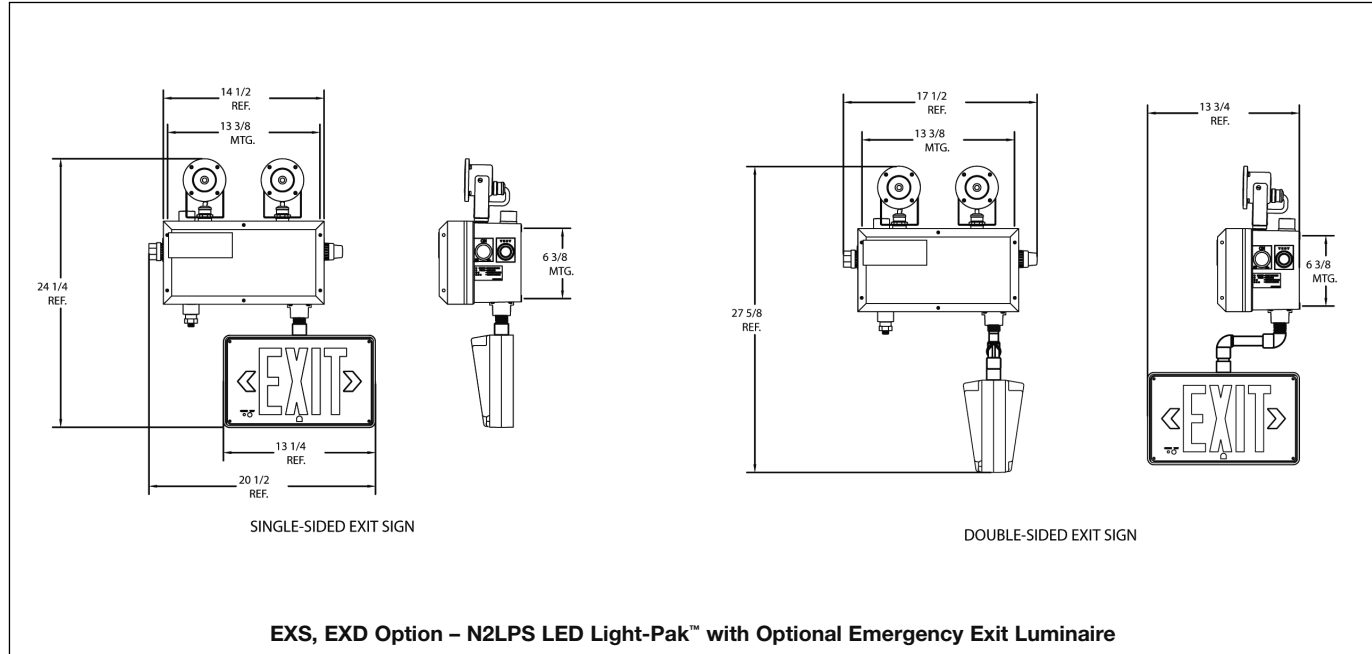

Dimensions (N2RF):

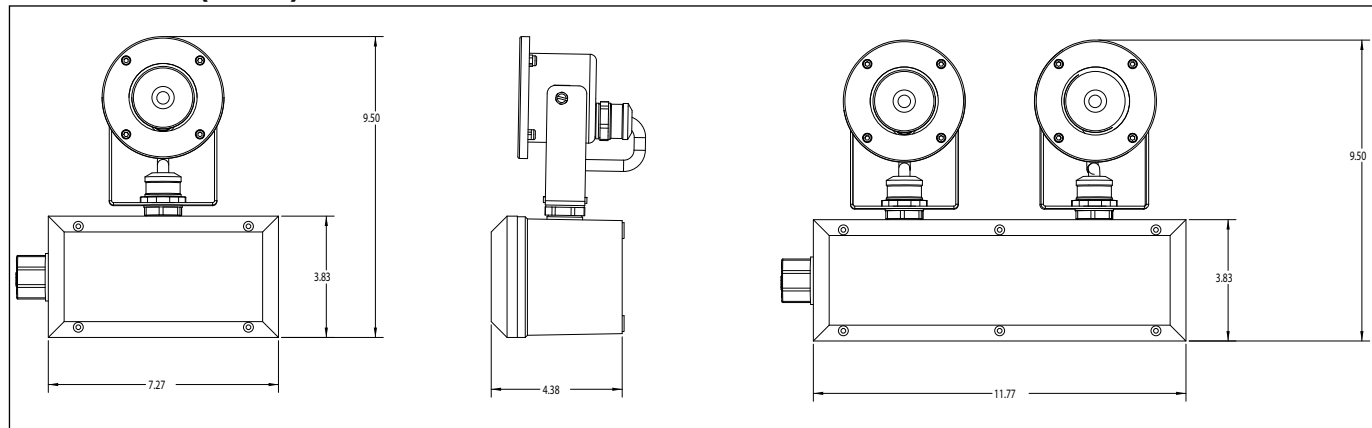

2L

Detail Indication Logic:

Status Indication	Status Description	Status Definition
	No Light	AC Power Removed from Circuit
*	Steady Light (No Blinks)	Fully Charged
_	Light Blinks Once	Battery Charging
_	Light Blinks Twice	Battery Failure
_	Light Blinks Three Times	Circuit Failure

2L Ex-Lite LED Exit Signs

Cl. I, Div. 2, Groups A, B, C, D
 Cl. I, Zone 1, AEx em ib IIC (NEC)
 Cl. I, Zone 1, Ex em ib IIC (CEC)
 Cl. II, Div. 2, Groups F, G (NEC)
 Cl. II, Div. 2, Groups E, F, G (CEC)

UL Listed
 IP66

The Ex-Lite Series of LED exit signs are designed for hazardous locations and are ideally suited for marking escape routes and exits in potentially explosive atmospheres.

The Ex-Lite Z is available as an AC only version, while the Ex-Lite ZE is available with self-contained battery. As an emergency lighting luminaire with self-contained battery system, the Ex-Lite ZE features a nickel cadmium battery with automatic test and monitoring feature.

Applications:

- In harsh and hazardous environments where illuminated exit signs are required

Features and Benefits:

LED Technology:

- Long life (>50K hours) for years of maintenance-free operation
- Energy-efficient for lower cost of operation
- Low temperature operation with no loss of illumination
- Rugged and durable light source for the harshest of environments

Exit Sign System:

- Can be used in a hazardous location
- Conduit or cable entry
- Can be installed in moist, humid, rain, and wet environments
- Universal input voltage 110VAC-277VAC and 110VDC-250VDC reduces inventory
- Ex-Lite ZE with self-monitoring, self-diagnostic, and test capability
- Premium heavy-duty nickel cadmium battery
- 24-hour charge and recharge time increases safety by recovering quickly from outage
- "EXIT" legend with alternative wings - left, right, or left and right; simple field modification
- Emergency lighting cycle three hours
- The housing of the luminaire is constructed with a corrosion resistant, robust, lightweight aluminum alloy material and illumination of the sign is provided with red, high-efficient LEDs

Certifications and Compliances:

- Class I, Division 2, Groups A, B, C, D
- Class I, Zone 1, AEx em ib IIC (NEC)
- Class I, Zone 1, Ex em ib IIC (CEC)
- Class II, Division 2, Groups F, G (NEC)
- Class II, Division 2, Groups E, F, G (CEC)
- IP66
- UL844
- UL924/CSA22.2 No. 141-02
- UL60079/CSA22.2 E60079
- UL1203/CSA22.2 E6124-1-1-02



Ordering Information:

Catalog Number	Ex Lite Z	Ex Lite ZE
Material Number	12191001005	12191130005
Description	AC/DC Exit Sign	with Battery
Light Source	LED	LED
Life of LED	50K hours	50K hours
Rated Voltage, VAC	120V-277V	120V-277V
Frequency, Hz	50/60	50/60
Rated Voltage, DC	110V-250V	110V-250V
Power Consumption	6VA	6VA
Battery	N/A	NiCad
Allowable Temperature Range	-4°F to 122°F (-20°C to 50°C)	41°F to 95°F (5°C to 35°C)*
Mounting	Wall	Wall
Cable Entry	Ex-e	Ex-e
Conduit Entry	3/4"	3/4"
Protection	IP66	IP66

*Due to battery chemistry, the charging capacity will be limited at temperatures below 5°C and above 35°C.

Dimensions In Inches (mm):

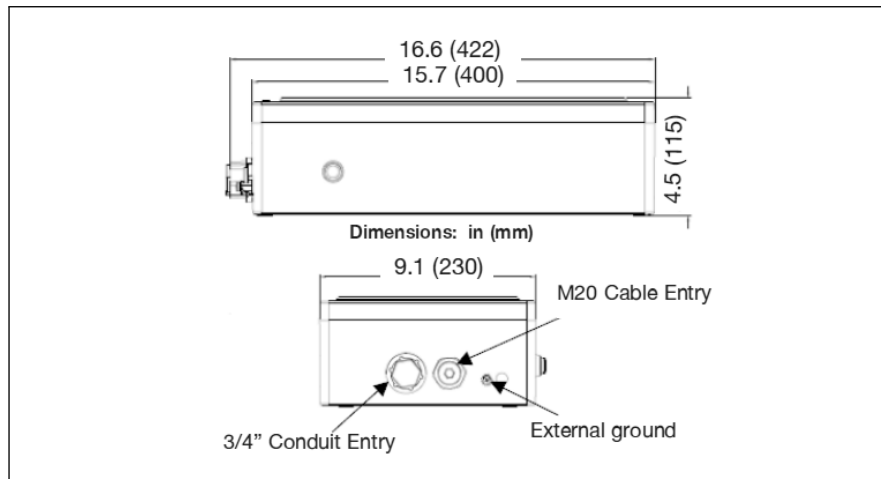

Crouse-Hinds
 by **E.T.N**

CCH UX Series LED Exit Signs

UL Listed
Available with Cl. I, Div. 2,
Groups A, B, C, D rating

NEMA 4X, IP66

2L

Eaton's Crouse-Hinds CCH UX Series LED Exit Sign combines the strength and durability of die cast aluminum with architecturally-pleasing aesthetics. The CCH UX Series is illuminated by LEDs, providing the customer with a long-life, low maintenance, dependable exit sign for use in conditions where reliability is crucial.

Designed for the most severe environments, the CCH UX Series will provide maximum performance against rain, moisture, cold, corrosion, and dust in applications such as manufacturing plants, refineries, petrochemical and chemical plants, waste and sewage treatment facilities, food processing, and other industrial facilities.

Applications:

- In locations deemed hazardous due to the presence of flammable vapors or gases
- In areas where the presence of gases or vapors may become present during an abnormal, unusual, or accidental conditions
- Outdoor and wet applications
- Where required by the National Electrical Code®, Life Safety Code®, or other applicable codes

Features and Benefits:

- Wet location, outdoor rated for use in the most demanding environments
- Optional hazardous location rating available
- Dual voltage 120V/277V reduces wiring errors
- Heavy-duty nickel cadmium battery for long life
- 24-hour charge and recharge recovery time increases safety
- Heavy-duty injection molded polycarbonate lens protects against impact and corrosion
- Brown-out protection protects battery and reduces labor
- Heavy-duty aluminum die cast housing protects against impact and chemical resistance
- LEDs provide long life, even illumination, and energy savings
- Wide operating temperature range (-45°C to 45°C)
- Self-diagnostic testing reduces costs by eliminating scheduled equipment verification tests
- Heavy duty nickel cadmium battery for long life meets 90 minute requirements for battery operated emergency system

Certifications and Compliances:

- NEMA 4X, UL50
- UL924 wet location
- IP65, IP66
- Available with NEC hazardous location rating - UL844 Class I, Division 2, Groups A, B, C, D

Dimensions

In Inches:

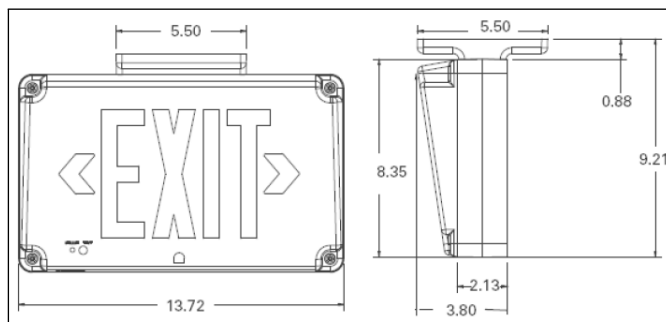

Mounting: wall mount, ceiling mount, end mount
Conduit Entry: top, bottom, or either side of the unit



Benefits of LED Technology:

- Provides safe and reliable exit marking both indoors and outdoors during power failure or interruption of power to normal lighting system
- Long life (>50K hours) for years of maintenance-free operation
- Energy-efficient for lower cost of operation
- Low temperature operation with no loss of illumination
- Rugged and durable light source for the harshest of environments

Temperature Performance Data:

CCH UX Series Exit Sign:

- -45°C (-49°F) to 45°C (113°F)

CCH UX-HAZ Hazardous Location Exit Sign:

- T6 rating at 45°C (113°F)

Electrical Ratings:

- | | |
|--|---------------------|
| • Power Supply
120V/277V dual voltage | • LED Exits - Green |
| • LED Exits - Red | Input Power |
| Input Power | 120V = 2.7W |
| 120V = 2.7W | 277V = 3.0W |
| 277V = 3.2W | |
| Input Current: | Input Current: |
| (Max.) | (Max.) |
| 120V = .07A | 120V = .08A |
| 277V = .04A | 277V = .03A |

Ordering Information:

Catalog Number	Housing Finish	Letter Color
CCH UX70RSDHAZ	Silver Housing	Red LED
CCH UX60RHAZ	Silver Housing	Red LED
CCH UX70GSDHAZ	Silver Housing	Green LED
CCH UX60GHAZ	Silver Housing	Green LED
CCH UX70RSD	Silver Housing	Red LED
CCH UX70RWHSD	White Housing	Red LED
CCH UX70RBKSD	Black Housing	Red LED
CCH UX60R	Silver Housing	Red LED
CCH UX60RWH	White Housing	Red LED
CCH UX60RBK	Black Housing	Red LED
CCH UX70GSD	Silver Housing	Green LED
CCH UX70GWHSD	White Housing	Green LED
CCH UX70GBKSD	Black Housing	Green LED
CCH UX60G	Silver Housing	Green LED
CCH UX60GWH	White Housing	Green LED
CCH UX60GBK	Black Housing	Green LED

Crouse-Hinds
by **EATON**

2L

2L Pro Series Industrial LED Luminaires

The robust Pro Series LED family allows for replacement of existing HID, floodlights, and incandescent industrial fixtures, and provides an energy-efficient, proven light source for use in applications where reliability is crucial.

Applications:

- Robust Pro Series LED family allows for replacement of existing HID, floodlights, and incandescent industrial fixtures
- Locations requiring continuous and consistent light levels in extreme ambient temperatures
- Areas requiring frequent on-and-off of lights
- Areas that are difficult to relamp or that cause production to be stopped during the lamp maintenance process
- Where extremely corrosive, wet, dusty, hot and/or cold conditions exist
- Type 4X, marine, wet locations and hose-down environments
- Warehouses, outdoor areas, production facilities, etc.





PRO SERIES LED BENEFITS

- A Customized heat sinks**
Eaton's Crouse-Hinds' heat sinks are specifically engineered to remove heat from the LEDs and driver to ensure longer life, better lumen output, and accurate color temperature.
- B Retrofittable mounting modules**
Compact modular fixtures attach to existing Eaton's Crouse-Hinds installed mounting modules, reducing installation costs.
- C Long life LEDs eliminate maintenance cost**
Eaton's Crouse-Hinds' luminaires remove the high maintenance costs associated with traditional lamps.

Product Selector Chart:

2L

			
Series	Champ® Pro PVM Series	Champ® Pro PFM Series	Vaporgard™ Pro P2L Series
Certifications	UL1598; UL1598A; cUL; Type 4X; IP66; CE	UL1598; UL1598A; cUL; NEMA 4X; IP66	UL1598; UL1598A; cUL; NEMA 4X; IP66
Applications / Uses	<ul style="list-style-type: none"> • General high bay/low bay illumination 	<ul style="list-style-type: none"> • Outdoor/indoor flood illumination 	<ul style="list-style-type: none"> • Low mounting heights, such as stairways, walkways, and doorways • Targeted illumination
Equivalent Output	Replaces 70W to 400W HID	Replaces 70W to 400W HID	Replaces up to 200W incandescent
Mounting Styles	Wall; Ceiling; Pendant; Flexible Pendant; Cone Pendant; Stanchion	Yoke Mounted	Wall; Ceiling; Pendant; Stanchion
Photometrics and Test Reports Available	<ul style="list-style-type: none"> • IES Photometric Files • LM-80 Lumen Maintenance Report • LM-79 Test Report 	<ul style="list-style-type: none"> • IES Photometric Files • LM-80 Lumen Maintenance Report • LM-79 Test Report 	<ul style="list-style-type: none"> • IES Photometric Files • LM-80 Lumen Maintenance Report • LM-79 Test Report

Champ® Pro PVM Series Luminaires

UL/cUL Listed
Type 4X
IP66

2L

Ideal for general high bay/low bay illumination

The Champ® Pro PVM Family

Champ® Pro PVM Series Luminaires are designed to provide full-spectrum, crisp, white light with custom IES Type I, III, and V distribution. Five versions of the PVM Series are available, providing ideal solutions for a wide range of applications.

Model	Nominal† Lumens (Type V)	Wattage	Equivalent HID Luminaire	Typical Energy Savings / Lifetime
PVM3L	3,515	41	70W-100W	Up to 77%
PVM5L	5,288	67	100W-150W	Up to 67%
PVM7L	7,404	94	150W-175W	Up to 67%
PVM9L	9,515	114	250W-400W	Up to 74%
PVM11L	10,935	118	400W	Up to 74%

†Tolerance +/- 10%.



Applications:

- Locations requiring continuous and consistent light levels in extreme ambient temperatures
- Areas requiring frequent on-and-off of lights
- Where extremely corrosive, wet, dusty, hot and/or cold conditions exist
- Manufacturing plants; heavy industrial, chemical, petrochemical, or pharmaceutical facilities; food and beverage facilities; mining; platforms; loading docks; tunnels; indoor/outdoor spot lighting; outdoor wall and stanchion mounted general area lighting

Champ Pro PVM LED Benefits:

- Instant illumination and restrike
- Better visibility with crisp, white light
- Cold temperature operation / no warm-up required
- Redundancy in drivers with multiple series circuits connected to each driver to avoid complete loss of illumination
- Easy installation - compact modular fixture attaches onto existing Champ® mounting module
- Energy-efficient technology - up to 77% energy savings over HID fixtures
- Provides up to 60,000 hours rated life and up to 170,000 hours of economic life - eliminates need for frequent lamp replacement
- Contains no mercury or other hazardous substances
- Shock- and vibration-resistant solid-state luminaires have no filaments or glass components that could break - greatly reduces the risk of premature failure
- Operating ambient -40°C to 55°C
- Dark sky compliant
- 5 year fixture warranty††

††Refer to page 2 of the D-0413 authorized distributor price book for Eaton's Crouse-Hinds standard Terms and Conditions.

Certifications and Compliances:

- DesignLights Consortium® for select models* (pending)

NEC and CEC

- Wet Locations, Type 4X, IP66

UL Standards

- UL1598 Luminaires, UL1598A Marine

CSA Standard

- cUL Listed to CSA Standard CSA C22.2 No. 250

IEC Standard

- CE

*Cool white 120-277 VAC 3L-11L models. Refer to page 2 of the D-0413 authorized distributor price book for Eaton's Crouse-Hinds standard Terms and Conditions.

LED System:

- High intensity discrete power emitters
- Cool white (5000K, 70 CRI) and warm white (3000K, 80 CRI)
- Custom optics designed to go over each discrete LED

Standard Materials:

- Lamp housing and adapter – die cast aluminum with Corro-free™ epoxy powder coat
- Lens – heat- and impact-resistant glass
- Gaskets – silicone
- External hardware – stainless steel
- Factory-sealed, no external seals required

Electrical Ratings:

	PVM3L	PVM5L	PVM7L	PVM9L	PVM11L
Voltage Range, VAC	120-277	120-277	120-277	120-277	120-277
Frequency	50 / 60 Hz	50 / 60 Hz	50 / 60 Hz	50 / 60 Hz	50 / 60 Hz
Input Power (Watts)	41	67	94	114	118
Input Amps at 120-277 VAC	0.34-0.17	0.57-0.29	0.80-0.42	0.96-0.49	0.96-0.49
Voltage Range, VDC	108-250	108-250	108-250	108-250	108-250
Power Factor	>0.90	>0.90	>0.90	>0.90	>0.90
Nominal Lumens† (Type V)	3,515	5,288	7,404	9,515	10,935

†Tolerance +/- 10%.

Custom Optics:

Three optical options to maximize light distribution and intensity:

TYPE I

Ideal for:

- Mining conveyor belts
- Aisleways and hallways
- Catwalks and walkways
- Ramps and loading docks
- Tunnels with overhead mounts

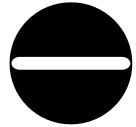

TYPE III

Ideal for:

- Narrow crosswalks or passages with wall mounted fixtures
- Tunnels with wall mount
- Wall or stanchion mount requiring 180° forward throw beam patterns



TYPE V

Ideal for:

- Pendant, ceiling or stanchion mount overhead building mounts
- Processing mills, industrial plants, large buildings, warehouses, etc.



Drivers:

Option	3L - 11L
/UNV1	120-277 VAC, 50 / 60 Hz
/UNV34**	347-480 VAC, 50 / 60 Hz
/VDC‡	108-250 VDC, 50 / 60 Hz

**No separate external transformer required to step down voltage.

‡Separate driver for DC applications.

Ideal for general high bay/low bay illumination

Design Features:

- Ⓐ Installation and replacement made simple - this contractor-friendly, modular design is ideal for both retrofit and new construction applications. These luminaires are installed in the same manner and use the same mounting modules as existing Champ® Series luminaires. The compact modular design of the PVML allows for easy component replacement and future upgrade.
- Ⓑ High efficiency and lumen output - custom high efficiency LED drivers are designed to provide reliable operation in even the harshest environments. Various AC and DC input voltage options are available to suit virtually any drive requirement.
- Ⓒ Safe, reliable heat transfer - die cast aluminum housing provides safe and effective heat transfer from the LED assembly to the outside environment, ensuring low LED junction temperature, reliability, and sustained lumen performance. The vertical fin design facilitates air flow and dust shedding. The impact-resistant lens is sealed from the outside environment and provides ingress protection against water and dust.
- Ⓓ Custom optics - custom optics designed for discrete LED power emitters.
- Ⓔ Ease of wiring and installation - available with lever lock connectors and standard three-pole terminal block for ease of wiring and installation.



Custom Optics:

Custom optics designed for discrete LED power emitters:

- Type V standard
- Type I and Type III optional

Colored LED Options:

- Available in red, blue, green and amber
- Reduction in light pollution for night space observation and sky glow due to isolating blue wavelength in red and amber colors
- Wildlife friendly
- Improves visibility for telescopes in observatories during night sky space exploration



Type I



Type III

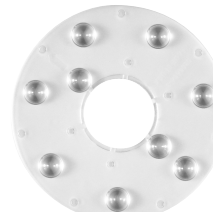

Type V

Options:

Description

Description	Suffix
Wire guard with captive mounting hardware	P3001
Trunnion mount with redundant pin locking mechanism (ceiling mount required)	S812 K1
Quick Clip for quick installation	S890
Diffused lens for glare reduction††	S891
Teflon coating on lens for additional shatter protection††	S896
Polycarbonate lens available in applications where glass is prohibited	S903
Six-pole terminal block††	TB6

††Not available for IEC applications.

Accessories (Ordered Separately):

Description

Description	Cat. # (Ordered Separately)
Photocell, 120V, 50 / 60 Hz	D2S20
Photocell, 208-277V	D2S208 277
Occupancy sensor, 1/2" entry, 120/277 VAC***	COS1/UNV1
Occupancy sensor, 3/4" entry, 120/277 VAC***	COS2/UNV1
Occupancy sensor, 1" entry, 120/277 VAC***	COS3/UNV1

***For 347-480 VAC, replace /UNV1 with /UNV34.

Champ® Pro PVM Series Luminaires

UL/cUL Listed
Type 4X
IP66

2L

Ideal for general high bay/low bay illumination

Catalog Numbering System:

PVM **7L** **W** **2A** **R1** **G** **/UNV1** **S890**

Lamp/Function	
3L	3,515 Lumen LED
5L	5,288 Lumen LED
7L	7,404 Lumen LED
9L	9,519 Lumen LED
11L	10,935 Lumen LED
RL	Red (3,200 Lumen)
GL	Green (4,300 Lumen)
BL	Blue (2,100 Lumen)
AL	Amber (5,000 Lumen)

Color Temperature	
BLANK	Cool (5000 ± 200K)
W	Warm (3000K ± 200K)

Guard	
BLANK	No Guard
G	P3001 Wire Guard

Voltage	
/UNV1	120-277 VAC, 50/60 Hz
/UNV34	347-480 VAC, 50/60 Hz
/VDC	108-250 VDC, 50/60 Hz

Suffixes	
S812	Trunnion Mount Kit with Pin
S890	Quick Clip
S891	Diffused Lens†
S896	Teflon Coated Lens†
S903	Polycarbonate Lens
TB6	Six-pole Terminal Block†

Mounting Style	
BLANK	No Cover
J	1-½" Stanchion 25°
P	1-½" Stanchion Straight
2A	¾" Pendant
3A	1" Pendant
2B	¾" Cone Pendant
3B	1" Cone Pendant
2C	¾" Ceiling
3C	1" Ceiling
2HA	¾" Flexible Pendant
2TW	¾" Wall
3TW	1" Wall

Optics	
BLANK	Type V Optic Standard (All Mounts)
R1	Type I Optic (All Mounts Minus Ceiling)
R1A	Type I Optic (Ceiling with Conduit 45° Counterclockwise or 135° Clockwise from Hinge)*
R1B	Type I Optic (Ceiling with Conduit 45° Clockwise or 135° Counterclockwise from Hinge)*
R3	Type III Optic (All Mounts Minus Ceiling)
R3A1	Type III Optic (Ceiling with Conduit 45° Counterclockwise from Top Hat Hinge)**
R3A2	Type III Optic (Ceiling with Conduit 135° Clockwise from Top Hat Hinge)**
R3B1	Type III Optic (Ceiling with Conduit 45° Clockwise from Top Hat Hinge)**
R3B2	Type III Optic (Ceiling with Conduit 135° Counterclockwise from Top Hat Hinge)**

*For new construction, order R1A only.
**For new construction, order R3A1 only.
†Not available for IEC applications.

Dimensions:

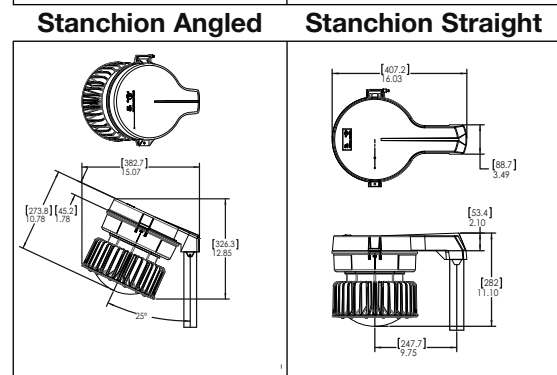
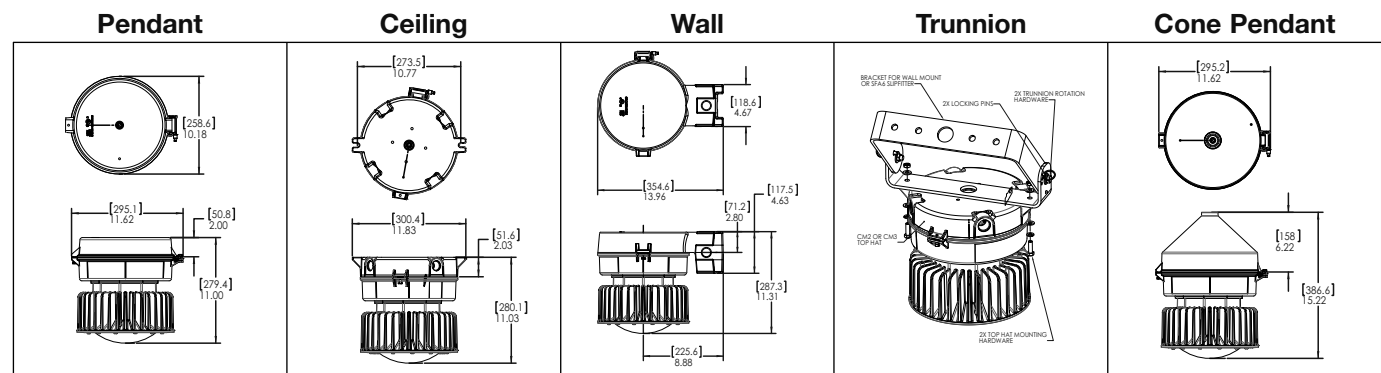

Weights:

Net Luminaire Weight:	21.8 lbs.	8.07 kg.
Mounting Module add (lb.)		
Pendant	1.25	0.57
Cone Pendant	4.00	1.81
Flexible Pendant	1.50	0.68
Ceiling	2.75	1.25
Wall	4.50	2.04
Angle Stanchion	3.50	1.59
Straight Stanchion	4.50	2.04

Crouse-Hinds
by **E.T.N.**

Ideal for general high bay/low bay illumination

Family Tree:

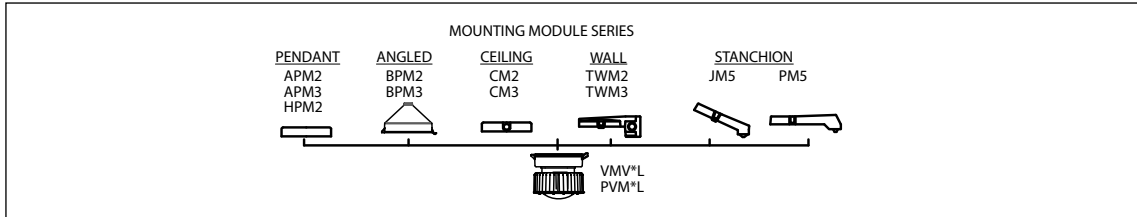

Photometric Data:

Photometric Layout Comparison - Champ® PVM7L LED Versus 175W Metal Halide:

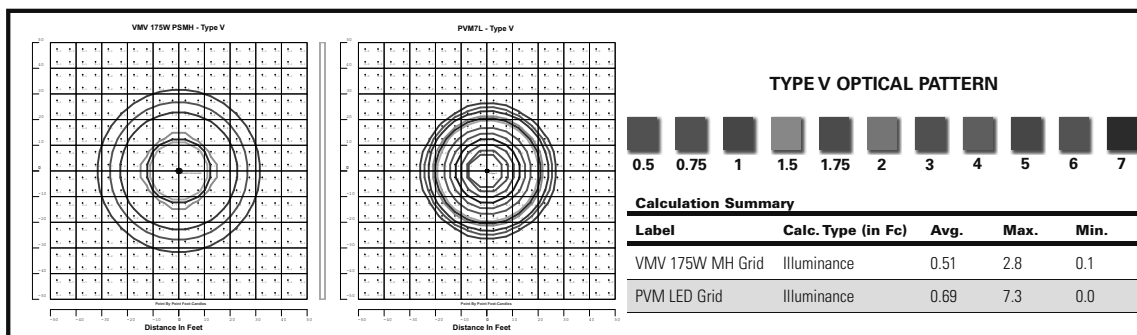
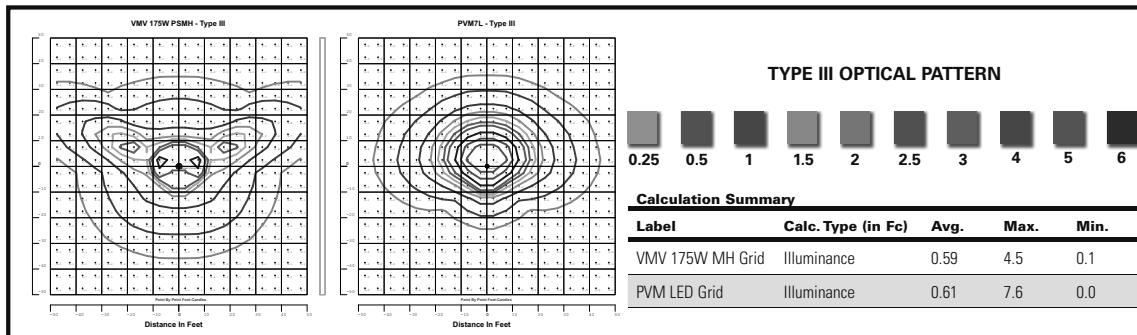
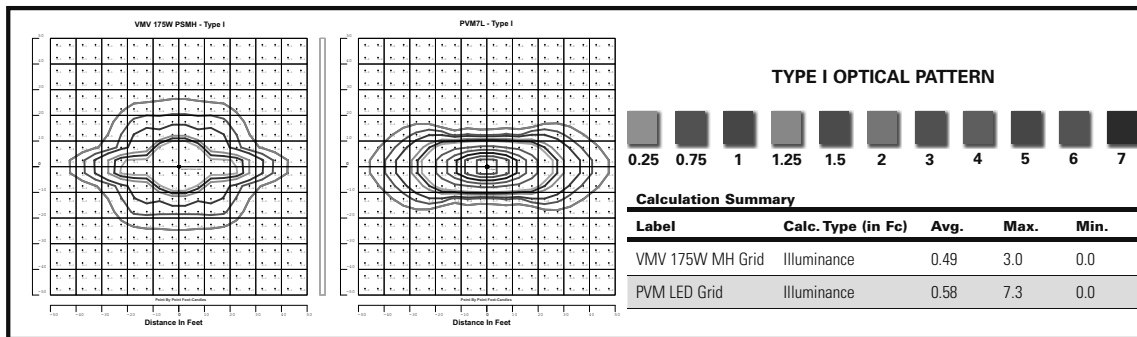

Actual Lumens (Nominal†)	3L	5L	7L	9L	11L
Type I	3,115	4,687	6,562	8,437	9,692
Type III	3,271	4,921	6,890	8,859	10,177
Type V	3,515	5,288	7,404	9,519	10,935

†Tolerance +/- 10%.

Champ® Pro PFM Series Luminaires

UL/cUL Listed
NEMA 4X
IP66

2L

Perfect for outdoor/indoor flood illumination

The Champ® Pro PFM Family

Champ® Pro PFM Series Floodlights are designed to provide full-spectrum, crisp, white light. Five versions of the Champ PFM LED are available, providing ideal solutions for a wide range of applications.

Champ® Pro PFM Model	Equivalent MH HID Lamp	Energy Savings
PFM5L	100W-150W	Up to 62%!
PFM7L	150W-175W	
PFM9L	175W-250W	
PFM11L	250W-400W	
PFM13L	400W	

Certifications and Compliances:

- UL1598
- UL1598A
- cUL
- NEMA 4X; IP66
- DesignLights Consortium® approved for select models (refer to Ordering Information for details)

Drivers:

Model	5L - 13L
Standard	90-305 VAC, 50 / 60 Hz; 108-250 VDC
Option 1	347 VAC Model
Option 2	480 VAC Model

Standard Materials:

- Housing – copper-free aluminum with Corro-free™ epoxy powder coat
- Lens – shatter-resistant glass
- Gaskets – silicone
- External hardware – stainless steel
- Factory-sealed, no external seals required

LED System:

- High brightness light emitting diode (LED) arrays
- Color temperature: 3000K (CRI 82) and 5600K (CRI 65) options available
- Advanced heat sink design ensures LED does not exceed manufacturer's temperature ratings across all specified ambient conditions



Electrical Ratings:

	PFM5L	PFM7L	PFM9L	PFM11L	PFM13L
Voltage Range, VAC	100-277V 50-60 Hz				
	347 / 480V 60 Hz				
Voltage Range, VDC	108-250	108-250	108-250	108-250	108-250
Input Power (Nom.)	64	89	121	149	179
Input Amps (Max.)	0.550	0.800	1.083	1.608	1.608
Power Factor	>0.85	>0.85	>0.85	>0.85	>0.85

Ordering Information:

Color Temperature	5L Series	7L Series	9L Series	11L Series	13L Series
Cool Color Temperature	PFM5LCY/UNV1 76	PFM7LCY/UNV1 76	PFM9LCY/UNV1 76	PFM11LCY/UNV1 76	PFM13LCY/UNV1 76
	PFM5LCY/120 76*	PFM7LCY/120 76*	PFM9LCY/120 76*	PFM11LCY/120 76*	PFM13LCY/120 76*
Warm Color Temperature	PFM5LWY/UNV1 76	PFM7LWY/UNV1 76	PFM9LWY/UNV1 76	PFM11LWY/UNV1 76	PFM13LWY/UNV1 76

For 347 VAC option, replace /UNV1 with /347. For 480 VAC option, replace /UNV1 with /480.

To order fixture without optics, remove '76' from the end of the catalog number.

*5 year limited warranty. Refer to page 2 of the D-0413 authorized distributor price book for Eaton's Crouse-Hinds standard Terms and Conditions. DesignLights Consortium approved models. Cool white only.

Options:

Description	Suffix
Fused (only applies to UNV1 model, not available for 347V or 480V; NOT marine or cUL Listed)	S658
Two conduit/cable glands of like thread installed	S886

Accessories:

Description	Catalog No. Sold Separately
Bolt-on visor (sold separately)	DSV1
Bolt-on wire guard (sold separately)	P61
Floodlight slipfitter (sold separately)	SFA6
Slipfitter wall mount adapter (sold separately)	SWB6

Crouse-Hinds

by E.T.N

2L

2L

Champ® Pro PFM Series Luminaires

UL/cUL Listed
NEMA 4X
IP66

Perfect for outdoor/indoor flood illumination

Dimensions:

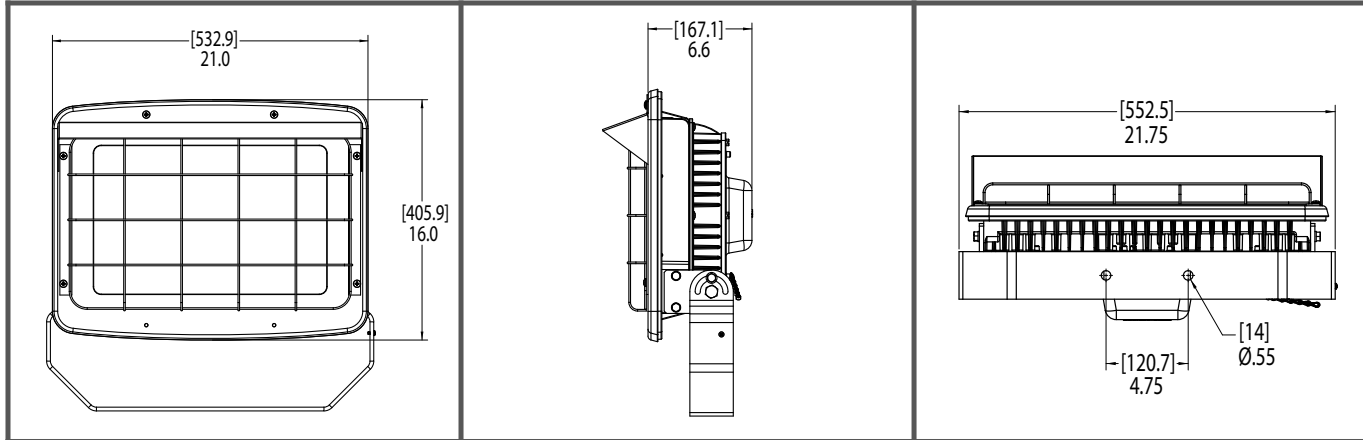

Weights:

Model	Lbs.
5L	39.11
7L	39.16
9L	39.73
11L	40.35
13L	40.35

Ambient Temperature:

Champ® Pro PFM Model	Max. Temp. °C
PFM5L	55
PFM7L	55
PFM9L	55
PFM11L	40
PFM13L	55

Photometric Data:

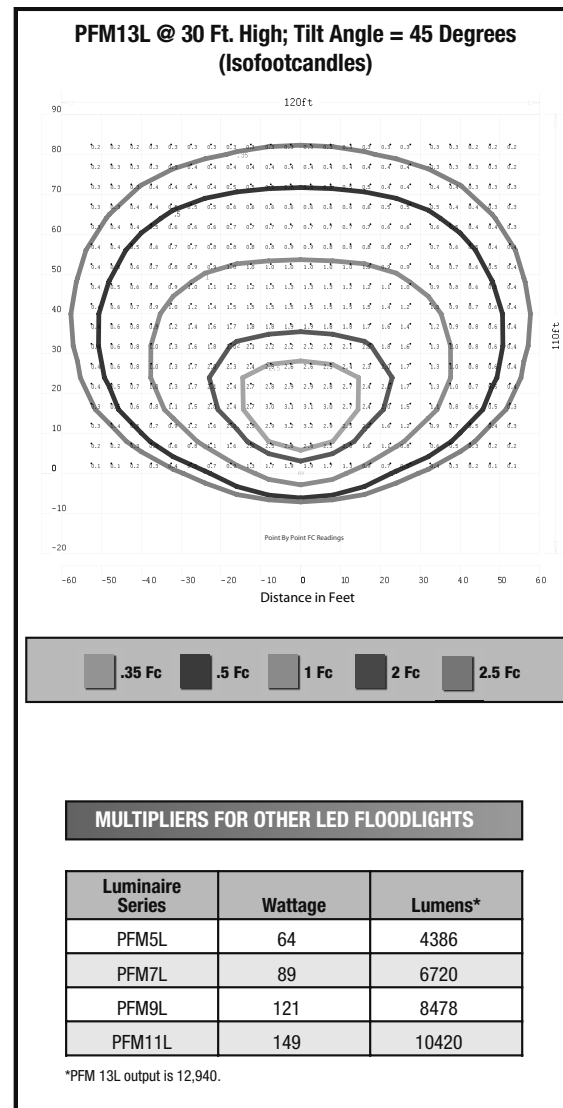

2L

Champ® Pro PFM Series 25L and 50L LED Floodlights

UL/cUL Listed
NEMA 4X
IP66

2L

The Champ® Pro PFM LED Family

PFM LED Series Floodlights are designed to provide full-spectrum, crisp, white light. Two versions of the Champ Pro PFM LED are available, providing ideal solutions for a wide range of applications.

PFM Model	Equivalent HID Lamp	Energy Savings
PFM25L	750W MH	Up to 65%!
PFM50L	1500W MH / 1000W HPS	

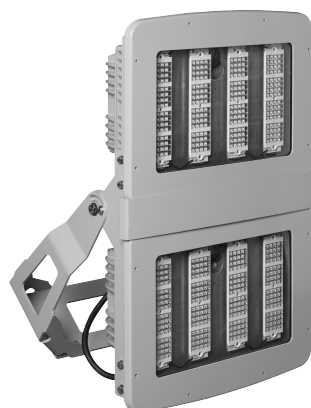

PFM50L Model



PFM25L Model

Applications:

- High lumen output for installation in high mounting heights
- Locations requiring continuous and consistent light levels
- Areas requiring frequent on-and-off of lights
- Where extremely corrosive, wet, dusty, hot and/or cold conditions exist; indoors or outdoors
- NEMA 4X, marine, wet locations, and hose-down environments
- Indoor and outdoor area lighting in plants, buildings, and parking areas
- Manufacturing plants; heavy industrial, chemical, petrochemical or pharmaceutical facilities; platforms; loading docks; outdoor mounted general area lighting
- Ball mills, stackers and reclaimers, concentrators, smelters, mine roadways, outdoor processing areas, truck service shops, shovels, and drag lines

Certifications and Compliances:

- UL1598
- UL1598A
- cUL
- NEMA 4X; IP66
- DesignLights Consortium® approved for select models (refer to Ordering Information for details)
- UL approved up to 40°C ambient

Standard Materials:

- Housing – copper-free aluminum with Corro-free™ epoxy powder coat
- Lens – heat- and impact-resistant glass
- Yoke mount (standard) – copper-free aluminum with Corro-free™ epoxy powder coat
- Gaskets – silicone
- External hardware – stainless steel
- Factory-sealed, no external seals required

LED System:

- High brightness light emitting diodes (LEDs)
- Color temperature: 5000K (CRI 67)
- Advanced heat sink design ensures LED does not exceed manufacturer's temperature ratings across all specified ambient conditions
- LM-79, LM-80 reports available upon request

Electrical Ratings:

	PFM25L	PFM50L
Voltage Range, VAC	120-277V 50 / 60 Hz	
Voltage Range, VDC	277-480V 50 / 60 Hz	
Input Power (Nom.)	263	531
Input Amps (Max.)	2.6	5.2
Power Factor	>0.90	

Options:

Description	Suffix
Two conduit/cable glands of like thread installed	S886
Diffused glass lens	S891
Polycarbonate lens.....	S903

Accessories:

Description	Cat. # (Sold Separately)
Bolt-on visor (sold separately).....	DSV1
Bolt-on wire guard (sold separately).....	P61
Floodlight slipfitter (sold separately).....	SFA6*
Slipfitter wall mount adapter (sold separately).....	SWB6*

*Available with PFM25L model only.

Drivers:

PFM Model	25L, 50L
/UNV1	90-305 VAC, 50 / 60 Hz; 127-250 VDC
/UNV34	277-480 VAC Model

Ordering Information:

25L Series†*

PFM25LCY/UNV1 76

NOTE: Available in cool color temperature only. For 277-480 VAC option, replace /UNV1 with /UNV34.

†DesignLights Consortium® approved model at 120-277V.

*PFM25L is DLC approved with a 5 year limited warranty. Refer to page 2 of the D-0413 authorized distributor price book for Eaton's Crouse-Hinds standard terms and conditions.

50L Series

PFM50LCY/UNV1 76

2L

2L

Champ® Pro PFM Series 25L and 50L LED Floodlights

UL/cUL Listed
NEMA 4X
IP66

Safe, reliable heat transfer

The heat sink was designed to perform in high ambient temperatures up to +40°C and as low as -25°C. The thick walls of the castings make for a tough, rugged housing that keeps the internal driver and LED temperatures down, allowing them to perform flawlessly, and protects them from damage. Separated driver and LED housing allows dust to shed from fixture.



High efficiency and lumen output

High efficiency drivers and LEDs provide 100 LPW for reliable low cost operation in industrial environments. Components were chosen to give industry-leading light output from an LED flood. Replaceable drivers and LEDs for ease of maintenance and "no lights out" feature.



Versatile design

Can be used for outdoor or indoor applications, and for a wide range of mounting heights depending on model and light level requirement. Optics were specifically designed to give the familiar and industry-accepted NEMA 7x6 beam light pattern.



Optional equipment (sold separately)

Optional visor offered to control light spill.
Optional wire guard offered to protect lens from damage.
Other options available - consult part numbering guide.

2L

Champ® Pro PFM Series 25L and 50L LED Floodlights

UL/cUL Listed
NEMA 4X
IP66

2L

Dimensions:

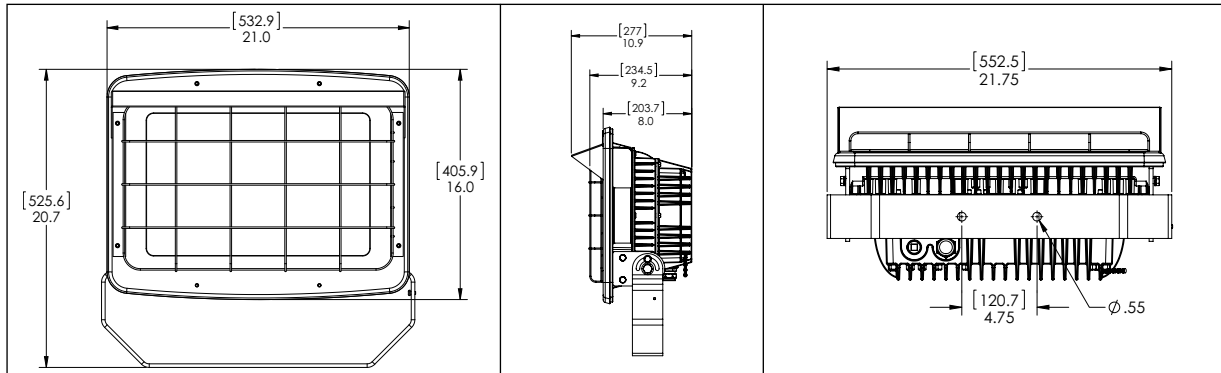

PFM25L Model

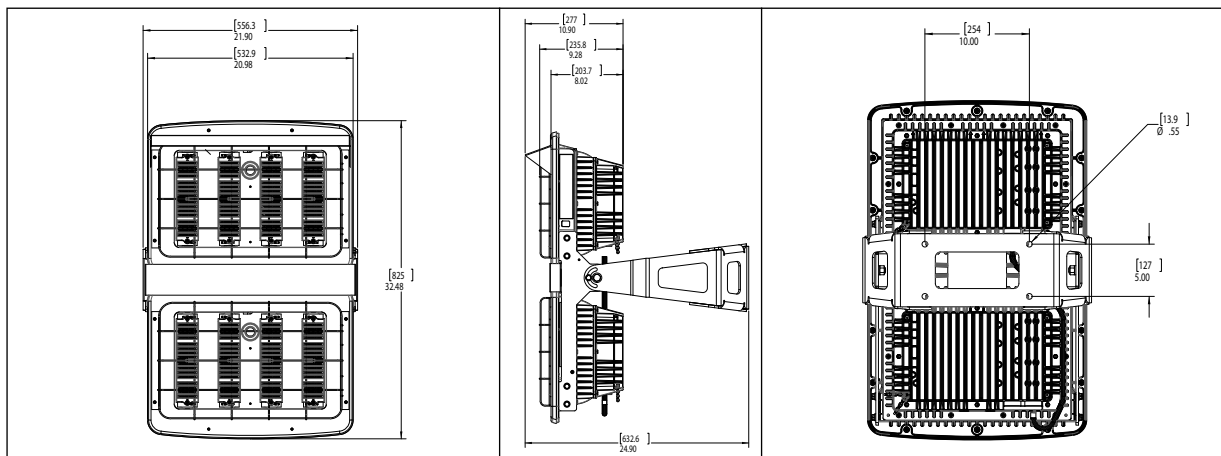

PFM50L Model

Photometric Data:

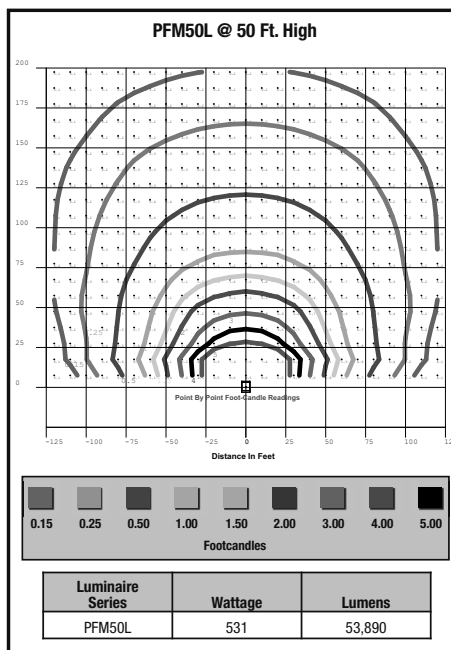
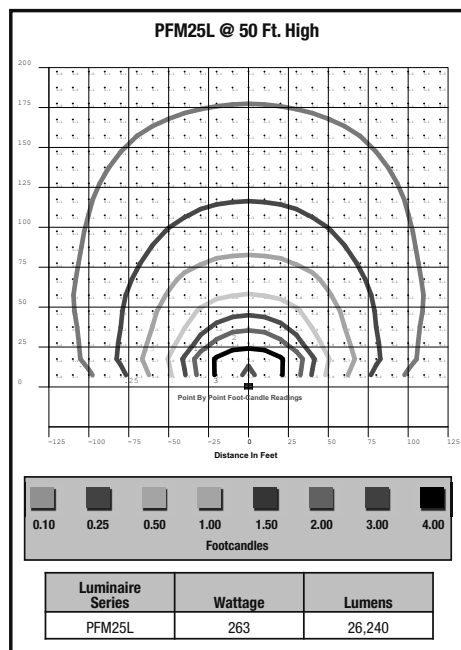

Weights:

PFM Model	Lbs.
PFM25L	52.00
PFM50L	106.00

2L

For targeted illumination in low mounting height areas

The Vaporgard™ Pro P2L Family

P2LC/UNV1 - Cool White Color Temperature

The P2LC/UNV1 Luminaire provides uniform crisp, white light and is suitable for lower mounting heights, confined spaces, tunnels, or utility rooms. Using four high power, high brightness LED arrays, this fixture can deliver similar light levels to 150 watt incandescent.



P2LW/UNV1 - Warm White Color Temperature

The P2LW/UNV1 Luminaire provides similar benefits as the cool white version, but with a color rendering more consistent with a warm incandescent or HPS lamp source. Perfect for situations where Vaporgard Pro will be installed next to a warmer color light source.

DC Power Supply - Available for Applications Requiring DC Power

For applications with DC power requirements such as solar or back-up battery. The DC power supply is suitable for 12VDC through 24VDC.

Certifications and Compliances:

- UL1598
- UL1598A
- cUL
- NEMA 4X; IP66
- DesignLights Consortium® approved for select models (refer to Ordering Information for details)

Electrical Ratings:

	Series			
	P2LC/UNV1*	P2LW/UNV1	P2LC/DC1	P2LW/DC1
Voltage	90-264VAC, 277VAC	90-264VAC, 277VAC	12-24VDC	12-24VDC
Input Power (Watts)	22	22	22	22
Input Current	0.23 / 0.10	0.23 / 0.10	2.1 / 1.0	2.1 / 1.0
Power Factor	>0.9	>0.9	N/A	N/A
THD (I) (%)	<20%	<20%	N/A	N/A
Maintained Lumens	1633	1400	1633	1400
Efficacy, LPW	64	56	64	56
Color Temperature	5600K	3000K	5600K	3000K

*5 year limited warranty. Refer to page 2 of the D-0413 authorized distributor price book for Eaton's Crouse-Hinds standard Terms and Conditions. DesignLights Consortium approved models.

Ordering Information:

Mounting Style	Cool White		Warm White	
	AC Drive**	DC Drive	AC Drive	DC Drive
1/2" Pendant	P2LCA1/UNV1**	P2LCA1/DC1	P2LWA1/UNV1	P2LWA1/DC1
3/4" Pendant	P2LCA2/UNV1**	P2LCA2/DC1	P2LWA2/UNV1	P2LWA2/DC1
1" Pendant	P2LCA3/UNV1**	P2LCA3/DC1	P2LWA3/UNV1	P2LWA3/DC1
1/2" Wall with Junction Box	P2LCHBF1/UNV1**	P2LCHBF1/DC1	P2LWHBF1/UNV1	P2LWHBF1/DC1
3/4" Wall with Junction Box	P2LCHBF2/UNV1**	P2LCHBF2/DC1	P2LWHBF2/UNV1	P2LWHBF2/DC1
1/2" Ceiling	P2LCHF1/UNV1**	P2LCHF1/DC1	P2LWHF1/UNV1	P2LWHF1/DC1
3/4" Ceiling	P2LCHF2/UNV1**	P2LCHF2/DC1	P2LWHF2/UNV1	P2LWHF2/DC1
1/2" VXT Wall	P2LCHT1/UNV1**	P2LCHT1/DC1	P2LWHT1/UNV1	P2LWHT1/DC1
3/4" VXT Wall	P2LCHT2/UNV1**	P2LCHT2/DC1	P2LWHT2/UNV1	P2LWHT2/DC1
1/2" VXW Wall	P2LCHW1/UNV1**	P2LCHW1/DC1	P2LWHW1/UNV1	P2LWHW1/DC1
3/4" VXW Wall	P2LCHW2/UNV1**	P2LCHW2/DC1	P2LWHW2/UNV1	P2LWHW2/DC1
1 1/4" Stanchion	P2LCHJ4/UNV1**	P2LCHJ4/DC1	P2LWHJ4/UNV1	P2LWHJ4/DC1
Adapter Only*	P2LCHR/UNV1**	P2LCHR/DC1	P2LWHR/UNV1	P2LWHR/DC1

*For use when wall mount or ceiling mount box is already installed.

**5 year limited warranty. Refer to page 2 of the D-0413 authorized distributor price book for Eaton's Crouse-Hinds standard Terms and Conditions. DesignLights Consortium approved models. Cool white only.

Standard Materials:

- Body and mounting modules – copper-free aluminum with Corro-free™ epoxy powder coat
- Lens bezel – aluminum with anodized finish
- Lens – heat- and impact-resistant glass
- Gaskets – silicone
- External hardware – stainless steel
- Factory-sealed, no external seals required

LED Array:

- (4) High brightness LED arrays
- Cool white (5600K), CRI 65
- Warm white (3000K), CRI 82
- 70% lumen maintenance (L₇₀) at 50K hours

LED Driver:

- Constant current regulated power supply
- 90VAC - 264VAC, 277VAC, 50 / 60 Hz
- Internal fusing
- Active power factor correction, >0.9
- Low harmonic distortion, <20%
- Low inrush current, <20 amps
- EMC compliant to 47CFR, Part 2, Part 15
- 12VDC / 24VDC option available

Vaporgard™ Pro P2L Series Luminaires

UL/cUL Listed
NEMA 4X
IP66

2L

For targeted illumination in low mounting height areas

Options:

Description	Suffix
Frosted lens reduces glare in applications where the user may have direct visual contact with the light source	S891
Teflon coating on lens provides additional shatter protection for applications in food and beverage facilities	S896
High temperature option allows operation up to 55°C ambient temperature (AC unit only)	S902

Accessories (Order Separately):

Description	Cat. No. Sold Separately
Magnet bracket only (available for ceiling mount VXF20 only)	P2L Magbrk
Magnet bracket kit (includes ceiling mount)	P2L Magbrk K1

Dimensions:

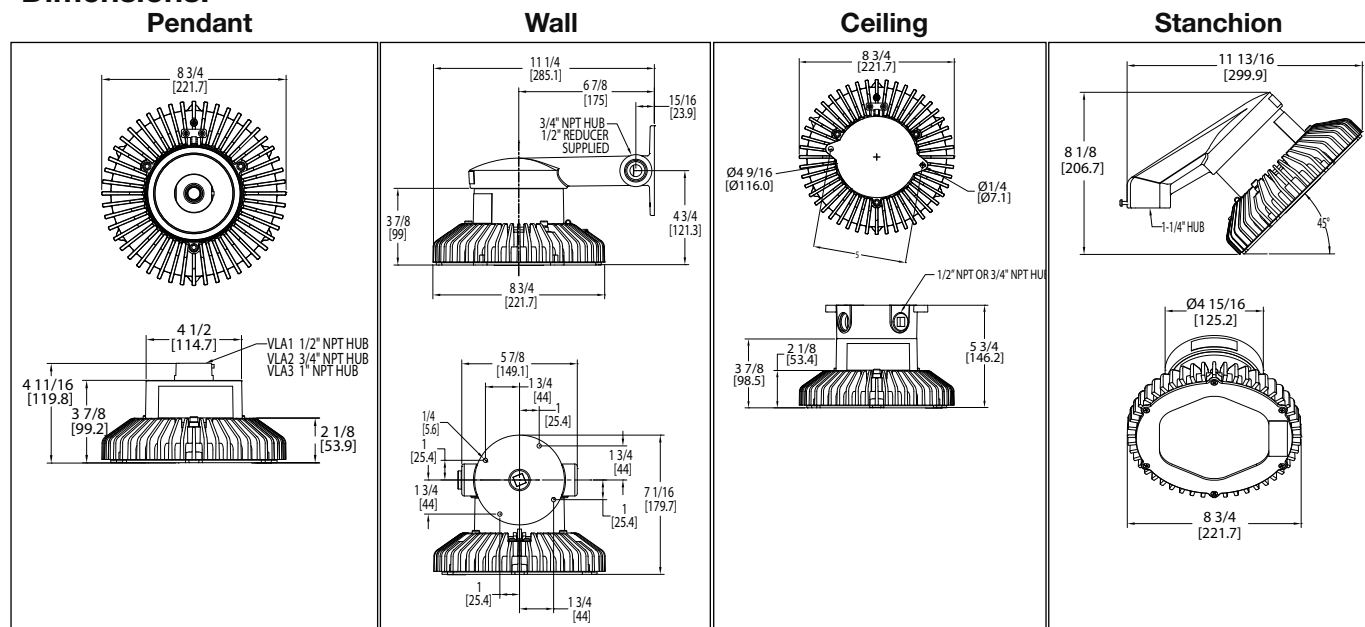

Family Tree:

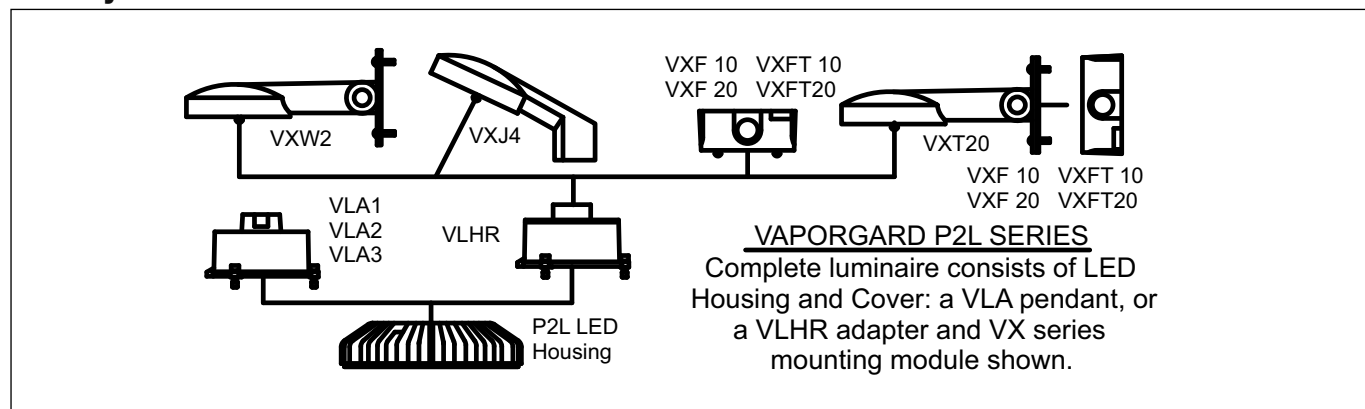

Weights:

Luminaire & Mounting Module Weight	Lbs.
Pendant Mount	5.7
Ceiling Mount	6.8
Wall Mount	7.9
Stanchion Mount	6.5

Ambient Temperature:

Vaporgard™ Pro P2L Model	Max. Temp. °C
P2L/UNV1	40
P2L/UNV1 S902	55
P2L/DC1	40

2L

Vaporgard™ Pro P2L Series Luminaires

UL/cUL Listed
NEMA 4X
IP66

For targeted illumination in low mounting height areas

Photometric Data:

Vaporgard™ Pro LED (22 Watt)

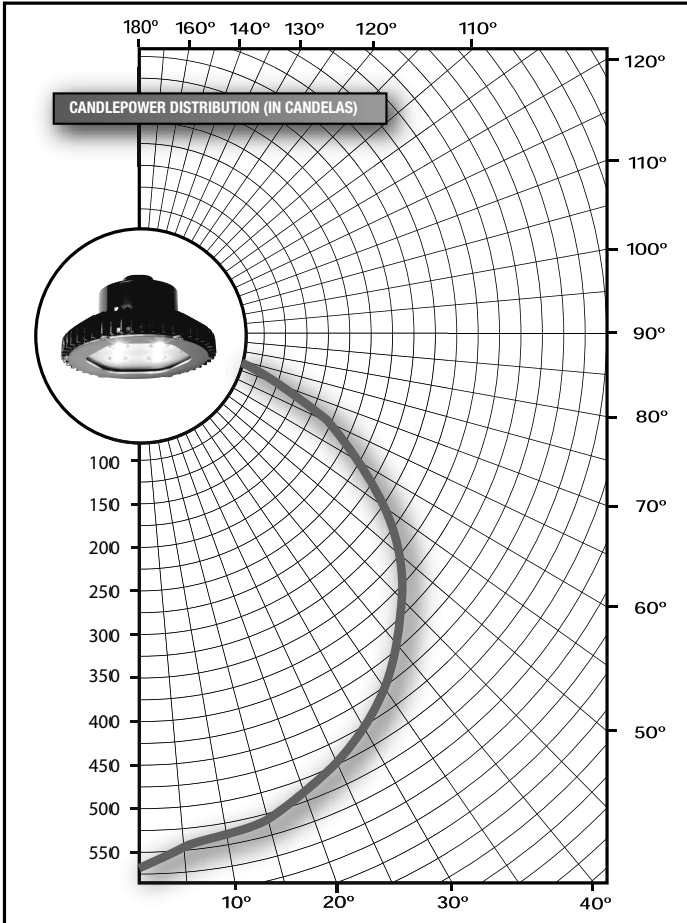

ZONAL LUMENS		
ZONE	LUMENS	% LUMEN
0-30	468	28.65
0-40	772	47.30
0-60	1374	84.15
0-90	1633	100.00
40-90	860	52.70
60-90	259	15.85
90-180	0	0.00
0-180	1633	100.00

DISTANCE TO MOUNTING HEIGHT
Isofootcandle chart shows illuminance in foot-candles at ground level

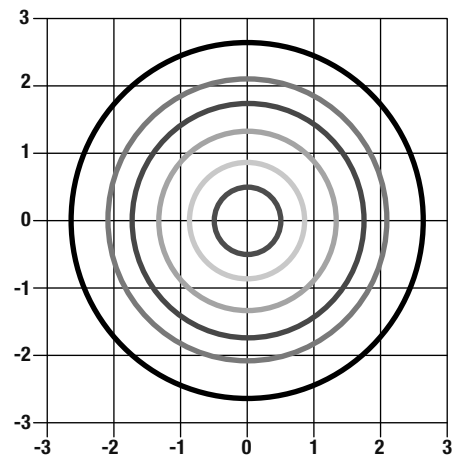

ISOFOOTCANDLE CHART
Footcandle Values for Isofootcandle Lines

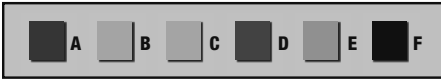

Mtg. Hgt.	A	B	C	D	E	F
6'	10.00	5.00	2.00	1.00	0.50	0.20
8'	5.62	2.81	1.13	0.56	0.28	0.11
10'	3.60	1.80	0.72	0.36	0.18	0.07
12'	2.50	1.25	0.50	0.25	0.13	0.05
14'	1.84	0.92	0.37	0.18	0.09	0.04

2L

Industrial High Bay LED Series Luminaires

Meets UL1598/cUL construction requirements*

2L

Applications:

- Locations requiring continuous and consistent light levels
- Areas requiring frequent on-and-off of lights
- Areas that are difficult to relamp or that cause production to be stopped during the lamp maintenance process
- Ordinary clean, light industrial production facilities, packaging facilities, and warehouses
- Indoor and dry locations only

Features:

- Up to 69% energy savings over 400W metal halide fixtures
- 60,000 hours (rated life) of maintenance-free operation for labor and material savings over the life of the fixture
- Two to three year payback by retrofitting four or six lamp T5HO or 400W metal halide high bay fixtures
- Operating temperature of -30°C to +40°C ambient
- Uniform wide distribution for optimum lighting levels for 18-25 foot mounting heights
- Occupancy sensing control available for enhanced energy savings and lifetime of LED fixture
- Hook and cord attachment for 3/4" pendant hub
- 347-480 VAC driver option

Certifications and Compliances:

- Meets UL1598 and cUL construction requirements*
- DesignLights Consortium®**

*Not UL Listed.

**For /UNV1 model. Refer to page 2 of the D-0413 authorized distributor price book for Eaton's Crouse-Hinds standard Terms and Conditions.

Electrical Ratings:

- 100 VAC to 277 VAC 50 / 60 Hz
- 347 VAC to 480 VAC 50 / 60 Hz

Voltage	P.F.	THD	Amps
120	0.995	8.16%	1.178
277	0.950	12.3%	0.524

Ordering Information:

Cat. #	Description
IHB13L2A/UNV1	Industrial High Bay, 13,940 Lumens, 3/4" Pendant Mount, 100-277 VAC

Note: For 347-480 VAC, replace /UNV1 with /UNV34.

Options:

Description	Suffix
Hook and cord attachment for 3/4" pendant hub	HC

Specifications:

Key Specifications	
Lumens (Typical)†	13,940
Wattage	141W (at 120 VAC); 138W (at 277 VAC)
Lumens Per Watt (LPW)	99
Color Temperature	5,000K
CRI	>70
Voltage Range (VAC)	100-277V, 347-480V; 50 / 60 Hz
Power Factor	0.95 at 277 VAC
Total Harmonic Distortion	12.3% at 277 VAC
Operating Temperature	-30°C to +40°C
Lifetime	60,000 hours at +40°C
Warranty	5 years**

†Tolerance +/- 10%.

**For /UNV1 model. Refer to page 2 of the D-0413 authorized distributor price book for Eaton's Crouse-Hinds standard Terms and Conditions.



Accessories:

Description	Cat. # (Sold Separately)
Occupancy sensor kit, 3/4" entry (sold separately)	IOS2/UNV1‡
Hook and cord kit (sold separately)	IHB HC KIT
Driver replacement kit (sold separately)	IHB PS/ UNV1 KIT

‡For 347-480 VAC, replace /UNV1 with /UNV34.

Dimensions:

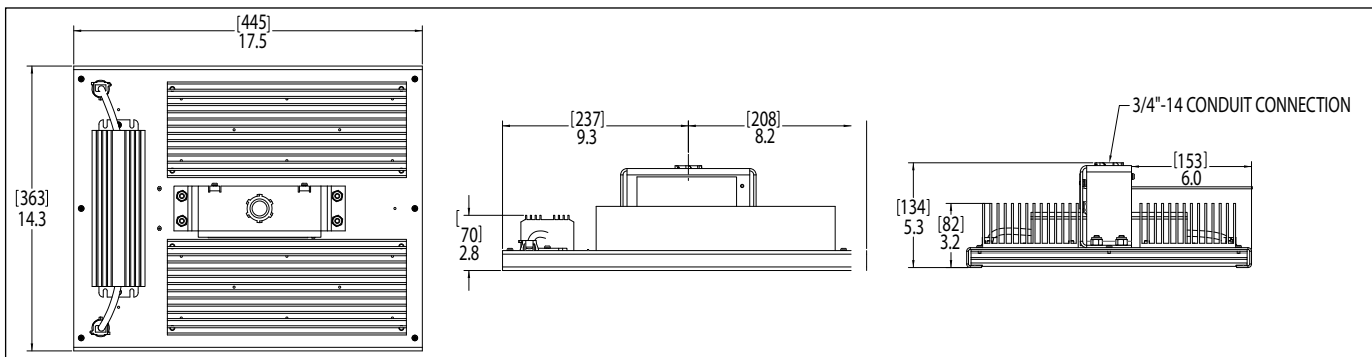

2L

For mining and heavy industrial applications

Endure™ LED Wall Pack Family

The IP66, stainless steel Endure™ LED Luminaire features the patented, modular LED LightBAR™ technology. The Endure LED Luminaire is available with one or two LightBAR configurations in Type II or Type V distributions.

Model	Equivalent HID Output	Energy Savings
FM1 B01	50W HPS	59%
FM1 B02	70W HPS/MH	43%

Applications:

- Ideal for a variety of non-hazardous applications such as mining, food processing, marine, wastewater treatment, heavy manufacturing, and general wash-down areas

Certifications and Compliances:

- UL1598
- cUL
- IP66

LED System:

- Choice of Type II or Type V high efficiency AccuLED™ optics designed to shape light distribution for maximizing efficiency and application spacing
- 50,000+ hour life with >70% lumen maintenance
- 4000K (± 275) CCT and nominal 70 CRI
- 98 lumens per watt; 0.9 power factor

Ordering Information:

PRODUCT FAMILY	NO. OF LIGHTBARS	LAMP TYPE	ELECTRICAL	DISTRIBUTION	LENS	FINISH	ACCESSORIES	OPTIONS
FM1	B01	LED	E1	T2	CTG156	WH	FM1-EBP-WH	316SS

Product Family

FM1 Endure Luminaire

No. of LightBARs

B01 (1) 21 LED LightBAR
B02 (2) 21 LED LightBARs

Lamp Type

LED Solid State Light Emitting Diodes

Electrical

E1 Electronic Driver (1) (120-277V)

Distribution

T2 Type II
5MQ Type V

Lens

CTG156 Clear Tempered Glass, 0.156" Thick
PC125 Clear Polycarbonate, 0.125" Thick
AC125 Clear Acrylic, 0.125" Thick

Finish

WH White Powder Coated Paint
BK Black Powder Coated Paint
BZ Bronze Powder Coated Paint

Accessories

FM1-EBP-WH EM Battery Pack Unit (Coming Soon)
Same dimensions as non-EM unit but with full stainless steel door.
Replace 'WH' in the catalog number with 'BK' or 'BZ' for black or bronze finish.
Includes test switch and indicator light.

Options

316SS Type 316 Stainless Steel Housing and Door

Standard Materials:

- Housing – 16 gauge stainless steel (SS201), painted powder coat white; optional 316 stainless steel housing available for extreme corrosion resistance
- Door – die-formed stainless steel with 0.156" thick clear tempered glass lens; 316 stainless steel (optional)
- Gasket – silicone, around perimeter of glass
- Screws – stainless steel

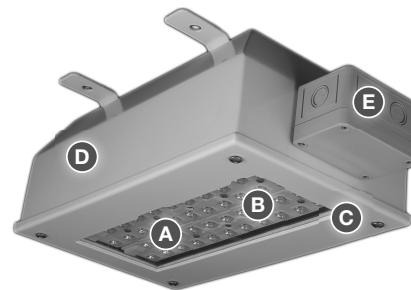

Standard Finish:

- All external components are finished in a polyester white powder coat paint, electrostatically applied

Design Features:

- Ⓐ White light - provides superior color rendering and ambient clarity. Optics are precisely designed to shape the distribution, maximizing efficiency and application spacing.
- Ⓑ Energy efficiency and longer life – 50,000 hours rated life and up to 59% more energy-efficient than the 70W high pressure sodium equivalent.
- Ⓒ Reduction in light pollution – controlled distribution of light means far less light loss.
- Ⓓ IP66 ingress protection rating and -30°C to 50°C ambient temperature rating – ensures trouble-free operation in a variety of harsh and complex applications.
- Ⓔ Junction box – polycarbonate, IP66 rated, four screws to access cover, double row terminal box to expedite installation.

Electrical Ratings:

No. of LightBARs	Distribution				
	Power (Watts)	Current @ 120V(A)*	Current @ 277V(A)*	Lumens (Type II)	Lumens (Type V)
21 LED LightBAR					
1	27	0.23	0.13	2304	2382
2	51	0.43	0.20	4571	4726

*Proprietary circuit module designed to withstand 10kV of transient voltage surge.

For mining and heavy industrial applications

Dimensions:

Top View (2 LightBAR Configuration Shown)

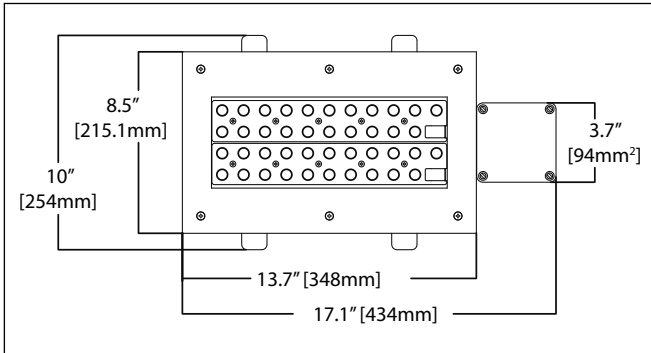

End View

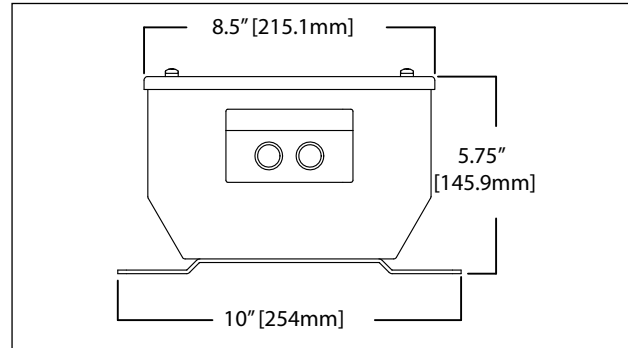

Mounting

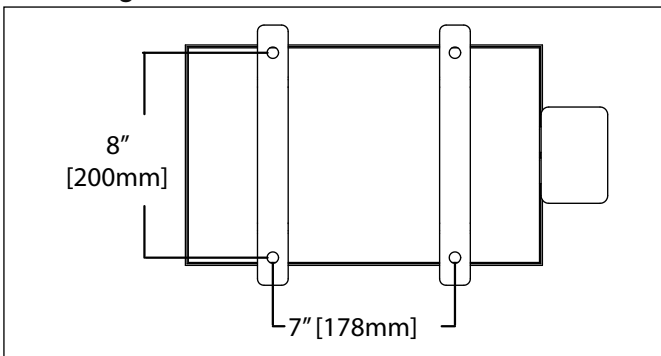

Side View

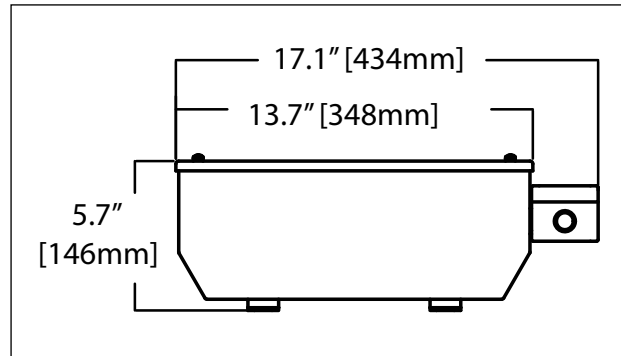

Photometric Data:

Type II Distribution

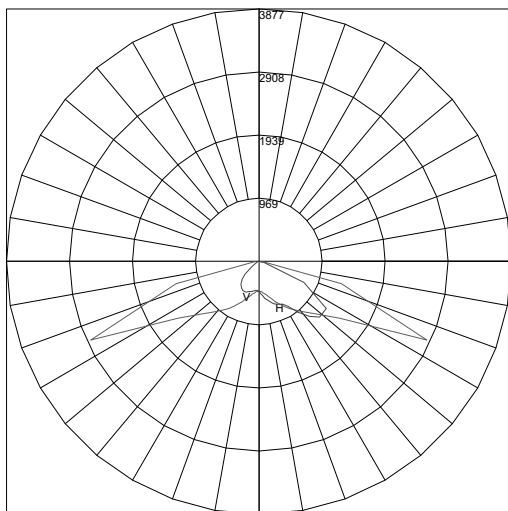

Type V Distribution

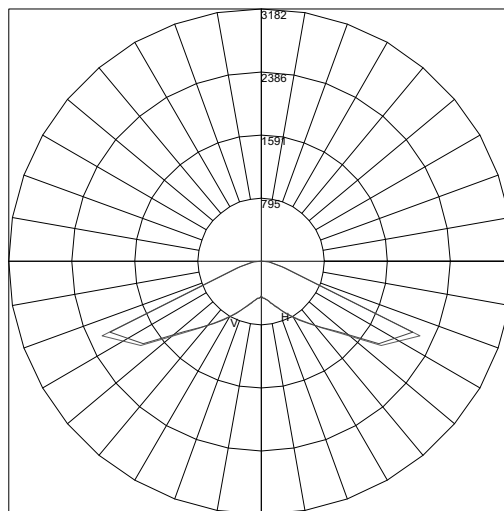

Lumen Multiplier (2 Bar)

Temperature	Multiplier	Lumens
10°C	1.09	5151
15°C	1.03	4868
25°C	1.00	4726
40°C	0.96	4537
50°C	0.92	4348



2L



2L

High Intensity Discharge (H.I.D.) Lighting Hazardous and Non-hazardous

3L

Description	Page No.
Application/Selection	see page 960
Champ® Series – Integrally Ballasted Luminaires	
Accessories	see pages 1022–1023
Ballast Data (USA)	see page 874
Ballast Data (Canada)	see page 874
VMV Series 50 – 175W H.I.D.	see page 962
Catalog Listings	see page 963
Temperature Data, Dimensions, Weights	see page 968
Photometric Data	see pages 970–971
LMV Series 50 – 150W H.I.D.	see page 972
Catalog Listings	see page 973
Temperature Data, Dimensions, Weights	see page 977
Photometric Data	see page 979
DMV Series 50 – 250W H.I.D.	see page 980
Catalog Listings	see page 981
Temperature Data, Dimensions, Weights	see page 986
Photometric Data	see page 988
VMV High Wattage Series 200 – 400W H.I.D.	see page 989
Catalog Listings	see page 990
Temperature Data, Dimensions, Weights	see page 995
Photometric Data	see page 997
VMVIG Series Induction Lighting	see pages 998–1004
DMVIG Series Induction Lighting	see pages 998–1004
N2MV Non-metallic H.I.D.	see page 1005
Catalog Listings	see page 1006
Temperature Data, Dimensions, Weights	see page 1011
Photometric Data	see page 1013
nVMV Ex-Protected Luminaire for IEC and ATEX Applications	see page 1014
Catalog Listings	see page 1015
Temperature Data, Dimensions, Weights	see page 1016
Photometric Data	see pages 1018–1021
Photocells	see page 1024



3L H.I.D. (High Intensity Discharge) Luminaires

Enclosed & Gasketed Application and Selection

Applications:

Luminaires included in this section are enclosed and gasketed, designed for use with H.I.D. lamps as follows:

- In locations where protection is required from wet, dirty and corrosive atmospheres
- Where long life lamps provide desirable maintenance cost savings and return on investment through use of fewer luminaires, circuits and ancillary apparatus
- Where relamping and maintenance difficulties require long life lamps

Considerations for Selection:

Environmental:

- What are the hazardous areas classifications (NEC/CEC) of the locations in which the luminaires will be installed?
- Must luminaires be suitable for use in marine, hosedown, corrosive applications?

Lighting levels required:

- What wattage luminaire(s) will provide the desired light level?

Quick Selector Chart*

Series	Watts HPS, MH & Pulse Start MH Lamps	Hazardous Area & Other Environmental Suitabilities NEC, CEC, IEC	Ballast Voltages
Champ VMV	50, 70, 100, 150, 175 Mogul Base	NEC & CEC Cl. I, Div. 2 Groups A, B, C, D Cl. II, Groups E, F, G Cl. III Simultaneous Presence Restricted Breathing (Suffix – S826) Cl. I, Div. 2 & Zone 2 AEx nR, Ex nR IIC Marine Outdoor & Wet Locations	Standard Voltage Ballasts (60 Hz) NEC (UL) Multi-tap: 120, 208, 240 & 277 Volt 60 Hz. Dual-tap: 120 & 277 Volt 60 Hz (50W HPS) 120 Volt 60 Hz 480 Volt 60 Hz CEC/CSA (cUL) Tri-tap: 120, 277 & 347 Volt 60 Hz Dual-tap: 120 & 277 Volt 60 Hz (50W HPS) 120 Volt 60 Hz
Champ VMV High Wattage	200, 250, 400 Mogul Base		
Champ LMV Low Profile	50, 70, 100, 150 Medium Base	Type 3, 3R, 4, 4X IP56 to IP66	Optional Voltage Ballasts (50 or 60 Hz) CEC/CSA (cUL) 208 Volt 60 Hz CWI – Isolated 240 Volt 60 Hz CWI – Isolated 480 Volt 60 Hz CWI – Isolated 600 Volt 60 Hz CWI – Isolated EXPORT 220 Volt 50 Hz 230 Volt 50 Hz 240 Volt 50 Hz
Champ DMV Expanded Class II Suitability	50, 70, 100, 150, 175, 250 Mogul Base	IEC Certified for IEC Zone 2 (Suffix – S826TB) Ex nR IIC	
Champ N2MV Non-metallic	50, 70, 100, 150, 175 Mogul Base	IP56 to IP66	
Champ nVMV Ex-Protected Luminaire for IEC and ATEX Applications	70 Medium 100, 150 Medium & Mogul 250, 400 Mogul	Zone 2 according to IEC Ex nR II T...Gc Zone 21 and 22 according to IEC Ex t IIIC T...°C Db IP66 IP66 ATEX	220 Volt 50 Hz 230 Volt 50 Hz 240 Volt 50 Hz 220 Volt 60 Hz 230 Volt 60 Hz 240 Volt 60 Hz

*See specific sections for lamp type and wattage suitability.

Champ® H.I.D. Luminaires

**VMV, LMV, DMV, VMV
High Wattage, N2MV & nVMV Series**

Cl. I, Div. 2, Groups A, B, C, D
Restricted Breathing Cl. I,
Div. 2 & Zone 2 (Suffix S826)
Certified for IEC Zone 2
(Suffix S826TB)

Cl. II, Groups E, F, G, Cl. III
Simultaneous Presence
Marine & Wet Locations
3, 3R, 4, 4X; IP56 to IP66

3L

The *Champ* family is an extremely versatile industrial lighting system. Six different series of *Champ* Luminaires embrace a broad range of wattages, lamp sources, compliances, optics, and accessories. Each series is covered in detail on the following pages. General information to help in the proper selection of series and luminaires is shown below.

Applications:

Heavy duty *Champ* lighting luminaires are used:

- In manufacturing plants, refineries, chemical, petrochemical, and other industrial process facilities, waste or sewage treatment facilities, offshore, dockside, and harbor installations, and other heavy industrial applications
- In areas where ignitable concentrations of flammable gases or vapors will be present only due to abnormal, unusual, or accidental conditions
- Where combustible dusts are present
- In marine applications where water spray and corrosive atmospheres are considerations
- In elevated ambient temperatures often found in industrial applications
- In installations where moisture, dirt, dust, vibration, corrosion, and rough usage are problems
- Wherever the damaging effects of water, wind, snow, sleet, hot sun, or any combination of these elements are found

Features:

- Cast copper-free aluminum construction (less than 0.4 of 1% copper) and epoxy powder finish provide excellent resistance to corrosion.
- Seven mounting arrangements in each series, to suit any lighting layout – pendant, flexible pendant, ceiling, wall bracket, angle stanchion, straight stanchion, and quadmount.
- Wide range of light sources and wattages to meet specifiers' needs: 50, 70, 100, 150, 200, 250 and 400 watt high pressure sodium (HPS); 70, 100 175, 250, and 400 watt metal halide (MH and Pulse Start MH).
- Hinged ballast housings for ease of installation and maintenance; all mounting modules fit all ballast housings.
- Wide choice of photometric distributions. Globes available for lamps up through 400 watt HPS, and 250 watt MH. Glass refractors available for all VMV and DMV units; reflector/lens for 200–400 watt VMV units.
- All luminaires are designed to perform in a 40°C ambient temperature. Selected luminaires are suitable for ambient temperatures up to 65°C.



- Superior gasketing seals between the mounting module, housing, and optical assembly for optimum performance in wet and corrosive environments.
- Hubs with an integral conduit stop and bushing to help prevent damage to field wiring during installation.
- Low ambient capability to -40°C.
- Dome and 30° angle reflectors made of bright white *Krydon*® fiberglass-reinforced polyester material provide superior reflectivity, with twist-on feature requiring no tools or additional hardware. Will not chip, peel, dent, rust, or corrode.
- Grounding wire for safety.
- Ballasts are high power factor (min P.F. 90%) and available in a variety of voltages to meet local area requirements.

3L VMV Series 50-175W

Champ® H.I.D. Luminaires

Cl. I, Div. 2, Groups A, B, C, D
Restricted Breathing Cl. I,
Div. 2 & Zone 2 (Suffix S826)
Certified for IEC Zone 2
(Suffix S826TB)

Cl. II, Groups E, F, G, Cl. III &
Simultaneous Presence
(HPS 50W, 70W)
Marine & Wet Locations
3, 3R, 4, 4X; IP56 to IP66

Applications:

VMV series *Champ* luminaires are used:

- In manufacturing plants, refineries, chemical, petrochemical, and other industrial process facilities, waste or sewage treatment facilities, offshore, dockside, and harbor installations, and other heavy industrial applications
- In areas in which ignitable concentrations of flammable gases or vapors will be present only due to abnormal, unusual, or accidental conditions
- Where combustible dusts are present
- In marine applications where water spray and corrosive atmospheres are considerations
- In elevated ambient temperatures often found in industrial applications
- In installations where moisture, dirt, dust, vibration, corrosion, and rough usage are problems
- Wherever the damaging effects of water, wind, snow, sleet, hot sun, or any combination of these elements are found

Features:

- Compact, lightweight design is ideal for medium and low mounting heights
- Cast copper-free aluminum construction (less than 0.4 of 1% copper) and epoxy powder finish provide excellent resistance to corrosion
- Seven mounting arrangements to suit any lighting layout – pendant, flexible pendant, ceiling, wall bracket, angle stanchion, straight stanchion, and quad-mount
- Wide range of light sources and wattages to meet specifiers' needs: 50, 70, 100, and 150 watt high pressure sodium (HPS); 70, 100, 175 watt metal halide (MH and Pulse Start MH)
- Hinged ballast housing for ease of installation and maintenance
- Wide choice of photometric distributions. Glass globes, refractors and compact refractors available for all wattage luminaires; plastic refractors (for non-hazardous applications only) for 50-100 watt luminaires
- All luminaires are designed to perform in a 40°C ambient temperature. Selected luminaires are suitable for ambient temperatures up to 65°C
- Superior gasketing seals between the mounting module, housing, and optical assembly for optimum performance in wet and corrosive environments
- Hubs with an integral conduit stop and bushing to help prevent damage to field wiring during installation
- Low ambient capability to (-40°C)
- Dome and 30° angle reflectors made of bright white *Krydon*® material provide superior reflectivity, with twist-on feature requiring no tools or additional hardware. Will not chip, peel, dent, rust, or corrode
- Grounding wire for safety
- High power factor ballasts (Min P.F. 90%) and available in a variety of voltages to meet local area requirements
- Mogul base porcelain lamp socket



Certifications and Compliances:

- NEC & CEC:
 - Class I, Division 2, Groups A, B, C, D
 - HPS 50W, 70W – Class II, Class III & Simultaneous Presence (Class I, Division 2 and Class II)
 - Class I, Zone 2
- IEC:
 - Zone 2 Ex nR IIC
- UL Standards:
 - 844 Hazardous (Classified) Locations
 - 1598 Luminaires
 - 1598A Marine Locations
- CSA Standards:
 - C22.2 No. 137
- IEC Standards:
 - 60079-15

Standard Materials:

- Ballast housings and mountings – copper-free aluminum (less than 0.4 of 1%)
- Exterior hardware – stainless steel
- Reflectors (dome and angle) – *Krydon* fiberglass-reinforced polyester material
- Globes – heat and impact resistant internally fluted glass
- Refractors – glass (50-175 watts); plastic (50-100 watts), for non-hazardous applications
- Guards: Globe – copper-free aluminum
Refractor – stainless steel

Standard Finishes:

- Copper-free aluminum – epoxy powder coat
- *Krydon* material – high reflectance white
- Stainless steel – natural

Electrical Ratings:

- 120, 208, 240, 277, 347, 480, 600, Multi-tap (120, 208, 240 and 277)
- 50 to 150W HPS; 70 to 175W MH

Options:

The following special options are available from the factory by adding suffix to luminaire Cat. No.:

Description	Suffix
Factory Sealed Champs	S865
Class I, Division 2 & Zone 2 Provides T3 code without conduit or cable seals Restricted breathing/Non-sparking	
Restricted Breathing Construction	S826
Class I, Division 2 & Zone 2 Suitability Cooler Operating Temperatures (T-Numbers)	
Certified for IEC Zone 2	S826TB
Furnished with terminal block, crimp terminals and dedicated voltage ballasts (no MT, DT or TT)	
Fused – to protect ballast and capacitors against abnormal line conditions	S658*
(Not available with /MT Ballast) (Not for use in Canada) (Not suitable for marine applications)	
Quick-Clip - Holds weight of housing when closed. No need to support luminaire while screwing the housing to the cover	S890
Ballast-Gard™ starter cut-out switch – prevents starter pulsing when lamp is cycling or inoperative; prolongs ballast and ignitor life.	
Available for use with 50-150W LX HPS only	BG
Instant restrike – enables a hot HPS lamp to immediately restrike after a momentary loss arc due to voltage fluctuation or power outage. It has no effect on the warm-up period of cold lamps.	
50-150W LX HPS only	IR
50-100W LX HPS only	TIR
Quartz auxiliary lighting – comes to full brightness immediately and remains lit until the HID lamp attains 60-70% of full illumination. For non- hazardous locations only. Must use R2, R3 and R5 refractors.	QTZ
Refractor Mount - For ballast housing only. Used with R2, R3 and R5 refractors.	RM
Stainless steel insert – top hat with stainless steel threaded insert to attach ballast housing	S806
TEFLON coating on globe for increased shatter protection	S808
G24 only. T-Numbers not affected Factory assembled with H.I.D. lamps installed for additional labor savings	FA

Note: BG and IR options cannot be used together. IR and QTZ options cannot be used together.

Accessories:

- See pages 1022-1023 for complete listing.

TEFLON is a registered trademark of E.I. duPont Co.

*When ordering fuses for luminaires, option S658, you must specify the operating voltage. S658 cannot be ordered with /MT in the catalog number.

Crouse-Hinds
by **E.T.N**

VMV Series 50-150W High Pressure Sodium







Champ® H.I.D. Luminaires

Cl. I, Div. 2, Groups A, B, C, D
Restricted Breathing Cl. I,
Div. 2 & Zone 2 (Suffix S826)
Certified for IEC Zone 2
(Suffix S826TB)

Cl. II, Groups E, F, G, Cl. III &
Simultaneous Presence
(50W, 70W)
Marine & Wet Locations
3, 3R, 4, 4X; IP66

3L

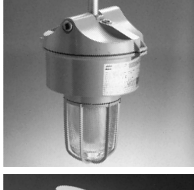
To complete the catalog #, include information in notes 1, 2 and 3 below. For guards and other optics see VMV Series - Ordering By Components page.

Mounting Style	Hub Size	Lamp Watts	BASIC CATALOG NUMBER		
			With G24 Globe and P21 Guard	With G241 Type I Compact Refractor *	With R5 Glass Refractor †
	3/4	50	VMVS2A050GP	VMVS2A050G241	VMVS2A050R5
		70	VMVS3A050GP	VMVS3A050G241	VMVS3A050R5
	1	70	VMVS2A070GP	VMVS2A070G241	VMVS2A070R5
		100	VMVS3A070GP	VMVS3A070G241	VMVS3A070R5
	3/4	100	VMVS2A100GP	VMVS2A100G241	VMVS2A100R5
		150	VMVS3A100GP	VMVS3A100G241	VMVS3A100R5
	3/4	50	VMVS2HA050GP	VMVS2HA050G241	VMVS2HA050R5
	3/4	70	VMVS2HA070GP	VMVS2HA070G241	VMVS2HA070R5
	3/4	100	VMVS2HA100GP	VMVS2HA100G241	VMVS2HA100R5
	3/4	150	VMVS2HA150GP	VMVS2HA150G241	VMVS2HA150R5
	3/4	50	VMVS2C050GP	VMVS2C050G241	VMVS2C050R5
		70	VMVS3C050GP	VMVS3C050G241	VMVS3C050R5
	1	70	VMVS2C070GP	VMVS2C070G241	VMVS2C070R5
		100	VMVS3C070GP	VMVS3C070G241	VMVS3C070R5
	3/4	100	VMVS2C100GP	VMVS2C100G241	VMVS2C100R5
		150	VMVS3C100GP	VMVS3C100G241	VMVS3C100R5
	3/4	50	VMVS2TW050GP	VMVS2TW050G241	VMVS2TW050R5
		70	VMVS3TW050GP	VMVS3TW050G241	VMVS3TW050R5
	1	70	VMVS2TW070GP	VMVS2TW070G241	VMVS2TW070R5
		100	VMVS3TW070GP	VMVS3TW070G241	VMVS3TW070R5
	3/4	100	VMVS2TW100GP	VMVS2TW100G241	VMVS2TW100R5
		150	VMVS3TW100GP	VMVS3TW100G241	VMVS3TW100R5
	3/4	50	VMVS25Q050GP	VMVS25Q050G241	VMVS25Q050R5
	3/4	70	VMVS25Q070GP	VMVS25Q070G241	VMVS25Q070R5
	3/4	100	VMVS25Q100GP	VMVS25Q100G241	VMVS25Q100R5
	3/4	150	VMVS25Q150GP	VMVS25Q150G241	VMVS25Q150R5
	1 1/2	50	VMVSJ050GP	VMVSJ050G241	VMVSJ050R5
		70	VMVSJ070GP	VMVSJ070G241	VMVSJ070R5
	1 1/2	100	VMVSJ100GP	VMVSJ100G241	VMVSJ100R5
		150	VMVSJ150GP	VMVSJ150G241	VMVSJ150R5
	1 1/2	50	VMVSP050GP	VMVSP050G241	VMVSP050R5
		70	VMVSP070GP	VMVSP070G241	VMVSP070R5
	1 1/2	100	VMVSP100GP	VMVSP100G241	VMVSP100R5
		150	VMVSP150GP	VMVSP150G241	VMVSP150R5

* For G243 Type III Compact Refractor, change "241" at end of catalog number to "243". Ex. VMVS2A050G243
For G245 Type V Compact Refractor, change "241" at end of catalog number to "245". Ex. VMVS2A050G245

† For R2 Glass Refractor, change "R5" at end of catalog number to "R2". Ex. VMVS2A050R2.
For R3 Glass Refractor, change "R5" at end of catalog number to "R3". Ex. VMVS2A050R3.

1. Add voltage suffix to end of catalog number
Standard Voltage Ballasts - 60Hz

Voltage Suffix	NEC/UL			CEC/CSA (cUL)		
	Multi Tap /MT	Dual Tap /DT	120V /120	480V /480	Tri Tap /TT	120V /120
	Multi Tap and Dual Tap ballasts are powered for 277V					

Optional Voltage Ballasts - 50 or 60Hz

Voltage Suffix	CEC/CSA (cUL) - CWI Isolated Ballasts				EXPORT		
	208V CWI /208CWI	240V CWI /240CWI	480V CWI /480CWI	600V CWI /600CWI	220V 60Hz /220	220V 50Hz /220 50	240V 50Hz /240 50

2. 150W HPS Luminaires: For 55V lamps - add suffix LX; for 100V lamps - add suffix CE. 50W HPS luminaire is dual tap only.

3. Options - Add the required option suffixes, see page 962, in alpha-numeric order.

Crouse-Hinds
by **EATON**





3L VMV Series 150-175W Pulse Start Metal Halide

Champ® H.I.D. Luminaires

Cl. I, Div. 2, Groups A, B, C, D
 Restricted Breathing Cl. I, Div. 2
 & Zone 2 (Suffix S826)
 Certified for IEC Zone 2
 (Suffix S826TB)

Marine & Wet Locations
 3, 3R, 4, 4X; IP66

To complete the catalog #, include information in note 1 below. For guards and other optics see VMV Series - Ordering By Components page.

	Mounting Style	Hub Size	Lamp Watts	BASIC CATALOG NUMBER		
				With G24 Globe and P21 Guard	With G245 Type V Compact Refractor *	With R5 Glass Refractor †
	Pendant Mount	3/4	150	VMVM2A150GP S828	VMVM2A150G245 S828	VMVM2A150R5 S828
		1	175	VMVM3A150GP S828	VMVM3A150G245 S828	VMVM3A150R5 S828
	Flexible Pendant Mount	3/4	150	VMVM2HA150GP S828	VMVM2HA150G245 S828	VMVM2HA150R5 S828
		3/4	175	VMVM2HA175GP S828	VMVM2HA175G245 S828	VMVM2HA175R5 S828
	Ceiling Mount Thru-Feed	3/4	150	VMVM2C150GP S828	VMVM2C150G245 S828	VMVM2C150R5 S828
		1	175	VMVM3C150GP S828	VMVM3C150G245 S828	VMVM3C150R5 S828
	Wall Mount Thru-Feed	3/4	150	VMVM2C175GP S828	VMVM2C175G245 S828	VMVM2C175R5 S828
		1	175	VMVM3C175GP S828	VMVM3C175G245 S828	VMVM3C175R5 S828
	Wall Mount Thru-Feed	3/4	150	VMVM2TW150GP S828	VMVM2TW150G245 S828	VMVM2TW150R5 S828
		1	175	VMVM3TW150GP S828	VMVM3TW150G245 S828	VMVM3TW150R5 S828
	Quad-Mount Pendant, Adjustable Thru-Feed, 25° Angle, 12 1/2° Angle	3/4	150	VMVM25Q150GP S828	VMVM25Q150G245 S828	VMVM25Q150R5 S828
		3/4	175	VMVM25Q175GP S828	VMVM25Q175G245 S828	VMVM25Q175R5 S828
	Stanchion Mount 25° Angle	1 1/2	150	VMVMJ150GP S828	VMVMJ150G245 S828	VMVMJ150R5 S828
		1 1/2	175	VMVMJ175GP S828	VMVMJ175G245 S828	VMVMJ175R5 S828
	Stanchion Mount Straight	1 1/2	150	VMVMP150GP S828	VMVMP150G245 S828	VMVMP150R5 S828
		1 1/2	175	VMVMP175GP S828	VMVMP175G245 S828	VMVMP175R5 S828

* For G241 Type I Compact Refractor, change "245" at end of catalog number to "241". Ex. VMVM2A150G241-S828
 For G243 Type III Compact Refractor, change "245" at end of catalog number to "243". Ex. VMVM2A150G243-S828

† For R2 Glass Refractor, change "R5" at end of catalog number to "R2". Ex. VMVM2A150R2-S828.
 For R3 Glass Refractor, change "R5" at end of catalog number to "R3". Ex. VMVM2A150R3-S828.

1. Add voltage suffix to end of catalog number

Voltage Suffix	Standard Voltage Ballasts - 60Hz			CEC/CSA (cUL)	
	Multi Tap /MT	120V /120	480V /480	Tri Tap /TT	120V /120
	Optional Voltage Ballasts - 50 or 60Hz EXPORT				
Voltage Suffix	220V 60Hz /220	220V 50Hz /220 50	230V 50Hz /230 50	240V 50Hz /240 50	

VMV Series 70-175W Metal Halide







Champ® H.I.D. Luminaires

Cl. I, Div. 2, Groups A, B, C, D
Restricted Breathing Cl. I,
Div. 2 & Zone 2 (Suffix S826)
Certified for IEC Zone 2 (Suffix S826TB)

Marine & Wet Locations
3, 3R, 4, 4X; IP66

3L

To complete the catalog #, include information in notes 1, 2 and 3 below. For guards and other optics see VMV Series - Ordering By Components page.

	Mounting Style	Hub Size	Lamp Watts	BASIC CATALOG NUMBER		
				With G24 Globe and P21 Guard	With G241 Type I Compact Refractor *	With R5 Glass Refractor †
	Pendant Mount	3/4	70	VMVM2A070GP	VMVM2A070G241	VMVM2A070R5
		1		VMVM3A070GP	VMVM3A070G241	VMVM3A070R5
		3/4	100	VMVM2A100GP	VMVM2A100G241	VMVM2A100R5
		1		VMVM3A100GP	VMVM3A100G241	VMVM3A100R5
		3/4	175	VMVM2A175GP	VMVM2A175G241	VMVM2A175R5
		1		VMVM3A175GP	VMVM3A175G241	VMVM3A175R5
	Flexible Pendant Mount	3/4	70	VMVM2HA070GP	VMVM2HA070G241	VMVM2HA070R5
		3/4	100	VMVM2HA100GP	VMVM2HA100G241	VMVM2HA100R5
		3/4	175	VMVM2HA175GP	VMVM2HA175G241	VMVM2HA175R5
	Ceiling Mount Thru-Feed	3/4	70	VMVM2C070GP	VMVM2C070G241	VMVM2C070R5
		1		VMVM3C070GP	VMVM3C070G241	VMVM3C070R5
		3/4	100	VMVM2C100GP	VMVM2C100G241	VMVM2C100R5
		1		VMVM3C100GP	VMVM3C100G241	VMVM3C100R5
		3/4	175	VMVM2C175GP	VMVM2C175G241	VMVM2C175R5
		1		VMVM3C175GP	VMVM3C175G241	VMVM3C175R5
	Wall Mount Thru-Feed	3/4	70	VMVM2TW070GP	VMVM2TW070G241	VMVM2TW070R5
		1		VMVM3TW070GP	VMVM3TW070G241	VMVM3TW070R5
		3/4	100	VMVM2TW100GP	VMVM2TW100G241	VMVM2TW100R5
		1		VMVM3TW100GP	VMVM3TW100G241	VMVM3TW100R5
		3/4	175	VMVM2TW175GP	VMVM2TW175G241	VMVM2TW175R5
		1		VMVM3TW175GP	VMVM3TW175G241	VMVM3TW175R5
	Quad-Mount Pendant, Adjustable Thru-Feed, 25° Angle, 12 1/2° Angle	3/4	70	VMVM25Q070GP	VMVM25Q070G241	VMVM25Q070R5
		3/4	100	VMVM25Q100GP	VMVM25Q100G241	VMVM25Q100R5
		3/4	175	VMVM25Q175GP	VMVM25Q175G241	VMVM25Q175R5
	Stanchion Mount 25° Angle	1 1/2	70	VMVMJ070GP	VMVMJ070G241	VMVMJ070R5
		1 1/2	100	VMVMJ100GP	VMVMJ100G241	VMVMJ100R5
		1 1/2	175	VMVMJ175GP	VMVMJ175G241	VMVMJ175R5
	Stanchion Mount Straight	1 1/2	70	VMVMP070GP	VMVMP070G241	VMVMP070R5
		1 1/2	100	VMVMP100GP	VMVMP100G241	VMVMP100R5
		1 1/2	175	VMVMP175GP	VMVMP175G241	VMVMP175R5

* For G243 Type III Compact Refractor, change "241" at end of catalog number to "243". Ex. VMVM2A070G243
For G245 Type V Compact Refractor, change "241" at end of catalog number to "245". Ex. VMVM2A070G245

† For R2 Glass Refractor, change "R5" at end of catalog number to "R2". Ex. VMVM2A070R2.
For R3 Glass Refractor, change "R5" at end of catalog number to "R3". Ex. VMVM2A070R3.

1. Add voltage suffix to end of catalog number
Standard Voltage Ballasts - 60Hz

Voltage Suffix	NEC/UL			CEC/CSA (cUL)	
	Multi Tap /MT	120V /120	480V /480	Tri Tap /TT	120V /120

2. 70W ballast not available in 480V.

3. Options - Add the required option suffixes, see page 962, in alpha-numeric order.

Optional Voltage Ballasts - 50 or 60Hz

Voltage Suffix	CEC/CSA (cUL) - CWI Isolated Ballasts			EXPORT			
	208V CWI /208CWI	480V CWI /240CWI	600V CWI /600CWI	220V 60Hz /220	220V 50Hz /220 50	230V 50Hz /230 50	240V 50Hz /240 50

Crouse-Hinds
by **EATON**

3L VMV Series – Ordering by Components

VMV luminaires are available in components.

A complete luminaire consists of:

- I. Champ Cover (Mounting Module)
- II. VMV Ballast Housing – Include voltage and required option(s)
- III. Optical & Guard components – Globe, Reflector, Refractor, Guard

I. Champ Cover (Mounting Module):

Type	Conduit	Cat. #
Pendant	3/4"	APM2
	1"	APM3
Flexible Pendant	3/4"	HPM2
Ceiling	3/4"	CM2
	1"	CM3
Wall	3/4"	TWM2
	1"	TWM3
Stanchion – 25 Degree Angle	1 1/2"	JM5
Stanchion – Straight	1 1/2"	PM5
Quad-Mount	3/4"	QM25

II. Ballast Housings:

Complete catalog number must have the **voltage suffix** (MT shown) and any **options suffixes**.

Lamp Type	Lamp Watts	Cat. # For Globe and Compact Refractor	Cat. # For Large Refractor
High Pressure Sodium	50	VMVS050/DT	VMVS050/MT RM
	70	VMVS070/MT	VMVS070/MT RM
	100	VMVS100/MT	VMVS100/MT RM
	150	VMVS150/MT LX	VMVS150/MT LX RM
Metal Halide	70	VMVM070/MT	VMVM070/TT RM
	100	VMVM100/MT	VMVM100/MT RM
	175	VMVM175/MT	VMVM175/MT RM

III. Globe, Reflectors, Refractors, Guards:

Type	Cat. #
Globe	G24
Globe – Teflon Coated	G24 S808
Globe Guard	P21
Reflector – Dome	RD70
Reflector – Angle	RA70
Compact Refractor Type 1	G241
Compact Refractor Type 3	G243
Compact Refractor Type 5	G245
Compact Refractor Guard	P241
Large Refractor Type 2	R2
Large Refractor Type 3	R3
Large Refractor Type 5	R5
Large Refractor Guard	P23
Large Plastic Refractor Type 2	PR2
Large Plastic Refractor Type 3	PR3
Large Plastic Refractor Type 5	PR5

Champ® H.I.D. Luminaires

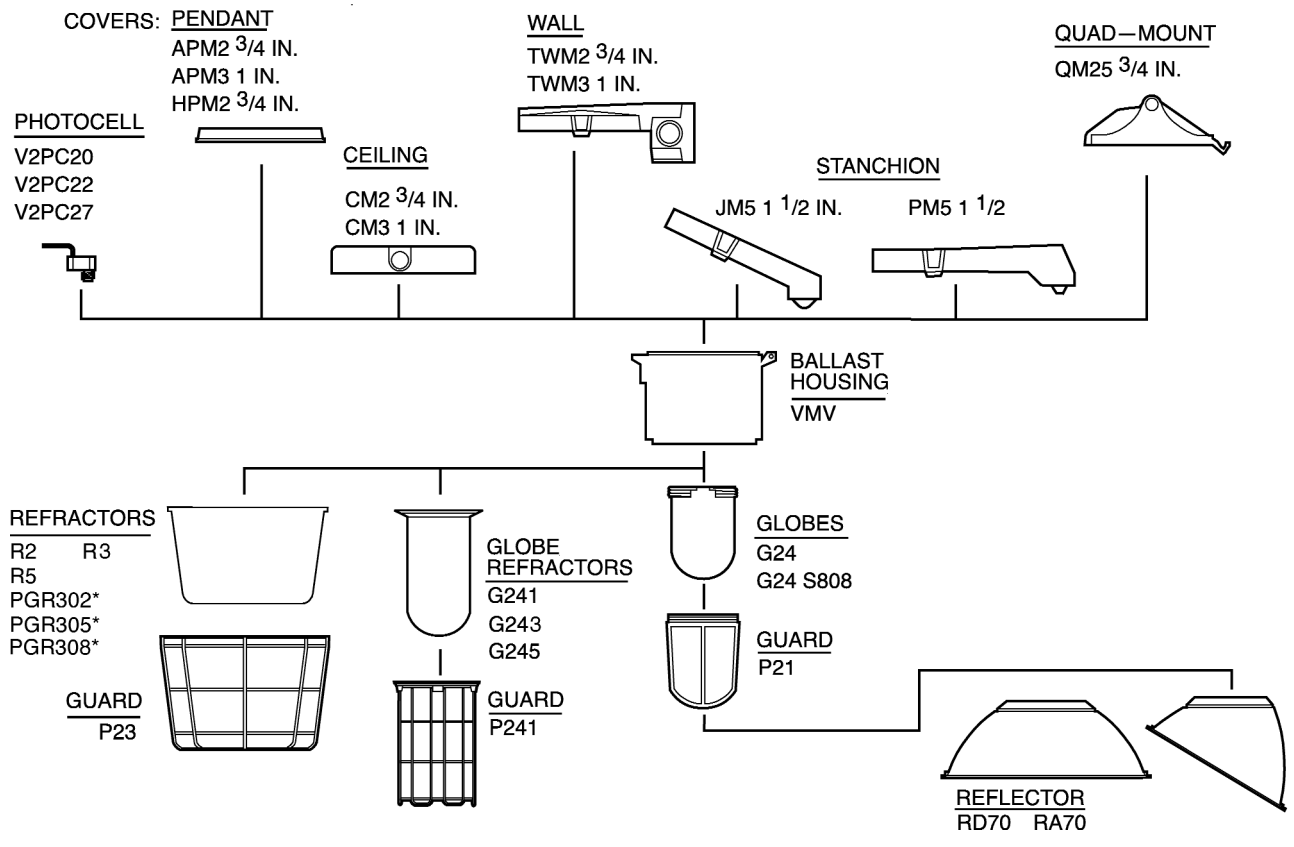

*Plastic refractors are for non-hazardous areas only (50-100W Max.)



Champ® H.I.D. Luminaires

Cat. #	Lamp		Rated Ambient °C	Class I, Division 2				Class II, Division 1	Simultaneous Presence Class I, Div. 2 Class II, Div. 2	Class I, Zone 2		Supply Wire Suitable For °C	
	Wattage	Type		Globe (G24, G241, G245)	Globe (G24) w/ Reflector (RA70 or RD70)	Reflector (R2, R3, or R5)	Group			Globe (G24) w/ or w/o Reflector (RA70 or RD70)	Restricted Breathing Suffix S826 w/ Globe (G24, G241, G245)	Factory Sealed Suffix S865 AEx nA nR II	Globe (G24, G241, G245)
VMVM70	70	MH	40	T3A	T3A	T3A				T5	T3	90	90
VMVM70	70	MH	55	T3	T3	T3				T4	T3	90	90
VMVM70	70	MH	65	T3	T3	T3				T4	T3	90	90
VMVM100	100	MH	40	T2D	T2D	T2D				T4	T3	90	90
VMVM100 S849	100	MH	40	T2	T2	T2				T4	T3	75	75
VMVM100	100	MH	55	T2D	T2D	T2D				T4	T3	90	90
VMVM150	150	MH	40	T2A	T2A	T2B				T3	T3	90	90
VMVM175	175	MH	40	T2A	T2A	T2B				T3	T3	90	90
VMVS50	50	HPS	40	T3A	T3A	T3B	EFG	T4A	T3A	T5	T3	75	65
VMVS50	50	HPS	55	T3A	T3A	T3A	EFG	T4	T3	T5	T3	75	75
VMVS50	50	HPS	65	T3	T3	T3	EFG	T4	T2D	T5	T3	75	75
VMVS70	70	HPS	40	T3	T3	T3B	EFG	T3C	T2C	T4	T3	75	65
VMVS70	70	HPS	55	T3	T3	T3	EFG	T3C	T2B	T4	T3	90	90
VMVS100	100	HPS	40	T2C	T2C	T2D	EFG	T3A	T2A	T4	T3	90	75
VMVS100	100	HPS	55	T2B	T2B	T2C	EFG			T3	T3	105	90
VMVS150	150	HPS	40	T2A	T2A	T2B				T3	T3	90	85
VMVS150	150	HPS	55	T2	T2	T2A				T3	T3	105	105
VMVIG055	55	Induction	40	T2C	T2C	—				T6	—	65	—
VMVIG055	55	Induction	55	T2C	T2C	—				T5	—	65	—

The Class I, Division 2 T-codes apply to luminaires without the restricted breathing (S826) or factory sealed (S865) options. These luminaires are listed to UL 844. UL844 specifies how the temperatures are measured.

The Class I, Zone 2 T-codes are for luminaires that are additionally listed to UL 60079-15 that specify a different method for measuring temperatures. Since NEC® 501.1 states that equipment "...for use in Class I, Zone 0, 1, or 2 locations shall be permitted in Class I, Division 2 locations..." then these luminaires are suitable for Class I, Division 2 but with cooler temperature ratings. They also have the advantage of meeting the more rigorous mechanical tests of UL 844.



Champ® H.I.D. Luminaires

**Dimensions
In Inches:**

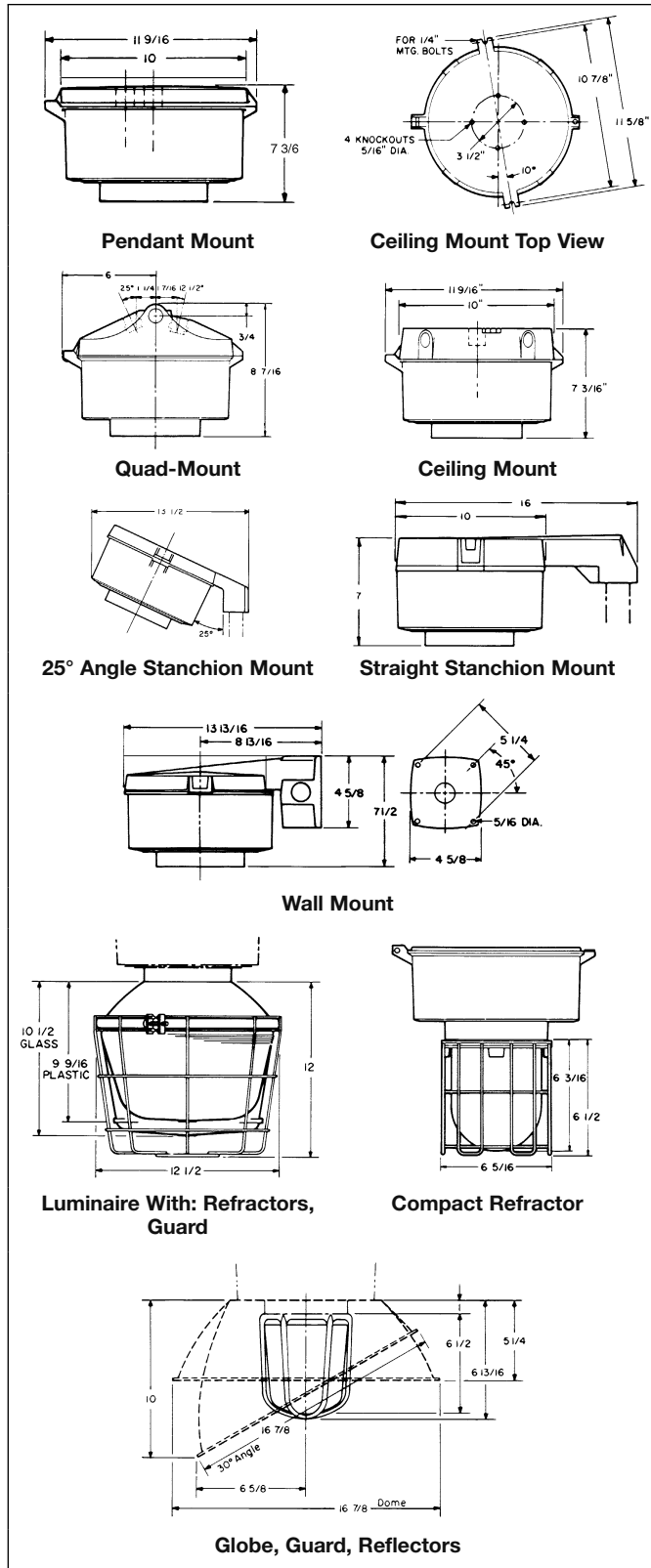

Net Luminaire Weights:

Luminaire Series	Lamp Watts				
	50	70	100	150	175
Luminaire with Globe, Guards (lbs.):					
VMVS	13 1/2	14 1/2	14 1/2	14 1/2	
VMVM		13	13 1/4		15 1/2
Luminaire with Glass Refractor (lbs.):					
VMVS	21 3/4	22 3/4	22 3/4	22 3/4	
VMVM		21	21 1/2		23 3/4

Type	Lbs.	Type	Lbs.
Add for mounting modules:			
Pendant	1 1/4	Quad-Mount	3 1/2
Flexible Pendant	1 1/2	Angle Stanchion	3 1/2
Ceiling	2 3/4	Straight Stanchion	4 1/2
Wall	4 1/2		
Add for reflectors:			
Dome	1 1/2	30° Angle	1 1/2

Deduct: 1/2" lb. for fixture without P21 Guard

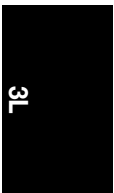

Champ® H.I.D. Luminaires

Lamp: 100W/E – 23½ high pressure sodium (HPS)
 Total bare lamp lumens: 9500

NOTE: All data provided is for high pressure sodium luminaires with 100W/E-23½ clear lamps. Use conversion factors (multipliers) shown below for other clear lamp types and wattages. Consult Eaton's Crouse-Hinds for additional photometric data on any Champ Series luminaire.

Luminaire with Globe and Dome Reflector

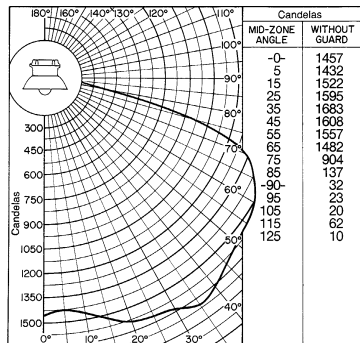

Multipliers (for use with candela curve only).

Luminaire Series	Lamp Watts	Conversion Factor
	50	0.42
VMVS	70	0.67
	150	1.68

Luminaire spacing ratio: 1.85

Coefficient of Utilization

Effective Floor Cavity Reflectance 20%

% Reflectance Eff. Ceil.	Room Cavity Ratio	Room Cavity Ratio				
		1	2	3	4	5
80	50	.823	.707	.610	.529	.464
	30	.784	.646	.538	.451	.384
	10	.749	.594	.482	.391	.324
70	50	.804	.690	.597	.517	.452
	30	.767	.633	.530	.445	.377
	10	.734	.587	.477	.388	.321
50	50	.765	.658	.571	.494	.434
	30	.735	.611	.513	.431	.368
	10	.709	.569	.466	.381	.318
30	50	.731	.629	.546	.473	.416
	30	.708	.591	.497	.419	.357
	10	.685	.555	.456	.375	.312
10	50	.701	.603	.524	.454	.399
	30	.681	.569	.482	.406	.348
	10	.662	.541	.446	.367	.307
0	0	.644	.521	.427	.348	.288
% Reflectance Eff. Ceil.	Room Cavity Ratio	Room Cavity Ratio				
		6	7	8	9	10
80	50	.412	.366	.326	.296	.258
	30	.334	.290	.253	.224	.187
	10	.278	.239	.201	.175	.142
70	50	.403	.359	.320	.291	.252
	30	.329	.285	.250	.221	.187
	10	.274	.235	.200	.174	.142
50	50	.386	.344	.307	.279	.244
	30	.320	.277	.244	.216	.182
	10	.271	.231	.197	.172	.140
30	50	.371	.329	.296	.269	.235
	30	.312	.272	.237	.210	.178
	10	.267	.227	.195	.170	.137
10	50	.357	.319	.285	.260	.227
	30	.304	.266	.232	.206	.173
	10	.263	.224	.192	.167	.135
0	0	.245	.207	.176	.152	.120

Isofootcandle Chart: Luminaire with Globe and Dome Reflector

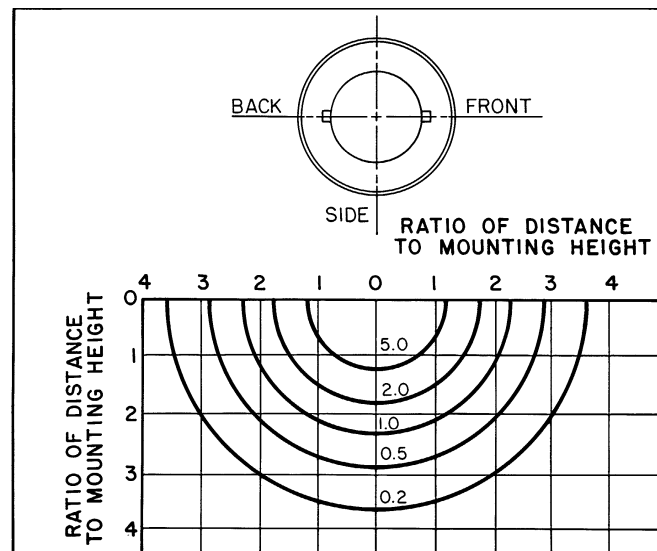

Isofootcandle Chart: Luminaire with Globe and 30° Angle Reflector

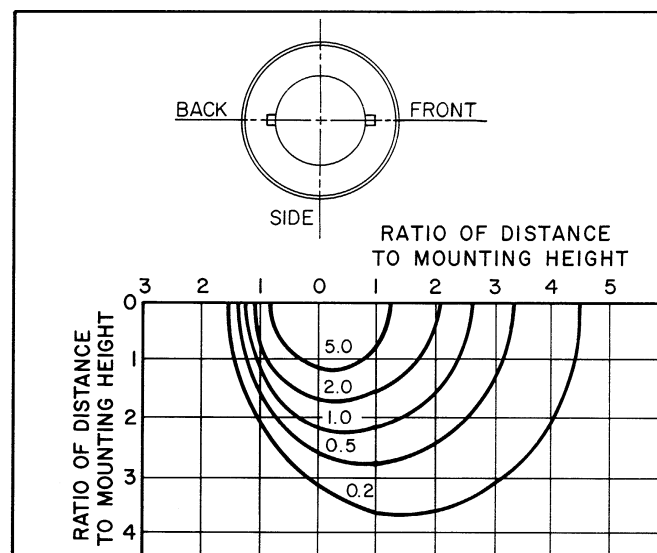

Isofootcandle charts show illumination in footcandles on work plane 10 feet below light center. Multiply by factor shown to convert to other mounting heights.

Height (Ft.)	Factor	Height (Ft.)	Factor
6	2.78	14	0.51
8	1.56	16	0.39
12	0.70		

3L

Champ® H.I.D. Luminaires

Lamp: 100W/E0 – 23½ high pressure sodium (HPS)

Luminaire with I.E.S. Type V Glass Refractor

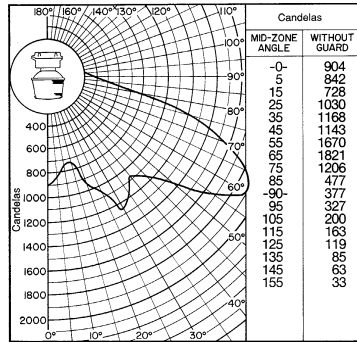

NOTE: Photometric data was developed using a 100 watt clear high pressure sodium lamp (9500 lumens). For other clear lamps, use the following conversion factors (multipliers):

Luminaire Series	Lamp Watts	Conversion Factor
	50	0.42
VMVS	70	0.67
	150	1.68

Luminaire spacing ratio: 2.0

Coefficient of Utilization

Effective Floor Cavity Reflectance 20%

% Reflectance Eff. Ceil.	Room Cavity Ratio	Wall	Room Cavity Ratio				
			1	2	3	4	5
80	50	.50	.848	.709	.597	.508	.437
	30	.30	.796	.631	.509	.414	.343
	10	.10	.750	.566	.439	.341	.271
70	50	.50	.818	.682	.576	.489	.419
	30	.30	.770	.611	.493	.402	.331
	10	.10	.726	.552	.428	.334	.264
50	50	.50	.759	.632	.533	.451	.389
	30	.30	.720	.574	.464	.377	.312
	10	.10	.685	.521	.407	.318	.253
30	50	.50	.706	.586	.493	.417	.359
	30	.30	.675	.538	.435	.354	.291
	10	.10	.645	.495	.386	.302	.240
10	50	.50	.658	.544	.457	.385	.331
	30	.30	.632	.504	.408	.331	.274
	10	.10	.608	.469	.366	.286	.227
0	0	.00	.581	.441	.340	.260	.203
% Reflectance Eff. Ceil.	Room Cavity Ratio	Wall	Room Cavity Ratio				
			6	7	8	9	10
80	50	.50	.384	.337	.299	.272	.238
	30	.30	.292	.249	.214	.189	.159
	10	.10	.226	.189	.154	.132	.103
70	50	.50	.369	.325	.288	.262	.229
	30	.30	.283	.240	.203	.183	.156
	10	.10	.218	.182	.150	.130	.105
50	50	.50	.341	.301	.266	.243	.214
	30	.30	.266	.225	.195	.173	.146
	10	.10	.209	.173	.143	.124	.099
30	50	.50	.316	.277	.248	.225	.198
	30	.30	.249	.213	.182	.161	.136
	10	.10	.199	.163	.136	.117	.093
10	50	.50	.292	.258	.223	.209	.134
	30	.30	.233	.200	.171	.151	.127
	10	.10	.188	.154	.128	.110	.087
0	0	.00	.165	.133	.108	.091	.070



3L **LMV Series 50-150W** **Low Profile -** **Medium Base** **Champ® H.I.D. Luminaires**

Cl. I, Div. 2, Groups A, B, C, D
Restricted Breathing Cl. I,
Div. 2 & Zone 2 (Suffix S826)
Certified for IEC Zone 2
(Suffix S826TB)

Cl. II, Groups E, F, G; Cl. III
& Simultaneous Presence
(HPS 35W, 50W)
Marine & Wet Locations
3, 3R, 4, 4X; IP66

Applications:

LMV series *Champ*® luminaires are used:

- In applications involving low luminaire mounting heights or restricted mounting space or where luminaire weight is a factor
- In areas in which ignitable concentrations of flammable gases or vapors will be present only due to abnormal, unusual, or accidental conditions
- Where combustible dusts are present
- Where combustible dusts and flammable vapors are present simultaneously
- In elevated ambient temperatures often found in industrial applications
- In marine applications where water spray and corrosive atmospheres are considerations
- Wherever the damaging effects of wind, snow, sleet, or hot sun are found
- In manufacturing plants, chemical, petrochemical, and other industrial process facilities, waste or sewage treatment facilities, offshore or dockside installations, cold storage facilities, parking garages or wherever dust, dirt, water, vibration and rough usage are a problem

Features:

- Compact, lightweight design is ideal for low mounting heights.
- Cast copper-free aluminum construction (less than 0.4 of 1% copper) and epoxy powder finish provide excellent resistance to corrosion.
- Seven mounting arrangements to suit any lighting layout – pendant, flexible pendant, ceiling, wall, straight stanchion, angle stanchion, and quad-mount.
- Wide range of lamp wattages to meet specifiers' needs: 50, 70, 100 and 150 watt (HPS); 70 and 100 watt (MH) medium base lamps.
- Hinged ballast housing for ease of installation and maintenance.
- All luminaires designed to perform in a 40°C ambient temperature. Selected luminaires are suitable for ambient temperatures up to 65°C.
- Superior gasketing seals between the mounting module, housing, and optical assembly for optimum performance in wet and corrosive environments.
- Hubs with an integral conduit stop and bushing to help prevent damage to field wiring during installation.
- Low ambient capability to -40°C.
- Dome and 30° angle reflectors made of bright white *Krydon*® material provide superior reflectivity, with twist-on feature requiring no tools or additional hardware. Will not chip, peel, dent, rust, or corrode.
- Grounding wire for safety.
- Medium base lamp sockets.



Certifications and Compliances:

- NEC/CEC:
 - Class I, Division 2, Groups A, B, C, D
 - HPS 35W, 50W – Class II, Class III & Simultaneous Presence (Class I, Division 2 and Class II)
 - Class I, Zone 2
- IEC:
 - Zone 2 Ex nR IIC
- UL Standards:
 - 844 Hazardous (Classified) Locations
 - 1598 Luminaires
 - 1598A Marine Locations
- CSA Standards:
 - C22.2 No. 137
- IEC Standards:
 - 60079-15

Standard Materials:

- Ballast housings and mountings – copper-free aluminum (less than 0.4 of 1%)
- Exterior hardware – stainless steel
- Reflectors (dome and angle) – *Krydon* fiberglass-reinforced polyester material
- Globes – heat and impact resistant, internally fluted glass
- Guards – copper-free aluminum

Standard Finishes:

- Copper-free aluminum – epoxy powder coat
- *Krydon* material – high reflectance white
- Stainless steel – natural

Electrical Ratings:

- 120 volts, dual-tap (120/277), multi-tap*
- 50, 70, 100, 150 watts HPS**
- 70 and 100 watts MH

* When ordering fuses for luminaires, option S658, you must specify the operating voltage. S658 cannot be ordered with /MT in the catalog number.

** 150W HPS is not available with multi tap ballast. 120V only.

Options:

The following special options are available from the factory by adding suffix to luminaire Cat. No.:

Description	Suffix
• Restricted Breathing Construction	S826
Class I, Division 2 & Zone 2 Suitability Cooler Operating Temperatures (T-Numbers)	
• Certified for IEC Zone 2.....	S826TB
Furnished with terminal block, crimp terminals and dedicated voltage ballasts (no MT, DT, or TT)	
• Fused – to protect ballast and capacitors against abnormal line conditions	S658*
(Not for use in Canada) (Not suitable for marine applications)	
• Quick-Clip - Holds weight of housing when closed. No need to support luminaire while screwing the housing to the cover	S890
• Ballast-Gard™ starter cut-out switch – prevents starter pulsing when lamp is cycling or inoperative; prolongs ballast and ignitor life. Available for use with 50–100W HPS only	BG
• Factory assembled with H.I.D. lamps installed for additional labor savings	FA
• Stainless steel insert – top hat with stainless steel threaded insert to attach ballast housing	S806

Accessories:

- See pages 1022–1023 for complete listing

LMV Series 50–150W High Pressure Sodium







Low Profile - Medium Base
Champ® H.I.D. Luminaires

Cl. I, Div. 2, Groups A, B, C, D
Restricted Breathing Cl. I,
Div. 2 & Zone 2 (Suffix S826)
Certified for IEC Zone 2
(Suffix S826TB)

Cl. II, Groups E, F, G; Cl. III
& Simultaneous Presence
(35W, 50W)
Marine & Wet Locations
3, 3R, 4, 4X; IP66

3L

To complete the catalog #, include information in notes 1, 2 and 3 below. For guards and other optics see LMV Series - Ordering By Components page.

Mounting Style	Hub Size	Lamp Watts	BASIC CATALOG NUMBER	
			With G54 Globe and P50 Guard	
	3/4	50	LMVS2A050GP	
		70	LMVS3A050GP	
	1	70	LMVS2A070GP	
		100	LMVS3A070GP	
	3/4	100	LMVS2A100GP	
		150	LMVS3A100GP	
	3/4	50	LMVS2HA050GP	
		70	LMVS2HA070GP	
	1	100	LMVS2HA100GP	
		150	LMVS2HA150GP	
	3/4	50	LMVS2C050GP	
		70	LMVS3C050GP	
	1	70	LMVS2C070GP	
		100	LMVS3C070GP	
	3/4	100	LMVS2C100GP	
		150	LMVS3C100GP	
	3/4	50	LMVS2TW050GP	
		70	LMVS3TW050GP	
	1	70	LMVS2TW070GP	
		100	LMVS3TW070GP	
	3/4	100	LMVS2TW100GP	
		150	LMVS3TW100GP	
	3/4	50	LMVS25Q050GP	
		70	LMVS25Q070GP	
	1	100	LMVS25Q100GP	
		150	LMVS25Q150GP	
	1 1/2	50	LMVSJ050GP	
		70	LMVSJ070GP	
	1	100	LMVSJ100GP	
		150	LMVSJ150GP	
	1 1/2	50	LMVSP050GP	
		70	LMVSP070GP	
	1	100	LMVSP100GP	
		150	LMVSP150GP	

3L

1. Add voltage suffix to end of catalog number
Standard Voltage Ballasts - 60Hz

Voltage Suffix	NEC/UL				CEC/CSA (cUL)		
	Multi Tap /MT	Dual Tap /DT	120V /120	480V /480	Tri Tap /TT	Dual Tap /DT	120V /120

2. 150W HPS Luminaires: For 55V lamps - add suffix LX. 50W HPS luminaire is dual tap only. 150W HPS is not available with multi tap ballast. 120V only.

3. Options - Add the required option suffixes, see page 972, in alpha-numeric order.

Crouse-Hinds
by **EATON**

3L







LMV Series 70-100W Metal Halide

Low Profile - Medium Base
Champ® H.I.D. Luminaires

Cl. I, Div. 2, Groups A, B, C, D
Restricted Breathing Cl. I,
Div. 2 & Zone 2 (Suffix S826)
Certified for IEC Zone 2
(Suffix S826TB)

Marine & Wet Locations
3, 3R, 4, 4X; IP66

To complete the catalog #, include information in notes 1, 2 and 3 below. For guards and other optics see LMV Series - Ordering By Components page.

Mounting Style	Hub Size	Lamp Watts	BASIC CATALOG NUMBER
			With G54 Globe and P50 Guard
 Pendant Mount	3/4	70	LMVM2A070GP
	1	70	LMVM3A070GP
	3/4	100	LMVM2A100GP
	1	100	LMVM3A100GP
 Flexible Pendant Mount	3/4	70	LMVM2HA070GP
	3/4	100	LMVM2HA100GP
 Ceiling Mount Thru-Feed	3/4	70	LMVM2C070GP
	1	70	LMVM3C070GP
	3/4	100	LMVM2C100GP
	1	100	LMVM3C100GP
 Wall Mount Thru-Feed	3/4	70	LMVM2TW070GP
	1	70	LMVM3TW070GP
	3/4	100	LMVM2TW100GP
	1	100	LMVM3TW100GP
 Stanchion Mount 25° Angle	1 1/2	70	LMVMJ070GP
	1 1/2	100	LMVMJ100GP
 Stanchion Mount Straight	1 1/2	70	LMVMP070GP
	1 1/2	100	LMVMP100GP

1. Add voltage suffix to end of catalog number

Standard Voltage Ballasts - 60Hz

Voltage Suffix	NEC/UL		CEC/CSA (cUL)	
	Multi Tap /MT	120V /120	480V /480	Tri Tap /TT

2. 70W ballast not available in 480V.

3. Options - Add the required option suffixes, see page 972, in alpha-numeric order.

LMV luminaires are available in components.

A complete luminaire consists of:

- I. Champ Cover (Mounting Module)
- II. LMV Ballast Housing – Include voltage and required option(s)
- III. Globe, Guard, Reflector

I. Champ Cover (Mounting Module):

Type	Conduit	Cat. #
Pendant	3/4"	APM2
	1"	APM3
Flexible Pendant	3/4"	HPM2
Ceiling	3/4"	CM2
	1"	CM3
Wall	3/4"	TWM2
	1"	TWM3
Stanchion – 25 Degree Angle	1 1/2"	JM5
Stanchion – Straight	1 1/2"	PM5
Quad-Mount	3/4"	QM25

II. Ballast Housings:

Complete catalog number must have the **voltage suffix** (MT shown) and any **options suffixes**.

Lamp Type	Lamp Watts	Cat. #
High Pressure Sodium	50	LMVS050/120
	70	LMVS070/MT
	100	LMVS100/MT
	150	LMVS150/120 LX
Metal Halide	70	LMVM070/MT
	100	LMVM100/MT

III. Globe, Guards and Reflectors:

Type	Cat. #
Globe	G54
Globe Guard	P50
Reflector – Dome	RD636
Reflector – Angle	RA636

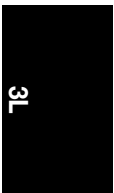

Champ® H.I.D. Luminaires

COVERS:

PENDANT

APM2 3/4 IN.

APM3 1 IN.

HPM2 3/4 IN.

WALL

TWM2 3/4 IN.

TWM3 1 IN.

QUAD—MOUNT

QM25 3/4 IN.

PHOTOCELL

V2PC20

V2PC22

V2PC27

CEILING

CM2 3/4 IN.

CM3 1 IN.

STANCHION

JM5 1 1/2 IN.

PM5 1 1/2 IN.

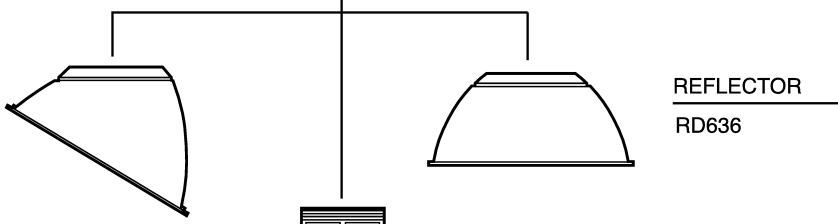
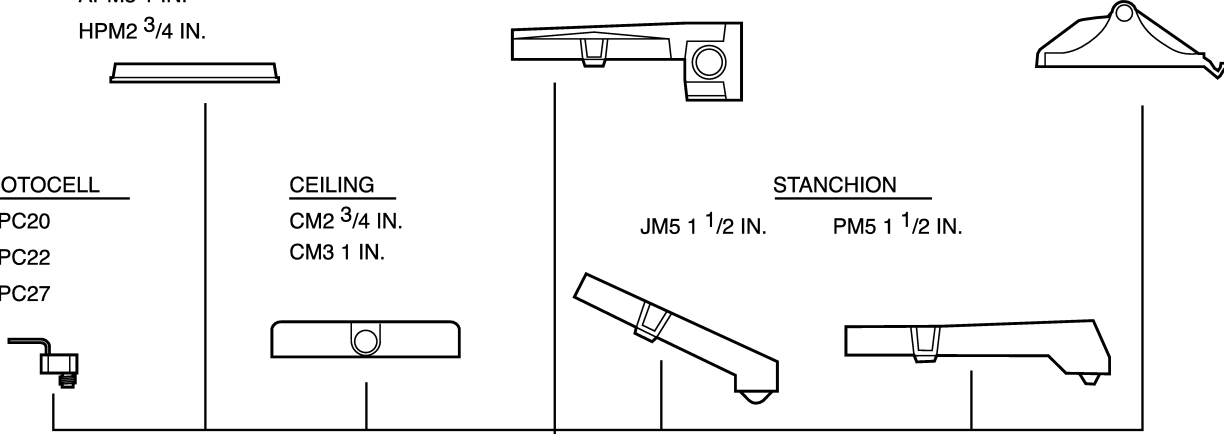

REFLECTOR
RA636

REFLECTOR
RD636

GUARD
P50

3L

Champ® H.I.D. Luminaires

Cat. #	Lamp		Rated Ambient °C	Class I, Division 2	Class II, Division 1		Simultaneous Presence Class I, Div. 2 Class II, Div. 1	Class I, Zone 2		Supply Wire Suitable for °C
	Wattage	Type		Globe (G54) w/ or w/o Reflector (RA636 or RD636)	Group	Globe (G54) w/ or w/o Reflector (RA636 or RD636)		Restricted Breathing Suffix S826 w/ Globe (G24)	Factory Sealed Suffix S865 AEx nA nR II	
LMVS50	50	HPS	40	T2D	EFG	T3C	T2B	T5	T3	N/A
LMVS50	50	HPS	55	T2C	—	—	—	T4	T3	75
LMVS50	50	HPS	65	T2C	—	—	—	T4	T3	85
LMVS70	70	HPS	40	T2B	—	—	—	T4	T3	75
LMVS70	70	HPS	55	T2B	—	—	—	T4	T3	85
LMVS100	100	HPS	40	T2	—	—	—	T4	T3	85
LMVS100	100	HPS	50	—	—	—	—	T3	T3	90
LMVM70	70	MH	40	T2B	—	—	—	T4	T3	75
LMVM70	70	MH	55	T2B	—	—	—	T4	T3	85
LMVM100	100	MH	40	—	—	—	—	T3	T3	85
LMVM150	150	HPS	40	T1 350°C	—	—	—	—	—	85

The Class I, Division 2 T-codes apply to luminaires without the restricted breathing (S826) or factory sealed (S865) options. These luminaires are listed to UL 844. UL 844 specifies how the temperatures are measured.

The Class I, Zone 2 T-codes are for luminaires that are additionally listed to UL 60079-15 that specify a different method for measuring temperatures. Since NEC® 501.1 states that equipment "...for use in Class I, Zone 0, 1, or 2 locations shall be permitted in Class I, Division 2 locations..." then these luminaires are suitable for Class I, Division 2 but with lower temperature ratings. They also have the advantage of meeting the more rigorous mechanical tests of UL 844.



Champ® H.I.D. Luminaires

Dimensions
In Inches:

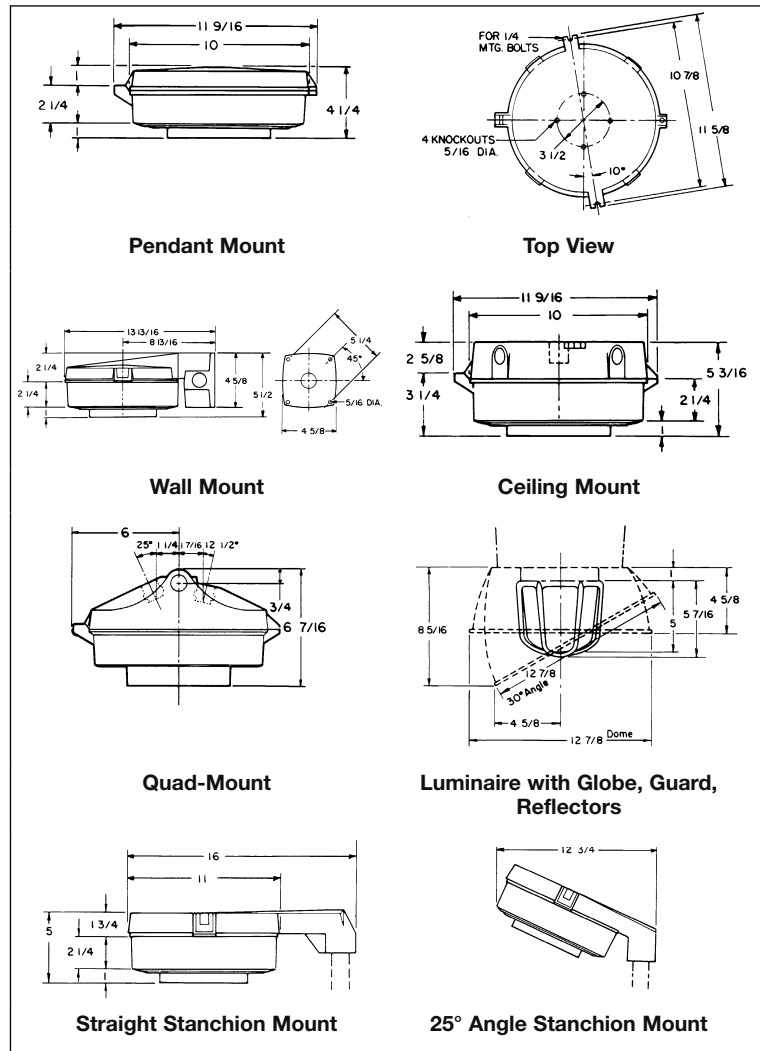

Luminaire Net Weights:

Luminaire Series	Lamp Watts	Luminaire with Globe, Guard (lbs.)
LMVS	50	7 3/4
	70	8 1/4
	100	8 3/4
	150	9 1/4
LMVM	70	9
	100	9

Type	Lbs.
Add for mounting modules:	
Pendant	1 1/4
Flexible Pendant	1 1/2
Ceiling	2 3/4
Quad-Mount	3 1/2
Wall	4 1/2
Angle Stanchion	3 1/2
Straight Stanchion	4 1/2

Type	lbs.
Add for reflectors:	
Dome	1.0
30° Angle	1.0

Deduct for luminaire without guard:	
P50 Guard	1/2

3L

Champ® H.I.D. Luminaires

Lamp: 100W/E-17 high pressure sodium (HPS)
 Total bare lamp lumens: 9500

All data provided is for high pressure sodium luminaires with 100W/E-17 clear lamps. Use conversion factors (multipliers) shown below for other lamp types and wattages. Consult Eaton's Crouse-Hinds for additional photometric data on any Champ Series.

Luminaire with Globe and Dome Reflector

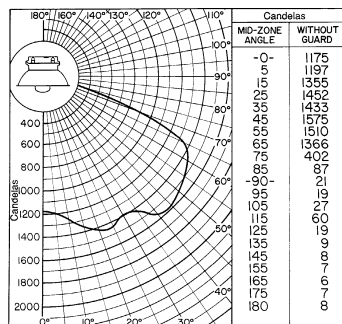

Multipliers (for use with candela curve only).

Luminaire Series	Lamp Watts	Conversion Factor
	35	0.24
	50	0.42
LMVS	70	0.67
	150	1.68

Luminaire spacing ratio: 2.0

Coefficient of Utilization

Effective Floor Cavity Reflectance 20%

% Reflectance		Room Cavity Ratio				
Eff. Ceil.	Wall	1	2	3	4	5
80	50	.722	.628	.545	.473	.413
	30	.691	.579	.487	.408	.346
	10	.663	.537	.441	.358	.296
70	50	.705	.613	.534	.463	.403
	30	.676	.568	.479	.403	.340
	10	.650	.531	.436	.355	.293
50	50	.671	.585	.511	.442	.387
	30	.647	.548	.464	.390	.332
	10	.627	.514	.426	.349	.289
30	50	.641	.560	.489	.424	.371
	30	.623	.529	.450	.379	.322
	10	.605	.501	.416	.342	.284
10	50	.614	.537	.470	.407	.356
	30	.598	.510	.436	.367	.311
	10	.584	.488	.407	.335	.279
0	0	.568	.471	.391	.319	.263

% Reflectance		Room Cavity Ratio				
Eff. Ceil	Wall	6	7	8	9	10
80	50	.366	.324	.288	.261	.226
	30	.300	.259	.225	.199	.165
	10	.253	.215	.180	.156	.127
70	50	.358	.318	.282	.256	.221
	30	.295	.255	.223	.196	.165
	10	.249	.212	.179	.156	.126
50	50	.343	.305	.271	.246	.214
	30	.288	.248	.217	.192	.161
	10	.246	.209	.177	.154	.124
30	50	.330	.292	.261	.237	.206
	30	.280	.243	.210	.186	.157
	10	.242	.205	.175	.152	.122
10	50	.317	.282	.251	.228	.199
	30	.272	.237	.206	.182	.152
	10	.238	.202	.172	.149	.120
0	0	.223	.187	.158	.136	.107

Isofootcandle Chart: Luminaire with Globe and Dome Reflector

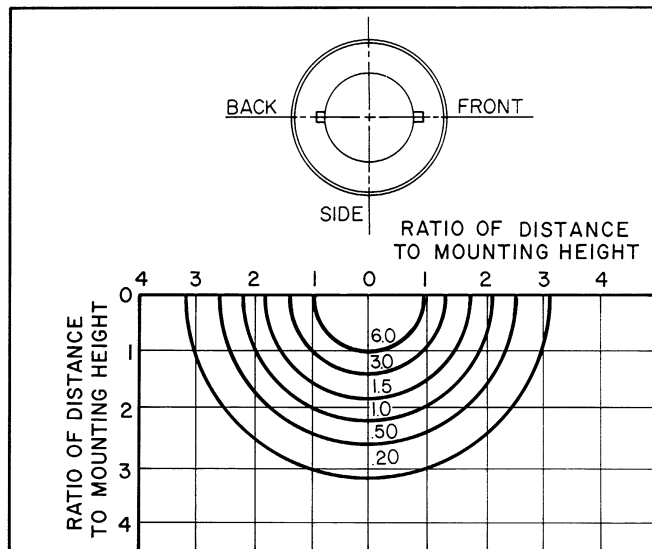

Isofootcandle Chart: Luminaire with Globe and 30° Angle Reflector

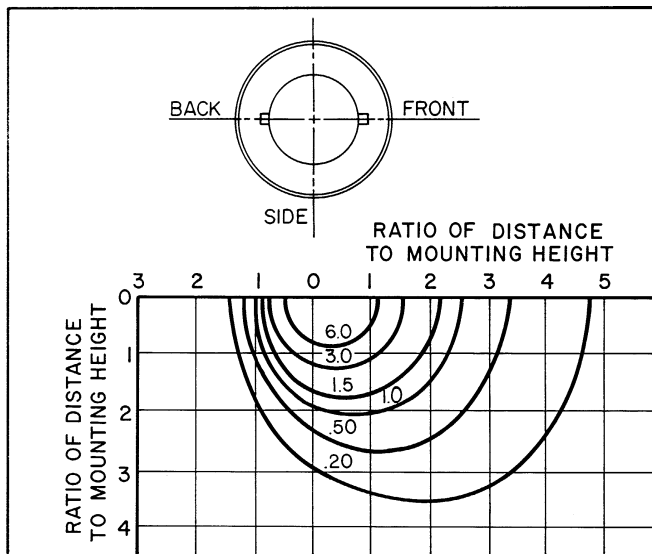

Isofootcandle charts show illumination in footcandles on work plane 10 feet below light center. Multiply by factor shown to convert to other mounting heights.

Height (Ft.)	Factor	Height (Ft.)	Factor
6	2.78	14	0.51
8	1.56	16	0.39
12	0.70		

3L DMV Series 50-250W For Combustible Dusts

Champ® H.I.D. Luminaires

Cl. I, Div. 2, Groups A, B, C, D
Restricted Breathing Cl. I, Div. 2
& Zone 2 (Suffix S826)
Certified for IEC Zone 2
(Suffix S826TB)

Cl. II, Groups E, F, G; Cl. III &
Simultaneous Presence
(175W max)
Marine & Wet Locations
3, 3R, 4, 4X; IP66

Applications:

DMV series *Champ* luminaires are used:

- In applications made hazardous by the presence of combustible dusts
- In areas in which ignitable concentrations of flammable gases or vapors will be present only due to abnormal, unusual, or accidental conditions
- In marine applications where water spray and corrosive atmospheres are considerations
- In areas where combustible dusts and flammable vapors are present simultaneously
- In elevated ambient temperatures often found in industrial applications
- In installations where moisture, dirt, dust, vibration, corrosion and rough usage are problems
- Wherever the damaging effects of wind, snow, sleet, or hot sun are found
- In grain handling, storage and processing plants, coal preparation plants, coal conveying areas, food processing plants, manufacturing plants, refineries, chemical, petrochemical, and other industrial process facilities, waste or sewage treatment facilities, offshore, dockside, and harbor installations, and other heavy industrial applications

Features:

- Cast copper-free aluminum construction (less than 0.4 of 1% copper) and epoxy powder finish provide excellent resistance to corrosion.
- Seven mounting arrangements to suit any lighting layout – pendant, flexible pendant, ceiling, wall bracket, angle stanchion, straight stanchion, and quad-mount.
- Wide range of light sources and wattages to meet specifiers' needs: 50, 70, 100, 150 watt high pressure sodium (HPS); 70, 100, 175, 250 watt metal halide.
- Hinged ballast housing for ease of installation and maintenance.
- All luminaires designed to perform in a 40°C ambient temperature. Selected luminaires are suitable for ambient temperatures up to 65°C.
- Superior gasketing seals between the mounting module, housing, and optical assembly for optimum performance in wet and corrosive environments.
- Hubs with an integral conduit stop and bushing to help prevent damage to field wiring during installation.
- Low ambient capability to (-40°C.)
- Dome and 30° angle reflectors made of bright white *Krydon*® material provide superior reflectivity, with twist-on feature requiring no tools or additional hardware. Will not chip, peel, dent, rust, or corrode.
- Mogul base porcelain lamp socket.
- Stainless steel open bottom guard permits direct access to the globe for easy relamping.



- Grounding wire for safety.
- Ballasts available in voltages of 120, 208, 240, 277, 347, 480, 600 and multi-tap.*

Certifications and Compliances:

- NEC/CEC:
 - Class I, Division 2, Groups A, B, C, D
 - 175W max – Class II, Class III & Simultaneous Presence (Class I, Division 2 and Class II)
 - Class I, Zone 2
- IEC:
 - Zone 2 Ex nR IIC
- UL Standards:
 - 844 Hazardous (Classified) Locations
 - 1598 Luminaires
 - 1598A Marine Locations
- CSA Standards:
 - C22.2 No. 137
- IEC Standards:
 - 60079-15

Standard Materials:

- Ballast housings and mountings – copper-free aluminum (less than 0.4 of 1% copper)
- Guard and exterior hardware – stainless steel
- Reflectors (dome and angle) – *Krydon* fiberglass-reinforced polyester material
- Globes – heat and impact resistant, internally fluted glass

Standard Finishes:

- Copper-free aluminum – epoxy powder coat
- *Krydon* material – high reflectance white
- Stainless steel – natural

Electrical Ratings:

- 120, multi-tap* (120, 208, 240 and 277), tri-tap (120, 277, 347) 480, 600 volts
- 50–250W HPS; 70–250W MH

Options:

The following special options are available from the factory by adding suffix to luminaire Cat. No.:

- | Description | Suffix |
|---|---------------|
| • Restricted Breathing Construction . . . | S826 |
| Class I, Division 2 & Zone 2 | |
| Suitability | |
| Cooler Operating Temperatures (T-Numbers) | |
| • Restricted Breathing/Non-Sparking . . | S865 |
| Class I, Division 2 & Zone 2 | |
| Provides T3 code without conduit or cable seals | |
| • Certified for IEC Zone 2 | S826TB |
| Furnished with terminal block, crimp terminals and dedicated voltage ballasts (no MT, DT or TT) | |
| • Fused – to protect ballast and capacitors against abnormal line conditions | S658* |
| (Not available with /MT Ballast) (Not for use in Canada) (Not suitable for marine applications) | |
| • Quick-Clip - Holds weight of housing when closed. No need to support luminaire while screwing the housing to the cover | S890 |
| • Ballast-Gard™ starter cut-out switch – prevents starter pulsing when lamp is cycling or inoperative; prolongs ballast and ignitor life. Available for use with 50–150W LX HPS only | BG |
| • Instant restrike – enables a hot HPS lamp to immediately restrike after a momentary loss of arc due to voltage fluctuation or power outage. It has no effect on the warm-up period of cold lamps. 50–150W LX HPS only | IR |
| 50–100W LX HPS only | TIR |
| • Quartz auxiliary lighting – comes to full brightness immediately and remains lit until the HID lamp attains 60–70% of full illumination. For non-hazardous locations only. (Note: QTZ lamp not included; use 100W single ended lamp – Q100DC, Q100CL/DC, or 100Q/CL/DC) Consult factory for top-hat limitations | QTZ |
| • Factory assembled with H.I.D. lamps installed for additional labor savings | FA |
| • TEFLON® coated globe for additional protection against breakage. For use with 50–150W HPS and 70–175W MH (G303 only) | S808 |

Note: Some T-numbers (operating temperatures) change. See "Temperature Performance Data" section.

- Stainless steel insert – top hat with stainless steel threaded insert to attach ballast housing **S806**

Note: BG and IR options cannot be used together. IR and QTZ options cannot be used together.

Accessories:

- See pages 1022–1023 for complete listing.

TEFLON is a registered trademark of E.I. duPont Co. *When ordering fuses for luminaires, option S658, you must specify the operating voltage. S658 cannot be ordered with /MT in the catalog number.

Crouse-Hinds
by **E.T.N**

DMV Series 50-150W High Pressure Sodium



For Combustible Dust Applications
Champ® H.I.D. Luminaires

Cl. I, Div. 2, Groups A, B, C, D
Restricted Breathing Cl. I, Div. 2
& Zone 2 (Suffix S826)
Certified for IEC Zone 2 (Suffix
S826TB)

Cl. II, Groups E, F, G; Cl. III
& Simultaneous Presence
Marine & Wet Locations
3, 3R, 4, 4X; IP66

3L

To complete the catalog #, include information in notes 1, 2 and 3 below. For guards and other optics see DMV Series - Ordering By Components page.

	Mounting Style	Hub Size	Lamp Watts	BASIC CATALOG NUMBER		
				With G303 Globe and P33 Guard	With GR305 Glass Refractor *	
	Pendant Mount	3/4	50	DMVS2A050GP	DMVS2A050GR305	
		1		DMVS3A050GP	DMVS3A050GR305	
		3/4	70	DMVS2A070GP	DMVS2A070GR305	
		1		DMVS3A070GP	DMVS3A070GR305	
		3/4	100	DMVS2A100GP	DMVS2A100GR305	
		1		DMVS3A100GP	DMVS3A100GR305	
	Flexible Pendant Mount	3/4	50	DMVS2HA050GP	DMVS2HA050GR305	
		3/4	70	DMVS2HA070GP	DMVS2HA070GR305	
		3/4	100	DMVS2HA100GP	DMVS2HA100GR305	
		3/4	150	DMVS2HA150GP	DMVS2HA150GR305	
	Ceiling Mount Thru-Feed	3/4	50	DMVS2C050GP	DMVS2C050GR305	
		1		DMVS3C050GP	DMVS3C050GR305	
		3/4	70	DMVS2C070GP	DMVS2C070GR305	
		1		DMVS3C070GP	DMVS3C070GR305	
		3/4	100	DMVS2C100GP	DMVS2C100GR305	
		1		DMVS3C100GP	DMVS3C100GR305	
	Wall Mount Thru-Feed	3/4	50	DMVS2TW050GP	DMVS2TW050GR305	
		1		DMVS3TW050GP	DMVS3TW050GR305	
		3/4	70	DMVS2TW070GP	DMVS2TW070GR305	
		1		DMVS3TW070GP	DMVS3TW070GR305	
		3/4	100	DMVS2TW100GP	DMVS2TW100GR305	
		1		DMVS3TW100GP	DMVS3TW100GR305	
	Quad-Mount Pendant, Adjustable Thru-Feed, 25° Angle, 12 1/2° Angle	3/4	50	DMVS25Q050GP	DMVS25Q050GR305	
		3/4	70	DMVS25Q070GP	DMVS25Q070GR305	
		3/4	100	DMVS25Q100GP	DMVS25Q100GR305	
		3/4	150	DMVS25Q150GP	DMVS25Q150GR305	
	Stanchion Mount 25° Angle	1 1/2	50	DMVSJ050GP	DMVSJ050GR305	
		1 1/2	70	DMVSJ070GP	DMVSJ070GR305	
		1 1/2	100	DMVSJ100GP	DMVSJ100GR305	
		1 1/2	150	DMVSJ150GP	DMVSJ150GR305	
	Stanchion Mount Straight	1 1/2	50	DMVSP050GP	DMVSP050GR305	
		1 1/2	70	DMVSP070GP	DMVSP070GR305	
		1 1/2	100	DMVSP100GP	DMVSP100GR305	
		1 1/2	150	DMVSP150GP	DMVSP150GR305	

* For GR302 Type II Refractor, change "GR305" at end of catalog number to "GR302". Ex. DMVS2A050GR302
For GR303 Type III Refractor, change "GR305" at end of catalog number to "GR303". Ex. DMVS2A050GR303

1. Add voltage suffix to end of catalog number
Standard Voltage Ballasts - 60Hz

Voltage Suffix	NEC/UL				CEC/CSA (cUL)		
	Multi Tap /MT	Dual Tap /DT	120V /120	480V /480	Tri Tap /TT	Dual Tap /DT	120V /120

Optional Voltage Ballasts - 50 or 60Hz

Voltage Suffix	CEC/CSA (cUL) - CWI Isolated Ballasts				EXPORT			
	208V CWI /208CWI	240V CWI /240CWI	480V CWI /480CWI	600V CWI /600CWI	220V 60Hz /220	220V 50Hz /220 50	230V 50Hz /230 50	240V 50Hz /240 50

2. 150W HPS Luminaires: For 55V lamps - add suffix LX; for 100V lamps - add suffix CE. 50W HPS luminaire is dual tap only.

3. Options - Add the required option suffixes, see page 980, in alpha-numeric order.

Crouse-Hinds
by **E.T.N.**

3L





3L DMV Series - 150-250W Pulse Start Metal Halide

For Combustible Dust Applications
Champ® H.I.D. Luminaires

Cl. I, Div. 2, Groups A, B, C, D
Restricted Breathing Cl. I, Div. 2
& Zone 2 (Suffix S826)
Certified for IEC Zone 2
(Suffix S826TB)

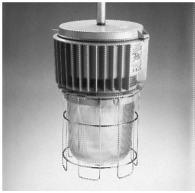
Cl. II, Groups E, F, G; Cl. III &
Simultaneous Presence
(175W max)
Marine & Wet Locations
3, 3R, 4, 4X; IP66

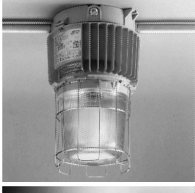
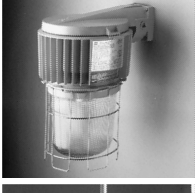
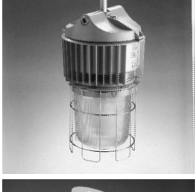
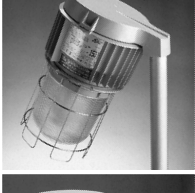
To complete the catalog #, include information in notes 1 and 2 below. For guards and other optics see DMV Series - Ordering By Components page.

Mounting Style	Hub Size	Lamp Watts	BASIC CATALOG NUMBER	
			With G303 Globe and P33 Guard	With GR305 Glass Refractor *
	3/4	150	DMVM2A150GP S828	DMVM2A150GR305 S828
		1	DMVM3A150GP S828	DMVM3A150GR305 S828
	3/4	175	DMVM2A175GP S828	DMVM2A175GR305 S828
		1	DMVM3A175GP S828	DMVM3A175GR305 S828
	3/4	200	DMVM2A200GP S828	DMVM2A200GR305 S828
		1	DMVM3A200GP S828	DMVM3A200GR305 S828
		1	DMVM3A250GP S828	DMVM3A250GR305 S828
	3/4	150	DMVM2HA150GP S828	DMVM2HA150GR305 S828
	3/4	175	DMVM2HA175GP S828	DMVM2HA175GR305 S828
	3/4	200	DMVM2HA200GP S828	DMVM2HA200GR305 S828
	3/4	250	DMVM2HA250GP S828	DMVM2HA250GR305 S828
	3/4	150	DMVM2C150GP S828	DMVM2C150GR305 S828
		1	DMVM3C150GP S828	DMVM3C150GR305 S828
	3/4	175	DMVM2C175GP S828	DMVM2C175GR305 S828
		1	DMVM3C175GP S828	DMVM3C175GR305 S828
	3/4	200	DMVM2C200GP S828	DMVM2C200GR305 S828
		1	DMVM3C200GP S828	DMVM3C200GR305 S828
		1	DMVM3C250GP S828	DMVM3C250GR305 S828
	3/4	150	DMVM2TW150GP S828	DMVM2TW150GR305 S828
		1	DMVM3TW150GP S828	DMVM3TW150GR305 S828
	3/4	175	DMVM2TW175GP S828	DMVM2TW175GR305 S828
		1	DMVM3TW175GP S828	DMVM3TW175GR305 S828
	3/4	200	DMVM2TW200GP S828	DMVM2TW200GR305 S828
		1	DMVM3TW200GP S828	DMVM3TW200GR305 S828
		1	DMVM3TW250GP S828	DMVM3TW250GR305 S828
	3/4	150	DMVM25Q150GP S828	DMVM25Q150GR305 S828
	3/4	175	DMVM25Q175GP S828	DMVM25Q175GR305 S828
	3/4	200	DMVM25Q200GP S828	DMVM25Q200GR305 S828
	3/4	250	DMVM25Q250GP S828	DMVM25Q250GR305 S828
	1 1/2	150	DMVMJ150GP S828	DMVMJ150GR305 S828
		175	DMVMJ175GP S828	DMVMJ175GR305 S828
	1 1/2	200	DMVMJ200GP S828	DMVMJ200GR305 S828
		250	DMVMJ250GP S828	DMVMJ250GR305 S828
	1 1/2	150	DMVMP150GP S828	DMVMP150GR305 S828
		175	DMVMP175GP S828	DMVMP175GR305 S828
	1 1/2	200	DMVMP200GP S828	DMVMP200GR305 S828
		250	DMVMP250GP S828	DMVMP250GR305 S828

* For GR302 Type II Refractor, change "GR305" at end of catalog number to "GR302". Ex. DMVM2A150GR302-S828
For GR303 Type III Refractor, change "GR305" at end of catalog number to "GR303". Ex. DMVM2A150GR303-S828

1. Add voltage suffix to end of catalog number
Standard Voltage Ballasts - 60Hz

Voltage Suffix	Multi Tap /MT	NEC/UL		CEC/CSA (cUL)	
		120V /120	480V /480	Tri Tap /TT	120V /120

Optional Voltage Ballasts - 50 or 60Hz

Voltage Suffix	EXPORT			
	220V 60Hz /220	220V 50Hz /220 50	230V 50Hz /230 50	240V 50Hz /240 50

2. Options - Add the required option suffixes, see page 980, in alpha-numeric order.

DMV Series 70-250W Metal Halide

For Combustible Dust Applications
Champ® H.I.D. Luminaires

Cl. I, Div. 2, Groups A, B, C, D
Restricted Breathing Cl. I, Div. 2
& Zone 2 (Suffix S826)
Certified for IEC Zone 2
(Suffix S826TB)

Cl. II, Groups E, F, G; Cl. III &
Simultaneous Presence
(175W max)
Marine & Wet Locations
3, 3R, 4, 4X; IP66

3L

To complete the catalog #, include information in notes 1, 2 and 3 below. For guards and other optics see DMV Series - Ordering By Components page.

Mounting Style	Hub Size	Lamp Watts	BASIC CATALOG NUMBER		
			With G303 Globe and P33 Guard	With GR305 Glass Refractor *	
	3/4	70	DMVM2A070GP	DMVM2A070GR305	
		1	DMVM3A070GP	DMVM3A070GR305	
	1	100	DMVM2A100GP	DMVM2A100GR305	
		1	DMVM3A100GP	DMVM3A100GR305	
	3/4	175	DMVM2A175GP	DMVM2A175GR305	
		1	DMVM3A175GP	DMVM3A175GR305	
	3/4	70	DMVM2HA070GP	DMVM2HA070GR305	
		100	DMVM2HA100GP	DMVM2HA100GR305	
	3/4	175	DMVM2HA175GP	DMVM2HA175GR305	
		250	DMVM2HA250GP	DMVM2HA250GR305	
		3/4	70	DMVM2C070GP	DMVM2C070GR305
			1	DMVM3C070GP	DMVM3C070GR305
1		100	DMVM2C100GP	DMVM2C100GR305	
		1	DMVM3C100GP	DMVM3C100GR305	
3/4		175	DMVM2C175GP	DMVM2C175GR305	
		1	DMVM3C175GP	DMVM3C175GR305	
	3/4	70	DMVM2TW070GP	DMVM2TW070GR305	
		1	DMVM3TW070GP	DMVM3TW070GR305	
	1	100	DMVM2TW100GP	DMVM2TW100GR305	
		1	DMVM3TW100GP	DMVM3TW100GR305	
	3/4	175	DMVM2TW175GP	DMVM2TW175GR305	
		1	DMVM3TW175GP	DMVM3TW175GR305	
	3/4	70	DMVM25Q070GP	DMVM25Q070GR305	
		100	DMVM25Q100GP	DMVM25Q100GR305	
	3/4	175	DMVM25Q175GP	DMVM25Q175GR305	
		250	DMVM25Q250GP	DMVM25Q250GR305	
		1 1/2	70	DMVMJ070GP	DMVMJ070GR305
		1 1/2	100	DMVMJ100GP	DMVMJ100GR305
1 1/2		175	DMVMJ175GP	DMVMJ175GR305	
1 1/2		250	DMVMJ250GP	DMVMJ250GR305	
	1 1/2	70	DMVMP070GP	DMVMP070GR305	
	1 1/2	100	DMVMP100GP	DMVMP100GR305	
	1 1/2	175	DMVMP175GP	DMVMP175GR305	
	1 1/2	250	DMVMP250GP	DMVMP250GR305	

* For GR302 Type II Refractor, change "GR305" at end of catalog number to "GR302". Ex. DMVM2A070GR302
For GR303 Type III Refractor, change "GR305" at end of catalog number to "GR303". Ex. DMVM2A070GR303

1. Add voltage suffix to end of catalog number
Standard Voltage Ballasts - 60Hz

Voltage Suffix	Multi Tap /MT	NEC/UL		CEC/CSA (cUL)	
		120V /120	480V /480	Tri Tap /TT	120V /120

Optional Voltage Ballasts - 50 or 60Hz

Voltage Suffix	CEC/CSA (cUL) - CWI Isolated Ballasts - 175W and 250W MH only				EXPORT			
	208V CWI /208CWI	240V CWI /240CWI	600V CWI /600CWI		220V 60Hz /220	220V 50Hz /220 50	230V 50Hz /230 50	240V 50Hz /240 50

2. 70W ballast not available in 480V.

3. Options - Add the required option suffixes, see page 980, in alpha-numeric order.

Crouse-Hinds
by **EATON**

3L

3L DMV Series – Ordering by Components

DMV luminaires are available in components.

A complete luminaire consists of:

- I. Champ Cover (Mounting Module)
- II. DMV Ballast Housing – Include voltage and required option(s)
- III. Globe, Refractor, Guard, Reflector

I. Champ Cover (Mounting Module):

Type	Conduit	Cat. #
Pendant	3/4"	APM2
	1"	APM3
Flexible Pendant	3/4"	HPM2
Ceiling	3/4"	CM2
	1"	CM3
Wall	3/4"	TWM2
	1"	TWM3
Stanchion – 25 Degree Angle	1 1/2"	JM5
Stanchion – Straight	1 1/2"	PM5
Quad-Mount	3/4"	QM25

II. Ballast Housings:

Complete catalog number must have the **voltage suffix** (MT shown) and any **options suffixes**.

Lamp Type	Lamp Watts	Cat. #
High Pressure Sodium	50	DMVS050/MT
	70	DMVS070/MT
	100	DMVS100/MT
	150	DMVS150/MT LX
Metal Halide	70	DMVM070/MT
	100	DMVM100/MT
	175	DMVM175/MT
	250	DMVM250/MT

III. Globe, Reflectors, Refractors, Guards:

Type	Cat. #
Globe	G303
Globe – Teflon Coated	G303S808
Globe Guard	P33
Reflector – Dome	RD739
Reflector – Angle	RA739
Refractor – Type 2	GR302
Refractor – Type 3	GR303
Refractor – Type 5	GR305
Large Plastic Refractor Type 2	PGR302
Large Plastic Refractor Type 3	PGR303
Large Plastic Refractor Type 5	PGR305
Refractor Guard	P23
High Bay Reflector/Lens	GRD4

3L

Champ® H.I.D. Luminaires

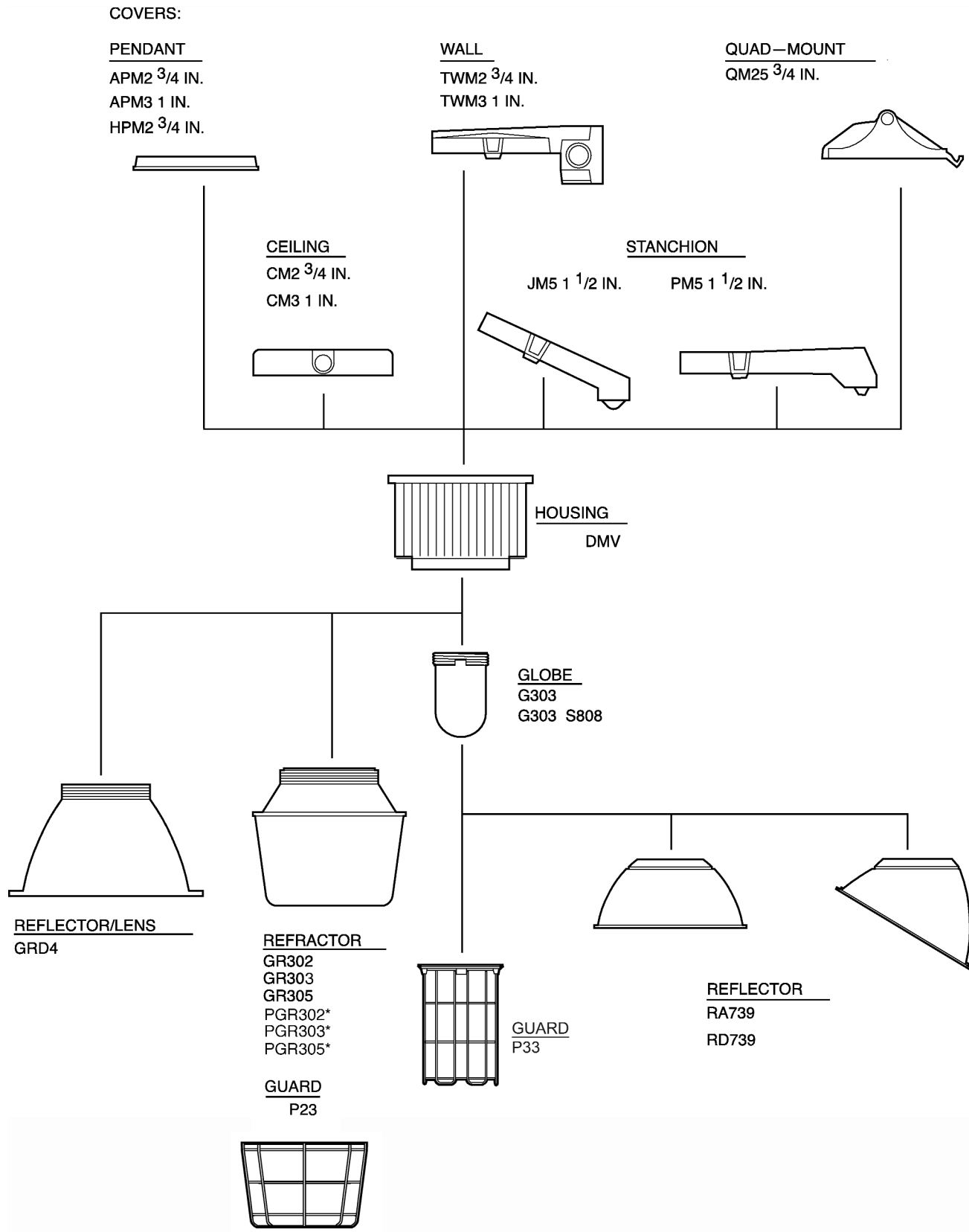

*Plastic refractors are non-hazardous areas only (50-100W Max.)

Champ® H.I.D. Luminaires

Cat. #	Lamp		Rated Ambient °C	Class I, Division 2		Class II, Division 1		Simultaneous Presence Class I, Div. 2 Class II, Div. 1 (with G303 Globe only)	Class I, Zone 2			Supply Wire Suitable for °C
	Wattage	Type		Globe (G303) w/ or w/o Reflector (RA739 or RD739)*	Reflector (GR302 or GR305)	Refractor (G302 or G303) or Globe (G303)†	Globe (G303) with Reflector (RA739 or RD739)		Restricted Breathing Suffix S826 w/ Globe (G303)	Globe (G303) with Reflector (RA739 or RD739)	Factory Sealed Suffix S865 AEx nA nR II	
DMVS50	50	HPS	40	T3A	T3A	T6	T6	T3A	T6	T6	T3	90
DMVS50	50	HPS	55	T3	T3	T5	T5	T3	T5	T5	T3	90
DMVS50	50	HPS	65	T3	T3	T4A	T4A	T3	T5	T5	T3	90
DMVS70	70	HPS	40	T3A	T3A	T6	T6	T3A	T6	T6	T3	90
DMVS70	70	HPS	55	T3	T3	T5	T5	T3	T5	T5	T3	90
DMVS70	70	HPS	65	T3	T3	T4A	T4A	T3	T5	T5	T3	90
DMVS100	100	HPS	40	T2D	T2D	T5	T5	T3D	T6	T6	T3	90
DMVS100	100	HPS	55	T2C	T2C	T4A	T4A	T2C	T5	T5	T3	90
DMVS100	100	HPS	65	T2C	T2C	—	—	—	T4	T4	T3	90
DMVS150	150	HPS	40	T2B	T2B	T3C	T3C	T2A	T5	T5	T3	90
DMVS150	150	HPS	55	T2B	T2B	—	—	—	T4	T4	T3	90
DMVS150	150	HPS	65	T2A	T2B	—	—	—	—	—	T3	90
DMVM70	70	MH	40	T3C*	T3C	T3C	—	—	T6	T6	T3	90
DMVM70	70	MH	55	T3B*	T3C	—	—	—	T5	T5	T3	90
DMVM70	70	MH	65	T3A*	T3A	—	—	—	T5	T5	T3	90
DMVM100	100	MH	40	T3*	T3A	T3C	—	—	T5	T5	T3	90
DMVM100	100	MH	55	T3*	T3A	—	—	—	T5	T5	T3	90
DMVM100	100	MH	65	T2D*	T2D	—	—	—	T4	T4	T3	90
DMVM150	150	MH PS	40	T2B	—	T4A	T4A	—	T4	T4	T3	105
DMVM150	150	MH PS	55	T2A	—	T4	T4	—	T4	T4	T3	105
DMVM150	150	MH PS	65	T2A	—	T4	T4	—	T4	T4	T3	105
DMVM175	175	MH	40	T2B*	T2	T3C	T3C	T2A	T4	T4	T3	90
DMVM175	175	MH	55	T2A*	T2	—	—	—	T4	T4	T3	90
DMVM175	175	MH	65	T2A*	T2	—	—	—	T3	T3	T3	90
DMVM175	175	MH PS	40	T2B*	—	T4A	T4A	—	T4	T4	T3	105
DMVM175	175	MH PS	55	T2A*	—	T4	T4	—	T4	T4	T3	105
DMVM175	175	MH PS	65	T2A*	—	T4	T4	—	T4	T4	T3	105
DMVM200	200	MH	40	T2	—	—	—	—	T4	T4	T3	90
DMVM200	200	MH	55	T1 (325)	—	—	—	—	T3	T3	T3	90
DMVM250	250	MH	40	T2	—	—	—	—	T4	T4	T3	90
DMVM250	250	MH	55	T1 (325)	—	—	—	—	T3	T3	T3	90
DMVF52	2 / 26 (52)	CF	40	T3	—	T6	—	—	T6	T6	T3	90
DMVF64	2 / 32 (64)	CF	40	T3	—	T6	T6	—	T6	T6	T3	90
DMVF84	2 / 42 (84)	CF	40	T3A	—	T4A	T4A	—	T4	T4	—	90
DMVIG85	85	Induction	40	T3	T3	T5	T5	—	T6	T6	T5	90
DMVIG85	85	Induction	55	T2D	T2D	T4A	T4A	—	T5	T5	T4	90
DMVIG165	165	Induction	40	T3	—	T2D	—	T2D	T5	—	—	90

The Class I, Division 2 T-codes apply to luminaires without the restricted breathing (S826) or factory sealed (S865) options. These luminaires are listed to UL 844. UL 844 specifies how the temperatures are measured.

The Class I, Zone 2 T-codes are for luminaires that are additionally listed to UL 60079-15 that specify a different method for measuring temperatures. Since NEC® 501.1 states that equipment "...for use in Class I, Zone 0, 1, or 2 locations shall be permitted in Class I, Division 2 locations..." then these luminaires are suitable for Class I, Division 2 but with lower temperature ratings. They also have the advantage of meeting the more rigorous mechanical tests of UL 844.

*All DMVM 175W and below MH luminaires provided with Catalog number G303-S808 have a T2A T-code.

†For use with refractor only when this table indicates by means of a T-code that the refractor is suitable for use with Class I, Division 2 luminaires.

3L

Champ® H.I.D. Luminaires

**Dimensions
In Inches:**

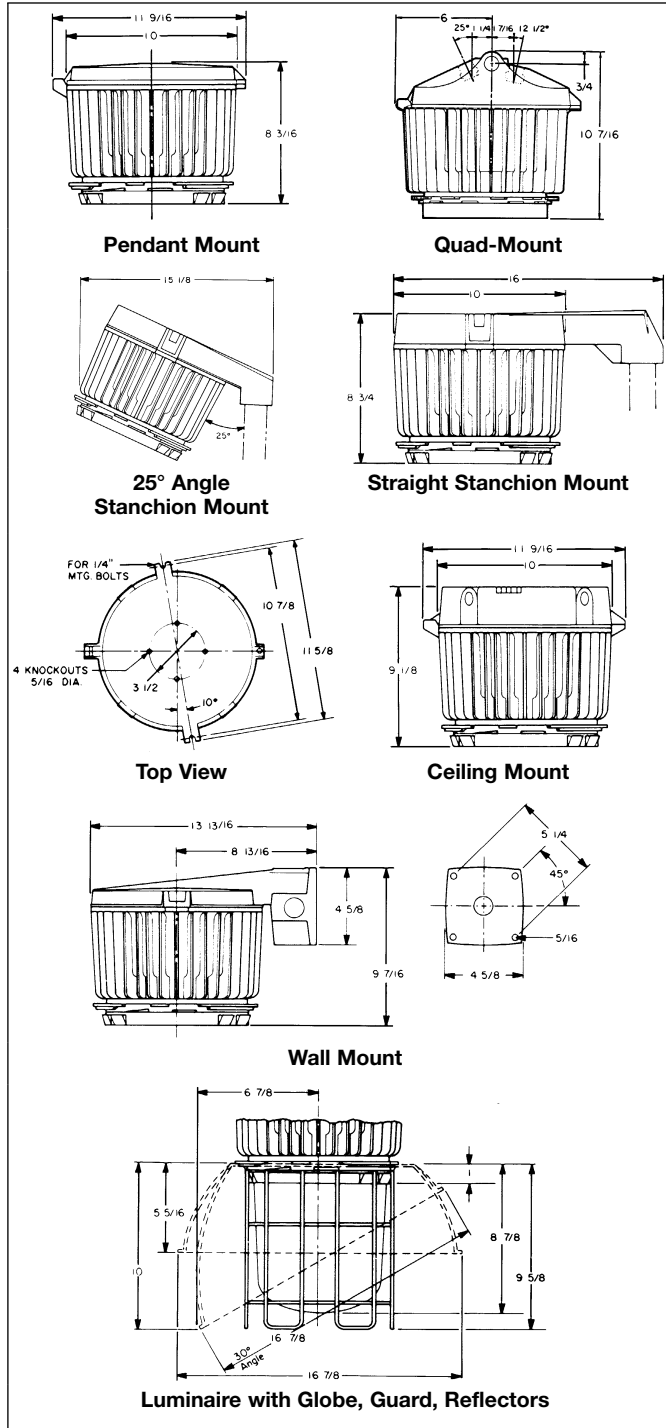

Net Luminaire Weights (lbs.):

Luminaire Series	Lamp Watts	Luminaire with Globe, Guard (lbs.)	Lamp Watts	Luminaire with Globe, Guard (lbs.)
DMVS	50	23	70	23 3/16
	100	24 1/16	150	26 7/8
DMVM	70	21	100	21 1/16
	175	22 1/4	250	24

Type	Lbs.	Type	Lbs.
Add for mounting modules:			
Pendant	1 1/4	Flexible Pendant	1 1/2
Ceiling	2 3/4	Wall	4 1/2
Quad Mount	3 1/2	Angle Stanchion	3 1/2
Straight Stanchion	4 1/2		

Add for reflectors:			
Dome	1 1/4	30° Angle	1 3/4
Deduct: 1 lb. for luminaire without P33 Guard.			
Add: 5 1/2 lbs. for luminaire with GR305 refractor.			



Champ® H.I.D. Luminaires

Lamp: 150W/E-23-1/2 clear high pressure sodium (HPS)
Total bare lamp lumens: 16000

NOTE: All data provided is for high pressure sodium luminaires with 150W/E-23-1/2 clear lamps. Use conversion factors (multipliers) shown below for other clear lamp types and wattages. Consult Eaton's Crouse-Hinds for additional photometric data on any Champ series luminaires.

Luminaire with Globe and Dome Reflector

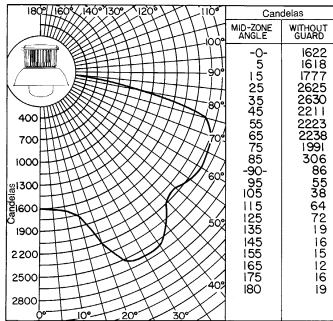

Multipliers (for use with candela curve only).

Luminaire Series	Lamp Watts	Conversion Factor
DMVS	50	0.25
	70	0.40
	100	0.59

Luminaire spacing ratio: 1.90

Coefficient of Utilization

Effective Floor Cavity Reflectance 20%

% Reflectance Eff. Ceil.	Wall	Room Cavity Ratio				
		1	2	3	4	5
80	50	.759	.643	.551	.476	.418
	30	.719	.582	.480	.400	.340
	10	.683	.530	.424	.342	.283
70	50	.740	.627	.538	.465	.406
	30	.703	.570	.471	.394	.334
	10	.669	.523	.418	.338	.280
50	50	.703	.595	.512	.442	.388
	30	.672	.548	.455	.381	.324
	10	.645	.506	.408	.332	.276
30	50	.669	.567	.488	.422	.370
	30	.646	.528	.439	.368	.314
	10	.622	.492	.399	.325	.270
10	50	.640	.541	.466	.403	.354
	30	.619	.508	.424	.356	.305
	10	.600	.479	.389	.318	.265
0	0	.582	.459	.370	.299	.247
% Reflectance Eff. Ceil.	Wall	Room Cavity Ratio				
		6	7	8	9	10
80	50	.371	.330	.294	.267	.231
	30	.296	.257	.224	.198	.164
	10	.243	.208	.174	.151	.121
70	50	.362	.323	.288	.262	.226
	30	.291	.252	.221	.195	.164
	10	.238	.204	.173	.151	.121
50	50	.345	.309	.275	.250	.218
	30	.283	.244	.215	.190	.159
	10	.235	.201	.170	.148	.119
30	50	.331	.294	.265	.240	.209
	30	.275	.239	.208	.184	.154
	10	.231	.196	.168	.146	.116
10	50	.317	.284	.253	.231	.201
	30	.266	.233	.203	.180	.150
	10	.227	.193	.165	.143	.114
0	0	.210	.177	.149	.128	.100

Isofootcandle Chart: Luminaire with Globe and Dome Reflector

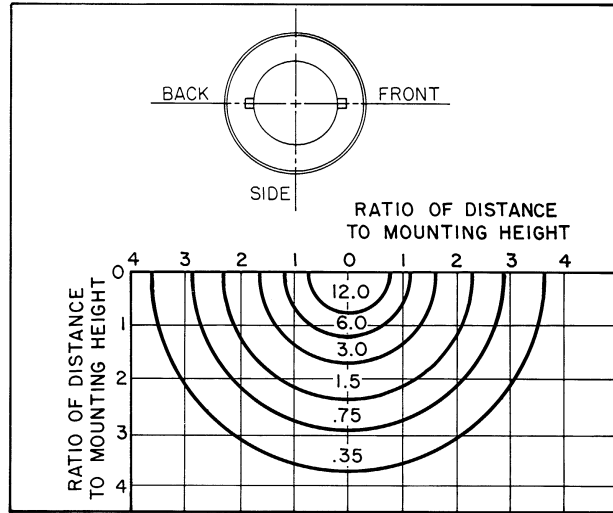

Isofootcandle Chart: Luminaire with Globe and 30° Angle Reflector

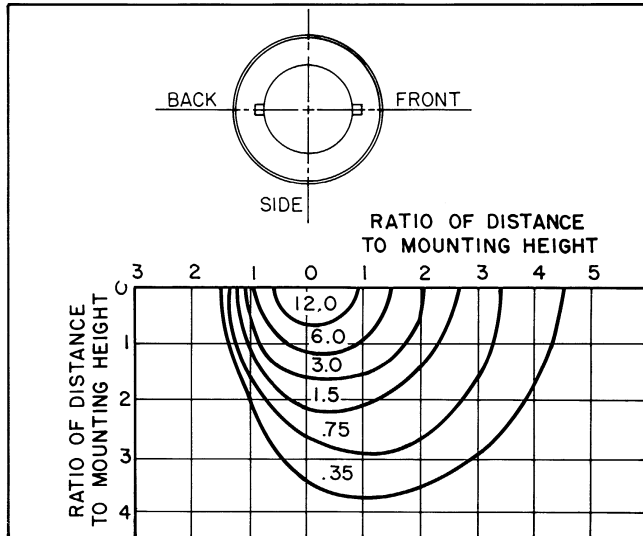

Isofootcandle charts show illumination in footcandles on work plane 10 feet below light center. Multiply by factor shown to convert to other mounting heights.

Height (Ft.)	Factor	Height (Ft.)	Factor
8	1.56	16	.391
12	.694	20	.250
14	.510		

VMV High Wattage Series 200-400W For Medium and High Mounting Heights

Cl. I, Div. 2, Groups A, B, C, D
Restricted Breathing Cl. I,
Div. 2 & Zone 2 (Suffix S826)
Certified for IEC Zone 2
(Suffix S826TB)

Cl. II, Groups E, F, G; Cl. III &
Simultaneous Presence
(with Glass Refractor)
Marine (with Globe or Glass
Refractor) & Wet Locations
3, 3R, 4, 4X; IP66

3L

Champ® H.I.D. Luminaires

Applications:

VMV high wattage series *Champ* luminaires are used:

- In manufacturing plants, refineries, chemical, petrochemical, and other industrial process facilities, waste or sewage treatment facilities, and other heavy industrial applications
- In applications involving medium and high mounting heights
- In applications where energy-efficient, high lumen output is required
- In areas in which ignitable concentrations of flammable gases or vapors will be present only due to abnormal, unusual, or accidental conditions
- In marine applications where water spray and corrosive atmospheres are considerations
- In elevated ambient temperatures often found in industrial applications
- In installations where moisture, dirt, dust, vibration, corrosion and rough usage are problems
- Wherever the damaging effects of water, wind, snow, sleet, hot sun, or any combination of these elements, are problems

Features:

- Cast copper-free aluminum construction (less than 0.4 of 1% copper) and epoxy powder finish provide excellent resistance to corrosion
- Six mounting arrangements to suit any lighting layout – pendant, ceiling, wall bracket, angle stanchion, straight stanchion and quad-mount
- Wide range of light sources and wattages to meet specifiers' needs: 200, 250, 400 watt high pressure sodium (HPS); 250 and 400 watt metal halide (MH) and pulse start metal halide
- Hinged ballast housing for ease of installation and maintenance
- Wide choice of photometric distributions. Glass globes, glass refractors, and reflector/lens are available
- All luminaires designed to perform in a 40°C ambient temperature. Selected luminaires are suitable for ambient temperatures up to 65°C
- Superior gasketing seals between the mounting module, housing, and optical assembly for optimum performance in wet and corrosive environments
- Hubs with integral conduit stop and bushing to help prevent damage to field wiring during installation
- Low ambient capability to (-40°C)
- Dome and 30° angle reflectors made of bright white *Krydon*® material and etched Alzak® high bay reflectors provide superior reflectivity
- Grounding wire for safety
- High power factor ballasts (Min. P. F. 90%) are available in a variety of voltages to meet local area requirements
- Mogul base lamp socket

Certifications and Compliances:

- NEC/CEC:
 - Class I, Division 2, Groups A, B, C, D
 - With Glass Refractor - Class II, Class III & Simultaneous Presence (Class I, Division 2 and Class II)
 - Class I, Zone 2
- IEC:
 - Zone 2 Ex nR IIC
- UL Standards:
 - 844 Hazardous (Classified) Locations
 - 1598 Luminaires
 - 1598A Marine Locations
- CSA Standards:
 - C22.2 No. 137
- IEC Standards:
 - 60079-15

Crouse-Hinds

by **E.T.N**

Standard Materials:

- Ballast housings and mountings – copper-free aluminum (less than 0.4 of 1%)
- Exterior hardware and guards – stainless steel
- Reflectors (dome and angle) – *Krydon* fiberglass-reinforced polyester material
- Globes – heat and impact resistant internally fluted glass
- Refractors – glass
- Reflector lens – spun Alzak aluminum, tempered glass, stainless steel door frame



Standard Finishes:

- Copper-free aluminum – epoxy powder coat
- Alzak aluminum – natural
- Stainless steel – natural
- *Krydon* material – high reflectance white

Options:

The following special options are available from the factory by adding suffix to luminaire Cat. No.:

Description	Suffix
• Restricted Breathing Construction.....	S826‡
• Class I, Division 2 & Zone 2 Suitability Cooler Operating Temperatures (T-Numbers)	
• Certified for IEC Zone 2.....	S826TB‡
• Furnished with terminal block crimp terminals and dedicated voltage ballasts (no MT, DT, or TT)	
• Fused – to protect ballast and capacitors against abnormal line conditions (Not available with /MT ballast) (Not suitable for marine applications).....	S658†*
• Quick-Clip - Holds weight of housing when closed. No need to support luminaire while screwing the housing to the cover.....	S890
• Quartz auxiliary lighting – comes to full brightness immediately and remains lit until the HID lamp attains 60–70% of full illumination. For <i>non-hazardous</i> locations only.....	QTZ
• Ballast-Gard™ starter cutout switch – prevents starter pulsing when lamp is cycling or inoperative; prolongs ballast and ignitor life. Available for use with 200–400W HPS only.....	BG
• Factory assembled with H.I.D. lamps installed for additional labor savings.....	FA
• Top hat with stainless steel threaded insert to attach ballast housing.....	S806

Note: (Quartz lamp not included use 100W single ended lamp – Q100DC, Q100CL/DC, or 100Q/CL/DC). Consult factory for top-hat limitations.

Electrical Ratings:

- 120 to 600 volts and multi-tap
- 200, 250, 400W HPS and MH

Accessories:

- See pages 1022–1023 for complete listing.

Alzak is a registered trademark of ALCOA.

*When ordering fuses for luminaires, option S658, you must specify the operating voltage. S658 cannot be ordered with /MT in the catalog number.

†Not for use in Canada.

‡Suffix S826 and S826TB cannot be used with GRD4 Reflector/Lens.



3L VMV High Wattage Series 200-400W High Pressure Sodium

For Medium and High Mounting Heights
Champ® H.I.D. Luminaires

Cl. I, Div. 2, Groups A, B, C, D
Restricted Breathing Cl. I,
Div. 2 & Zone 2 (Suffix S826)
Certified for IEC Zone 2
(Suffix S826TB)

Cl. II, Groups E, F, G; Cl. III &
Simultaneous Presence
(with Glass Refractor)
Marine (with Globe or Glass
Refractor) & Wet Locations
3, 3R, 4, 4X; IP56 to IP66

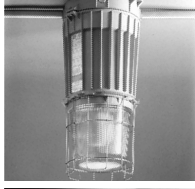
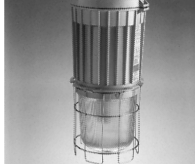
To complete the catalog #, include information in notes 1 and 2 below. For guards and other optics see VMV High Wattage Series - Ordering By Components page.

	Mounting Style	Hub Size	Lamp Watts	BASIC CATALOG NUMBER		
				With G303 Globe and P33 Guard	With GR305 Glass Refractor *	With GRD4 Reflector/Lens
	Pendant Mount (Rigid or Flexible)	3/4	200	VMVS2A200GP	VMVS2A200GR305	VMVS2A200GRD4
		1		VMVS3A200GP	VMVS3A200GR305	VMVS3A200GRD4
		3/4	250	VMVS2A250GP	VMVS2A250GR305	VMVS2A250GRD4
		1		VMVS3A250GP	VMVS3A250GR305	VMVS3A250GRD4
		3/4	400	VMVS2A400GP	VMVS2A400GR305	VMVS2A400GRD4
		1		VMVS3A400GP	VMVS3A400GR305	VMVS3A400GRD4
	Ceiling Mount Thru-Feed	3/4	200	VMVS2C200GP	VMVS2C200GR305	VMVS2C200GRD4
		1		VMVS3C200GP	VMVS3C200GR305	VMVS3C200GRD4
		3/4	250	VMVS2C250GP	VMVS2C250GR305	VMVS2C250GRD4
		1		VMVS3C250GP	VMVS3C250GR305	VMVS3C250GRD4
		3/4	400	VMVS2C400GP	VMVS2C400GR305	VMVS2C400GRD4
		1		VMVS3C400GP	VMVS3C400GR305	VMVS3C400GRD4
	Wall Mount Thru-Feed	3/4	200	VMVS2TW200GP	VMVS2TW200GR305	
		1		VMVS3TW200GP	VMVS3TW200GR305	
		3/4	250	VMVS2TW250GP	VMVS2TW250GR305	
		1		VMVS3TW250GP	VMVS3TW250GR305	
		3/4	400	VMVS2TW400GP	VMVS2TW400GR305	
		1		VMVS3TW400GP	VMVS3TW400GR305	
	Quad-Mount Pendant, Adjustable Thru-Feed, 25° Angle, 12 1/2° Angle	3/4	200	VMVS25Q200GP	VMVS25Q200GR305	VMVS25Q200GRD4
		3/4	250	VMVS25Q250GP	VMVS25Q250GR305	VMVS25Q250GRD4
		3/4	400	VMVS25Q400GP	VMVS25Q400GR305	VMVS25Q400GRD4
	Stanchion Mount 25° Angle	1 1/2	200	VMVSJ200GP	VMVSJ200GR305	VMVSJ200GRD4
		1 1/2	250	VMVSJ250GP	VMVSJ250GR305	VMVSJ250GRD4
		1 1/2	400	VMVSJ400GP	VMVSJ400GR305	VMVSJ400GRD4
	Stanchion Mount Straight	1 1/2	200	VMVSP200GP	VMVSP200GR305	
		1 1/2	250	VMVSP250GP	VMVSP250GR305	
		1 1/2	400	VMVSP400GP	VMVSP400GR305	

* For GR302 Type II Refractor, change "GR305" at end of catalog number to "GR302". Ex. VMVS2A200GR302
For GR303 Type III Refractor, change "GR305" at end of catalog number to "GR303". Ex. VMVS2A200GR303

1. Add voltage suffix to end of catalog number
Standard Voltage Ballasts - 60Hz

Voltage Suffix	NEC/UL			CEC/CSA (cUL)	
	Multi Tap /MT	120V /120	480V /480	Tri Tap /TT	120V /120

Optional Voltage Ballasts - 50 or 60Hz

Voltage Suffix	CEC/CSA (cUL) - CWI Isolated Ballasts				EXPORT			
	208V CWI /208CWI	240V CWI /240CWI	480V CWI /480CWI	600V CWI /600CWI	220V 60Hz /220	220V 50Hz /220 50	230V 50Hz /230 50	240V 50Hz /240 50

2. Options - Add the required option suffixes, see page 989, in alpha-numeric order.

VMV High Wattage Series 250-400W Pulse Start Metal Halide

For Medium and High Mounting Heights
Champ® H.I.D. Luminaires

Cl. I, Div. 2, Groups A, B, C, D
 Restricted Breathing Cl. I,
 Div. 2 & Zone 2 (Suffix S826)
 Certified for IEC Zone 2
 (Suffix S826TB)

Cl. II, Groups E, F, G; Cl. III &
 Simultaneous Presence
 (with Glass Refractor)
 Marine (with Globe or Glass
 Refractor) & Wet Locations
 3, 3R, 4, 4X; IP56 to IP66

3L

To complete the catalog #, include information in notes 1 and 2 below. For guards and other optics see VMV High Wattage Series - Ordering By Components page.

Mounting Style	Hub Size	Lamp Watts	BASIC CATALOG NUMBER		
			With G303 Globe and P33 Guard	With GR305 Glass Refractor *	With GRD4 Reflector/Lens
Pendant Mount (Rigid or Flexible)	3/4	250	VMVM2A250GP S828	VMVM2A250GR305 S828	VMVM2A250GRD4 S828
	1	250	VMVM3A250GP S828	VMVM3A250GR305 S828	VMVM3A250GRD4 S828
	3/4	320	VMVM2A320GP S828	VMVM2A320GR305 S828	VMVM2A320GRD4 S828
	1	320	VMVM3A320GP S828	VMVM3A320GR305 S828	VMVM3A320GRD4 S828
	3/4	400**	VMVM2A400GP S828	VMVM2A400GR305 S828	VMVM2A400GRD4 S828
Ceiling Mount Thru-Feed	3/4	250	VMVM2C250GP S828	VMVM2C250GR305 S828	VMVM2C250GRD4 S828
	1	250	VMVM3C250GP S828	VMVM3C250GR305 S828	VMVM3C250GRD4 S828
	3/4	320	VMVM2C320GP S828	VMVM2C320GR305 S828	VMVM2C320GRD4 S828
	1	320	VMVM3C320GP S828	VMVM3C320GR305 S828	VMVM3C320GRD4 S828
	3/4	400**	VMVM2C400GP S828	VMVM2C400GR305 S828	VMVM2C400GRD4 S828
Wall Mount Thru-Feed	3/4	250	VMVM2TW250GP S828	VMVM2TW250GR305 S828	VMVM2TW250GRD4 S828
	1	250	VMVM3TW250GP S828	VMVM3TW250GR305 S828	VMVM3TW250GRD4 S828
	3/4	320	VMVM2TW320GP S828	VMVM2TW320GR305 S828	VMVM2TW320GRD4 S828
	1	320	VMVM3TW320GP S828	VMVM3TW320GR305 S828	VMVM3TW320GRD4 S828
	3/4	400**	VMVM2TW400GP S828	VMVM2TW400GR305 S828	VMVM2TW400GRD4 S828
Quad-Mount Pendant, Adjustable Thru-Feed, 25° Angle, 12 1/2° Angle	3/4	250	VMVM25Q250GP S828	VMVM25Q250GR305 S828	VMVM25Q250GRD4 S828
	3/4	320	VMVM25Q320GP S828	VMVM25Q320GR305 S828	VMVM25Q320GRD4 S828
	3/4	400**	VMVM25Q400GP S828	VMVM25Q400GR305 S828	VMVM25Q400GRD4 S828
Stanchion Mount 25° Angle	1 1/2	250	VMVMJ250GP S828	VMVMJ250GR305 S828	VMVMJ250GRD4 S828
	1 1/2	320	VMVMJ320GP S828	VMVMJ320GR305 S828	VMVMJ320GRD4 S828
	1 1/2	400**	VMVMJ400GP S828	VMVMJ400GR305 S828	VMVMJ400GRD4 S828
Stanchion Mount Straight	1 1/2	250	VMVMP250GP S828	VMVMP250GR305 S828	VMVMP250GRD4 S828
	1 1/2	320	VMVMP320GP S828	VMVMP320GR305 S828	VMVMP320GRD4 S828
	1 1/2	400**	VMVMP400GP S828	VMVMP400GR305 S828	VMVMP400GRD4 S828

* For GR302 Type II Refractor, change "GR305" at end of catalog number to "GR302". Ex. VMVM2A250GR302-S828
 For GR303 Type III Refractor, change "GR305" at end of catalog number to "GR303". Ex. VMVM2A250GR303-S828
 ** To be used with ED28 (bulb shaped lamp).

1. Add voltage suffix to end of catalog number
 Standard Voltage Ballasts - 60Hz

Voltage Suffix	NEC/UL		CEC/CSA (cUL)	
	Multi Tap /MT	120V /120 480V /480	Tri Tap /TT	120V /120
Optional Voltage Ballasts - 50 or 60Hz				
EXPORT				
Voltage Suffix	220V 60Hz /220	220V 50Hz /220 50	230V 50Hz /230 50	240V 50Hz /240 50

2. Options - Add the required option suffixes, see page 989, in alpha-numeric order.

Lamp Selection Table:

Fixture	Lamp Type	Bulb	Venture	Phillips	Sylvania
			MP 320W/BU/ED28/UVS/PS/EM/950	MS320/U/PS	MS320/PS/BU-HOR
VMVM320GP	320W PS MH	ED28, BT28	MP 320W/BU/ED28/UVS/PS/740	MS320/C/BU/PS	-
			MP 320W/C/BU/ED28/EVS/PS/737	-	-
VMVM400GP	400W PS MH	ED28, BT28	MP 400W/BU/ED28/UVS/PS/EM/950	N/A	M400/PS/U/BT28

3L VMV High Wattage Series 250-400W Metal Halide

For Medium and High Mounting Heights
Champ® H.I.D. Luminaires

Cl. I, Div. 2, Groups A, B, C, D
Restricted Breathing Cl. I,
Div. 2 & Zone 2 (Suffix S826)
Certified for IEC Zone 2
(Suffix S826TB)

Cl. II, Groups E, F, G; Cl. III &
Simultaneous Presence
(with Glass Refractor)
Marine (with Globe or Glass
Refractor) & Wet Locations
3, 3R, 4, 4X; IP56 to IP66

To complete the catalog #, include information in notes 1 and 2 below. For guards and other optics see VMV High Wattage Series - Ordering By Components page.

Mounting Style	Hub Size	Lamp Watts	BASIC CATALOG NUMBER		
			With G303 Globe and P33 Guard	With GR305 Glass Refractor *	With GRD4 Reflector/Lens
 Pendant Mount (Rigid or Flexible)	3/4	250	VMVM2A250GP	VMVM2A250GR305	VMVM2A250GRD4
	1		VMVM3A250GP	VMVM3A250GR305	VMVM3A250GRD4
	3/4	400	N/A	VMVM2A400GR305	VMVM2A400GRD4
	1		N/A	VMVM3A400GR305	VMVM3A400GRD4
 Ceiling Mount Thru-Feed	3/4	250	VMVM2C250GP	VMVM2C250GR305	VMVM2C250GRD4
	1		VMVM3C250GP	VMVM3C250GR305	VMVM3C250GRD4
	3/4	400	N/A	VMVM2C400GR305	VMVM2C400GRD4
	1		N/A	VMVM3C400GR305	VMVM3C400GRD4
 Wall Mount Thru-Feed	3/4	250	VMVM2TW250GP	VMVM2TW250GR305	
	1		VMVM3TW250GP	VMVM3TW250GR305	
	3/4	400	N/A	VMVM2TW400GR305	
	1		N/A	VMVM3TW400GR305	
 Quad-Mount Pendant, Adjustable Thru-Feed, 25° Angle, 12½° Angle	3/4	250	VMVM25Q250GP	VMVM25Q250GR305	VMVM25Q250GRD4
	3/4	400	N/A	VMVM25Q400GR305	VMVM25Q400GRD4
 Stanchion Mount 25° Angle	1½	250	VMVMJ250GP	VMVMJ250GR305	VMVMJ250GRD4
	1½	400	N/A	VMVMJ400GR305	VMVMJ400GRD4
 Stanchion Mount Straight	1½	250	VMVMP250GP	VMVMP250GR305	
	1½	400	N/A	VMVMP400GR305	

* For GR302 Type II Refractor, change "GR305" at end of catalog number to "GR302". Ex. VMVM2A250GR302
 For GR303 Type III Refractor, change "GR305" at end of catalog number to "GR303". Ex. VMVM2A250GR303

1. Add voltage suffix to end of catalog number
 Standard Voltage Ballasts - 60Hz

Voltage Suffix	Multi Tap /MT	NEC/UL		CEC/CSA (cUL)	
		120V /120	480V /480	Tri Tap /TT	120V /120

Optional Voltage Ballasts - 50 or 60Hz

Voltage Suffix	CEC/CSA (cUL) - CWI Isolated Ballasts			EXPORT			
	208V CWI /208CWI	240V CWI /240CWI	600V CWI /600CWI	220V 60Hz /220	220V 50Hz /220 50	230V 50Hz /230 50	240V 50Hz /240 50

2. Options - Add the required option suffixes, see page 989, in alpha-numeric order.

VMV High Wattage Series – Ordering by Components

3L

VMV High Wattage Luminaires are available in components.

A complete luminaire consists of:

- I. Champ Cover (Mounting Module)
- II. VMV Ballast Housing – Include voltage and required option(s)
- III. Optical & Guard Components – Globe, Reflector, Refractor, Guard

I. Champ Cover (Mounting Module):

Type	Conduit	Cat. #
Pendant	3/4"	APM2
	1"	APM3
Ceiling	3/4"	CM2
	1"	CM3
Wall	3/4"	TWM2
	1"	TWM3
Stanchion – 25 Degree Angle	1 1/2"	JM5
Stanchion – Straight	1 1/2"	PM5
Quad-Mount	3/4"	QM25

II. Ballast Housings:

Complete catalog number must have the **voltage suffix** (MT shown) and any **options suffixes**.

Lamp Type	Lamp Watts	Cat. #
High Pressure Sodium	200	VMVS200/MT
	250	VMVS250/MT
	400	VMVS400/MT
Metal Halide	250	VMVM250/MT
	400	VMVM400/MT

III. Globe, Reflectors, Refractors, Guards:

Type	Cat. #
Globe	G303
Globe Guard	P33
Reflector – Dome	RD739
Reflector – Angle	RA739
Refractor – Type 2	GR302
Refractor – Type 3	GR303
Refractor – Type 5	GR305
Refractor Guard	P23
High Bay Reflector/Lens	GRD4



Champ® H.I.D. Luminaires

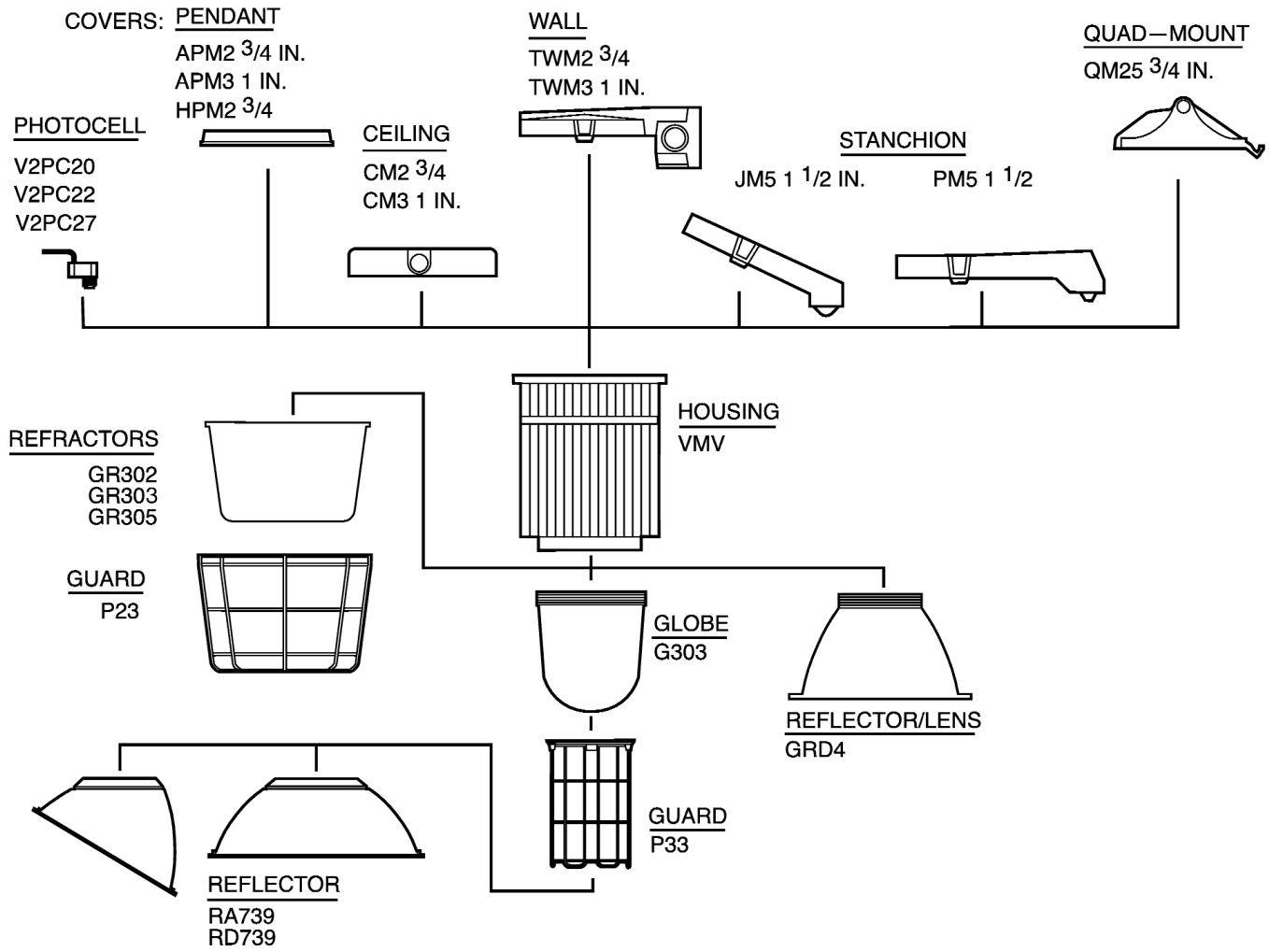

3L

Champ® H.I.D. Luminaires

Lamp Watts	Ambient Temp C	Optics	Class I (Gas/Vapors)			Class II (Dust) and Class III	Simultaneous Presence Gas and Dust Present in the Same Area		Supply Wire Temp C
			Non Restricted Breathing	Restricted Breathing			Non Restricted Breathing	Restricted Breathing	
				Ex nR				Ex nR	
			Standard Product	Option S826(TB)		Standard Product	Standard Product	Option S826	
			Division 2	Zone 2 or Division 2		Standard Product	Class I, Division 2 and Class II	Class I, Zone 2 or Division 2 and Class II	
		G303	X	-	-	X	-	-	-
		GR305	-	X	-	-	X	-	X
		GRD4	-	-	X	-	-	-	-

High Pressure Sodium

200	40	325 C	350 C	T2	T3	T4	T3C	T1/T3C	T3C	75
	55	325 C	350 C	T2	T3	T4	-	-	-	75
	65	325 C	350 C	T2	T3	-	-	-	-	85
250	40	350 C	350 C	325 C	T3	T4	T3C	T1/T3C	T3C	75
	55	350 C	350 C	350 C	T3	T4	-	-	-	85
	65	350 C	350 C	-	T3	-	-	-	-	-
400	40	350 C	350 C	T1	T3	T4	T3C	T1/T3C	T3C	85
	55	350 C	350 C	T1	T3	T4	-	-	-	90

Metal Halide

200	40	350 C	325 C	350 C	T3	T4	T3B	350 C/T3B	T3B	85
	55	350 C	350 C	350 C	T3	T4	-	-	-	90
250	40	350 C	325 C	350 C	T3	T4	T3B	350 C/T3B	T3B	85
	55	350 C	350 C	350 C	T3	T4	-	-	-	90
400	40	-	325 C	T1	-	T4	T3B	350 C/T3B	T3B	85
	55	-	350 C	T1	-	-	-	-	-	-

Pulse Start Metal Halide (S828)

250	40	350 C	350 C	325 C	T3	T4	T3B	350 C/T3B	T3B	85
	55	350 C	350 C	350 C	T3	T4	-	-	-	90
320	40	T1	325 C	T2A	T3	-	-	-	-	90
400	40	T1	T1	T1	T3	T4	-	-	-	90



Champ® H.I.D. Luminaires

Dimensions

In Inches:

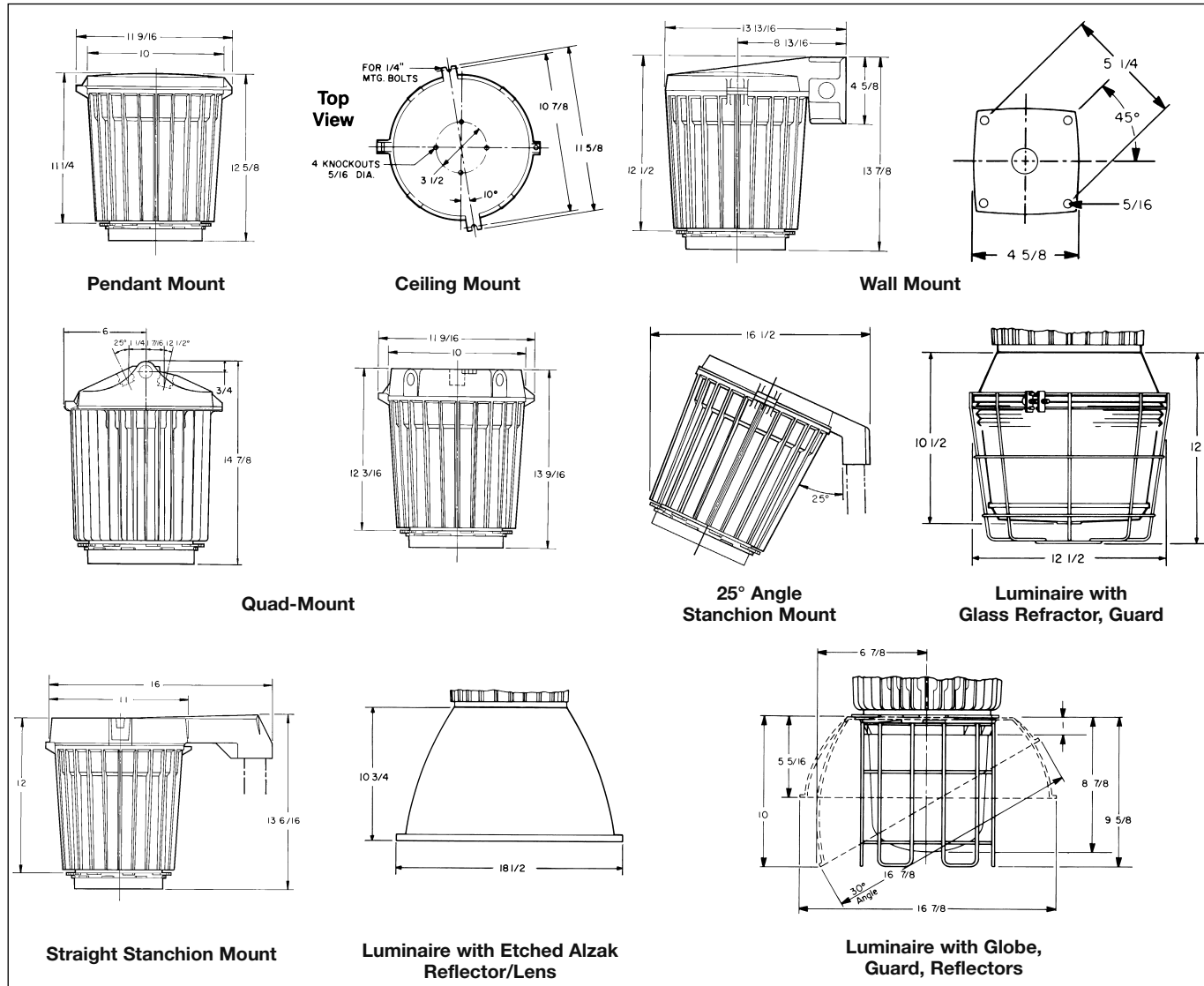

Net Luminaire Weights (lbs.):

Luminaire Series	Lamp Watts	Luminaire with:		
		Globe, Guard (lbs.)	Reflector/Lens	Glass Refractor (lbs.)
VMVS	200	29 1/2	30	32 1/2
	250	29 1/2	30	32 1/2
	400	38 1/2	39	41 1/2
VMVM	250	32 1/2	33	35 3/4
	400		34	35 1/2

Type	Lbs.	Type	Lbs.
Add for mounting modules:			
Pendant	1 1/4	Quad-Mount	3 1/2
Ceiling	2 3/4	Angle Stanchion	3 1/2
Wall	4 1/2	Straight Stanchion	4 1/2

Add for reflectors:			
Dome	1 1/2	30° Angle	1 1/2
High Bay	1 3/4		

Deduct: 1 1/2 lb. for luminaire without P33 Guard

Champ® H.I.D. Luminaires

Lamp: 250W/E-18 high pressure sodium (HPS)
 Total bare lamp lumens: 27500

Note: All data provided is for high pressure sodium luminaires with 250W/E-18 clear lamps. Use conversion factors (multipliers) shown below for other clear lamp types and wattages. Consult Eaton's Crouse-Hinds for additional photometric data on any Champ series luminaire.

Luminaire with Globe and Dome Reflector

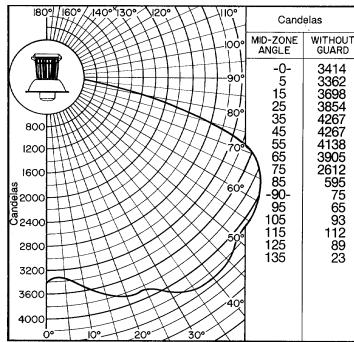

Multipliers (for use with candela curve only).

Luminaire Series	Lamp Watts	Conversion Factor
VMVS	200	0.80
	400	1.82

Luminaire spacing ratio: 2.0

Coefficient of Utilization

Effective Floor Cavity Reflectance 20%

% Reflectance Eff. Ceil.	Wall	Room Cavity Ratio				
		1	2	3	4	5
80	50	.750	.640	.550	.476	.416
	30	.711	.582	.482	.402	.341
	10	.677	.532	.429	.346	.285
70	50	.732	.625	.538	.465	.405
	30	.696	.570	.474	.397	.335
	10	.664	.526	.424	.343	.282
50	50	.695	.594	.513	.443	.388
	30	.666	.549	.458	.384	.326
	10	.641	.509	.414	.336	.279
30	50	.663	.567	.490	.423	.371
	30	.640	.530	.443	.372	.316
	10	.618	.496	.405	.330	.273
10	50	.635	.542	.469	.405	.355
	30	.615	.510	.429	.360	.307
	10	.597	.483	.395	.323	.268
0	0	.580	.464	.377	.305	.251
% Reflectance Eff. Ceil.	Wall	Room Cavity Ratio				
		6	7	8	9	10
80	50	.369	.327	.290	.263	.229
	30	.295	.255	.222	.196	.163
	10	.243	.208	.173	.150	.121
70	50	.360	.320	.285	.258	.224
	30	.291	.251	.219	.193	.163
	10	.239	.204	.172	.149	.121
50	50	.344	.306	.272	.247	.216
	30	.283	.243	.213	.189	.159
	10	.236	.200	.170	.147	.119
30	50	.330	.292	.262	.238	.207
	30	.275	.238	.207	.183	.154
	10	.233	.196	.167	.145	.116
10	50	.317	.282	.251	.229	.200
	30	.267	.233	.202	.179	.150
	10	.229	.194	.165	.142	.114
0	0	.212	.178	.149	.128	.101



3L Luminares with Induction Lighting System

VMVIG and DMVIG Series

Cl. I, Div. 2, Groups A, B, C, D
Cl. I, Zone 2, Group IIC
Restricted Breathing Suffix
S826 for Cl. I, Div. 2 & Zone 2

Enclosure Type 4X, IP66
Wet Locations
Marine Locations
UL and cUL Listed

Get uninterrupted light for up to 11 years, without changing a lamp.

Eaton's Crouse-Hinds Champ Luminaire with Induction Light Source delivers up to 100,000 hours of white light in a hazardous location, corrosion-resistant watertight package. That's 5 to 8 times the typical life of conventional fluorescent or HID lamps. And, with no maintenance required for up to 11 years, you'll reduce your maintenance and lamp replacement costs.

Compelling reasons to choose the new Champ Induction Luminaire as the light source for industrial and hazardous locations include:

- Crisp, white light (80+ color rendering index) provides increased safety by clearly illuminating signs, instrument panels, equipment and more with vibrant natural colors.
- Up to 100,000 hours of lamp life minimizes routine maintenance costs. If you operate this luminaire for 24 hours, 7 days a week, you will not need to change the lamp for up to 11 years!
- Instant illumination — no waiting for lamp warm-up time. Increases productivity and safety.
- Delivers the best possible luminaire temperature rating — T6 (85°C) when used with the Champ restricted breathing option. Ideal for hazardous areas where a low ignition temperature is required.
- Starts in low temperatures — as low as -40°C.

Additional Features and Benefits:

The Champ Induction Luminaire is suitable for Class I, Division 2 and Zone 2 areas with the assurance of Eaton's Crouse-Hinds quality and reliability. They are ideal for use in hard-to-reach applications and where process requirements demand continuous luminaire operation.

Features:

- High lumens per watts (72 lpw for the 165W Champ) will save energy
- Retains strong light output (retains more than 70% output) throughout the life of the lamp
- Will not add electrical noise to the circuits — Total Harmonic Distortion is less than 10%
- Excellent power factor of .96 increases useable watts to an excellent level and reduces energy consumption
- Internal electronics are enclosed to ensure that there is no interference with external instrumentation



165W Champ Induction provides as much light as a 175W Metal Halide but lasts 7 times longer!

Luminaires with Induction Lighting System

VMVIG and DMVIG Series with Lamps Included

Cl. I, Div. 2, Groups A, B, C, D
 Cl. I, Zone 2, Group IIC
 Restricted Breathing Suffix
 S826 for Cl. I, Div. 2 & Zone 2

Enclosure Type 4X, IP66
 Wet Locations
 Marine Locations
 UL and cUL Listed

3L

Applications:

Champ Induction Luminaires are ideal:

- Where an extra long life lamp source (up to 100,000 hours) is required.
- In areas that require lamps to reach full illumination immediately.
- Where cool temperature ratings on the luminaire globe are needed to ensure safe operation in hazardous areas.
- In hard-to-reach applications where relamping is costly.
- Where luminaire maintenance is difficult due to continuous process operation requirements that restrict or prohibit shut down except in emergency situations.
- To provide a cost-effective lighting system (low installed/life cost) by minimizing or even eliminating routine luminaire maintenance.
- In cold environment applications.

Certifications and Compliances:

- NEC & CEC:
 - Class I, Division 2 and Zone 2
 - Class I, Division 2, Groups A, B, C, D
 - Class I, Zone 2, Group IIC
- Restricted Breathing Suffix S826 for Class I, Division 2 and Zone 2
- Marine Locations, Wet Locations, Enclosure Type 3, 3R, 4, 4X; IP66
- UL and cUL Listed / ETL
- UL Standards: 844, 60079-15, 1598, 1598A
- CSA Standards: C22.2 No.137, E79 Series

Compliances and approvals for the lamp system

- RFI < 30 MHz EN 55015
- RFI > 30 MHz EN 55022
- Harmonics EN 61000-3-2
- Immunity EN 61547
- Safety EN 61347-2-3 & UL935
- Performance EN 60928
- Vibration & bump tests EN 60929
- IEC 68-2-6-Fc
- IEC 68-2-29-Eb
- Quality standards ISO 9001
- Environmental standard ISO 14001

Standard Materials:

- Ballast housings and mountings – copper-free aluminum (less than 0.4 of 1%)
- Exterior hardware – stainless steel
- Reflectors (dome and angle) – Krydon fiberglass-reinforced polyester material
- Globes – heat and impact-resistant internally fluted glass
- Guards – copper-free aluminum (55W), stainless steel (85W)

Standard Finishes:

- Copper-free aluminum – epoxy powder coat
- Krydon® material – high reflectance white
- Stainless steel – natural

Options:

Description	Suffix
Restricted Breathing Construction Class I, Division 2 & Zone 2 suitability Cooler operating temperatures (T-Codes) Corrected color temperature lamp - 4000K	S826 S887

Accessories:

Mounting Modules	Cat. #
3/4 NPT Pendant	APM2
1 NPT Pendant	APM3
3/4 NPT Flexible Pendant	HPM2
3/4 NPT Ceiling Mount	CM2
1 NPT Ceiling Mount	CM3
3/4 NPT Wall Mount	TWM2
1 NPT Wall Mount	TWM3
3/4 NPT Quad Mount	QM25
1 1/2 NPT Stanchion Mount — 25 Degree Angle	JM5
1 1/2 NPT Stanchion Mount — Straight	PM5

Wattage	Dome Reflector Cat. #	Angle Reflector Cat. #
55W	RD70	RA70
85W	RD739	RA739
165W	RD739	RA739

Dimensions:

See Section 3L for dimensional information on VMV and DMV Series.

Amperage:

Power consumption for specific voltages

55W Luminaires

- a. 120VAC x .460mA = 55.70 watts
- b. 230VAC x .260mA = 59.80 watts

85W Luminaires

- c. 120VAC x .710mA = 85.20 watts
- d. 230VAC x .400mA = 92.00 watts

165W Luminaires

- e. 120VAC x 1.35 = 162.00 watts
- f. 230VAC x .700mA = 161.00 watts



3L Luminaires with Induction Lighting System

VMVIG and DMVIG Series

Cl. I, Div. 2, Groups A, B, C, D
 Cl. I, Zone 2, Group IIC
 Restricted Breathing Suffix
 S826 for Cl. I, Div. 2 & Zone 2

Enclosure Type 4X, IP66
 Wet Locations
 Marine Locations
 UL and cUL Listed

Lamp Data:

	System Power (W)	Lumen (LM)		Efficacy (LM/W)		Color Rendering Index*	Lumen Maintenance After 60,000 Hrs (%)
		Initial	Mean	Initial	Mean		
VMV	55	3500	2800	65	51	80	75
DMV	85	6000	4800	70	57	80	75
DMV	165	12000	9600	72	58	80	70

*Lamp sources with 80+ CRI provide excellent color rendering. CRI scale is 0-100 with 100 considered as ideal.

Temperature Performance Data:

Cat. #	Watts	Ambient Temp. °C	Supply Wire Temp. °C	Class I, Div. 2 Temp. Rating	Class II, Div. 1, Class III Temp. Rating	Simultaneous Presence Class I, Div. 2	Restricted Breathing (Suffix S826) Aex nR IIC, Ex nR IIC Class I, Div. 2/Zone 2
VMVIG055	55	40	60	T2C	-	-	T6
VMVIG055	55	55	75	T2C	-	-	T5
DMVIG085	85	40	60	T3	T5	T2D	T6
DMVIG085	85	55	75	T2D	T4A	-	T5
DMVIG165	165	40	75	T3	-	-	T5

Champ Induction DMV 85 watt is now Class II, Div. 1 – suitable for dust environments.

Ordering Information:

To complete Catalog Number, add Voltage and Option suffix(es).

Mounting Style	Hub Size (Inches)	55W Induction Catalog Number (With G24 Globe & P21 Guard)	85W Induction Catalog Number (With G303 Globe & P33 Guard)	165W Induction Catalog Number (With G303 Globe & P33 Guard)
Pendant	3/4 1	VMVIG2A055GP VMVIG3A055GP	DMVIG2A085GP DMVIG3A085GP	DMVIG2A165GP DMVIG3A165GP
Flexible Pendant	3/4	VMVIG2HA055GP	DMVIG2HA085GP	DMVIG2HA165GP
Ceiling Mount	3/4 1	VMVIG2C055GP VMVIG3C055GP	DMVIG2C085GP DMVIG3C085GP	DMVIG2C165GP DMVIG3C165GP
Wall Mount	3/4 1	VMVIG2TW055GP VMVIG3TW055GP	DMVIG2TW085GP DMVIG3TW085GP	DMVIG2TW165GP DMVIG3TW165GP
Quad Mount	3/4	VMVIG25Q055GP	DMVIG25Q085GP	DMVIG25Q165GP
Stanchion Mount 25° Angle	1 1/2	VMVIGJ055GP	DMVIGJ085GP	DMVIGJ165GP
Stanchion Mount Straight	1 1/2	VMVIGP055GP	DMVIGP085GP	DMVIGP165GP
Luminaire with Globe and Guard less Mounting Module	-	VMVIG055GP	DMVIG085GP	DMVIG165GP

Add the voltage suffix to the above catalog number. Ex. - DMVIG2A085GP/120

Standard Voltage	Suffix	Range
120V, 50 / 60 Hz	/120	Operative range of 108-132 VAC
200V-277V, 50 / 60 Hz	/200 277	Operates on 208, 220, 230, 240, 277 VAC

3L

Luminaires with Induction Lighting System

VMVIG and DMVIG Series

55 Watt Induction

Luminaire With Globe And Guard
VMVIG055GP LAMP: 55W Induction

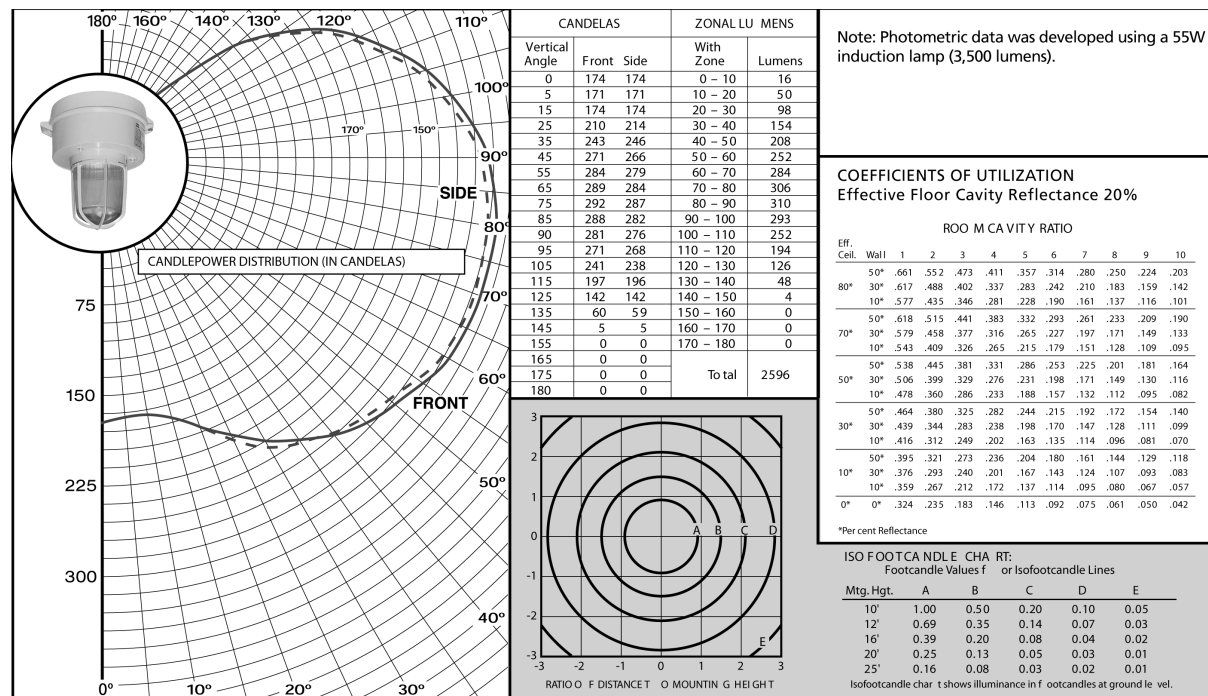

85 Watt Induction

Luminaire With Globe And Guard
DMVIG085GP LAMP: 85W Induction

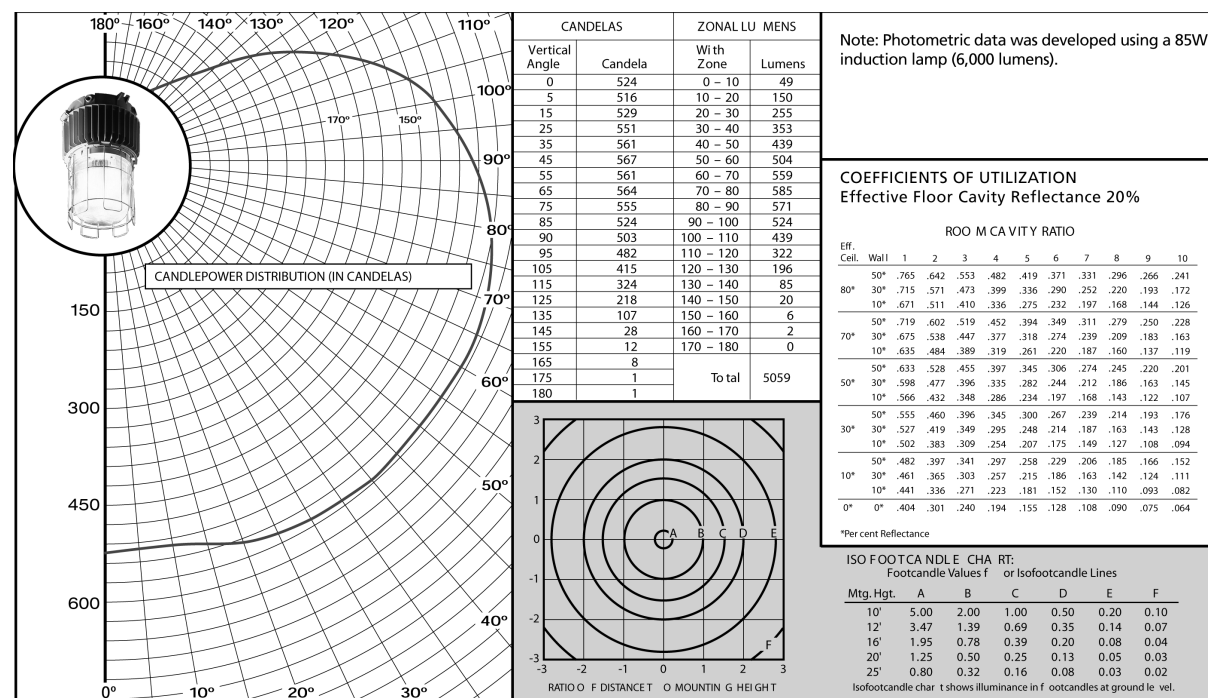

Photometric Data: For additional photometric information, see the Resources area of our website. Photometric .ies files for use with our Luxicon Lighting Layout Software are available to download.



165 Watt Induction

Luminaire With Globe

DMVIG165G Lamp: 165W Induction

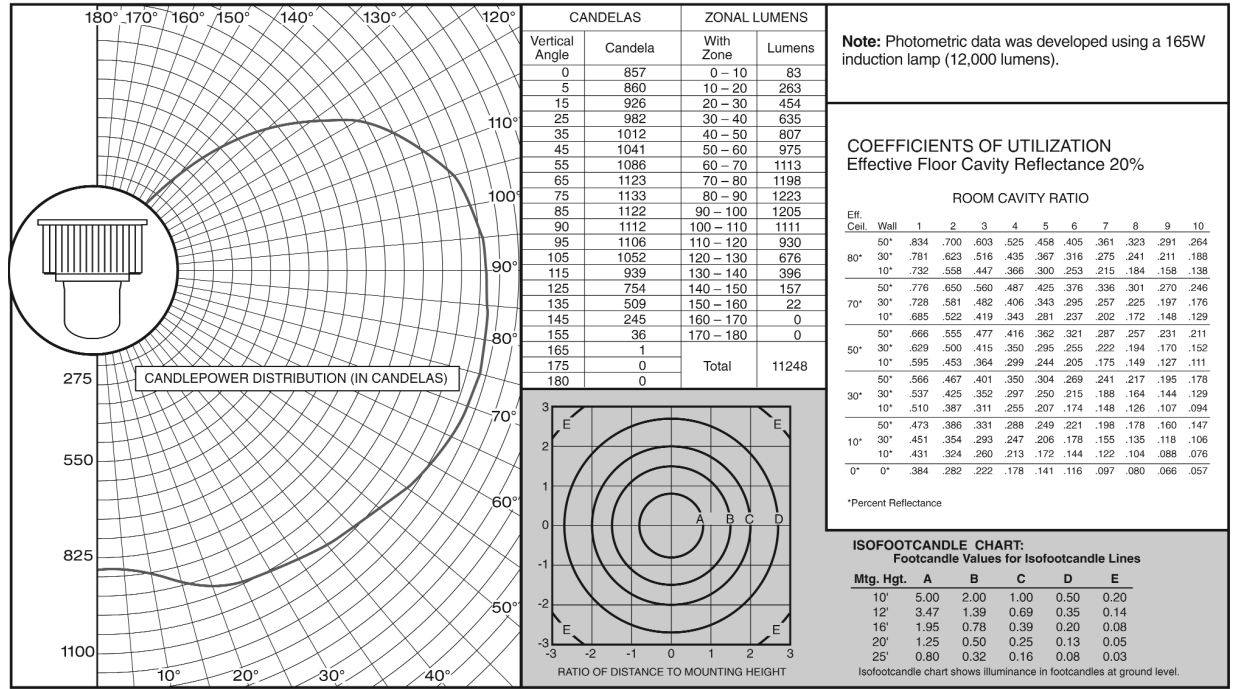

165 Watt Induction

Luminaire With Globe And Guard

DMVIG165GP Lamp: 165W Induction

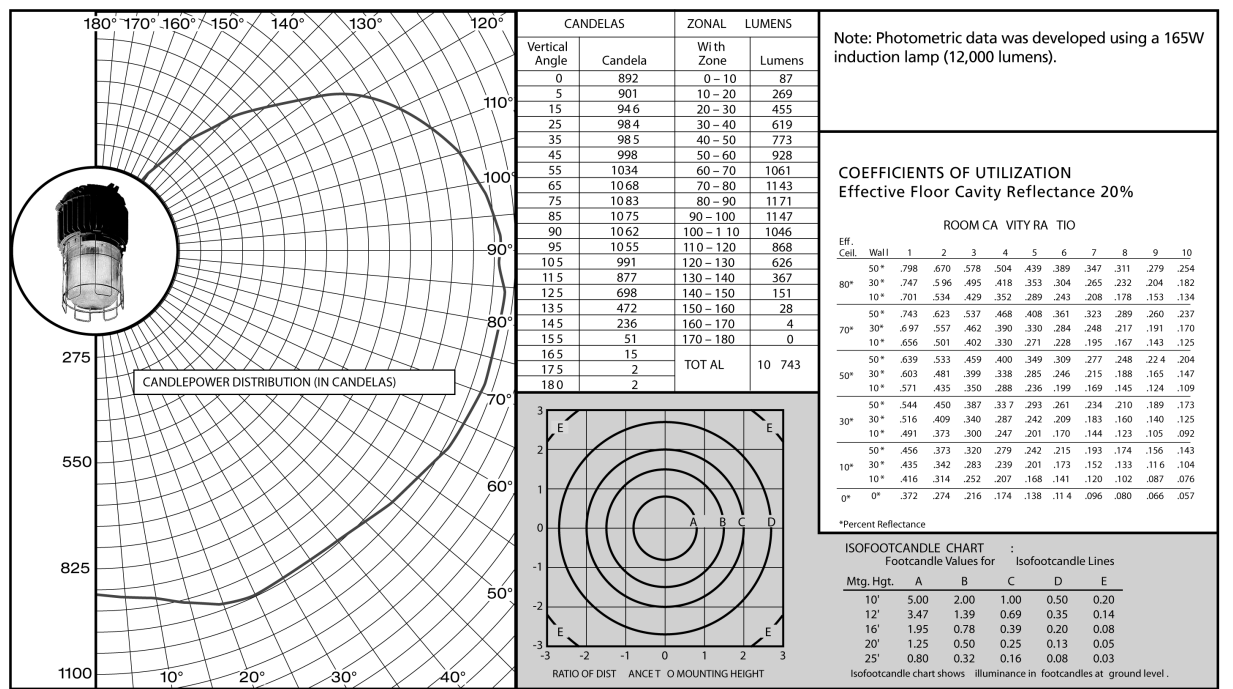

Photometric Data: For additional photometric information, see the Resources area of our website. Photometric .ies files for use with our Luxicon Lighting Layout Software are available to download.

Luminaires with Induction Lighting System

VMVIG and DMVIG Series

165 Watt Induction

Luminaire With Globe And RD739 Dome Reflector

DMVIG165G Lamp: 165W Induction

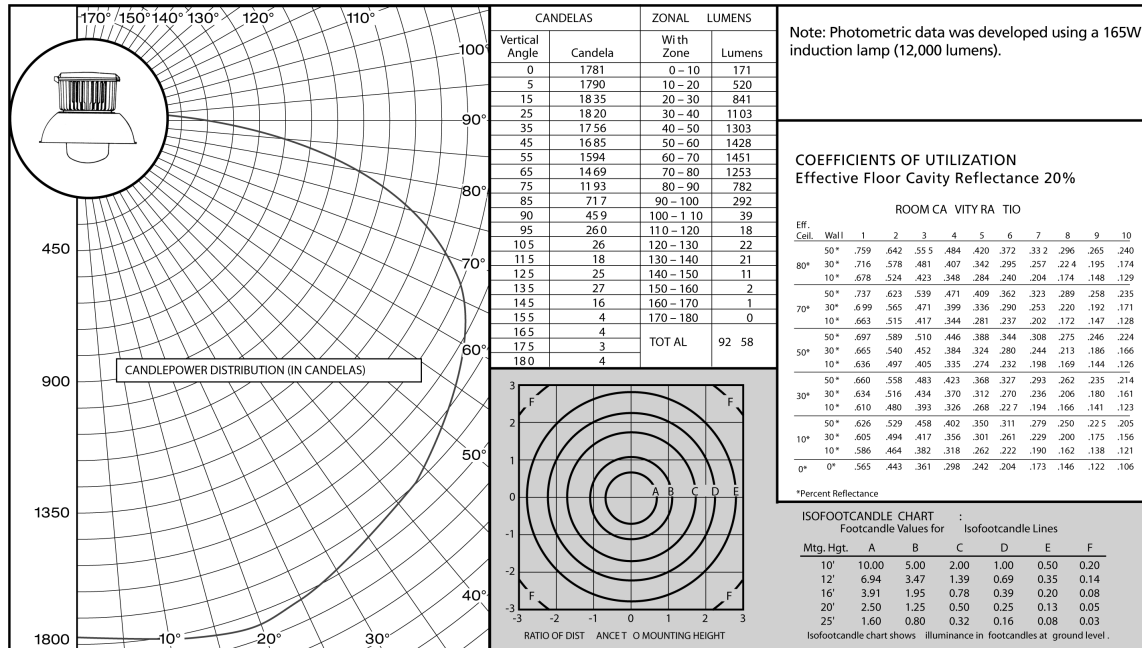

165 Watt Induction

Luminaire With Globe And RA739 (30° Angle) Reflector

DMVIG165G Lamp: 165W Induction

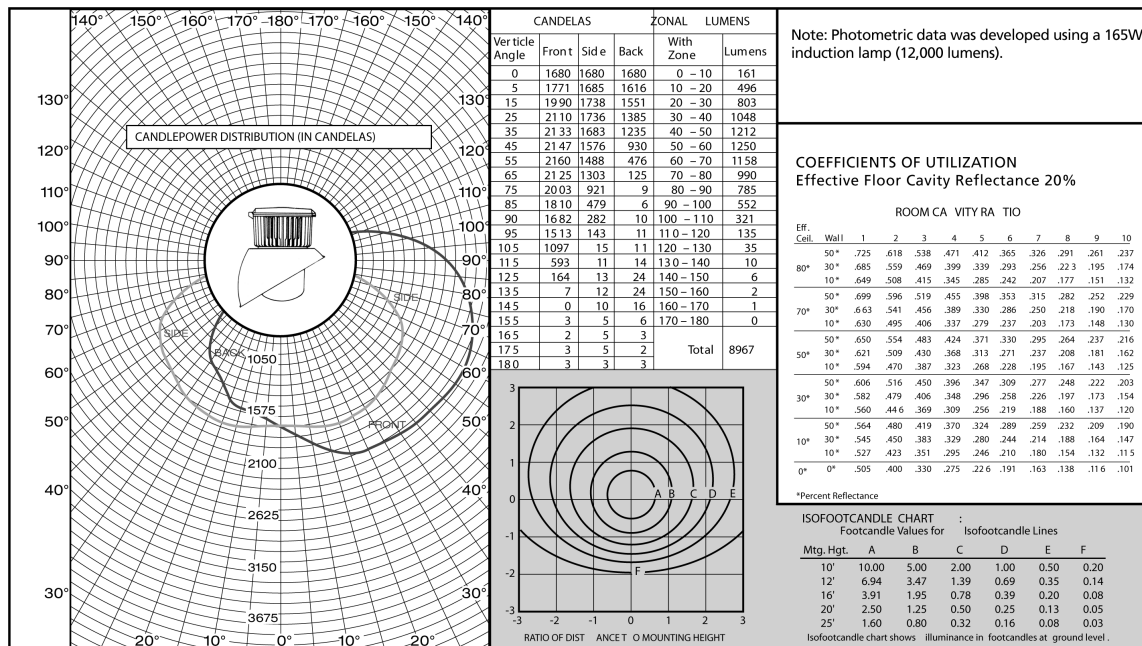

Photometric Data: For additional photometric information, see the Resources area of our website. Photometric .ies files for use with our Luxicon Lighting Layout Software are available to download.

3L Luminares with Induction Lighting System

Family Tree

VMVIG and DMVIG Series

COVERS:

PENDANT

- APM2 3/4 IN.
- APM3 1 IN.
- HPM2 3/4 IN.

WALL

- TWM2 3/4 IN.
- TWM3 1 IN.

QUAD—MOUNT

- QM25 3/4 IN.

CEILING

- CM2 3/4 IN.
- CM3 1 IN.

STANCHION

- JM5 1 1/2 IN.
- PM5 1 1/2 IN.

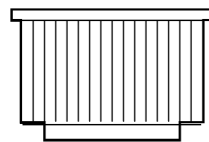

HOUSING
DMV

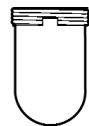

GLOBE
G303
G303 S808

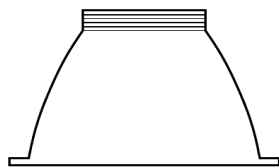

REFLECTOR/LENS
GRD4

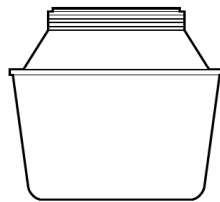

REFRACTOR
GR302 GR303
GR305
PGR302
PGR305
PGR303

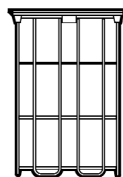

GUARD
P33

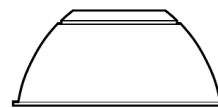

REFLECTOR
RA79 RA739
RD79 RD739

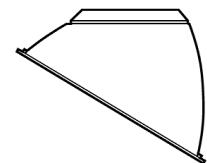

3L

N2MV Series 50-175W Non-metallic

Champ® H.I.D. Luminaires

Cl. I, Div. 2, Groups A, B, C, D
Cl. II, Groups F, G
Cl. III & Simultaneous
Presence (100W max)

Marine & Wet Locations
3, 3R, 4, 4X; IP56

3L

Applications:

N2MV series *Champ* luminaires are used:

- In areas in which ignitable concentrations of flammable gases or vapors will be present due to abnormal, unusual or accidental conditions.
- In installations where moisture, dirt, vibration, corrosion or rough usage are concerns.
- Wherever the damaging effects of water, wind, snow, sleet, hot sun or any combination of these elements are found.
- Ideal for marine use; resists the harmful effects of salt water.
- Withstands the harshest of corrosive environments.
- To provide low wattage spot and floodlighting.
- For general area lighting.
- In areas where the ambient temperature will get as low as 40°C (-40°F).
- In manufacturing plants, refineries, chemical, petrochemical and other industrial process facilities, wastewater and sewage treatment facilities, offshore, dockside and harbor installations as well as other heavy industrial applications.

Features:

- Housing and mounting modules made of polyphenylene sulfide (PPS) for strength and maximum resistance to corrosion.
- Pendant mounting module equipped with integral hub set screws for vibration resistance.
- Hubs are provided with an integral bushing to help prevent damage to field wiring during installation and ground connection for positive bonding.
- Guard, hub inserts, stanchion elbow and hardware made of stainless steel for maximum resistance to corrosion.
- Grounding wire for safety.
- Stainless steel open bottom guard permits direct access to the globe for easy relamping.
- Hinged assembly allows the luminaire to hang free during installation to permit the use of both hands when wiring.
- One external captive screw for ease of installation.
- Handle – hinge assembly doubles as a handle for ease of installation, especially when carrying up a ladder.



Certifications and Complies:

- NEC and CEC:
Class I, Division 2, Groups A, B, C, D
100W Maximum – Class II, Class III & Simultaneous Presence (Class I, Division 2 and Class II)
- UL Standards:
844 Hazardous (Classified) Locations
1598 Luminaires
1598A Marine Locations
- CSA Standards
C22.2 No. 137

Standard Materials:

- Housing, mounting modules, component pallets – polyphenylene sulfide (PPS)
- Guard, hub inserts, stanchion elbow, hardware – stainless steel
- Globe – heat tempered
- Gaskets – silicone rubber

Electrical Ratings:

- 120, multi-tap/MT (120, 208, 240 and 277), Dual-Tap/DT (120, 277 volts), Tri-Tap/TT (120, 277, 347 volts) 480 volt, 600 volt, 220 / 240 volt-50 Hz
- 50–150W HPS; 70–175W MH and Pulse Start MH

Options:

The following special options are available from the factory by adding suffix to luminaire Cat. No.:

Description	Suffix
• Wall Mount Arm. For converting ceiling mount luminaire to a wall mount.	N2MV-WM1
• Ballast-Gard™ starter cut-out switch. Prevents starter pulsing when lamp is cycling or inoperative; prolongs ballast and ignitor life. Available for use with 50–150 watt – HPS	BG
• Factory Assembled. For a factory assembled luminaire with lamp installed.....	FA
• Instant Restrike. Enables a hot HPS lamp to immediately restrike after a momentary loss of arc due to voltage fluctuation or power outage. It has no effect on the warm-up period of cold lamps. 50–150W LX HPS only..... 50–100W LX HPS only.....	IR TIR
• Quartz Auxiliary Lighting. Comes to full brightness immediately and remains lit until the HID lamp attains 60–70% of full illumination. For non-hazardous locations only. (Note: QTZ lamp not included; use 100W single ended lamp – Q100DC, Q100CL/DC, or 100Q/CL/DC) Consult factory for top-hat limitations	QTZ
• Fused. To protect ballast and capacitor against abnormal line conditions	S658
• Furnished with Lamps	S714
• Teflon® Coated Globe. For additional protection against breakage. For use with 50–100W HPS, 70–175W MH and pulse start MH.....	S808

Accessories:

- See pages 1022–1023 for complete listing.



3L N2MV Series 50–150W High Pressure Sodium

Non-metallic
Champ® H.I.D. Luminaires

Cl. I, Div. 2, Groups A, B, C, D
Cl. II, Groups F, G
Cl. III & Simultaneous
Presence (100W max)

Marine & Wet Locations
3, 3R, 4, 4X; IP56

To complete the catalog #, include information in notes 1, 2 and 3 below. For guards and other optics see N2MV Series - Ordering By Components page.

Mounting Style	Hub Size	Lamp Watts	BASIC CATALOG NUMBER	
			With G303 Globe and P33 Guard	With GR305 Glass Refractor *
Pendant Mount	3/4	50	N2MVS2A050GP	N2MVS2A050GR305
	1		N2MVS3A050GP	N2MVS3A050GR305
	3/4	70	N2MVS2A070GP	N2MVS2A070GR305
	1		N2MVS3A070GP	N2MVS3A070GR305
	3/4	100	N2MVS2A100GP	N2MVS2A100GR305
	1		N2MVS3A100GP	N2MVS3A100GR305
	3/4	150	N2MVS2A150GP	N2MVS2A150GR305
	1		N2MVS3A150GP	N2MVS3A150GR305
Ceiling Mount Thru-Feed	3/4	50	N2MVS2C050GP	N2MVS2C050GR305
	1		N2MVS3C050GP	N2MVS3C050GR305
	3/4	70	N2MVS2C070GP	N2MVS2C070GR305
	1		N2MVS3C070GP	N2MVS3C070GR305
	3/4	100	N2MVS2C100GP	N2MVS2C100GR305
	1		N2MVS3C100GP	N2MVS3C100GR305
	3/4	150	N2MVS2C150GP	N2MVS2C150GR305
	1		N2MVS3C150GP	N2MVS3C150GR305
Stanchion Mount 25° Angle	1 1/2	50	N2MVSJ050GP	N2MVSJ050GR305
	1 1/2	70	N2MVSJ070GP	N2MVSJ070GR305
	1 1/2	100	N2MVSJ100GP	N2MVSJ100GR305
	1 1/2	150	N2MVSJ150GP	N2MVSJ150GR305

* For GR302 Type II Refractor, change "GR305" at end of catalog number to "GR302". Ex. N2MVS2A050GR302
For GR303 Type III Refractor, change "GR305" at end of catalog number to "GR303". Ex. N2MVS2A050GR303

1. Add voltage suffix to end of catalog number
Standard Voltage Ballasts - 60Hz

Voltage Suffix	NEC/UL				CEC/CSA (cUL)			
	Multi Tap /MT	Dual Tap /DT	120V /120	480V /480	Tri Tap /TT	Dual Tap /DT	120V /120	
Optional Voltage Ballasts - 50 or 60Hz								
Voltage Suffix	CEC/CSA (cUL) - CWI Isolated Ballasts				EXPORT			
	208V CWI /208CWI	240V CWI /240CWI	480V CWI /480CWI	600V CWI /600CWI	220V 60Hz /220	220V 50Hz /220 50	230V 50Hz /230 50	240V 50Hz /240 50

2. 150W HPS Luminaires: For 55V lamps - add suffix LX; for 100V lamps - add suffix CE. 50W HPS luminaire is dual tap only.
3. Options - Add the required option suffixes, see page 1005, in alpha-numeric order.

3L

N2MV Series 150–175W Pulse Start Metal Halide

Non-metallic Champ® H.I.D. Luminaires

Cl. I, Div. 2, Groups A, B, C, D Marine & Wet Locations
Cl. II, Groups F, G 3, 3R, 4, 4X; IP56
Cl. III & Simultaneous
Presence (100W max)

3L

To complete the catalog #, include information in notes 1 and 2 below. For guards and other optics see N2MV Series - Ordering By Components page.

Mounting Style	Hub Size	Lamp Watts	BASIC CATALOG NUMBER	
			With G303 Globe and P33 Guard *	With GR305–S828 Glass Refractor
Pendant Mount	3/4	150	N2MVM2A150GP S828	N2MVM2A150GR305 S828
	1		N2MVM3A150GP S828	N2MVM3A150GR305 S828
	3/4	175	N2MVM2A175GP S828	N2MVM2A175GR305 S828
	1		N2MVM3A175GP S828	N2MVM3A175GR305 S828
Ceiling Mount Thru-Feed	3/4	150	N2MVM2C150GP S828	N2MVM2C150GR305 S828
	1		N2MVM3C150GP S828	N2MVM3C150GR305 S828
	3/4	175	N2MVM2C175GP S828	N2MVM2C175GR305 S828
	1		N2MVM3C175GP S828	N2MVM3C175GR305 S828
Stanchion Mount 25° Angle	1 1/2	150	N2MVMJ150GP S828	N2MVMJ150GR305 S828
	1 1/2	175	N2MVMJ175GP S828	N2MVMJ175GR305 S828

* For GR302 Type II Refractor, change "GR305" at end of catalog number to "GR302". Ex. N2MVM2A150GR302-S828
For GR303 Type III Refractor, change "GR305" at end of catalog number to "GR303". Ex. N2MVM2A150GR303-S828

1. Add voltage suffix to end of catalog number

Standard Voltage Ballasts – 60Hz

Voltage Suffix	Multi Tap /MT	NEC/UL		CEC/CSA (cUL)	
		120V /120	480V /480	Tri Tap /TT	120V /120
Optional Voltage Ballasts - 50 or 60Hz					

EXPORT

Voltage Suffix	220V 60Hz /220	220V 50Hz /220 50	230V 50Hz /230 50	240V 50Hz /240 50

2. Options - Add the required option suffixes, see page 1005, in alpha-numeric order.



3L N2MV Series 70–175W Metal Halide

**Non-metallic
Champ® H.I.D. Luminaires**

Cl. I, Div. 2, Groups A, B, C, D
Cl. II, Groups F, G
Cl. III & Simultaneous
Presence (100W max)

Marine & Wet Locations
3, 3R, 4, 4X; IP56

To complete the catalog #, include information in notes 1, 2 and 3 below. For guards and other optics see N2MV Series - Ordering By Components page.

Mounting Style	Hub Size	Lamp Watts	BASIC CATALOG NUMBER	
			With G303 Globe and P33 Guard	With GR305 Glass Refractor *
Pendant Mount	3/4	70	N2MVM2A070GP	N2MVM2A070GR305
	1		N2MVM3A070GP	N2MVM3A070GR305
	3/4	100	N2MVM2A100GP	N2MVM2A100GR305
	1		N2MVM3A100GP	N2MVM3A100GR305
	3/4	175	N2MVM2A175GP	N2MVM2A175GR305
	1		N2MVM3A175GP	N2MVM3A175GR305
Ceiling Mount Thru-Feed	3/4	70	N2MVM2C070GP	N2MVM2C070GR305
	1		N2MVM3C070GP	N2MVM3C070GR305
	3/4	100	N2MVM2C100GP	N2MVM2C100GR305
	1		N2MVM3C100GP	N2MVM3C100GR305
	3/4	175	N2MVM2C175GP	N2MVM2C175GR305
	1		N2MVM3C175GP	N2MVM3C175GR305
Stanchion Mount 25° Angle	1 1/2	70	N2MVMJ070GP	N2MVMJ070GR305
	1 1/2	100	N2MVMJ100GP	N2MVMJ100GR305
	1 1/2	175	N2MVMJ175GP	N2MVMJ175GR305

* For GR302 Type II Refractor, change "GR305" at end of catalog number to "GR302". Ex. N2MVM2A070GR302
For GR303 Type III Refractor, change "GR305" at end of catalog number to "GR303". Ex. N2MVM2A070GR303

1. Add voltage suffix to end of catalog number

Standard Voltage Ballasts - 60Hz

Voltage Suffix	Multi Tap /MT	NEC/UL		CEC/CSA (cUL)	
		120V /120	480V /480	Tri Tap /TT	120V /120

Optional Voltage Ballasts - 50 or 60Hz

Voltage Suffix	CEC/CSA (cUL) - CWI Isolated Ballasts			EXPORT			
	208V CWI /208CWI	240V CWI /240CWI	600V CWI /600CWI	220V 60Hz /220	220V 50Hz /220 50	230V 50Hz /230 50	240V 50Hz /240 50

2. 70W ballast not available in 480V.

3. Options - Add the required option suffixes, see page 1005, in alpha-numeric order.

3L

N2MV Series – Ordering by Components

N2MV luminaires are available in components.

A complete luminaire consists of:

- I. N2MV Cover (Mounting Module)
- II. N2MV Ballast Housing – Include voltage and required option(s)
- III. Globe, Refractor, Guard, Reflector

I. N2MV Cover (Mounting Module):

Type	Conduit	Cat. #
Pendant	3/4"	N2APM2
	1"	N2APM3
Ceiling	3/4"	N2CM2
	1"	N2CM3
Wall (Use wall bracket accessory with Ceiling Cover)	3/4"	N2MV WM1 and N2CM2
	1"	N2MV WM1 and N2CM3
Stanchion – 25 Degree Angle	1 1/2"	N2JM5

II. Ballast Housings:

Complete catalog number must have the **voltage suffix** (MT shown) and any **options suffixes**.

Lamp Type	Lamp Watts	Cat. #
High Pressure Sodium	50	N2MVS050/MT
	70	N2MVS070/MT
	100	N2MVS100/MT
	150	N2MVS150/MT LX
Metal Halide	70	N2MVM070/MT
	100	N2MVM100/MT
	175	N2MVM175/MT

III. Globe, Refractors, Guards and Reflectors:

Type	Cat. #
Globe	G303
Globe Teflon Coated	G303S808
Globe Guard	P33
Reflector – Dome	RD739
Reflector – Angle	RA739
Refractor – Type 2	GR302
Refractor – Type 3	GR303
Refractor – Type 5	GR305
Refractor Guard	P23
Large Plastic Refractor Type 2	PGR302
Large Plastic Refractor Type 3	PGR303
Large Plastic Refractor Type 5	PGR305



Champ® H.I.D Luminaires

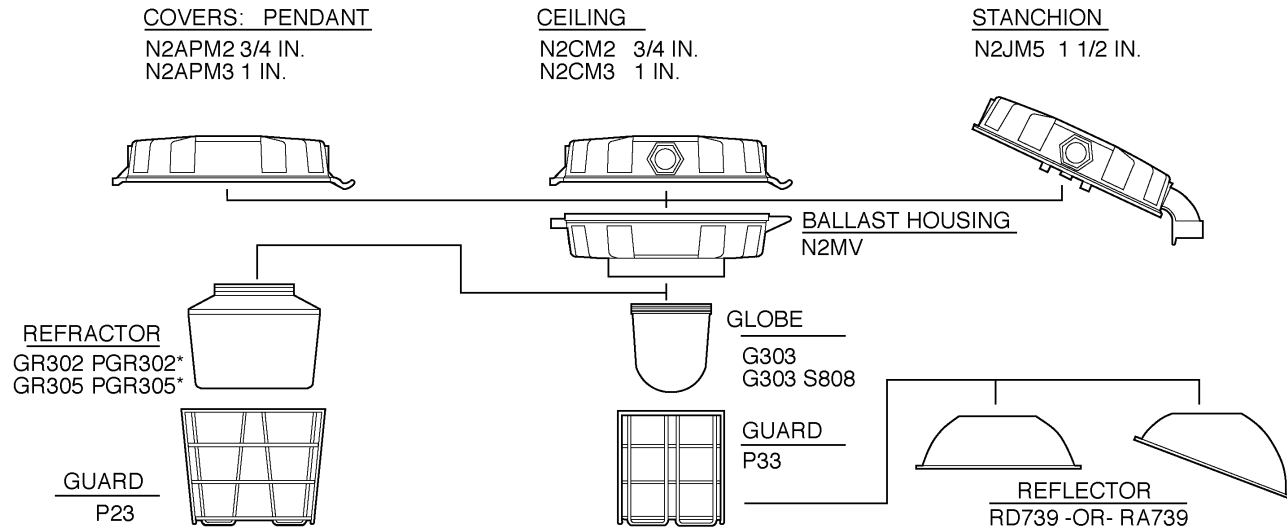

*Plastic refractors are non-hazardous areas only (50-100W Max.)

3L

Champ® H.I.D Luminaires

Lamp Watts	Ambient Temp C	Optics	Class I (Gas/Vapors)	Class II (Dust) and Class III	Simultaneous Presence Gas and Dust Present in the Same Area	Supply Wire Temp C
			Non Restricted Breathing		Non Restricted Breathing	
			Standard Product	Standard Product	Standard Product	
			Division 2		Class I, Division 2 and Class II	
		G303	X	X	X	
		GR305	X	X	X	

High Pressure Sodium

50	40	T3A	T4A	T2C/T4A	75
	55	T3A	-	-	85
	65	-	-	-	-
70	40	T3A	T4A	T2C/T4A	75
	55	T3A	-	-	85
	65	-	-	-	-
100	40	T2D	T4A	T2C/T4A	85
	55	T2C	-	-	100
	65	-	-	-	-
150	40	T2C	-	-	85
	55	-	-	-	-
	65	-	-	-	-

Metal Halide

70	40	T3C	T4	T2B/T4	75
	55	T3B	-	-	85
	65	-	-	-	-
100	40	T2B	T4	T2B/T4	85
	55	T2B	-	-	-
	65	-	-	-	-
150 (S828)	40	T2	-	-	-
	55	-	-	-	-
	65	-	-	-	-
175 (Includes S828)	40	T2	-	-	-
	55	-	-	-	-
	65	-	-	-	-



Champ® H.I.D. Luminaires

Dimensions
In Inches:

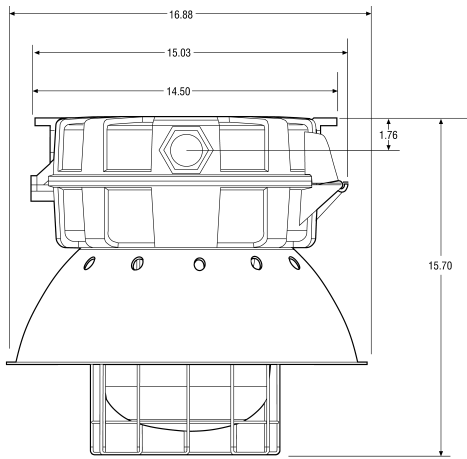

Ceiling Mount

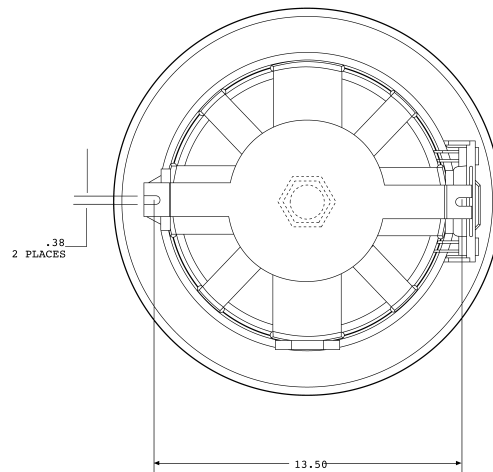

Ceiling Mount - Top View

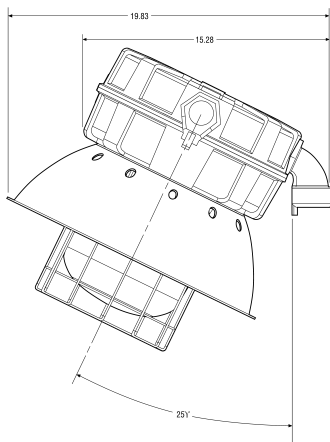

25° Angle Stanchion Mount

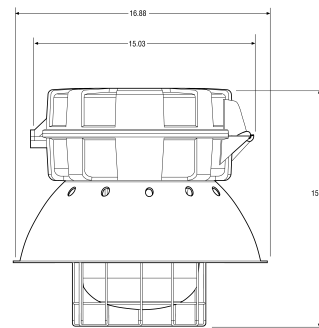

Pendant Mount

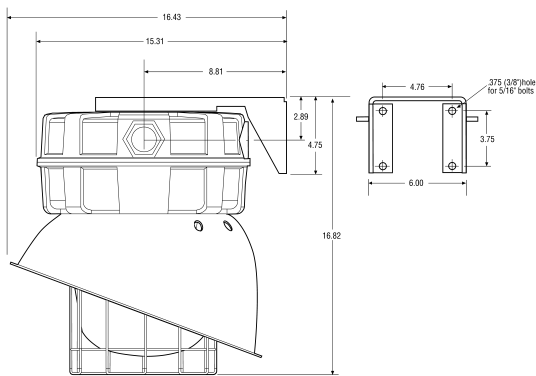

Wall Arm Mount

Net Luminaire Weights (lbs.):

Luminaire Series	Lamp Watts	Luminaire with Globe, Guard (lbs.)	Lamp Watts	Luminaire with Globe, Guard (lbs.)
N2VMS	50	23	70	23 ¹ / ₁₆
	100	24 ¹ / ₁₆	150	26 ¹ / ₈
N2MVM	70	21	100	21 ¹ / ₁₆
	175	22 ¹ / ₄	250	24

Type	Lbs.	Type	Lbs.
Add for mounting modules:			
Pendant	1 ¹ / ₄	Flexible Pendant	1 ¹ / ₂
Ceiling	2 ³ / ₄	Wall	4 ¹ / ₂
Quad-Mount	3 ¹ / ₂	Angle Stanchion	3 ¹ / ₂
Straight Stanchion	4 ¹ / ₂		

Add for reflectors:
 Dome 1¹/₄ 30° Angle 1¹/₄
Deduct: 1 lb. for luminaire without P33 Guard.
Add: 5¹/₂ lbs. for luminaire with GR305 refractor.

3L

Champ® H.I.D Luminaires

Lamp: 150W/E-23-1/2 clear high pressure sodium (HPS)
 Total bare lamp lumens: 16000

All data provided is for high pressure sodium luminaires with 150W/E-23-1/2 clear lamps. Use conversion factors (multipliers) shown below for other clear lamp types and wattages. Consult Eaton's Crouse-Hinds for additional photometric data on any Champ series luminaires.

Luminaire with Globe and Dome Reflector

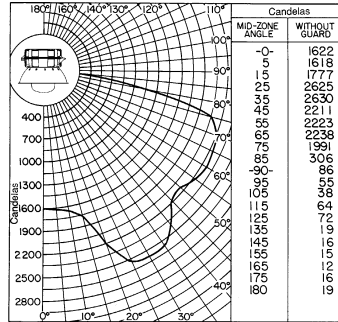

Multipliers (for use with candela curve only).

Luminaire Series	Lamp Watts	Conversion Factor
N2MVS	50	0.25
	70	0.40
	100	0.59

Luminaire spacing ratio: 1.90

Coefficient of Utilization

Effective Floor Cavity Reflectance 20%

% Reflectance Eff. Ceil.	Wall	Room Cavity Ratio				
		1	2	3	4	5
80	50	.759	.643	.551	.476	.418
	30	.719	.582	.480	.400	.340
	10	.683	.530	.424	.342	.283
70	50	.740	.627	.538	.465	.406
	30	.703	.570	.471	.394	.334
	10	.669	.523	.418	.338	.280
50	50	.703	.595	.512	.442	.388
	30	.672	.548	.455	.381	.324
	10	.645	.506	.408	.332	.276
30	50	.669	.567	.488	.422	.370
	30	.646	.528	.439	.368	.314
	10	.622	.492	.399	.325	.270
10	50	.640	.541	.466	.403	.354
	30	.619	.508	.424	.356	.305
	10	.600	.479	.389	.318	.265
0	0	.582	.459	.370	.299	.247
% Reflectance Eff. Ceil.	Wall	Room Cavity Ratio				
		6	7	8	9	10
80	50	.371	.330	.294	.267	.231
	30	.296	.257	.224	.198	.164
	10	.243	.208	.174	.151	.121
70	50	.362	.323	.288	.262	.226
	30	.291	.252	.221	.195	.164
	10	.238	.204	.173	.151	.121
50	50	.345	.309	.275	.250	.218
	30	.283	.244	.215	.190	.159
	10	.235	.201	.170	.148	.119
30	50	.331	.294	.265	.240	.209
	30	.275	.239	.208	.184	.154
	10	.231	.196	.168	.146	.116
10	50	.317	.284	.253	.231	.201
	30	.266	.233	.203	.180	.150
	10	.227	.193	.165	.143	.114
0	0	.210	.177	.149	.128	.100

Isofootcandle Chart: Luminaire with Globe and Dome Reflector

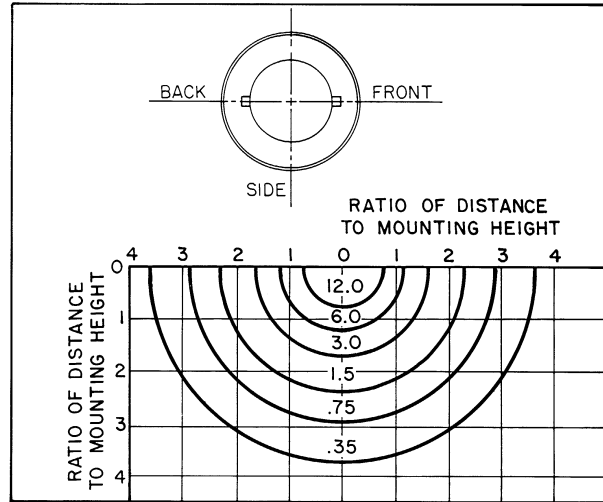

Isofootcandle Chart: Luminaire with Globe and 30° Angle Reflector

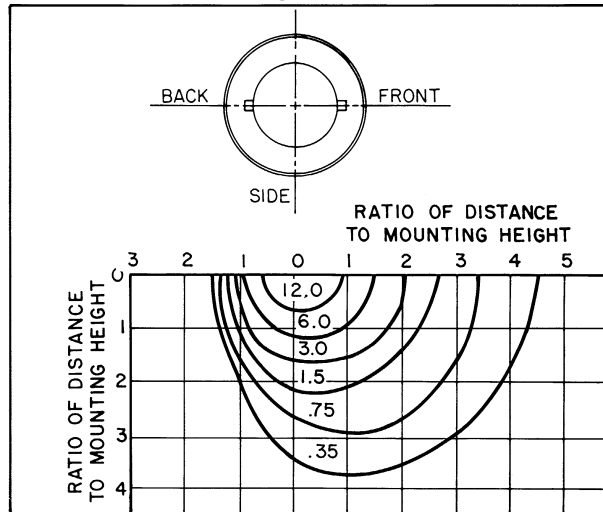

Isofootcandle charts show illumination in footcandles on work plane 10 feet below light center. Multiply by factor shown to convert to other mounting heights.

Height (Ft.)	Factor	Height (Ft.)	Factor
8	1.56	16	.391
12	.694	20	.250
14	.510		



NVMV Series 70-400W Ex-Protected Luminaire for IEC and ATEX Applications

Champ® H.I.D. Luminaires

Ex nR II T...Gc
 Ex t IIIC T...°C Db IP66
 LCIE 09 ATEX 1002
 LCIE 09 ATEX 3008

The Champ® NVMV design is optimized for Zone 2 gas applications (with standard restricted breathing Ex nR protection), as well as Zone 21 dust applications.

Applications:

NVMV Ex-Protected Luminaires are suitable for applications in Zone 2/Zone 21/Zone 22:

- In manufacturing plants, refineries, chemical, petrochemical, and other industrial process facilities, waste or sewage treatment facilities, dockside and other heavy industrial applications
- In areas where combustible dusts or fibers may be present
- In areas where ignitable concentrations of flammable gases or vapors will be present
- In installations where moisture, dirt, dust, vibration, corrosion, and rough usage are problematic

Features:

- One product offering for global applications. The Champ family has the required IEC and ATEX certifications to provide solutions for specification requirements around the world.
- Restricted breathing (Ex nR) protection is standard. This provides better T-ratings, as gases will not enter the lamp chamber and control gear housing.
- Provides an integrated ballast with thermal cut-off functionality incorporated into the control gear. In the event of abnormal temperatures or when the lamp approaches end of life, the cut-off functionality protects the ballast from overheating or burning out.
- Identical mounting cover for IEC and NEC applications - regardless of wattage, options, and accessories. Reduce inventory costs and provide greater flexibility for engineering designers, customers, and distributors.
- HPS lamps restrike in 10-30 seconds with the instant restrike option (IR) should lamp extinguish due to system voltage drop or momentary loss. Optional built-in cut-off feature will shut off the instant restrike to avoid continuous high energy pulsing when lamp is inoperative or nearing end of life.
- Available with the Champ Quick-Clip. Quick-Clip secures the housing to the cover, providing faster, easier, and safer luminaire installation.

Certifications and Compliances:

Application in Zone 2 area acc. IEC 60079-15

- Marking to 94/9/EC: Ex II 3 G Ex nR II T...Gc
- EC - Type Examination: LCIE 09 ATEX 1002

Application in Zone 21 and 22 areas acc. IEC 61241-1

- Marking to 94/9/EC: Ex II 2 D Ex t IIIC T...°C(*) Db IP66
- EC - Type Examination: LCIE 09 ATEX 3008

General per both application Zone 2 and 21

- Temperature ambient of use: -45°C to +55°C
- Electromagnetic compatibility: EN 61000-6-4
- Degree of protection: acc. EN 60529 IP66

Standard Materials and Finishes:

- Ballast housing and mountings - copper-free aluminum
- Exterior hardware - stainless steel (type 304)
- Reflectors (dome and angle) - Krydon® fiberglass-reinforced polyester
- Globes - heat and impact-resistant glass
- Guards - copper-free aluminum and stainless steel (large housing - stainless steel only)

Technical Specifications:

- | | |
|----------------------|---|
| • Entry | Up to 4 x M20, M25, M32, 1/2" NPT and 3/4" NPT and 1" NPT cable entries (1 1/2" NPT for stanchion only) |
| • Termination | 3 Core 6mm ² max. (standard); 6 x 6mm ² for looping (available upon request) |
| • Installation | Ceiling Mount, Wall Mount, Stanchion Mount, Pendant Mount |
| • Lamp Holder | E27 or E40 |
| • Lamp Type | HSE/HST (high pressure sodium lamp) and HIE (metal halide lamp) |
| • Lamp Power | 70W, 100W, 150W, 250W, and 400W |
| • Control Gear | Integrated ballast, thermal cut-off functionality incorporated into control gear |
| • Re-lamping | Access via restricted breathing lamp chamber |
| • Burning Position | Base up; up to 25° off vertical |
| • Ingress Protection | IP66 to EN 60529 |
| • Electrical Supply | 220, 230, 240V 50Hz and 220, 230V 60Hz |



NVMV 70W - 250W (Small Housing)



NVMV 250W - 400W (Large Housing)

NVMV Series 70-400W Ex-Protected Luminaire for IEC and ATEX Applications

Ex nR II T...Gc
 Ex t IIIC T...°C Db IP66
 LCIE 09 ATEX 1002
 LCIE 09 ATEX 3008

3L

Champ® H.I.D. Luminaires

Ordering Information:

Ordering Example: to complete part number, select ordering options from tables below and display them in the following order.

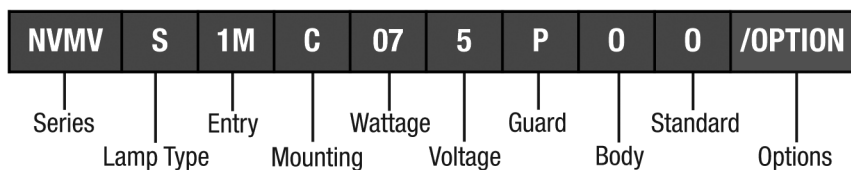

Example of Completed Part Number - Small Body: NVMVS1MC075POO

NVMV	S	1M	C	07	5	P	O	O
Series	Lamp	Entry	Mounting*	Wattage	Voltage	Guard	Body	
NVMV Luminaire IEC Gear	S = HSE/HST (HPS) M = HIE (MH)	1M = M20 2M = M25 3M = M32 1N = 1/2" NPT 2N = 3/4" NPT 3N = 1" NPT 5N = 1 1/2" NPT (For Stanchion)	C = Ceiling W = Wall J = Stanchion	07 = 70W 10 = 100W 15 = 150W 25 = 250W	3 = 220V / 50 Hz 5 = 230V / 50 Hz 6 = 240V / 50 Hz 4 = 220V / 60 Hz 7 = 230V / 60 Hz	O = Without Guard G34 Globe P = G251 Globe with P22 Alum. Guard S = G251 Globe with P22 SS304 Guard	O = Small Body	O = Standard

Example of Completed Part Number - Large Body: NVMVS1MC255PLO

NVMV	S	1M	C	25	5	P	L	O
Series	Lamp	Entry	Mounting*	Wattage	Voltage	Guard	Body	
NVMV Luminaire IEC Gear	S = HSE/HST (HPS) M = HIE (MH)	1M = M20 2M = M25 3M = M32 1N = 1/2" NPT 2N = 3/4" NPT 3N = 1" NPT 5N = 1 1/2" NPT (For Stanchion)	C = Ceiling W = Wall J = Stanchion	25 = 250W 40 = 400W	3 = 220V / 50 Hz 5 = 230V / 50 Hz 6 = 240V / 50 Hz 4 = 220V / 60 Hz 7 = 230V / 60 Hz	O = Without Guard G303 Globe P = G303 Globe with P33 SS Guard	L = Large Body	O = Standard

Options and Accessories:

Description	Suffix
Instant restrike (100W HPS and 150W HPS) (alternative solution to dual arc lamps)	/IR
Dome reflector - small housing	/RD70
30° angle reflector - small housing	/RA70
Dome reflector - large housing	/RD739
30° angle reflector - large housing	/RA739
Champ® Quick-Clip	/S890

*For pendant mounting, order ceiling mount with pendant bracket accessory - please consult factory.



Champ® H.I.D. Luminaires

Temperature Performance:

Refer to temperature performance data tables (below) to select luminaire that is suitable for your area specifications. These numbers are the maximum surface temperature of the luminaire.

Note: T3 - maximum surface temperature 200°C
T4 - maximum surface temperature 135°C

For example: atmospheres that contain gasoline and have an ignition temperature of 536°C, any fixture with the T-rating in this table can be used.

Atmospheres that contain diethyl ether and have an ignition temperature of 160°C require a luminaire with T4 ratings.

NVMV 70W - 250W (Small Housing)

Catalog Number Example†	Watts	Lamp Type	Rated Ambient °C	Lamp Holder	GAS (Class I, Zone 2) Ex nR II T...Gc				DUST (Class II, Zone 21) Ex t IIIC T...Db			
					With G34 Globe Only	With G251 Globe Only	With G34 Globe and Reflector	With G251 Globe and Reflector	With G34 Globe Only	With G251 Globe Only	With G34 Globe and Reflector	With G251 Globe and Reflector
NVMVS1MC075*00	70W	HSE/HST (HPS)	40	E27	T4	T4	T4	T4	99°C	109°C	104°C	109°C
			50		T4	T4	T4	T4	109°C	119°C	114°C	119°C
			55		T4	T4	T4	T4	114°C	124°C	119°C	124°C
NVMVS1MC105*00	100W		40	E40	T4	T4	T4	T4	99°C	117°C	104°C	128°C
			50		T4	T4	T4	T3	109°C	127°C	114°C	138°C
			55		T4	T3	T4	T3	114°C	132°C	119°C	143°C
NVMVS1MC155*00	150W		40	E40	T4	T3	T3	T3	122°C	140°C	140°C	140°C
			50		T3	T3	T3	T3	132°C	150°C	150°C	150°C
			55		T3	T3	T3	T3	137°C	155°C	155°C	155°C
NVMVS1MC255*00	250W		40	E40	T3	T3	T3	T2	168°C	174°C	189°C	218°C
			50		T3	T3	T2	T2	178°C	184°C	199°C	228°C
			55		T3	T3	T2	T2	183°C	189°C	204°C	233°C
NVMVM1MC075*00	70W	HIE (MH)	40	E27	T4	T4	T4	T4	99°C	109°C	104°C	109°C
			50		T4	T4	T4	T4	109°C	119°C	114°C	119°C
			55		T4	T4	T4	T4	114°C	124°C	119°C	124°C
NVMVM1MC105*00	100W		40	E27	T4	T4	T4	T4	99°C	117°C	104°C	128°C
			50		T4	T4	T4	T3	109°C	127°C	114°C	138°C
			55		T4	T3	T4	T3	114°C	132°C	119°C	143°C
NVMVM1MC155*00	150W		40	E27	T4	T3	T3	T3	122°C	140°C	140°C	140°C
			50		T3	T3	T3	T3	132°C	150°C	150°C	150°C
			55		T3	T3	T3	T3	137°C	155°C	155°C	155°C
NVMVM1MC255*00	250W		40	E40	T3	T3	T3	T2	168°C	194°C	189°C	218°C
			50		T3	T2	T2	T2	178°C	204°C	199°C	228°C
			55		T3	T2	T2	T2	183°C	209°C	204°C	233°C

†Cat. No. - shown with M20 Ceiling Mount, /230V, 50 Hz.

NVMV 250W - 400W (Large Housing)

Catalog Number Example	Watts	Lamp Type	Rated Ambient °C	Lamp Holder	GAS (Class I, Zone 2) Ex nR II T...Gc		DUST (Class II, Zone 21) Ex t IIIC T...Db	
					With G303 Globe Only	With G303 Globe and Reflector	With G303 Globe Only	With G303 Globe and Reflector
NVMVS1MC255*L0	250W	HSE/HST (HPS)	40	E40	T3	T3	137°C	137°C
			50		T3	T3	147°C	147°C
			55		T3	T3	152°C	152°C
NVMVS1MC405*L0	400W		40	E40	T3	T3	159°C	175°C
			50		T3	T3	169°C	185°C
			55		T3	T3	174°C	190°C
NVMVM1MC255*L0	250W	HIE (MH)	40	E40	T3	T3	137°C	137°C
			50		T3	T3	147°C	147°C
			55		T3	T3	152°C	152°C
NVMVM1MC405*L0	400W		40	E40	T3	T3	159°C	193°C
			50		T3	T2	169°C	203°C
			55		T3	T2	174°C	208°C

Champ® H.I.D. Luminaires

Dimensions:

NVMV 70W - 250W			
Pendant (7.7kg)	Ceiling (7.6kg)	Wall (8.0kg)	Stanchion (8.0kg)

NVMV 250W - 400W			
Pendant (21.1kg)	Ceiling (21.0kg)	Wall (21.4kg)	Stanchion (21.4kg)

REFLECTOR DIMENSIONS		
RD70 (for 70W - 250W)	RD739 (for 250W - 400W)	RA70 and RA739 (Small & Large Housing)
<p>(0.60kg)</p>	<p>(0.56kg)</p>	<p>(RA70 - 0.60kg; RA739 - 0.79kg)</p>



Champ® H.I.D. Luminaires

Photometry - Large Housing:

NVMV 400 WATT HSE - GLOBE AND GUARD ONLY		LAMP: 400W HSE										LIGHT OUTPUT UP: 21.9% LIGHT OUTPUT DOWN: 44.2%						
<p>LUMINOUS INTENSITY DISTRIBUTION DIAGRAM</p>		Ceiling	80%			70%			50%			30%			10%			0
		Wall	50%	30%	10%	50%	30%	10%	50%	30%	10%	50%	30%	10%	50%	30%	10%	0
		Floor	20%			20%			20%			20%			20%			0
		RCR	RCR: Room Cavity Ratio										Coefficients of Utilization (CU)					
		0	0.77	0.77	0.77	0.73	0.73	0.73	0.65	0.65	0.65	0.58	0.58	0.58	0.51	0.51	0.51	0.48
		1	0.61	0.56	0.52	0.57	0.53	0.49	0.50	0.47	0.44	0.44	0.41	0.39	0.38	0.36	0.34	0.31
		2	0.51	0.44	0.39	0.47	0.42	0.37	0.41	0.37	0.33	0.36	0.32	0.29	0.31	0.28	0.25	0.22
		3	0.43	0.36	0.31	0.40	0.34	0.29	0.35	0.30	0.26	0.30	0.26	0.23	0.26	0.22	0.20	0.17
		4	0.37	0.30	0.25	0.35	0.28	0.23	0.30	0.25	0.21	0.26	0.22	0.18	0.22	0.19	0.16	0.13
		5	0.33	0.25	0.20	0.30	0.24	0.19	0.27	0.21	0.17	0.23	0.18	0.15	0.20	0.16	0.13	0.11
6	0.29	0.22	0.17	0.27	0.21	0.16	0.24	0.18	0.14	0.20	0.16	0.13	0.17	0.14	0.11	0.09		
7	0.26	0.19	0.15	0.24	0.18	0.14	0.21	0.16	0.12	0.18	0.14	0.11	0.16	0.12	0.09	0.07		
8	0.23	0.17	0.13	0.22	0.16	0.12	0.19	0.14	0.11	0.17	0.12	0.09	0.14	0.11	0.08	0.06		
9	0.21	0.15	0.11	0.20	0.14	0.10	0.17	0.13	0.09	0.15	0.11	0.08	0.13	0.10	0.07	0.05		
10	0.19	0.14	0.10	0.18	0.13	0.09	0.16	0.11	0.08	0.14	0.10	0.07	0.12	0.09	0.06	0.05		

NVMV 400 WATT HSE - GLOBE AND DOME REFLECTOR		LAMP: 400W HSE										LIGHT OUTPUT UP: 1.6% LIGHT OUTPUT DOWN: 44.0%						
<p>LUMINOUS INTENSITY DISTRIBUTION DIAGRAM</p>		Ceiling	80%			70%			50%			30%			10%			0
		Wall	50%	30%	10%	50%	30%	10%	50%	30%	10%	50%	30%	10%	50%	30%	10%	0
		Floor	20%			20%			20%			20%			20%			0
		RCR	RCR: Room Cavity Ratio										Coefficients of Utilization (CU)					
		0	0.60	0.60	0.60	0.59	0.59	0.59	0.56	0.56	0.56	0.53	0.53	0.53	0.50	0.50	0.50	0.49
		1	0.50	0.47	0.45	0.49	0.46	0.44	0.46	0.44	0.42	0.44	0.42	0.41	0.42	0.40	0.39	0.38
		2	0.42	0.38	0.34	0.41	0.37	0.34	0.39	0.36	0.33	0.37	0.34	0.32	0.35	0.33	0.31	0.29
		3	0.36	0.31	0.27	0.35	0.31	0.27	0.33	0.29	0.26	0.32	0.28	0.25	0.30	0.27	0.25	0.23
		4	0.31	0.26	0.22	0.31	0.26	0.22	0.29	0.25	0.21	0.27	0.24	0.21	0.26	0.23	0.20	0.19
		5	0.28	0.22	0.18	0.27	0.22	0.18	0.25	0.21	0.18	0.24	0.20	0.17	0.23	0.20	0.17	0.16
6	0.24	0.19	0.16	0.24	0.19	0.15	0.23	0.18	0.15	0.22	0.18	0.15	0.21	0.17	0.15	0.13		
7	0.22	0.17	0.13	0.21	0.17	0.13	0.20	0.16	0.13	0.19	0.16	0.13	0.19	0.15	0.13	0.11		
8	0.20	0.15	0.12	0.19	0.15	0.12	0.18	0.14	0.11	0.18	0.14	0.11	0.17	0.13	0.11	0.10		
9	0.18	0.13	0.10	0.18	0.13	0.10	0.17	0.13	0.10	0.16	0.12	0.10	0.15	0.12	0.10	0.09		
10	0.16	0.12	0.09	0.16	0.12	0.09	0.15	0.12	0.09	0.15	0.11	0.09	0.14	0.11	0.09	0.08		

NVMV 400 WATT HSE - GLOBE AND 30° ANGLE REFLECTOR		LAMP: 400W HSE										LIGHT OUTPUT UP: 4.6% LIGHT OUTPUT DOWN: 39.5%						
<p>LUMINOUS INTENSITY DISTRIBUTION DIAGRAM</p>		Ceiling	80%			70%			50%			30%			10%			0
		Wall	50%	30%	10%	50%	30%	10%	50%	30%	10%	50%	30%	10%	50%	30%	10%	0
		Floor	20%			20%			20%			20%			20%			0
		RCR	RCR: Room Cavity Ratio										Coefficients of Utilization (CU)					
		0	0.60	0.60	0.60	0.58	0.58	0.58	0.54	0.54	0.54	0.51	0.51	0.51	0.47	0.47	0.47	0.46
		1	0.49	0.46	0.44	0.47	0.45	0.42	0.44	0.42	0.40	0.41	0.40	0.38	0.39	0.37	0.36	0.34
		2	0.42	0.37	0.34	0.40	0.36	0.33	0.37	0.34	0.31	0.35	0.32	0.30	0.33	0.30	0.28	0.27
		3	0.36	0.31	0.27	0.35	0.30	0.26	0.32	0.28	0.25	0.30	0.27	0.24	0.28	0.25	0.23	0.22
		4	0.31	0.26	0.22	0.30	0.25	0.22	0.28	0.24	0.21	0.26	0.23	0.20	0.25	0.22	0.19	0.18
		5	0.28	0.22	0.19	0.27	0.22	0.18	0.25	0.21	0.18	0.23	0.20	0.17	0.22	0.19	0.16	0.15
6	0.25	0.19	0.16	0.24	0.19	0.16	0.22	0.18	0.15	0.21	0.17	0.14	0.20	0.16	0.14	0.13		
7	0.22	0.17	0.14	0.21	0.17	0.13	0.20	0.16	0.13	0.19	0.15	0.13	0.18	0.15	0.12	0.11		
8	0.20	0.15	0.12	0.19	0.15	0.12	0.18	0.14	0.11	0.17	0.14	0.11	0.16	0.13	0.11	0.10		
9	0.18	0.14	0.11	0.18	0.13	0.10	0.17	0.13	0.10	0.16	0.12	0.10	0.15	0.12	0.09	0.08		
10	0.17	0.12	0.10	0.16	0.12	0.09	0.15	0.12	0.09	0.14	0.11	0.09	0.14	0.11	0.09	0.08		

3L

Champ® H.I.D. Luminaires

Photometry - Large Housing:

NVMV 250 WATT HSE - GLOBE AND GUARD ONLY		LAMP: 250W HSE						LIGHT OUTPUT UP: 21.9% LIGHT OUTPUT DOWN: 44.2%										
<p>LUMINOUS INTENSITY DISTRIBUTION DIAGRAM</p> <p>UNIT: cd/klm — C0 /180 — C90 /270</p>		Ceiling	80%		70%		50%		30%		10%		0					
		Wall	50%	30%	10%	50%	30%	10%	50%	30%	10%	50%	30%	10%	0			
		Floor	20%		20%		20%		20%		20%		20%		0			
		RCR	RCR: Room Cavity Ratio						Coefficients of Utilization (CU)									
		0	0.75	0.75	0.75	0.70	0.70	0.70	0.60	0.60	0.60	0.52	0.52	0.52	0.44	0.44	0.44	0.40
		1	0.59	0.55	0.51	0.55	0.51	0.47	0.46	0.43	0.41	0.39	0.36	0.34	0.32	0.30	0.28	0.25
		2	0.49	0.43	0.38	0.45	0.40	0.35	0.38	0.34	0.30	0.32	0.28	0.25	0.26	0.23	0.21	0.17
		3	0.42	0.35	0.30	0.39	0.33	0.28	0.32	0.28	0.24	0.27	0.23	0.20	0.21	0.18	0.16	0.13
		4	0.36	0.29	0.24	0.33	0.27	0.22	0.28	0.23	0.19	0.23	0.19	0.16	0.18	0.15	0.12	0.10
		5	0.32	0.25	0.20	0.29	0.23	0.18	0.25	0.20	0.16	0.20	0.16	0.13	0.16	0.13	0.10	0.08
6	0.28	0.22	0.17	0.26	0.20	0.16	0.22	0.17	0.13	0.18	0.14	0.11	0.14	0.11	0.08	0.06		
7	0.25	0.19	0.14	0.23	0.17	0.13	0.20	0.15	0.11	0.16	0.12	0.09	0.13	0.10	0.07	0.05		
8	0.23	0.17	0.12	0.21	0.15	0.11	0.18	0.13	0.10	0.15	0.11	0.08	0.12	0.09	0.06	0.04		
9	0.21	0.15	0.11	0.19	0.14	0.10	0.16	0.12	0.08	0.13	0.10	0.07	0.11	0.08	0.05	0.04		
10	0.19	0.13	0.09	0.17	0.12	0.09	0.15	0.10	0.07	0.12	0.09	0.06	0.10	0.07	0.05	0.03		

NVMV 250 WATT HSE - GLOBE AND DOME REFLECTOR		LAMP: 250W HSE						LIGHT OUTPUT UP: 1.6% LIGHT OUTPUT DOWN: 44.0%										
<p>LUMINOUS INTENSITY DISTRIBUTION DIAGRAM</p> <p>UNIT: cd/klm — C0 /180 — C90 /270</p>		Ceiling	80%		70%		50%		30%		10%		0					
		Wall	50%	30%	10%	50%	30%	10%	50%	30%	10%	50%	30%	10%	0			
		Floor	20%		20%		20%		20%		20%		20%		0			
		RCR	RCR: Room Cavity Ratio						Coefficients of Utilization (CU)									
		0	0.64	0.64	0.64	0.62	0.62	0.62	0.59	0.59	0.59	0.56	0.56	0.56	0.53	0.53	0.53	0.52
		1	0.53	0.50	0.47	0.51	0.48	0.46	0.48	0.46	0.44	0.46	0.44	0.42	0.43	0.42	0.40	0.39
		2	0.44	0.40	0.36	0.43	0.39	0.35	0.41	0.37	0.34	0.38	0.35	0.33	0.36	0.34	0.32	0.30
		3	0.38	0.32	0.28	0.37	0.32	0.28	0.35	0.30	0.27	0.33	0.29	0.26	0.31	0.28	0.25	0.24
		4	0.33	0.27	0.23	0.32	0.27	0.23	0.30	0.26	0.22	0.28	0.25	0.21	0.27	0.24	0.21	0.19
		5	0.29	0.23	0.19	0.28	0.23	0.19	0.26	0.22	0.18	0.25	0.21	0.18	0.24	0.20	0.17	0.16
6	0.26	0.20	0.16	0.25	0.20	0.16	0.24	0.19	0.16	0.22	0.18	0.15	0.21	0.18	0.15	0.14		
7	0.23	0.18	0.14	0.22	0.17	0.14	0.21	0.17	0.14	0.20	0.16	0.13	0.19	0.16	0.13	0.12		
8	0.21	0.16	0.12	0.20	0.15	0.12	0.19	0.15	0.12	0.18	0.14	0.12	0.18	0.14	0.11	0.10		
9	0.19	0.14	0.11	0.18	0.14	0.11	0.18	0.13	0.10	0.17	0.13	0.10	0.16	0.13	0.10	0.09		
10	0.17	0.13	0.10	0.17	0.13	0.10	0.16	0.12	0.09	0.16	0.12	0.09	0.15	0.11	0.09	0.08		

NVMV 250 WATT HSE - GLOBE AND 30° ANGLE REFLECTOR		LAMP: 250W HSE						LIGHT OUTPUT UP: 4.6% LIGHT OUTPUT DOWN: 39.5%										
<p>LUMINOUS INTENSITY DISTRIBUTION DIAGRAM</p> <p>UNIT: cd/klm — C0 /180 — C90 /270</p>		Ceiling	80%		70%		50%		30%		10%		0					
		Wall	50%	30%	10%	50%	30%	10%	50%	30%	10%	50%	30%	10%	0			
		Floor	20%		20%		20%		20%		20%		20%		0			
		RCR	RCR: Room Cavity Ratio						Coefficients of Utilization (CU)									
		0	0.61	0.61	0.61	0.59	0.59	0.59	0.55	0.55	0.55	0.51	0.51	0.51	0.48	0.48	0.48	0.46
		1	0.50	0.47	0.44	0.48	0.45	0.43	0.45	0.42	0.40	0.41	0.40	0.38	0.39	0.37	0.36	0.34
		2	0.42	0.38	0.34	0.41	0.37	0.33	0.38	0.34	0.31	0.35	0.32	0.30	0.32	0.30	0.28	0.26
		3	0.36	0.31	0.27	0.35	0.30	0.26	0.32	0.28	0.25	0.30	0.27	0.24	0.28	0.25	0.23	0.21
		4	0.32	0.26	0.22	0.30	0.26	0.22	0.28	0.24	0.21	0.26	0.23	0.20	0.24	0.21	0.19	0.17
		5	0.28	0.23	0.19	0.27	0.22	0.18	0.25	0.21	0.18	0.23	0.20	0.17	0.22	0.19	0.16	0.15
6	0.25	0.20	0.16	0.24	0.19	0.16	0.22	0.18	0.15	0.21	0.17	0.14	0.19	0.16	0.14	0.12		
7	0.22	0.17	0.14	0.22	0.17	0.14	0.20	0.16	0.13	0.19	0.15	0.13	0.18	0.14	0.12	0.11		
8	0.20	0.15	0.12	0.20	0.15	0.12	0.18	0.14	0.11	0.17	0.14	0.11	0.16	0.13	0.11	0.09		
9	0.18	0.14	0.11	0.18	0.14	0.11	0.17	0.13	0.10	0.16	0.12	0.10	0.15	0.12	0.09	0.08		
10	0.17	0.13	0.10	0.16	0.12	0.09	0.15	0.12	0.09	0.15	0.11	0.09	0.14	0.11	0.08	0.07		



Champ® H.I.D. Luminaires

Photometry - Small Housing:

NVMV 150 WATT HSE - GLOBE AND GUARD ONLY		LAMP: 150W HSE						LIGHT OUTPUT UP: 36.0% LIGHT OUTPUT DOWN: 51.4%										
LUMINOUS INTENSITY DISTRIBUTION DIAGRAM 		Ceiling	80%		70%		50%		30%		10%		0					
		Wall	50%	30%	10%	50%	30%	10%	50%	30%	10%	50%	30%	10%	0			
		Floor	20%		20%		20%		20%		20%		0					
		RCR	RCR: Room Cavity Ratio						Coefficients of Utilization (CU)									
		0	0.95	0.95	0.95	0.89	0.89	0.89	0.77	0.77	0.77	0.66	0.66	0.66	0.56	0.56	0.56	0.51
		1	0.76	0.70	0.65	0.70	0.65	0.61	0.60	0.56	0.52	0.50	0.47	0.44	0.41	0.39	0.37	0.32
		2	0.63	0.56	0.49	0.58	0.52	0.46	0.49	0.44	0.39	0.41	0.37	0.33	0.33	0.30	0.27	0.23
		3	0.54	0.46	0.39	0.50	0.42	0.36	0.42	0.36	0.31	0.35	0.30	0.26	0.28	0.24	0.21	0.17
		4	0.47	0.38	0.31	0.43	0.35	0.29	0.36	0.30	0.25	0.30	0.25	0.21	0.24	0.20	0.17	0.13
		5	0.41	0.32	0.26	0.38	0.30	0.24	0.32	0.26	0.21	0.26	0.21	0.17	0.21	0.17	0.14	0.11
		6	0.36	0.28	0.22	0.34	0.26	0.20	0.28	0.22	0.17	0.23	0.18	0.14	0.19	0.15	0.12	0.09
7	0.33	0.24	0.19	0.30	0.23	0.17	0.25	0.19	0.15	0.21	0.16	0.12	0.17	0.13	0.10	0.07		
8	0.29	0.22	0.16	0.27	0.20	0.15	0.23	0.17	0.13	0.19	0.14	0.11	0.16	0.12	0.09	0.06		
9	0.27	0.19	0.14	0.25	0.18	0.13	0.21	0.15	0.11	0.18	0.13	0.09	0.14	0.10	0.07	0.05		
10	0.24	0.17	0.13	0.23	0.16	0.12	0.19	0.14	0.10	0.16	0.12	0.08	0.13	0.09	0.07	0.05		

NVMV 150 WATT HSE - GLOBE AND DOME REFLECTOR		LAMP: 150W HSE						LIGHT OUTPUT UP: 2.4% LIGHT OUTPUT DOWN: 68.1%										
LUMINOUS INTENSITY DISTRIBUTION DIAGRAM 		Ceiling	80%		70%		50%		30%		10%		0					
		Wall	50%	30%	10%	50%	30%	10%	50%	30%	10%	50%	30%	10%	0			
		Floor	20%		20%		20%		20%		20%		0					
		RCR	RCR: Room Cavity Ratio						Coefficients of Utilization (CU)									
		0	0.83	0.83	0.83	0.81	0.81	0.81	0.77	0.77	0.73	0.73	0.73	0.70	0.70	0.70	0.68	
		1	0.70	0.66	0.63	0.68	0.65	0.61	0.64	0.62	0.59	0.61	0.59	0.57	0.58	0.56	0.55	0.53
		2	0.59	0.53	0.49	0.58	0.52	0.48	0.55	0.50	0.46	0.52	0.48	0.45	0.49	0.46	0.43	0.42
		3	0.51	0.44	0.39	0.49	0.43	0.38	0.47	0.41	0.37	0.44	0.40	0.36	0.42	0.38	0.35	0.33
		4	0.44	0.37	0.32	0.43	0.36	0.31	0.41	0.35	0.30	0.39	0.34	0.30	0.37	0.33	0.29	0.27
		5	0.39	0.32	0.26	0.38	0.31	0.26	0.36	0.30	0.26	0.34	0.29	0.25	0.33	0.28	0.25	0.23
		6	0.34	0.27	0.22	0.34	0.27	0.22	0.32	0.26	0.22	0.31	0.25	0.21	0.29	0.25	0.21	0.19
7	0.31	0.24	0.19	0.30	0.24	0.19	0.29	0.23	0.19	0.28	0.22	0.19	0.26	0.22	0.18	0.17		
8	0.28	0.21	0.17	0.27	0.21	0.17	0.26	0.21	0.17	0.25	0.20	0.16	0.24	0.19	0.16	0.15		
9	0.26	0.19	0.15	0.25	0.19	0.15	0.24	0.19	0.15	0.23	0.18	0.14	0.22	0.18	0.14	0.13		
10	0.23	0.17	0.13	0.23	0.17	0.13	0.22	0.17	0.13	0.21	0.16	0.13	0.20	0.16	0.13	0.11		

NVMV 150 WATT HSE - GLOBE AND 30° ANGLE REFLECTOR		LAMP: 150W HSE						LIGHT OUTPUT UP: 7.6% LIGHT OUTPUT DOWN: 64.3%										
LUMINOUS INTENSITY DISTRIBUTION DIAGRAM 		Ceiling	80%		70%		50%		30%		10%		0					
		Wall	50%	30%	10%	50%	30%	10%	50%	30%	10%	50%	30%	10%	0			
		Floor	20%		20%		20%		20%		20%		0					
		RCR	RCR: Room Cavity Ratio						Coefficients of Utilization (CU)									
		0	0.84	0.84	0.84	0.81	0.81	0.81	0.76	0.76	0.76	0.71	0.71	0.71	0.66	0.66	0.66	0.64
		1	0.69	0.65	0.61	0.67	0.63	0.60	0.62	0.59	0.56	0.58	0.55	0.53	0.54	0.52	0.50	0.48
		2	0.59	0.53	0.48	0.57	0.51	0.46	0.53	0.48	0.44	0.49	0.45	0.42	0.46	0.43	0.40	0.38
		3	0.51	0.44	0.38	0.49	0.42	0.37	0.45	0.40	0.36	0.42	0.38	0.34	0.39	0.36	0.33	0.30
		4	0.44	0.37	0.32	0.43	0.36	0.31	0.40	0.34	0.30	0.37	0.32	0.28	0.35	0.31	0.27	0.25
		5	0.39	0.32	0.27	0.38	0.31	0.26	0.35	0.29	0.25	0.33	0.28	0.24	0.31	0.27	0.23	0.21
		6	0.35	0.28	0.23	0.34	0.27	0.22	0.32	0.26	0.22	0.30	0.25	0.21	0.28	0.23	0.20	0.18
7	0.31	0.25	0.20	0.30	0.24	0.19	0.28	0.23	0.19	0.27	0.22	0.18	0.25	0.21	0.17	0.16		
8	0.28	0.22	0.17	0.28	0.21	0.17	0.26	0.20	0.17	0.24	0.20	0.16	0.23	0.19	0.15	0.14		
9	0.26	0.20	0.15	0.25	0.19	0.15	0.24	0.18	0.15	0.22	0.18	0.14	0.21	0.17	0.14	0.12		
10	0.24	0.18	0.14	0.23	0.17	0.14	0.22	0.17	0.13	0.21	0.16	0.13	0.20	0.15	0.12	0.11		

Champ® H.I.D. Luminaires

Photometry - Small Housing:

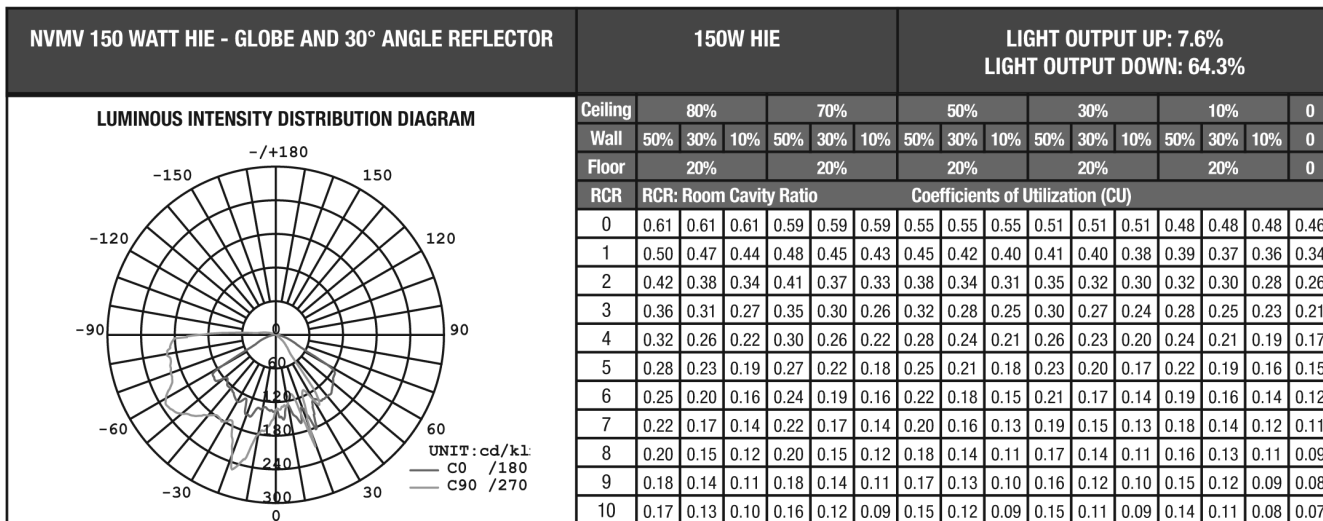
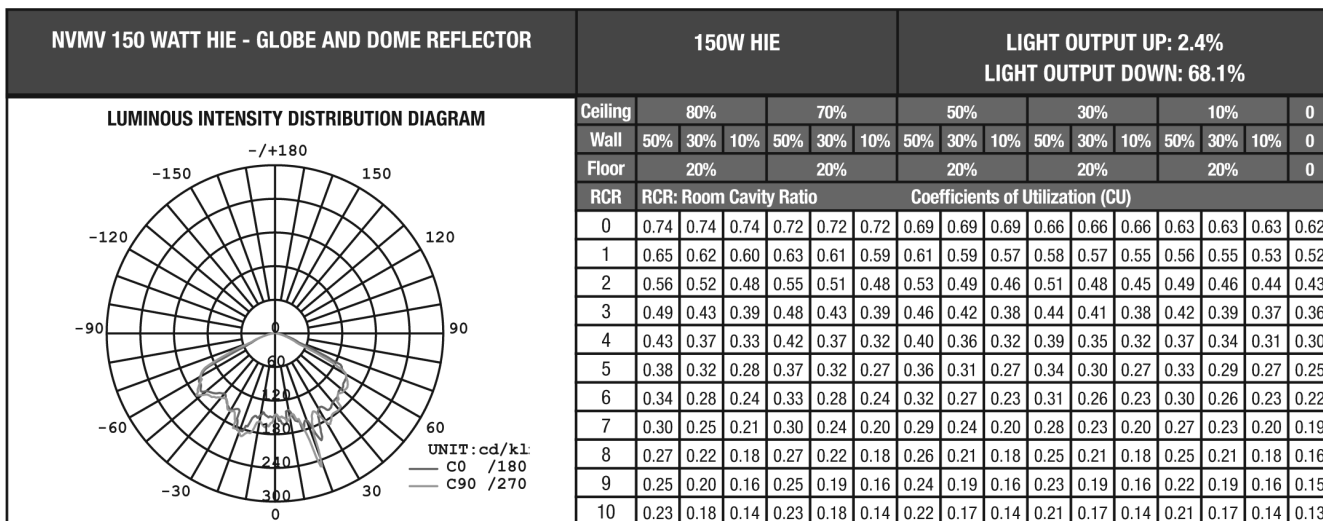
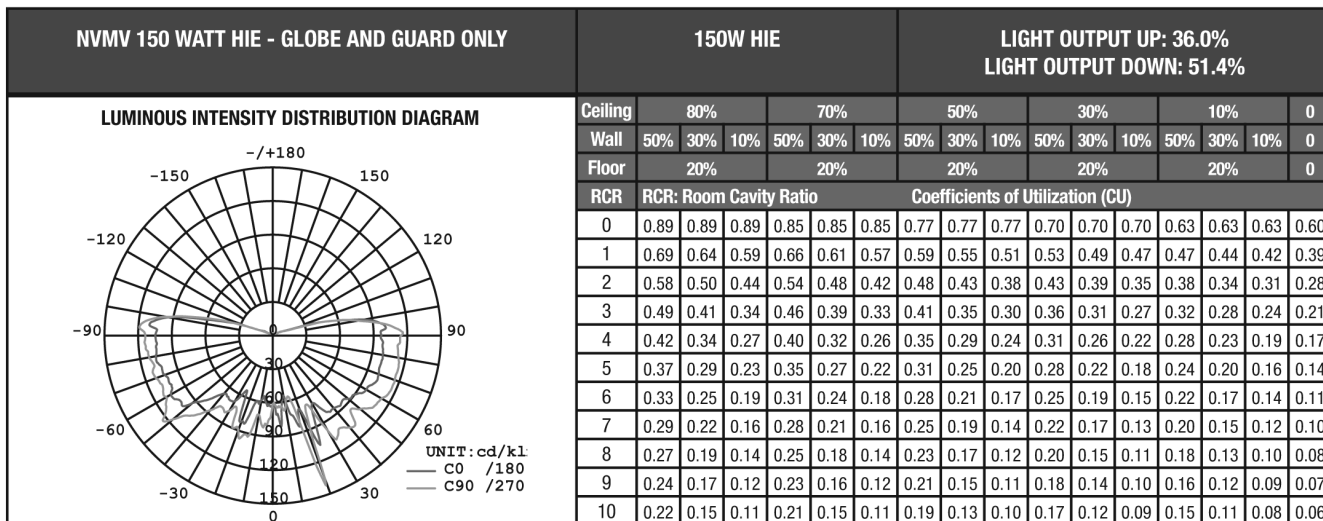

VMV, LMV, DMV, VMV High Wattage & N2MV Series

Globes



G54

G24

G303

Lamp Watts	Luminaire Series	Type	Cat. #
35-150	LMV	Heat/impact resistant	G54
50-175	VMV	Heat/impact resistant	G24
50-250	DMV	Heat/impact resistant	G303
200-400	VMV	Heat/impact resistant	G303
50-175	N2MV	Heat/impact resistant	G303

Reflectors



Dome - Krydon® material

30° Angle - Krydon material

Lamp Watts	Luminaire Series	Dome Cat. #	Angle Cat. #
35-150	LMV	RD636	RA636
50-175	VMV	RD70	RA70
50-250	DMV	RD739	RA739
200-400	VMV	RD739	RA739
50-175	N2MV	RD739	RA740

Guards



P50 - use with G54 globe

P21 - use with G24 globe

P33 - use with G303 globe



P23 - use with reflectors

Lamp Watts	Luminaire Series	Type	Cat. #
35-150	LMV	Copper-free aluminum	P50
50-175	VMV	Copper-free aluminum	P21
50-250	DMV	Stainless steel	P33
200-400	VMV	Stainless steel	P33
Reflectors	All	Stainless steel	P23
50-175	N2MV	Stainless steel	P33

Reflector / Lens



Etched Alzak aluminum reflector/tempered glass lens

Lamp Watts	Luminaire Series	Type	Cat. #
200-400	VMV	Reflector/Lens	GRD4
70-250	DMV	Reflector/Lens	GRD4

Globes - Teflon Coated

Teflon coated for increased shatter protection

Lamp Watts	Luminaire Series	Cat. #
50-175	VMV	G24 S808
50-175	DMV	G303 S808

Alzak is a registered trademark of Alcoa.
Teflon is a registered trademark of E.I. DuPont Co.

VMV, LMV, DMV, VMV High Wattage & N2MV Series

Refractors



R2, R5, PR2, PR3, PR5



GR302, GR303, GR305

Lamp Watts	Luminaire Series	I.E.S. Type	Glass Cat. #	Plastic (100W max. non-hazardous)* Cat. #
50-175	VMV	II	R2	PR2
		III	R3	PR3
		V	R5	PR5
200-400	VMV	II	GR302	
		III	GR305	
		V	GR305	
50-250	DMV	II	GR302	PGR302
		III	GR303	PGR303
		V	GR305	PGR305

50-175 N2MV

*Not available with VMV fluorescent.

I.E.S. Distribution Curves



Type I

Type II

Type III

Type V

Compact Refractors

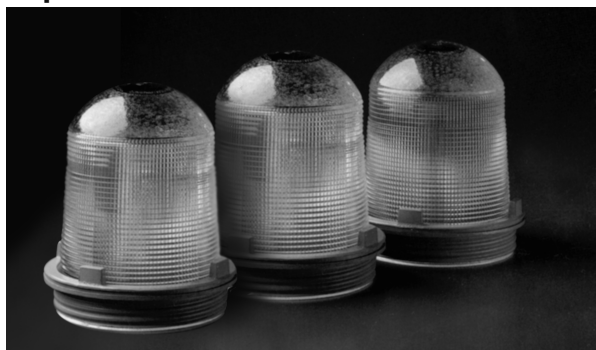

Lamp Watts	Luminaire Series	I.E.S. Type	Glass Cat. #
50-175	VMV	I	G241
		III	G243
		V	G245
			P241

Optional stainless steel wire guard

Crouse-Hinds

by EATON

Safety Lighting Options

Description	Suffix
Quartz Auxiliary Lamp	QTZ
The quartz auxiliary lamp comes to full brightness instantly and remains lit until the H.I.D. lamp attains 60-70% of full illumination. Quartz auxiliary lamps can be used with all DMV, VMV and VMV High Wattage series <i>Champ</i> ® luminaires. Use for non-hazardous applications ONLY.	
VMV luminaires (50-175W) ordered with this option must use large glass refractor optics, not compact refractors.	
100W single ended lamp - Q100CL/DC, Q100DC or 100Q/CL/DC NOT furnished	

Instant Restrike

Factory installed instant restrike device will restart a hot High Pressure Sodium lamp after a momentary power interruption, without the typical delay for cooling.

For use in 50-150W "LX" HPS luminaires. **IR**

For use in 50-100W "LX" HPS luminaires. **TIR**

Ballast-Gard™

BG

Ballast-Gard starter cut-out switch prevents starter pulsing after a time delay of approximately two minutes if the lamp fails to start.

For use in 50-400 watt HPS luminaires only.

3L

3L Photocells

Cl. I, Div. 2, Groups A, B, C, D
Maintains Cl. I, Div. 2 Suitability of Eaton's
Crouse-Hinds Champ® Series Luminaires

V2PC, D2S and EV2IH Series

**The only UL recognized photocells for Class I, Division 2 areas.
Eliminates the need for an explosionproof box!**

Eaton's Crouse-Hinds factory-sealed, field installed photocells offer reliable, dusk-to-dawn lighting control in Class I, Division 2 locations. These photocells are ideal for walkways, security lighting, and any other outdoor lighting application that utilizes Champ® H.I.D. lighting luminaires.

Applications:

Eaton's Crouse-Hinds photocells are designed:

- To provide control for automatic dusk-to-dawn lighting.
- For safety by turning on outdoor luminaires in critical passageways at night.
- To save energy by operating luminaires only when necessary.
- For walkways, parking areas, outdoor process areas, security lighting, or any outdoor lighting application in Class I, Division 2 locations and corrosive environments.
- For use with LMV, DMV, VMV, VMV High Wattage, and FMV Series Champ® lighting luminaires (V2PC Series).
- For use on 35–400 watt H.I.D., incandescent, or fluorescent lighting luminaires.
- For remote mounting in FS boxes (D2S Series).
- For mounting in EIH enclosures for Class I, Division 1 applications (EV2IH Series).

Features:

- Field-installable.
- Solid-state design for performance and dependability.
- Factory sealed components.
Explosionproof enclosure not required for Class I, Division 2 locations.
- Luminaires turn on at 3 footcandles, off at 8 footcandles insuring that the luminaires are operating only when needed.
- Built-in 10 second time delay to eliminate nuisance tripping.
- Eight-year operating life.
- Furnished with 6" stranded 600 volt color coded wire leads.
- Constructed from corrosion-resistant thermoplastic polyester.
- Available on a DS cover for use with any FS/FD box (D2S Series).
- Available in an EIH enclosure for use in Class I, Division 1, Groups B*, C, and D locations (EV2IH Series). No seals required.

*For Group B applications, seal within 1/2" of enclosure in accordance with Section 501-5 of the National Electric Code®.

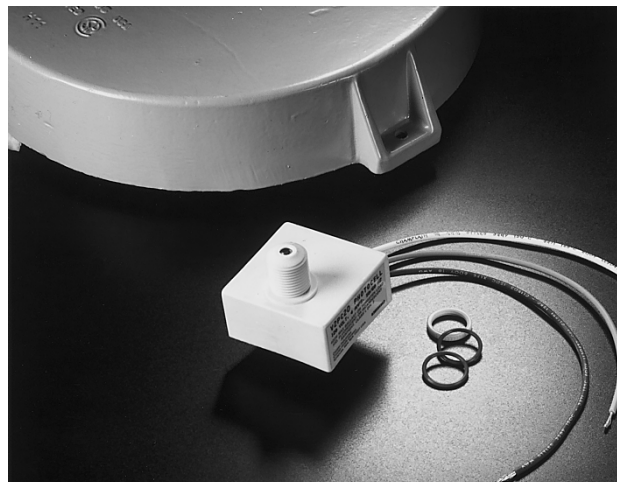

Certifications and Compliances:

V2PC Series and D2S Series

- NEC/CEC:
Class I, Division 2, Groups A, B, C, D
- UL Standard: 844 – Hazardous (Classified) Locations
- CSA: C22.2 No. 55

EV2IH Series

- NEC/CEC:
Class I, Division 1 and 2, Groups B, C, D
Class II, Division 1, Groups E, F, G
Class II, Division 2, Groups F, G
Class III
- NEMA: 3, 4, 7BCD, 9EFG
- UL Standard: 844 – Hazardous (Classified) Locations
- CSA: C22.2 No. 30, 55

Electrical Rating Ranges:

- 120, 208, 220, 240, 277 VAC
- 50 / 60 Hz
- 35–400 watt H.I.D., incandescent, or fluorescent
- V2PC20 – 3.3A max. current rating
- V2PC22 – 1.8A max. current rating
- V2PC27 – 1.4A max. current rating

V2PC, D2S and EV2IH Series

Ordering Information:



Photocell for field installation in lighting fixtures*

Cat. #	Voltage Range	Current Rating
V2PC20	120V, 50/60Hz	3.3A
V2PC22	208-240V, 50/60Hz	1.8A
V2PC27	277V, 50/60Hz	1.4A



Photocell in DS cover for use with FS/FD box

Cat. #	Voltage Range
D2S20	120V, 50/60Hz
D2S208 277	208V-277V



Photocell in EIH enclosure for use in Class I, Division 1, Groups B, C, and D; Class II, Division 1, Groups E, F, and G; and Class III locations

Cat. #	Voltage Range
EV2IH20	120V, 50/60Hz
EV2IH208 277	208-277V 50/60Hz

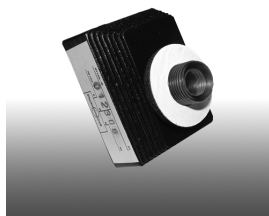

Replacement Photocell for D2S Cover or EIH Enclosure * †

Cat. #	Voltage Range	Current Rating
V2PCT20	120V, 50/60Hz	8.33A
V2PCT208 277	208V-277V 50/60Hz	4.81A - 3.61A depending on voltage

* Must be factory installed in Canada.
 † When mounting in EIH enclosures for Class I, Division 1 applications (EV2IH Series) seals are not required for Groups C & D.

Options:

- To order luminaire with photocell factory installed:
1. Specify luminaire dedicated supply voltage (not MT, DT, or TT)
 2. Add photocell Cat. No. to fixture Cat. No. as follows:

- V2PC20
- V2PC22
- V2PC27

Example: VMVSJ070GP/120-V2PC20 is a 120V 60Hz luminaire with a factory installed photocell.

Note: Only the V2PC is available as a factory installed photocell.

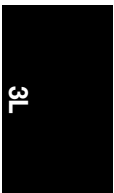

3L Photocells

Cl. I, Div. 2, Groups A, B, C, D
 Maintains Cl. I, Div. 2 Suitability of Eaton's
 Crouse-Hinds Champ® Series Luminaires

V2PC, D2S and EV2IH Series

Dimensions: In Inches:

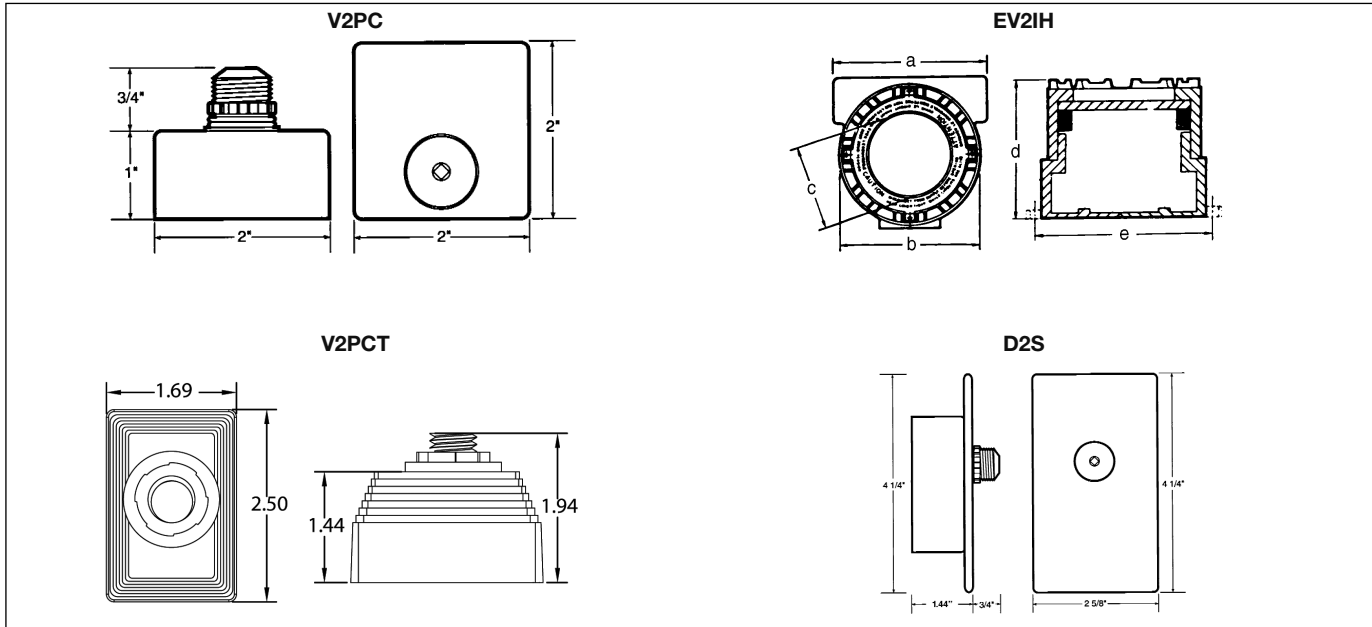

Cat. #	a	b	c	d	e
EV2IH	5.00	4.25	2.60	4.54	5.25

3L

High Intensity Discharge (H.I.D.) Luminaires Hazardous

Description	Page No.
Application/Selection	see page 1028
Class I and Class II Hazardous Area Lighting	
Integrally Ballasted Luminaires	
EVLS Hazard•Gard® Series	see pages 1029–1044
EVL P Hazard•Gard® Series	see page 1045
EVM Hazard•Gard® Series	see page 1056

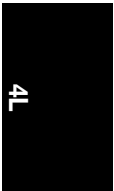

4L High Intensity Discharge (H.I.D.) Luminaires

Hazardous Application and Selection Quick Selector Chart

Applications:

Luminaires contained in this section are for use:

- In indoor or outdoor hazardous locations
- As general area or spot lighting applications
- Where longer lamp life provides desirable maintenance cost savings and return on investment through use of fewer luminaires, circuits and ancillary apparatus
- Where relamping and maintenance difficulties require longer lamp life

Considerations for Selection:

Environmental:

- Make sure luminaire meets NEC/CEC requirements for area in which it will be used

Lighting levels required:

- Can luminaire accept lamp of sufficient size to yield desired light level?

**Table 500.8(C)
Identification Numbers.**

Maximum Temperature Deg. C	Temp. Class Deg. F	Temp. Class (T Code)
450	842	T1
300	572	T2
280	536	T2A
260	500	T2B
230	446	T2C
215	419	T2D
200	392	T3
180	356	T3A
165	329	T3B
160	320	T3C
135	275	T4
120	248	T4A
100	212	T5
85	185	T6

Quick Selector Chart

Series	NEC Compliance	Electrical Characteristics		Ballast
		Watts	Volts	
EVLS <i>Hazard•Gard®</i>	Cl. I, Groups B (with suffix GB), C, D	HPS: 50, 70, 100, 150	Multi-tap: 120, 208, 240, 277V/60Hz	
	Cl. II	Metal Halide: 70, 100, 175	480V/60Hz	
	Cl. III	Pulse Start Metal Halide: 150, 175	Tri-tap: 120, 277, 347V/60Hz 220V/60Hz 220/240V /50Hz	
EVM <i>Hazard•Gard®</i>	Cl. I, Groups B, C, D	50, 70, 100, 150, 175, 200, 250, 320, 400 (Mogul base)	120, 208, 240, 277, 347, 480, 600, MT	High power factor, constant wattage, reactor or autotransformer, integral
	Cl. II, Groups E, F, G	50, 70, 100, 150, 175 (Mogul base)	120, 208, 240, 277, 347, 480, 600, MT	
<i>Champ®</i> Series (see Section 3L)	Cl. II, Groups E, F, G	70, 100, 150, 175 (Mogul base)	120, 208, 240, 277, 347, 480, 600, MT	High power factor, constant wattage integral
EVLP <i>Hazard•Gard®</i>	Cl. I, Groups B, C, D	70, 100, 150, 175 (Medium base)	120, 208, 240, 277, 347, 480, MT, TT	High power factor, constant wattage, reactor or autotransformer, integral
		70, 100, 150, 175, 200, 250 (Mogul base)		
	Cl. II, Groups E, F, G Cl. III	70, 100 (Medium base) 70, 100, 150, 175 (Mogul base)	120, 208, 240, 277, 347, 480, MT, TT	

EVLS Hazard•Gard®

Compact & Rugged, Class I, Zone 1, Div. 1 Explosionproof Luminaire

Cl. I, Div. 1, Group B
(with suffix GB), C, D
Cl. I, Zone 1, Group IIB + H₂
(with suffix GB)
Cl. II, Cl. III & Simultaneous Presence

UL and cUL Listed
Wet locations (UL1598)
Marine locations (UL1598A)
Type 4X, IP66

4L

A compact, affordable, explosionproof luminaire that has the best overall temperature performance ratings in its class!

Eaton's Crouse-Hinds EVLS Hazard•Gard® is perfect as a general area lighting workhorse where space constraints exist. EVLS Hazard•Gard® is easy to install, 175 watts and less, has select options that are just right for your budget — AND it's Class I, Division 1, Group B with GB option!

Applications:

Eaton's Crouse-Hinds EVLS Hazard•Gard Lighting Fixtures are used for general lighting and task lighting in:

- Areas where flammable or explosive vapors or gases are present
- Confined spaces or heavy process industry facilities
- Petroleum refineries; chemical, petrochemical and pharmaceutical plants; oil terminals; gas plants
- Waste treatment facilities
- Drilling platforms and other coastal and offshore hazardous areas

Features:

- Compact and rugged - a Division 1 luminaire that fits in tight spaces
- Smooth turning two start Acme threads for mounting modules and globe attachments save time and eliminate installation damage
- Quick-connect design facilitates easy installation and saves money - install and wire the mounting module, and then screw in luminaire to make the electrical connection
- Best overall T-rating in the industry for a medium-base HID lamp - use in elevated ambient and illuminate the most volatile areas of your facility - optimal safety in your high-risk areas
- Factory-sealed - wired and sealed with no external sealing fittings required in Groups B, C, and D
- An adapter module is available for direct connection to existing Hazard•Gard modules such as the EV22 ceiling mount

Certification & Compliances:

UL (844) and cUL Listed (CSA C22.2 No. 137) for:

- Class I, Division 1, Groups B (with suffix GB), C, D
- Class I, Zone 1, Group IIB + H₂ (with suffix GB)
- Class II, Class III & Simultaneous Presence
- Wet locations (UL1598), Marine locations (UL1598A), Type 4X, IP66

Standard Materials:

- Bodies, mounting modules and cast guards – copper-free aluminum
- Wire guard – stainless steel
- Globe – heat- and impact-resistant glass
- Gaskets – silicone and neoprene

Standard Finishes:

- Epoxy powder coat paint

Ratings (Electrical Size):

Sources/Wattages:

- HID Medium Base (initial offering)
HPS: 50, 70, 100, 150 watt
Metal Halide: 70, 100, 175 watt
Pulse Start Metal Halide: 150, 175 watt

Voltages:

- Multi-tap (120, 208, 240, 277V/60 Hz)
- 480V/60 Hz
- Tri-tap (120, 277, 347V/60 Hz)
- 220V/60 Hz
- 220/240V (or 230V)/50 Hz

Transformer Types:

- HX-HPF Standard
- CWA Standard on 175W
CWA Constant Wattage Autotransformer
CWI Constant Wattage Insulation Transformer
Available for HPS and MH, for most voltages and wattages (Additional voltages available on request.)

Conduit Entries:

- ¾" and 1" NPT – pendant, ceiling and wall mount
- 1½" NPT – stanchion

Options:

Description	Suffix
• Instant Restrike (HPS)	IR
• Ballast-Gard™ (HPS)	BG
• Group B Suitability	GB

Accessories:

Description	Suffix
• Dome Reflector	RD725
• Angle Reflector	RA725
• Guard	EV502 or P515



Two Start Acme Threads



Quick Connect Design



Adapter Module Available

4L

4L EVLS Hazard•Gard®

Cl. I, Div. 1, Groups B
(with suffix GB), C, D
Cl. I, Zone 1, Group IIB + H₂
(with suffix GB)
Cl. II, Cl. III & Simultaneous Presence

UL and cUL Listed
Wet locations (UL1598),
Marine locations (UL1598A)
Type 4X, IP66

Compact & Rugged, Class I, Zone 1, Div. 1 Explosionproof Luminaire

Mounting Modules:

Existing For EVI, EVLP, EVM (must use EVSA adapter)			New Mounting Modules	
Type	Conduit	Catalog Number	For EVLS Only	
Type	Conduit	Catalog Number	Conduit	Catalog Number
Adapter		EVSA		
Pendant	3/4"	EVMP2	3/4"	EVSP2
	1"	EVMP3	1"	EVSP3
Ceiling & Wall Box	25mm		25mm	EVSP25
	32mm		32mm	EVSP32
	3/4"	EV22	3/4"	EVSC2
	1"	EV33	1"	EVSC3
Wall Bracket Arm	25mm		25mm	EVSC25
	32mm		32mm	EVSC32
	Use EV22 or EV33 box with	EV87	3/4"	EVSW2
			1"	EVSW3
Stanchion	25mm		25mm	EVSW25
	32mm		32mm	EVSW32
	1 1/4"	EVMJ4	1 1/2"	EVSJ5
Bulkhead	1 1/4"	EVJ2	3/4"	EVSB2
			25mm	EVSB25

Family Tree:

Existing Mounting
Modules used on
EVI, EVLP, EVM
(must use EVSA adapter)

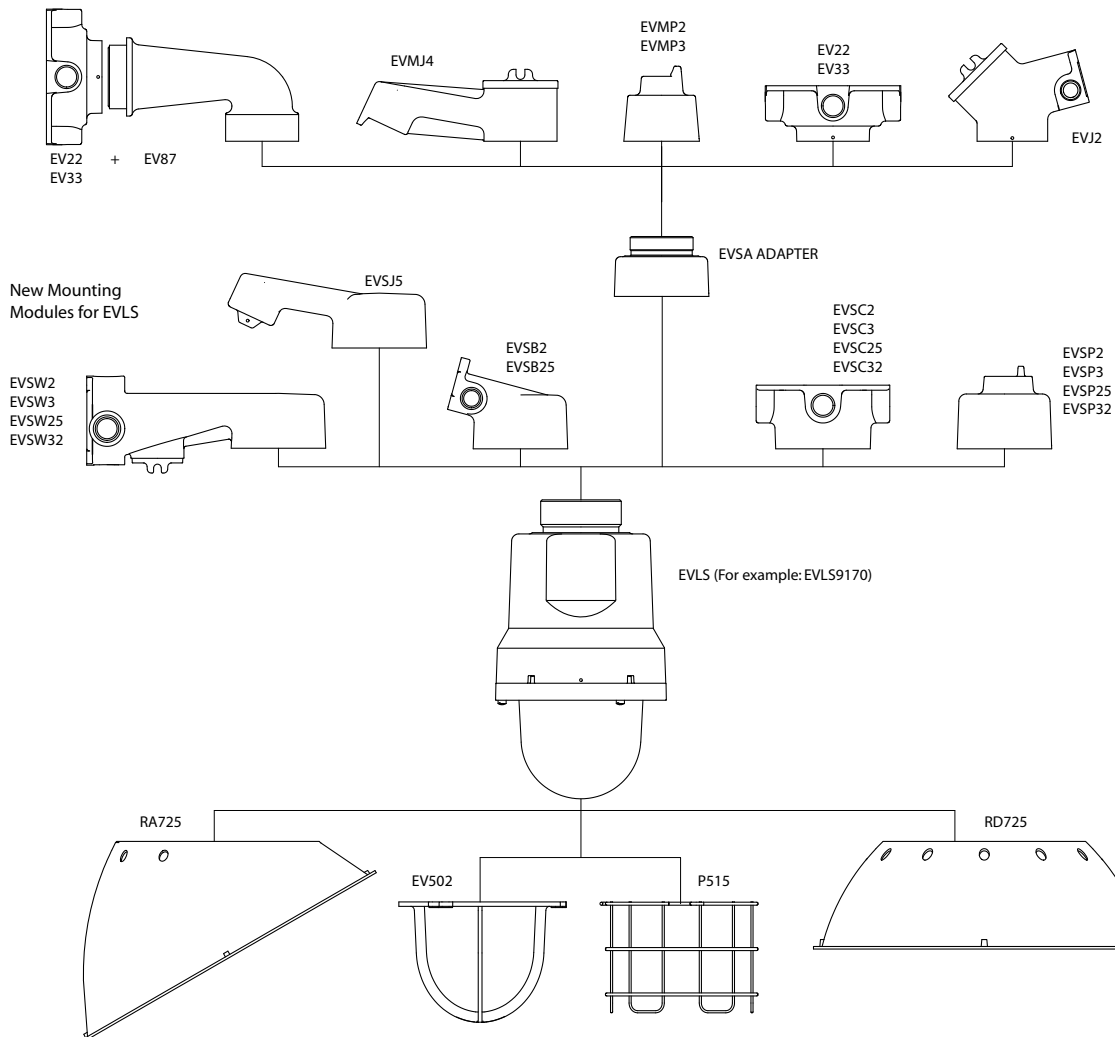

4L

**Compact & Rugged, Class I, Zone 1,
Div. 1 Explosionproof Luminaire**

Ordering Reference Sheet:

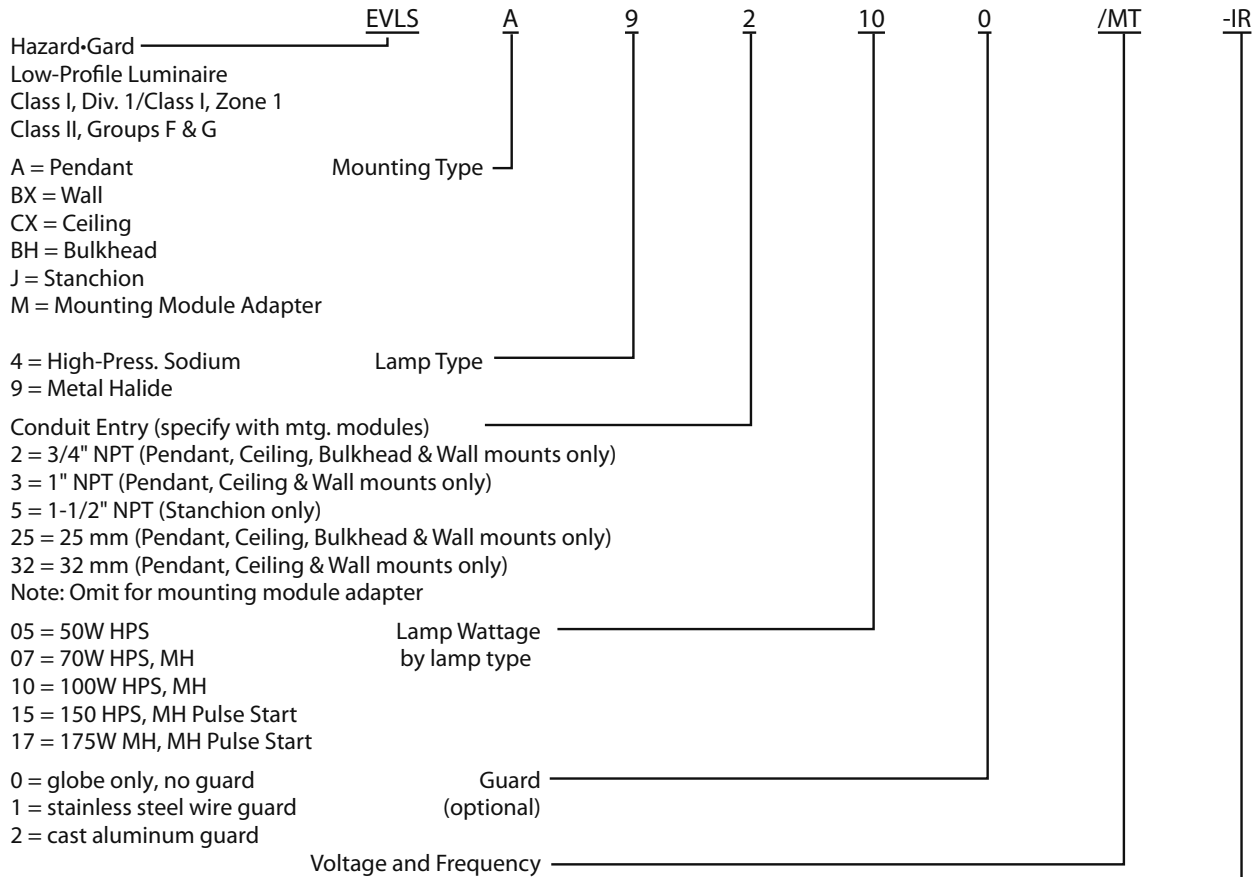

	HPS				MH				
	50	70	100	150	70	100	150 PS	175	175 PS
DT	x								
MT		x	x	x	x	x	x		x
TT		x	x	x	x	x		x	x
120	x	x	x	x	x	x	x		x
208		x	x	x	x	x	x		x
220		x	x	x	x				
220 50	x	x	x	x	x	x	x		
240		x	x	x	x	x	x		x
240 50	x	x	x	x	x	x	x		
277	x	x	x	x	x	x	x		x
347		x	x	x	x	x			x
480		x	x	x		x			x

BG = Ballast Guard (lamp type S only)
CWI = SCE Ballast
GB = Group B suitability
IR = Instant Restrike (lamp type S only)
S828 = Pulse Start (175W & 150W MH only)

Options _____

Note: BG and IR options cannot be installed together.

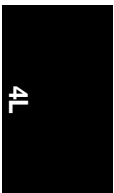

4L EVLS Hazard•Gard®

**Compact & Rugged, Class I, Zone 1,
Div. 1 Explosionproof Luminaire**

Cl. I, Div. 1, Groups B
(with suffix GB), C, D
Cl. I, Zone 1, Group IIB + H₂
(with suffix GB)
Cl. II, Cl. III & Simultaneous Presence

UL and cUL Listed
Wet locations (UL1598),
Marine locations (UL1598A)
Type 4X, IP66

Temperature Performance Data:

Watts	Ambient Temp °C	Class I, Div. 1 & Zone 1	Class II (Dust) and Class III	Supply Wire Temp °C
High Pressure Sodium				
50W	40	T5	T5	90
	55	T4A	—	90
	65	T4A	—	105
70W	40	T5	T5	90
	55	T4A	—	90
	65	T4A	—	105
100W	40	T4A	T3C	90
	55	T4	—	90
	65	T4	—	105
150W	40	T4A	T3C	90
	55	T4	—	90
Metal Halide (including Pulse Start [PS] as indicated)				
70W	40	T5	T4A	90
	55	T4A	—	90
	65	T4A	—	105
100W	40	T4A	T4	90
	55	T4A	—	90
	65	T4	—	105
150 PS	40	T3C	—	90
175W	40	T3C	—	90
175 PS	40	T3C	—	90

Net Luminaire Weights (lbs.):

Luminaire Series	Lamp Watts	Weight with Globe & Wire Guard
High Pressure Sodium		
EVLS4	50W	18.5
	70W	21.5
	100W	22.5
	150W	24
Metal Halide		
EVLS9	70W	20
	100W	20.5
	150 PS	23
	175W	23
	175 PS	23
Add for cast guard:		
		1
Add for mounting modules:		
Pendant		2
Ceiling		3.5
Stanchion		3
Bulkhead		2.5
Wall		5.5
Adapter		2
Add for reflectors:		
Dome		1.5
Angle		2

4L

EVLS Hazard•Gard®

Cl. I, Div. 1, Groups B
(with suffix GB), C, D
Cl. I, Zone 1, Group IIB + H₂ (with
suffix GB)
Cl. II, Cl. III & Simultaneous Presence

UL and cUL Listed **4L**
Wet locations (UL1598),
Marine locations (UL1598A)
Type 4X, IP66

Compact & Rugged, Class I, Zone 1, Div. 1 Explosionproof Luminaire

Ordering Information – High Pressure Sodium:



PENDANT

BULKHEAD

Wattage	Hub Size	PENDANT			BULKHEAD		
		No Guard	Wire Guard	Cast Guard	No Guard	Wire Guard	Cast Guard
50W	3/4"	EVLSA42050	EVLSA42051	EVLSA42052	EVLSBH42050	EVLSBH42051	EVLSBH42052
	1"	EVLSA43050	EVLSA43051	EVLSA43052			
	1 1/2"						
70W	25 mm	EVLSA425050	EVLSA425051	EVLSA425052	EVLSBH425050	EVLSBH425051	EVLSBH425052
	32 mm	EVLSA432050	EVLSA432051	EVLSA432052			
	3/4"	EVLSA42070	EVLSA42071	EVLSA42072	EVLSBH42070	EVLSBH42071	EVLSBH42072
	1"	EVLSA43070	EVLSA43071	EVLSA43072			
	1 1/2"						
	25 mm	EVLSA425070	EVLSA425071	EVLSA425072	EVLSBH425070	EVLSBH425071	EVLSBH425072
100W	32 mm	EVLSA432070	EVLSA432071	EVLSA432072			
	3/4"	EVLSA42100	EVLSA42101	EVLSA42102	EVLSBH42100	EVLSBH42101	EVLSBH42102
	1"	EVLSA43100	EVLSA43101	EVLSA43102			
	1 1/2"						
	25 mm	EVLSA425100	EVLSA425101	EVLSA425102	EVLSBH425100	EVLSBH425101	EVLSBH425102
	32 mm	EVLSA432100	EVLSA432101	EVLSA432102			
150W	3/4"	EVLSA42150	EVLSA42151	EVLSA42152	EVLSBH42150	EVLSBH42151	EVLSBH42152
	1"	EVLSA43150	EVLSA43151	EVLSA43152			
	1 1/2"						
	25 mm	EVLSA425150	EVLSA425151	EVLSA425152	EVLSBH425150	EVLSBH425151	EVLSBH425152
	32 mm	EVLSA432150	EVLSA432151	EVLSA432152			

Complete catalog number as follows:

Standard Voltage Ballasts

	NEC/UL			CEC/CSA (cUL)					Export			
	Multi-tap	120V	480V	Tri-Tap 120V	208V CWI	240V CWI	480V CWI	600V CWI	220V 60 Hz	220V 50 Hz	240V 50 Hz	
Voltage												
Suffix	/MT	/120	/480	/TT	/120	/208CWI	/240CWI	/480CWI	/600CWI	/220	/220 50	/240 50

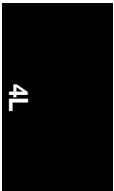

4L EVLS Hazard•Gard®

**Compact & Rugged, Class I, Zone 1,
Div. 1 Explosionproof Luminaire**

Cl. I, Div. 1, Groups B
(with suffix GB), C, D
Cl. I, Zone 1, Group IIB + H₂
(with suffix GB)
Cl. II, Cl. III & Simultaneous Presence

UL and cUL Listed
Wet locations (UL1598),
Marine locations (UL1598A)
Type 4X, IP66

Ordering Information — High Pressure Sodium (Cont'd):



Wattage	Hub Size	WALL			CEILING		
		No Guard	Wire Guard	Cast Guard	No Guard	Wire Guard	Cast Guard
50W	3/4"	EVLSBX42050	EVLSBX42051	EVLSBX42052	EVLSCX42050	EVLSCX42051	EVLSCX42052
	1"	EVLSBX43050	EVLSBX43051	EVLSBX43052	EVLSCX43050	EVLSCX43051	EVLSCX43052
	1 1/2"						
	25 mm	EVLSBX425050	EVLSBX425051	EVLSBX425052	EVLSCX425050	EVLSCX425051	EVLSCX425052
70W	32 mm	EVLSBX432050	EVLSBX432051	EVLSBX432052	EVLSCX432050	EVLSCX432051	EVLSCX432052
	3/4"	EVLSBX42070	EVLSBX42071	EVLSBX42072	EVLSCX42070	EVLSCX42071	EVLSCX42072
	1"	EVLSBX43070	EVLSBX43071	EVLSBX43072	EVLSCX43070	EVLSCX43071	EVLSCX43072
	1 1/2"						
100W	25 mm	EVLSBX425070	EVLSBX425071	EVLSBX425072	EVLSCX425070	EVLSCX425071	EVLSCX425072
	32 mm	EVLSBX432070	EVLSBX432071	EVLSBX432072	EVLSCX432070	EVLSCX432071	EVLSCX432072
	3/4"	EVLSBX42100	EVLSBX42101	EVLSBX42102	EVLSCX42100	EVLSCX42101	EVLSCX42102
	1"	EVLSBX43100	EVLSBX43101	EVLSBX43102	EVLSCX43100	EVLSCX43101	EVLSCX43102
150W	1 1/2"						
	25 mm	EVLSBX425100	EVLSBX425101	EVLSBX425102	EVLSCX425100	EVLSCX425101	EVLSCX425102
	32 mm	EVLSBX432100	EVLSBX432101	EVLSBX432102	EVLSCX432100	EVLSCX432101	EVLSCX432102
	3/4"	EVLSBX42150	EVLSBX42151	EVLSBX42152	EVLSCX42150	EVLSCX42151	EVLSCX42152
150W	1"	EVLSBX43150	EVLSBX43151	EVLSBX43152	EVLSCX43150	EVLSCX43151	EVLSCX43152
	1 1/2"						
	25 mm	EVLSBX425150	EVLSBX425151	EVLSBX425152	EVLSCX425150	EVLSCX425151	EVLSCX425152
150W	32 mm	EVLSBX432150	EVLSBX432151	EVLSBX432152	EVLSCX432150	EVLSCX432151	EVLSCX432152

4L

Complete catalog number as follows:

Standard Voltage Ballasts

Voltage	NEC/UL			CEC/CSA (cUL)					Export			
	Multi-tap	120V	480V	Tri-Tap 120V	208V CWI	240V CWI	480V CWI	600V CWI	220V 60 Hz	220V 50 Hz	240V 50 Hz	
Suffix	/MT	/120	/480	/TT	/120	/208CWI	/240CWI	/480CWI	/600CWI	/220	/220 50	/240 50

EVLS Hazard•Gard®

Cl. I, Div. 1, Groups B (with suffix GB), C, D
 Cl. I, Zone 1, Group IIB + H₂ (with suffix GB)
 Cl. II, Cl. III & Simultaneous Presence

UL and cUL Listed
 Wet locations (UL1598),
 Marine locations (UL1598A)
 Type 4X, IP66

4L

Compact & Rugged, Class I, Zone 1, Div. 1 Explosionproof Luminaire

Ordering Information — High Pressure Sodium (Cont'd):



STANCHION

ADAPTER

Wattage	Hub Size							Luminaire less mounting module and guard
		No Guard	Wire Guard	Cast Guard	No Guard	Wire Guard	Cast Guard	
50W	Adapter 1 1/2"	EVLSJ45050	EVLSJ45051	EVLSJ45052	EVLSM4050	EVLSM4051	EVLSM4052	EVLS4050
70W	Adapter 1 1/2"	EVLSJ45070	EVLSJ45071	EVLSJ45072	EVLSM4070	EVLSM4071	EVLSM4072	EVLS4070
100W	Adapter 1 1/2"	EVLSJ45100	EVLSJ45101	EVLSJ45102	EVLSM4100	EVLSM4101	EVLSM4102	EVLS4100
150W	Adapter 1 1/2"	EVLSJ45150	EVLSJ45151	EVLSJ45152	EVLSM4150	EVLSM4151	EVLSM4152	EVLS4100

Complete catalog number as follows:

STANDARD VOLTAGE BALLASTS

Voltage	NEC/UL			CEC/CSA (cUL)						Export		
	Multi-tap	120V	480V	Tri-Tap 120V	208V CWI	240V CWI	480V CWI	600V CWI	220V 60 Hz	220V 50 Hz	240V 50 Hz	
Suffix	/MT	/120	/480	/TT	/120	/208CWI	/240CWI	/480CWI	/600CWI	/220	/220 50	/240 50

Photometrics - EVLS High Pressure Sodium

Fixture with Globe and Domed Reflector (less guard) **EVLSA42150RD725**
 Lamp: 150W/B17 High Pressure Sodium (HPS)

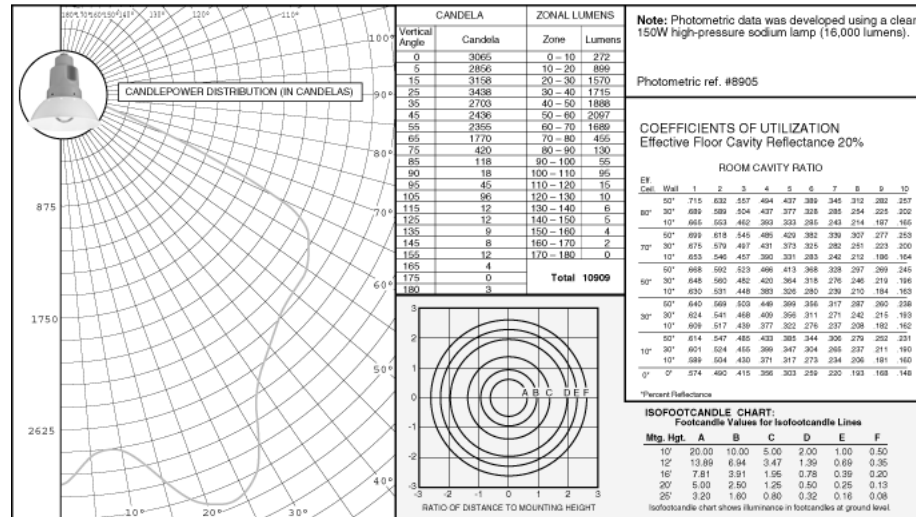

4L EVLS Hazard•Gard®

Compact & Rugged, Class I, Zone 1, Div. 1 Explosionproof Luminaire

Cl. I, Div. 1, Groups B (with suffix GB), C, D
 Cl. I, Zone 1, Group IIB + H₂ (with suffix GB)
 Cl. II, Cl. III & Simultaneous Presence

UL and cUL Listed
 Wet locations (UL1598),
 Marine locations (UL1598A)
 Type 4X, IP66

Photometrics - EVLS High Pressure Sodium:

Fixture with Globe and Guard EVLSA42151
 Lamp: 150W/B17 High Pressure Sodium (HPS)

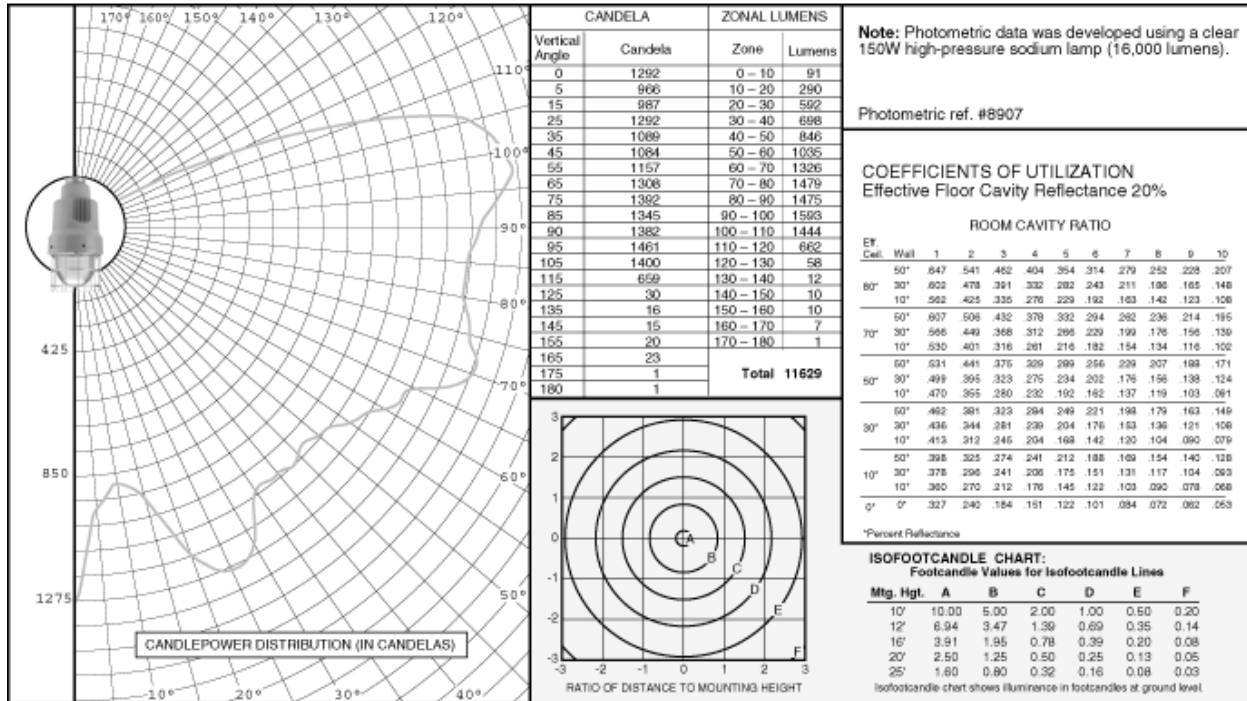

Photometrics - EVLS High Pressure Sodium:

Fixture with Globe and Angled Reflector (less guard) EVLSA42150RA725
 Lamp: 150W/B17 High Pressure Sodium (HPS)

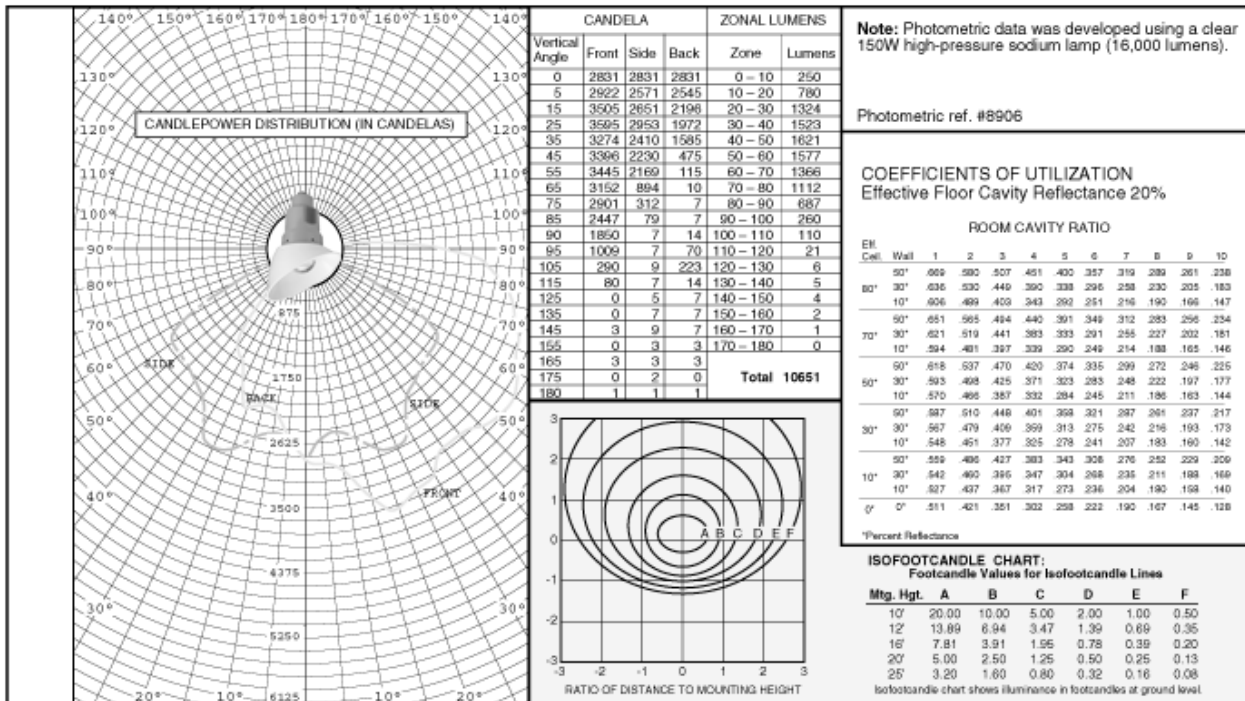

EVLS Hazard•Gard®

Cl. I, Div. 1, Groups B
(with suffix GB), C, D
Cl. I, Zone 1, Group IIB + H₂
(with suffix GB)
Cl. II, Cl. III & Simultaneous Presence

UL and cUL Listed
Wet locations (UL1598),
Marine locations (UL1598A)
Type 4X, IP66

4L

Compact & Rugged, Class I, Zone 1, Div. 1 Explosionproof Luminaire

Ordering Information – Pulse Start Metal Halide:



Wattage	Hub Size	PENDANT			BULKHEAD		
		No Guard	Wire Guard	Cast Guard	No Guard	Wire Guard	Cast Guard
150W	3/4"	EVLSA92150-S828	EVLSA92151-S828	EVLSA92152-S828	EVLSBH92150-S828	EVLSBH92151-S828	EVLSBH92152-S828
	1"	EVLSA93150-S828	EVLSA93151-S828	EVLSA93152-S828			
	1 1/2"						
	25 mm	EVLSA925150-S828	EVLSA925151-S828	EVLSA925152-S828	EVLSBH925150-S828	EVLSBH925151-S828	EVLSBH925152-S828
175W	32 mm	EVLSA932150-S828	EVLSA932151-S828	EVLSA932152-S828			
	3/4"	EVLSA92170-S828	EVLSA92171-S828	EVLSA92172-S828	EVLSBH92170-S828	EVLSBH92171-S828	EVLSBH92172-S828
	1"	EVLSA93170-S828	EVLSA93171-S828	EVLSA93172-S828			
	1 1/2"						
175W	25 mm	EVLSA925170-S828	EVLSA925171-S828	EVLSA925172-S828	EVLSBH925170-S828	EVLSBH925171-S828	EVLSBH925172-S828
	32 mm	EVLSA932170-S828	EVLSA932171-S828	EVLSA932172-S828			

Ordering Information – Pulse Start Metal Halide:



Wattage	Hub Size	WALL			CEILING		
		No Guard	Wire Guard	Cast Guard	No Guard	Wire Guard	Cast Guard
150W	3/4"	EVLSBX92150-S828	EVLSBX92151-S828	EVLSBX92152-S828	EVLSCX92150-S828	EVLSCX92151-S828	EVLSCX92152-S828
	1"	EVLSBX93150-S828	EVLSBX93151-S828	EVLSBX93152-S828	EVLSCX93150-S828	EVLSCX93151-S828	EVLSCX93152-S828
	1 1/2"						
	25 mm	EVLSBX925150-S828	EVLSBX925151-S828	EVLSBX925152-S828	EVLSCX925150-S828	EVLSCX925151-S828	EVLSCX925152-S828
175W	32 mm	EVLSBX932150-S828	EVLSBX932151-S828	EVLSBX932152-S828	EVLSCX932150-S828	EVLSCX932151-S828	EVLSCX932152-S828
	3/4"	EVLSBX92170-S828	EVLSBX92171-S828	EVLSBX92172-S828	EVLSCX92170-S828	EVLSCX92171-S828	EVLSCX92172-S828
	1"	EVLSBX93170-S828	EVLSBX93171-S828	EVLSBX93172-S828	EVLSCX93170-S828	EVLSCX93171-S828	EVLSCX93172-S828
	1 1/2"						
175W	25 mm	EVLSBX925170-S828	EVLSBX925171-S828	EVLSBX925172-S828	EVLSCX925170-S828	EVLSCX925171-S828	EVLSCX925172-S828
	32 mm	EVLSBX932170-S828	EVLSBX932171-S828	EVLSBX932172-S828	EVLSCX932170-S828	EVLSCX932171-S828	EVLSCX932172-S828

4L

4L EVLS Hazard•Gard®

**Compact & Rugged, Class I, Zone 1,
Div. 1 Explosionproof Luminaire**

Cl. I, Div. 1, Groups B
(with suffix GB), C, D
Cl. I, Zone 1, Group IIB + H₂
(with suffix GB)
Cl. II, Cl. III & Simultaneous Presence

UL and cUL Listed
Wet locations (UL1598),
Marine locations (UL1598A)
Type 4X, IP66

Ordering Information – Pulse Start Metal Halide (Cont'd):



STANCHION

ADAPTER

Wattage	Hub Size	STANCHION			ADAPTER			Luminaire less mounting module and guard
		No Guard	Wire Guard	Cast Guard	No Guard	Wire Guard	Cast Guard	
150W	Adapter				EVLSM9150-S828	EVLSM9151-S828	EVLSM9152-S828	EVLS9150-S828
	3/4"							
	1"							
	1 1/2"	EVLSJ95150-S828	EVLSJ95151-S828	EVLSJ95152-S828				
	25 mm							
	32 mm							
175W	Adapter				EVLSM9170-S828	EVLSM9171-S828	EVLSM9172-S828	EVLS9100-S828
	3/4"							EVLS9170-S828
	1"							
	1 1/2"	EVLSJ95170-S828	EVLSJ95171-S828	EVLSJ95172-S828				
	25 mm							
	32 mm							

4L	Complete catalog number as follows:	Standard Voltage Ballasts		
		NEC/UL		
	Voltage	Multi-tap	120V	480V
	Suffix	/MT	/120	/480

EVLS Hazard•Gard®

Cl. I, Div. 1, Groups B
(with suffix GB), C, D
Cl. I, Zone 1, Group IIB + H₂
(with suffix GB)
Cl. II, Cl. III & Simultaneous Presence

UL and cUL Listed
Wet locations (UL1598),
Marine locations (UL1598A)
Type 4X, IP66

4L

Compact & Rugged, Class I, Zone 1, Div. 1 Explosionproof Luminaire

Ordering Information – Metal Halide:



PENDANT

BULKHEAD

Wattage	Hub Size	Pendant			Bulkhead		
		No Guard	Wire Guard	Cast Guard	No Guard	Wire Guard	Cast Guard
70W	3/4"	EVLSA92070	EVLSA92071	EVLSA92072	EVLSBH92070	EVLSBH92071	EVLSBH92072
	1"	EVLSA93070	EVLSA93071	EVLSA93072			
	1 1/2"						
	25 mm	EVLSA925070	EVLSA925071	EVLSA925072	EVLSBH925070	EVLSBH925071	EVLSBH925072
	32 mm	EVLSA932070	EVLSA932071	EVLSA932072			
100W	3/4"	EVLSA92100	EVLSA92101	EVLSA92102	EVLSBH92100	EVLSBH92101	EVLSBH92102
	1"	EVLSA93100	EVLSA93101	EVLSA93102			
	1 1/2"						
	25 mm	EVLSA925100	EVLSA925101	EVLSA925102	EVLSBH925100	EVLSBH925101	EVLSBH925102
	32 mm	EVLSA932100	EVLSA932101	EVLSA932102			
175W†	3/4"	EVLSA92170	EVLSA92171	EVLSA92172	EVLSBH92170	EVLSBH92171	EVLSBH92172
	1"	EVLSA93170	EVLSA93171	EVLSA93172			
	1 1/2"						
	25 mm	EVLSA925170	EVLSA925171	EVLSA925172	EVLSBH925170	EVLSBH925171	EVLSBH925172
	32 mm	EVLSA932170	EVLSA932171	EVLSA932172			

†Export only.

Complete catalog number as follows:

Standard Voltage Ballasts

	NEC/UL			CEC/CSA (cUL)					Export				
Voltage	Multi-tap	120V	480V	Tri-Tap	120V	208V CWI	240V CWI	480V CWI	600V CWI	220V 60 Hz	220V 50 Hz	230V* 50 Hz	240V 50 Hz
Suffix	/MT	/120	/480	/TT	/120	/208CWI	/240CWI	/480CWI	/600CWI	/220	/220 50	/230 50	/240 50

*Available for 175W only.

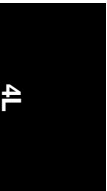

4L EVLS Hazard•Gard®

**Compact & Rugged, Class I, Zone 1,
Div. 1 Explosionproof Luminaire**

Cl. I, Div. 1, Group B
(with suffix GB), C, D
Cl. I, Zone 1, Group IIB + H₂
(with suffix GB)
Cl. II, Cl. III &
Simultaneous Presence

UL and cUL Listed
Wet locations (UL1598)
Marine locations (UL1598A)
Type 4X, IP66

Ordering Information – Metal Halide (Cont'd):



WALL

CEILING

Wattage	Hub Size	WALL			CEILING		
		No Guard	Wire Guard	Cast Guard	No Guard	Wire Guard	Cast Guard
70W	3/4"	EVLSBX92070	EVLSBX92071	EVLSBX92072	EVLSCX92070	EVLSCX92071	EVLSCX92072
	1"	EVLSBX93070	EVLSBX93071	EVLSBX93072	EVLSCX93070	EVLSCX93071	EVLSCX93072
	1 1/2"	EVLSBX925070	EVLSBX925071	EVLSBX925072	EVLSCX925070	EVLSCX925071	EVLSCX925072
	25 mm 32 mm	EVLSBX932070	EVLSBX932071	EVLSBX932072	EVLSCX932070	EVLSCX932071	EVLSCX932072
100W	3/4"	EVLSBX92100	EVLSBX92101	EVLSBX92102	EVLSCX92100	EVLSCX92101	EVLSCX92102
	1"	EVLSBX93100	EVLSBX93101	EVLSBX93102	EVLSCX93100	EVLSCX93101	EVLSCX93102
	1 1/2"	EVLSBX925100	EVLSBX925101	EVLSBX925102	EVLSCX925100	EVLSCX925101	EVLSCX925102
	25 mm 32 mm	EVLSBX932100	EVLSBX932101	EVLSBX932102	EVLSCX932100	EVLSCX932101	EVLSCX932102
175W†	3/4"	EVLSBX92170	EVLSBX92171	EVLSBX92172	EVLSCX92170	EVLSCX92171	EVLSCX92172
	1"	EVLSBX93170	EVLSBX93171	EVLSBX93172	EVLSCX93170	EVLSCX93171	EVLSCX93172
	1 1/2"	EVLSBX925170	EVLSBX925171	EVLSBX925172	EVLSCX925170	EVLSCX925171	EVLSCX925172
	25 mm 32 mm	EVLSBX932170	EVLSBX932171	EVLSBX932172	EVLSCX932170	EVLSCX932171	EVLSCX932172

†Export only.

Complete catalog number as follows:

Standard Voltage Ballasts

	NEC/UL				CEC/CSA (cUL)					Export			
	Multi-tap	120V	480V	Tri-Tap	120V	208V CWI	240V CWI	480V CWI	600V CWI	220V 60 Hz	220V 50 Hz	230V* 50 Hz	240V 50 Hz
Voltage													
Suffix	/MT	/120	/480	/TT	/120	/208CWI	/240CWI	/480CWI	/600CWI	/220	/220 50	/230 50	/240 50

*Available for 175W only.

4L

**Compact & Rugged, Class I, Zone 1,
Div. 1 Explosionproof Luminaire**

Ordering Information – Metal Halide (Cont'd):



STANCHION

ADAPTER

Wattage	Hub Size	No Guard	Wire Guard	Cast Guard	Luminaire less mounting module and guard			
					No Guard	Wire Guard	Cast Guard	
70W	Adapter				EVLSM9070	EVLSM9071	EVLSM9072	EVLS9070
	1 1/2"	EVLSJ95070	EVLSJ95071	EVLSJ95072				
100W	Adapter				EVLSM9100	EVLSM9101	EVLSM9102	EVLS9100
	1 1/2"	EVLSJ95100	EVLSJ95101	EVLSJ95102				
175W†	Adapter				EVLSM9170	EVLSM9171	EVLSM9172	EVLS9100 EVLS9170
	3/4" 1 1/2"	EVLSJ95170	EVLSJ95171	EVLSJ95172				

†Export only.

Complete catalog number as follows:

Voltage	Standard Voltage Ballasts											
	NEC/UL			CEC/CSA (cUL)						Export		
Multi-tap	120V	480V	Tri-Tap	120V	208V CWI	240V CWI	480V CWI	600V CWI	220V 60 Hz	220V 50 Hz	230V* 50 Hz	240V 50 Hz
Suffix	/MT	/120	/480	/TT	/120	/208CWI	/240CWI	/480CWI	/600CWI	/220	/220 50	/230 50 /240 50

*Available for 175W only.

EVLS Metal Halide:

**Fixture with Globe and Domed Reflector (less guard) EVLSA92170RD725
Lamp: 150W/ED17 Metal Halide (MH)**

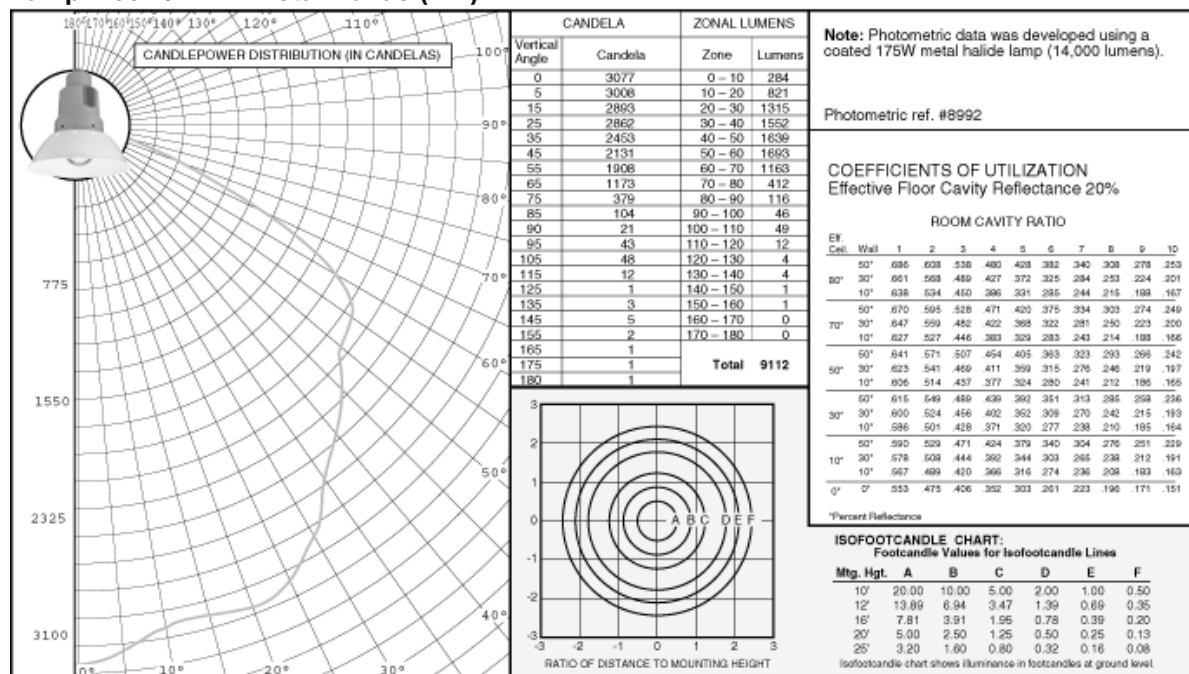

4L

EVLS Hazard•Gard®

Cl. I, Div. 1, Group B
(with suffix GB), C, D
Cl. I, Zone 1, Group IIB + H₂
(with suffix GB)
Cl. II, Cl. III &
Simultaneous Presence

UL and cUL Listed
Wet locations (UL1598)
Marine locations (UL1598A)
Type 4X, IP66

**Compact & Rugged, Class I, Zone 1,
Div. 1 Explosionproof Luminaire**

EVLS Metal Halide:

Fixture with Globe and Guard EVLSA92171

Lamp: 175W/ED17 Metal Halide (MH)

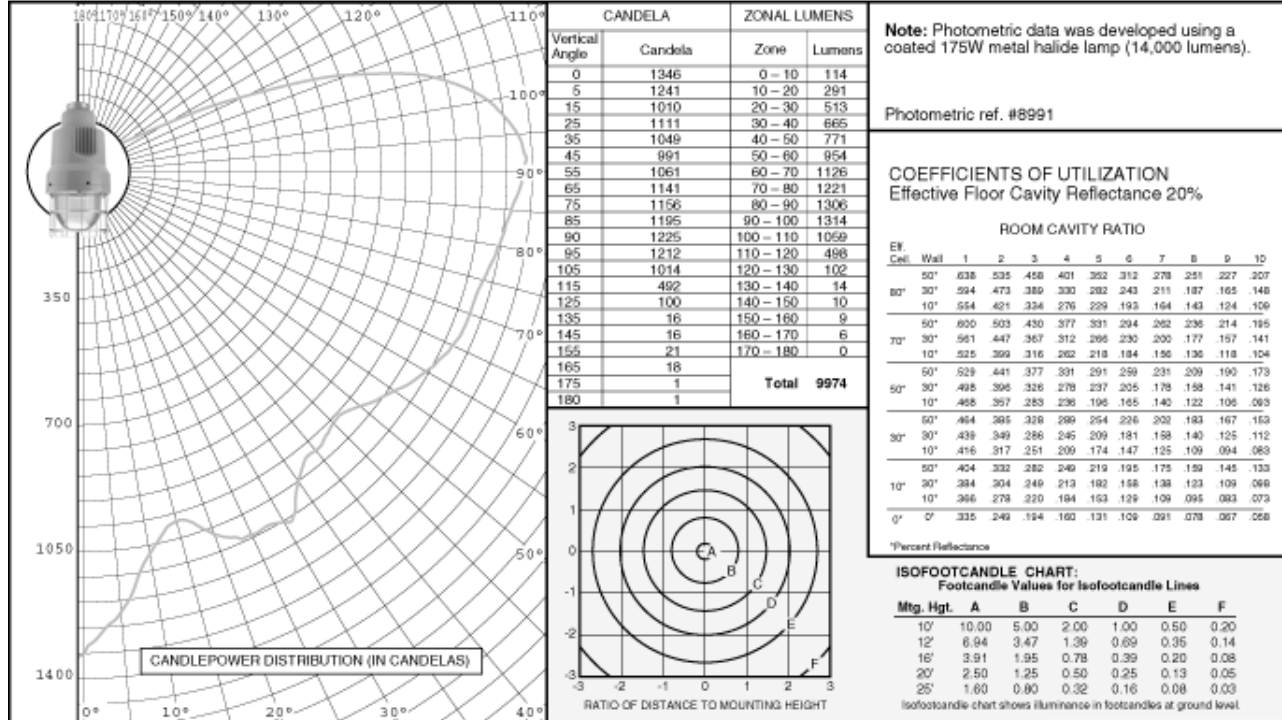

EVLS Metal Halide:

Fixture with Globe and Angled Reflector (less guard) EVLSA92170RA725

Lamp: 175W/ED17 Metal Halide (MH)

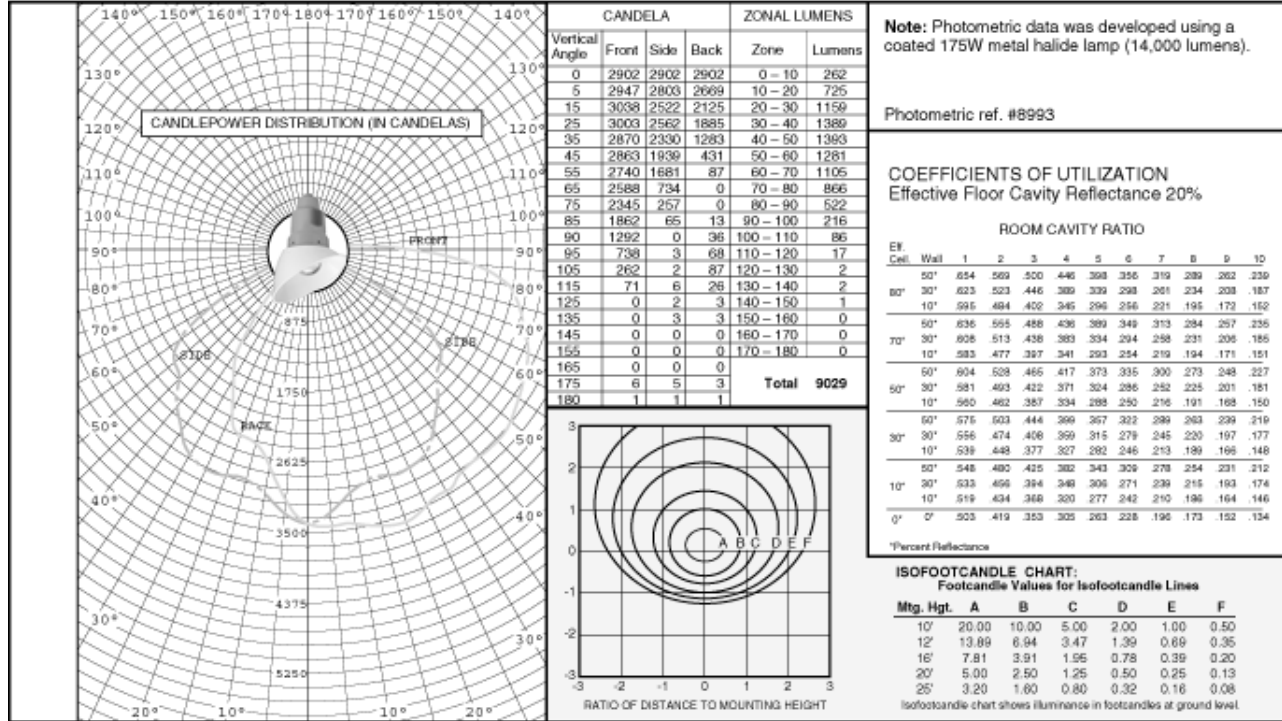

4L

**Compact & Rugged, Class I, Zone 1,
Div. 1 Explosionproof Luminaire**

Dimensions - Shown with new mounting modules:

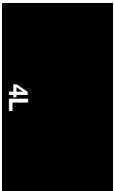
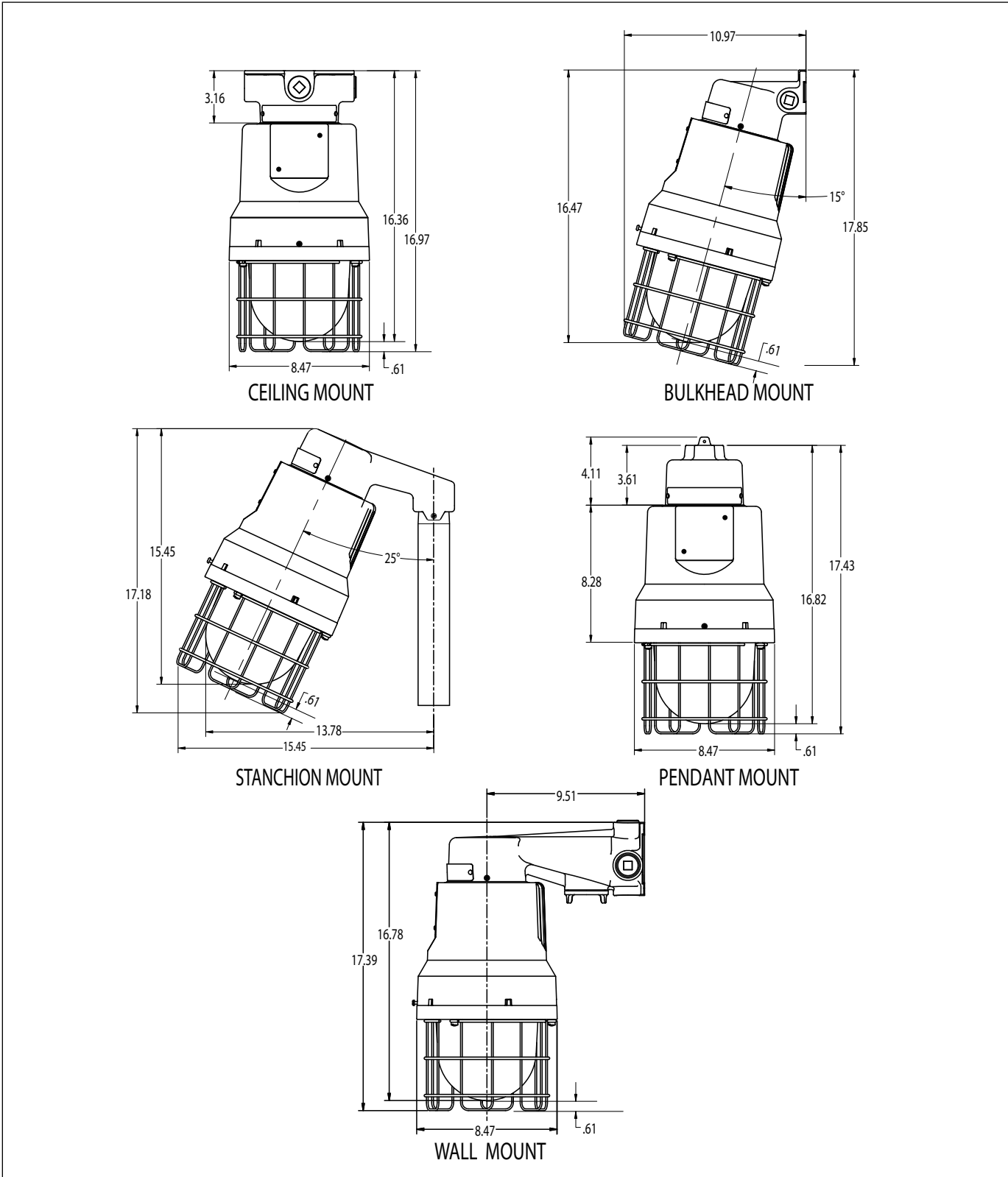

4L EVLS Hazard•Gard®

**Compact & Rugged, Class I, Zone 1,
Div. 1 Explosionproof Luminaire**

Cl. I, Div. 1, Group B
(with suffix GB), C, D
Cl. I, Zone 1, Group IIB + H₂
(with suffix GB)
Cl. II, Cl. III &
Simultaneous Presence

UL and cUL Listed
Wet locations (UL1598)
Marine locations (UL1598A)
Type 4X, IP66

Dimensions - Shown with existing mounting modules plus EVSA Adapter:

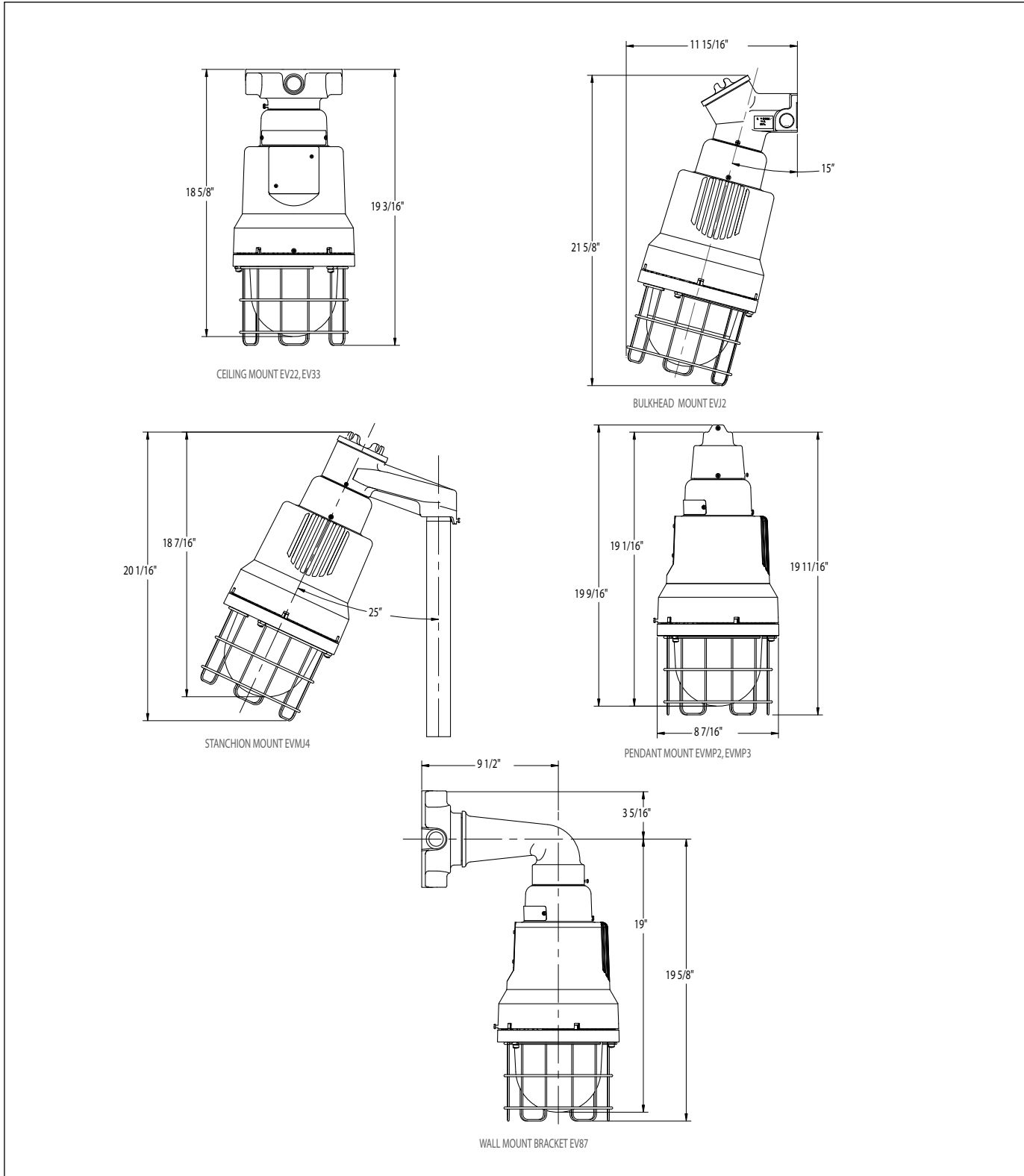

4L

EVLP Low Profile Hazard•Gard® (H.I.D.) Luminaires

Medium and Mogul Base

Cl. I, Div. 1, Groups B
(GB suffix), C, D
Cl. I, Zone 1, Groups IIB + H₂
(with suffix – GB), IIB, IIA
Cl. II, Div. 1, Groups E, F, G;
Class III

Marine & Wet
Locations
3, 3R, 4, 4X; IP66

4L

Applications:

Eaton's Crouse-Hinds Low Profile Hazard•Gard® luminaires are used in:

- Areas where flammable or explosive vapors or gases are present
- Hazardous areas, both indoors and outdoors, where long life and low maintenance costs are desired
- Petroleum refineries, chemical, petrochemical and pharmaceutical plants, oil terminals, gas plants and other heavy process industry facilities
- Waste treatment facilities
- Drilling platforms and other coastal and offshore hazardous areas

Features and Benefits:

- Small, compact size is perfect where low mounting restrictions are a concern.
- Two start Acme threaded construction allows for easier assembly, installation and maintenance.
- Lightweight copper-free aluminum housing with powdered epoxy finish for superior corrosion resistance.
- All exterior hardware is corrosion-resistant stainless steel.
- Four mounting arrangements: pendant, ceiling, wall bracket and stanchion suit any lighting layout.
- Wide range of light sources and wattages to meet specific lighting needs.
- Marine and NEMA 4X construction suitable for outdoor, hose down, marine and corrosive environments.
- Integral ballast for lowest installed cost.
- High power factor (90%+) ballasts allows more fixtures per circuit.
- Uses same mounting modules as the standard Hazard•Gard® for easy retrofitting when the EVLP is the preferred choice.
- Internally fluted glass globe reduces glare and distributes light evenly – ideal for adverse environments typical of industrial facilities.
- Krydon® construction dome and angle reflectors – won't rust, corrode, dent, chip or peel
- Now available in components – luminaire body, mounting module, guard, reflectors – allowing for easy stocking for Quick Ship requirements.



Certifications and Complies:

- NEC and CEC:
 - Class I, Division 1, Groups B (with suffix GB), C, D – All Wattages
 - Class I, Zone 1, Groups IIB + H₂ (with suffix GB), IIB, IIA – All Wattages
 - Class II and Class III
- UL Standards:
 - 844, Hazardous (Classified) Locations
 - 1598 Luminaires
 - 1598A Marine Locations
- CSA Standards
 - C22.2 No. 137

Options:

Description	Suffix
• Group B suitability	GB
• Ballast-Gard™ (HPS only)	BG
• Instant restrike (Mogul Base only)	IR
70–150W LX HPS	
Cannot use with BG Option	
• Fused (not suitable for marine applications).....	S658*
• Quartz auxiliary lighting (Mogul Base only)	QTZ
Cannot use with IR option	
Uses 100W single ended double contract lamp	
Quartz lamp not included	
• Factory assembled with lamps	FA

*When ordering fuses for luminaires, option S658, you must specify the operating voltage. S658 cannot be ordered with /MT in the catalog number.

Accessories:

Description	Cat. #
Dome reflector	RD739
Angle reflector	RA739

Standard Materials:

- Mounting modules, cover, ballast housing, globe holder – copper-free aluminum
- Globe – heat and impact resistant glass
- Exterior hardware – stainless steel
- Reflectors (dome & angle) – Krydon® fiberglass-reinforced polyester

Standard Finishes:

- Copper-free aluminum – *Corro-free™* powdered epoxy
- Krydon – white
- Stainless steel guard

Ratings (Electrical/Size):

Sources/Wattage:

- Medium Base 70–150W HPS, 70–175W MH
- Mogul Base 70–150W HPS, 70–250W MH

Voltages:

- Medium & Mogul H.I.D.
 - 120V 60Hz
 - Multi-tap (120, 208, 240, 277V 60Hz)
 - Tri-tap (120, 277, 347V 60Hz)
 - 480V 60Hz
 - Other voltages – consult Eaton's Crouse-Hinds

Conduit Entries:

- ¾", 1" NPT – pendant, wall bracket, ceiling
- 1¼" NPT – stanchion



4L

EVLP Low Profile Hazard•Gard®

Medium Base

Cl. I, Div. 1, Groups B (GB suffix), C, D
 Cl. I, Zone 1, Groups IIB + H₂ (with GB suffix), IIB, IIA
 Cl. II, Div. 1, Groups E, F, G; Class III

Marine & Wet Locations
 3, 3R, 4, 4X; IP66

Ordering Information:

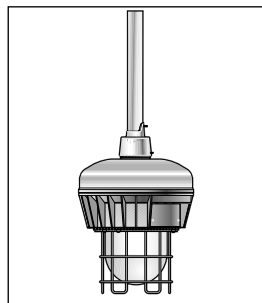

Pendant Mount

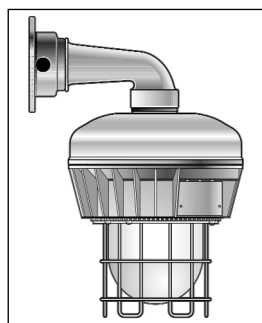

†Wall Bracket Mount

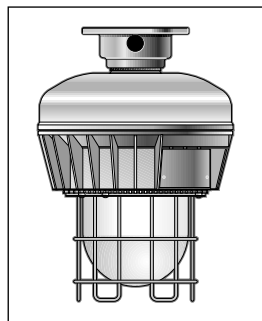

†Ceiling Mount

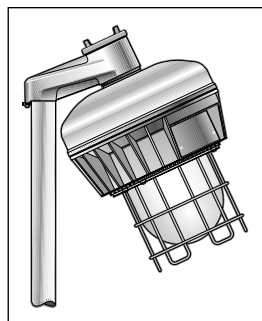

Stanchion Mount

Watt	Pendant		Wall Bracket		Ceiling		Stanchion		Luminaire Body Less Mounting Module & Guard
	Hub Size (In.)	With Guard Cat. #	With Guard Cat. #	With Guard Cat. #	With Guard Cat. #	With Guard Cat. #	With Guard Cat. #	Cat. #	
High Pressure Sodium									
70W	3/4	EVLPA142071	EVLPBX142071	EVLPCX142071					EVLPA14070
	1	EVLPA143071	EVLPBX143071	EVLPCX143071					
100W	1/4				EVLPCX144071				
	3/4	EVLPA142101	EVLPBX142101	EVLPCX142101					EVLPA14100
150W	1	EVLPA143101	EVLPBX143101	EVLPCX143101					
	1/4				EVLPCX144101				
150W	3/4	EVLPA142151	EVLPBX142151	EVLPCX142151					EVLPA14151
	1	EVLPA143151	EVLPBX143151	EVLPCX143151					
	1/4				EVLPCX144151				
	Pulse Start Metal Halide								
150W	3/4	EVLPA192151 S828	EVLPBX192151 S828	EVLPCX192151 S828					EVLPA19150 S828
	1	EVLPA193151 S828	EVLPBX193151 S828	EVLPCX193151 S828					
175W	1/4				EVLPCX194151 S828				
	3/4	EVLPA192171 S828	EVLPBX192171 S828	EVLPCX192171 S828					EVLPA19175 S828
	1	EVLPA193171 S828	EVLPBX193171 S828	EVLPCX193171 S828					
	1/4				EVLPCX194171 S828				
Metal Halide									
70W	3/4	EVLPA192071	EVLPBX192071	EVLPCX192071					EVLPA19070
	1	EVLPA193071	EVLPBX193071	EVLPCX193071					
100W	1/4				EVLPCX194071				
	3/4	EVLPA192101	EVLPBX192101	EVLPCX192101					EVLPA19100
175W	1	EVLPA193101	EVLPBX193101	EVLPCX193101					
	1/4				EVLPCX194101				
175W	3/4	EVLPA192171	EVLPBX192171	EVLPCX192171					EVLPA19175
	1	EVLPA193171	EVLPBX193171	EVLPCX193171					
	1/4				EVLPCX194171				

Complete Catalog Number as follows:

Standard Voltage Ballasts – 60Hz

Voltage Suffix	Multi Tap /MT	NEC/UL		CEC/CSA (cUL)	
		120V /120	480V /480	Tri Tap /TT	120V /120
1.					

Optional Voltage Ballasts – 50 or 60Hz

Voltage Suffix	*CEC/CSA (cUL)– CWI Isolated Ballasts			EXPORT			
	208V CWI /208CWI	240V CWI /240CWI	600V CWI /600CWI	220V 60Hz /220	220V 50Hz /220 50	230V 50Hz /230 50	240V 50Hz /240 50
2.	150W HPS Luminaires only						
	• 55V lamps – add suffix "LX"						
	• 100V lamps – add suffix "CE"						

†Ceiling and bracket mounts have 4 hubs: 3 are plugged.

*CWI Isolated Ballasts are only available for high pressure sodium and 175W metal halide (non pulse start) luminaires.

EVLP Low Profile Hazard•Gard®

Mogul Base

Cl. I, Div. 1, Groups B (GB suffix), C, D
 Cl. I, Zone 1, Groups IIB + H₂
 (with GB suffix), IIB, IIA
 Cl. II, Div. 1, Groups E, F, G; Class III

Marine & Wet Locations
 3, 3R, 4, 4X; IP66

4L

Ordering Information:

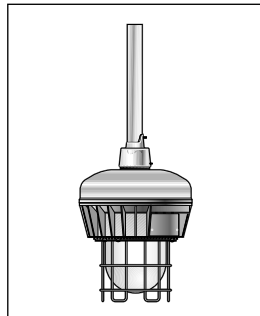

Pendant Mount

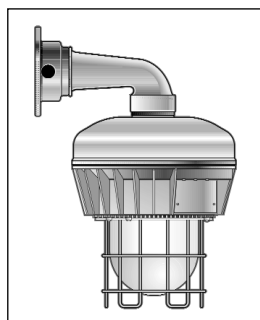

†Wall Bracket Mount

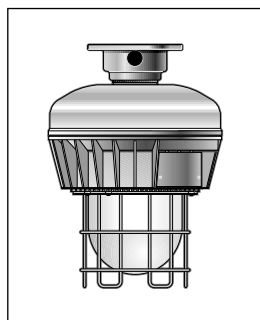

†Ceiling Mount

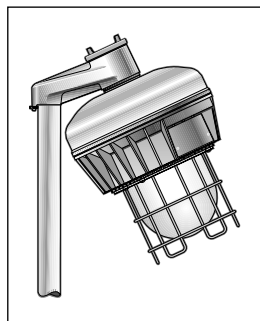

Stanchion Mount

Watt	Hub Size (In.)	Pendant	Wall Bracket	Ceiling	Stanchion	Luminaire Body Less Mounting Module & Guard
		With Guard Cat. #	With Guard Cat. #	With Guard Cat. #	With Guard Cat. #	Cat. #
High Pressure Sodium						
70W	3/4	EVLPA042071	EVLPBX042071	EVLPCX042071		EVLPA04070
	1	EVLPA043071	EVLPBX043071	EVLPCX043071		
	1 1/4				EVLPA044071	
100W	3/4	EVLPA042101	EVLPBX042101	EVLPCX042101		EVLPA04100
	1	EVLPA043101	EVLPBX043101	EVLPCX043101		
	1 1/4				EVLPA044101	
150W	3/4	EVLPA042151	EVLPBX042151	EVLPCX042151		EVLPA04150
	1	EVLPA043151	EVLPBX043151	EVLPCX043151		
	1 1/4				EVLPA044151	
Pulse Start Metal Halide						
150W	3/4	EVLPA092151S828	EVLPBX092151S828	EVLPCX092151S828		EVLPA09150S828
	1	EVLPA093151S828	EVLPBX093151S828	EVLPCX093151S828		
	1 1/4				EVLPA094151S828	
175W	3/4	EVLPA092171S828	EVLPBX092171S828	EVLPCX092171S828		EVLPA09170S828
	1	EVLPA093171S828	EVLPBX093171S828	EVLPCX093171S828		
	1 1/4				EVLPA094171S828	
200W	3/4	EVLPA092201S828	EVLPBX092201S828	EVLPCX092201S828		EVLPA09201S828
	1	EVLPA093201S828	EVLPBX093201S828	EVLPCX093201S828		
	1 1/4				EVLPA094201S828	
250W	3/4	EVLPA092251S828	EVLPBX092251S828	EVLPCX092251S828		EVLPA09250S828
	1	EVLPA093251S828	EVLPBX093251S828	EVLPCX093251S828		
	1 1/4				EVLPA094251S828	
Metal Halide						
70W	3/4	EVLPA092071	EVLPBX092071	EVLPCX092071		EVLPA09070
	1	EVLPA093071	EVLPBX093071	EVLPCX093071		
	1 1/4				EVLPA094071	
100W	3/4	EVLPA092101	EVLPBX092101	EVLPCX092101		EVLPA09100
	1	EVLPA093101	EVLPBX093101	EVLPCX093101		
	1 1/4				EVLPA094101	
175W	3/4	EVLPA092171	EVLPBX092171	EVLPCX092171		EVLPA09170
	1	EVLPA093171	EVLPBX093171	EVLPCX093171		
	1 1/4				EVLPA094171	
250W	3/4	EVLPA092251	EVLPBX092251	EVLPCX092251		EVLPA09250
	1	EVLPA093251	EVLPBX093251	EVLPCX093251		
	1 1/4				EVLPA094251	

Complete Catalog Number as follows:

Standard Voltage Ballasts – 60Hz

Voltage Suffix	Multi Tap /MT	NEC/UL		CEC/CSA (cUL)	
		120V /120	480V /480	Tri Tap /TT	120V /120

Optional Voltage Ballasts – 50 or 60Hz

Voltage Suffix	*CEC/CSA (cUL)– CWI Isolated Ballasts				EXPORT		
	208V CWI /208CWI	240V CWI /240CWI	600V CWI /600CWI	220V 60Hz /220	220V 50Hz /220 50	230V 50Hz /230 50	240V 50Hz /240 50

2. 150W HPS Luminaires only
 • 55V lamps – add suffix "LX"
 • 100V lamps – add suffix "CE"
 Example: EVLPA043151/MT-LX

†Ceiling and wall bracket mounts have 4 hubs: 3 are plugged.

*CWI Isolated Ballasts are only available for high pressure sodium and 175W–250W metal halide (non pulse start) luminaires.

4L EVLP Low Profile Hazard•Gard®

Ordering by Components

EVLP Luminaires are available in components.

A complete luminaire consists of:

- Mounting Module
- Luminaire Body
- Guard, Dome Reflector or Angle Reflector

Mounting Modules:

Type	Conduit	Cat. #
Pendant	3/4"	EVMP2
	1"	EVMP3
Ceiling & Wall Box	3/4"	EV22
	1"	EV33
Wall Bracket Arm	Use EV22 or EV33 box with EV87	EV87
Stanchion	1 1/4"	EVMJ4
Guards		
Medium		EV511
Mogul		EV512
Reflectors		
Dome		RD739
Angle		RA739

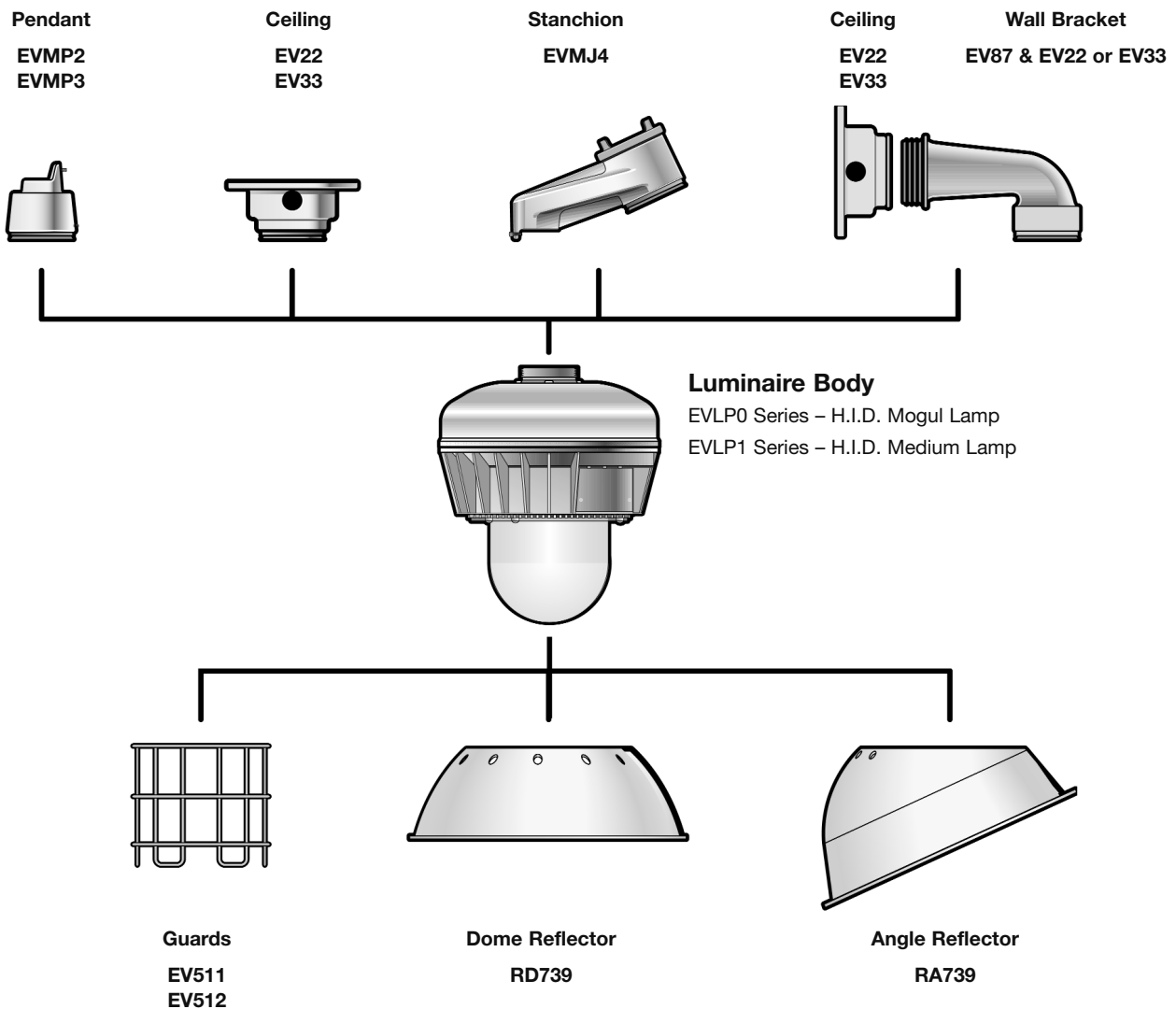

4L

Medium Base Lamp Luminaires:

Maximum Ambient	Watts	Class I, Group B (w/GB suffix) Groups C, D			Class II, Groups E, F, G Class III Simultaneous Presence		Supply Wire °C
		40°C	55°C	65°C	40°C		
High Pressure Sodium	70W	T5	T4A	T4A	T4A		90°C
	100W	T4A	T4A	T4	T4		90°C
	150W	T4	T3C	—	—		90°C
Metal Halide (including pulse start)	70W	T5	T4A	T4A	T4		85°C
	100W	T3C	T3C	—	—		90°C
	150W	T3C	T3B	—	—		90°C
	175W	T3C	T3B	—	—		90°C

Mogul Base Lamp Luminaires:

Maximum Ambient	Watts	Class I, Group B (w/GB suffix) Groups C, D			Class II, Groups E, F, G Class III Simultaneous Presence		Supply Wire °C
		40°C	55°C	65°C	40°C		
High Pressure Sodium	70W	T6	T5	T5	T5		90°C
	100W	T5	T4A	—	T4A		90°C
	150W	T4A	T4	—	T4		90°C
Metal Halide (including pulse start)	70W	T6	T5	T5	T5		85°C
	100W	T5	T4A	T4A	T4A		90°C
	150W	T4	T3C	—	T3C		90°C
	175W	T4	T3C	—	T3C		90°C
	200W	T3C	—	—	—		90°C
	250W	T3C	—	—	—		90°C



4L EVLP Low Profile Hazard•Gard®

Dimensions and Weights

Dimensions In Inches:

	A	B	C	D	E	F
Medium Base	13.92	12.73	16.50	16.71	20.59	19.36
Mogul Base	15.69	14.69	18.25	18.46	22.34	21.30

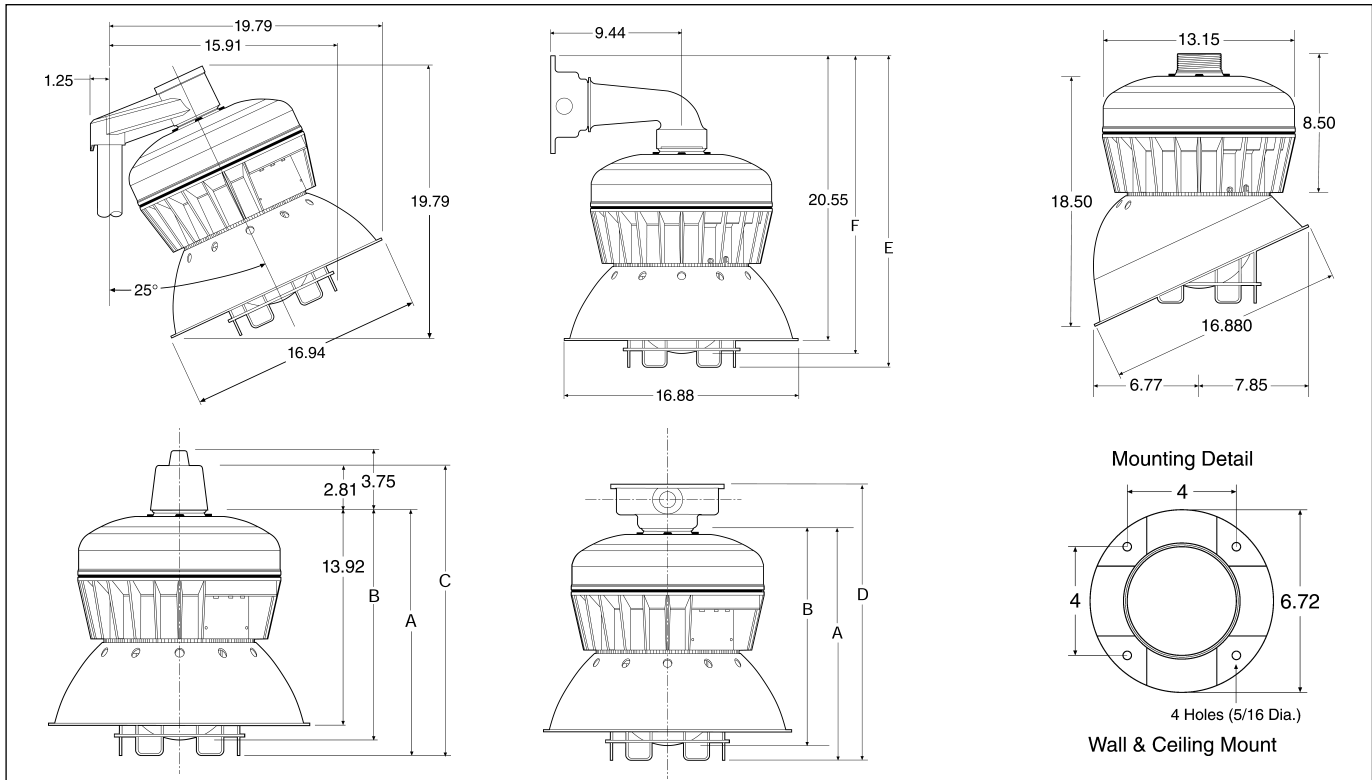

4L Weights (lbs.):

Source	Watts	Luminaire w/guard	
		Medium	Mogul
High Pressure Sodium	70	34	36.5
	100	36	38.5
	150	36.5	39
Metal Halide	70	33.5	36
	100	34.5	37
	150	36	38.5
	175	36	38.5
	200	—	40.5
	250	—	40.5
Add Mounting Modules:		Medium	Mogul
Pendant		1	1
Ceiling		2	2
Bracket		4.5	4.5
Stanchion		2.5	2.5
Add For Reflectors:			
RA739		1	1
RD739		1	1
Deduct for Wire Guard		0.5	0.5

Medium Base

Medium Base

Luminaire with Globe and Guard

EVLPA143151 Lamp: 150W/B17 High Pressure Sodium (HPS)

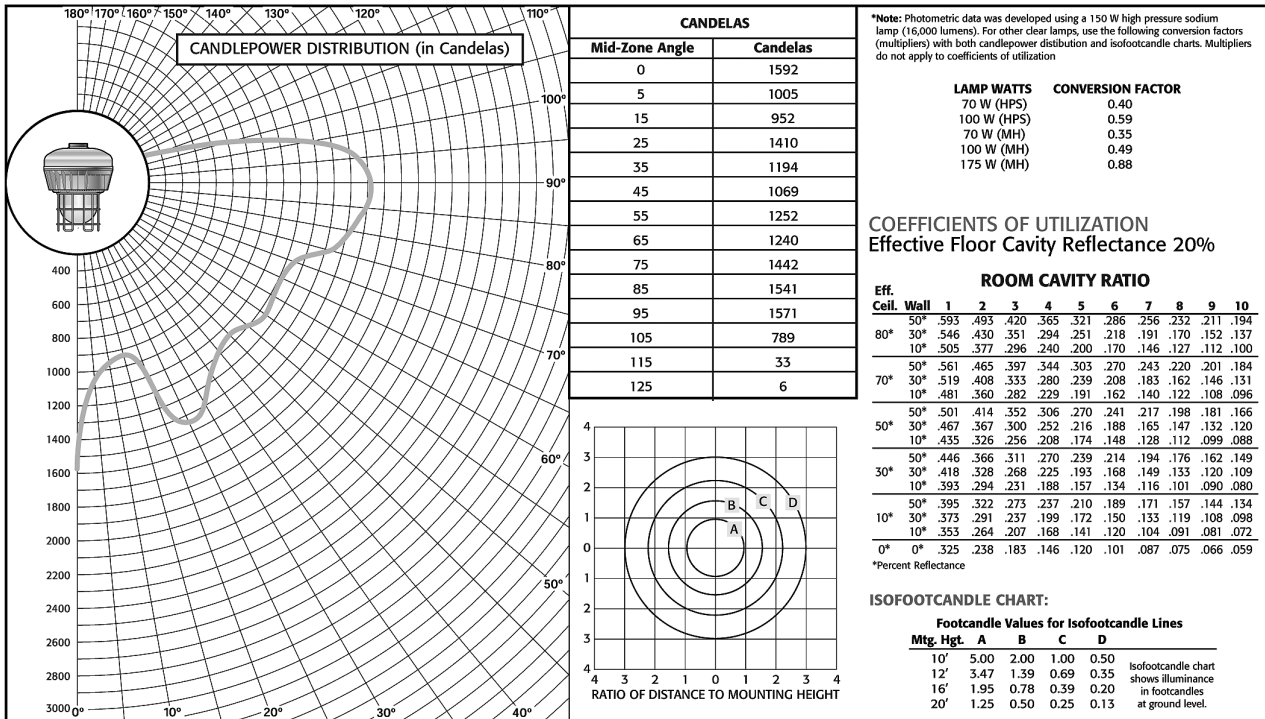

Medium Base

Luminaire with Globe and Dome Reflector (Less Guard)

EVLPA143150RD Lamp: 150W/B17 High Pressure Sodium (HPS)

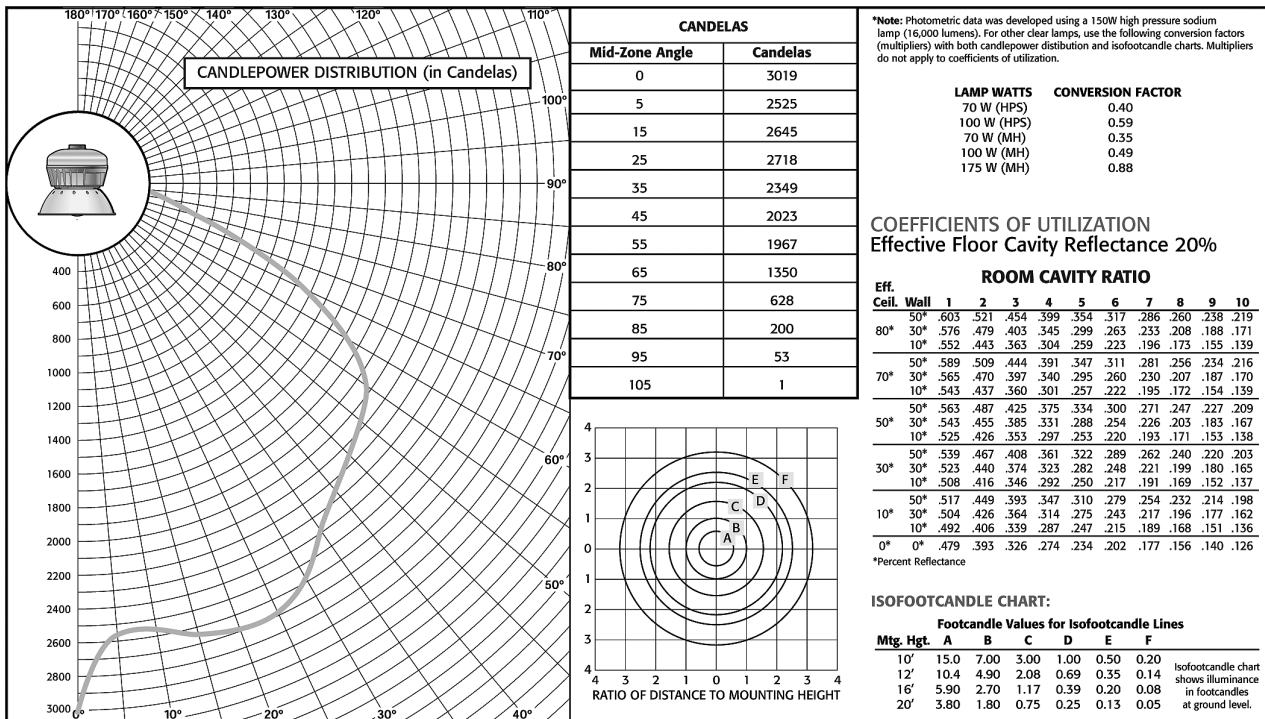

4L

EVLP Low Profile Hazard•Gard®

Photometric Data

Medium and Mogul Base

Medium Base

Luminaire with Globe and 30° Angle Reflector (Less Guard)

EVLP143150RA Lamp: 150W/B17 High Pressure Sodium (HPS)

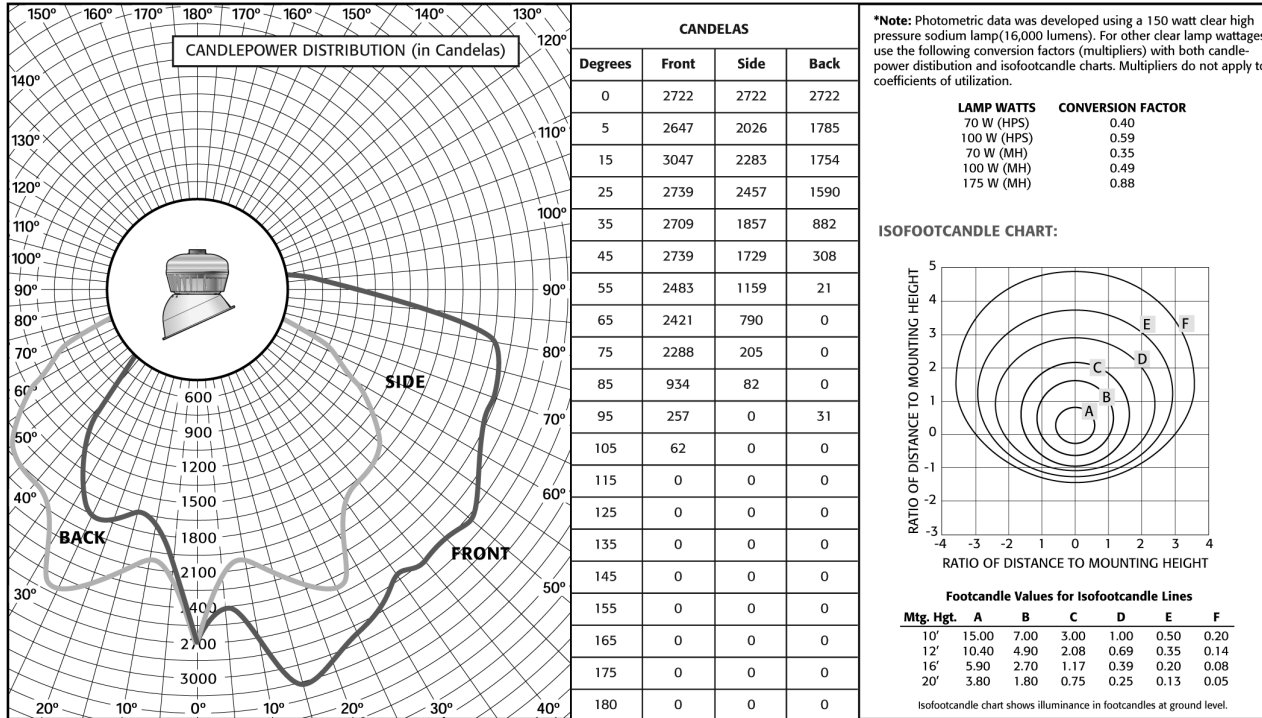

Mogul Base

Luminaire with Globe and Guard

EVLP143151 Lamp: 150W/E23-1/2 High Pressure Sodium (HPS)

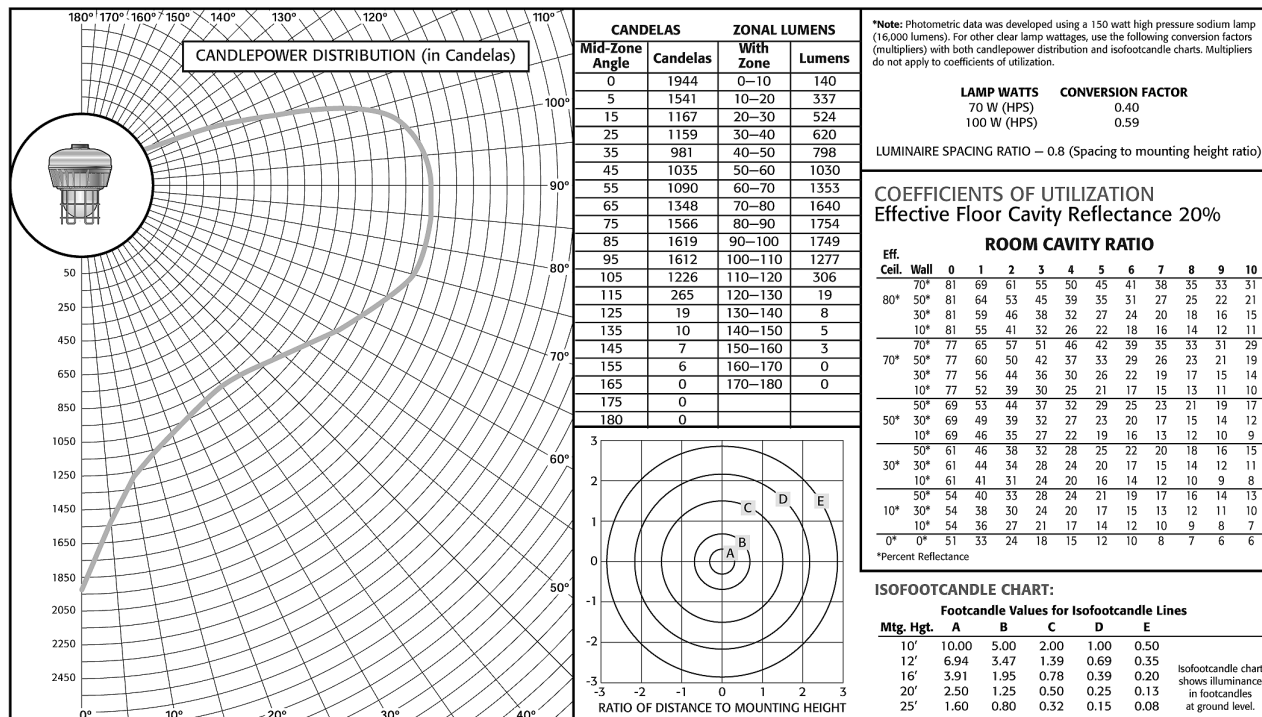

4L

Mogul Base

Mogul Base

Luminaire with Globe and Dome Reflector (Less Guard)

EVLP A043150RD Lamp: 150W/E23-1/2 High Pressure Sodium (HPS)

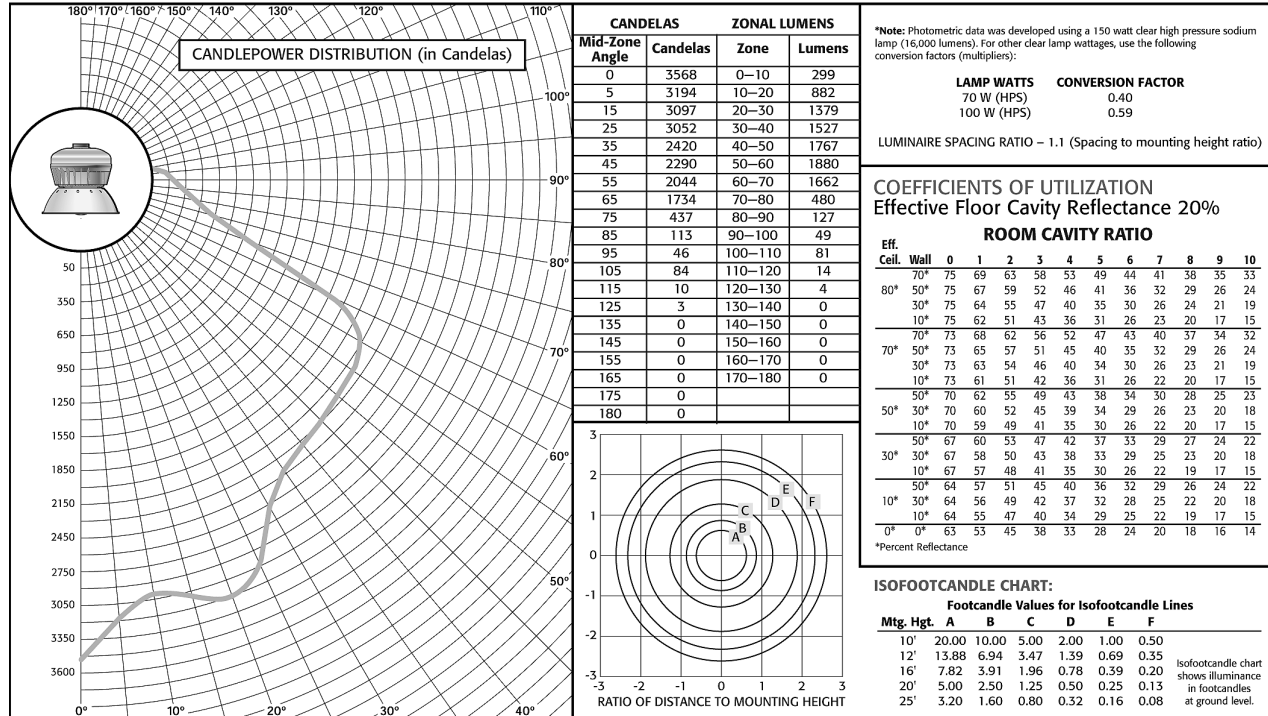

Mogul Base

Luminaire with Globe and 30° Angle Reflector (Less Guard)

EVLP A043150RA Lamp: 150W/E23-1/2 High Pressure Sodium (HPS)

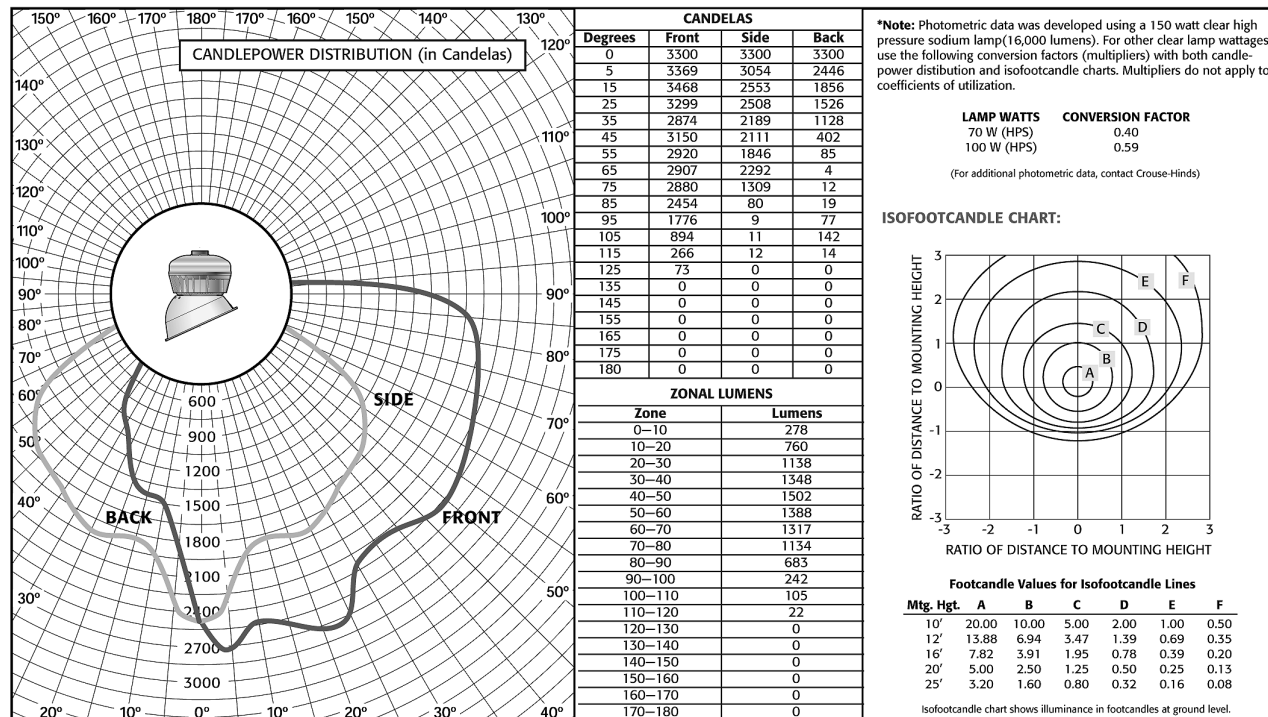

Mogul Base

Mogul Base

Luminaire with Globe and Guard

EVLPA093171 Lamp: 175W/ED28 Metal Halide (MH)

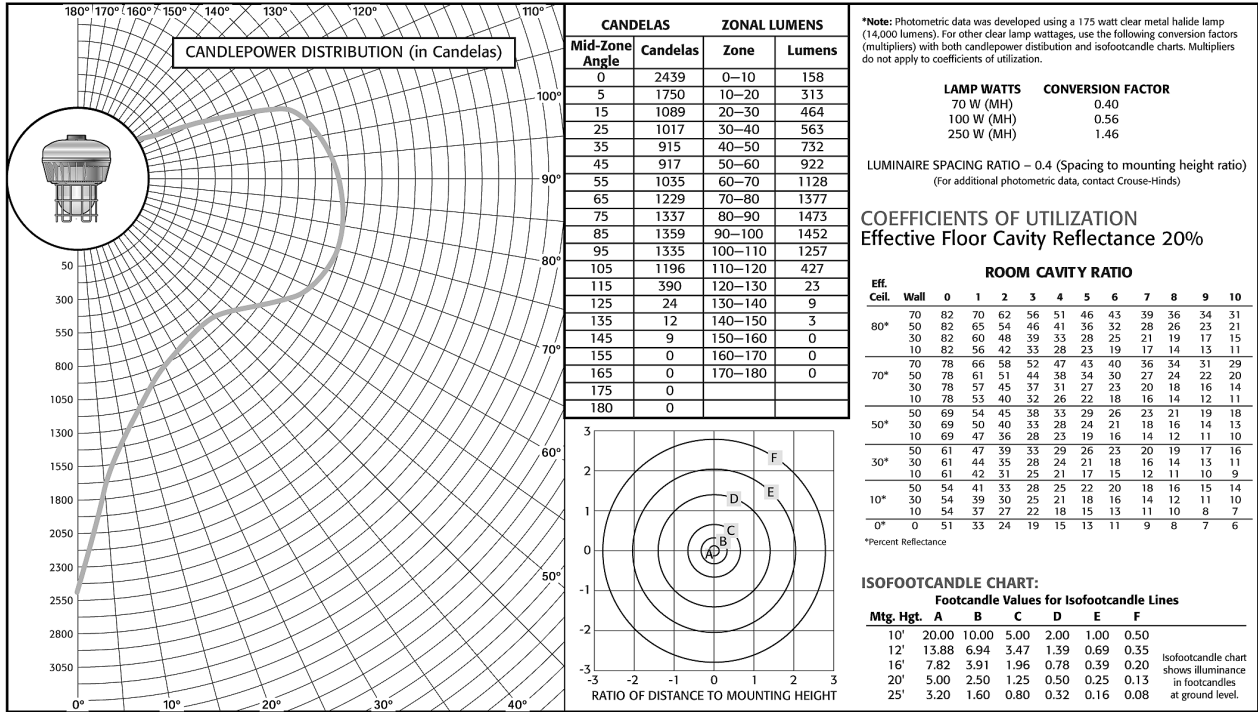

Mogul Base

Luminaire with Globe and Dome Reflector (Less Guard)

EVLPA093170RD Lamp: 175W/ED28 Metal Halide (MH)

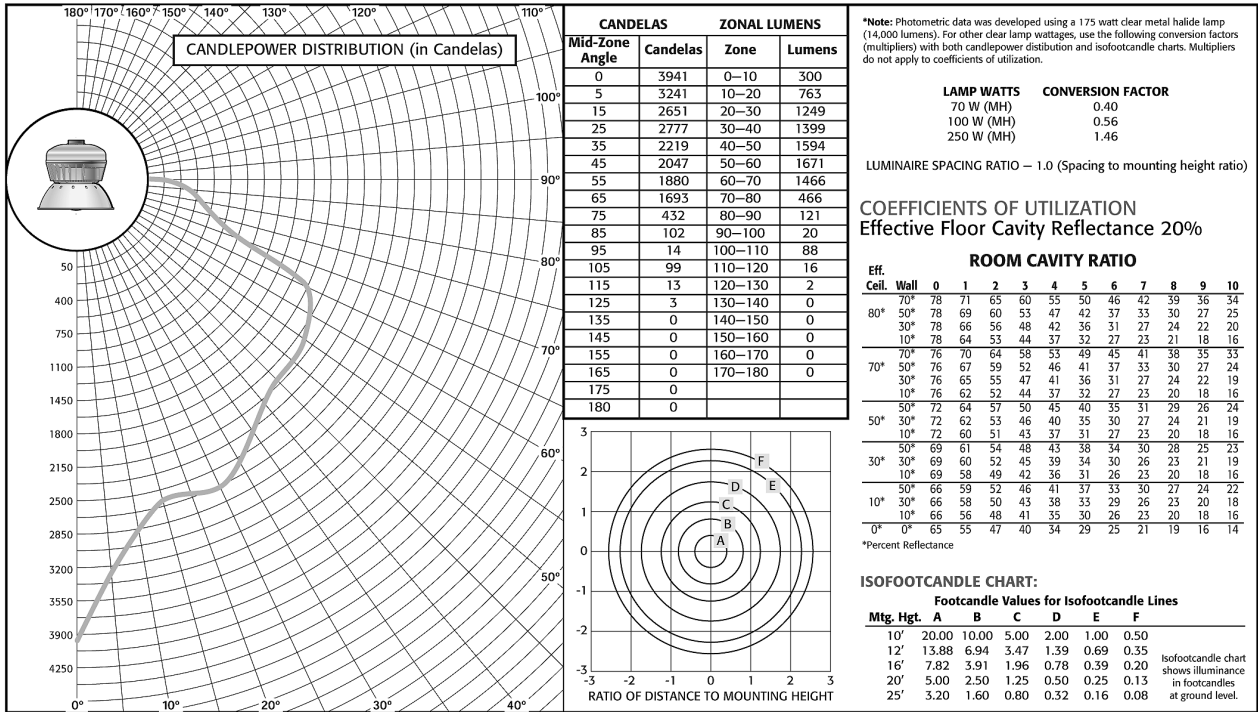

Mogul Base

Mogul Base

Luminaire with Globe and 30° Angle Reflector (Less Guard)

EVLP A093170RA Lamp: 175W/ED28 Metal Halide (MH)

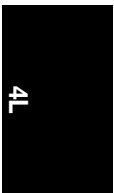
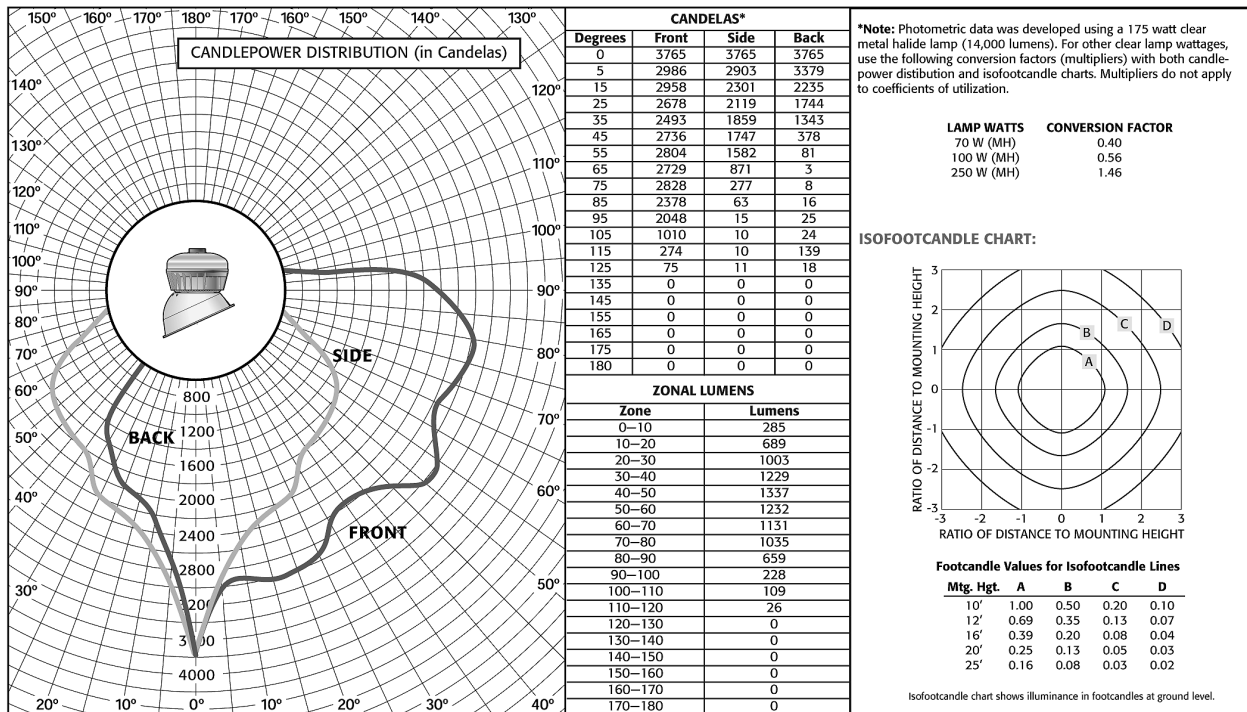

EVM Hazard•Gard® H.I.D. Luminaires

Mogul Base Factory Sealed (Groups C, D)

Cl. I, Div. 1, Groups B (GB suffix), C, D
Cl. I, Zone 1, Groups IIB + H₂
(with suffix – GB), IIB IIA
Cl. II, Div. 1, Groups E, F, G; Class III

Paint Spray
(100W max)
Marine & Wet
Locations
3, 3R, 4, 4X; IP66

Applications:

Hazard•Gard® luminaires are used in:

- Heavy process industries where flammable or explosive vapors, gases or combustible dusts are present
- Hazardous areas, both indoors and outdoors where long life and low maintenance costs are desired
- Petroleum refineries, chemical, petrochemical and other heavy process industry facilities
- Paint spray facilities
- Hazardous locations requiring elevated ambient capability

Features:

- Luminaire is factory wired; power is fed through "wireless" connection block which serves as a mechanical seal between conduit and ballast compartments, eliminating the need for an external, field installed seal. The result is fast, easy installation.
- Dome and 30° angle reflectors made of Krydon® material – won't rust, corrode, dent, chip or peel (order separately – see page 1059).
- High bay reflectors of Alzak® aluminum for high wattage applications.
- Internally fluted glass globes reduce glare and provide comfortable viewing light.
- Wide range of light sources and wattages to meet specific lighting needs – 50 – 400W high pressure sodium (HPS); 70 – 400W metal halide (MH).
- High power factor (90%+) ballasts reduce power costs – allow more luminaires per circuit.
- Four mounting arrangements to suit any lighting layout – pendant, ceiling, wall bracket and stanchion.
- Paint spray booth suitability on 50 to 100 watt luminaires provides efficient, economical H.I.D. lighting for areas where paint residue may accumulate on luminaires.
- Elevated ambient capability permits reliable operation at high ambient temperature. Selected luminaires are suitable for ambient temperature up to 75°C.
- Integral ballasts – separate ballasts are not required. Lowest installed cost.
- Factory sealed, porcelain, mogul base socket.



Certifications and Compliances:

- NEC and CEC:
Class I, Division 1, Groups B (with suffix GB), C, D
Class I, Zone 1, Groups IIB + H₂ (with suffix GB), IIB, IIA
100W max – Paint Spray Suitability
175W max – Class II, Class III
- UL Standards:
844 Hazardous (Classified) Locations
1598 Luminaires
1598A Marine Locations
- CSA Standards:
C22.2 No. 137

Standard Materials:

- Mounting modules, cover, ballast housing, guard, globe ring – copper-free aluminum
- Globe – heat and impact resistant glass
- Exterior hardware – stainless steel
- Lamp socket – porcelain with stainless steel screw shell
- Reflectors – dome and angle: Krydon fiberglass-reinforced polyester material; high bay: Alzak aluminum

Standard Finishes:

- Copper-free aluminum – epoxy powder coat
- Krydon – high reflectance white
- Alzak – natural (anodized)

Options:

Description	Suffix
• Fused – to protect ballast and capacitor against abnormal line conditions. (Not suitable for marine applications).....	S658 †
• Instant restrike – enables a hot HPS lamp to immediately restrike after a momentary loss of arc due to voltage fluctuation or power outage. It has no effect on the warm-up period of a cold lamp (50-150W LX HPS only).	IR*
• Quartz auxiliary lighting – quartz lamp comes to full brightness instantly upon restoration of power to provide emergency illumination during the normal restrike period of the H.I.D. lamp (for use with ED28 lamp). (Quartz lamp not included; use 100 W single-ended lamp – Q100DC, Q100CL/DC, or 100Q/CL/DC.)	QTZ ‡
• Ballast-Gard™ – to eliminate the normally continuous high voltage pulsing in the event of a cycling lamp, inoperative lamp, or no lamp in the socket extending the life of the ballast. (For use with 50-400W HPS lamps.)	BG*
• Group B suitability – luminaires suitable for use in Class I, Group B hazardous (classified) locations.....	GB
• Hazard•Gard® supplied with trunnion arm for floodlighting applications. For use on pendant mount luminaires only. See Floodlight Section	S812

Size Ranges:

- ¾", 1" and 1¼" hubs (see ordering information – see pages 1057–1058)

Electrical Rating Ranges:

- 120, 208, 240, 277, 347, 480, 600, multi-tap*
- 50 to 400 watts

*IR and BG options cannot be used together.
†When ordering fuses for luminaires, option S658, you must specify the operating voltage. S658 cannot be ordered with /MT in the catalog number.
‡Can be used with BG option.
§CSA Certified are not available with multi-tap ballast or S658 fuse option.

Alzak is a registered trademark of ALCOA.

50-400W EVM
Hazard•Gard®
H.I.D. Luminaires
Mogul Base
Factory Sealed (Groups C, D)

Cl. I, Div. 1, Groups B (GB suffix), C, D
 Cl. I, Zone 1, Groups IIB + H₂
 (with suffix GB), IIB, IIA
 Cl. II, Div. 1, Groups E, F, G; Class III

Paint Spray
 (100W max)
 Marine & Wet
 Locations
 3, 3R, 4, 4X; IP66

4L



Watts	Hub Size (In.)	Pendant Luminaires		Wall Bracket Luminaires		Ceiling Luminaires		Stanchion Luminaires (25°)	
		Without Guard Cat. #	With Guard Cat. #	Without Guard Cat. #	With Guard Cat. #	Without Guard Cat. #	With Guard Cat. #	Without Guard Cat. #	With Guard Cat. #
High Pressure Sodium									
50	3/4	EVMA42050	EVMA42051	EVMBX42050	EVMBX42051	EVMCX42050	EVMCX42051		
	1	EVMA43050	EVMA43051	EVMBX43050	EVMBX43051	EVMCX43050	EVMCX43051		
	1 1/4							EVMJ44050	EVMJ44051
70	3/4	EVMA42070	EVMA42071	EVMBX42070	EVMBX42071	EVMCX42070	EVMCX42071		
	1	EVMA43070	EVMA43071	EVMBX43070	EVMBX43071	EVMCX43070	EVMCX43071		
	1 1/4							EVMJ44070	EVMJ44071
100	3/4	EVMA42100	EVMA42101	EVMBX42100	EVMBX42101	EVMCX42100	EVMCX42101		
	1	EVMA43100	EVMA43101	EVMBX43100	EVMBX43101	EVMCX43100	EVMCX43101		
	1 1/4							EVMJ44100	EVMJ44101
150	3/4	EVMA42150	EVMA42151	EVMBX42150	EVMBX42151	EVMCX42150	EVMCX42151		
	1	EVMA43150	EVMA43151	EVMBX43150	EVMBX43151	EVMCX43150	EVMCX43151		
	1 1/4							EVMJ44150	EVMJ44151
200	3/4	EVMA42200	EVMA42201	EVMBX42200	EVMBX42201	EVMCX42200	EVMCX42201		
	1	EVMA43200	EVMA43201	EVMBX43200	EVMBX43201	EVMCX43200	EVMCX43201		
	1 1/4							EVMJ44200	EVMJ44201
250	3/4	EVMA42250	EVMA42251	EVMBX42250	EVMBX42251	EVMCX42250	EVMCX42251		
	1	EVMA43250	EVMA43251	EVMBX43250	EVMBX43251	EVMCX43250	EVMCX43251		
	1 1/4							EVMJ44250	EVMJ44251
400	3/4	EVMA42400	EVMA42401	EVMBX42400	EVMBX42401	EVMCX42400	EVMCX42401		
	1	EVMA43400	EVMA43401	EVMBX43400	EVMBX43401	EVMCX43400	EVMCX43401		
	1 1/4							EVMJ44400	EVMJ44401

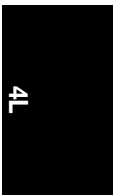

Complete the Catalog Number by Adding Voltage and Options Suffixes as Follows:

		NEC/UL			CEC/CSA (cUL)				
1.	Voltage Suffix	Multi Tap /MT	120V /120	480V /480	Tri Tap /TT	120V /120			
		CEC/CSA (cUL)- CWI Isolated Ballasts			EXPORT				
	Voltage Suffix	208V CWI /208CWI	240V CWI /240CWI	480V CWI /480CWI	600V CWI /600CWI	220V 60Hz /220	220V 50Hz /220 50	230V 50Hz /230 50	240V 50Hz /240 50

- 2. 150W HPS Luminaires, 55V Lamps is Standard, for 100V lamps - Add suffix "CE"
- 3. Options - Add the Required Options Suffixes, see page 1056, in alpha-numeric order.

4L

**70-400W EVM
Hazard•Gard®
H.I.D Luminaires
Factory Sealed (Groups C, D)**

Cl. I, Div. 1, Groups B
(GB suffix), C, D
Cl. I, Zone 1, Groups IIB + H₂
(with suffix GB), IIB, IIA
Cl. II, Div. 1, Groups E, F, G;
Class III

Paint Spray (100W max.)
Marine & Wet Locations
3, 3R, 4, 4X; IP66



Pendant Luminaires Wall Bracket Luminaires Ceiling Luminaires Stanchion Luminaires (25°)

Watts	Hub Size (In.)	Without Guard Cat. #	With Guard Cat. #	Without Guard Cat. #	With Guard Cat. #	Without Guard Cat. #	With Guard Cat. #	Without Guard Cat. #	With Guard Cat. #
Pulse Start Metal Halide									
150	¾	EVMA92150 S828	EVMA92151 S828	EVMBX92150 S828	EVMBX92151 S828	EVMCX92150 S828	EVMCX92151 S828		
	1	EVMA93150 S828	EVMA93151 S828	EVMBX93150 S828	EVMBX93151 S828	EVMCX93150 S828	EVMCX93151 S828		
	1¼							EVMJ94150 S828	EVMJ94151 S828
175	¾	EVMA92170 S828	EVMA92171 S828	EVMBX92170 S828	EVMBX92171 S828	EVMCX92170 S828	EVMCX92171 S828		
	1	EVMA93170 S828	EVMA93171 S828	EVMBX93170 S828	EVMBX93171 S828	EVMCX93170 S828	EVMCX93171 S828		
	1¼							EVMJ94170 S828	EVMJ94171 S828
200	¾	EVMA92200 S828	EVMA92201 S828	EVMBX92200 S828	EVMBX92201 S828	EVMCX92200 S828	EVMCX92201 S828		
	1	EVMA93200 S828	EVMA93201 S828	EVMBX93200 S828	EVMBX93201 S828	EVMCX93200 S828	EVMCX93201 S828		
	1¼							EVMJ94200 S828	EVMJ94201 S828
250	¾	EVMA92250 S828	EVMA92251 S828	EVMBX92250 S828	EVMBX92251 S828	EVMCX92250 S828	EVMCX92251 S828		
	1	EVMA93250 S828	EVMA93251 S828	EVMBX93250 S828	EVMBX93251 S828	EVMCX93250 S828	EVMCX93251 S828		
	1¼							EVMJ94250 S828	EVMJ94251 S828
320	¾	EVMA92320 S828	EVMA92321 S828	EVMBX92320 S828	EVMBX92321 S828	EVMCX92320 S828	EVMCX92321 S828		
	1	EVMA93320 S828	EVMA93321 S828	EVMBX93320 S828	EVMBX93321 S828	EVMCX93320 S828	EVMCX93321 S828		
	1¼							EVMJ94320 S828	EVMJ94321 S828
400	¾	EVMA92400 S828	EVMA92401 S828	EVMBX92400 S828	EVMBX92401 S828	EVMCX92400 S828	EVMCX92401 S828		
	1	EVMA93400 S828	EVMA93401 S828	EVMBX93400 S828	EVMBX93401 S828	EVMCX93400 S828	EVMCX93401 S828		
	1¼							EVMJ94400 S828	EVMJ94401 S828

Metal Halide

70	¾	EVMA92070	EVMA92071	EVMBX92070	EVMBX92071	EVMCX92070	EVMCX92071		
	1	EVMA93070	EVMA93071	EVMBX93070	EVMBX93071	EVMCX93070	EVMCX93071		
	1¼							EVMJ94070	EVMJ94071
100	¾	EVMA92100	EVMA92101	EVMBX92100	EVMBX92101	EVMCX92100	EVMCX92101		
	1	EVMA93100	EVMA93101	EVMBX93100	EVMBX93101	EVMCX93100	EVMCX93101		
	1¼							EVMJ94100	EVMJ94101
175	¾	EVMA92170	EVMA92171	EVMBX92170	EVMBX92171	EVMCX92170	EVMCX92171		
	1	EVMA93170	EVMA93171	EVMBX93170	EVMBX93171	EVMCX93170	EVMCX93171		
	1¼							EVMJ94170	EVMJ94171
250	¾	EVMA92250	EVMA92251	EVMBX92250	EVMBX92251	EVMCX92250	EVMCX92251		
	1	EVMA93250	EVMA93251	EVMBX93250	EVMBX93251	EVMCX93250	EVMCX93251		
	1¼							EVMJ94250	EVMJ94251
400	¾	EVMA92400	EVMA92401	EVMBX92400	EVMBX92401	EVMCX92400	EVMCX92401		
	1	EVMA93400	EVMA93401	EVMBX93400	EVMBX93401	EVMCX93400	EVMCX93401		
	1¼							EVMJ94400	EVMJ94401

Complete the Catalog Number by Adding Voltage and Options Suffixes as Follows:

Standard Voltage Ballasts – 60Hz

Voltage Suffix	NEC/UL				CEC/CSA (cUL)		
	Multi Tap /MT	Dual-Tap /DT	120V /120	480V /480	Tri Tap /TT	Dual-Tap /DT	120V /120

Optional Voltage Ballasts – 50 or 60Hz

Voltage Suffix	*CEC/CSA (cUL)- CWI Isolated Ballasts					EXPORT		
	208V CWI /208CWI	240V CWI /240CWI	600V CWI /600CWI	220V 60Hz /220	220V 50Hz /220 50	230V 50Hz /230 50	240V 50Hz /240 50	

- 150W HPS Luminaires, 55V Lamps is Standard, for 100V lamps - Add suffix *CE*
- Options - Add the Required Options Suffixes, see page 1056, in alpha-numeric order.

*CWI Isolated Ballasts are only available for 175W-400W metal halide (non pulse start) luminaires.

4L

Reflectors



Dome



30° Angle

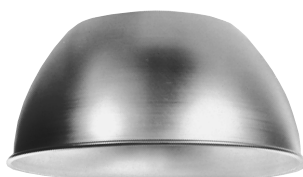

High Bay

Type	Cat. #
Dome	RD739
30° Angle	RA739
High Bay	EV3912

Temperature Performance Data
Maximum Ambient

Watts	Class I				Class II (E, F, G)	Simultaneous Presence	Paint Spray Booth	Supply Wire
	40°C	55°C	65°C	75°C	40°C	40°C	40°C	°C
High Pressure Sodium								
50	T6	T6	T6	T5	T4	T4	T4A	90
70	T6	T6	T5	T4A	T4	T4	T4A	90
100	T5	T5	T4A	T4A	T4	T4	T4A	90
150	T4A	T4A	T4	—	T3C	T3C	—	90
200	T4A	T4A	T4	—	—	—	—	90
250	T4	T3C	—	—	—	—	—	90
400	T3C	—	—	—	—	—	—	90
Metal Halide (Including Pulse Start)								
70	T6	T6	—	T3	T3C	T3C	T4A	90
100	T5	T5	T4A	T3	T3C	T3C	T4A	90
150	T4A	T4	T4	—	T3C	T3C	—	90
175	T4A	T4	T4	—	T3C	T3C	—	90
200	T4	T3C	—	—	—	—	—	90
250	T4	T3C	—	—	—	—	—	90
320	T3A	—	—	—	—	—	—	90
400	T3A	—	—	—	—	—	—	90

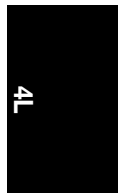

4L EVM Hazard•Gard® H.I.D. Luminaires

Dimensions and Weights

Dimensions:

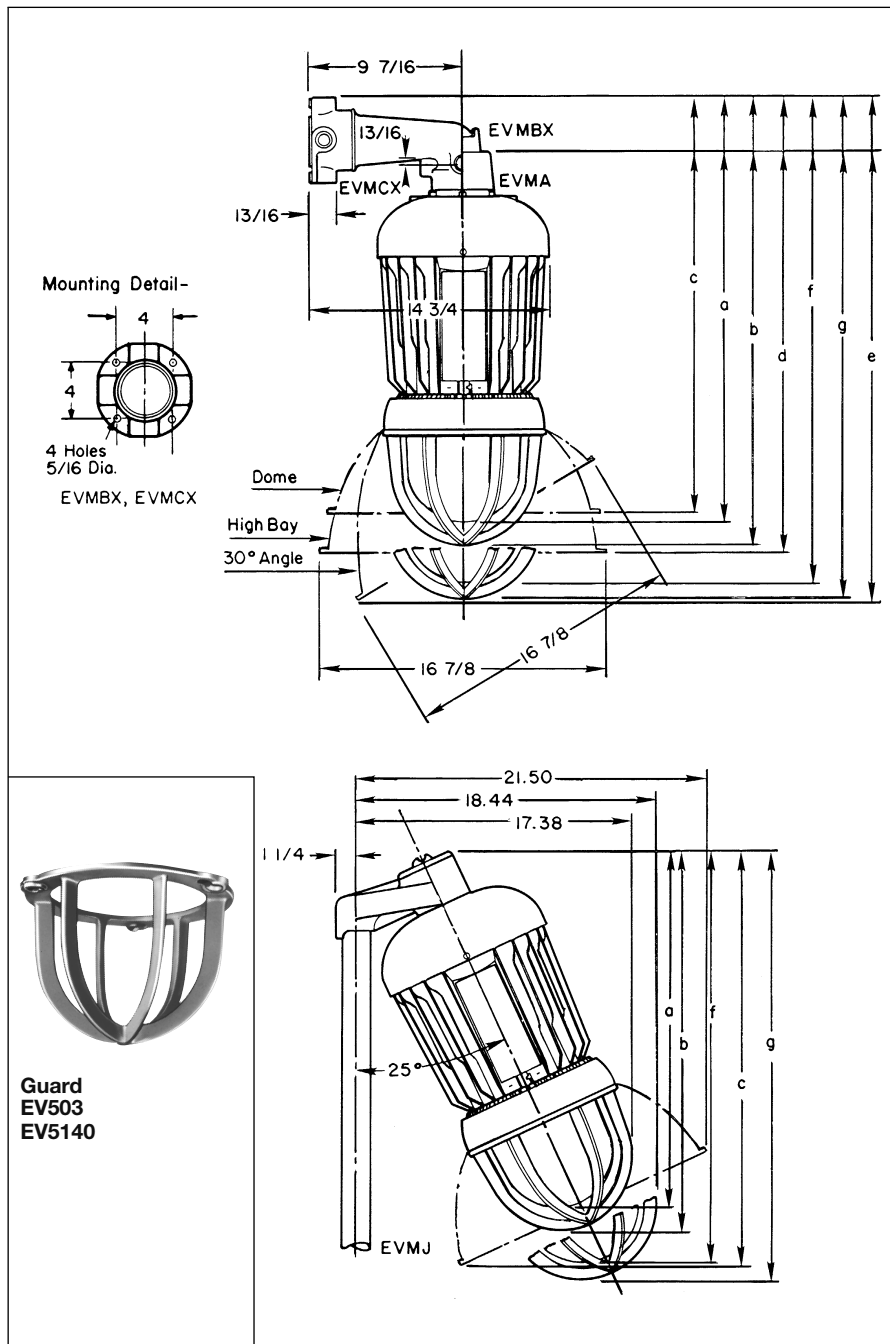

Luminaire Net Weights:

H.I.D. Source	Lamp Watts	Luminaire Only with Globe and Guard (lbs.)
High Pressure Sodium	50	40
	70	40
	100	44
	150 (55V)	45
	150 (100V)	44
	200	46
Metal Halide	250	46
	400	55
	70	39
Metal Halide	100	39
	175	42
	250	43
400	51	

Type	Lbs.	Type	Lbs.
Add for Mounting Modules:			
Pendant	1	Bracket	4 1/4
Ceiling	2	Stanchion	2 1/4

Add for Reflectors:			
RD739	1 3/4		
RA739	2		
EV3912	2 1/2		
Deduct: 1 1/2 lbs. for luminaire without guard.			

4L



Guard
EV503
EV5140

100, 175, 250W MV 50, 70, 100, 150W HPS 70, 100, 175, 250W MH
All luminaires with QTZ option and 200, 250, 400W HPS 400W MV & MH

All - Reflectors

Type	a	b	f	g	Dome - c	High Bay - d	30° Angle - e
EVMA	25 1/16	26	27 5/16	28 1/4	23 7/8	26 7/16	28 9/16
EVMBX	27 7/8	28 13/16	30 1/8	31 1/16	26 11/16	29 3/4	31 3/8
EVMCX	24	24 15/16	26 1/4	27 3/16	22 13/16	25 3/8	27 1/2
EVMJ	22 11/16	24 1/8	25 1/4	26 1/8	25 3/8	27 11/16	28 3/4

**Lamp: 150W/E-23-1/2 high pressure sodium (HPS)
Total bare lamp lumens: 16,000**

Luminaire With Globe and Without Guard

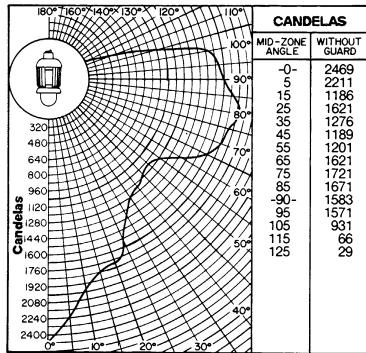

Note: Photometric data was developed using a 150 watt clear high pressure sodium lamp (16,000 lumens). For other clear lamps, use the following conversion factors (multipliers): 50W HPS – .25; 70W HPS – .40; 100W HPS – .59. Multipliers are for use with candela curve only.

Luminaire spacing ratio is 0.80.

Coefficient of Utilization

Effective Floor Cavity Reflectance 20%

% Reflectance Eff. Ceil.	Wall	Room Cavity Ratio				
		1	2	3	4	5
80	50	.695	.579	.494	.410	.382
	30	.644	.509	.417	.326	.305
	10	.599	.450	.356	.262	.246
70	50	.659	.549	.469	.387	.363
	30	.613	.484	.397	.311	.291
	10	.570	.431	.341	.251	.236
50	50	.592	.491	.419	.344	.327
	30	.555	.439	.360	.279	.265
	10	.522	.393	.312	.229	.218
30	50	.531	.438	.373	.304	.292
	30	.502	.396	.325	.250	.240
	10	.474	.358	.284	.207	.200
10	50	.476	.390	.331	.267	.260
	30	.451	.355	.291	.222	.217
	10	.429	.325	.257	.184	.181
0	0	.399	.295	.230	.159	.159
% Reflectance Eff. Ceil.	Wall	Room Cavity Ratio				
		6	7	8	9	10
80	50	.342	.306	.278	.265	.233
	30	.266	.234	.209	.198	.168
	10	.212	.184	.160	.153	.127
70	50	.324	.292	.265	.253	.222
	30	.254	.223	.201	.191	.163
	10	.202	.176	.155	.149	.123
50	50	.292	.263	.240	.231	.203
	30	.232	.203	.184	.177	.150
	10	.187	.162	.143	.139	.114
30	50	.262	.236	.218	.210	.185
	30	.211	.186	.167	.162	.138
	10	.172	.148	.132	.129	.105
10	50	.234	.213	.195	.191	.167
	30	.190	.169	.152	.149	.125
	10	.156	.135	.121	.118	.096
0	0	.135	.116	.103	.103	.081



**Lamp: 150W/E-23-1/2 high pressure sodium (HPS)
Total bare lamp lumens: 16000**

Luminaire With Globe, Hi-Bay Reflector and Without Guard

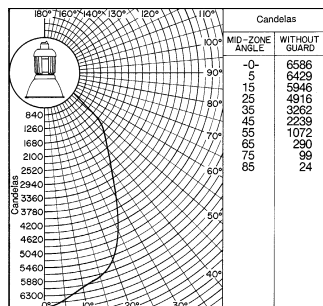

Note: Photometric data was developed using a 150 watt clear high pressure sodium lamp (16,000 lumens). For other clear lamps, use the following conversion factors (multipliers): 50W HPS - .25; 70W HPS - .40; 100W HPS - .59. Multipliers are for use with candela curve only.

Luminaire spacing ratio is 1.00.

**Lamp: 150W/E-23-1/2 high pressure sodium (HPS)
Total bare lamp lumens: 16000**

Luminaire With Globe, Dome Reflector and Without Guard

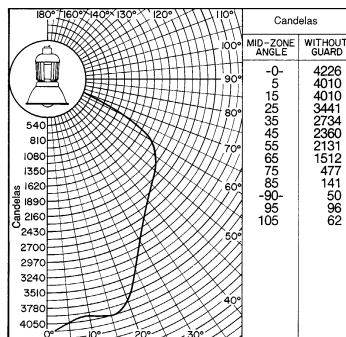

Note: Photometric data was developed using a 150 watt clear high pressure sodium lamp (16,000 lumens). For other clear lamps, use the following conversion factors (multipliers): 50W HPS - .25; 70W HPS - .40; 100W HPS - .59. Multipliers are for use with candela curve only.

Luminaire spacing ratio is 1.20.

Coefficient of Utilization

Effective Floor Cavity Reflectance 20%

% Reflectance	% Reflectance		Room Cavity Ratio				
	Eff. Ceil.	Wall	1	2	3	4	5
80	50		.668	.618	.573	.531	.494
	30		.651	.592	.542	.495	.455
	10		.636	.569	.517	.468	.427
70	50		.655	.608	.566	.525	.487
	30		.639	.583	.536	.491	.452
	10		.625	.564	.513	.464	.425
50	50		.629	.587	.550	.511	.476
	30		.616	.568	.525	.482	.446
	10		.606	.550	.505	.459	.422
30	50		.606	.569	.535	.498	.466
	30		.597	.554	.514	.474	.438
	10		.588	.539	.497	.454	.418
10	50		.586	.553	.522	.487	.457
	30		.578	.539	.504	.466	.433
	10		.570	.528	.489	.449	.413
0	0		.560	.517	.479	.439	.404
% Reflectance	% Reflectance		Room Cavity Ratio				
	Eff. Ceil.	Wall	6	7	8	9	10
80	50		.460	.427	.396	.369	.328
	30		.420	.388	.358	.330	.288
	10		.394	.361	.330	.303	.262
70	50		.455	.423	.392	.366	.325
	30		.418	.385	.356	.328	.288
	10		.391	.359	.329	.303	.262
50	50		.444	.414	.385	.360	.320
	30		.412	.380	.352	.325	.285
	10		.388	.357	.328	.301	.261
30	50		.436	.406	.379	.354	.315
	30		.407	.377	.348	.322	.282
	10		.385	.354	.326	.300	.259
10	50		.428	.400	.373	.348	.311
	30		.402	.373	.345	.319	.280
	10		.382	.352	.324	.298	.258
0	0		.373	.343	.315	.290	.249

Coefficient of Utilization

Effective Floor Cavity Reflectance 20%

% Reflectance	% Reflectance		Room Cavity Ratio				
	Eff. Ceil.	Wall	1	2	3	4	5
80	50		.716	.637	.568	.507	.455
	30		.689	.596	.519	.452	.398
	10		.666	.561	.480	.410	.355
70	50		.700	.624	.559	.498	.446
	30		.675	.585	.512	.447	.393
	10		.653	.555	.476	.407	.353
50	50		.668	.598	.538	.479	.432
	30		.648	.567	.498	.435	.385
	10		.631	.539	.466	.400	.349
30	50		.640	.575	.518	.463	.417
	30		.625	.549	.485	.425	.376
	10		.610	.526	.457	.394	.344
10	50		.615	.554	.500	.447	.404
	30		.602	.532	.472	.415	.369
	10		.590	.513	.448	.388	.339
0	0		.575	.498	.434	.373	.326
% Reflectance	% Reflectance		Room Cavity Ratio				
	Eff. Ceil.	Wall	6	7	8	9	10
80	50		.413	.373	.339	.312	.275
	30		.355	.318	.285	.258	.222
	10		.316	.280	.246	.221	.187
70	50		.405	.368	.334	.308	.271
	30		.352	.314	.283	.256	.222
	10		.312	.277	.245	.221	.187
50	50		.392	.356	.324	.299	.264
	30		.345	.307	.277	.252	.217
	10		.309	.274	.243	.219	.185
30	50		.380	.345	.316	.291	.257
	30		.338	.303	.272	.247	.214
	10		.306	.270	.241	.217	.183
10	50		.369	.337	.307	.283	.251
	30		.331	.298	.267	.244	.210
	10		.301	.267	.238	.215	.181
0	0		.289	.255	.226	.203	.170

4L

Description	Page No.
Application/Selection	see page 1064
General Purpose Luminaires	
VF Vaporgard™ Series	see page 1065
Non-metallic Luminaires	
NFL Series	see pages 1096–1098
N2MVF	see pages 1078–1082
Hazardous Area Luminaires	
CPMVF	see pages 1068–1069
DMVF	see pages 1071–1077
eLLB20 Series	see pages 1109–1111
eLLK Series	see pages 1099–1102
EVLPF	see pages 1083–1088
EVF Series	see page 1112
EVFDR Series	see pages 1116–1117
EVFT Illuminator™ Series	see pages 1092–1095
FVN Series	see pages 1106–1108
FVS Series	see pages 1089–1091
nLLK Series	see pages 1103–1105
VMVF	see page 1070



5L Fluorescent Lighting Luminaires

Hazardous and Non-hazardous Application and Selection Quick Selector Chart

Applications:

- For use in hazardous or non-hazardous areas (as shown in the Quick Selector Chart below)
- Low operating cost
- High light output per watt
- Low brightness
- Low glare
- Uniform light
- Instant illumination

Considerations for Selection:

Having made the determination that a fluorescent luminaire is required, the remaining selection is the type of luminaire (i.e., number and kind of lamps) and placement of luminaire. To determine the number of luminaires:

1. Determine Cavity Ratios for room, ceiling and floor
2. Determine Coefficient of Utilization
3. Determine Light Loss
4. Determine Lamp Lumens required = $\frac{\text{Footcandles} \times \text{Area}}{\text{Coefficient of Utilization} \times \text{Light Loss Factor}}$
5. Determine number of luminaires required = $\frac{\text{Total Lamp Lumens Required}}{\text{Lamp Lumens per Luminaire}}$

Table 500.8(C) Identification Numbers

Maximum Temperature		Temp. Class (T Code)
Deg. C	Deg. F	
450	842	T1
300	572	T2
280	536	T2A
260	500	T2B
230	446	T2C
215	419	T2D
200	392	T3
180	356	T3A
165	329	T3B
160	320	T3C
135	275	T4
120	248	T4A
100	212	T5
85	185	T6

Quick Selector Chart

Series	NEC – Hazardous Area Compliance	Lamp Watts	Volts	No. of Lamps
VF	Cl. I, Division 2, Groups A, B, C, D	9	120	2
NFL	Cl. I, Division 2, Groups A, B, C, D	32, 40	120–277V 50–60Hz	1, 2
FVN	Cl. I, Division 2, Groups A, B, C, D; Cl. II, Groups F, G; Cl. III	32, 40, 60	120, 277, 220 / 240 50 or 60Hz	2, 3
EVF	Cl. I, Groups C, D; Cl. II, Groups E, F, G	32, 40, 60, 110	120, 277, 347, 220 / 240 50 or 60Hz	1, 2, 3, 4
EVFDR	Cl. I, Groups C, D; Cl. II, Groups E, F, G	32, 40, 60, 110	120, 277, 220 / 240 50 or 60Hz	2
EVFT	Cl. I, Groups B, C, D; Cl. II, Groups E, F, G; Cl. III	39	120, 277, 220 / 240 50 or 60Hz	2, 4
FVS	Cl. I, Division 2, Groups B, C, D; Cl. II, Groups E, F, G; Cl. III	40	120–277V, 50–60Hz or 347V, 60Hz	2
DMVF	Cl. I, Division 2, Groups A, B, C, D; Cl. II, Groups E, F, G; Cl. III; Simultaneous Presence	26, 32, 42	120–277V, 50–60Hz or 347V, 60Hz	2, 3
N2MVF	Cl. I, Division 2, Groups A, B, C, D; Class II, Groups F, G; Class III; Simultaneous Presence	26, 32	120–277V, 50–60Hz or 347V, 60Hz	2
EVLP	Cl. I, Division 1, Groups (B), C, D; Cl. II, Groups E, F, G; Cl. III; Simultaneous Presence	26, 32	120–277V, 50–60Hz or 347V, 60Hz	2
CPMVF	Cl. I, Division 2, Groups A, B, C, D	26, 32, 42	120–277V, 50–60Hz or 347V, 60Hz	2
eLLB 20	Cl. I, Division 2, Groups A, B, C, D; Cl. I, Zone 1, Group IIC; Cl. II, Division 2, Groups F, G	17, 32	120–240V, 50–60Hz 110–230VDC	2
eLLK	Cl. I, Zone 1 & Division 2; Cl. II, Division 2	32	120–254V	2
nLLK	Cl. I, Division 2, Groups A, B, C, D; Cl. I, Zone 2 AEx nA II; Cl. II, Division 2, Groups F, G	17, 32	120–277V, 60Hz	2

5L

VF Series Vaporgard™ Fluorescent Luminaires

Cl. I, Div. 2, Groups A, B, C, D*
Cl. I, Zone 2 IIC*
Wet Locations
3, 3R

5L

Applications:

VF Series *Vaporgard* Fluorescent Lighting Luminaires are used:

- Indoors or outdoors in industrial locations where enclosed and gasketed luminaires are required
- Where the energy efficiency and long life of single twin tube compact fluorescent lamps are desired
- Where luminaires may be subject to wet, damp, dirty locations
- Where vibration and rough usage are a problem
- To retrofit existing *Vaporgard* incandescent luminaires
- In tunnels, building entrances, utility rooms, hallways and similar locations
- With clear or colored globes to illuminate or mark critical locations or processes

Features:

- Compact size and light weight allow adaptation and easy installation in many industrial applications
- Cast copper-free aluminum (less than 0.4 of 1% copper) construction and epoxy powder finish provide excellent resistance to corrosion
- Variety of mounting arrangements to suit any lighting layout – pendant, ceiling, wall bracket, angle stanchion, through feed, box mount
- VFH luminaire components can be installed on existing *Vaporgard* incandescent components and standard stamped metal boxes
- Fixtures available for use with two compact 9 watt fluorescent lamps
- Dome and 30° angle reflectors made of bright white *Krydon*® material provide superior reflectivity; will not chip, peel, dent, rust, or corrode (order separately – see pages 1066–1067)
- Glass globes are internally fluted and stippled to reduce glare and provide even light distribution; exteriors are smooth to shed dust
- **All luminaires 120 VAC only!**
- Grounding wire for safety

Certifications and Compliances:

- UL Standard: 1598, 844
- CSA Standard: C22.2 No. 137

Standard Materials:

- Bodies and guards – copper-free aluminum (less than 0.4 of 1%)
- Globes – clear or colored, glass or plastic
- Reflectors – *Krydon* fiberglass-reinforced polyester material



Accessories:

- See next page for complete listing

Luminaire Net Weights:

Fixture Type	1-Lamp Luminaire With Globe & Guard (lbs.)	2-Lamp Luminaire With Globe & Guard (lbs.)
VFA	4 ³ / ₄	5
VFHF	5	5 ¹ / ₄
VFHBF	7 ¹ / ₄	7 ¹ / ₂

Type	Lbs.	Type	Lbs.
------	------	------	------

Add for Reflectors:

Dome	1	30° Angle	1
------	---	-----------	---

Deduct: ½ lb. for P21 Guard

Temperature Performance Data:

Lamp	Class I, Div. 2	Max. Ambient	Supply Wire °C	Minimum Operating °C (25°F)
9W	T3B	40°C	75°C	-4°C (25°F)

Standard Finishes:

- Copper-free aluminum – powder epoxy finish
- *Krydon* material – high reflectance white

Electrical Ratings:

- Input voltage – 120 VAC, 60 hertz
- Wattages: two 9 watt lamps

Dimensions

In Inches:

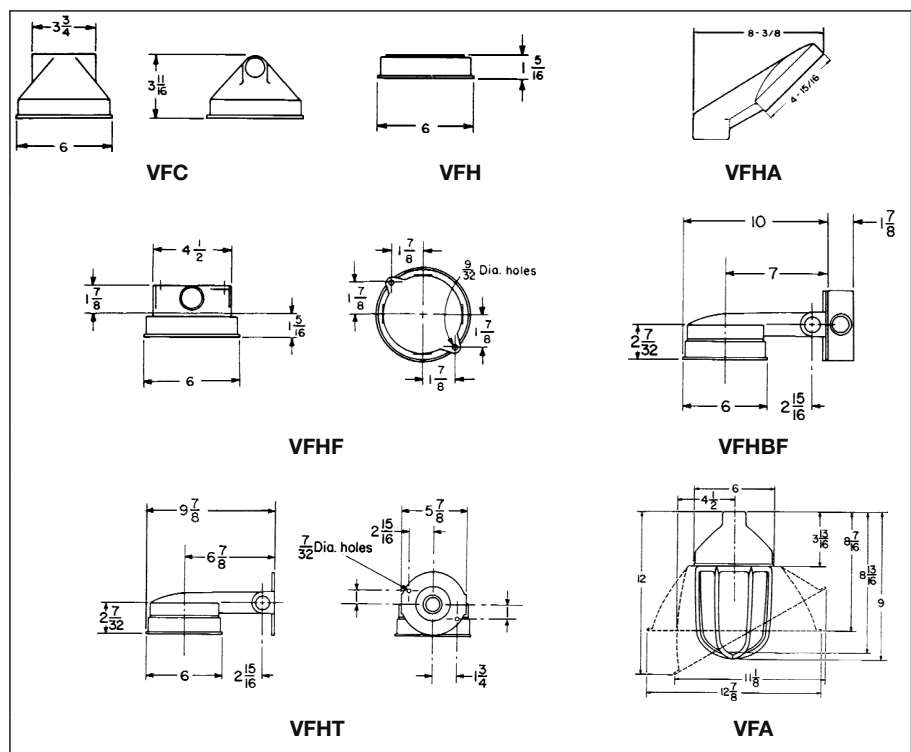

*All mountings except stanchion.

5L

**VF Series Vaporgard™
Fluorescent Luminaires**

Cl. I, Div. 2, Groups A, B, C, D†
Cl. I, Zone 2 IIC†
Wet Locations
NEMA 3, 3R

Twin Tube Fluorescent with G24 Clear Glass Globe and P21 Guard (lamps not included)



Luminaire Watts	Hub Size (In.)	Pendant Mount Cat. #	Ceiling Mount Cat. #	Wall Mount (w/Box) Cat. #	Wall Mount (No Box) Cat. #	Angle Stanchion Mount* Cat. #	Through Feed Mount Cat. #	Box Mount & Retrofit Cat. #
2 Lamps, 9W Each	1/2	VFA122GP	VFHF122GP	VFHBF122GP	VFHT122GP		VFC122GP	VFH122GP
	3/4	VFA222GP	VFHF222GP	VFHBF222GP	VFHT222GP		VFC222GP	
	1	VFA322GP						
	1 1/4					VFHA422GP		

VF Series with Colored Glass Globes or Plastic Globes

To obtain:

- Substitute appropriate globe designation for "G" in above Cat. Nos.

Accessories and Components
Reflectors



Type	Cat. #
Dome (Cannot be used with wall mount luminaires)	RD71
30° Angle	RA71

Globes



Globe Color	Glass Cat. #	Plastic Cat. #*
Clear	G24	G63
Green	G25	G65
Blue	G26	
Red	G27	G67
Amber	G28	

Guards



Guard	Guard Cat. #
For use with glass globes only	P21

Junction Boxes and Bracket Bodies



VXF - 4 Hubs, 3 Plugs

VXF - 4 Hubs, 3 Plugs Hub Size (In.)	Cat. #
1/2	VXF10
3/4	VXF20

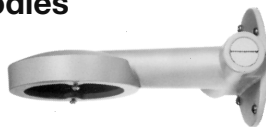

VXT - 3 Hubs, 2 Plugs

VXT - 3 Hubs, 2 Plugs Hub Size (In.)	Cat. #
1/2	VXT10
3/4	VXT20

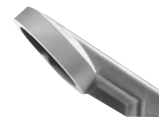

VXA - Stanchion Mount (Non-hazardous Locations)

VXA - Stanchion Mount (Non-hazardous Locations) Hub Size (In.)	Cat. #
1 1/4	VXA4



VXFT - 5 Hubs, 4 Plugs

VXFT - 5 Hubs, 4 Plugs Hub Size (In.)	Cat. #
1/2	VXFT10
3/4	VXFT20



VXT-K1

Mounting Adapter Kit Description

Allows for the mounting of non-Eaton's Crouse-Hinds outlet boxes to the VXT20 wall mount bracket and VXH ceiling mount bracket

Cat. #
VXT K1

*For non-hazardous locations.
†All mountings except stanchion.

5L

5L CPMVF Champ-Pak™ Compact Fluorescent Luminaires

Cl. I, Div. 2, Groups A, B, C, D
 Restricted Breathing Cl. I,
 Div. 2 & Zone 2 (Suffix S826)
 Certified for IEC Zone 2
 (Suffix S826TB)

Cl. II, Groups E, F, G; Cl. III &
 Simultaneous Presence
 Marine & Wet Locations
 3, 3R, 4, 4X; IP56

Applications:

CPMVF Champ-Pak™ luminaires are used:

- Indoor and outdoor wall mounting or vertical surface mounting where minimal luminaire depth is required in:
 - Manufacturing plants and heavy industrial facilities
 - Industrial process facilities such as refineries, chemical, petrochemical, pharmaceutical and platforms
 - Waste or sewage treatment plants
 - Offshore, dockside and harbor installations
- For security and safety lighting in industrial facilities for lighting of loading docks, tunnels, and stairways
- For marine, wet location, hose down, and corrosive environments

Features and Benefits:

- Unique compact shallow-profile design mounts virtually anywhere
- Side hinged cover with two screw closing for easy installation and maintenance
- Gray Corro-free™ epoxy powder coat two-piece housing provides superior corrosion resistance
- Unique stainless steel wire guard accessory attaches without any additional hardware for easy installation and maintenance
- Glass refractor provides uniform light distribution to eliminate glare
- Silicon gaskets make luminaire suitable for NEMA 4X, marine environments
- High power factor ballasts (+90%) are standard, which allow more luminaires per circuit

Certifications and Compliances:

- NEC and CEC:
 - Class I, Division 2, Groups A, B, C, D
 - Class II, Class III & Simultaneous Presence (Class I, Division 2 and Class II)
 - Class I, Zone 2
- IEC:
 - Zone 2 Ex nR IIC
- UL Standards:
 - 844, 2279 Hazardous (Classified) Locations
 - 1598 Luminaires
 - 1598A Marine Locations
- CSA Standards:
 - C22.2 No. 137
- IEC Standards:
 - 60079-15

Standard Materials:

- Luminaire housing and door frame assembly – copper-free aluminum
- External hardware – stainless steel
- Lens – heat- and impact-resistant refractor style glass
- Gaskets – silicon rubber
- Reflector – aluminum light sheet
- Wire guard – stainless steel

Standard Finishes:

- Aluminum – Corro-free™ epoxy powder coat
- Stainless steel – natural

Energy Savings:

- Less wattage used with compact fluorescent lamps compared to equivalent incandescent lamps providing the same light output



Electrical Rating Ranges:

- Wattages: two 26, 32, or 42 watt lamps
- 120–277V, 50–60Hz
- 347V, 60Hz
- 12, 24, and 125VDC (Consult Eaton's Crouse-Hinds)

Options:

Description	Suffix
Restricted Breathing Construction.....	S826
Class I, Division 2 & Zone 2 Suitability	
Cooler Operating Temperatures (T-Numbers)	
Certified for IEC Zone 2	S826TB
Furnished with:	
Terminal Block	
Crimp Terminals	
Factory Assembled with Lamp.....	FA
Fused - protects ballast and capacitors against abnormal line conditions	S658
(Not for use in Canada)	
(Not for marine use)	

Accessories:

Description	Cat. #
Photocell for Field Installation	
• 120V, 50/60Hz	V2PC20
• 208–240V, 50/60Hz	V2PC22
• 277V, 50/60Hz	V2PC27
Stainless Steel Wire Guard	P55

5L

CPMVF Champ-Pak™ Compact Fluorescent Luminaires

Ordering Information
Temperature Performance Data
Dimensions & Weights

5L

Ordering Information:

Hub Size (In.)	Luminaire Watts	Cat. #
3/4 NPT	52	CPMVF2W052
3/4 NPT	64	CPMVF2W064
3/4 NPT	84	CPMVF2W084

	STANDARD VOLTAGE BALLASTS		OPTIONAL BALLASTS		
	NEC/UL & CEC/CSA (cUL)	CEC/CSA (cUL)	(Consult Eaton's Crouse-Hinds)		
Voltage	120-277V 50-60Hz	347V 60Hz	125V DC	12V DC	24V DC
Suffix	/UNV	/347	/125VDC	/012VDC	/024VDC

CPMVF Temperature Performance Data – Consult Eaton's Crouse-Hinds

Dimensions

In Inches:

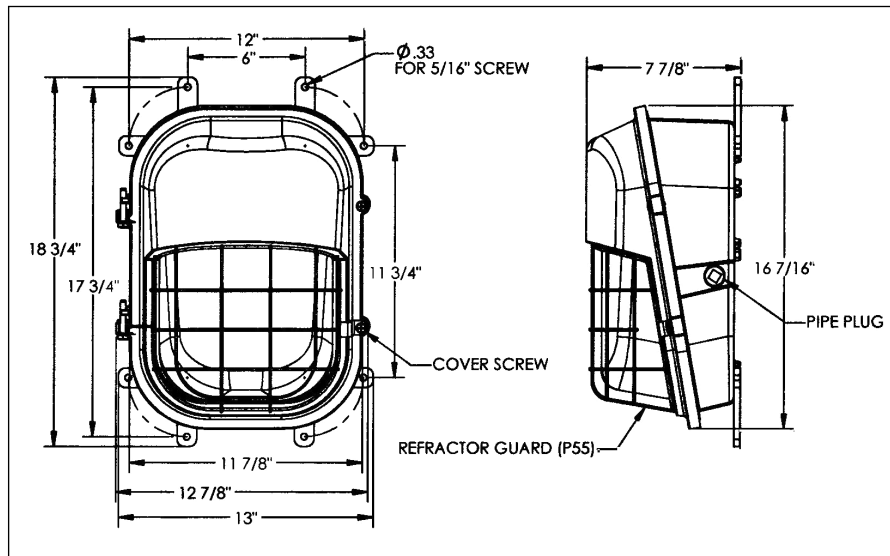

Net Weight:

Description	Lbs.
CPMVF Less Guard	17 lbs.
P55 Guard	0.5 lbs.

5L

5L VMVF Series Fluorescent Luminaires

Champ® Luminaires

Cl. I, Div. 2, Groups A, B, C, D
Cl. I, Zone 2, AEx nR II, Ex nR IIC

IEC Zone 2, Ex nR IIC
UL/CSA
IEC 60079-15

Applications:

VMVF Series Champ Luminaires are used:

- In refineries, chemical, petrochemical, and pharmaceutical plants, wastewater treatment facilities
- In shipboard, drilling rigs, drilling platforms
- In flour and feed mills, grain elevators, sugar and cocoa plants
- In area/structure lighting, security lighting, parking areas

Features and Benefits:

Increased Productivity

- Instant-on luminaire eliminates flicker-free starting and increases safety and productivity

Consistent Design

- Luminaire components are of the same materials as standard VMV and DMV
- Popular components are available from stock; offers visual consistency throughout installation

High Lumen Output

- Compact fluorescent light fixture provides higher lumen output with increased color rendering index (CRI)

Reliable Performance in Any Environment

- Energy-efficient universal ballast suitable for 120-277V 50/60Hz - minimum starting temperature of -18°C provides long lamp life and lamp end-of-life protection
- UL marine rated, NEMA 4X/IP66 luminaire prevents water ingress and is suitable for the most adverse outdoor environments



Certifications and Compliances:

- **NEC/CEC:**
 - Class I, Division 2, Groups A, B, C, D
 - Class I, Zone 2, AEx nR II, Ex nR IIC
- **IEC:**
 - IEC Zone 2, Ex nR IIC
- **UL Standards:**
 - UL844 Hazardous (Classified) Locations
 - UL1598 Luminaires, UL1598A Marine Locations
- **CSA Standards:**
 - C22.2 No. 137
- **IEC Standards:**
 - IEC 60079-15

Ordering Information Example:

		VMV	F	2A	042	GP	/UNV	S714
1. Series	VMV DMV							
2. Lamp/Function	F (Fluorescent) FB (Fluorescent with Battery Back-up) (DMV only)							
3. Mounting Style	Blank J 1 1/2" Stanchion 25° P 1 1/2" Stanchion Straight 2A 3/4" Pendant 3A 1" Pendant 2C 3/4" Ceiling 3C 1" Ceiling 2HA 3/4" Offset Pendant (low wattage only) 2TW 3/4" Wall Mount 3TW 1" Wall Mount 25Q 3/4" Quad Mount							
4. Wattage	042 42W F (VMVF) 084 84W F (DMVF/DMVFB)							
5. Globe and Guard	GP G24 Globe and P21 Guard (VMVF) GP G303 Globe and P33 Guard (DMVF)							
6. Voltage	/UNV 120-277V 50/60Hz Fluorescent /347 (For Canada)							
7. Suffixes	S714 Furnished with Lamps S806 Cover Furnished with Stainless Steel Insert S826 Restricted Breathing (Cl. I, Div. 2 & Zone 2 Suitability, Cooler T-Numbers) S826TB Restricted Breathing Supplied with Terminal Block Connections (Certified for IEC Zone 2) S858 Red Paint for Exterior S890 Quick Clip FA Factory Assembled with Lamps Installed							

Crouse-Hinds
by E.T.N.

DMVF Series Compact Fluorescent Champ® Luminaires

Cl. I, Div. 2, Groups A, B, C, D
 Restricted Breathing Cl. I, Div. 2 & Zone 2 (Suffix S826)
 Certified for IEC Zone 2 (Suffix S826TB)

Cl. II, Groups E, F, G; Cl. III & Simultaneous Presence
 Marine & Wet Locations
 3, 3R, 4, 4X; IP66

5L

Applications:

DMVF Series Champ Luminaires are used:

- In areas made hazardous by abnormal conditions resulting in the presence of flammable vapors or gases
- In areas made hazardous by the presence of combustible dusts
- Where combustible dusts and flammable vapors are present simultaneously
- In marine applications where water spray and corrosive atmospheres are considerations
- On installations where vibration and rough usage are problematic
- Where a cool, efficient light source is required
- In areas that require lamps to reach full illumination immediately
- In refineries, chemical and petrochemical facilities, grain processing, handling or storage facilities, manufacturing plants, wastewater treatment plants, sewage treatment plants, oil terminals, food processing facilities, breweries, and any other manufacturing or processing facility where safe, reliable, hazardous area fluorescent or auxiliary lighting is needed

Standard Features:

- Housings made of die-cast copper-free aluminum (less than 0.4 of 1% copper) for strength and resistance to corrosion
- Mounting modules equipped with integral hub set screws for vibration resistance (ceiling, pendant, and quad mounts)
- Hubs are provided with an integral conduit stop and bushing to help prevent damage to field wiring during installation
- Epoxy powder finish and stainless steel external hardware for resistance to corrosion
- Long-life gaskets which provide seals between mounting module, housing, and optical assembly
- Grounding wire for safety
- Cool operating design
- Optional stainless steel open bottom guard permits direct access to the globe for easy relamping
- Optional battery pack ballast for auxiliary lighting

Certifications and Compliances:

- NEC and CEC:
 - Class I, Division 2, Groups A, B, C, D
 - Class II, Class III & Simultaneous Presence (Class I, Division 2 and Class II)
 - Class I, Zone 2
- IEC:
 - Zone 2 Ex nR IIC
- UL Standards:
 - 844 Hazardous (Classified) Locations
 - 1598 Luminaires
 - 1598A Marine Locations
- CSA Standards:
 - C22.2 No. 137
- IEC Standards:
 - 60079-15

Standard Materials:

- Ballast housings and mountings – copper-free aluminum (less than 0.4 of 1%)
- Exterior hardware and guards – stainless steel
- Reflectors – Krydon® fiberglass-reinforced polyester
- Globe – heat- and impact-resistant internally fluted glass

Standard Finishes:

- Aluminum – gray epoxy powder coat
- Krydon material – high reflectance white
- Stainless steel – natural

Options:

Description	Suffix
Restricted Breathing Construction	S826
Class I, Division 2 & Zone 2 Suitability	
Cooler Operating Temperatures (T-Numbers)	
Certified for IEC Zone 2 (Suffix S826TB)	S826TB
Furnished with	
Terminal Block	
Crimp Terminals	
Factory assembled with lamps installed for additional labor savings	FA
Fused – to protect ballast against abnormal line conditions (not available on CSA certified fixtures) (not suitable for marine applications)	S658
Lamps supplied with fixture.....	S714
Top hat with stainless steel threaded insert to attach ballast housing.....	S806
TEFLON® coating on globe for increased shatter protection.....	S808
Quick-Clip	S890



Accessories:

Reflectors (to be used with globe)

Type	Cat. #
Dome	RD739
30° Angle	RA739

To be ordered separately.

Energy Savings

- Less wattage used with compact fluorescent lamps compared to equivalent incandescent lamps providing the same light output

Electrical Rating Ranges:

- Wattage: Two 26, 32, or 42 watt lamps
- 120–277V, 50–60Hz
- 347V, 60Hz
- 12, 24, and 125VDC









5L

DMVF Series Compact Fluorescent

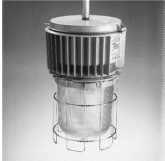
Champ® Luminaires

Cl. I, Div. 2, Groups A, B, C, D
 Restricted Breathing Cl. I, Div. 2
 & Zone 2 (Suffix S826)
 Certified for IEC Zone 2
 (Suffix S826TB)

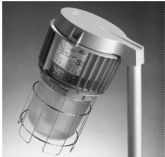
Cl. II, Groups E, F, G; Cl. III &
 Simultaneous Presence
 Marine & Wet Locations
 3, 3R, 4, 4X; IP66

	Mounting Style	Hub Size (In.)	Luminaire Watts	DMVF Series Fluorescent with G303 Globe and P33 Guard Cat. #
	Pendant Mount	3/4	52	DMVF2A052GP
		1		DMVF3A052GP
		3/4	64	DMVF2A064GP
		1		DMVF3A064GP
		3/4	84	DMVF2A084GP
		1		DMVF3A084GP
	Flexible Pendant Mount	3/4	52	DMVF2HA052GP
		3/4	64	DMVF2HA064GP
		3/4	84	DMVF2HA084GP
	Ceiling Mount Thru-Feed	3/4	52	DMVF2C052GP
		1		DMVF3C052GP
		3/4	64	DMVF2C064GP
		1		DMVF3C064GP
		3/4	84	DMVF2C084GP
		1		DMVF3C084GP
	Wall Mount Thru-Feed	3/4	52	DMVF2TW052GP
		1		DMVF3TW052GP
		3/4	64	DMVF2TW064GP
		1		DMVF3TW064GP
		3/4	84	DMVF2TW084GP
		1		DMVF3TW084GP
	Quad-Mount	3/4	52	DMVF25Q052GP
		3/4	64	DMVF25Q064GP
		3/4	84	DMVF25Q084GP
	Stanchion Mount	1 1/2	52	DMVFJ052GP
		1 1/2	64	DMVFJ064GP
		1 1/2	84	DMVFJ084GP
	Stanchion Mount	1 1/2	52	DMVFP052GP
		1 1/2	64	DMVFP064GP
		1 1/2	84	DMVFP084GP

5L

1. Catalog numbers are basic numbers. Voltages must be specified.

Voltage Suffix	STANDARD VOLTAGE BALLASTS		OPTIONAL BALLASTS		
	NEC/UL & CEC/CSA (cUL)	CEC/CSA (cUL)	125V DC /125VDC	12V DC /012VDC	24V DC /024VDC
	120-277V 50-60Hz /UNV	347V 60Hz /347			

DMVF luminaires are available in components.

A complete luminaire consists of:

- I. Champ Cover (Mounting Module)
- II. DMVF Ballast Housing
- III. Globe, Globe Guard, Globe Reflectors

I. Champ Cover (Mounting Module):

Type	Conduit	Cat. #
Pendant Mount	3/4"	APM2
	1	APM3
Flexible Pendant	3/4"	HPM2
Ceiling	3/4"	CM2
	1	CM3
Wall	3/4"	TWM2
	1	TWM3
Stanchion - 25 Degree Angle	1 1/2"	JM5
Stanchion - Straight	1 1/2"	PM5
Quad-Mount	3/4"	QM25

II. Ballast Housings:

Complete catalog number must have the **voltage suffix** (UNV shown) and any **options suffixes**.

Lamp Type	Lamp Watts	Cat. #
Compact Fluorescent	2 (26W)	DMVF052/UNV
	2 (32W)	DMVF064/UNV
	2 (42W)	DMVF084/UNV

III. Globe, Guards and Reflectors:

Type	Cat. #
Globe	G303
Teflon Coated	G303S808
Globe Guard	P33
Globe Reflector-Dome	RD739
Globe Reflector-Angle	RA739



Champ® Luminaires

COVERS:

PENDANT

- APM2 3/4 IN.
- APM3 1 IN.
- HPM2 3/4 IN.

WALL

- TWM2 3/4 IN.
- TWM3 1 IN.

QUAD—MOUNT

- QM25 3/4 IN.

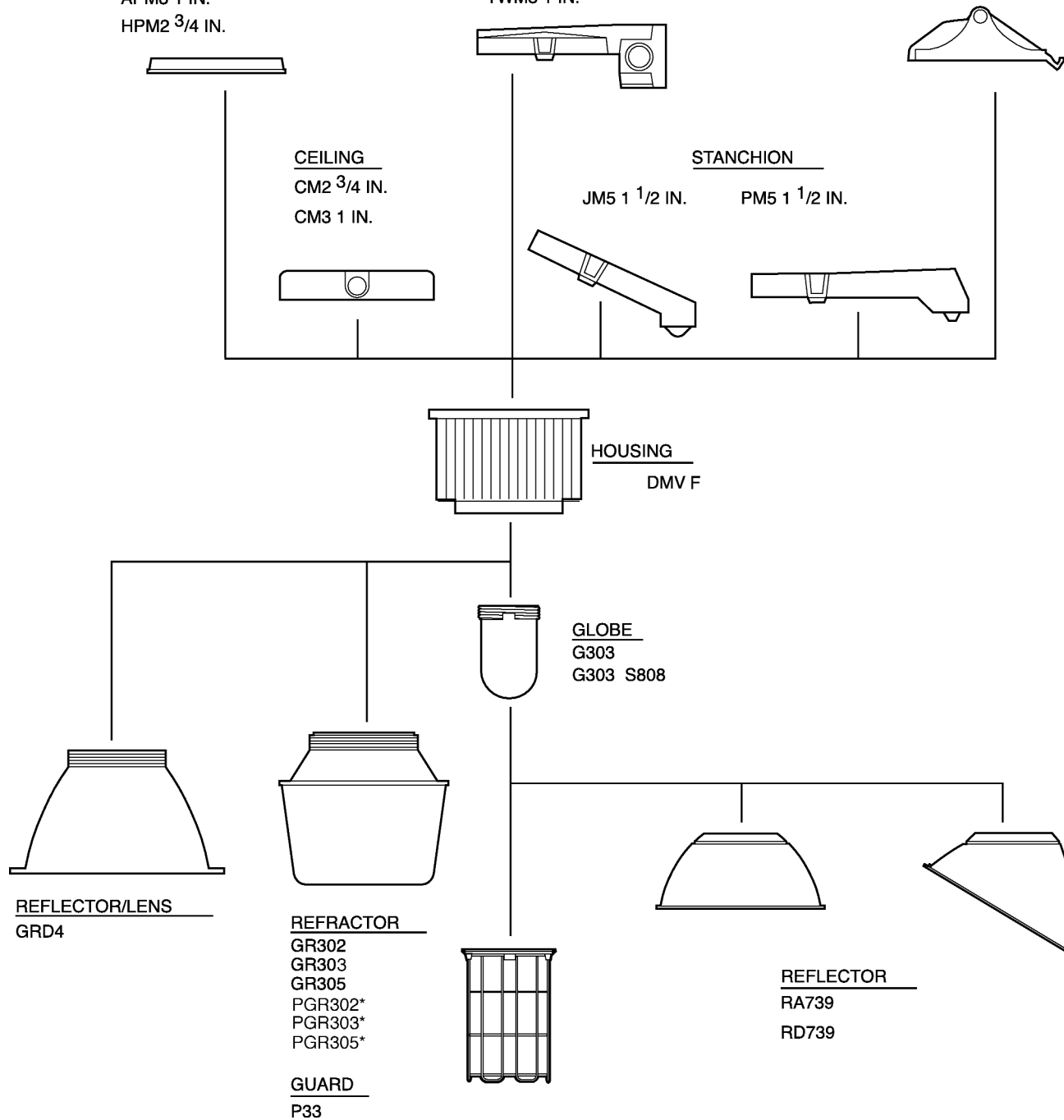

5L

*These plastic reflectors are for non-hazardous areas only (50-100W max).

DMVF Series Compact Fluorescent

Temperature Performance Data
Weights

5L

Champ® Luminaires

Temperature Performance Data:

Lamp Watts	Minimum Operating Temperature	Maximum Ambient Temp.	Class I		Class II	Simultaneous Presence		Supply Wire °C
			Non-restricted Breathing	Restricted Breathing		Non-restricted Breathing	Restricted Breathing	
Fluorescent:	DMVF		Div. 2	Zone 2 or Div. 2	Division 1	Cl. I, Div. 2/Cl. II	Cl. I, Zone 2 or Div. 2/Cl. II	
52 Watt	-20°C (4°F)	40°C (104°F)	T3	T6	T6	T3/T6	T6	60
64 Watt	-20°C (4°F)	40°C (104°F)	T3	T6	T6	T3/T6	T6	60
84 Watt	-20°C (4°F)	40°C (104°F)	T3	T6	T6	T3/T6	T6	60

Net Luminaire Weights:

Luminaire Series	Lamp Watts	Luminaire with Globe, Guard (lbs.)
DMVF	52, 64, 84	18 ³ / ₄
Type		Lbs.

Add for mounting modules:

Pendant	1 ¹ / ₄
Flexible Pendant	1 ¹ / ₂
Ceiling	2 ³ / ₄
Wall	4 ¹ / ₂
Quad-Mount	3 ¹ / ₂
Angle Stanchion	3 ¹ / ₂
Straight Stanchion	4 ¹ / ₂

Add for reflectors:

Dome	1 ¹ / ₄	30° Angle	1 ³ / ₄
------	-------------------------------	-----------	-------------------------------

Deduct: 1 lb. for luminaire with P33 Guard

5L

DMVF Series Compact Fluorescent

Champ® Luminaires

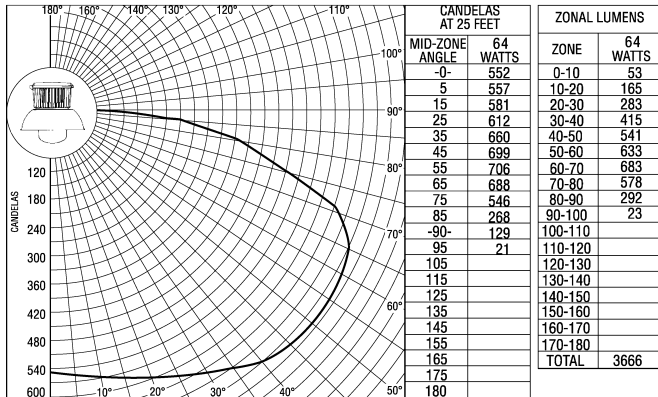

Note: For 52 watt DMVF applications, use a .75 multiplier.
For complete 84W IES files, please log onto www.crouse-hinds.com and go to Resources > Specification and Design Support > Photometric Files.

DMVF Photometric Data

Isofootcandle Chart:
Luminaire with globe and dome reflector
DMVF064GRD Dome Reflector

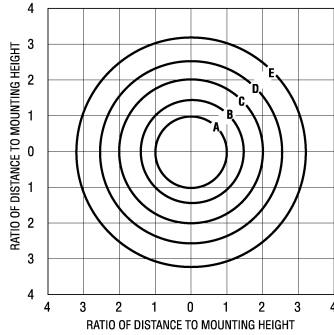

Footcandle Values for Isofootcandle Lines

Mtg. Hgt.	A	B	C	D	E
8'	4.00	2.00	1.00	0.50	0.25
10'	2.56	1.28	0.64	0.32	0.16
12'	1.78	0.89	0.44	0.22	0.11
16'	1.00	0.50	0.25	0.13	0.06

DMVF064GRD Dome Reflector

Coefficient of Utilization

Effective Floor Cavity Reflectance 20%

Eff. Ceil.	Room Cavity Ratio	Room Cavity Ratio									
		Wall	1	2	3	4	5	6	7	8	9
80*	50*	.741	.617	.524	.452	.396	.351	.314	.283	.258	.236
	30*	.694	.548	.445	.370	.314	.271	.237	.210	.188	.169
	10*	.652	.491	.382	.308	.254	.214	.183	.159	.140	.125
70*	50*	.722	.601	.510	.440	.386	.342	.307	.277	.252	.231
	30*	.679	.537	.437	.364	.309	.267	.234	.207	.185	.167
	10*	.640	.483	.378	.305	.252	.212	.182	.158	.139	.124
50*	50*	.686	.570	.484	.418	.367	.326	.293	.265	.242	.223
	30*	.650	.516	.421	.351	.299	.259	.227	.202	.181	.163
	10*	.617	.470	.369	.299	.247	.209	.180	.155	.138	.123
30*	50*	.653	.542	.460	.398	.350	.311	.280	.254	.233	.214
	30*	.623	.497	.406	.340	.290	.251	.221	.197	.176	.160
	10*	.596	.457	.361	.293	.243	.206	.177	.154	.136	.121
10*	.50*	.622	.516	.437	.379	.333	.297	.268	.244	.224	.206
	30*	.598	.478	.392	.329	.271	.244	.215	.192	.172	.156
	10*	.576	.444	.352	.287	.239	.203	.175	.152	.135	.120
0*	0*	.557	.424	.332	.267	.220	.184	.157	.136	.119	.105

*Percent Reflectance.

DMVF Series Compact Fluorescent

Dimensions

5L

Champ® Luminaires

Dimensions In Inches:

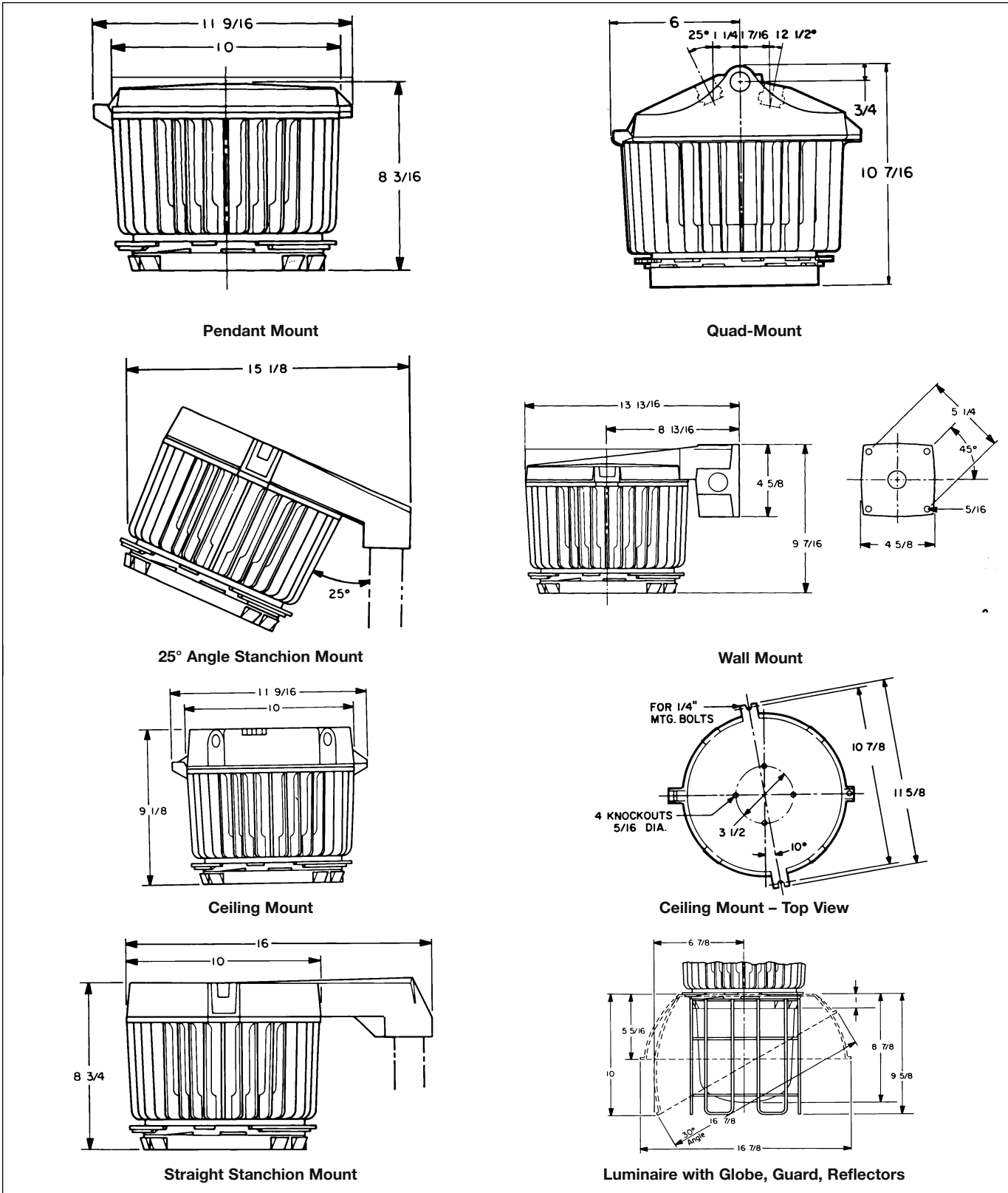

5L

N2MVF Series Compact Fluorescent

Champ® Non-metallic Luminaires

Cl. I, Div. 2, Groups A, B, C, D
Cl. II, Groups F, G
Cl. III & Simultaneous Presence

Marine & Wet Locations
3, 3R, 4, 4X; IP56

Applications:

N2MVF Series Champ Luminaires are used:

- In areas in which ignitable concentrations of flammable gases or vapors will be present due to abnormal, unusual or accidental conditions
- In installations where moisture, dirt, vibration, corrosion, or rough usage are concerns
- Wherever the damaging effects of water, wind, snow, sleet, hot sun, or any combination of these elements are found
- Ideal for marine use; resists the harmful effects of salt water
- Withstands the harshest of corrosive environments
- To provide low wattage spot and floodlighting
- For general area lighting
- In manufacturing plants, refineries, chemical, petrochemical and other industrial process facilities, wastewater and sewage treatment facilities, offshore, dockside, and harbor installations as well as other heavy industrial applications

Features and Benefits:

- Housings and mounting modules made of polyphenylene sulfide (PPS) for strength and maximum resistance to corrosion
- Pendant mounting module equipped with integral hub set screws for vibration resistance
- Hubs are provided with an integral bushing to help prevent damage to field wiring during installation and ground connection for positive bonding
- Guard, hub inserts, stanchion elbow, and hardware made of stainless steel for maximum resistance to corrosion
- Grounding wire for safety
- Stainless steel open bottom guard permits direct access to the globe for easy relamping
- Hinged assembly allows the luminaire to hang free during installation to permit the use of both hands when wiring
- One external captive screw for ease of installation
- Handle – hinge assembly doubles as a handle for ease of installation, especially when carrying up a ladder

Additional Features:

Fluorescent Energy Savings

- Less wattage used with compact fluorescent lamps compared to equivalent incandescent lamps providing the same light output

Certifications and Compliances:

- NEC and CEC:
 - Class I, Division 2, Groups A, B, C, D
 - Class II, Class III & Simultaneous Presence (Class I, Division 2 and II)
- UL Standards:
 - 844 Hazardous (Classified) Locations
 - 1598 Luminaires
 - 1598A Marine Locations
- CSA Standards:
 - C22.2 No. 137

Standard Materials:

- Housing, mounting modules – polyphenylene sulfide (PPS)
- Guard, hub inserts, stanchion elbow, hardware – stainless steel
- Globe – heat- and impact-resistant, internally fluted glass
- Gaskets – silicone rubber

Electrical Ratings:

- Wattages: Two 26 or 32 watt lamps
- 120-277V, 50-60Hz
- 347V, 60Hz
- 12, 24, and 125 VDC



Options:

Description	Suffix
Wall-Mount Arm For converting a ceiling-mount luminaire to a wall mount	N2MV-WM1
Factory Assembled For a factory assembled luminaire with lamps installed	FA
Fusing To protect ballast against abnormal line conditions (not suitable for marine applications)	S658
Furnished with Lamps	S714
Teflon Coated Globe Provides additional protection against shattered glass fragments when subject to thermal shock, etc.	S808

Average Luminaire Weight

Description	Lbs.
Body, mounting module, globe, guard, and reflector	30

Ordering Information:

Mounting Style	Hub Size in.	Lamp Watts	With G303 Globe and P33 Guard Cat. #
Pendant Mount	3/4	52	N2MVF2A052GP
	1		N2MVF3A052GP
	3/4	64	N2MVF2A064GP
	1		N2MVF3A064GP
Ceiling Mount Thru-Feed	3/4	52	N2MVF2C052GP
	1		N2MVF3C052GP
	3/4	64	N2MVF2C064GP
	1		N2MVF3C064GP
Stanchion Mount 25° Angle	1 1/2	52	N2MVFJ052GP
	1 1/2	64	N2MVFJ064GP

Voltage Suffix	Standard Voltage Ballasts		Optional Ballasts		
	NEC/UL & CEC/CSA (cUL)	CEC/CSA (cUL)	125V DC /125VDC	12V DC /012VDC	24V DC /024VDC
	120-277V 50-60Hz /UNV	347V 60Hz /347			

Temperature Performance Data:

Lamp Watts	Minimum Operating Temperature	Maximum Ambient Temp.	Class I		Supply Wire °C
			Non-restricted Breathing	Class II	
Fluorescent:	N2MVF		Division 2	Division 1	
52 & 64 Watt	-18°C (0°F)	40°C (104°F)	T2D	T4	85

Crouse-Hinds
by **E.T.N**

N2MVF Series - Ordering by Components

5L

N2MVF Luminaires are available in components.

A complete luminaire consists of:

- I. N2MV Cover (Mounting Module)
- II. N2MV Ballast Housing
- III. Globe, Refractors, Guards, Reflectors

I. N2MV Cover (Mounting Module):

Type	Conduit	Cat. #
Pendant	3/4"	N2APM2
	1"	N2APM3
Ceiling	3/4"	N2CM2
	1"	N2CM3
Wall (Use wall bracket accessory with Ceiling Cover)	3/4"	N2MV WM1 and N2CM2
	1"	N2MV WM1 and N2CM3
Stanchion – 25 Degree Angle	1 1/2"	N2JM5

II. Ballast Housings:

Complete catalog number must have the **voltage suffix** (UNV shown) and any **options suffixes**.

Lamp Type	Lamp Watts	Cat. #
Compact Fluorescent	2 (26W)	N2MVF052/UNV
	2 (32W)	N2MVF064/UNV

III. Globe, Guards, and Reflectors:

Type	Cat. #
Globe	G303
Globe Teflon Coated	G303S808
Globe Guard	P33
Reflector Dome	RD739
Reflector Angle	RA739

5L

N2MVF Series Compact Fluorescent

Champ® Non-metallic Luminaires

A complete luminaire consists of a cover mount, a ballast housing and a globe, with or without guard, refractor or reflector.

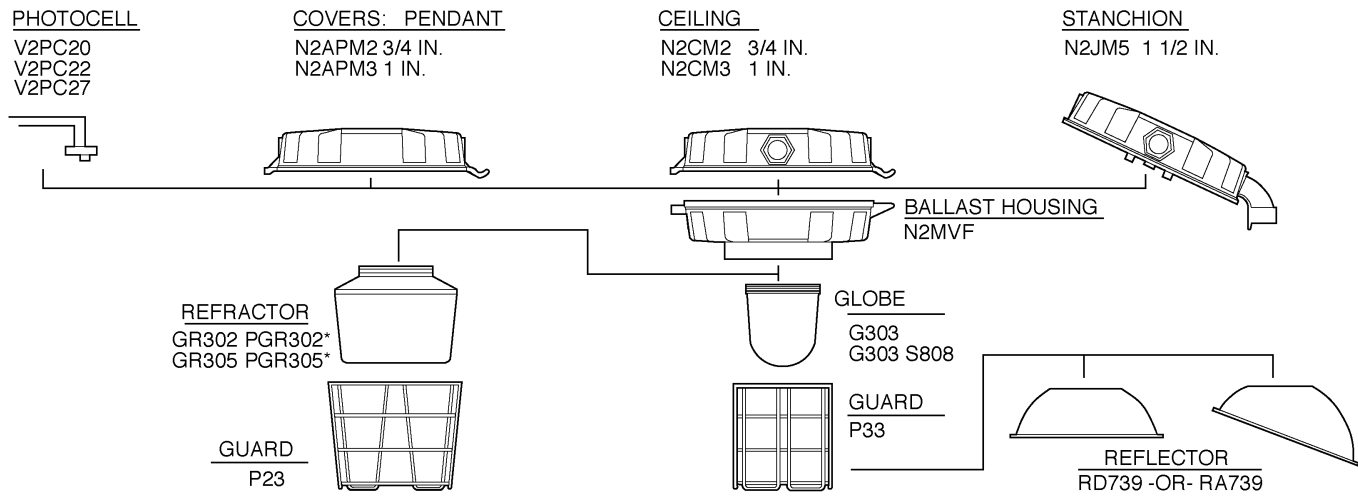

All Components are suitable for use in ordinary locations, Class I, Div. 2 and wet locations.

N2MVF Series Compact Fluorescent

Champ® Non-metallic Luminaires

Dimensions
Weights

5L

Dimensions In Inches:

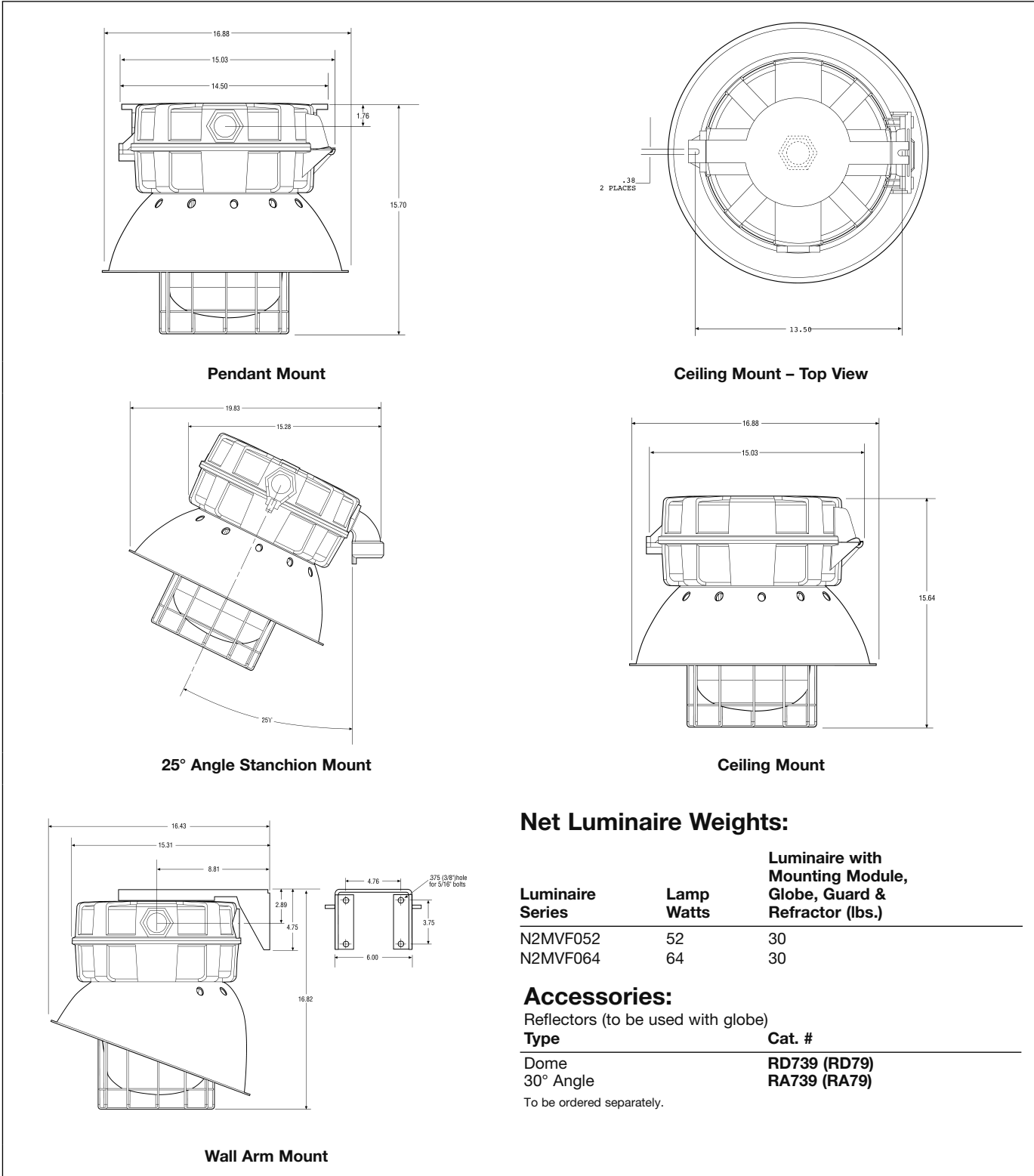

Net Luminaire Weights:

Luminaire Series	Lamp Watts	Luminaire with Mounting Module, Globe, Guard & Refractor (lbs.)
N2MVF052	52	30
N2MVF064	64	30

Accessories:

Reflectors (to be used with globe)

Type	Cat. #
Dome	RD739 (RD79)
30° Angle	RA739 (RA79)

To be ordered separately.

5L

N2MVF Series Compact Fluorescent

Champ® Non-metallic Luminaires

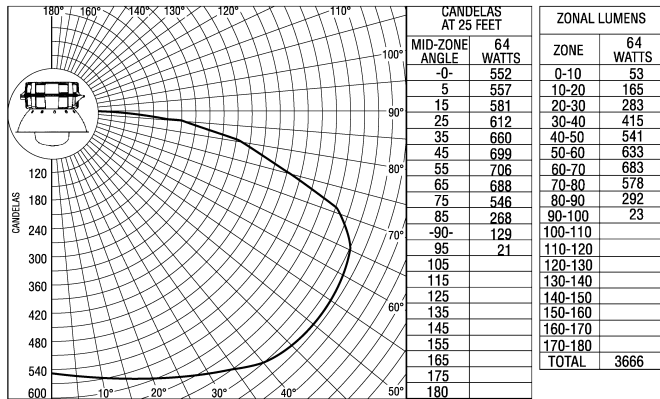

Note: For 52 watt N2MVF applications, use a .75 multiplier.

N2MVF Photometric Data

Isofootcandle Chart:
Luminaire with globe and dome reflector

N2MVF064GRD Dome Reflector

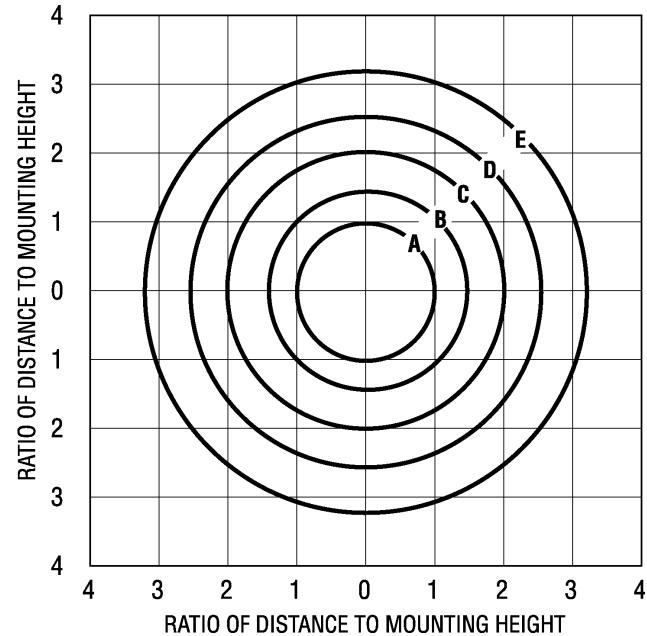

Footcandle Values for Isofootcandle Lines

Mounting Height	A	B	C	D	E
8'	4.00	2.00	1.00	0.50	0.25
10'	2.56	1.28	0.64	0.32	0.16
12'	1.78	0.89	0.44	0.22	0.11
16'	1.00	0.50	0.25	0.13	0.06

N2MVF064GRD Dome Reflector Coefficients of Utilization

Effective Floor Cavity Reflectance 20%

Eff. Ceil.	Wall	Room Cavity Ratio									
		1	2	3	4	5	6	7	8	9	10
80*	50*	.741	.617	.524	.452	.396	.351	.314	.283	.258	.236
	30*	.694	.548	.445	.370	.314	.271	.237	.210	.188	.169
	10*	.652	.491	.382	.308	.254	.214	.183	.159	.140	.125
70*	50*	.722	.601	.510	.440	.386	.342	.307	.277	.252	.231
	30*	.679	.537	.437	.364	.309	.267	.234	.207	.185	.167
	10*	.640	.483	.378	.305	.252	.212	.182	.158	.139	.124
50*	50*	.686	.570	.484	.418	.367	.326	.293	.265	.242	.223
	30*	.650	.516	.421	.351	.299	.259	.227	.202	.181	.163
	10*	.617	.470	.369	.299	.247	.209	.180	.155	.138	.123
30*	50*	.653	.542	.460	.398	.350	.311	.280	.254	.233	.214
	30*	.623	.497	.406	.340	.290	.251	.221	.197	.176	.160
	10*	.596	.457	.361	.293	.243	.206	.177	.154	.136	.121
10*	50*	.622	.516	.437	.379	.333	.297	.268	.244	.224	.206
	30*	.598	.478	.392	.329	.271	.244	.215	.192	.172	.156
	10*	.576	.444	.352	.287	.239	.203	.175	.152	.135	.120
0*	0*	.557	.424	.332	.267	.220	.184	.157	.136	.119	.105

*Percent Reflectance.

EVLPF Series Compact Fluorescent

Low Profile Hazard•Gard® Luminaires

Cl. I, Div. 1, Groups B
(GB Suffix), C, D
Cl. I, Zone 1, Groups IIB + H2
(GB Suffix), IIB, IIA
Cl. II, Div. 1, Groups E, F, G
Class III, Simultaneous Presence

Marine & Wet
Locations
3, 3R, 4, 4X; IP66

5L

Applications:

Eaton's Crouse-Hinds Low Profile Hazard•Gard® luminaires are used in:

- Areas where flammable or explosive vapors or gases are present
- Hazardous areas, both indoors and outdoors, where long life and low maintenance costs are desired
- Petroleum refineries, chemical, petrochemical and pharmaceutical plants, oil terminals, gas plants and other heavy process industry facilities
- Waste treatment facilities
- Drilling platforms and other coastal and offshore hazardous areas

Features and Benefits:

- Small, compact size
- Two start Acme threaded construction
- Lightweight copper-free aluminum housing with powdered epoxy finish
- All exterior hardware is corrosion-resistant stainless steel
- Four mounting arrangements - pendant, ceiling, wall bracket, and stanchion
- Wide range of light sources and wattages
- Marine and NEMA 4X construction
- Integral ballast
- High power factor (90%+) ballasts
- Uses same mounting modules as the standard Hazard•Gard®
- Internally fluted glass globes
- Krydon® construction dome and angle reflectors – won't rust, corrode, dent, chip, or peel
- Now available in components – luminaire body, mounting module, guard, reflectors
- Three wire construction is standard on fluorescent emergency lighting
- Perfect where low mounting restrictions are a concern
- Easier assembly, installation and maintenance
- Superior corrosion resistance
- Suit any lighting layout
- Meet specific lighting needs
- Outdoor, hose down, marine, and corrosive environments suitable
- Lowest installed cost
- Allows more luminaires per circuit
- Easy retrofitting when the EVLPF is the preferred choice
- Reduces glare and distributes light evenly – ideal for adverse environments typical of industrial facilities
- Easily stocked for quick ship requirements
- For energy conservation, luminaires can be switched off without affecting the emergency operation feature



Certifications and Compliances:

- NEC and CEC:
 - Class I, Division 1, Groups B (GB suffix), C, D
 - Class I, Zone 1, Groups IIB + H2 (GB Suffix), IIB, IIA
 - Class II, Class III & Simultaneous Presence (Class I and Class II)
- UL Standards:
 - 844 Hazardous (Classified) Locations
 - 1598 Luminaires
 - 1598A Marine Locations
- CSA Standards
 - C22.2 No. 137

Standard Materials:

- Mounting modules, cover, ballast housing, globe holder – copper-free aluminum
- Globe – heat- and impact-resistant glass
- Exterior hardware – stainless steel
- Reflectors (dome & angle) – Krydon® fiberglass-reinforced polyester

Options:

Description	Suffix
Group B suitability	GB
Fused (not suitable for marine applications)	S658
Factory assembled with lamps	FA

Accessories:

Description	Cat. #
Dome reflector	RD739
Angle reflector	RA739

Standard Finishes:

- Copper-free aluminum – Corro-free™ powdered epoxy
- Krydon – white
- Stainless steel guard

Ratings (Electrical/Size):

Sources/Wattage:

- 52W (two 26W lamps) & 64W (two 32W lamps)
 - 120–277V, 50–60Hz
 - 347V, 60Hz
 - 12, 24, 125 VDC
- Conduit Entries:
- ¾", 1" NPT – Pendant, Wall Bracket, Ceiling
 - 1¼" NPT – Stanchion



5L EVLPF Series Compact Fluorescent

Low Profile Hazard•Gard® Luminaires

Cl. I, Div. 1, Groups B (GB Suffix), C, D
 Cl. I, Zone 1, Groups IIB + H₂ (GB Suffix), IIB, IIA
 Cl. II, Div. 1, Groups E, F, G
 Class III, Simultaneous Presence

Marine & Wet Locations
 3, 3R, 4, 4X; IP66

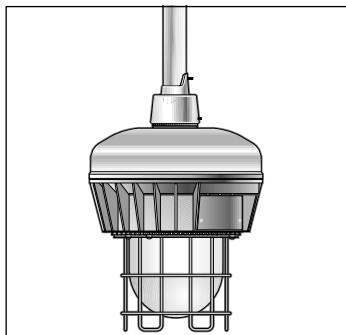

Pendant Mount

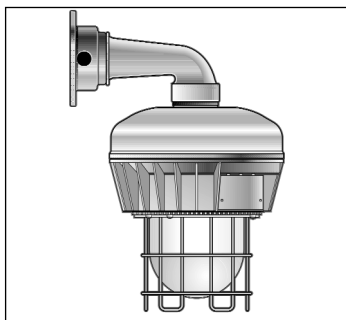

*Wall Bracket Mount

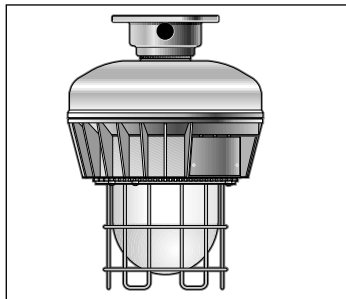

*Ceiling Mount

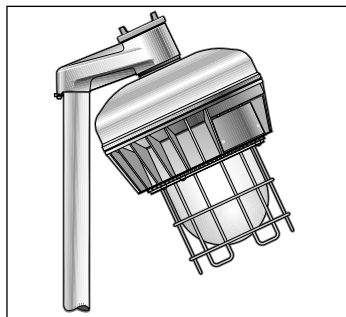

Stanchion Mount

Watt	Hub Size (In.)	Pendant	Wall Bracket*	Ceiling*	Stanchion	Luminaire Body Less Mounting Module & Guard
		With Guard Cat. #	With Guard Cat. #	With Guard Cat. #	With Guard Cat. #	Cat. #
Fluorescent – High Power Factor Ballast (Min. P.F. 90%)						
52W	3/4	EVLPPFA02521	EVLPPFBX02521	EVLPPFCX02521		EVLPPF0520
	1	EVLPPFA03521	EVLPPFBX03521	EVLPPFCX03521		
	1 1/4				EVLPPFJ04521	
64W	3/4	EVLPPFA02641	EVLPPFBX02641	EVLPPFCX02641		EVLPPF0640
	1	EVLPPFA03641	EVLPPFBX03641	EVLPPFCX03641		
	1 1/4				EVLPPFJ04641	

Watt	Hub Size (In.)	Pendant	Wall Bracket*	Ceiling*	Stanchion
		Without Guard Cat. #	Without Guard Cat. #	Without Guard Cat. #	Without Guard Cat. #
Fluorescent – High Power Factor Ballast (Min. P.F. 90%)					
52W	3/4	EVLPPFA02520	EVLPPFBX02520	EVLPPFCX02520	
	1	EVLPPFA03520	EVLPPFBX03520	EVLPPFCX03520	
	1 1/4				EVLPPFJ04520
64W	3/4	EVLPPFA02640	EVLPPFBX02640	EVLPPFCX02640	
	1	EVLPPFA03640	EVLPPFBX03640	EVLPPFCX03640	
	1 1/4				EVLPPFJ04640

Complete Catalog Number as follows:

1. Voltages - Add suffix as follows:

Voltage Suffix	Standard Voltage Ballasts - 60Hz		Optional Ballasts		
	NEC/UL & CEC/CSA (cUL) /UNV	CEC/CSA (cUL) /347	125V DC /125VDC	12V DC /012VDC	24V DC /024VDC

5L

*Ceiling and bracket mounts have 4 hubs: 3 are plugged.

EVLPF Series Ordering By Components

5L

EVL P Luminaires are available in components.

A complete light fixture consists of:

- I. Mounting Module
- II. Fixture Body
- III. Guard, Dome Reflector, Angle Reflector, or Exit Sign

Mounting Modules:

Type	Conduit	Cat. #
Pendant	3/4"	EVMP2
	1	EVMP3
Ceiling & Wall Box	3/4"	EV22
	1	EV33
Wall Bracket Arm	Use EV22 or EV33 box with EV87	EV87
Stanchion	1 1/4"	EVMJ4

Guards

Fluorescent

EV512

Reflectors

Dome
Angle

RD739
RA739

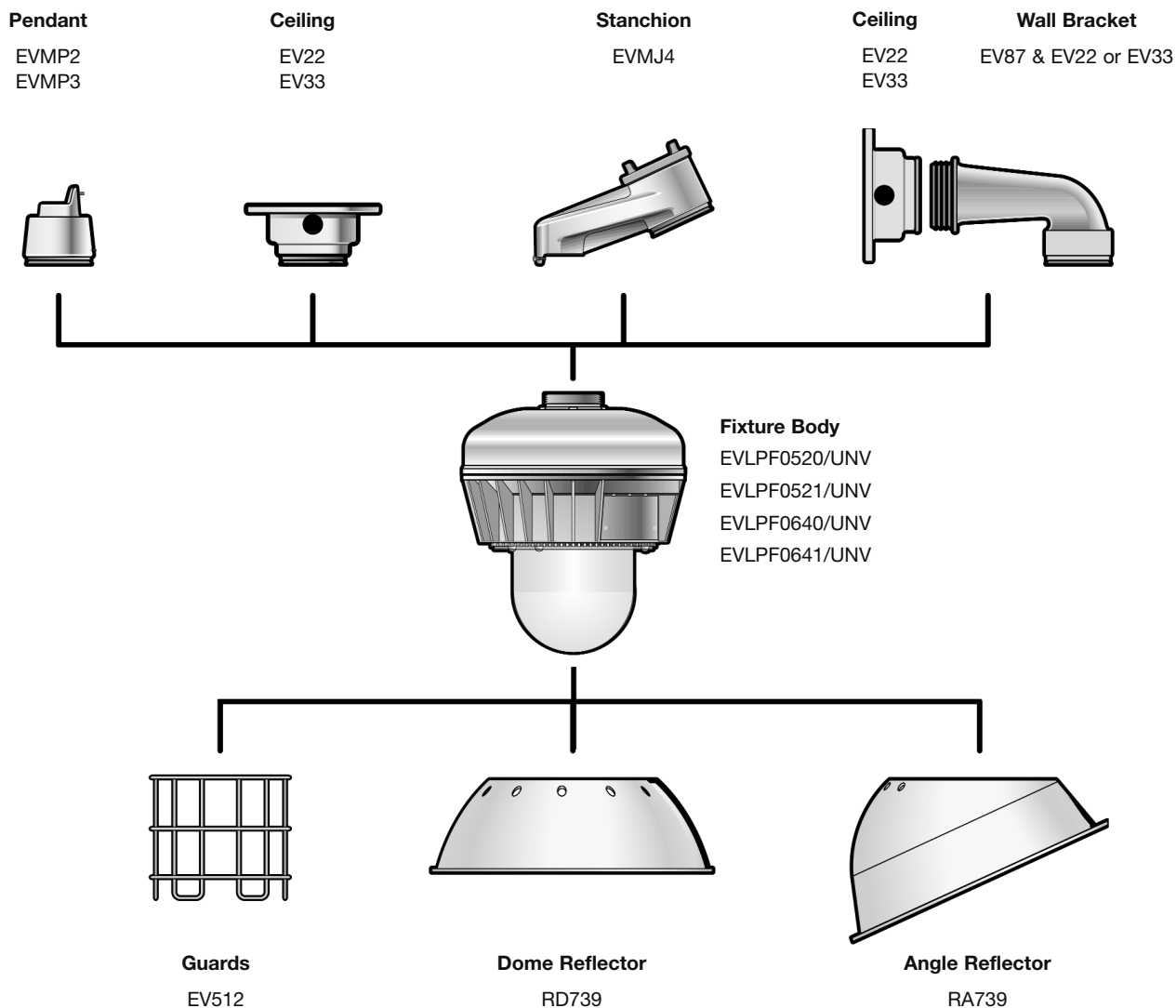

5L

5L EVLPF Series Compact Fluorescent

Dimensions and Weights

Low Profile Hazard•Gard®
Luminaires

Temperature Performance Data:

Fluorescent Fixtures Maximum Ambient		Class I, Group B (w/GB suffix) Groups C, D Class I, Zone I 40°C	Class II, Groups E, F, G Class III Simultaneous Presence 40°C	Supply Wire °C	Minimum Operating Temperature
Fluorescent	52W & 64W	T6	T6	75°C	-18°C

Dimensions In Inches:

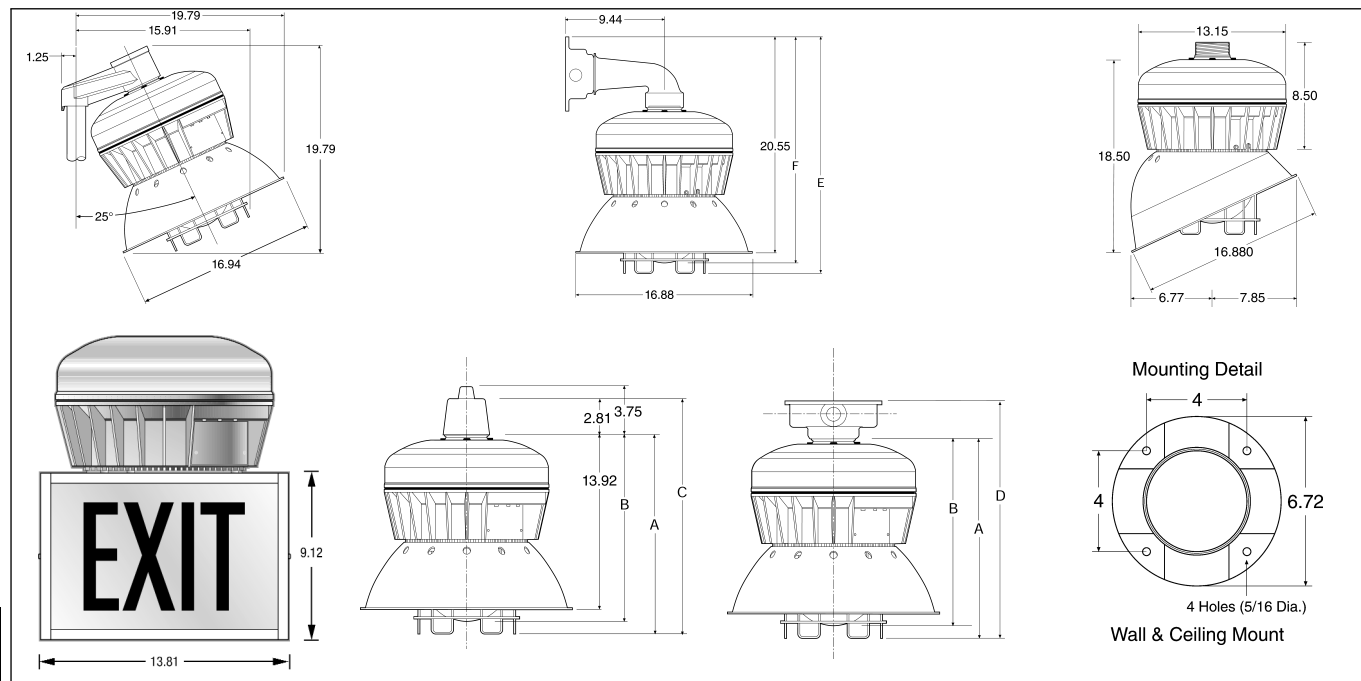

	A	B	C	D	E	F
Fluorescent	15.69	14.69	18.25	18.46	22.34	21.30

Weights:

Item	Lbs.
Fluorescent (EVLPF)	31.5
Add Mounting Modules:	
Pendant	1
Ceiling	2
Bracket	4.5
Stanchion	2.5
Add For Reflectors & Exit Sign:	
RA739	1
RD739	1
DMVF-EXD	5
Deduct .5 lb for Wire Guard	

5L

EVLPF Series Compact Fluorescent

Photometric Data

5L

Low Profile Hazard•Gard® Luminaires

Luminaire with Globe and Guard EVLPPA03641 Two 32 W Compact Fluorescent

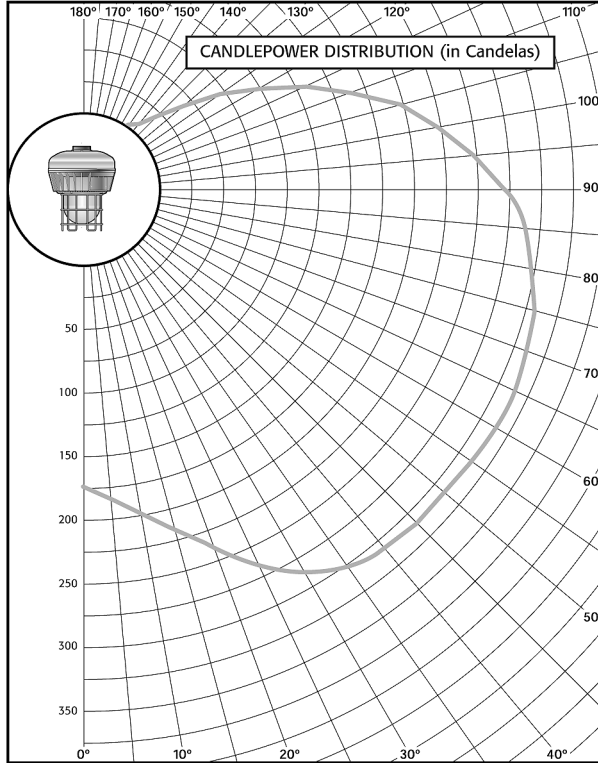

CANDELAS		ZONAL LUMENS	
Mid-Zone Angle	Candelas	Zone	Lumens
0	174	0-10	18
5	187	10-20	61
15	219	20-30	115
25	263	30-40	174
35	299	40-50	233
45	313	50-60	294
55	315	60-70	345
65	317	70-80	368
75	309	80-90	365
85	284	90-100	321
95	248	100-110	234
105	198	110-120	134
115	135	120-130	51
125	71	130-140	11
135	23	140-150	1
145	3	150-160	0
155	0	160-170	0
165	0	170-180	0
175	0		
180	0		

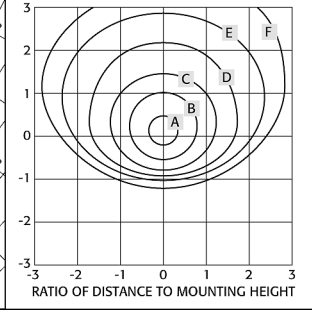

*Note: Photometric data was developed using (2) 32 watt compact fluorescent lamps (2,400 lumens each). For other lamp wattages, use the following conversion factors (multipliers) with both candlepower distribution and isofootcandle charts. Multipliers do not apply to coefficients of utilization.

LAMP WATTS	CONVERSION FACTOR
(2) 26 W (Fluor)	0.75
(1) 32 W (Fluor) Emergency	0.16
(2) 26W (Fluor) Emergency	0.13

LUMINAIRE SPACING RATIO - 2.3 (Spacing to mounting height ratio)
(For additional photometric data, contact Crouse-Hinds)

COEFFICIENTS OF UTILIZATION Effective Floor Cavity Reflectance 20%

Eff.	ROOM CAVITY RATIO												
	Ceil.	Wall	0	1	2	3	4	5	6	7	8	9	10
70*	64	55	48	43	39	35	32	30	27	25	23	21	19
50*	64	51	42	36	31	27	24	21	19	17	15	14	12
30*	64	47	37	31	25	21	18	16	14	12	11	10	9
10*	64	44	33	26	21	17	14	12	10	9	7	7	7
70*	61	52	45	41	37	33	30	28	25	24	22	21	20
50*	61	48	40	34	29	25	22	20	18	16	15	14	13
30*	61	45	35	29	24	20	17	15	13	11	10	9	8
10*	61	42	31	25	20	16	13	11	10	8	7	6	5
50*	54	43	35	30	26	22	20	18	16	14	13	12	11
30*	54	40	31	26	22	18	15	13	12	10	9	8	7
10*	54	38	28	22	18	14	12	10	9	7	6	5	4
50*	49	38	31	26	23	20	17	15	14	12	11	10	9
30*	49	36	28	23	19	16	14	12	10	9	8	7	6
10*	49	34	25	20	16	13	11	9	8	6	5	4	3
50*	44	35	27	23	20	17	15	13	12	11	10	9	8
30*	44	32	24	20	17	14	12	10	9	8	7	6	5
10*	44	30	22	18	14	11	9	8	7	5	4	3	2
0*	0*	41	28	20	16	12	10	8	6	5	4	3	2

*Percent Reflectance

Mtg. Hgt.	Footcandle Values for Isofootcandle Lines					
	A	B	C	D	E	F
10'	20.00	10.00	5.00	2.00	1.00	0.50
12'	13.88	6.94	3.47	1.39	0.69	0.35
16'	7.82	3.91	1.95	0.78	0.39	0.20
20'	5.00	2.50	1.25	0.50	0.25	0.13
25'	3.20	1.60	0.80	0.32	0.16	0.08

Isofootcandle chart shows illuminance in footcandles at ground level.



Low Profile Hazard•Gard® Luminaires

Luminaire with Globe and Dome (Less Guard)
EVL PFA03640RD Lamp: Two 32 W Compact Fluorescent

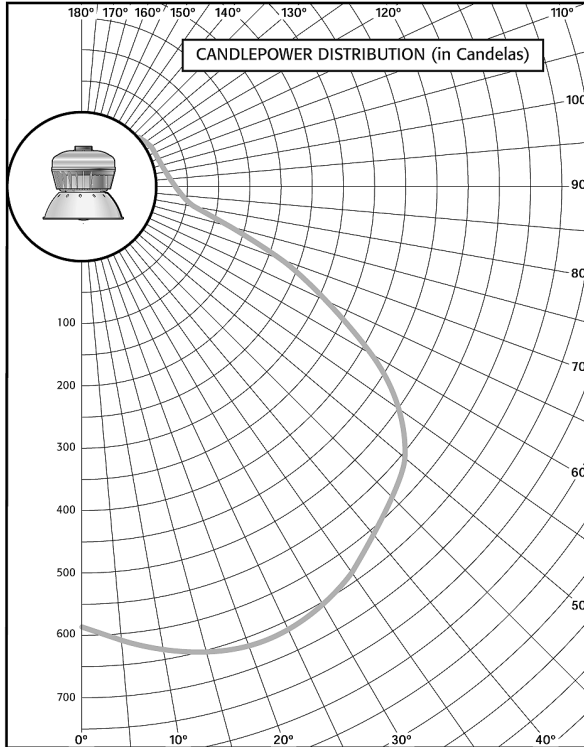

CANDELAS		ZONAL LUMENS	
Mid-Zone Angle	Candelas	Zone	Lumens
0	582	0-10	57
5	595	10-20	176
15	651	20-30	291
25	672	30-40	384
35	644	40-50	450
45	596	50-60	461
55	493	60-70	347
65	331	70-80	145
75	139	80-90	31
85	29	90-100	11
95	10	100-110	10
105	10	110-120	6
115	10	120-130	1
125	6	130-140	0
135	1	140-150	0
145	0	150-160	0
155	0	160-170	0
165	0	170-180	0
175	0		
180	0		

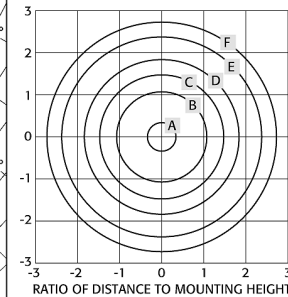

*Note: Photometric data was developed using (2) 32 watt compact fluorescent lamps (2,400 lumens each). For other lamp wattages, use the following conversion factors (multipliers) with both candlepower distribution and isofootcandle charts. Multipliers do not apply to coefficients of utilization.

LAMP WATTS	CONVERSION FACTOR
(2) 26 W (Fluor)	0.75
(1) 32 W (Fluor) Emergency	0.16
(2) 26 W (Fluor) Emergency	0.13

LUMINAIRE SPACING RATIO - 1.6 (Spacing to mounting height ratio)
(For additional photometric data, contact Crouse-Hinds)

COEFFICIENTS OF UTILIZATION
Effective Floor Cavity Reflectance 20%

		ROOM CAVITY RATIO										
Eff. Ceil.	Wall	0	1	2	3	4	5	6	7	8	9	10
80	70	59	54	49	45	41	37	34	31	28	26	24
	50	59	52	45	40	35	31	27	24	21	19	17
	30	59	50	42	36	31	26	23	20	17	15	13
	10	59	48	39	33	27	23	19	16	14	12	10
70	70	57	53	48	44	40	36	33	30	28	25	23
	50	57	51	44	39	34	30	27	24	21	19	17
	30	57	49	41	35	30	26	22	19	17	15	13
	10	57	47	39	32	27	23	19	16	14	12	10
50	50	55	48	42	37	33	29	26	23	20	18	16
	30	55	47	40	34	29	25	22	19	16	14	13
	10	55	45	38	32	27	22	19	16	14	12	10
30	50	52	46	41	36	32	28	25	22	20	17	16
	30	52	45	39	33	29	24	21	19	16	14	12
	10	52	44	37	31	26	22	19	16	14	12	10
10	50	50	44	39	35	31	27	24	21	19	17	15
	30	50	43	37	32	28	24	21	18	16	14	12
	10	50	43	36	30	26	22	18	16	13	11	10
0	0	49	41	35	29	25	21	17	15	12	11	9

*Percent Reflectance

ISOFOOTCANDLE CHART:

Footcandle Values for Isofootcandle Lines						
Mtg. Hgt.	A	B	C	D	E	F
10'	5.00	2.00	1.00	0.50	0.20	0.10
12'	3.47	1.39	0.69	0.35	0.13	0.07
16'	1.95	0.78	0.39	0.20	0.08	0.04
20'	1.25	0.50	0.25	0.13	0.05	0.03
25'	0.80	0.32	0.16	0.08	0.03	0.02

Isofootcandle chart shows illuminance in footcandles at ground level.

Luminaire with Globe and 30° Angle Reflector (Less Guard)
EVL PFA03640RA Lamp: Two 32 W Compact Fluorescent

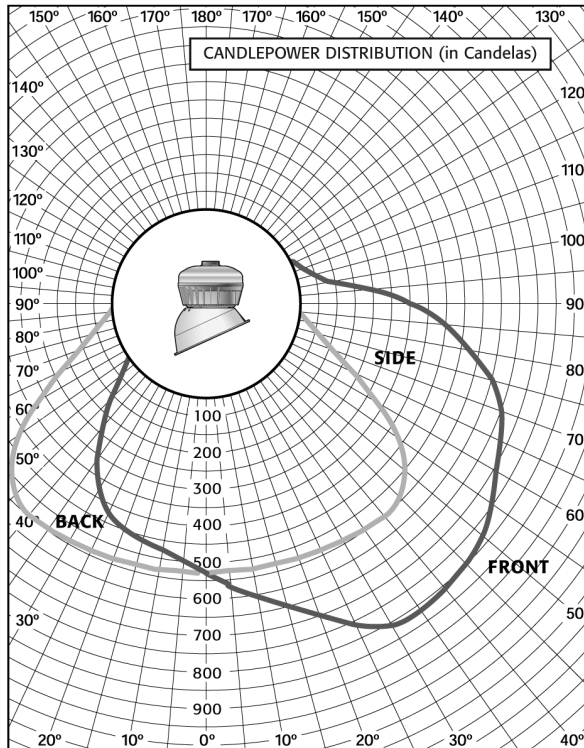

CANDELAS*			
Degrees	Front	Side	Back
0	524	524	524
5	565	526	487
15	637	528	452
25	751	541	425
35	816	550	315
45	798	551	157
55	749	453	18
65	684	258	1
75	605	93	1
85	450	20	9
95	260	10	9
105	99	10	9
115	18	9	9
125	0	1	9
135	0	0	1
145	0	0	0
155	0	0	0
165	0	0	0
175	0	0	0
180	0	0	0

ZONAL LUMENS	
Zone	Lumens
0-10	51
10-20	152
20-30	255
30-40	337
40-50	371
50-60	353
60-70	301
70-80	230
80-90	144
90-100	71
100-110	15
110-120	7
120-130	2
130-140	0
140-150	0
150-160	0
160-170	0
170-180	0

*Note: Photometric data was developed using (2) 32 watt compact fluorescent lamps (2,400 lumens each). For other lamp wattages, use the following conversion factors (multipliers) with both candlepower distribution and isofootcandle charts. Multipliers do not apply to coefficients of utilization.

LAMP WATTS	CONVERSION FACTOR
(2) 26 W (Fluor)	0.75
(1) 32 W (Fluor) Emergency	0.16
(2) 26 W (Fluor) Emergency	0.13

(For additional photometric data, contact Crouse-Hinds)

ISOFOOTCANDLE CHART:

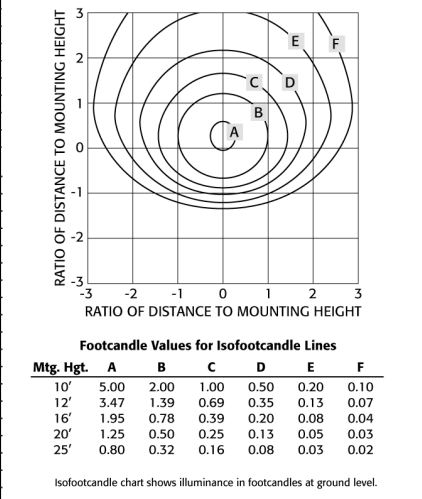

FVS Series Long Twin Tube

Fluorescent Luminaires

Cl. I, Div. 2, Groups B, C, D
Cl. II, Div. 1, Groups E, F, G
Cl. II, Div. 2, Groups F, G
Cl. III, Simultaneous Presence

Marine & Wet Locations
3, 3R, 4, 4X; IP66

5L

Applications:

FVS Compact Fluorescent Luminaires are used:

- Where low mounting heights or limited mounting room exists
- For task oriented lighting
- Where a cool, efficient light source is required
- In areas that require lamps to reach full illumination immediately
- In industrial and chemical processing
- In pulp and paper facilities
- In waste or sewage treatment facilities
- In non-hazardous commercial and industrial areas
- In food and pharmaceutical plants where a non-glass lens is required
- Where fluorescent lighting has been preferred, but unavailable due to limited space and practicality

Features:

- Compact, lightweight, low profile design is ideal for confined areas and tight corners
- Reaches full illumination immediately and delivers light output equivalent to fixtures twice its size
- Fast-Latch™ closure provides quick and easy access for relamping and maintenance – no tools necessary
- Silicone sealing gasket provides exceptional watertight and dust-tight bond, providing excellent performance in wet and corrosive environments
- Power disconnect switch (Eaton's Crouse-Hinds ESWP) automatically cuts power to the lamps and ballast when the lens is opened
- Shatter-resistant polymeric lens (0.125 thick) provides environmental and corrosion protection
- Available in UNV (120-277) and 347 50/60 Hz voltages
- Two lamp fixture, uses single-ended 40 watt lamps
- Multiple mounting capability
- Energy saving electronic ballast is standard

Standard Materials:

- Corrosion-resistant die cast copper-free aluminum housing
- Shatter-resistant nylon lens
- Polycarbonate lens (suffix -S813)
- Silicone rubber gasket
- Extruded aluminum hinges and closure hardware with stainless steel pivots

Standard Finishes:

- Epoxy powder coated housing
- Anodized hinges and closure hardware
- Highly specular aluminum reflector

Crouse-Hinds
by **EATON**



Certifications and Complies:

- NEC and CEC:
 - Class I, Division 2, Groups B, C, D
 - Class II, Division 1, Groups E, F, G (Suffix S813)
 - Class II, Division 2, Groups F, G
 - Class III & Simultaneous Presence (Cl. I and Cl. II)

Note: Aiming Limitations

- Cl. II, Cl. III & Simultaneous Presence
 - Aim down to Horizontal
 - Cannot aim up
- UL Standards
 - 844 Hazardous (Classified) Locations
 - 1598 Luminaires
 - 1598A Marine Locations
- CSA Standards
 - C22.2 No. 137

Options:

Description

- Fused to protect ballast under abnormal line conditions (not available on CSA certified fixtures) (not suitable for marine applications) **S658**
- Fixture supplied with two F40BX/SPX35 lamps **S714**
- Corro-free™ epoxy finish inside and out **S753**
- Tamperproof **Consult Eaton's Crouse-Hinds**

Temperature Performance Data:

Style	Ambient Temp °C	Class I, Div. 2	Class II See Aiming	Simultaneous Presence Limitations	Supply Wire	Minimum Operating Temperature
All	40°C	T3C	T6	T3C/T6	75°C	-18°C (0°F)
All	55°C	T3C	—	—	75°C	-18°C (0°F)

Luminaire Weight:

Without Lamps

Type	lbs.
Standard 2 lamp FVS	12.0

Size Ranges:

- All luminaires are 24" L x 12" W x 3.12" H
- Conduit entrances are 3/4"

Electrical Ratings:

- UNV (120–277V), 50–60 Hz
- 347V, 60 Hz
- Two 40 watt long twin tube lamps

Accessories

FVS Trunnion Mount Kit (FVS-K5)

- Permits vertical mounting of luminaire on a beam when used with a standard beam clamp
- Can be mounted directly to a wall or ceiling
- Can be pole mounted when used in conjunction with a SFA6 slipfitter adapter (ordered separately)
- Constructed from copper-free aluminum
- Supplied with a CGB cord connector

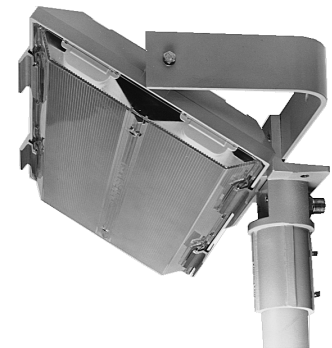

FVS with Trunnion Arm and Slipfitter

5L

5L

FVS Series Long Twin Tube

Fluorescent Luminaires

Cl. I, Div. 2, Groups B, C, D
Cl. II, Div. 1, Groups E, F, G
Cl. II, Div. 2, Groups F, G
Cl. III, Simultaneous Presence

Marine & Wet Locations
3, 3R, 4, 4X; IP66

Luminaire includes all necessary provisions for these installations:



Ceiling Mount



Pendant Mount



Corner Mount



Horizontal Wall Mount



Vertical Wall Mount

FVS compact fluorescent (2 lamp luminaire):

Voltage	Wattage/ Lamp	Hub Size (4)	Cat. #	Cat. # with Class II, Div. 1 Suitability
120-277 (50 or 60 Hz)	40	3/4"	FVS20/UNV	FVS20/UNV S813
347 (50 or 60 Hz)	40	3/4"	FVS23	FVS23 S813

Accessories (Ordered Separately):

Description	Cat. #
• Trunnion arm kit	FVS K5
• Slipfitter adapter to be used with trunnion arm	SFA6

Dimensions:

FVS with Trunnion Arm: 26 1/4" x 13.5" W x 3.12" H

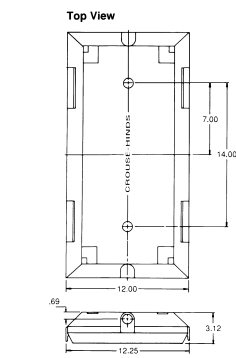

Top View

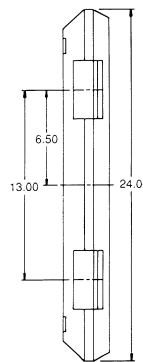

Side View

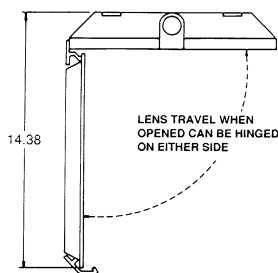
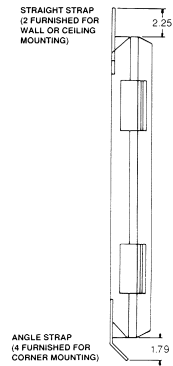

FVS With Lens Open

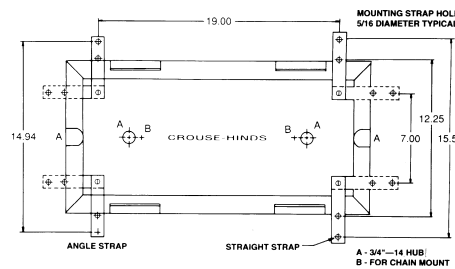

FVS Showing
Mounting Strap Positioning

5L

FVS Series Long Twin Tube

Photometric Data

5L

Fluorescent Luminaires

Luminaire: FVS

Lamp: (2) F40BX/SPX35/RS single-ended fluorescent.

Total initial lumens: 6300

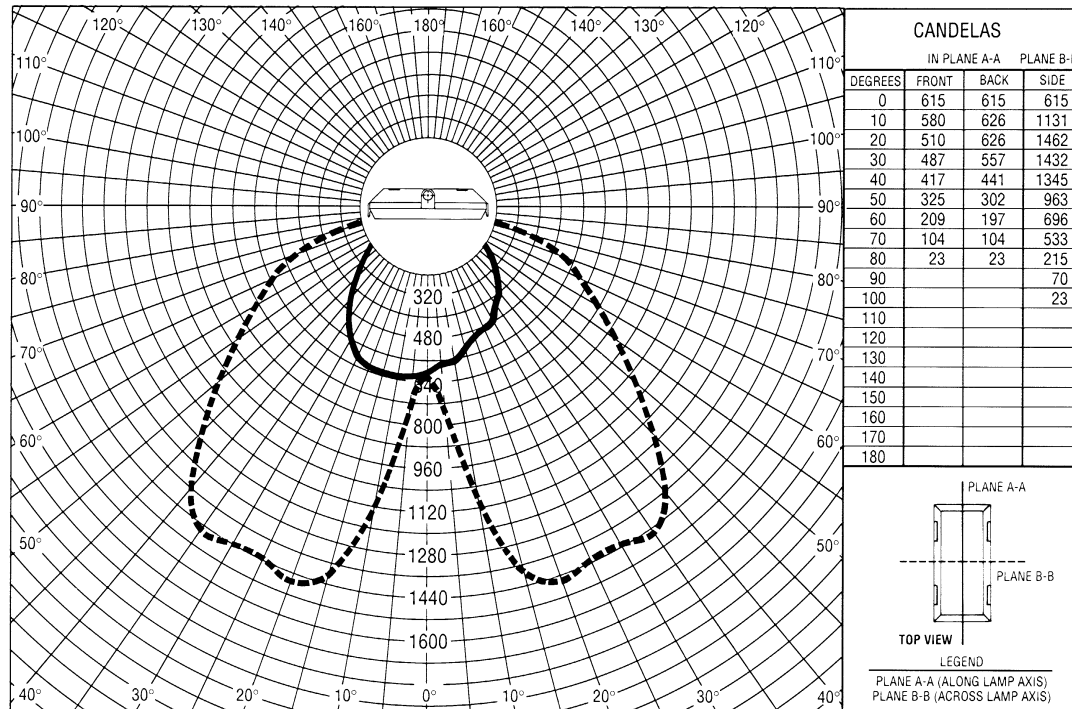

Isofootcandle Chart

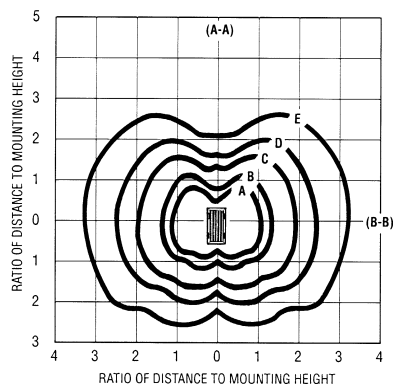

Footcandle Values for Isofootcandle Lines

Mtg. Hgt.	A	B	C	D	E
8'	5.00	3.00	1.00	0.50	0.20
10'	3.20	1.92	0.64	0.32	0.13
12'	2.22	1.33	0.44	0.22	0.09
16'	1.25	0.75	0.25	0.13	0.05

Spacing to Mounting Height Ratio

Along lamp axis (A-A)	0.6
Across lamp axis (B-B)	1.1

Coefficients of Utilization

Effective Floor Cavity Reflectance 20%

Eff. Ceil.	Wall	Room Cavity Ratio									
		1	2	3	4	5	6	7	8	9	10
80*	50*	.621	.538	.469	.414	.367	.329	.297	.269	.246	.225
	30*	.594	.495	.419	.359	.312	.273	.242	.216	.195	.176
	10*	.569	.459	.378	.317	.270	.234	.204	.180	.160	.144
70*	50*	.606	.526	.459	.405	.360	.323	.291	.265	.242	.222
	30*	.582	.487	.412	.354	.308	.270	.240	.214	.193	.175
	10*	.560	.453	.374	.314	.268	.232	.203	.179	.160	.143
50*	50*	.580	.503	.441	.389	.347	.311	.281	.256	.234	.216
	30*	.560	.470	.400	.345	.300	.265	.235	.210	.190	.172
	10*	.541	.442	.367	.310	.265	.230	.201	.178	.159	.143
30*	50*	.555	.483	.423	.374	.334	.301	.272	.248	.227	.210
	30*	.539	.455	.389	.336	.293	.259	.230	.207	.187	.170
	10*	.524	.431	.360	.305	.262	.227	.199	.176	.157	.142
10*	50*	.533	.464	.407	.361	.322	.290	.264	.241	.221	.204
	30*	.520	.441	.378	.327	.287	.254	.226	.203	.184	.167
	10*	.507	.421	.353	.300	.258	.225	.197	.175	.156	.141
0*	0*	.494	.407	.339	.286	.245	.212	.185	.163	.145	.130

*Percent Reflectance.

†FVS suitable for Class II, Div. 1, Groups E, F, G when ordered with suffix S813.

EVFT Illuminator™ Long Twin Tube

Fluorescent Luminaires

Cl. I, Div. 1, Groups B & C (suffix GB), D
Cl. I, Zone 1, Group IIB + H₂ (suffix GB), IIA
Cl. II, Div. 1, Groups E, F, G
Cl. III Simultaneous Presence

Paint Spray
Marine & Wet Locations
3, 3R, 4, 4X; IP66

Applications:

Illuminator™ Compact Fluorescent Luminaires are used:

- In areas made hazardous by the presence of flammable gases and vapors, combustible dusts, or easily ignitable fibers and flyings
- In areas where combustible dusts and flammable gases are present simultaneously
- In applications involving low mounting heights, restricted mounting space, or where luminaire weight must be minimized
- In areas where corrosion, vibration, moisture, dirt, and rough usage are a problem
- In refineries, chemical and petrochemical facilities, grain processing, handling and storage facilities, manufacturing plants, wastewater treatment facilities, airline and mass transit maintenance areas, paint spray facilities, breweries, pharmaceutical plants, and other areas where safe, reliable hazardous area lighting is required in a compact, cool operating and efficient light source

Features:

- Efficient fluorescent light source in 78 and 156 watts
- Adjustable right and left asymmetrical reflectors provide excellent light "aimability" – ideal for task oriented lighting
- Compact, lightweight, and low profile design allows easy installation and broad industrial application
- Cast copper-free aluminum with epoxy powder finish (less than 0.4 of 1% copper) provides excellent resistance to corrosion
- Versatile luminaire housing provides choice of pendant, wall, or ceiling mount
- Suitable for paint spray areas; linear light source provides excellent color rendition for paint spray tasks; easy to install, disposable, clear tube wrap helps maintain maximum light output during painting operations
- Threaded construction, factory wiring and sealing help minimize installation time; no external seals are required
- Fixtures are used with two or four long twin tube single-ended fluorescent lamps
- Optional stainless steel guard provides extra protection for lamps and lamp tube
- Optional clear polycarbonate tube provides 360° protection for lamps and lamp tube; ideal for maintenance pit and pharmaceutical applications
- Grounding connection for safety
- Available for 120 or 277 VAC
- Standard electronic ballast

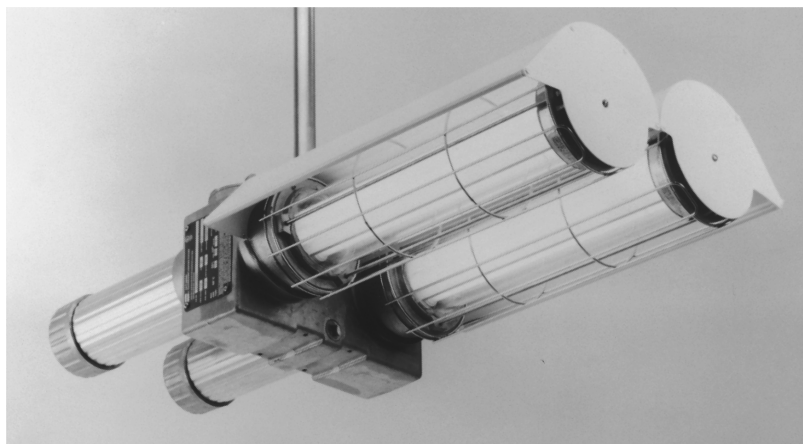

4 lamp with stainless steel wire guard and adjustable reflectors

Certifications and Complies:

- NEC and CEC:
 - Class I, Division 1, Group D
 - Class I, Division 1, Group B, C, D (suffix GB)
 - Class I, Zone 1, Group IIA
 - Class I, Zone 1, Group IIB + H₂ (suffix GB)
 - Class II, Groups E, F, G
 - Class III
 - Simultaneous Presence (Cl. I and Cl. II)
 - Paint Spray

Note: Aiming Limitations

- Cl. II, Cl. III & Simultaneous Presence
 - Aim Down to Horizontal
 - Cannot aim up
- UL Standards:
 - 844 Hazardous (Classified) Locations
 - 1598 Luminaires
 - 1598A Marine Locations
- CSA Standards:
 - C22.2 No. 137

Standard Materials:

- Center and ballast housings, end caps – copper-free aluminum
- Lamp tube – heat-resistant glass
- Guards – stainless steel or clear polycarbonate material
- Reflectors – aluminum

Standard Finishes:

- Center and ballast housings, end caps, guards – natural
- Reflectors – white epoxy finish

Temperature Performance Data:

Luminaire Type	Minimum Operating Temp.	Maximum Ambient Temp.	Class I, Division 1 & Zone 1 Class II, Division 1 Simultaneous Presence	Supply Wire
2 and 4 Lamp	10°C (50°F)	40°C (104°F)	T4A	75°C

Options:

Description	Suffix
Fused to protect circuit under abnormal conditions (not available on CSA certified luminaires) (not suitable for marine applications)	S658
Luminaire supplied with lamps	S714
Class I, Groups B and C suitability pendant mount only	GB

Electrical Ratings:

- Input voltage – 120 or 277 VAC, 60 Hz
- Wattages – 78 – 2 lamp luminaire
156 – 4 lamp luminaire

Fixture Weights

Illuminator	lbs.
2 lamp with guard	19.5
4 lamp with guards	36.5
RAL1, RAR1 reflectors (each)	3.0
Deduct for luminaire without P51 Guard:	
1 lb. for 2 lamp	
2 lbs. for 4 lamp	

EVFT Illuminator™ Long Twin Tube

Fluorescent Luminaires

Cl. I, Div. 1, Groups B & C (Suffix B), D
Cl. I, Zone 1, Groups IIB + H₂
(Suffix B), IIA
Cl. II, Div. 1, Groups E, F, G
Cl. III, Simultaneous Presence

Paint Spray
Marine & Wet Locations
3, 3R, 4, 4X; IP66

5L

Ordering Information:

Style	Hub Size (In.)	Luminaire Voltage	Class I Cat. # with Group D Suitability		Class I Cat. # with Group B, C & D Suitability	
			Without Guard	With P51 Guard†	Without Guard	With P51 Guard†
2 Lamp	3/4	120	EVFT22320	EVFT22321	EVFT22320 GB	EVFT22321 GB
		277	EVFT22370	EVFT22371	EVFT22370 GB	EVFT22371 GB
4 Lamp	3/4	120	EVFT24320	EVFT24321	EVFT24320 GB	EVFT24321 GB
		277	EVFT24370	EVFT24371	EVFT24370 GB	EVFT24371 GB

†P51 supplied in separate carton.

Accessories:

Type	Cat. #
• Stainless steel wire guard.....	P51
• Reflector right hand	RAR1
• Reflector left hand.....	RAL1
• Polycarbonate tube (not used with optional stainless steel wire guard)	PG1
• Disposable clear wrap – 5 pack (for use with optional polycarbonate tube).....	PTW1

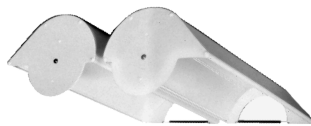

RAL1 RAR1
Reflectors (as viewed facing front of fixture)

Note: For 4 lamp unit, you must order one of each reflector, if required.

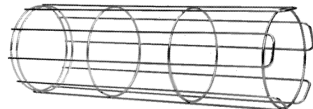

Stainless steel guard

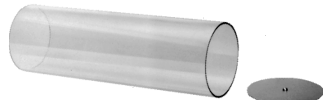

Polycarbonate tube and retaining plate

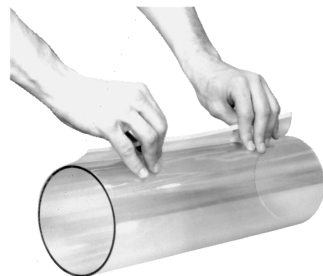

Disposable polyester tube wrap (used over optional polycarbonate tube)

Aiming Limitations:

In Class II, Class III and Simultaneous Presence locations

- Aim down to horizontal
- To prevent dust from accumulating in reflector, do not aim up
- The Illuminator lighting fixtures are designed for operation with the lamp in a **horizontal to base down position**

Dimensions:

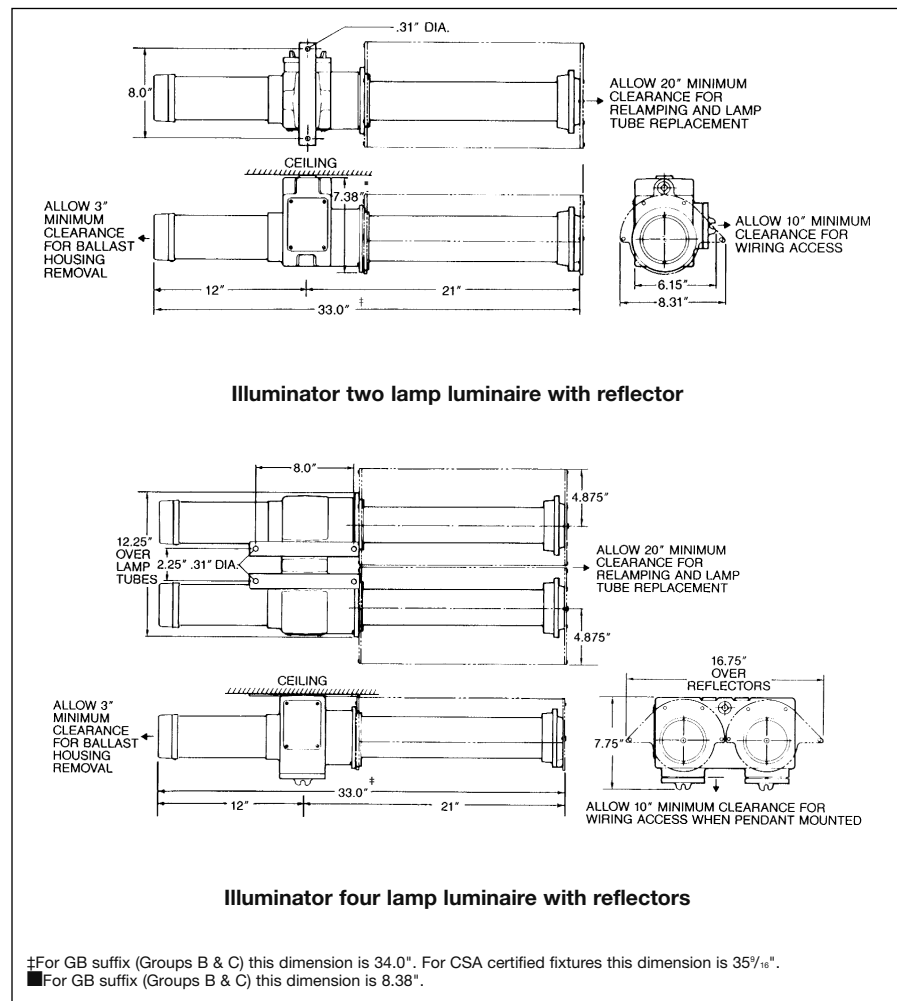

Fluorescent Luminaires

Illuminator two lamp luminaire with reflector (without guard)

Lamps: Two 39 watt BIAx* fluorescent

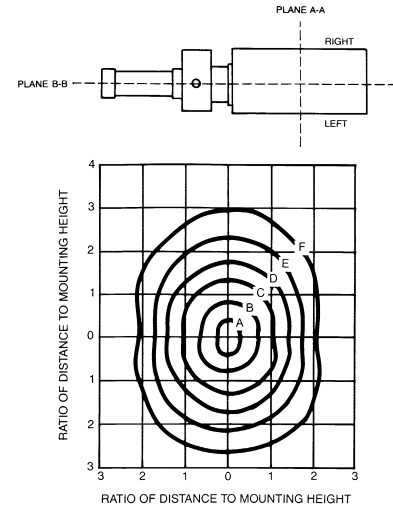
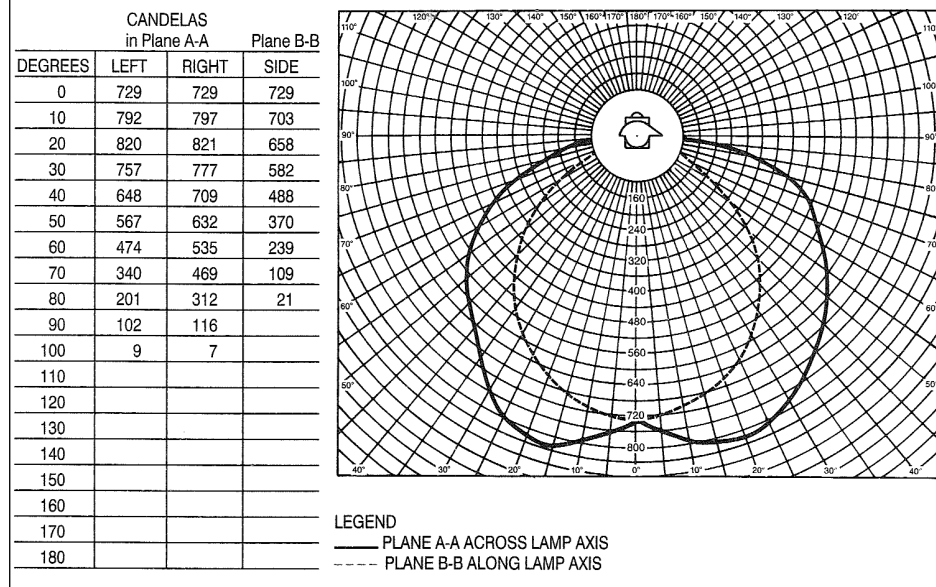

Footcandle Values for Isofootcandle Lines

Mtg. Ht. (ft.)	A	B	C	D	E	F
8	10.0	5.00	2.00	1.00	0.50	0.25
10	6.4	3.20	1.28	0.64	0.32	0.16
12	4.4	2.22	0.89	0.44	0.22	0.11
16	2.5	1.25	0.50	0.25	0.13	0.06

Illuminator four lamp luminaire with reflectors (without guards)

Lamps: Four 39 watt BIAx* fluorescent

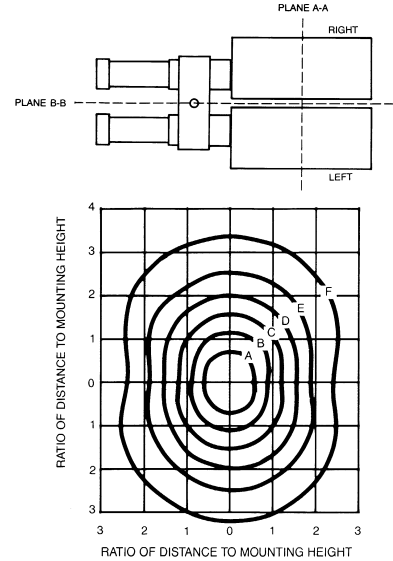
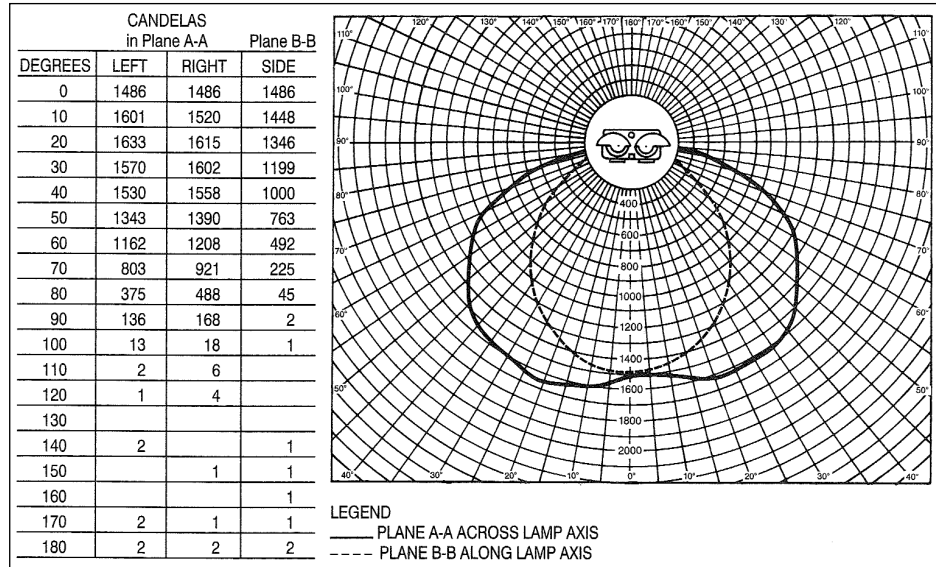

Footcandle Values for Isofootcandle Lines

Mtg. Ht. (ft.)	A	B	C	D	E	F
10	8.0	4.00	2.00	1.00	0.50	0.20
12	5.6	2.78	1.39	0.69	0.35	0.14
16	3.1	1.56	0.78	0.39	0.20	0.08
20	2.0	1.00	0.50	0.25	0.13	0.05

*BIAx is a trademark of the General Electric Company.

EVFT Illuminator™ Long Twin Tube

Coefficients of Utilization

5L

Fluorescent Luminaires

Luminaire: EVFT 22320 with RAR1 Reflector
Lamps: Two F39BX/SPX35/RS
Lumen Rating: 2900 Lumens/Lamp

Effective Floor Cavity Reflectance 20%

% Reflectance Eff. Ceil.	Wall	Room Cavity Ratio										
		0	1	2	3	4	5	6	7	8	9	10
80	70	.51	.46	.41	.38	.34	.31	.29	.26	.24	.22	.21
	50	.51	.44	.38	.33	.29	.25	.23	.20	.18	.16	.15
	30	.51	.41	.35	.29	.25	.21	.19	.16	.14	.13	.11
	10	.51	.40	.32	.26	.22	.18	.16	.14	.12	.10	.09
70	70	.49	.45	.40	.37	.33	.30	.28	.26	.24	.22	.20
	50	.49	.43	.37	.32	.28	.25	.22	.20	.18	.16	.14
	30	.49	.41	.34	.29	.25	.21	.18	.16	.14	.12	.11
	10	.49	.39	.31	.26	.22	.18	.16	.14	.12	.10	.09
50	50	.47	.41	.35	.31	.27	.24	.21	.19	.17	.15	.14
	30	.47	.39	.33	.28	.24	.21	.18	.16	.14	.12	.11
	10	.47	.38	.31	.26	.22	.18	.16	.13	.12	.10	.09
30	50	.45	.39	.34	.30	.26	.23	.21	.19	.17	.15	.14
	30	.45	.38	.32	.27	.24	.20	.18	.16	.14	.12	.11
	10	.45	.37	.30	.25	.21	.18	.15	.13	.11	.10	.09
10	50	.43	.37	.33	.29	.25	.22	.20	.18	.16	.14	.13
	30	.43	.36	.31	.27	.23	.20	.17	.15	.13	.12	.10
	10	.43	.35	.29	.25	.21	.18	.15	.13	.11	.10	.08
0	0	.43	.35	.28	.24	.20	.17	.14	.12	.10	.09	.08

DETERMINED IN ACCORDANCE WITH CURRENT IES PUBLISHED PROCEDURES

Luminaire: EVFT 24320 with RAR1 & RAL1 Reflectors
Lamps: Four F39BX/SPX35/RS
Lumen Rating: 2900 Lumens/Lamp

Effective Floor Cavity Reflectance 20%

% Reflectance Eff. Ceil.	Wall	Room Cavity Ratio										
		0	1	2	3	4	5	6	7	8	9	10
80	70	.48	.44	.40	.37	.33	.30	.28	.26	.24	.22	.20
	50	.48	.42	.37	.32	.29	.25	.22	.20	.18	.16	.15
	30	.48	.40	.34	.29	.25	.21	.19	.16	.14	.13	.11
	10	.48	.39	.31	.26	.22	.19	.16	.14	.12	.10	.09
70	70	.47	.43	.39	.36	.33	.29	.27	.25	.23	.21	.20
	50	.47	.41	.36	.32	.28	.25	.22	.20	.18	.16	.14
	30	.47	.40	.33	.29	.25	.21	.18	.16	.14	.12	.11
	10	.47	.38	.31	.26	.22	.18	.16	.14	.12	.10	.09
50	50	.45	.39	.34	.30	.27	.24	.21	.19	.17	.15	.14
	30	.45	.38	.32	.28	.24	.21	.18	.16	.14	.12	.11
	10	.45	.37	.30	.26	.22	.18	.16	.14	.12	.10	.09
30	50	.43	.38	.33	.29	.26	.23	.20	.18	.17	.15	.14
	30	.43	.37	.31	.27	.23	.20	.18	.16	.14	.12	.11
	10	.43	.36	.30	.25	.21	.18	.16	.13	.12	.10	.09
10	50	.41	.36	.32	.28	.25	.22	.20	.18	.16	.14	.13
	30	.41	.35	.30	.26	.23	.20	.17	.15	.13	.12	.11
	10	.41	.35	.29	.25	.21	.18	.15	.13	.12	.10	.09
0	0	.41	.34	.28	.24	.20	.17	.15	.13	.11	.09	.08

DETERMINED IN ACCORDANCE WITH CURRENT IES PUBLISHED PROCEDURES



Applications:

The NFL Light Luminaires are used:

- In hazardous locations where dust, dirt, combustible vapors, smoke, fumes, moisture, corrosive, and wet conditions are present
- Where lamps may be broken due to physical abuse or movable equipment, such as in manufacturing areas or warehouses
- Where cleanliness and sanitation are prime factors such as in dairies, canneries, food processing plants, bottling plants, and laboratories
- In dock areas for protection against salt spray
- In areas where low mounting height and the even light distribution associated with a line type light source are required

Key Features:

- UL, cUL Listed for Class I, Division 2, Groups A, B, C, D areas with ambient suitability of 40°C (104°F) and 55°C (131°F) ambient suitability
- NEMA 4X with Myers Hubs and threaded metal plug (furnished)
- Non-metallic construction enclosure is corrosion-resistant
- Continuous form-in-place gasket ensures dust-tight, moisture-tight, and wet locations integrity
- Molded-in-place mounting studs – eliminate the need of bracket gaskets
- Standard construction includes:
S.S. mounting brackets
Electronic ballast
Cold weather ballast (4' F32 T8)
- S.S. mounting bracket combination ceiling and chain
- S.S. mounting brackets provide superior corrosion resistance
- Electronic ballast for energy efficiency
- Cold Weather Ballast (4' F32 T8)
- Two ½" conduit Myers Hubs for end and feed through wiring simplify installation and wiring
- Full metal fixture interior provides improved photometrics as well as access to and concealment of ballast and wiring
- Provisions (drill mark) on 4 ft. unit to field drill for pendant mounting for application and installation flexibility



Standard Materials:

- Housing – non-metallic, one piece fiberglass-reinforced polyester
- Latches – Celcon™ acetal plastic
- Lens – acrylic plastic
- Gaskets – seamless thermoset polyurethane
- Mounting Bracket – stainless steel

Celcon™ is a trade name of Hoechst Celanese.

Standard Finishes:

- Fiberglass housing – white
- Acrylic plastic lens – crepe pattern

Options:

Description	Suffix
• Fused (not suitable for marine applications).....	S658
• Factory assembled with lamps installed	FA
• Battery back-up emergency ballast† (NFL 2140 and NFL 4232 only)....	S799*
• Increased impact-resistant lens (acrylic crepe pattern)..	DR1295046*
• Stainless steel latches	S863*
• Tamperproof latches.....	S861*

†For non-hazardous locations.
*UNV voltages: 120, 208, 230, 240, 277, 50-60 Hz.

Ratings (Electrical/Size):

Sources/Wattage: luminaires are for use with the following lamps

- NFL2140
one 40 W long twin tube
- NFL4232
two 32W T8 lamps
- NFL4240
two 34W "F40 Style" T12 lamps

Voltages

- 120V 60Hz
- 120 – 277V, 50 – 60 Hz
- 347V 60 Hz

Conduit Entries

- Two ½" inch Myers hubs, one on each end

Temperature Performance Data:

Ambient temperature range suitability:	°C
Two lamp, 32W T8, 4 ft luminaire	-18°C to 55°C
All others	0°C to 55°C
Supply wire	75°C min.

Ordering Information:

Luminaire Cat. #	Size/# of Lamp(s)	Wattage/ Lamp type	Voltage/Hz
NFL2140/UNV	2 ft/ 1-lamp	40W T5 compact	120 / 60
NFL2140/347		single ended	120-277/50-60 347 / 60
NFL4232/UNV	4 ft/2-lamp	32W T8 rapid start	120 / 60 120-277/50-60
NFL4240/120	4ft/2-lamp	34W T12	120 / 60
NFL4240/277		"F40 Style"	277 / 60
NFL4240/347		rapid start	347 / 60
N2FL4232/UNV N2FL4232/347	4ft/2-lamp	32W T8 rapid start	347 / 60

Luminaire: All NFL Luminaires

Candlepower Distribution Curve (in Candelas)

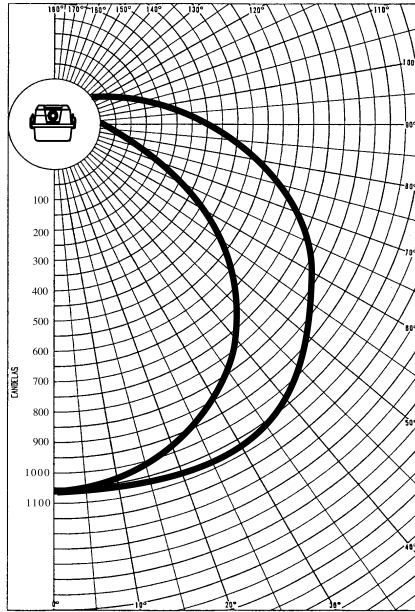

Candelas Angle	Along	Across
0°	1049	1049
10°	1034	1056
20°	978	1071
30°	866	1075
40°	762	1027
50°	606	939
60°	416	838
70°	228	723
80°	92	549
90°	17	363
100°	19	243
110°	10	131
120°	5	46
130°	4	20
140°	4	9
150°	4	3
160°	4	0
170°	0	0
180°	0	0

Zonal Lumens

Zone	Lumens
0-30	862
0-40	1462
0-60	2778
0-90	4130
0-180	4499

Photometric data, developed using two (2) F32T8/35K 2850 lumen lamps, represents the performance of all NFL series luminaires.

- Coefficient of Utilization – These values are for all NFL series luminaires (Do not use multipliers).
- Candlepower Distribution Curve (in candelas) and Zonal Lumens – These values are for all NFL series luminaires, adjusted by conversion factors (multipliers) below.

Example:

- Candlepower at 20° across for NFL4232 using two (2) F32T/35K lamps (5700 lumen total) is 1071 candelas.
- Candlepower at 20° across for NFL2140 using one (1) T5 compact lamp (3100 lumen total) is 1071 x .55 = 589 candelas.

Luminaire Series	Lamp		Type (Lumens ea.)	Conversion Factor (multipliers)
	Qty	Watts		
NFL2140	2	32	F32T8/35K (2850)	1.0
NFL4232	2	34	F40T12/RS (2650)	0.93
NFL4240	1	40	T5 Compact (3150)	0.55

Coefficient of Utilization: For all NFL Series Light Luminaires

Effective Floor Cavity Reflectance 20%

% Reflectance Eff. Ceiling	Wall	Room Cavity Ratio									
		1	2	3	4	5	6	7	8	9	10
80	70	.83	.75	.68	.62	.56	.51	.47	.44	.40	.37
	50	.78	.67	.59	.52	.45	.40	.36	.32	.29	.26
	30	.74	.61	.52	.44	.38	.33	.29	.25	.22	.20
	10	.71	.56	.46	.39	.32	.28	.24	.20	.17	.15
70	70	.80	.72	.65	.59	.54	.49	.46	.42	.39	.36
	50	.76	.65	.57	.50	.44	.39	.35	.31	.28	.26
	30	.72	.60	.51	.43	.37	.32	.28	.25	.22	.19
	10	.69	.55	.46	.38	.32	.27	.23	.20	.17	.15
50	50	.71	.61	.54	.47	.42	.37	.33	.30	.27	.24
	30	.68	.57	.48	.42	.35	.31	.27	.24	.21	.19
	10	.66	.53	.44	.37	.31	.26	.23	.20	.17	.15
	30	50	.67	.58	.51	.45	.39	.35	.32	.28	.25
30		.65	.54	.46	.40	.34	.30	.26	.23	.20	.18
10		.62	.51	.42	.36	.30	.26	.22	.19	.16	.14
10		50	.63	.54	.48	.42	.37	.33	.30	.27	.24
	30	.61	.51	.44	.38	.33	.29	.25	.22	.19	.17
	10	.59	.48	.41	.35	.29	.25	.22	.18	.16	.14
	0	0	.57	.46	.39	.33	.27	.23	.20	.17	.14



5L NFL Series Fluorescent Luminaires

Dimensions and Weights

Dimensions:

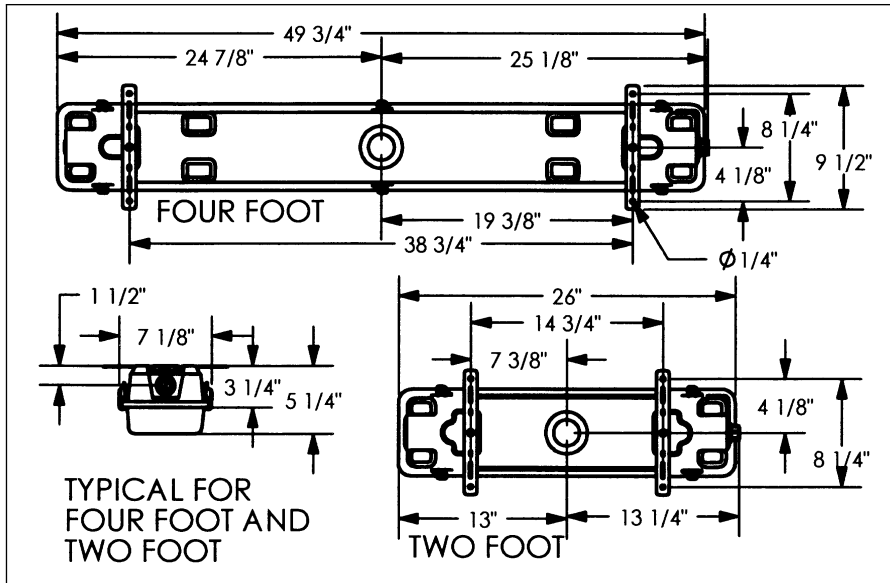

Net Luminaire Weights

Luminaire Series	Weight (lbs.)
NFL2140	9.1
NFL4232	14.3
NFL4240	14.3

Temperature Performance Data:

Cat. No.	Watts	Ambient Temp. °C	Lamp Type	Supply Wire Temp. °C	Class I, Div. 2 Temp. Rating	Class II Temp. Rating	Simultaneous Presence Class I, Div. 2
NFL4232	32	40	T8	60	T6	-	-
NFL4232	32	55	T8	75	T5	-	-
NFL4240	34	40	T12	60	T6	-	-
NFL4240	34	55	T12	75	T5	-	-
NFL2140	40	40	T12	60	T6	-	-
NFL2140	40	55	T12	75	T5	-	-

5L

eLLK Series™ Fluorescent Non-metallic Luminaires

Cl. I, Div. 2, Groups B, C, D
Cl. I, Zone 1, Group IIC
Cl. II, Div. 1, Groups E, F, G (Canada)
Cl. II, Div. 2, Groups F, G (US)
Cl. III, Simultaneous Presence

Wet Locations
3, 3R, 4, 4X; IP66
ATEX Certified

5L

Applications:

- eLLK Fixtures are used in hazardous areas where moisture or corrosion may be a problem
- Offshore oil platforms, pharmaceuticals, plants, oil refineries
- Where battery back-up is critical
- In non-hazardous and industrial locations

Features:

- IEC: Zone 1 and 2 areas
 - NEC/CEC: Zone 1, Division 2 areas
- Electronic Ballast:
- Operates at voltage range of 110–254 VAC ± 10%, 50–60 Hz
 - Wide ambient temperature range suitability -25°C to +55°C (eLLK92), -25°C to +50°C (eLLK92NIB)
 - Lamps operate independently – one lamp failure will not affect remaining lamp operation
 - Standard bi-pin lamps – most common lamp used in office environments; energy-efficient and cost effective
 - Interlocked switch – automatically cuts power to both lamps and ballast when the lens is opened
 - Removable lens – hinged on both sides for easy installation and maintenance
 - Dual entries– extra large wire well eliminates need for separate junction boxes (own with cable gland and conduit hub)
 - Corrosion-resistant construction - non-metallic body, gasketed lenses, and lens locking system for an IP66, NEMA 4X rating
- Battery Back-up Features:
- Operates one lamp for 1½ hours should power go out
 - Microprocessor monitors the charging functions of the battery
 - LEDs provide visual indication of battery life



Certifications and Compliances:

- NEC and CEC:
 - Class I, Division 2, Groups B, C, D
 - Class I, Zone 1, Group IIC
 - Class II, Division 1, Groups E, F, G (Canada)
 - Class II, Division 2, Groups F, G (US)
 - Class III, Simultaneous Presence (Cl. I and Cl. II)
- UL Standards:
 - 1598 Luminaires
- CSA Standards:
 - E79 Series
- ATEX Directive 94/9/EC:
 - Ex II 2 G Ex de IIC T4
 - Ex II 2 D Ex tD A21 IP66 T80°C
- EC-Type Examination Certificate:
 - BVS 09 ATEX E034
- GOST-R, GOST-K

5L

5L

eLLK Series™ Fluorescent Non-metallic Luminaires

Cl. I, Div. 2, Groups B, C, D
 Cl. I, Zone 1, Group IIC
 Cl. II, Div. 1, Groups E, F, G (Canada)
 Cl. II, Div. 2, Groups F, G (US)
 Cl. III, Simultaneous Presence

Wet Locations
 3, 3R, 4, 4X; IP66
 ATEX Certified

Ordering Information:

Cat. #	Description	Length & Lamp Type	Lamp Watt - 2 Lamp	Rated Voltage	Rated Current	Conduit Hub Size*	Comments
NEC (NOT ATEX CERTIFIED)							
1 2265 875 309	eLLK 92 2217 /U240 1/6 2 NPT 3/4"	2-foot T8 NEC	17W	120V-240V, 50-60 Hz, 120-230 DC	0.38-0.18A	2 ea. - 3/4" Myers hub	No through-feed
1 2265 875 310	eLLK 92 2217 /U240 1/6 2 NPT 1/2"	2-foot T8 NEC	17W	120V-240V, 50-60 Hz, 120-230 DC	0.38-0.18A	2 ea. - 1/2" Myers hub	No through-feed
1 2265 875 311	eLLK 92 2217 /U240 2/6 2 NPT 3/4"	2-foot T8 NEC	17W	120V-240V, 50-60 Hz, 120-230 DC	0.38-0.18A	4 ea. - 3/4" Myers hub	Through-feed
1 2266 875 309	eLLK 92 4232 /U240 1/6 2 NPT 3/4"	4-foot T8 NEC	32W	120V-240V, 50-60 Hz, 120-230 DC	0.7-0.34A	2 ea. - 3/4" Myers hub	No through-feed
1 2266 875 310	eLLK 92 4232 /U240 1/6 2 NPT 1/2"	4-foot T8 NEC	32W	120V-240V, 50-60 Hz, 120-230 DC	0.7-0.34A	2 ea. - 1/2" Myers hub	No through-feed
1 2266 875 311	eLLK 92 4232 /U240 2/6 2 NPT 3/4"	4-foot T8 NEC	32W	120V-240V, 50-60 Hz, 120-230 DC	0.7-0.34A	4 ea. - 3/4" Myers hub	Through-feed
1 2260 879 333	eLLK 92NIB 2217 /U120 2/6 2 NPT 3/4"	2-foot T8 NEC	17W (with battery)	120V, 50-60 Hz, 120-230 DC	0.38A	4 ea. - 3/4" Myers hub	Through-feed
1 2260 879 311	eLLK 92NIB 2217 /U240 2/6 2 NPT 3/4"	2-foot T8 NEC	17W (with battery)	240V, 50-60 Hz, 120-230 DC	0.18A	4 ea. - 3/4" Myers hub	Through-feed
1 2261 879 333	eLLK 92NIB 4232 /U120 2/6 2 NPT 3/4"	4-foot T8 NEC	32W (with battery)	120V, 50-60 Hz, 120-230 DC	0.7A	4 ea. - 3/4" Myers hub	Through-feed
1 2261 879 311	eLLK 92NIB 4232 /U240 2/6 2 NPT 3/4"	4-foot T8 NEC	32W (with battery)	240V, 50-60 Hz, 120-230 DC	0.34A	4 ea. - 3/4" Myers hub	Through-feed
IEC (ATEX CERTIFIED)							
1 2265 875 109	eLLK 92 018/18 1/6-1 M	2-foot T8 IEC	18W	120V-240V, 50-60 Hz	0.38-0.18A	2 ea. - 20mm metric	No through-feed
1 2265 875 111	eLLK 92 018/18 2/6-2 M	2-foot T8 IEC	18W	120V-240V, 50-60 Hz	0.38-0.18A	4 ea. - 20mm metric	Through-feed
1 2266 875 109	eLLK 92 036/36 1/6-1 M	4-foot T8 IEC	36W	120V-240V, 50-60 Hz	0.7-0.34A	2 ea. - 20mm metric	No through-feed
1 2266 875 111	eLLK 92 036/36 2/6-2 M	4-foot T8 IEC	36W	120V-240V, 50-60 Hz	0.7-0.34A	4 ea. - 20mm metric	Through-feed
1 2260 879 109	eLLK 92 018 /18NIB 1/6-1 M	2-foot T8 IEC	18W (with battery)	240V, 50-60 Hz	0.18A	2 ea. - 20mm metric	No through-feed
1 2260 879 111	eLLK 92 018 /18NIB 2/6-2 M	2-foot T8 IEC	18W (with battery)	240V, 50-60 Hz	0.18A	4 ea. - 20mm metric	Through-feed
1 2260 879 409	eLLK 92 018 /18NIB 1/6-1 M	2-foot T8 IEC	18W (with battery)	120V, 50-60 Hz	0.38A	2 ea. - 20mm metric	No through-feed
1 2260 879 411	eLLK 92 018 /18NIB 2/6-2 M	2-foot T8 IEC	18W (with battery)	120V, 50-60 Hz	0.38A	4 ea. - 20mm metric	Through-feed
1 2261 879 109	eLLK 92 036 /36NIB 1/6-1 M	4-foot T8 IEC	36W (with battery)	240V, 50-60 Hz	0.18A	2 ea. - 20mm metric	No through-feed
1 2261 879 111	eLLK 92 036 /36NIB 2/6-2 M	4-foot T8 IEC	36W (with battery)	240V, 50-60 Hz	0.18A	4 ea. - 20mm metric	Through-feed
1 2261 879 409	eLLK 92 036 /36NIB 1/6-1 M	4-foot T8 IEC	36W (with battery)	120V, 50-60 Hz	0.7A	2 ea. - 20mm metric	No through-feed
1 2261 879 411	eLLK 92 036 /36NIB 2/6-2 M	4-foot T8 IEC	36W (with battery)	120V, 50-60 Hz	0.7A	4 ea. - 20mm metric	Through-feed

*2 hubs provided. May be connected through-feed or tandem. Cable glands ordered separately for 3/4" (remove hubs) or M 25 openings (remove hubs).

Lamp Selection:

NEC LAMP

Type	17W	32W
Phillips	F17T8/TI841	F32T8/TL841
GE	F17T8/SPX41	F32T8/SPX41
Osram/Sylvania	F017/841	F032/841

IEC LAMP

Type	18W	36W
CEAG	3 2475 900 081	3 2475 900 002

Weights:

Watts	Weight
17W and 18W	4.6 Kg. (10 lb.)
17W and 18W (with battery)	10 Kg. (22 lb.)
32W and 36W	6.7 Kg. (14 lb.)
32W and 36W (with battery)	12 Kg. (26 lb.)

Crouse-Hinds
 by **E.T.N**

Accessories:

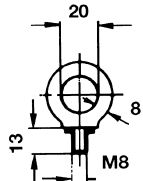

Eyebolt A2

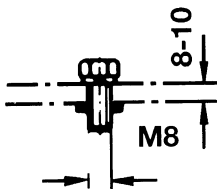

Hexagon Screw S4

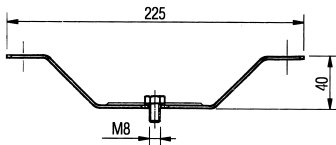

Ceiling Mounting Bracket D92

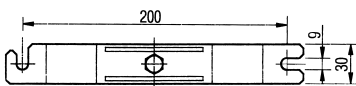

Pipe Clamp

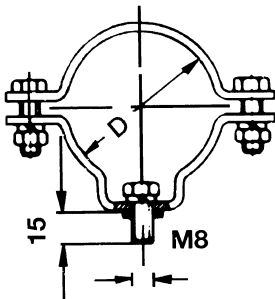

Wall Bracket W27

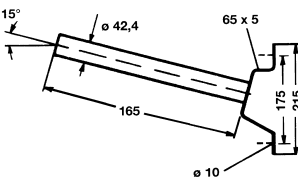

**Dimensions
In Millimeters:**

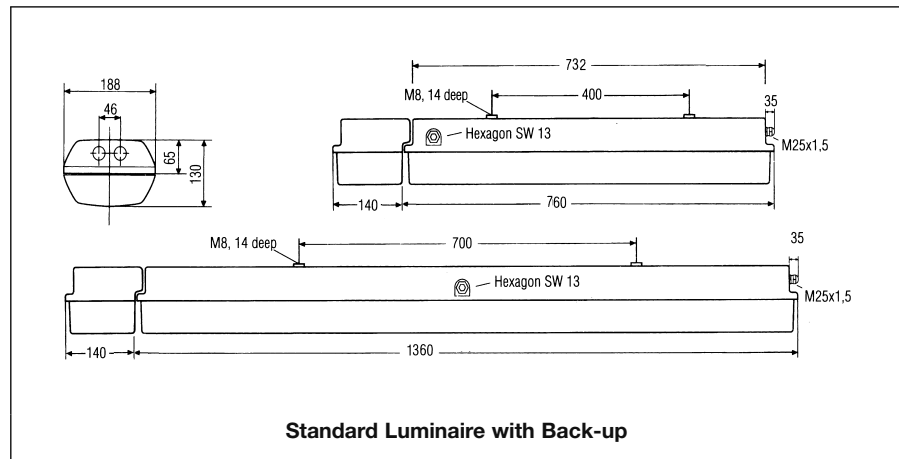

Type	Corrosion Protection	Pipe DIN	Outer Ø D (mm)	Quantity per Luminaire	Cat. #
Eyebolt A2	Galvanized	—	—	2	2 2480 002 000
Hexagon Screw S4	Stainless Steel	—	—	2	2 2480 054 000
Ceiling Mounting Bracket D92	Stainless Steel	—	—	2	2 2480 092 000
Pipe Clamp	R12 Hot Galvanized	1 1/4"	38-42	2	2 2480 462 000
	R14 CrNi	1 1/4"	38-42	2	2 2480 464 000
	R22 Hot Galvanized	1 1/2"	47-51	2	2 2480 472 000
	R32 Hot Galvanized	2"	56-60	2	2 2480 482 000
Hexagon Key SW13 eLLK 92	—	—	—	—	3 2485 000 005
Wall Bracket W27	Hot Galvanized	—	42.4	1	2 2483 027 000



eLLK Series™ Fluorescent Non-metallic Luminaires

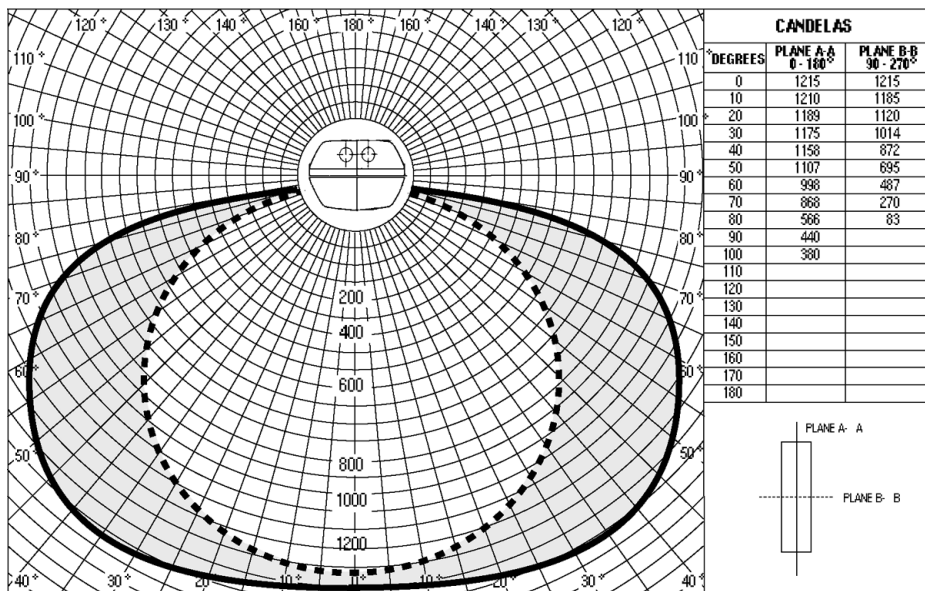

Photometric data developed using two (2) F32T8 3350 lumen lamps.
For the 17W eLLK, use a 0.45 multiplier.

Coefficient of Utilization

Effective Floor Cavity Reflectance 20%

Eff. Ceil.	Wall	Work	Room Cavity Ratio								
			1	2	3	4	5	6	7	8	9
80*	70*	20*	41	49	55	61	65	70	74	77	80
	50*	20*	30	38	44	50	55	62	67	71	75
	30*	20*	23	30	36	43	48	55	61	65	70
	10*	20*	18	25	30	37	42	50	56	61	66
70*	70*	20*	40	47	53	58	62	68	71	74	77
	50*	20*	29	37	42	49	54	60	65	68	72
	30*	20*	22	30	35	42	47	54	59	64	68
	10*	20*	18	24	30	36	42	49	54	59	64
50*	50*	20*	27	35	40	46	50	56	61	64	68
	30*	20*	21	28	34	40	45	51	56	60	64
	10*	20*	17	24	29	35	40	47	52	57	61
30*	50*	20*	26	38	37	43	47	58	57	60	64
	30*	20*	20	27	32	38	43	49	53	57	61
	10*	20*	17	23	28	34	39	45	50	54	58
10*	50*	20*	24	31	35	41	45	50	54	57	60
	30*	20*	20	26	31	36	41	46	51	54	68
	10*	20*	16	22	27	33	37	43	48	52	55
0*	0*	20*	14	20	25	31	35	41	46	49	53

*Percent Reflectance.

5L

nLLK Series Non-metallic Fluorescent Luminaires

Cl. I, Div. 2, Groups A, B, C, D
Cl. I, Zone 2, AEx nA II
Cl. II, Div. 2, Groups F, G
Enclosure Type 4X

Wet Locations
UL and cUL Listed
ATEX Certified

5L

Eaton's Crouse-Hinds SpecOne™ nLLK Series Fluorescent Luminaire is an ideal source of general illumination indoors or out, in ordinary or hazardous environments. Its heavy duty, non-metallic construction stands up to tough physical and environmental demands, making it an excellent choice where dust, dirt, gas, vapor, smoke, fumes, moisture, corrosive and wet conditions are present. As with all SpecOne products, the nLLK Luminaire meets the standards and codes of regulating agencies throughout the world, which simplifies product specifying for multi-national users.



Applications:

nLLK Series Luminaires are used:

In indoor or outdoor, ordinary or hazardous areas

Where a heavy duty, non-metallic luminaire is required to hold up to tough physical and environmental demands including corrosives, water, dust, and extreme temperatures

- Manufacturing plants
- Heavy industrial facilities
- Industrial process facilities
- Refineries
- Chemical
- Petrochemical
- Pharmaceutical
- Wastewater and sewage treatment plants

In areas where low mounting height, immediate full illumination, and the even light distribution associated with a line type light source are required

- Loading docks
- Tunnels
- Stairways

Where wet location or Type 4X protection is required

- Dock areas
- Production platforms

In hose down areas where cleanliness and sanitation are prime factors

- Dairies
- Canneries
- Food processing plants
- Bottling plants
- Laboratories

Certifications and Compliances:

- NEC:
 - Class I, Division 2, Groups A, B, C, D
 - Class I, Zone 2, AEx nA II
 - Class II, Division 2, Groups F, G
 - Wet Locations
 - UL Listed
- CEC:
 - Class I, Zone 2, Ex nA II
 - Class I, Division 2, Groups A, B, C, D
 - Class II, Division 1, Groups E, F, G
 - cUL Listed (certified by UL)
- Enclosure:
 - Type 4X
 - IP65
- UL Standards:
 - 844 Hazardous (Zones Classified) Locations
 - 1598 Luminaires
- CSA Standards:
 - C22.2 No. 9
 - CAN/CSA-E79-15

ATEX

- ATEX Directive 94/9/EC
 - Ex II 3G Ex nA de IIC T4
 - Ex II 3G Ex nA de mb IIC T4
 - Ex II 3D Ex tD A22 IP66 T80°C
- Type of Protection
 - BVS 09 ATEX E147
- EC-Type Examination Certificate

Standard Materials:

- One-piece housing – fiberglass-reinforced polyester
- Lens – polycarbonate
- Gasket – silicone

Standard Finishes:

- Fiberglass housing – natural (white)
- Lens – natural (clear)

Ratings (Electrical/Size):

Sources/Wattages

- Two (2) 17W or two (2) 32W linear fluorescent

Voltages

- 120-277 V, 50-60 Hz
- 347 V, 60 Hz — consult factory

Hub Size

- Four 25 mm entries, two on each end, three plugged
- Two Myers STM2 25 mm to 3/4" NPT adapter hubs provided standard for through-feed or tandem wiring

5L

5L

nLLK Series Non-metallic Fluorescent Luminaires

Cl. I, Div. 2, Groups A, B, C, D
 Cl. I, Zone 2, AEx nA II
 Cl. II, Div. 2, Groups F, G
 Enclosure Type 4X

Wet Locations
 UL and cUL Listed

IP65, Type 4X heavy duty construction

- Non-metallic body, gasketed lens and unique labyrinth lens locking system
- Dust-tight, water-tight and moisture-tight
- Corrosion and impact-resistant
- Ideal for outdoor applications

Electronic ballast

- Lower ambient temperatures suitability to -18°C
- High-power factor ballast (+90%) allows for more luminaires per circuit

Standard T8 bi-pin lamps

- Most common lamp used; energy-efficient and cost-effective

Removable lens

- Hinged on both sides for easy installation and maintenance

Easy wiring and installation

- Four 25 mm entries; two Myers™ 3/4" NPT adapter hubs supplied standard
- Suitable for through-feed or tandem applications
- Extra large wire well eliminates need for separate junction boxes

Worldwide suitability

- NEC/CEC: Class I, Zone 2 and Division 2 areas
- IEC/CENELEC certified luminaires available (consult factory)



Ordering Information:

Cat. #	Description	Length & Lamp Type	Lamp Watt - 2 Lamp	Rated Voltage	Rated Current	Conduit Hub Size	Comments
NEC (NOT ATEX CERTIFIED)							
1 3465 217 021	nLLK 98 2217 /UNV	2-foot T8	17W	120V-277V, 60 Hz	0.16A	2 ea. - 3/4" Myers hub	Through-feed
1 3465 217 347	nLLK 98 2217 /347 2/5 2 NPT 3/4" M UL	2-foot T8	17W	347V, 60 Hz	0.16A	2 ea. - 3/4" Myers hub	Through-feed
1 3465 232 021	nLLK 98 4232 /UNV	4-foot T8	32W	120V-277V, 60 Hz	0.31A	2 ea. - 3/4" Myers hub	Through-feed
1 3465 232 347	nLLK 98 4232 /347 2/5 2 NPT 3/4" M UL	4-foot T8	32W	347V, 60 Hz	0.31A	2 ea. - 3/4" Myers hub	Through-feed
IEC (ATEX CERTIFIED)							
1 3465 218 011	nLLK 08 018/18	2-foot T8	18W	220V-240V, 50-60 Hz	0.16A	2 ea. - 25mm metric	Through-feed
1 3465 218 021	nLLK 08 018/18	2-foot T8	18W	220V-240V, 50-60 Hz	0.16A	2 ea. - 20mm metric	Through-feed
1 3465 236 011	nLLK 08 036/36	4-foot T8	36W	220V-240V, 50-60 Hz	0.31A	2 ea. - 25mm metric	Through-feed
1 3465 236 021	nLLK 08 036/36	4-foot T8	36W	220V-240V, 50-60 Hz	0.31A	2 ea. - 20mm metric	Through-feed

Accessories:

Description	Cat. #
SW13 hexagon key (for maintenance and lamp replacement)	3 2485 000 005
Myers™ 25mm to 3/4" NPT adapter hub	STM 2

Type	Corrosion Protection	Pipe DIN	Outer Ø D (mm)	Quantity per Luminaire	Cat. #
Eyebolt A2	Galvanized	—	—	2	2 2480 002 000
Hexagon Screw S4	Stainless Steel	—	—	2	2 2480 054 000
Ceiling Mounting Bracket D92	Stainless Steel	—	—	2	2 2480 092 000
Pipe Clamp	R12 Hot Galvanized	1 1/4"	38-42	2	2 2480 462 000
	R14 CrNi	1 1/4"	38-42	2	2 2480 464 000
	R22 Hot Galvanized	1 1/2"	47-51	2	2 2480 472 000
	R32 Hot Galvanized	2"	56-60	2	2 2480 482 000
Hexagon Key SW13 eLLK 92	—	—	—	—	3 2485 000 005
Wall Bracket W27	Hot Galvanized	—	42.4	1	2 2483 027 000

nLLK Series Non-metallic Fluorescent Luminaires

Cl. I, Div. 2, Groups A, B, C, D
 Cl. I, Zone 2, AEx nA II
 Cl. II, Div. 2, Groups F, G
 Enclosure Type 4X

Wet Locations
 UL and cUL Listed

5L

Photometric Data:

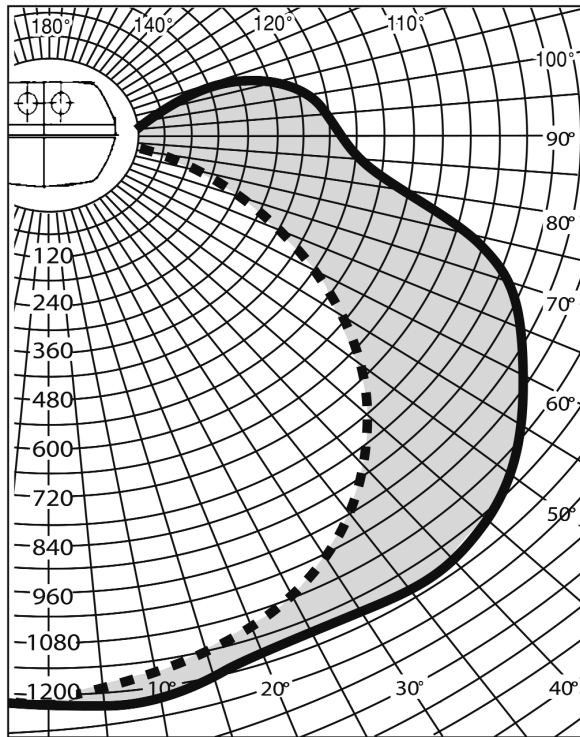

CANDELAS		
DEGREES	PLANE A-A 0 - 180°	PLANE B-B 90 - 270°
0	1215	1215
10	1210	1185
20	1189	1120
30	1175	1014
40	1158	872
50	1107	695
60	998	487
70	868	270
80	566	83
90	440	
100	380	
110		
120		
130		
140		
150		
160		
170		
180		

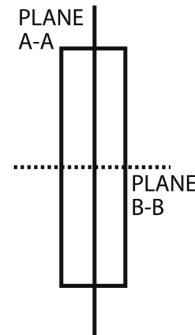

Temperature Performance:

Minimum Starting Temperature: -18°C

Watts	Ambient	Class I, Div. 2 (Class I, Zone 2)	Class II, Div. 1 (CEC) Class II, Div. 2 (NEC)	Supply Wire Temp. °C
Two 17W T8 lamps	40°C	T4	T6	60
Two 32W T8 lamps	40°C	T4	T6	60

Maintenance and Relamping:

(eLLK Series Div. 1/Zone 1 luminaire is shown. Maintenance procedures are the same for the nLLK.)

1. **One quarter turn** with the SW13 hexagon key or a 5/16" (M8) Allen hex head wrench releases multiple locking points.
2. **Lamps can be stored** in open lens, freeing up hands for easy relamping.
3. **Replace the bi-pin lamp lock** with one quarter turn of the wrench for an IP65, Type 4X seal.



Dimensions (mm) and Weight:

Weight: 8.8 lbs. (4.0 kg.)—18W 13.2 lbs. (6.0 kg.)—36W

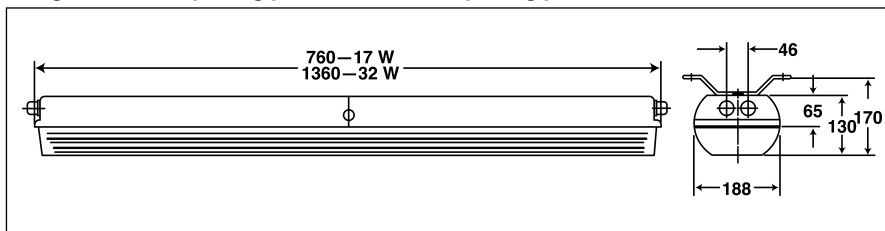

Accessories:

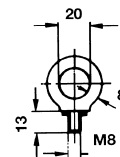

Eyebolt A2

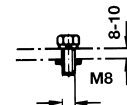

Hexagon Screw S4

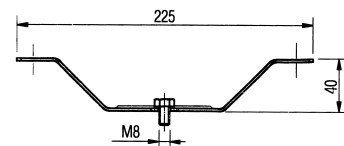

Ceiling Mounting Bracket D92

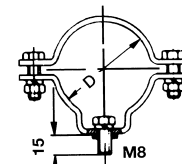

Pipe Clamp

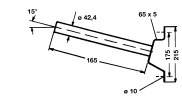

Wall Bracket W27

5L **FVN Series Fluorescent Luminaires**

Cl. I, Div. 2, Groups A, B, C, D
Cl. I, Zone 2, Group IIC
Cl. II, Div. 1, Groups F, G
Cl. III & Simultaneous Presence

Wet Locations
NEMA 3, 3R

Applications:

FVN Luminaires are ideal for use:

- In areas made hazardous by the abnormal conditions resulting in the presence of flammable vapors or gases and combustible dusts as defined by the National Electrical Code®
- Where broken lamps would damage machinery or processes, or harm people working in the area
- In areas where stringent sanitation requirements exist

Features:

- One-piece seamless sheet steel housing with welded end caps keeps dirt, dust and moisture away from ballast and lamps; easy to clean
- A silicone rubber gasket provides a dust-tight seal between the lens/frame assembly and housing
- Lens/frame assembly is hinged and wireway cover is held by safety chain for ease of lamp replacement and maintenance
- Polyester powder coat finish provides high reflectance and corrosion resistance for long life and dependable service
- Two 1/2" NPT pendant hubs and two 1/2" NPT thru-feed end hubs are standard
- Electronic ballast is standard on 32 and 54 watt luminaires (UNV only)

FVN Fluorescent Luminaires with T5 HO lamps offer:

- High lumen output per watt – provides energy savings versus other higher wattage fluorescent luminaires with similar lumen output
- Longer lamp life and good lumen maintenance – reduced maintenance and lamp replacement costs

Certifications and Compliances:

- NEC and CEC:
 - Class I, Division 2, Groups A, B, C, D
 - Class I, Zone 2, Group IIC
 - Class II, Division 1, Groups F, G
 - Class III
 - Simultaneous Presence (Cl. I and Cl. II)
- UL Standards:
 - 844 Hazardous (Classified) Areas
 - 1598 Luminaires
- CSA Standards:
 - C22.2 No. 137



Standard Materials:

- Luminaire housing – 20-gauge seamless sheet steel
- Lens/frame assembly – stainless steel
- Glass – 3/16" tempered
- Suspension flanges – seamless sheet steel
- Gaskets – silicone
- Lampholders – white thermoset plastic
- Clamps – stainless steel

Standard Finishes:

- Reflector housings – corrosion-resistant white polyester powder coat
- Lens/frame – natural

Dimensions

In Inches:

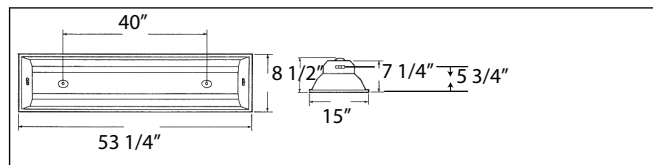

5L

Ordering Information (Lamps not supplied):

Lamp Watts	Line Voltage/Hertz	Lamp Type	Hub Size	2-Lamp Cat. #	3-Lamp Cat. #
32	120-277/50-60	T8	1/2 NPT	FVN4232TG/UNV	FVN4332TG/UNV
32	347 / 60	T8	1/2 NPT	FVN4232TG/347	FVN4332TG/347
40	120 / 50-60	T12	1/2 NPT	FVN4240TG/120	FVN4340TG/120
40	277 / 60	T12	1/2 NPT	FVN4240TG/277	FVN4340TG/277
40	347 / 60	T12	1/2 NPT	FVN4240TG/347	FVN4340TG/347
60	120 / 60	T12HO	1/2 NPT	FVN4260TG/120	—
60	277 / 60	T12HO	1/2 NPT	FVN4260TG/277	—
60	347 / 60	T12HO	1/2 NPT	FVN4260TG/347	—
60	220 / 50	T12HO	1/2 NPT	FVN4260TG/200 50	—
FVN Fluorescent Luminaires with T5 HO Lamps (Lamps not supplied)					
54	120-277/50-60	T5HO	1/2 NPT	FVN4254TG/UNV	—
54	347 / 60	T5HO	1/2 NPT	FVN4254TG/347	—

FN Series Fluorescent Luminaires

Cl. I, Div. 2, Groups A, B, C, D
Cl. I, Zone 2, Group IIC
Cl. II, Div. 1, Groups F, G
Cl. III & Simultaneous Presence

Wet Locations
NEMA 3, 3R

5L

Options:

The following special options are available from the factory by adding suffix to luminaire Cat. No.:

Description

- Low temperature electromagnetic ballast, 40W rated 0°F (-18°C), 60W rated -20°F (-29°C).....
- 45° angle brackets (field installed).....
- Adjustable angle brackets (field installed).....
- Angle bars for chain suspension (field installed).....
- Individually fused ballast (internal).....
- Emergency lighting battery unit (Class I, Division 2 only). Also available for use with T5 lamps. Supplied with charging indicator light and instructions for use with a remote push-to-test station.....

*If push-to-test operator installed in the luminaire is required, consult factory.

Suffix
BY
AG
KH
CX
FB
S799*

Temperature Performance Data: (Based on 40°C ambient)

Lamp	Cl. I, Div. 2 & Zone 2		Class II		Simultaneous Presence		Supply Wire
	2-Lamp	3-Lamp	2-Lamp	3-Lamp	2-Lamp	3-Lamp	
32W	T5	T5	T6	T6	T4	T4	60°C
40W	T5	T5	T6	T6	T4	T4	60°C
54W	T3C	—	T6	—	T3C/T6	—	75°C
60W	T4	—	T6	—	T4	—	90°C

Photometric Data:

Luminaire with two 54W High Output T5 Linear Fluorescent Lamps
FN4254

Luminaire with two 54W High Output T5 Linear Fluorescent Lamps
FN4254

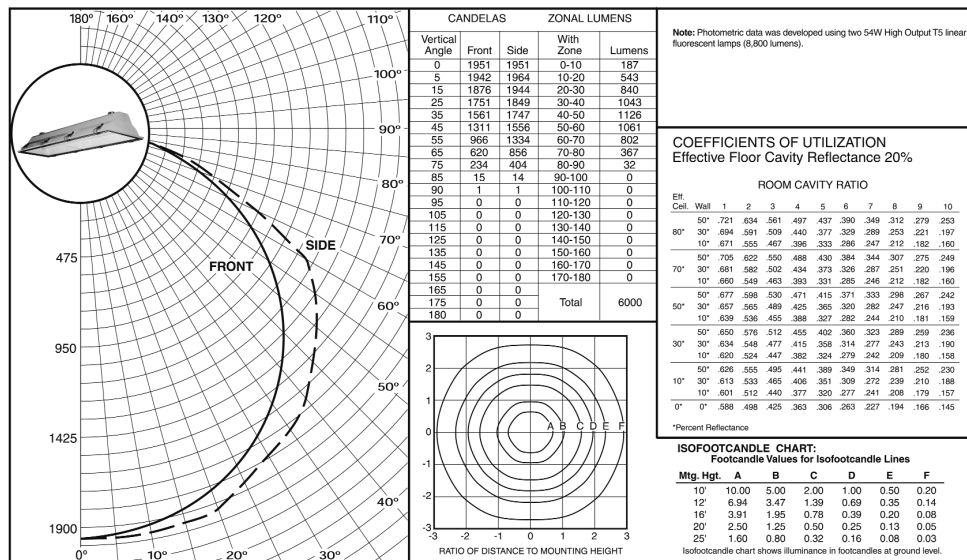

FN Series photometric files for use with our Luxicon® Lighting Layout Software are available from our website.

5L **FN Series** Fluorescent Luminaires

Photometric Data

Luminaire: FVN with 2-40W lamps (tempered lens)

Lamp:	2-40/T-12			
Zonal Degrees:	0-30	0-40	0-60	0-90
Zonal Lumens:	1182	1971	3555	4284
Total Bare Lamp Lumens:	6300			

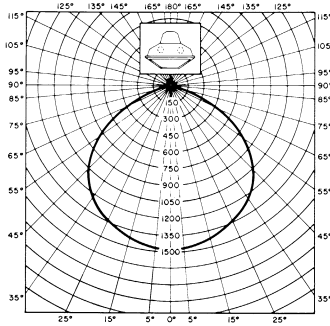

All data provided is for 2-lamp 40W RS cool white luminaires with tempered glass. Use 1.37 multiplier for 2-lamp 60W luminaires with tempered glass. Use .92 multiplier for 2-lamp 32W luminaires with tempered glass.

Luminaire: FVN with 3-40W lamps (tempered lens)

Lamp:	3-40/T-12			
Zonal Degrees:	0-30	0-40	0-60	0-90
Zonal Lumens:	1695	2834	5099	6079
Total Bare Lamp Lumens:	9450			

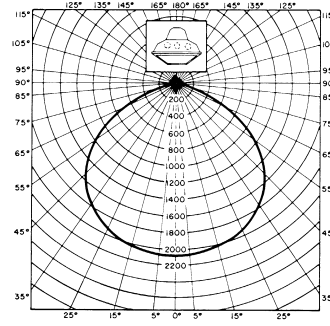

All data provided is for 2-lamp 40W RS cool white luminaires with tempered glass. Use 1.37 multiplier for 2-lamp 60W luminaires with tempered glass. Use .92 multiplier for 2-lamp 32W luminaires with tempered glass.

Coefficient of Utilization

Effective Floor Cavity Reflectance 20%

% Reflectance Eff. Ceil.	% Reflectance Wall	Room Cavity Ratio				
		1	2	3	4	5
80	50	.721	.643	.575	.513	.461
	30	.695	.603	.527	.459	.404
	10	.673	.569	.489	.418	.362
70	50	.706	.631	.566	.505	.452
	30	.683	.594	.520	.455	.399
	10	.661	.564	.485	.415	.359
50	50	.677	.607	.547	.488	.439
	30	.657	.577	.508	.444	.392
	10	.641	.549	.476	.410	.357
30	50	.650	.586	.528	.473	.426
	30	.636	.561	.496	.435	.384
	10	.621	.538	.468	.405	.353
10	50	.627	.568	.512	.459	.414
	30	.614	.544	.484	.426	.378
	10	.602	.526	.460	.399	.349
0	0	.589	.512	.447	.385	.336
% Reflectance Eff. Ceil.	% Reflectance Wall	Room Cavity Ratio				
		6	7	8	9	10
80	50	.416	.375	.338	.309	.269
	30	.359	.319	.283	.254	.215
	10	.319	.281	.244	.217	.180
70	50	.409	.370	.333	.305	.265
	30	.356	.315	.281	.252	.215
	10	.316	.278	.244	.217	.180
50	50	.397	.359	.324	.297	.259
	30	.350	.309	.277	.249	.211
	10	.314	.276	.242	.215	.179
30	50	.386	.348	.316	.289	.253
	30	.344	.306	.272	.244	.208
	10	.311	.273	.240	.214	.177
10	50	.376	.341	.308	.282	.247
	30	.338	.301	.268	.242	.205
	10	.308	.271	.239	.212	.175
0	0	.295	.258	.226	.200	.164

Coefficient of Utilization

Effective Floor Cavity Reflectance 20%

% Reflectance Eff. Ceil.	% Reflectance Wall	Room Cavity Ratio				
		1	2	3	4	5
80	50	.682	.610	.546	.488	.439
	30	.658	.572	.501	.438	.385
	10	.637	.540	.466	.399	.346
70	50	.668	.599	.538	.480	.430
	30	.646	.563	.495	.433	.381
	10	.625	.535	.462	.396	.343
50	50	.640	.576	.520	.464	.418
	30	.622	.547	.484	.423	.374
	10	.606	.521	.453	.391	.341
30	50	.615	.556	.502	.450	.406
	30	.601	.532	.472	.415	.367
	10	.587	.511	.446	.386	.337
10	50	.594	.537	.487	.437	.394
	30	.581	.517	.461	.406	.361
	10	.570	.499	.439	.381	.333
0	0	.557	.487	.426	.368	.321
% Reflectance Eff. Ceil.	% Reflectance Wall	Room Cavity Ratio				
		6	7	8	9	10
80	50	.396	.357	.322	.294	.256
	30	.343	.304	.270	.242	.205
	10	.305	.268	.234	.207	.172
70	50	.390	.352	.317	.290	.252
	30	.340	.301	.268	.240	.205
	10	.302	.266	.233	.207	.172
50	50	.378	.342	.309	.282	.247
	30	.334	.295	.264	.237	.201
	10	.300	.264	.231	.206	.171
30	50	.368	.332	.301	.276	.241
	30	.328	.292	.259	.233	.199
	10	.298	.261	.230	.204	.169
10	50	.358	.325	.294	.269	.235
	30	.322	.288	.256	.231	.196
	10	.294	.259	.228	.202	.168
0	0	.283	.247	.217	.192	.157

5L

eLLB20 Series

Recessed Mount Fluorescent Luminaires

Cl. I, Div. 2, Groups A, B, C, D
Cl. I, Zone 1, Group IIC
ATEX Certified

Cl. II, Div. 2, Groups F, G
Cl. II, Div. 1, Groups E, F, G (Canada)
Wet Locations
Enclosure Type 4X and IP66

5L

Applications:

eLLB Series Luminaires are used:

- For flush or surface ceiling mounting
- In clean room areas where it is important to have smooth, flush surfaces
- Where extreme cleanliness is required as in pharmaceutical, chemical, and electronics manufacturing facilities, as well as in paint shops and spray booths
- For tough environmental conditions involving corrosives, water, dust, and extreme temperatures
- In areas that require lamps to reach full illumination immediately
- Indoor and outdoor ordinary or hazardous areas
- For wet locations and areas with hose down / wash down requirements

Features and Benefits:

- One-piece welded housing with fitted cover frame; the cover frame is an integral part of the housing to seal out dust and moisture
- Adjustable mounting clamps:
Permanently attached and adjustable through the cover frame for easy installation
Allow recess mounting in ceilings from 25mm to 100mm (1" to 4" approx.) thick for maximum mounting flexibility
- Support lugs (M8 x .6) to secure the luminaire to ceiling structural support members for safety
- Frameless tempered glass lens:
6mm (1/4") thick for added safety
Interior hinge for maximum dust shedding
Fitted with captive screws for ease of lamp replacement and maintenance
- Isolating switch turns off power to the ballast and lamps when the lens is opened for added safety
- 4 entries (2 on each end) supplied with (2) 3/4" NPT adapter hubs and extra large wire well for feed-through and tandem applications without the need for separate junction boxes
- Electronic ballast:
High power factor (95%) for energy efficiency, more luminaires per circuit and supply voltage flexibility
Features 2 channel circuitry for safety - if one lamp fails, the 2nd lamp remains in operation
- Uses T8 linear fluorescent lamps for high efficiency and reduced operating costs
- 5 wire terminal block and through wiring are standard for quick and easy balancing of lighting loads on 3-phase systems

Certifications and Compliances:

- NEC:
Class I, Division 2, Groups A, B, C, D
Class I, Zone 1, AEx ed IIC
Class II, Division 2, Groups F, G
UL Listed
- CEC:
Class I, Division 2, Groups A, B, C, D
Class I, Zone 1, Ex eds IIC
Class II, Division 1, Groups E, F, G
cUL Listed
- Enclosure:
Type 4X
IP66
- UL Standards:
844 Hazardous (Classified) Locations
1598 Luminaires
- CSA Standards:
C22.2 No. 9
CAN/CSA-E60079-0:02
CAN/CSA-E60079-1:02
CAN/CSA-E60079-7
CAN/CSA-E61241-1-1:02

ATEX

- ATEX Directive
94/9/EC
Ex II 2 G
- Type of Protection
Ex ed IIC T4
Ex ed ib IIC T4
(CG-variant)
- EC-Type Examination Certificate
DMT 02 ATEX E 069

Standard Materials:

- One-piece welded housing and cover frame - sheet steel or stainless steel
- Lens - 6mm (1/4") thick tempered glass
- Gaskets - silicone
- External hardware - stainless steel

Standard Finishes:

- Sheet steel - white epoxy coat
- Lens - clear
- Stainless steel - natural

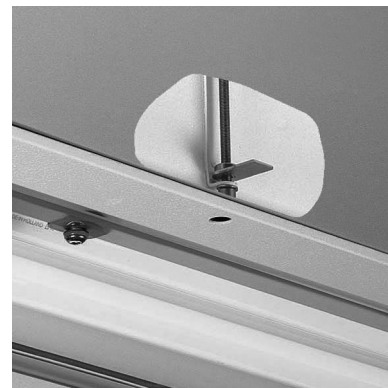
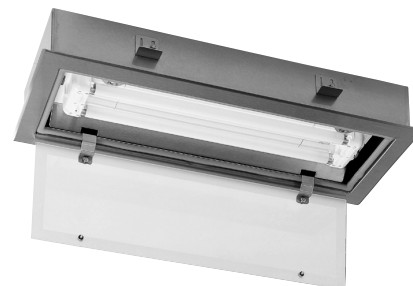

Adjustable Mounting Clamps



Hinged Glass Lens

5L

5L

eLLB20 Series

Recessed Mount Fluorescent Luminaires

Cl. I, Div. 2, Groups A, B, C, D
Cl. I, Zone 1, Group IIC
ATEX Certified

Cl. II, Div. 2, Groups F, G
Cl. II, Div. 1, Groups E, F, G (Canada)
Wet Locations
Enclosure Type 4X and IP66

Ratings (Electrical / Size):

Sources/Wattages

- Two 32W or 17W T8 Linear Fluorescent

Voltages

- 120-240V, 50-60 Hz
- 110-230VDC

Hub Size

- Four 25mm entries, 2 on each end, 3 plugged
- Two 3/4" NPT adapter hubs provided standard, for feed-through or tandem wiring

Terminals

- 5 wire terminal block, one on each end (L1, L2, L3, N, Ground)
- Two 6mm² (#10 AWG) maximum per terminal

Temperature Performance Data:

Minimum Starting Temperature: -20°C

Watts	Ambient Temp.	Cl. I, Div. 2 Cl. I, Zone 1 & 2	Class II	Supply Wire Temp.
Two 17W T8 lamps	50°C	T4	T6	60°C
Two 32W T8 lamps	50°C	T4	T6	60°C

Accessories:

Description	Cat. #
• 3/4" NPT adapter hub	STM 2
<i>Mounting Accessories:</i>	
• Eye Bolt for Support Lugs	2 2480 002 000
• Hexagon Screw for Support Lugs	2 2480 054 000

Ordering Information:

Hub Size	Wattage/Lamp	Voltage/Hz	Operating Current	Cat. #	
				Epoxy Coated Steel Enclosure	Stainless Steel Enclosure
3/4" NPT	Two 17 Watt T8 Rapid Start	120-240V, 50-60 Hz 110-230 VDC	.18A	ELLB202217/U240	ELLB202217SS/U240
3/4" NPT	Two 32 Watt T8 Rapid Start	120-240V, 50-60 Hz 110-230 VDC	.34A	ELLB204232/U240	ELLB204232SS/U240

IEC / GENELEC certified luminaires are available. Consult factory.

Dimensions (Inches) and Weights:

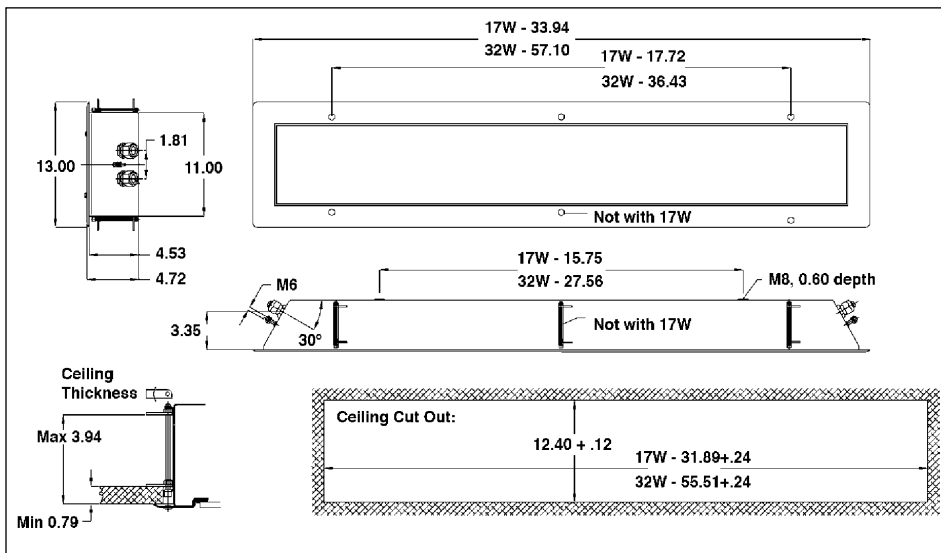

Item	Weight
eLLB20 2217	33 lbs.
eLLB20 4232	48 lbs.

5L

Recessed Mount
Fluorescent Luminaires

Photometric Data:

LUMINAIRE: eLLB20 2217 LAMP: TWO F17T8 LINEAR FLUORESCENT

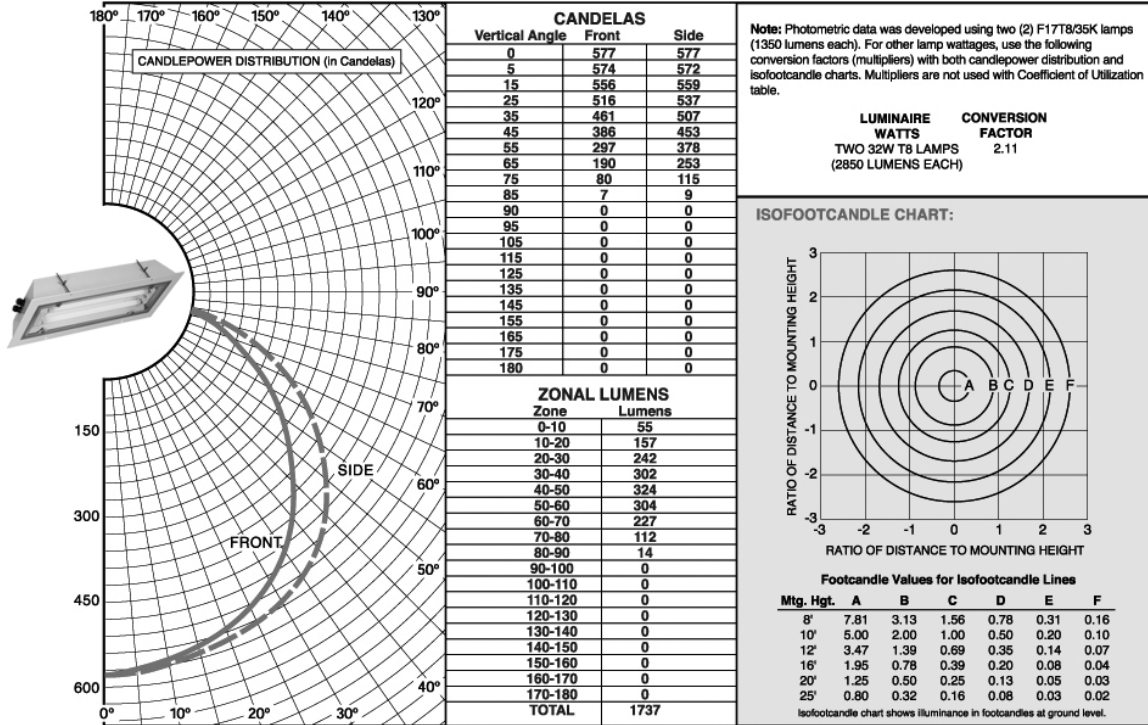

Coefficients Of Utilization – Zonal Cavity Method
Effective Floor Cavity Reflectance 20%

Eff. Ceil.	Wall	Room Cavity Ratio									
		1	2	3	4	5	6	7	8	9	10
80*	50*	0.679	0.597	0.528	0.468	0.412	0.368	0.329	0.294	0.263	0.239
	30*	0.654	0.556	0.478	0.414	0.355	0.310	0.272	0.239	0.209	0.186
	10*	0.631	0.522	0.439	0.372	0.313	0.269	0.233	0.200	0.172	0.151
70*	50*	0.664	0.585	0.518	0.459	0.405	0.362	0.324	0.290	0.259	0.235
	30*	0.641	0.547	0.472	0.409	0.351	0.307	0.270	0.237	0.207	0.185
	10*	0.621	0.516	0.435	0.369	0.311	0.268	0.232	0.200	0.172	0.151
50*	50*	0.637	0.562	0.499	0.443	0.391	0.350	0.314	0.281	0.252	0.229
	30*	0.618	0.531	0.460	0.399	0.344	0.302	0.265	0.233	0.204	0.182
	10*	0.601	0.504	0.427	0.364	0.308	0.266	0.230	0.198	0.171	0.150
30*	50*	0.612	0.542	0.482	0.429	0.379	0.339	0.305	0.273	0.245	0.223
	30*	0.597	0.515	0.448	0.390	0.337	0.296	0.261	0.229	0.201	0.180
	10*	0.583	0.492	0.420	0.360	0.304	0.263	0.228	0.197	0.170	0.149
10*	50*	0.589	0.522	0.465	0.415	0.367	0.329	0.296	0.265	0.238	0.217
	30*	0.577	0.501	0.437	0.382	0.330	0.291	0.257	0.226	0.198	0.177
	10*	0.566	0.481	0.413	0.355	0.301	0.261	0.227	0.196	0.169	0.149
0*	0*	0.553	0.468	0.400	0.341	0.288	0.248	0.214	0.183	0.156	0.137

*Percent Reflectance.

5L EVF Series Fluorescent Luminaires

Cl. I, Div. 1, Groups C, D
Cl. I, Zone 1, Group IIB
Cl. II, Div. 1, Groups E, F, G
Cl. III, Simultaneous Presence

Paint Spray (Suffix S718)
Wet Locations (Suffix S718)
3, 3R, IP54 (Suffix S718)

Applications:

- EVF Luminaires are used in areas where hazardous fumes, gases, or dusts are present
- EVF Luminaires with S718 option are designed specifically for use inside paint spray booths where hazardous fumes, gases, and paint residue are present; this includes powder paint process areas
- EVF Luminaires with S718 option are also suitable for use in wet locations

Features:

All EVF Luminaires:

- Provide cool, even light with natural color rendition
- Reduce relamping schedule (long lamp life)
- Continuous and uniform illumination made possible by mounting end to end (no space needed between luminaires for relamping)
- No special tools required for relamping; threaded lamp tube cover provides quick and easy access for relamping
- Threaded joints on lamp tube and wiring chamber covers permit easy access for lower maintenance costs
- Reflectors can be removed or replaced with only a screwdriver
- Easy to install; factory-sealed and wired luminaire facilitates installation
- Standard electronic ballast for 32 watt and 40 watt rapid start luminaires
- Standard energy-efficient ballast for 40 watt slimline, 60 watt and 110 watt luminaires
- Low temperature ballast is supplied as standard on 32 watt T8 (0°F), 40 watt slimline (0°F), 60 watt and 110 watt luminaires (-20°F)
- All exposed hardware is stainless steel for maximum protection against corrosion, and for longer luminaire life
- Copper-free aluminum construction throughout means lighter luminaire weight, easier installation, and excellent corrosion resistance
- All exterior materials are non-sparking
- Type P ballasts furnished in compliance with NEC
- Heavy-duty glass lamp tubes provide maximum strength and impact resistance to protect lamps

EVF Luminaires with S718 Option:

- All joints sealed
- Inside paint booth mounting capabilities provide greater flexibility in luminaire placement, avoids necessity of complicated design and installation work, and improves task lighting control
- Smooth, simple design makes it easy to remove any accumulated deposits of paint residue

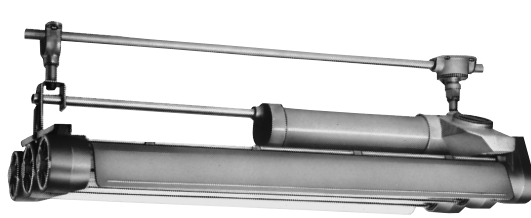

3-lamp



2-lamp with angle reflector

Ordering Information:

Furnished For Use with	Hub Size	Line Volts 60 Hz	1-Lamp Cat. #	2-Lamp Cat. #	3-Lamp Cat. #	4-Lamp Cat. #
32 watt, T-8 medium Bi-pin 265MA lamps	3/4"	120-277	EVF21029/UNV	EVF22029/UNV	EVF23029/UNV	EVF24029/UNV
	3/4"	347	EVF21029/347	EVF22029/347	EVF23029/347	EVF24029/347
40 watt, T-12 medium Bi-pin rapid start 430MA lamps†	3/4"	110-125	EVF21082	EVF22082	EVF23082	EVF24082
	3/4"	277	EVF21087	EVF22087	EVF23087	EVF24087
	3/4"	347	EVF21089/347	EVF22089/347	EVF23089/347	EVF24089/347
40 watt, T-12 single pin, slimline 425MA lamps	3/4"	110-125	EVF21032	EVF22032	EVF23032	EVF24032
	3/4"	277	EVF21037	EVF22037	EVF23037	EVF24037
	3/4"	347	EVF21039/347	EVF22039/347	EVF23039/347	EVF24039/347
60 watt, T-12 recessed contact, 800MA lamps†	3/4"	110-125	EVF21062	EVF22062	EVF23062	EVF24062
	3/4"	277	EVF21067	EVF22067	EVF23067	EVF24067
	3/4"	347	EVF21069/347	EVF22069/347	EVF23069/347	EVF24069/347
110 watt, T-12 recessed contact, 1500MA lamps†	3/4"	110-125	EVF21072	EVF22072	EVF23072	EVF24072
	3/4"	277	EVF21077	EVF22077	EVF23077	EVF24077
	3/4"	347	EVF21079/347	EVF22079/347	EVF23079/347	EVF24079/347

†50 Hz not available.

Certifications and Compliances:

- NEC and CEC:
Class I, Division 1, Groups C, D
Class I, Zone 1, Group IIB
Class II, Groups E, F, G
Class III
Simultaneous Presence (Cl. I and Cl. II)
Paint Spray (S718)
- UL Standards:
844 Hazardous (Classified) Locations
1598 Luminaires
- CSA Standards:
C22.2 No. 137

Standard Materials:

- Copper-free aluminum except sheet aluminum reflectors

Standard Finishes:

- Natural except reflectors
- Reflectors - white epoxy powder coat

Options:

Description	Suffix
• For suitability for wet locations and locations having deposits of readily combustible paint residue	S718
• Corro-free™ epoxy powder coat	S752
• With 45° angle reflectors in lieu of straight down reflectors	S369
• Fused (not suitable for marine applications)	S658
• Furnished with lamps	S714
• Low temperature electromagnetic ballast for 40 watt T12 rapid start luminaires rated for 0°F	BY

Mounting Accessories:

Various hazardous area fittings are used to mount EVF Luminaires. The fittings shown on next page support the unwired (relamping) end. For the wired (ballast) end any of the luminaire hangers for hazardous locations (listed in Section 7L) can be used. CPS conduit outlet bodies with hub covers (listed in Section 3F) are also suitable.

Size Ranges:

- 1, 2, 3, and 4-lamp

Electrical Rating Ranges:

- 32 to 110 watts

Temperature Performance Data: (Based on 40°C Ambient)

Class I/Class II/Zone 1

Lamp Type	1-Lamp	2-Lamp	3-Lamp	4-Lamp	Supply Wire
32/40W	T5	T5	T5	T5	75°C
60W	T5	T5	T5	T5	75°C
110W	T4	T4	T4	T4	90°C

Crouse-Hinds
by **E.T.O.N**

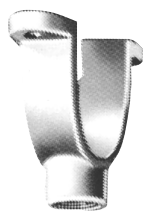

**Ceiling Saddle
Conduit Support**

Description	Size (In.)	Cat. #
Ceiling Saddle for Conduit Support	3/4	EVF20

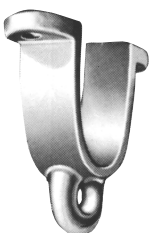

**Ceiling Saddle
Support Hook**

Description	Cat. #
Ceiling Saddle for Support Hook	EVF021



**Support Hook
for Conduit**

Description	Size (In.)	Cat. #
Support Hook for Conduit	3/4	EVF21

Relamping Information

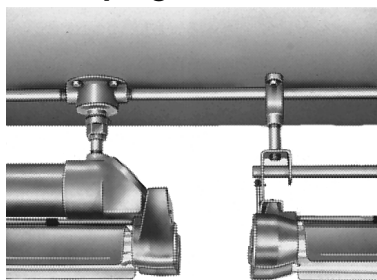

Adjacent ends of two fixtures suspended in line close together

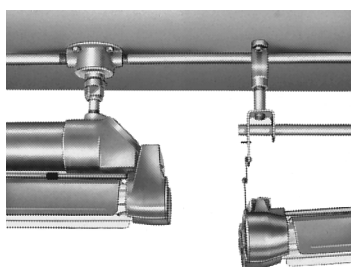

End of one fixture lowered for relamping

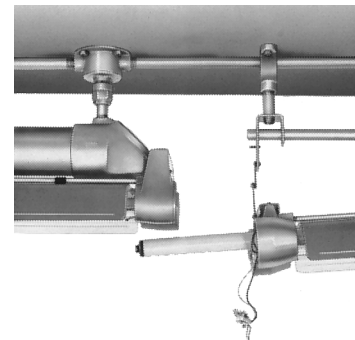

One cover removed and lamp partly withdrawn

Where fixtures abut, space for relamping is obtained by lowering one end of the tube assembly as shown. Without tools, the lamp receptacle and mounting plate assemblies can be removed and the lamp withdrawn. In inserting, the reverse procedure is followed.

Dimensions:

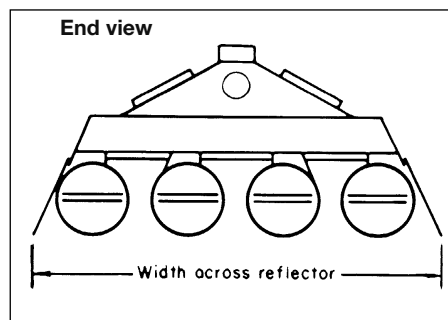
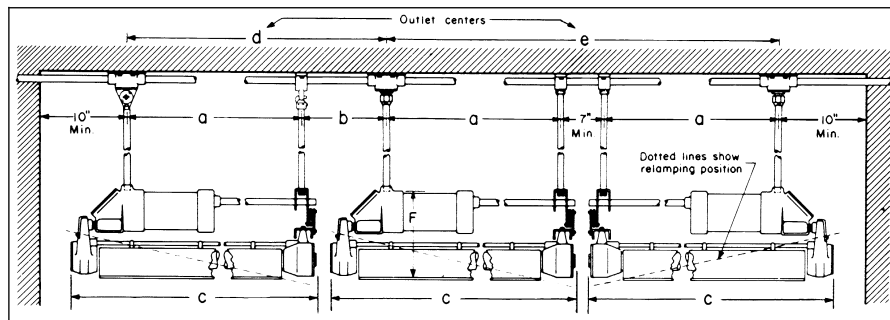

Fixture Type	No. Lamps	a	b	c	d	e	f
32 watt, T-8 Bi-pin							
40 watt, T-12 Bi-pin							
40 watt, T-12 Single pin slimline	1 or 2	44	11	53 ³ / ₈	55	95	10 ¹ / ₄
60 watt, T-12 Recessed contact	3 or 4	46 ¹ / ₂	8 ¹ / ₂	53 ³ / ₈	55	100	10 ¹ / ₄
110 watt, T-12 Recessed contact							

No. of Lamps	Width
1-Lamp	6 ¹ / ₈
2-Lamp	11 ¹ / ₂
3-Lamp	18
4-Lamp	24 ¹ / ₂

Luminaire: All 1-Lamp EVF Luminaires

Lamp: 1-40/T-12, 1-60/T-12
 Zonal Degrees: 0-30 0-40 0-60 0-90
 Zonal Lumens: 580 953 1633 1897
 Total Bare Lamp Lumens: 3100

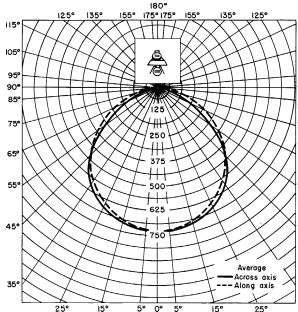

All data provided is for 40W rapid start cool white lamps. Use following candlepower/lumen multipliers for other lamp sizes:
 32W 0.90
 40W Slimline 0.84
 60W Cool white 1.29
 110W Cool white 2.19

Example: Zonal lumens of 1-40W lamp for 0-60° is 1633. Zonal lumens of 1-60W lamp for 0-60° is 1633 x 1.29 = 2107

Coefficient of Utilization

Effective Floor Cavity Reflectance 20%

% Reflectance Eff. Ceil.	Room Cavity Ratio	Room Cavity Ratio				
		Wall	1	2	3	4
80	50	.697	.616	.546	.485	.434
	30	.670	.574	.497	.430	.376
	10	.647	.539	.458	.388	.334
70	50	.682	.604	.538	.477	.425
	30	.658	.565	.490	.426	.372
	10	.635	.534	.454	.385	.331
50	50	.653	.580	.518	.460	.412
	30	.633	.549	.478	.416	.365
	10	.616	.520	.446	.380	.329
30	50	.627	.559	.500	.445	.399
	30	.612	.533	.467	.407	.357
	10	.597	.509	.438	.375	.325
10	50	.605	.539	.484	.431	.388
	30	.591	.517	.455	.397	.351
	10	.579	.498	.431	.370	.321
80	50	.391	.351	.316	.289	.252
	30	.334	.295	.262	.235	.198
	10	.294	.257	.223	.197	.164
70	50	.384	.346	.312	.285	.248
	30	.330	.292	.260	.233	.198
	10	.290	.255	.222	.197	.164
50	50	.372	.336	.303	.277	.242
	30	.324	.286	.255	.229	.195
	10	.288	.252	.221	.196	.162
30	50	.361	.325	.295	.270	.236
	30	.319	.283	.251	.225	.192
	10	.286	.249	.219	.194	.161
10	50	.351	.318	.287	.263	.230
	30	.312	.278	.247	.222	.189
	10	.283	.248	.218	.193	.159

Luminaire: All 2-Lamp EVF Luminaires

Lamp: 2-40/T-12, 2-38/T-12, 2-60/T-12, 2-110/T12
 Zonal Degrees: 0-30 0-40 0-60 0-90
 Zonal Lumens: 1055 1765 3262 4125
 Total Bare Lamp Lumens: 6300

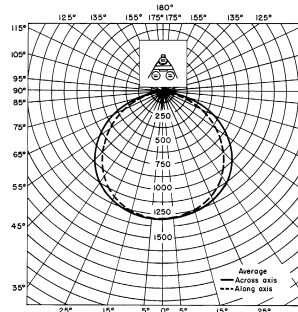

All data provided is for 40W rapid start cool white lamps. Use following candlepower/lumen multipliers for other lamp sizes:
 32W 0.90
 40W Slimline 0.84
 60W Cool white 1.29
 110W Cool white 2.19

Example: Zonal lumens of 2-40W lamp for 0-60° is 3262. Zonal lumens of 2-60W lamps for 0-60° is 3262 x 1.29 = 4208

Coefficient of Utilization

Effective Floor Cavity Reflectance 20%

% Reflectance Eff. Ceil.	Room Cavity Ratio	Room Cavity Ratio				
		Wall	1	2	3	4
80	50	.697	.616	.546	.485	.434
	30	.670	.574	.497	.430	.376
	10	.647	.539	.458	.388	.334
70	50	.682	.604	.538	.477	.425
	30	.658	.565	.490	.426	.372
	10	.635	.534	.454	.385	.331
50	50	.653	.580	.518	.460	.412
	30	.633	.549	.478	.416	.365
	10	.616	.520	.446	.380	.329
30	50	.627	.559	.500	.445	.399
	30	.612	.533	.467	.407	.357
	10	.597	.509	.438	.375	.325
10	50	.605	.539	.484	.431	.388
	30	.591	.517	.455	.397	.351
	10	.579	.498	.431	.370	.321
80	50	.391	.351	.316	.289	.252
	30	.334	.295	.262	.235	.198
	10	.294	.257	.223	.197	.164
70	50	.384	.346	.312	.285	.248
	30	.330	.292	.260	.233	.198
	10	.290	.255	.222	.197	.164
50	50	.372	.336	.303	.277	.242
	30	.324	.286	.255	.229	.195
	10	.288	.252	.221	.196	.162
30	50	.361	.325	.295	.270	.236
	30	.319	.283	.251	.225	.192
	10	.286	.249	.219	.194	.161
10	50	.351	.318	.287	.263	.230
	30	.312	.278	.247	.222	.189
	10	.283	.248	.218	.193	.159

5L

Luminaire: All 3-Lamp EVF Luminares

Lamp: 3-40/T-12, 3-38/T-12, 3-60/T-12, 3-110/T-12
 Zonal Degrees: 0-30 0-40 0-60 0-90
 Zonal Lumens: 1917 3226 6066 7919
 Total Bare Lamp Lumens: 9300

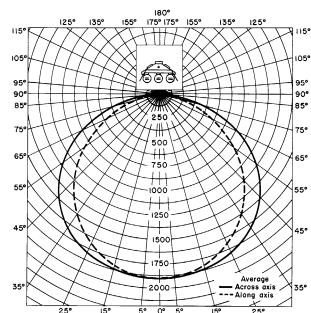

All data provided is for 40W rapid start cool white lamps. Use following candlepower/lumen multipliers for other lamp sizes:
 32W 0.90
 40W Slimline 0.84
 60W Cool white 1.29
 110W Cool white 2.19

Example: Zonal lumens of 3-40W lamps for 0-40° is 3226. Zonal lumens of 3-40W Slimline lamps for 0-40° is 3226 x 0.84 = 2710

Luminaire: All 4-Lamp EVF Luminares

Lamp: 4-40/T-12, 4-38/T-12, 4-60/T-12, 4-110/T-12
 Zonal Degrees: 0-30 0-40 0-60 0-90
 Zonal Lumens: 1961 3305 6250 8224
 Total Bare Lamp Lumens: 12400

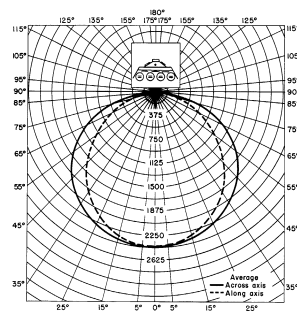

All data provided is for 40W rapid start cool white lamps. Use following candlepower/lumen multipliers for other lamp sizes:
 32W 0.90
 40W Slimline 0.84
 60W Cool white 1.29
 110W Cool white 2.19

Example: Zonal lumens of 4-40W lamps for 0-30° is 1961. Zonal lumens of 4-110W Slimline lamps for 0-30° is 1961 x 2.19 = 4295

Coefficient of Utilization

Effective Floor Cavity Reflectance 20%

% Reflectance	Room Cavity Ratio						
	Eff. Ceil.	Wall	1	2	3	4	5
80	50	.712	.626	.553	.489	.436	
	30	.683	.581	.500	.431	.376	
	10	.658	.544	.459	.386	.331	
70	50	.697	.614	.544	.481	.427	
	30	.670	.572	.494	.426	.371	
	10	.646	.539	.455	.383	.328	
50	50	.667	.589	.524	.463	.414	
	30	.645	.555	.481	.416	.364	
	10	.626	.524	.446	.378	.326	
30	50	.640	.567	.505	.447	.400	
	30	.623	.539	.469	.407	.356	
	10	.607	.513	.439	.374	.322	
10	50	.617	.547	.488	.433	.388	
	30	.602	.523	.457	.397	.350	
	10	.589	.502	.431	.368	.318	

% Reflectance	Room Cavity Ratio						
	Eff. Ceil.	Wall	6	7	8	9	10
80	50	.392	.352	.317	.289	.252	
	30	.332	.293	.260	.233	.196	
	10	.290	.254	.219	.194	.160	
70	50	.385	.347	.312	.285	.248	
	30	.329	.290	.258	.230	.196	
	10	.287	.251	.218	.194	.160	
50	50	.372	.336	.303	.277	.242	
	30	.322	.284	.253	.227	.193	
	10	.285	.248	.217	.192	.159	
30	50	.362	.325	.295	.269	.236	
	30	.317	.280	.248	.223	.190	
	10	.282	.245	.215	.191	.157	
10	50	.351	.317	.286	.262	.230	
	30	.310	.276	.244	.220	.187	
	10	.279	.244	.214	.189	.156	

Coefficient of Utilization

Effective Floor Cavity Reflectance 20%

% Reflectance	Room Cavity Ratio						
	Eff. Ceil.	Wall	1	2	3	4	5
80	50	.692	.607	.535	.473	.421	
	30	.664	.563	.484	.416	.362	
	10	.639	.526	.442	.372	.318	
70	50	.678	.595	.526	.465	.412	
	30	.652	.554	.477	.411	.357	
	10	.628	.521	.439	.369	.315	
50	50	.648	.571	.507	.447	.399	
	30	.627	.538	.465	.401	.351	
	10	.609	.507	.431	.364	.313	
30	50	.622	.550	.488	.432	.386	
	30	.606	.522	.453	.392	.343	
	10	.590	.497	.423	.360	.309	
10	50	.600	.530	.472	.418	.374	
	30	.585	.506	.442	.383	.337	
	10	.572	.486	.416	.354	.305	

% Reflectance	Room Cavity Ratio						
	Eff. Ceil.	Wall	6	7	8	9	10
80	50	.379	.340	.306	.279	.243	
	30	.320	.282	.250	.224	.189	
	10	.278	.243	.210	.185	.153	
70	50	.372	.335	.301	.275	.239	
	30	.316	.279	.248	.221	.189	
	10	.275	.240	.209	.185	.153	
50	50	.359	.324	.292	.267	.233	
	30	.310	.273	.243	.218	.185	
	10	.273	.238	.208	.184	.152	
30	50	.349	.313	.284	.260	.227	
	30	.305	.269	.238	.214	.182	
	10	.271	.235	.206	.183	.150	
10	50	.339	.306	.276	.253	.221	
	30	.298	.265	.235	.211	.179	
	10	.268	.234	.205	.181	.149	

5L EVFDR Series Fluorescent Luminaires

Cl. I, Div. 1, Groups C, D
Cl. I, Zone 1, Group IIB
Cl. II, Div. 1, Groups E, F, G
Cl. III, Simultaneous Presence

Marine & Wet
Locations
3, 3R, 4, 4X; IP66

Applications:

- EVFDR Luminaires are suitable for wet locations and marine environments, above and below deck, where hazardous vapors, gases or dusts are present
- Ideally suited for use on offshore drilling/production platforms and on shipboard in hazardous areas
- For mounting where headroom is limited
- For hazardous areas where watertightness and corrosion resistance are required

Features:

- Exterior surfaces finished with gray epoxy enamel for corrosion resistance
- Exterior hardware stainless steel
- All joints sealed and gasketed for watertightness
- Vibration resistant
 - Shock mounts
 - Sockets are spring loaded for tight lamp contact connection
- Heavy duty glass lamp tubes for maximum strength and impact resistance
- All exterior materials are non-sparking
- C-type beam clamps provide quick and easy mounting
- Luminaire is adjustable 30° either side of fixture axis, allowing for control of light output
- Beam clamp support is adjustable allowing beam clamp to be located to suit structure
- Low profile – luminaire height is 7¹³/₁₆" with standard mounting, 11¹/₁₆" with shock mounting option – for maximum clearance where headroom is critical
- Provides cool light with natural color rendition
- Continuous and uniform illumination made possible by mounting end to end (no space needed between luminaires for relamping) – see page 1113 for relamping information
- Relamping is accomplished without tools; quarter-turn fastener allows end of luminaire to be lowered quickly; cable supports end of luminaire while relamping – both hands are free; threaded lamp tube cover provides quick and easy access to lamp and receptacle
- Reflectors can be removed or replaced with only a screwdriver
- Ballast housing readily accessible
- Minimum weight – copper-free aluminum construction throughout
- Type P ballast furnished in compliance with NEC
- Standard electronic ballast for 32 watt and 40 watt rapid start

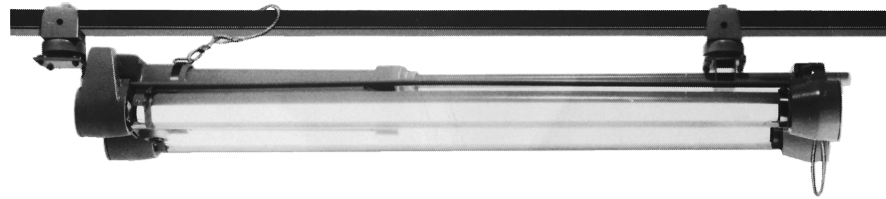

- Standard energy-efficient electromagnetic ballast (40W slimline, 60W and 110W) is standard
- Low temperature ballasts are standard on 32W T8, 40W slimline, 60W and 110W; 32 watt and 40 watt low temperature ballasts are rated for 0°F; 60 and 100 watt low temperature ballasts are rated for -20°F

Certifications and Complies:

- NEC and CEC:
 - Class I, Division 1, Groups C, D
 - Class I, Zone 1, Group IIB
 - Class II, Groups E, F, G
 - Class III
 - Simultaneous Presence (Cl. and Cl. II)
- UL Standards:
 - 844 Hazardous (Classified) Locations
 - 1598 Luminaires
 - 1598A Marine Locations
- CSA Standards:
 - C22.2 No. 137

Standard Materials:

- Housing – copper-free aluminum
- Exposed hardware – stainless steel

Standard Finishes:

- All exterior metal components – gray epoxy enamel
- Reflectors – white epoxy powder coat

Ordering Information:

Furnished For Use With	Hub Size	Line Volts 60 Hz.	2-Lamp Cat. #
32 watt, T-8 medium Bi-pin 265MA lamps	3/4"	120–277	EVFDR22029/UNV EVFDR22029/347
40 watt, T-12 medium Bi-pin rapid start 430MA lamps†	3/4"	110–125 277	EVFDR22082 EVFDR22087
60 watt, T-12 recessed contact, 800MA lamps	3/4"	110–125 277	EVFDR22062 EVFDR22067
110 watt, T-12 recessed contact, 1500MA lamps†	3/4"	110–125 277	EVFDR22072 EVFDR22077

†50 Hz not available.

Options:

- | Description | Suffix |
|---|--------|
| • Furnished with lamps..... | S714 |
| • Furnished with safety cable for high vibration areas..... | S715 |
| • Beam clamps with shock mounts are available for ease of installation and resistance to vibration..... | KIT40 |
| • Beam clamps only..... | KIT41 |
| • Low temperature electromagnetic ballast: 40W rapid start rated 0°F..... | BY |
| • Emergency lighting battery unit.... | S799 |

Size Ranges:

- 2-lamp only

Electrical Rating Ranges:

- 32, 40, 60 and 110W

Temperature Performance Data:

(Based on 40°C Ambient)

2-Lamp	Class I Class II Zone 1	Supply Wire
32, 40W	T5	75°C
60W	T5	75°C
110W	T4	90°C

EVFDR Series Fluorescent Luminaires

Luminaire: All EVFDR Luminaires

Lamp:	2-40/T-12, 2-60/T-12, 2-110/T-12
Zonal Degrees:	0-30 0-40 0-60 0-90
Zonal Lumens:	1416 2352 4263 5863
Total Bare Lamp Lumens:	8600

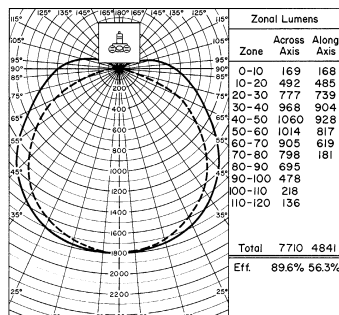

All data provided is for two 60 watt, T-12 recessed contact 800MA cool white lamps (EVFDR22062). For other wattages use the following conversion factors:

32W	.67
40W, Rapid Start	.73
40W, Slimline	.70
110W, Cool White	1.60

Example: Zonal lumens for EVFDR226 fixture, across the axis, for 40-50" is 1,060. Zonal lumens for EVFDR223 fixture, across the axis, is 40-50" is: 1,060 x .70 = 742

Coefficient of Utilization Effective Floor Cavity Reflectance 20%

% Reflectance Eff. Ceil.	Room Cavity Ratio	% Reflectance Eff. Wall				
		1	2	3	4	5
80	50	.735	.645	.570	.506	.452
	30	.700	.594	.512	.442	.387
	10	.670	.551	.466	.394	.339
70	50	.714	.627	.557	.494	.440
	30	.682	.580	.501	.435	.380
	10	.653	.542	.458	.388	.334
50	50	.673	.593	.528	.468	.420
	30	.647	.554	.482	.418	.368
	10	.624	.520	.444	.378	.327
30	50	.636	.562	.501	.446	.401
	30	.616	.530	.463	.403	.354
	10	.596	.502	.430	.368	.319
10	50	.603	.533	.477	.425	.383
	30	.585	.507	.444	.388	.343
	10	.570	.483	.416	.358	.311
0	0	.551	.465	.399	.340	.294

% Reflectance Eff. Ceil.	Room Cavity Ratio	% Reflectance Eff. Wall				
		6	7	8	9	10
80	50	.408	.368	.332	.304	.266
	30	.344	.305	.271	.243	.207
	10	.298	.262	.228	.202	.169
70	50	.398	.360	.325	.297	.260
	30	.338	.299	.267	.240	.206
	10	.293	.258	.226	.201	.168
50	50	.380	.344	.311	.285	.250
	30	.327	.289	.259	.233	.199
	10	.287	.252	.221	.197	.164
30	50	.364	.328	.299	.274	.240
	30	.317	.282	.251	.226	.193
	10	.281	.246	.217	.193	.160
10	50	.348	.316	.286	.263	.231
	30	.306	.274	.244	.220	.188
	10	.274	.241	.213	.189	.157
0	0	.259	.226	.198	.175	.144

Dimensions:

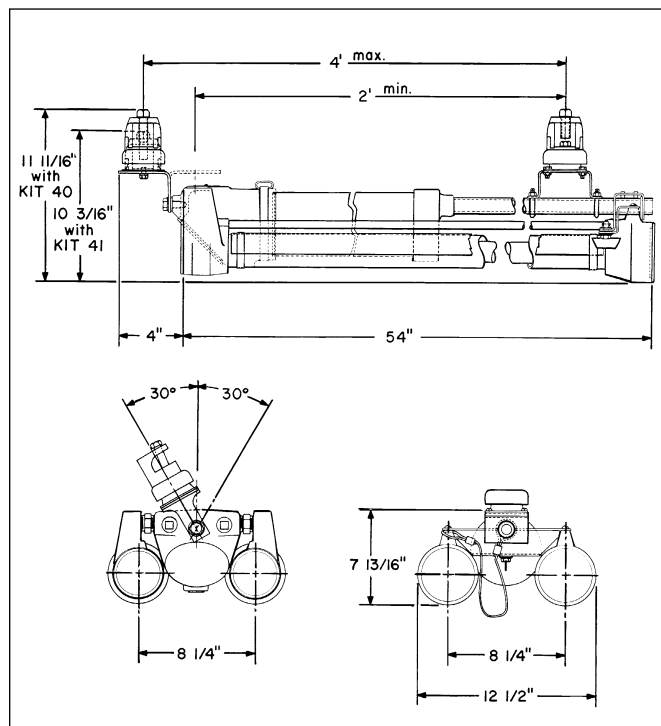

5L

5L

Champ-Pak™ Wall Pack & Floodlight Luminaires Hazardous and Non-hazardous

6L

Description	Page No.
Application/Selection	see page 1120
Floodlights	
Champ-Pak™	
CPMV	see page 1121
H.I.D.	
FMV nR Series	see pages 1135–1138
FMV1000 nR High Wattage Series	see pages 1139–1141
Voyager nR™ Stainless Steel Series	see pages 1142–1145
F2MV Mini Floodlight Series	see pages 1150–1153
FZD Series	see pages 1154–1156
EVMA S812 Hazard•Gard with Trunnion Arm	see page 1157
Incandescent	
RCDE Series	see pages 1158–1159
LED	
Champ® Pro PFM Series	see pages 1128–1129
Champ® Pro PFM25L and 50L Series	see pages 1130–1132
Champ® FMV Series	see pages 1146–1149



Applications:

- General illumination of hazardous and non-hazardous areas

**Table 500.8(C)
Identification Numbers**

Maximum Temperature		Temperature Class (T Code)
Deg. C	Deg. F	
450	842	T1
300	572	T2
280	536	T2A
260	500	T2B
230	446	T2C
215	419	T2D
200	392	T3
180	356	T3A
165	329	T3B
160	320	T3C
135	275	T4
120	248	T4A
100	212	T5
85	185	T6

Considerations for Selection:

Environmental:

- What is the hazardous area classification NEC®/CEC) of the location in which the luminaires will be installed?

Lighting levels required:

- What wattage luminaire(s) will provide the desired light levels?

Physical arrangement:

- Type of luminaire mounting required, threaded hub or mounting feet

Quick Selector Chart

Luminaire	NEC Hazardous Area Compliance	Lamp Size (Watts)	Lamp Base
CPMV	Cl. I, Division 2	50–150 HID	Mogul
EVMA-S812	Cl. I, Groups C, D Cl. I, Groups B (suffix GB), C, D	50–400 HID	Mogul
VOYAGER nR (SSFMV)	Cl. I, Division 2 Cl. I, Zone 2	150–400 HID	Mogul
F2MV, FMV, FMV High Wattage	Cl. I, Division 2	70–1500 HID	Mogul
FZD	Cl. I, Division 1, Groups B, C, D	150–400 HID	Mogul
RCDE-6	Cl. I, Groups C, D Cl. I, Group D	150 Incandescent 300 Incandescent	Medium
RCDE-10	Cl. I, Group D	500 Incandescent	Extended Mogul End Prong
PFM	Non-hazardous areas	64–179 LED	
PFM25L/PFM50L	Non-hazardous areas	263–531 LED	
FMV	Cl. I, Division 2, Groups A, B, C, D Cl. I, Zone 2 Cl. II, Groups E, F, G Cl. III	64–179 LED	

6L

Champ-Pak™ Wall Pack Luminaires

Cl. I, Div. 2, Groups A, B, C, D
Restricted Breathing Cl. I, Div. 2 &
Zone 2 (Suffix S826)
Certified for IEC Zone 2
(Suffix S826TB)

Cl. II, Groups F, G
Cl. III & Simultaneous Presence
Marine & Wet Locations
Enclosure Type 4X, IP66

6L

The first low-profile wall pack designed specifically for hazardous areas.

The Eaton's Crouse-Hinds Champ-Pak™ Wall Pack Luminaire is ideal for low-profile mounting in hazardous and industrial environments. **In fact, it is suitable for any area with adverse conditions such as dust, dirt, moisture, vibration, high-pressure hose downs, and high thermal ambients.** Its precisely designed glass refractor minimizes fixture depth while providing uniform, glare-free illumination.

- Unique compact shallow-profile design mounts virtually anywhere
- Side-hinged cover with two-screw closing for easy installation and maintenance
- Gray Corro-free™ epoxy powder coated two-piece housing provides superior corrosion resistance
- Unique stainless steel wire guard accessory attaches without any additional hardware for easy installation and maintenance
- Glass refractor provides uniform light distribution to eliminate glare
- Vertical lamp design provides even lamp heat distribution for cooler operation, providing expanded hazardous area suitability
- Silicone gaskets make luminaire suitable for enclosure Type 4X, marine, and IP66 environments
- Available in two different conduit entry configurations to permit flexible installation and mounting
- Four 3/4" NPT hubs, one on each side
- Two 1/2" NPT hubs on bottom for feed-through applications



Applications:

- Indoor and outdoor wall mounting or vertical surface mounting where minimal fixture depth is required in:
- Manufacturing plants and heavy industrial facilities
- Industrial process facilities such as refineries, chemical, petrochemical, pharmaceutical, and production platforms
- Waste or sewage treatment plants
- Offshore, dockside, and harbor installations
- For security and safety lighting in industrial facilities
- For lighting of loading docks, tunnels, and stairways
- For marine, wet location, hose down, and corrosive environments

Additional Features and Benefits:

- Variety of lamp types and wattages—HID, fluorescent, and induction—to meet specific lighting needs
- High power-factor ballasts (+90%) are standard, which allow more luminaires per circuit
- Up to 65°C ambient suitability on select lamp types and wattages; ambient suitability of +40°C is standard; allows for installation in higher ambient environments commonly found in industrial facilities
- Low ambient starting capability (to -40°C) – perfect for colder climates
- Shock-absorbing HID mogul base lamp socket cushions lamp, improves lamp life in harsh environments
- Compact fluorescent emergency luminaire provides 90 minutes of lighting during power outages, meeting UL924 and Life Safety Code
- Cost-effective induction lamp system provides extra long lamp life up to 100,000 hours; reaches full illumination immediately, providing crisp, white light
- NEC/CEC restricted breathing construction is available to provide cooler temperature classes (T codes) for expanded hazardous area suitability
- Simplified method for compliance to NEC restricted breathing conduit sealing requirements makes installation easier

Cl. I, Div. 2, Groups A, B, C, D
Restricted Breathing Cl. I,
Div. 2 & Zone 2 (Suffix S826)
Certified for IEC Zone 2
(Suffix S826TB)

Cl. II, Groups F, G
Cl. III & Simultaneous Presence
Marine & Wet Locations
Enclosure Type 4X, IP66

Certifications and Compliances:

- Luminaires For Use With ANSI Lamps (Mogul Base):
 - UL/cUL Listed
 - NEC and CEC Class I, Division 2 and Class I, Zone 2
 - Restricted Breathing Class I, Division 2 and Zone 2 (suffix S826)
 - Class II, Groups F, G
 - Class III
 - Simultaneous Presence
 - Certified for IEC Zone 2 (suffix S826TB)
 - Wet Locations; Marine Locations; Enclosure Type 4X; IP66
- UL Standards:
 - 844 – Hazardous (Divisions Classified) Locations
 - 1598 – Luminaires
 - 1598A – Luminaires for Marine Vessels
 - 924 – Emergency Lighting (Fluorescent Emergency Luminaire)
- CSA Standards:
 - C22.2 No. 9 and 137
 - CAN/CSA-E60079-15:02
- IEC Standards:
 - 60079-15

Standard Materials:

- Fixture housing and door frame assembly – copper-free aluminum
- External hardware – stainless steel
- Refractor lens – borosilicate glass
- Gasket – silicone
- Reflector – aluminum light sheet
- Wire guard – stainless steel

Standard Finishes:

- Aluminum – Corro-free™ epoxy powder coat
- Stainless steel – natural

Ratings (Electrical/Size):**Sources/Wattages**

- High-pressure sodium (HPS) – mogul base 50, 70, 100 & 150
- Metal halide (MH) – mogul base 70, 100 & 150
- Compact fluorescent 26, 32, 42, 52, 64 & 84
- Emergency fluorescent 26
- Induction 55 & 85

Voltages**HID Standard-Voltage Ballasts**

- Dual tap (120 & 277 V, 60 Hz–for 50 W HPS only)–prewired at 277 V
- Multi-tap (120, 208, 240 & 277 V, 60 Hz)–prewired at 277 V
- Tri-tap (120, 277 & 347 V, 60 Hz)–prewired at 347 V
- 120 V, 60 Hz
- 480 V, 60 Hz

Fluorescent Standard Voltage Ballasts

- 120–277 V, 50–60 Hz
- 120 V, 50 Hz (for Canada only)
- 347 V, 60 Hz (for Canada only)

Induction Standard Voltage Ballasts

- 120 V, 50–60 Hz (also 120 V DC)
- 230 V, 50–60 Hz (also 240 V DC)

HID Optional Voltage Ballasts

- 220 V, 50 Hz
- 220 V, 60 Hz
- 240 V, 50 Hz

Fluorescent Optional Voltage Ballasts (Consult Factory)

- 125 V DC
- 12 V DC
- 24 V DC

Isolated Ballasts And Specials (Consult Factory)

- 208 V, 60 Hz CWI Isolated Ballast
- 240 V, 60 Hz CWI Isolated Ballast
- 480 V, 60 Hz CWI Isolated Ballast

Conduit Entries

- Four 3/4" NPT entries, one on each side, top and bottom (3 plugged)
- Two 1/2" NPT entries on bottom for feed-through (1 plugged)
- Metric entries – consult factory

Champ-Pak™ Wall Pack Luminaires

Cl. I, Div. 2, Groups A, B, C, D
 Restricted Breathing Cl. I,
 Div. 2 & Zone 2 (Suffix S826)
 Certified for IEC Zone 2
 (Suffix S826TB)

Cl. II, Groups F, G
 Cl. III & Simultaneous Presence
 Marine & Wet Locations
 Enclosure Type 4X, IP66

6L

Ordering Information HID Luminaires:

Hub Size	Lamp Watts	Cat. #
High-Pressure Sodium		
Four 3/4" NPT (one each side) Two 1/2" NPT (on bottom)	50	CPMVS2W050 CPMVS1W050
Four 3/4" NPT (one each side) Two 1/2" NPT (on bottom)	70	CPMVS2W070 CPMVS1W070
Four 3/4" NPT (one each side) Two 1/2" NPT (on bottom)	100	CPMVS2W100 CPMVS1W100
Four 3/4" NPT (one each side) Two 1/2" NPT (on bottom)	150 (for 55 V lamp)	CPMVS2W150 CPMVS1W150
Metal Halide		
Four 3/4" NPT (one each side) Two 1/2" NPT (on bottom)	70	CPMVM2W070 CPMVM1W070
Four 3/4" NPT (one each side) Two 1/2" NPT (on bottom)	100	CPMVM2W100 CPMVM1W100
Metal Halide-Pulse Start		
Four 3/4" NPT (one each side) Two 1/2" NPT (on bottom)	150	CPMVM2W150 S828 CPMVM1W150 S828

To complete Catalog Number, add Voltage and Option suffix(es).

Voltage Suffixes:

		NEC/UL			
Voltage (60 Hz)	Dual Tap	Multi Tap	120	480	
Suffix	/DT	/MT	/120	/480	
		CEC (CSA/cUL)			
Voltage (60 Hz)	Dual Tap	Tri Tap	120		
Suffix	/DT	/TT	/120		

50W HPS is available only with suffix /DT.

Ordering Information Induction Luminaires With Lamp (100,000 hours):

Hub Size	Lamp Watts	Cat. #
Four 3/4" NPT (one each side) Two 1/2" NPT (on bottom)	55	CPMVG2W055 CPMVG1W055
Four 3/4" NPT (one each side) Two 1/2" NPT (on bottom)	85	CPMVG2W085 CPMVG1W085

Voltage Suffixes:

		120 V (also 120 V DC)	230 V (also 240 V DC)
Voltage (50-60 Hz)			
Suffix	/120		/230

Ordering Information Fluorescent Luminaires:

Hub Size	Lamp Watts	Cat. #
Four 3/4" NPT (one each side) Two 1/2" NPT (on bottom)	26 (one 26 W lamp)	CPMVF2W026 CPMVF1W026
Four 3/4" NPT (one each side) Two 1/2" NPT (on bottom)	32 (one 32 W lamp)	CPMVF2W032 CPMVF1W032
Four 3/4" NPT (one each side) Two 1/2" NPT (on bottom)	42 (one 42 W lamp)	CPMVF2W042 CPMVF1W042
Four 3/4" NPT (one each side) Two 1/2" NPT (on bottom)	52 (two 26 W lamps)	CPMVF2W052 CPMVF1W052
Four 3/4" NPT (one each side) Two 1/2" NPT (on bottom)	64 (two 32 W lamps)	CPMVF2W064 CPMVF1W064
Four 3/4" NPT (one each side) Two 1/2" NPT (on bottom)	84 (two 42 W lamps)	CPMVF2W084 CPMVF1W084

Voltage Suffixes:

		NEC/CEC (UL, CSA, cUL)	CEC (CSA, cUL)
Voltage		120-277 V	347 V
Suffix		(50-60 Hz) /UNV	(60 Hz) /347

Ordering Information Fluorescent Emergency Luminaires - Continuous Operation:

Hub Size	Lamp Watts	Cat. #
Four 3/4" NPT (one each side) Two 1/2" NPT (on bottom)	26 (one 26 W lamp)	CPMVF2W026 CPMVF1W026

Voltage Suffixes:

		NEC/CEC (UL, CSA, cUL)	CEC (CSA, cUL)	
Voltage		120-277 V	120 V	347 V
Suffix		(50-60 Hz) /UNV	(60 Hz) /120 CAN	(60 Hz) /347

Compelling reasons to choose the Champ induction luminaire as the light source for industrial and hazardous locations include:

- Crisp, white light (80+ color rendering index) provides increased safety by clearly illuminating signs, instrument panels, equipment, and more with vibrant natural colors
- Up to 100,000 hours of lamp life minimizes routine maintenance costs; if you operate this luminaire for 24 hours, 7 days a week, you will not need to change the lamp for up to 11 years!
- Instant illumination - no waiting for lamp warm-up time; increases productivity and safety
- Delivers the best possible luminaire temperature rating - T6 (85°C) when used with the Champ restricted breathing option; ideal for hazardous areas where a low ignition temperature is required
- Starts in low temperatures - as low as -40°C

6L Champ-Pak™ Wall Pack Luminaires

Cl. I, Div. 2, Groups A, B, C, D
 Restricted Breathing Cl. I,
 Div. 2 & Zone 2 (Suffix S826)
 Certified for IEC Zone 2
 (Suffix S826TB)

Cl. II, Groups F, G
 Cl. III & Simultaneous
 Presence
 Marine & Wet Locations;
 Enclosure Type 4X, IP66

Options:

Description	Suffix
Ballast-Gard™ starter cut-out switch	BG
• Not available with IR or QTZ options	
Factory Assembled with Lamp Installed	FA
Instant Restrike	IR
• Not available with BG or QTZ options	
Guard—Factory Installed on Luminaire	P
(Guard suffix follows wattage designation, e.g., CPMVS2W100P/MT)	
Quartz Auxiliary	QTZ
Fused	S658*
• Not available with CPMVIG and CPMVFB luminaires	
• Not suitable for marine applications	
Restricted Breathing Construction (AEx nR, Ex nR)	S826
Certified For IEC Zone 2 (Ex nR) (UL Classified to the IEC Standard)	S826TB
Furnished with:	
• 4 mm ² , 3-point terminal block	
• Crimp internal wiring connections	
• P55 guard	
V2PC Photocell—Factory Installed	
• 120 V, 50–60 Hz.....	/V2PC20
• 208–240 V, 50–60 Hz.....	/V2PC22
• 277 V, 50–60 Hz.....	/V2PC27
Optional Voltage Ballasts for HID Luminaires	
• 220 V, 50 Hz.....	/220 50
• 220 V, 60 Hz.....	/220 60
• 240 V, 50 Hz.....	/240 50
Optional Voltage Ballasts for Fluorescent Luminaires (Consult Factory)	
• 125 V DC.....	/125 VDC
• 12 V DC.....	/12 VDC
• 24 V DC.....	/24 VDC
Isolated Ballast for HID Luminaires (Consult Factory)	
• 208 V, 60 Hz.....	/208CWI
• 240 V, 60 Hz.....	/240CWI
• 480 V, 60 H.....	/480CWI

Accessories:

(Order Separately) Description	Cat. #
Photocell For Field Installation	
• 120 V, 50–60 Hz	V2PC20
• 208–240 V, 50–60 Hz	V2PC22
• 277 V, 50–60 Hz	V2PC27
In Canada, use factory-installed photocell only.	
Stainless Steel Wire Guard	P55

6L

*When ordering fuses for luminaires, option S658, you must specify the operating voltage. S658 cannot be ordered with /MT in the catalog number.

TEFLON is a registered trademark of E.I. duPont Co.

Dimensions (In Inches):

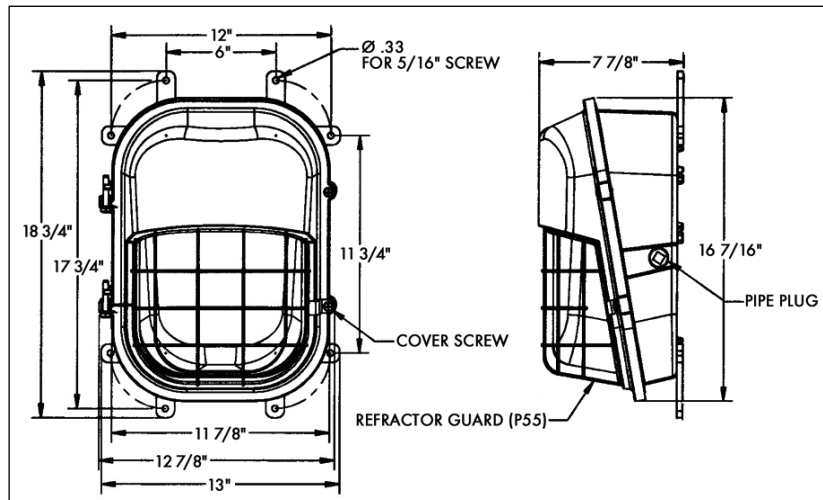

Note: Approximate weight less guard 28 lbs. P55 guard 0.5 lbs.

CPMV Photometric Data

Luminaire With Refractor Less Wire Guard

CPMVS2W150 Lamp: 150 W/E23-½ Clear High Pressure Sodium (HPS)

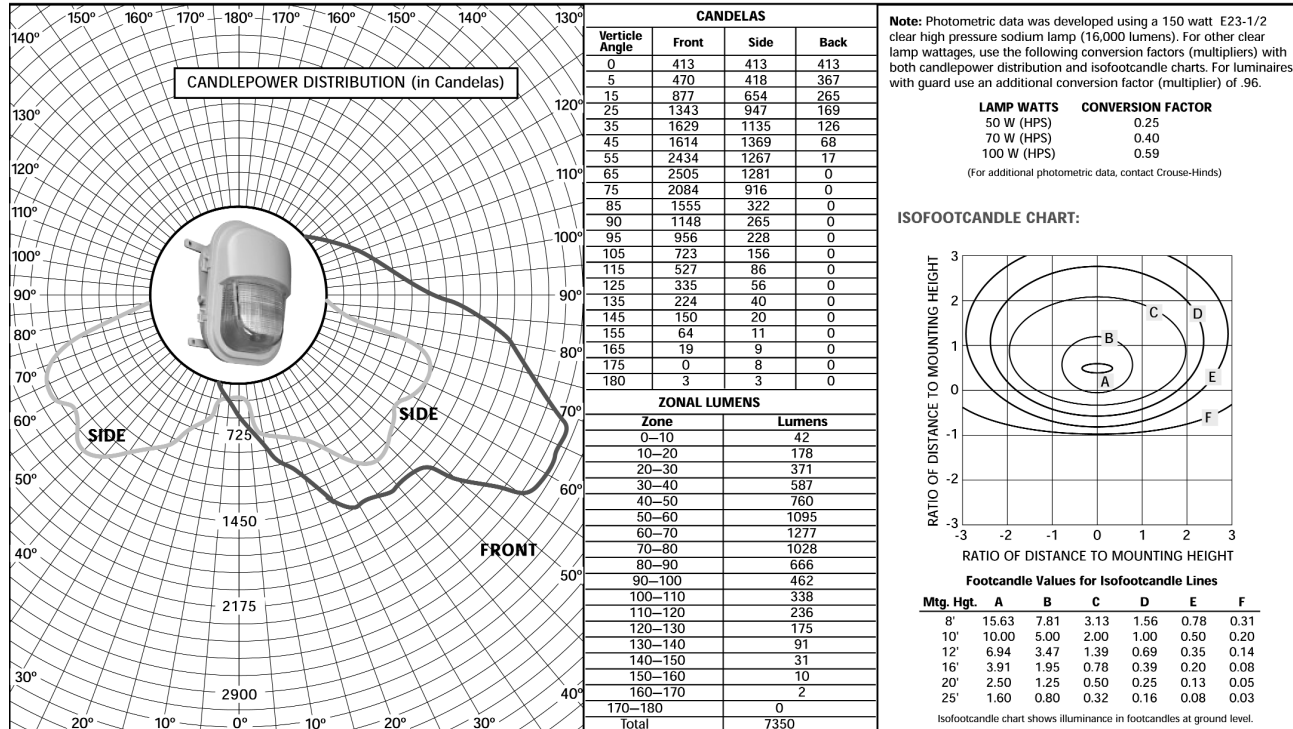

Note: Photometric data was developed using a 150 watt E23-1/2 clear high pressure sodium lamp (16,000 lumens). For other clear lamp wattages, use the following conversion factors (multipliers) with both candlepower distribution and isofootcandle charts. For luminaires with guard use an additional conversion factor (multiplier) of .96.

LAMP WATTS	CONVERSION FACTOR
50 W (HPS)	0.25
70 W (HPS)	0.40
100 W (HPS)	0.59

(For additional photometric data, contact Crouse-Hinds)

ISOFOOTCANDLE CHART:

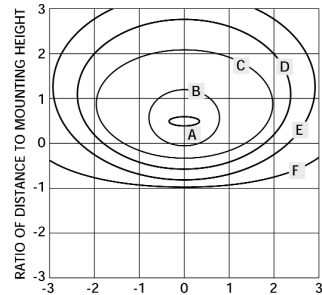

Luminaire With Refractor Less Wire Guard

CPMVM2W150-S828 Lamp: 150 W/ED28 Clear Pulse Start Metal Halide

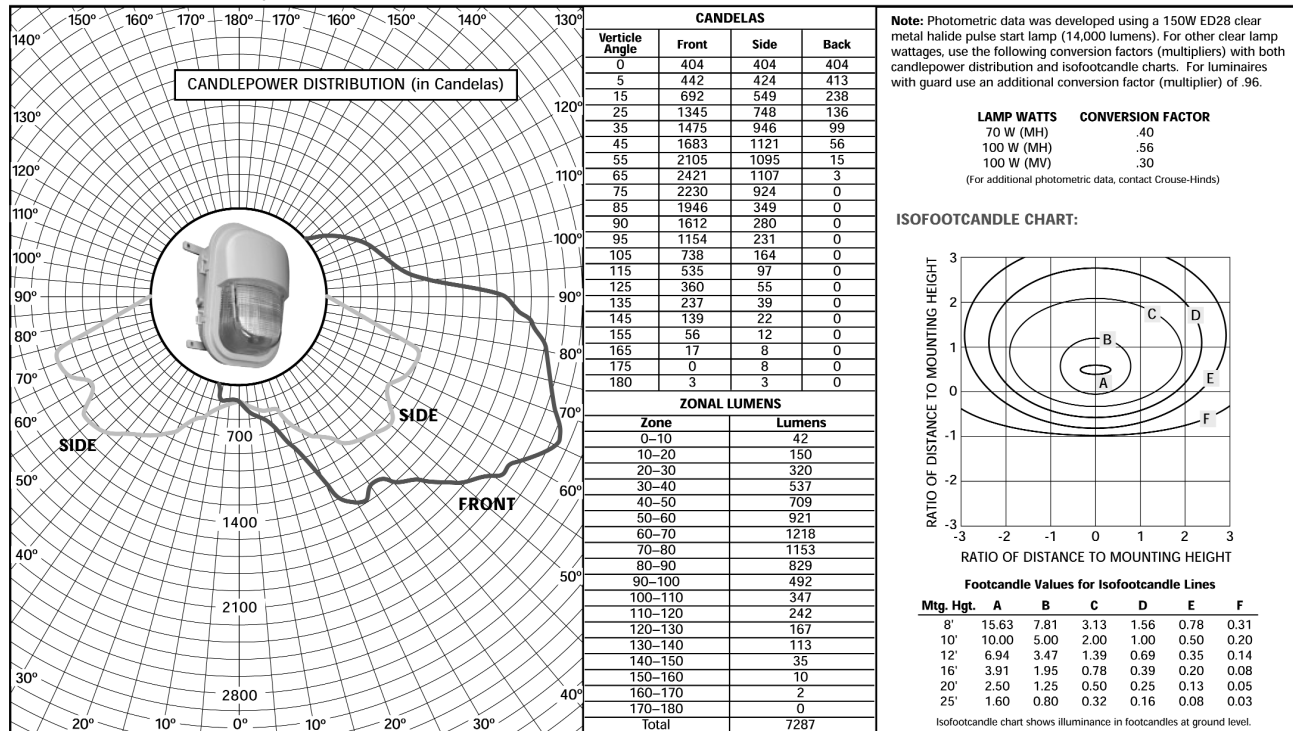

Note: Photometric data was developed using a 150W ED28 clear metal halide pulse start lamp (14,000 lumens). For other clear lamp wattages, use the following conversion factors (multipliers) with both candlepower distribution and isofootcandle charts. For luminaires with guard use an additional conversion factor (multiplier) of .96.

LAMP WATTS	CONVERSION FACTOR
70 W (MH)	.40
100 W (MH)	.56
100 W (MV)	.30

(For additional photometric data, contact Crouse-Hinds)

ISOFOOTCANDLE CHART:

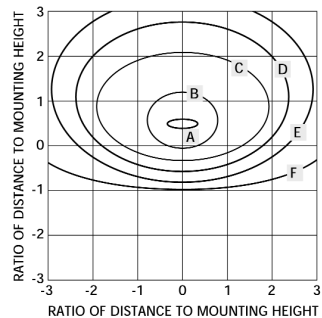

For additional photometric data, contact Eaton's Crouse-Hinds.

Luminaire With Refractor Less Wire Guard

CPMVF2W084 Lamps: (2) PL-T 42W/30/4P Compact Fluorescent

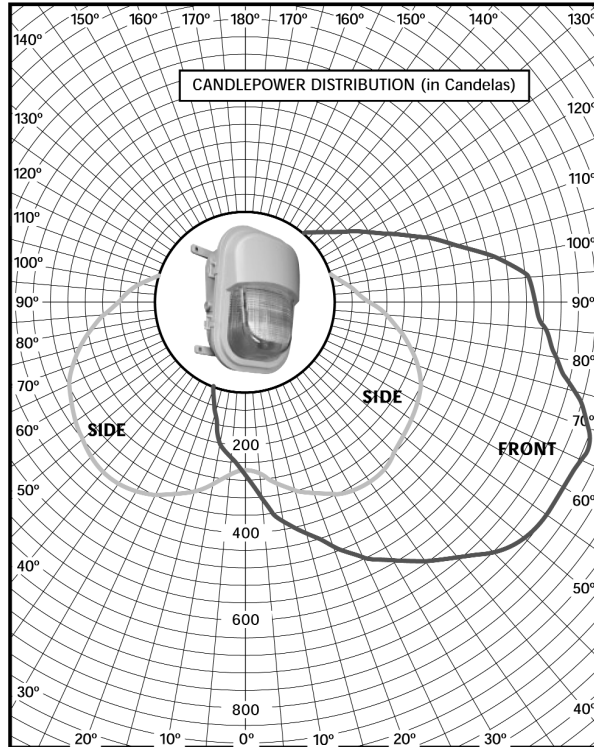

CANDELAS			
Verticle Angle	Front	Side	Back
0	258	258	258
5	319	269	227
15	421	316	139
25	516	361	58
35	590	376	33
45	671	362	10
55	720	347	0
65	725	317	0
75	657	264	0
85	566	195	0
90	541	160	0
95	526	132	0
105	409	86	0
115	277	49	0
125	145	31	0
135	97	21	0
145	52	11	0
155	34	3	0
165	8	1	0
175	0	0	0
180	0	0	0

ZONAL LUMENS	
Zone	Lumens
0-10	26
10-20	87
20-30	155
30-40	223
40-50	286
50-60	334
60-70	357
70-80	349
80-90	309
90-100	262
100-110	188
110-120	113
120-130	64
130-140	36
140-150	16
150-160	5
160-170	0
170-180	0
Total	2810

Note: Photometric data was developed using two clear fluorescent lamps (3,200 lumens each). For other clear lamp wattages, use the following conversion factors (multipliers) with both candlepower distribution and isofootcandle charts. For luminaires with guard use an additional conversion factor (multiplier) of .96.

LAMP WATTS	CONVERSION FACTOR
52 W (MH)	.56
64 W (MH)	.75

(For additional photometric data, contact Crouse-Hinds)

ISOFOOTCANDLE CHART:

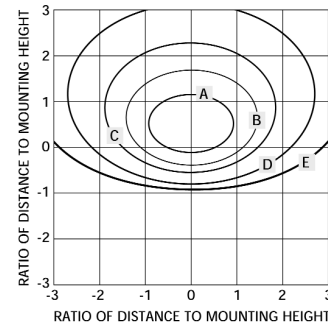

Footcandle Values for Isofootcandle Lines

Mtg. Hgt.	A	B	C	D	E
8'	3.13	1.56	0.78	0.31	0.16
10'	2.00	1.00	0.50	0.20	0.10
12'	1.39	0.69	0.35	0.14	0.07
16'	0.78	0.39	0.20	0.08	0.04
20'	0.50	0.25	0.13	0.05	0.03
25'	0.32	0.16	0.08	0.03	0.02

Isofootcandle chart shows illuminance in footcandles at ground level.

For additional photometric data, contact Eaton's Crouse-Hinds.

Temperature Performance Data:

Watts	Ambient Temp.°C	Class I Division 2 and Zone 2		Class II and Class III	Simultaneous Presence Class I/Class II (Gas and Dust Present in the Same Area)		Supply Wire Temp.°C
		Standard Product	Restricted Breathing AEx nR/Ex nR Option S826		Standard Product Suitable for Class I, Division 2/Class II	Restricted Breathing AEx nR/Ex nR Option S826 Suitable for Class I, Division 2 or Zone 2 and Class II	
HIGH PRESSURE SODIUM							
50	40	T3A	T6	T5	T3A/T5	T5	90
	55	T3A	T6	T4A*	T3/T4A*	T4*	105
	65*	T3	T5	—	—	—	105
70	40	T3A	T6	T5	T3A/T5	T5	90
	55	T3A	T6	—	—	—	105
	65*	T3	T5	—	—	—	105
100	40	T2C	T5	Consult Factory for Class II Suitability with			90
	55*	T2C	T4	105°C Supply Wire			105
150	40	T2B	T4	—	—	—	105
METAL HALIDE							
70	40	T3C	T6	T5	T3C/T5	T5	90
	55	T3C	T6	—	—	—	105
	65*	T3C	T5	—	—	—	105
100	40	T3	T6	—	—	—	90
150PS (S828)	40	T2D	T5	—	—	—	105
COMPACT FLUORESCENT							
26	40	T3B	T6	T6	T3B/T6	T6	75
26 (347 V)	55	T3A	T6	—	—	—	75
	40	T3	T6	—	—	—	75
32	40	T3B	T6	T6	T3B/T6	T6	75
	55	T3A	T6	—	—	—	75
32 (347 V)	40	T3	T6	—	—	—	75
42 (120–277 V)	40	T3B	T6	T6	T3B/T6	T6	75
42 (347 V)	55	T3A	T6	—	—	—	75
	40	T3	T6	—	—	—	75
52	40	T3	T6	T6	T3B/T6	T6	75
	55	T3	T6	—	—	—	90
64	40	T3	T6	T6	T3/T6	T6	75
	55	T3	T6	—	—	—	90
84	40	T2C	T6	—	—	—	90
EMERGENCY FLUORESCENT							
26	40*	T3B	T6	—	—	—	75
INDUCTION							
55	40*	T2D	T6	T6	—	T6	75
	55*	T2D	T6	—	—	—	75
85	40*	T2B	T6	—	—	—	75

*Fuses (suffix S658) are not available for indicated light sources and ambient temperatures.

Note: Luminaires requiring 105°C supply wire are furnished with 3 ft. of rated wire for external wiring connection.



6L

Champ® Pro PFM Series Luminaires

UL/cUL Listed
NEMA 4X
IP66

**Perfect for outdoor/indoor flood
illumination**

The Champ® Pro PFM Family

Champ® Pro PFM Series Floodlights are designed to provide full-spectrum, crisp, white light. Five versions of the Champ PFM LED are available, providing ideal solutions for a wide range of applications.

Champ® Pro PFM Model	Equivalent MH HID Lamp	Energy Savings
PFM5L	100W-150W	Up to 62%!
PFM7L	150W-175W	
PFM9L	175W-250W	
PFM11L	250W-400W	
PFM13L	400W	

Certifications and Complies:

- UL1598
- UL1598A
- cUL
- NEMA 4X; IP66
- DesignLights Consortium® approved for select models (refer to Ordering Information for details)

Drivers:

Model	5L - 13L
Standard	90-305 VAC, 50 / 60 Hz; 108-250 VDC
Option 1	347 VAC Model
Option 2	480 VAC Model

Standard Materials:

- Housing – copper-free aluminum with Corro-free™ epoxy powder coat
- Lens – shatter-resistant glass
- Gaskets – silicone
- External hardware – stainless steel
- Factory-sealed, no external seals required

LED System:

- High brightness light emitting diode (LED) arrays
- Color temperature: 3000K (CRI 82) and 5600K (CRI 65) options available
- Advanced heat sink design ensures LED does not exceed manufacturer's temperature ratings across all specified ambient conditions



Electrical Ratings:

	PFM5L	PFM7L	PFM9L	PFM11L	PFM13L
Voltage Range, VAC	100-277V 50-60 Hz 347 / 480V 60 Hz				
Voltage Range, VDC	108-250	108-250	108-250	108-250	108-250
Input Power (Nom.)	64	89	121	149	179
Input Amps (Max.)	0.550	0.800	1.083	1.608	1.608
Power Factor	>0.85	>0.85	>0.85	>0.85	>0.85

Ordering Information:

Color Temperature	5L Series	7L Series	9L Series	11L Series	13L Series
Cool Color Temperature	PFM5LCY/UNV1 76	PFM7LCY/UNV1 76	PFM9LCY/UNV1 76	PFM11LCY/UNV1 76	PFM13LCY/UNV1 76
	PFM5LCY/120 76*	PFM7LCY/120 76*	PFM9LCY/120 76*	PFM11LCY/120 76*	PFM13LCY/120 76*
Warm Color Temperature	PFM5LWY/UNV1 76	PFM7LWY/UNV1 76	PFM9LWY/UNV1 76	PFM11LWY/UNV1 76	PFM13LWY/UNV1 76

For 347 VAC option, replace /UNV1 with /347. For 480 VAC option, replace /UNV1 with /480.

To order fixture without optics, remove '76' from the end of the catalog number.

*5 year limited warranty. Refer to page 2 of the D-0413 authorized distributor price book for Eaton's Crouse-Hinds standard Terms and Conditions. DesignLights Consortium approved models. Cool white only.

Options:

Description	Suffix
Fused (only applies to UNV1 model, not available for 347V or 480V; NOT marine or cUL Listed)	S658
Two conduit/cable glands of like thread installed	S886

Accessories:

Description	Catalog No. Sold Separately
Bolt-on visor (sold separately)	DSV1
Bolt-on wire guard (sold separately)	P61
Floodlight slipfitter (sold separately)	SFA6
Slipfitter wall mount adapter (sold separately)	SWB6

Crouse-Hinds
by **E.T.N.**

Champ® Pro PFM Series Luminaires

UL/cUL Listed
NEMA 4X
IP66

6L

Perfect for outdoor/indoor flood illumination

Dimensions:

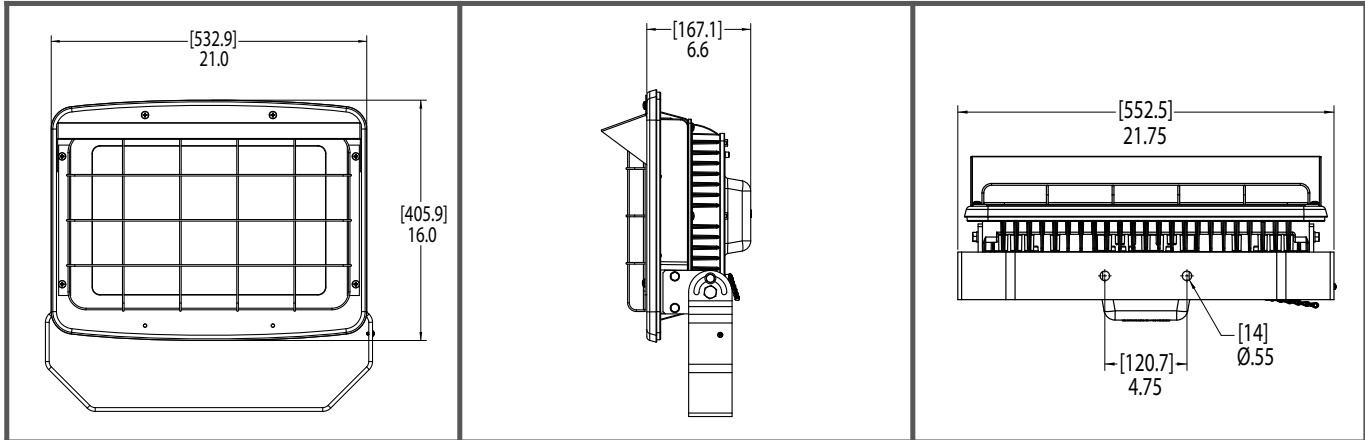

Weights:

Model	Lbs.
5L	39.11
7L	39.16
9L	39.73
11L	40.35
13L	40.35

Ambient Temperature:

Champ® Pro PFM Model	Max. Temp. °C
PFM5L	55
PFM7L	55
PFM9L	55
PFM11L	40
	55
PFM13L	40
	55

Photometric Data:

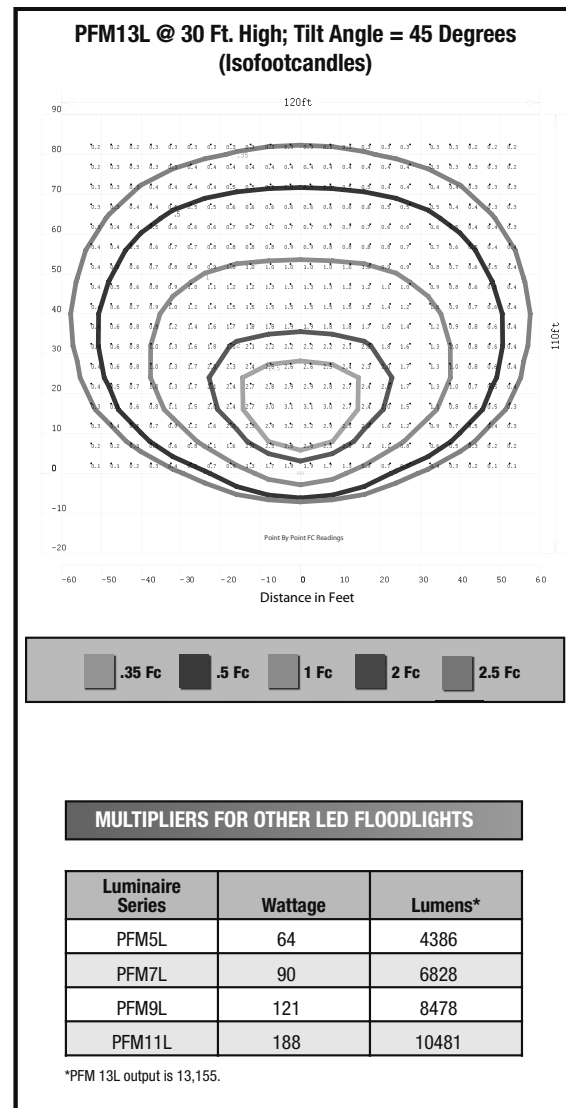

6L

The Champ® Pro PFM LED Family

PFM LED Series Floodlights are designed to provide full-spectrum, crisp, white light. Two versions of the Champ Pro PFM LED are available, providing ideal solutions for a wide range of applications.

PFM Model	Equivalent HID Lamp	Energy Savings
PFM25L	750W MH	Up to 65%!
PFM50L	1500W MH / 1000W HPS	

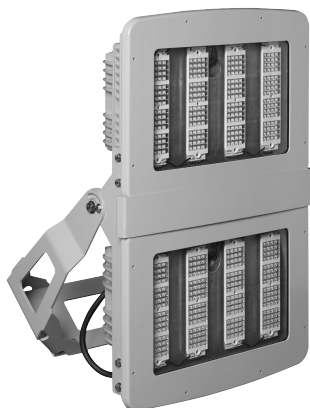

PFM50L Model



PFM25L Model

Applications:

- High lumen output for installation in high mounting heights
- Locations requiring continuous and consistent light levels
- Areas requiring frequent on-and-off of lights
- Where extremely corrosive, wet, dusty, hot and/or cold conditions exist; indoors or outdoors
- NEMA 4X, marine, wet locations, and hose-down environments
- Indoor and outdoor area lighting in plants, buildings, and parking areas
- Manufacturing plants; heavy industrial, chemical, petrochemical or pharmaceutical facilities; platforms; loading docks; outdoor mounted general area lighting
- Ball mills, stackers and reclaimers, concentrators, smelters, mine roadways, outdoor processing areas, truck service shops, shovels, and drag lines

Standard Materials:

- Housing – copper-free aluminum with Corro-free™ epoxy powder coat
- Lens – heat- and impact-resistant glass
- Yoke mount (standard) – copper-free aluminum with Corro-free™ epoxy powder coat
- Gaskets – silicone
- External hardware – stainless steel
- Factory-sealed, no external seals required

LED System:

- High brightness light emitting diodes (LEDs)
- Color temperature: 5000K (CRI 67)
- Advanced heat sink design ensures LED does not exceed manufacturer's temperature ratings across all specified ambient conditions
- LM-79, LM-80 reports available upon request

Electrical Ratings:

	PFM25L	PFM50L
Voltage Range, VAC	120-277V 50 / 60 Hz	
Voltage Range, VDC	277-480V 50 / 60 Hz	
Input Power (Nom.)	263	531
Input Amps (Max.)	2.6	5.2
Power Factor	>0.90	

Options:

Description	Suffix
Two conduit/cable glands of like thread installed	S886
Diffused glass lens	S891
Polycarbonate lens.....	S903

Accessories:

Description	Cat. # (Sold Separately)
Bolt-on visor (sold separately).....	DSV1
Bolt-on wire guard (sold separately).....	P61
Floodlight slipfitter (sold separately).....	SFA6*
Slipfitter wall mount adapter (sold separately).....	SWB6*

*Available with PFM25L model only.

Drivers:

PFM Model	25L, 50L
/UNV1	90-305 VAC, 50 / 60 Hz; 127-250 VDC
/UNV34	277-480 VAC Model

Certifications and Compliances:

- UL1598
- UL1598A
- cUL
- NEMA 4X; IP66
- DesignLights Consortium® approved for select models (refer to Ordering Information for details)
- UL approved up to 40°C ambient

Ordering Information:

25L Series†*

50L Series

PFM25LCY/UNV1 76

PFM50LCY/UNV1 76

NOTE: Available in cool color temperature only. For 277-480 VAC option, replace /UNV1 with /UNV34.

†DesignLights Consortium® approved model at 120-277V.

*PFM25L is DLC approved with a 5 year limited warranty. Refer to page 2 of the D-0413 authorized distributor price book for Eaton's Crouse-Hinds standard terms and conditions.

Champ® Pro PFM Series 25L and 50L LED Floodlights

UL/cUL Listed
NEMA 4X
IP66

6L

Safe, reliable heat transfer

The heat sink was designed to perform in high ambient temperatures up to +40°C and as low as -25°C. The thick walls of the castings make for a tough, rugged housing that keeps the internal driver and LED temperatures down, allowing them to perform flawlessly, and protects them from damage. Separated driver and LED housing allows dust to shed from fixture.



High efficiency and lumen output

High efficiency drivers and LEDs provide 100 LPW for reliable low cost operation in industrial environments. Components were chosen to give industry-leading light output from an LED flood. Replaceable drivers and LEDs for ease of maintenance and “no lights out” feature.



Versatile design

Can be used for outdoor or indoor applications, and for a wide range of mounting heights depending on model and light level requirement. Optics were specifically designed to give the familiar and industry-accepted NEMA 7x6 beam light pattern.



Optional equipment (sold separately)

Optional visor offered to control light spill.
Optional wire guard offered to protect lens from damage.
Other options available - consult part numbering guide.

6L

6L Champ® Pro PFM Series 25L and 50L LED Floodlights

UL/cUL Listed
NEMA 4X
IP66

Dimensions:

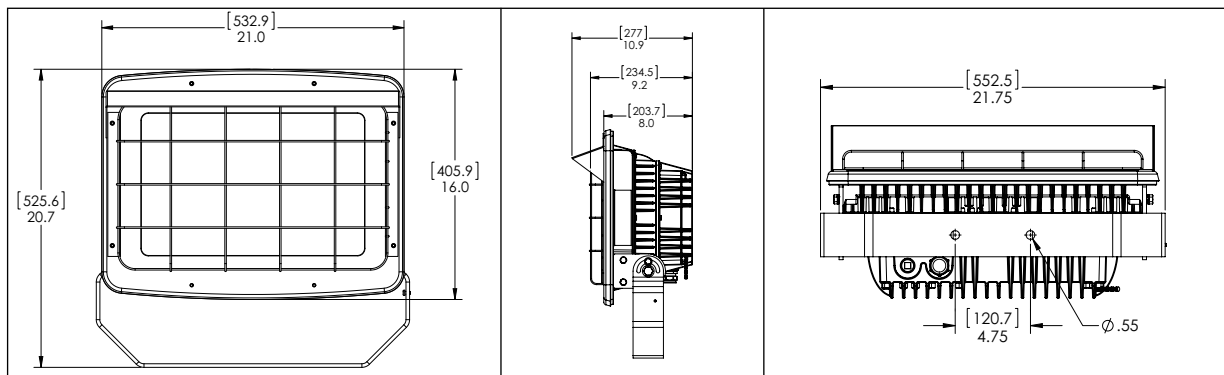

PFM25L Model

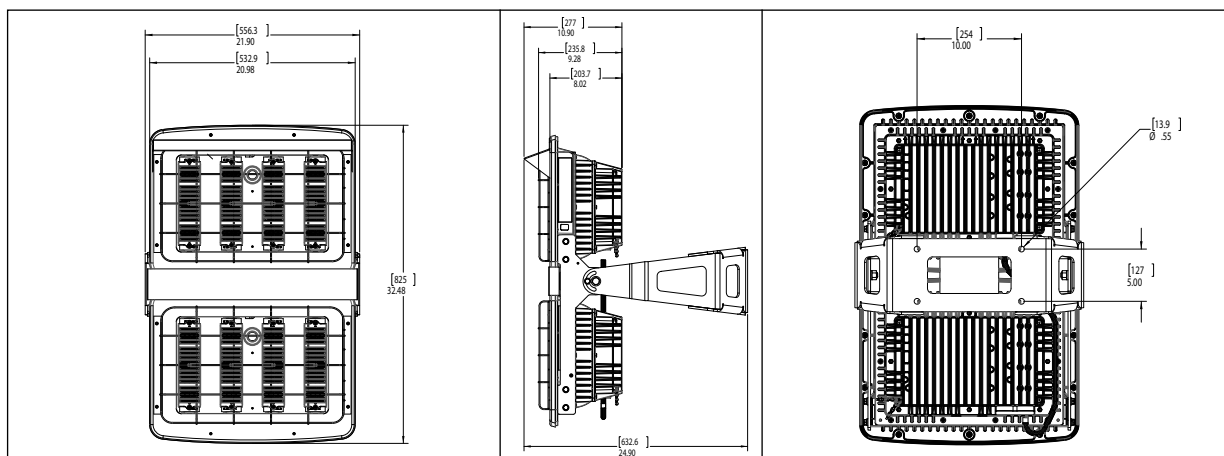

PFM50L Model

6L

Photometric Data:

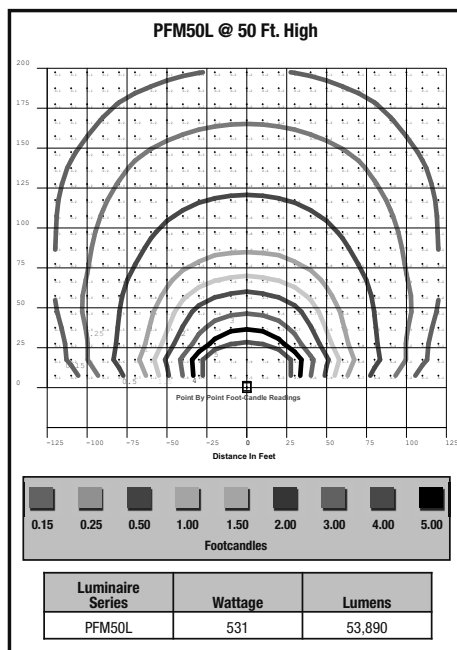
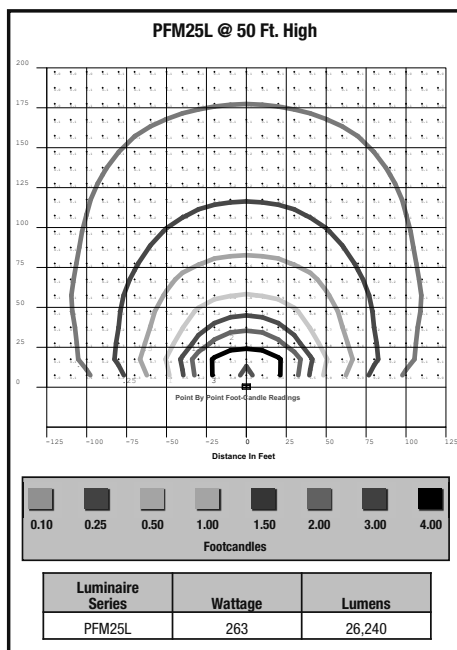

Weights:

PFM Model	Lbs.
PFM25L	52.00
PFM50L	106.00

The Standard for Safety and Reliability

Whenever Eaton's Crouse-Hinds develops a new product, system, or procedure, we focus on one overriding question: Will it lower the total cost of ownership for our customers?

With our new expanded line of Champ® Floodlights, the answer is most definitely, "Yes."

Eaton's Crouse-Hinds utilized more than 100 years of hazardous lighting expertise to design a global floodlight line of unmatched reliability, quality, and performance for your area lighting needs.

- Energy-efficient with optimal light output and beam distribution
- The most accessible ballast assembly in the industry
- Restricted breathing is standard on all floodlights
- Offered with both North American ballast (made to ANSI standard) and European style IEC ballast gear (pending)
- UL marine rated, NEMA Type 4X and IP66



Champ FMV nR Series Floodlight

The Champ FMV nR Series Floodlight offers exceptional indoor and outdoor illumination in industrial areas. Because of its superior corrosion resistance and restricted breathing being standard, the FMV floodlight is the ideal choice for diverse industrial applications that include wet and marine environments.

Differentiations:

- Full frame trunnion mounting bracket
- Restricted breathing standard
- 55°C and 65°C ambient air suitability
- Standard with terminal blocks
- Class I, Division 2/Zone 2
- Removable ballast tray



Champ F2MV Mini-Floodlight

The F2MV is a compact floodlight that consists of a Corro-Free™ epoxy coated copper-free aluminum enclosure with stainless steel external hardware and an impact-resistant glass lens. It is suitable for marine and wet locations and is ideal where space constraints restrict the use of larger floodlights.

Differentiations:

- Small, compact size
- Easy mounting installation—only 2 bolts!
- Powerful light distribution for floodlight and task applications
- Rated for use in 65°C ambient air for hazardous location applications

6L

The Standard for Safety and Reliability



**Champ FMV1000 nR
High Wattage Floodlight**

The Champ FMV1000 nR prides itself on offering restricted breathing and easy-to-wire terminal blocks as standard components. It is NEMA Type 4X and IP56 watertight and due to its heavy-duty vapor-tight, copper-free aluminum housing and stainless steel hardware, it is exclusively designed for harsh and industrial areas requiring broad area lighting. The Champ FMV1000 nR provides a robust design for optimal use in the most corrosive/marine environments.

Differentiations:

- Hazardous location high wattage floodlight for Class I, Division 2, Zone 2
- Restricted breathing standard
- T3 rating in Class I, Zone 2
- 40°C and 55°C ambient air suitability
- Hinged removable door
- Available in 600, 750, 1000, and 1500W systems (1500W for non-hazardous locations only)



**Champ Voyager nR™
Stainless Steel Floodlight**

The Champ Voyager nR Floodlight offers the industry's coolest temperature rating and is the only mogul-base Class I, Division 2 and Zone 2 stainless steel floodlight with restricted breathing as standard construction. It boasts a wide, powerful beam to deliver more light to your process, and with the standard terminal block and removable ballast-component tray, the Champ Voyager is perfect for outdoor, marine, corrosive, and high temperature locations.

Differentiations:

- Housing, door and external parts are all 316 stainless steel
- Restricted breathing standard with T-ratings of T3 and T4
- Pre-wired with terminal blocks for easy wiring
- Hinged door and removable ballast tray

6L

Product Selector Chart					
		F2MV MINI	FMV nR	FMV1000 nR	Voyager nR
Hazardous	Class I, Division 2 Class I, Zone 2	•	•	•	•
Hazardous Restricted Breathing (Ex nR)	NEC/CEC: Class I, Division 2 Class I, Zone 2 IEC Zone 2	•	•	•	•
ATEX Certification with IEC Ballast and Lamp Socket	IEC Zone 2 Ex nR II ATEX		pending		•
Wet		•	•	•	•
Marine		•	•	•	•
NEMA Type 4, 4X		•	•	•	•
NEMA 7x6		•	•	•	•
Corrosion Resistant		•	•	•	•
Confined Areas		•			•
Wattage	High Pressure Sodium Metal Halide	50-150 70-175	150-400 175-400	600, 750, 1000 1000, 1500	150-400 175-400

Champ® FMV nR Floodlights

Cl. I, Div. 2, Groups A, B, C, D
Cl. I, Zone 2, AEx nR II
Cl. II, Div. 1, Groups F, G
(up to 250W)

Marine locations
NEMA Type 4X and IP66
Wet locations

6L

The Champ FMV nR Series Floodlight offers exceptional illumination in industrial areas, both indoors and out. And, it comes standard as a restricted breathing luminaire. The Champ FMV nR Series Floodlight is easily adjusted to aim light where it's needed and is available in a wide variety of energy-saving mogul base HID light sources and wattages including:

- 150–400W High Pressure Sodium
- 175–400W Metal Halide

Applications:

The FMV is made with heavy-duty, die-cast aluminum components and stainless steel hardware. It offers superior corrosion resistance to ensure longer life, which makes the FMV floodlight the ideal choice for a wide variety of industrial applications, including wet and marine environments.

Features and Benefits:

- AEx nR, Ex nR restricted breathing rating is standard—a hazardous location luminaire without additional accessories or options; restricted breathing offers cooler T-numbers for increased hazardous locations suitability
- NEMA 7x6 butterfly beam floodlight pattern—wide, uniform and far reaching to provide excellent efficiency and more light where you need it
- NEMA Type 4X and IP66 construction is designed for use indoors and outdoors in marine and wet locations—with stainless steel external hardware suitable for saltwater and corrosive applications
- Easy wiring—standard terminal block with marked terminals saves time and eliminates wiring errors
- Vapor-tight sealing cable connector—standard
- Will accommodate existing mounting hardware—SFA6 slipfitter for pole and SWB6 wall mount
- Optional metric machining will accept M20 or M25 (must be specified on order)
- 40°C, 55°C and 65°C ambient suitability—addresses high ambients common at industrial facilities
- Low ambient capability to -40°C—perfect for colder climates
- Heavy-duty, die-cast copper-free aluminum enclosure with epoxy coating and stainless steel hardware—provides a robust design with industrial grade construction and corrosion resistance
- Hinged door frame assembly—has captive cover screws for ease of relamping
- Yoke mount design—standard construction provides the greatest mounting flexibility, can be mounted vertically (wall), horizontally (rooftop or floor), or any angle in between

- 3-axis resonance withstand and UL844 vibration compliant—can stand up to the tough jobs
- Precision formed aluminum reflector—superior beam control, distribution and efficiency
- Multi-tap ballasts—offering a choice of 120, 208, 240 and 277V; 220V 50Hz, 240V 50Hz, Tri-Tap (120, 277 and 347), and 480V ballasts are also available
- High light output with a low cost of operation—cost-effectiveness in a high wattage floodlight
- For use with SFA6 Slipfitter Adapter and SWB6 Wall Mount Bracket accessories—further enhances mounting flexibility

Certifications & Compliances:

NEC/CEC (NEC Ballast Gear and Socket):

- Class I, Division 2, Groups A, B, C, D
- Class I, Zone 2, AEx nR II
- Class II, Division 1, Groups F, G (up to 250W)
- Marine locations
- NEMA Type 4X and IP66
- Wet locations

IEC (IEC Ballast Gear and Socket):

- IEC Zone 2, Ex nR II (pending)

UL/cUL Standards:

- 844—Hazardous (Divisions Classified) Locations
- 60079-15
- 1598—Luminaires
- 1598A—Supplemental Requirements for Luminaires for Installation on Marine Vessels

IEC Standards:

- 60079-15

Standard Materials:

- Fixture housing and door frame assembly—die-cast aluminum
- External hardware—stainless steel
- Lens—heat- and impact-resistant tempered glass
- Yoke—aluminum

Standard Finishes:

- Enclosure and yoke—Corro-Free™ epoxy powder coat
- Stainless steel—natural



The only full frame trunnion mount floodlight with a T3 rating and a removable ballast tray assembly.

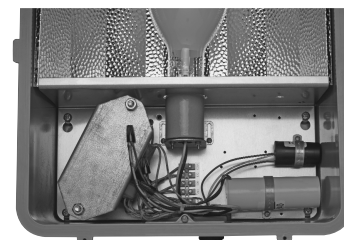

Industry Best for Ease of Installation:

1. Removable ballast tray
2. Prewired to terminal blocks
3. Substantial room for wiring

Ratings (Electrical/Size): Sources/Wattages (Mogul Base Lamps)

- HPS—150, 250, and 400W
- MH—175, 250, and 400W

Voltages

Standard Voltage Ballasts

- Multi-tap (120, 208, 240, and 277V 60Hz)
- Dual-tap (120 and 277V)
- 480V 60Hz
- Tri-tap (120, 277, 347V 60Hz)

Optional Voltage Ballasts

- 220V or 240V 50Hz (for export)
- 220V 60Hz (for export)

Isolated Ballasts

- 208, 240, or 480V (for Canada)

Hub Size

- Standard—3/4" NPT
- Optional—25 mm (M25 x 1.5) or 20 mm (M20 x 1.5)

Crouse-Hinds

by EATON

6L

Ordering Information for Floodlight with NEC Ballast:

Lamp Type	Watts	Yoke Mount 3/4" NPT Hub
High Pressure Sodium	150	FMVSY150/MT 76
	250	FMVSY250/MT 76
	400	FMVSY400/MT 76
Metal Halide	175	FMVMY175/MT 76
	250	FMVMY250/MT 76
	400	FMVMY400/MT 76

Voltage Suffixes†

Voltage (60Hz)	Dual-Tap	Tri-Tap	Multi-Tap	480
Suffix	/DT	/TT	/MT	/480

To complete catalog number, add voltage and options suffix(es).

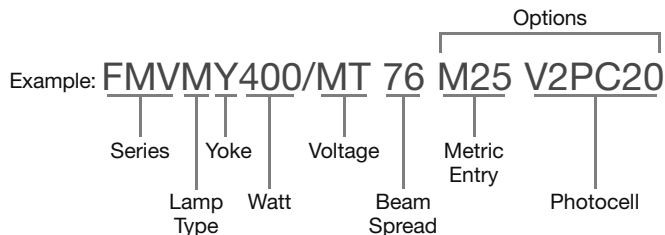

†150W HPS fixtures are furnished with ANSI spec/S55 ballasts for 55V lamps. For 100V lamps, add suffix "CE" after voltage suffix. Example: FMVSY150/MT CE 76.

Photometric Data:

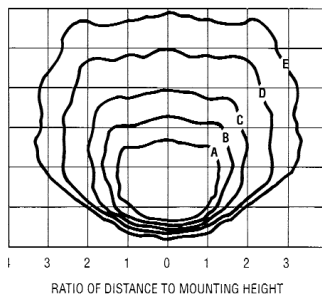

Isofootcandle Chart FMV
400W High Pressure Sodium (HPS)
Catalog Number: FMVSY400-76
Lamp: 400W Clear HPS
Lumen Rating: 50,000
For 150W HPS, multiply footcandles by .32.
For 250W HPS, multiply footcandles by 0.6.
Fixture located at 0°, 0° aiming angle at 45°

(Note: See Figures 1 and 2).

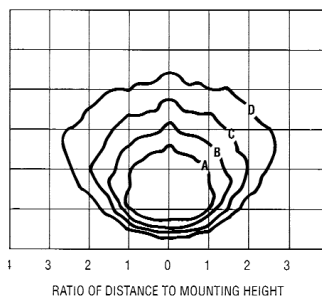

Isofootcandle Chart FMV
400W Metal Halide (MH)
Catalog Number: FMVMY400-76
Lamp: 400W Clear MH
Lumen Rating: 34,000
For 250W MH, multiply footcandles by 0.6.
Fixture located a 0°, 0° aiming angle 45°

(Note: See Figures 1 and 2).

Options:

Description

Instant Restrike and Ballast Guard
Instant restrike—enables a hot HPS lamp to immediately restrike after a momentary loss of arc due to voltage fluctuation or power outage
Ballast guard starter cut out switch—prevents starter pulsing when lamp is cycling or inoperative; prolongs ballast and ignitor life.

Suffix

- 150W LX HPS only..... **TIR**
- Factory assembled with HID lamp installed **FA**
- Fused (not suitable for marine applications)..... **S658**
- 20mm metric thread for conduit opening **M20**
- 25mm metric thread for conduit opening **M25**
- 3/4" NPT hub conduit opening **NPT75**
- Furnished with lamps (not installed) **S714**
- Retention chain **S831**
- Pulse-Start Metal Halide **S828**
- Enclosure machined for 2 conduit/cable entries **S886**

Options for Photocell*:

Description

- Photocell 120V, 50/60Hz installed **Suffix V2PC20**
- Photocell 208-240V, 50/60Hz installed **Suffix V2PC22**
- Photocell 277V, 50/60Hz installed **Suffix V2PC27**

*Photocell for Div. 2 installation only.

Accessories (Order Separately):

Slipfitter Adapter

To be mounted to yoke mount fixture
Fits onto 2" pipe/conduit **SFA6**

Wall Bracket

Use with slipfitter adapter SFA6 for easy wall mounting and increased adjustability..... **SWB6**

Effective Projected Area (EPA):

- For windloading
- For proper pole selection

Aiming Angle	EPA
0°	2.9 FT²
30°	2.5 FT²
45°	2.1 FT²

Footcandle Table:

Mounting Height	Footcandle Values for Isofootcandle Lines				
	A	B	C	D	E
15'	8.0	4.0	2.0	0.80	0.40
20'	4.5	2.3	1.1	0.50	0.23
25'	2.9	1.4	0.7	0.30	0.14
30'	2.0	1.0	0.5	0.20	0.10
35'	1.5	0.7	0.4	0.15	0.07
40'	1.1	0.6	0.3	0.11	0.06

Champ® FMV nR Floodlights

Cl. I, Div. 2, Groups A, B, C, D
Cl. I, Zone 2, AEx nR II

Marine locations
NEMA Type 4X and IP66
Wet locations

6L

Weights and Dimensions:

Net Fixture Weights (Lbs.):

Fixtures	FMVS	FMVM
150W	37	37
175-250W	40	42
400W	44	44

SFA6 (Slipfitter Adapter)—Add 4 lbs., SWB6 (Wall Bracket)—Add 6 lbs.

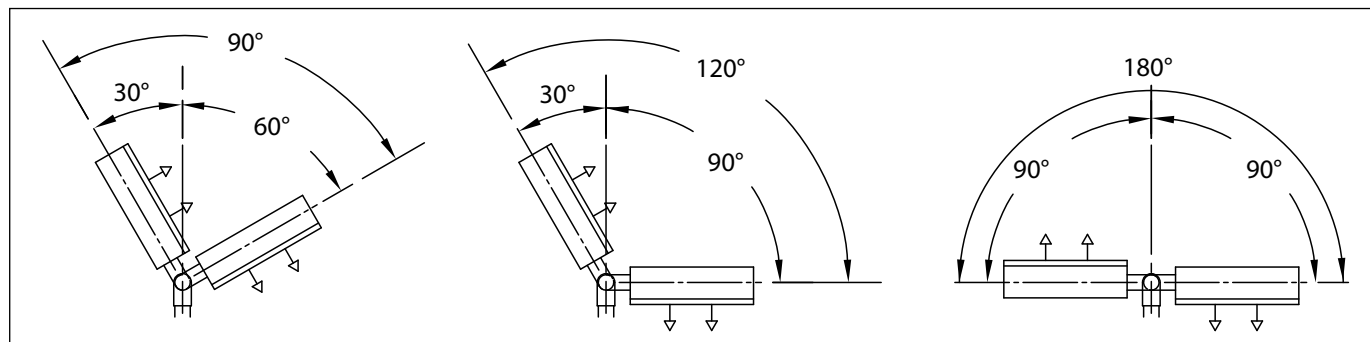
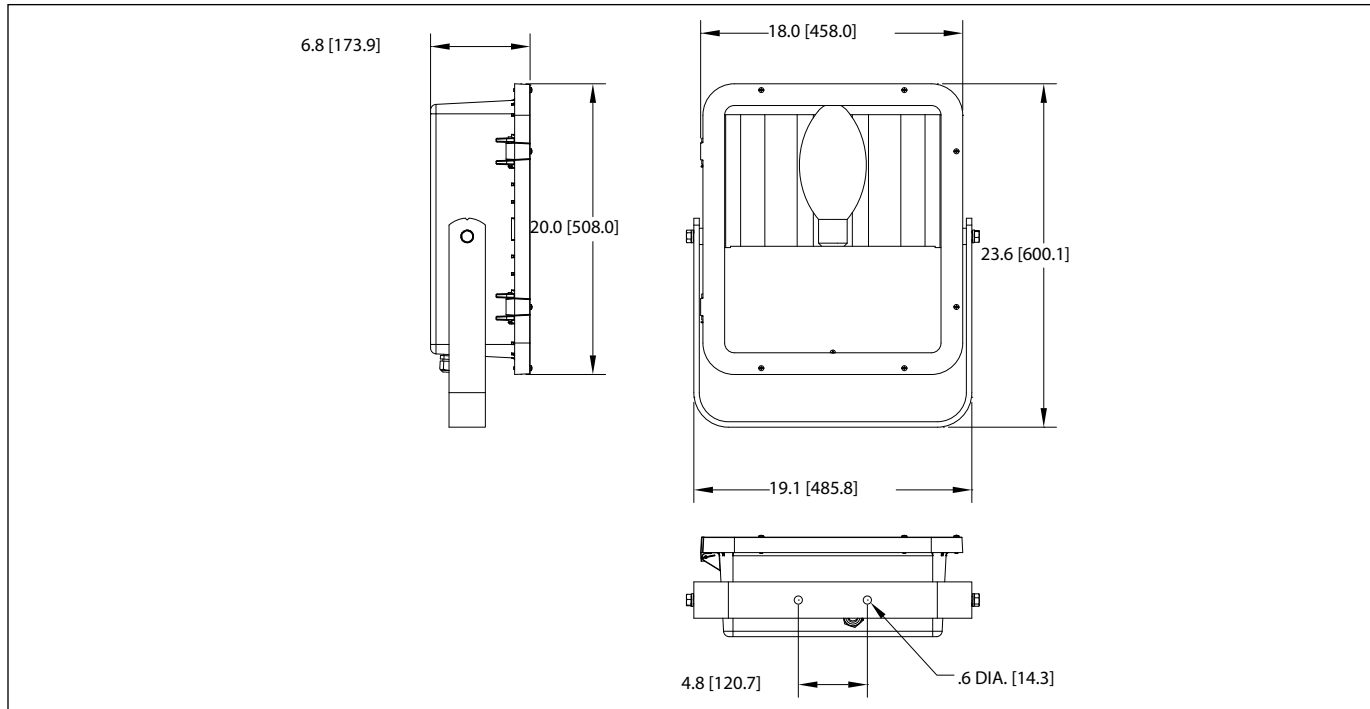

FIGURE 1

FIGURE 2

FIGURE 3

6L

6L

Champ® FMV nR Floodlights

Cl. I, Div. 2, Groups A,B,C,D
Cl. I, Zone 2, AEx nR II

Marine locations
NEMA Type 4X and IP66
Wet locations

Temperature Performance Data:

Catalog Series	Lamp		40°C Ambient			55°C Ambient			65°C Ambient			Fixture Aiming	
			Temperature Code			Temperature Code			Temperature Code			Range	Figure
			Class I, Zone 2	Class I, Div. 2	Supply Wire °C	Class I, Zone 2	Class I, Div. 2	Supply Wire °C	Class I, Zone 2	Class I, Div. 2	Supply Wire °C		
FMVS	High Pressure Sodium	150	T4	325	90	T4	325	90	T3	325	105	90°	1
			T4	325	90	T3	325	105	T3	325	105	120°	2
			T3	325	90	T3	325	105	T3	325	105	180°	3
	250	T4	325	90	T4	325	90	T3	325	105	90°	1	
		T4	325	90	T3	325	105	T3	325	105	120°	2	
		T3	325	90	T3	325	105	T3	325	105	180°	3	
		T3	T1	90	T3	T1	105	-	-	-	90°	1	
		T3	T1	105	T3	T1	125	-	-	-	120°	2	
		T3	T1	105	T3	T1	125	-	-	-	180°	3	
FMVM	Metal Halide	175	T4	325	90	T4	325	90	T3	325	105	90°	1
			T4	325	90	T4	325	105	T3	325	105	120°	2
			T3	350	90	T3	350	125	T3	T1	105	180°	3
		T4	325	90	T4	325	90	T3	325	105	90°	1	
		T4	325	90	T4	325	105	T3	325	105	120°	2	
		T3	350	90	T3	350	125	T3	T1	105	180°	3	
	400**	T3	325	90	T3	325	105	-	-	-	90°	1	
		T3	325	105	T3	325	125	-	-	-	120°	2	
		T3	T1	105	T2	T1	125	-	-	-	180°	3	
	Pulse-Start Metal Halide	175	T4	325	90	T3	325	105	T3	325	105	90°	1
			T4	325	90	T3	325	105	T3	325	105	120°	2
			T3	350	90	T3	T1	105	T3	T1	105	180°	3
		250*	T4	325	90	T3	325	105	T3	325	105	90°	1
			T4	325	90	T3	325	105	T3	325	105	120°	2
			T3	350	90	T3	T1	105	T3	T1	105	180°	3
320**		T3	350	105	T3	350	105	-	-	-	90°	1	
		T3	350	105	T3	T1	125	-	-	-	120°	2	
		T3	T1	105	T3	T1	125	-	-	-	180°	3	

*Suitable for use in 65°C ambient without optional fuses.

**Suitable for use in 55°C ambient without optional fuses.

Lamp Selection (Mogul Base):

Fixture	Watts	Bulb	G.E.	Osram	Philips
	Type				
FMVSY150	150 HPS	ED23 ½ BT25	LU150/55	LU150/55	C150S55
FMVSY250	250 HPS	ED18 ½ or ET18	LU250	LU250	C250S50
FMVSY400	400 HPS	ED37 ½ BT37	LU400	LU400	C400S51
FMVMY175	175 MH	ED28 or BT28	MVR175/U	M175/U	MH175/U
FMVMY250	250 MH	ED28 or BT28	MVR250/U	M250/U	MH250/U
FMVMY400	400 MH	ED37 or BT37	MVR400/U	M400/U	MH400/U

Photometrics are available online.

6L

Champ® FMV1000 nR High Wattage Floodlights

Cl. I, Div. 2, Groups A, B, C, D
Cl. I, Zone 2, AEx nR II, Group IIC

Marine locations
NEMA Type 4X and IP56
Wet locations

6L

The Champ FMV1000 Series High Wattage Floodlight is the best in its class with heavy-duty vapor-tight housing designed exclusively for harsh industrial areas requiring broad area lighting.

The FMV1000 Series Floodlight boasts restricted breathing and easy-to-wire terminal blocks as standard. It is available in the following HID lamp sources and wattages:

- 600, 750, 1000W High Pressure Sodium
- 1000, 1500W Metal Halide

Applications:

The Champ FMV1000 Series is NEMA Type 4X and IP56 watertight, and its heavy-duty welded extruded aluminum housing and stainless steel hardware provide a robust design suitable for the most corrosive/marine environments.

Features and Benefits:

- AEx nR, Ex nR restricted breathing rating is standard—a hazardous location luminaire without additional accessories or options; restricted breathing offers cooler T-numbers for increased hazardous locations suitability
- NEMA 7x6 butterfly beam floodlight pattern—wide, uniform and far reaching to provide excellent efficiency and more light where you need it
- NEMA Type 4X and IP56 construction is designed for use indoors and outdoors in marine and wet locations—with stainless steel external hardware suitable for saltwater and corrosive applications
- Easy wiring—standard terminal block with marked terminals saves time and eliminates wiring errors
- Vapor-tight sealing cable connector—standard
- Standard machining—will accept 3/4 inch NCGB or 3/4 inch Myers™ hub (Myers hub is an option). Optional metric machining will accept M20 or M25 (must be specified on order)
- Low and high ambient capability to -40°C—perfect for colder climates, 50°C workhorse in hot climates
- Heavy-duty, extruded copper-free aluminum enclosure with epoxy coating and stainless steel hardware—provides a robust design with industrial grade construction and corrosion resistance
- Precision formed aluminum reflector—superior beam control, distribution and efficiency
- High light output with a low cost of operation—cost-effectiveness in a high wattage floodlight

Certifications & Compliances:

NEC/CEC (NEC Ballast Gear and Socket):

- Class I, Division 2, Groups A, B, C, D
- Class I, Zone 2, AEx nR II, Group IIC
- Marine locations
- IP56
- Wet locations
- NEMA Type 4X

Standard Materials:

- Housing—extruded aluminum
- External hardware—stainless steel
- Yoke—316 stainless steel
- Lens—heat- and impact-resistant tempered glass
- Gasketing—neoprene



Restricted breathing comes standard with this NEMA Type 4X and IP56 rated floodlight.



Industry Best for Ease of Installation:

1. Removable ballast tray
2. Prewired to terminal blocks
3. Substantial room for wiring

Standard Finishes:

- Aluminum—Corro-Free™ epoxy powder coat
- Stainless steel—natural

Ratings (Electrical/Size):

Sources/Wattages (Mogul Base Lamps)

- HPS—600, 750, and 1000W
- MH—1000W
- MH—1500W non-hazardous location rated

Voltages:

Standard Voltage Ballasts

- Multi-tap (120, 208, 240, and 277V 60Hz)
- 480V 60Hz
- Tri-tap (120, 277, 347V 60Hz)

Optional Voltage Ballasts

- 220V or 240V 50Hz (for export)
- 220V 60Hz (for export)

Isolated Ballasts

- 208, 240, or 480V (for Canada)

Hub Size:

- 3/4" NPT—standard
- M20 or M25—optional
- Dual entry—NPT or metric

6L

6L

Champ® FMV1000 nR High Wattage Floodlights

Cl. I, Div. 2, Groups A, B, C, D
Cl. I, Zone 2, AEx nR II, Group IIC

Marine locations
NEMA Type 4X and IP56
Wet locations

Ordering Information for Floodlight with NEC Ballast:

Lamp Type	Watts	Base Catalog Number*
High Pressure Sodium	600	FMVSY600__ 76
	750	FMVSY750__ 76
	1000	FMVSY1000__ 76
Metal Halide	1000	FMVMY1000__ 76
	1500	FMVMY1500__ 76

*To complete catalog number, add voltage and options suffix(es).

Voltage Suffixes:

Voltage (60Hz)	Dual-Tap	Tri-Tap	Multi-Tap	480
Suffix	/DT	/TT	/MT	/480

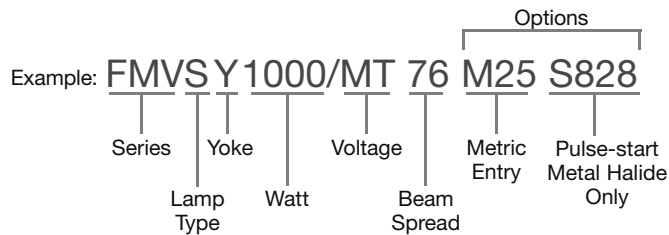

Temperature Performance Data:

Catalog Series	Lamp		40°C Ambient			50°C Ambient			Fixture Aiming		
			Temperature Code			Temperature Code			Range	Figure	
			Class I, Zone 2	Class I, Div. 2	Supply Wire °C	Class I, Zone 2	Class I, Div. 2	Supply Wire °C			
FMVS	High Pressure Sodium	600	T3	T1	90	TS	T1	105	90°	2	
		750	T3	T1	90	T3	T1	105	90°	2	
		1000	T3	T1	90	T3	T1	105	90°	2	
FMVM	Metal Halide	1000	T3	T1	90	T3	T1	105	90°	2	
		Pulse-Start	750	T3	T1	90	-	-	-	75°	1
		Metal	1000	T3	T1	90	T3	T1	105	75°	1
		Halide	1000	T3	T1	90	-	-	-	90°	2

Accessories (Order Separately):

Slipfitter adapter: To be mounted to yoke mount fixture; fits onto 2" pipe/conduit.....	SFA6
Wall bracket: Use with slipfitter adapter SFA6 for easy wall mounting and increased adjustability.....	SWB6
Photocell in DS cover for use with FS/FD box:	
120V, 50/60Hz.....	D2S20
208-277, 50/60Hz.....	D2S208 277

Options:

Description	Suffix
20mm metric thread for conduit opening.....	M20
25mm metric thread for conduit opening.....	M25
3/4" NPT hub conduit opening.....	NPT75
Pulse-start metal halide only.....	S828
Retention chain.....	S831
Enclosure machined for 2 conduit/cable entries.....	S886
Factory assembled, lamp installed in lampholder.....	FA

Weights and Dimensions:

Net Fixture Weights (Lbs.):

Fixture Series	Weight
FMVSY600	78
FMVSY750	76
FMVSY1000	83
FMVMY1000	76
FMVMY1500	84

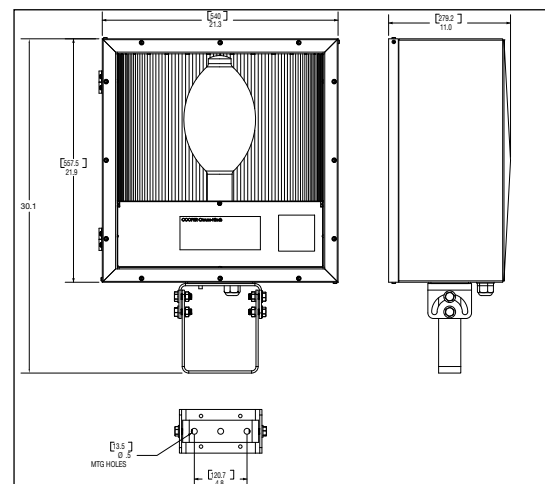

Crouse-Hinds
by **E.T.N**

Champ® FMV1000 nR High Wattage Floodlights

Cl. I, Div. 2, Groups A, B, C, D
Cl. I, Zone 2, AEx nR II, Group IIC

Marine locations
NEMA Type 4X and IP56
Wet locations

6L

Effective Projected Area (EPA):

- For windloading
- For proper pole selection

Aiming Angle	EPA
0°	3.5 FT ²
30°	3.6 FT ²
60°	2.9 FT ²

Photometric Data:

ISO Footcandle Chart FMV
1000W High Pressure Sodium (HPS)
Catalog Number: FMVSY1000-76
Lamp: 1000W Clear HPS
Lumen Rating: 140,000
Fixture located at 0°, 0° aiming angle at 45°
(Note: See Figures 1 and 2).

ISO Footcandle Chart FMV
1000W Metal Halide (MH)
Catalog Number: FMVMY1000-76
Lamp: 1000W Clear MH
Lumen Rating: 110,000
For 1500W MH, multiply footcandles by 1.4
Fixture located at 0°, 0° aiming angle at 45°
(Note: See Figures 1 and 2).

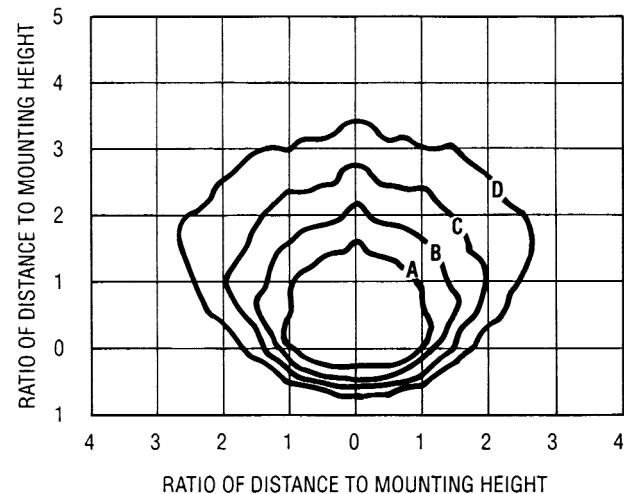
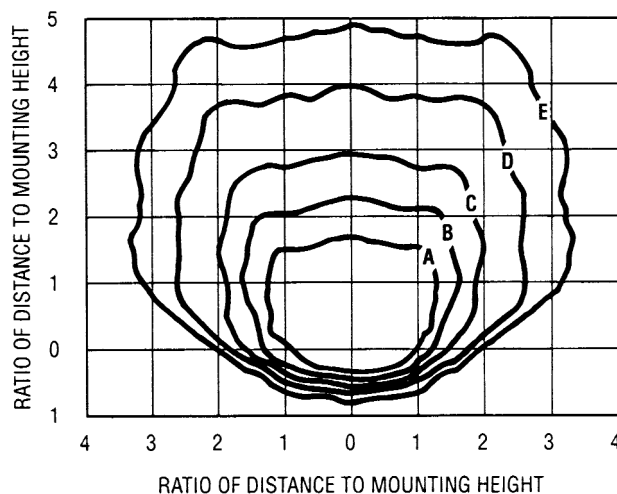

Footcandle Table for FMVS1000W:

Mounting Height	Footcandle Values for Isofootcandle Lines				
	A	B	C	D	E
20'	12.6	6.4	3.1	1.4	0.64
25'	8.1	3.9	2.0	0.8	0.4
30'	5.6	2.8	1.4	0.6	0.28
35'	4.2	2.1	1.0	0.42	0.2
40'	3.1	1.6	0.8	0.32	0.17

Lamp Selection (Mogul Base):

Fixture	Watts	Type	Bulb	G.E.	Osram	Philips
FMVSY600	600	HPS	T15	LU600/T	—	C600S106
FMVSY750	750	HPS	ED37	LU750	—	—
FMVSY1000	1000	HPS	E25	LU1000	—	C1000S52/ED37
FMVMY750	750	MH	ED37	MVR750/VBU/PA	—	—
FMVMY1000	1000	MH	BT56	MVR1000/U	—	MH1000/U
FMVMY1500	1500	MH	BT56	MVR1500/U/SPORTS	—	MH1500/U

6L

6L

Champ® Voyager nR™ Stainless Steel Floodlight

Cl. I, Div. 2, Groups A, B, C, D
Cl. I, Zone 2, AEx nR II, Group IIC
IEC Zone 2, Ex nR II ATEX

Marine locations
Wet locations

Eaton's Crouse-Hinds Champ® Voyager nR™ Stainless Steel Floodlight offers the industry's coolest temperature ratings—so it can operate below the ignition temperature of vapors and gases in your classified area. The Champ Voyager nR Floodlight boasts a wide, powerful beam to deliver more light to your process or pathway. Standard terminal blocks and a removable ballast component tray bring you the best combination of easy wiring and simple maintenance in one rugged package.

Applications:

This unique combination of features makes the Champ Voyager nR Floodlight ideal for outdoor, marine, corrosive, and high temperature locations.

And because the Champ Voyager nR Floodlight meets international standards, you can install it anywhere in the world.

Features and Benefits:

- AEx nR, Ex nR restricted breathing rating is standard—a hazardous location luminaire with excellent T3 and T4 ratings without additional accessories or options
- NEMA 7x6 "butterfly beam" floodlight pattern—wide, uniform and far reaching to reduce the number of luminaires you need, providing excellent luminaire efficiency—more light where you need it
- Easy wiring—standard terminal block with marked terminals saves time and eliminates wiring errors
- Removable ballast component tray—for capacitor, igniter and terminal block to simplify maintenance and save money
- Housing, hinges, door frame and mounting yoke are all 316 stainless steel for marine and wet locations—robust construction suitable for saltwater and corrosive applications

Certifications & Compliances:

NEC/CEC (NEC Ballast Gear and Socket):

- Class I, Division 2, Groups A, B, C, D
- Class I, Zone 2, AEx nR II, Group IIC
- NEMA Type 4X and IP66

IEC (IEC Ballast Gear and Socket):

- IEC Zone 2, Ex nR II ATEX

UL/cUL Standards:

- 844—Hazardous (Divisions Classified) Locations
- 1598—Luminaires Marine Locations
- 1598A—Supplemental Requirements for Luminaires for Installation on Marine Vessels

Standard Materials:

- Enclosure (housing and lens frame)—316 stainless steel
- Lens—heat- and impact-resistant tempered glass
- Gaskets—silicone rubber
- Yoke and yoke bracket—316 stainless steel
- Reflector—formed specular (dimpled glossy surface) aluminum
- Cable gland cord grip and locknut—polyamide 6, neoprene bushing

Standard Finishes:

- 316 stainless steel—natural

Photometrics are available online.



Now available with IEC gear and certified to the IECEx/ATEX Directive. The only mogul base Class I, Division 2 and Zone 2 stainless steel floodlight with restricted breathing (vapor-tight design) as standard construction.

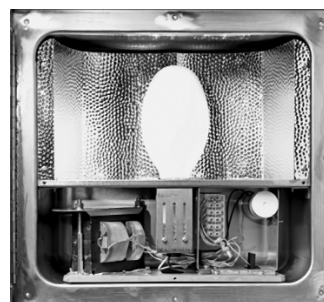

Industry Best for Ease of Installation:

1. Removable ballast tray
2. Prewired to terminal blocks
3. Substantial room for wiring

Ratings (Electrical/Size):

Sources/Wattages (Mogul Base Lamps)

- High Pressure Sodium (HPS) 150, 250, and 400W
- Metal Halide (MH) 175, 250, and 400W

Voltages:

Standard Voltage Ballasts

- Multi-tap (120, 208, 240, and 277V 60Hz)
- 480V, 60Hz
- Tri-tap (120, 277, 347V 60Hz)

Optional Voltage Ballasts (for export)

- 220V or 240V, 50Hz
- 220V, 60Hz

Isolated Ballasts

- 208, 240, or 480V (for Canada)

Hub Size:

- Standard: 3/4" NPT with a 3/4" gland sealing connector

6L

Champ® Voyager nR™ Stainless Steel Floodlight

Cl. I, Div. 2, Groups A, B, C, D
Cl. I, Zone 2, AEx nR II, Group IIC
IEC Zone 2, Ex nR II ATEX

Marine locations
Wet locations

6L

Ordering Information for Floodlight with IEC Ballast:

Lamp Type	IEC Ref.	Watts	Catalog Number*
HPS	HSE/HST	150	NSSFMVSY150/220
		250	NSSFMVSY250/220
		400	NSSFMVSY400/220
MH	HIE	150	NSSFMVMY150/220
		250	NSSFMVMY250/220
		400	NSSFMVMY400/220

*Uses IEC lamp socket E40.

NSSFMV Floodlights are designed with IEC ballast gear and lamp socket, providing certification to the IEC Ex ATEX Directive.

Ordering Information for Floodlight with NEC Ballast:

Lamp Type	Watts	Catalog Number*
High	150	SSFMVSY150 76
Pressure	250	SSFMVSY250 76
Sodium	400	SSFMVSY400 76
Metal	175	SSFMVMY175 76
Halide	250	SSFMVMY250 76
	400	SSFMVMY400 76

Voltage Suffixes:

Voltage	Suffix	Voltage	Suffix
Tri-Tap (120, 277, 347V, 60Hz)	/TT	220 50Hz	/220 50
Multi-Tap 120, 208, 240, 277V, 60Hz)	/MT	220 60Hz	/220
480V, 60Hz	/480	240 50Hz	/240 50
240V, 60Hz	/MV	240 60Hz	/240 60

*To complete catalog number, add voltage and options suffix(es)
Example: SSFMVSY150/MT 76.

Temperature Performance Data:

Catalog Series	Lamp		40°C Ambient			55°C Ambient			Fixture Aiming	
			Temperature Code			Temperature Code				
	Type	Watts	Class I, Zone 2	Class I, Div. 2	Supply Wire °C	Class I, Zone 2	Class I, Div. 2	Supply Wire °C	Range	Figure
SSFMVS	High	150**	T4	T2B	90	T4	T2B	105	120°	2
	Pressure	250**	T4	350	90	T3	350	105	90°	1
	Sodium	400	T3	T1	90	-	-	-	90°	1
SSFMVM	Metal Halide	175**	T3	T2	90	T3	T2	105	120°	2
		250**	T3	325	90	T3	325	105	90°	1
		400	T3	325	105	-	-	-	90°	1

**Suitable for use in 55°C ambient without optional fuses.
For U.S. market, use MH Pulse Start option.

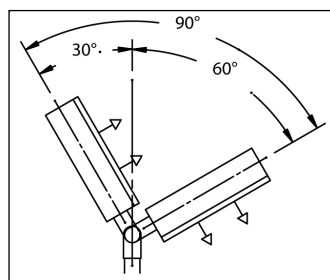

FIGURE 1

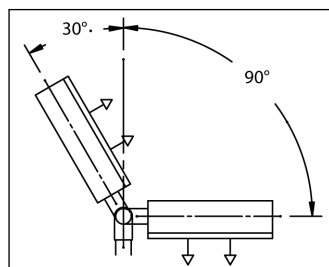

FIGURE 2

Accessories (Order Separately):

Stainless steel slipfitter adapter.....	SFA6 SS
Stainless steel wall mount bracket.....	SWB6 SS
Standard slipfitter adapter (cast aluminum).....	SFA6
Standard wall mount bracket (cast aluminum).....	SWB6
Photocell in DS cover for use with FS/FD box: 120V, 50/60Hz.....	D2S20
208-277V, 50/60Hz.....	D2S208 277

Photometrics are available online.

Crouse-Hinds
by **E.T.N**

6L Champ® Voyager nR™ Stainless Steel Floodlight

Cl. I, Div. 2, Groups A, B, C, D
Cl. I, Zone 2, AEx nR II, Group IIC
IEC Zone 2, Ex nR II ATEX

Marine locations
Wet locations

Effective Projected Area (EPA):

- For windloading
- For proper pole selection

Aiming Angle	EPA
0°	2.15 FT ²
30°	1.86 FT ²
60°	1.07 FT ²

Weights and Dimensions:

Net Fixture Weights (Lbs.)

Luminaire	HPS	MH
150W	39	39
175W	39	39
250W	43	41
400W	45	43

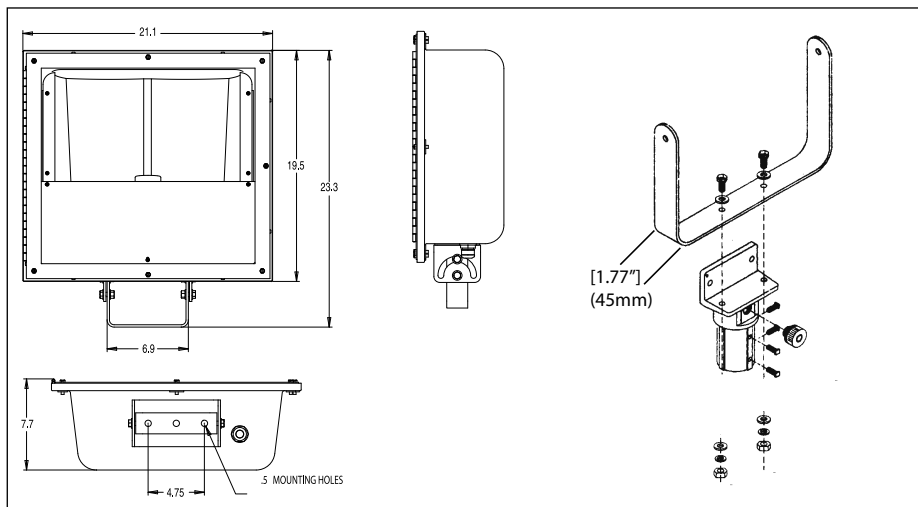

6L

Options:

Description

Instant Restrike and Ballast Guard

Instant Restrike—enables a hot HPS lamp to immediately restrike after a momentary loss of arc due to voltage fluctuation or power outage

Ballast guard starter cut out switch—prevents starter pulsing when lamp is cycling or inoperative; prolongs ballast and ignitor life.....

- 150W LX HPS only

Factory assembled with HID lamp installed.....

Fused (not suitable for marine applications).....

20mm metric thread for conduit opening.....

25mm metric thread for conduit opening.....

3/4" NPT hub conduit opening.....

Furnished with lamps (not installed).....

Pulse-start metal halide only.....

Enclosure machined for 2 conduit/cable entries.....

Yoke mount and slipfitter.....

Suffix

TIR

FA

S658

M20

M25

NPT75

S714

S828

S886

SFA6

Photometrics are available online.

Champ® Voyager nR™ Stainless Steel Floodlight

Cl. I, Div. 2, Groups A, B, C, D
Cl. I, Zone 2, AEx nR II, Group IIC
IEC Zone 2, Ex nR II ATEX

Marine locations
Wet locations

6L

Photometric Data:

MH Wide Beam Reflector

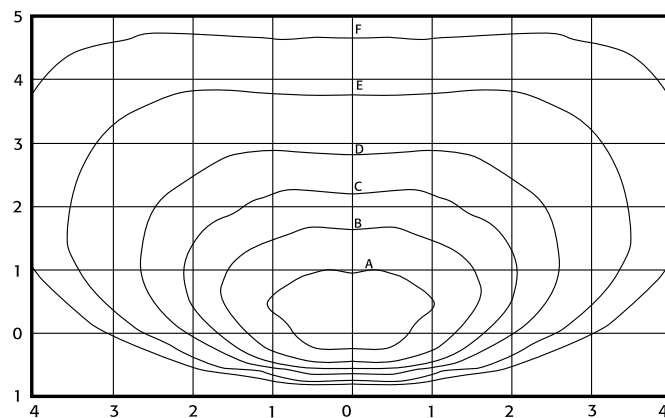

LUMINAIRE IS LOCATED AT 0,0 AND AIMED 45 DEGREES DOWN FROM HORIZONTAL

ISOFOOTCANDLE CHART

400W Metal Halide (MH)

Catalog Number: SSFMVMY400/MT

Lamp: 400W Clear MH

Lumen Rating: 34,000

Luminaire located at 0, 0° aiming angle at 45° down from horizontal

For 175W MH, multiply footcandles by 0.42.

For 250W HPS, multiply footcandles by 0.65.

HPS Wide Beam Reflector

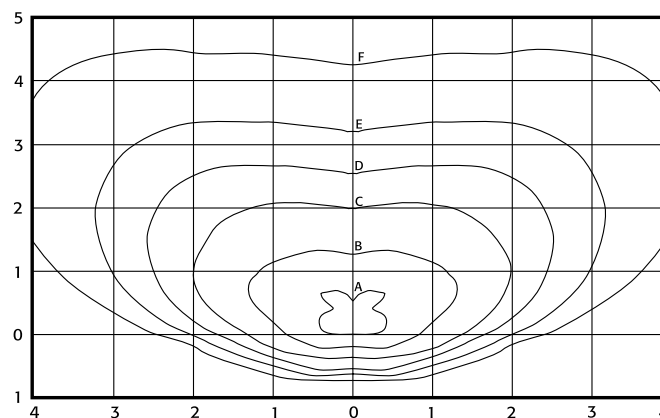

LUMINAIRE IS LOCATED AT 0,0 AND AIMED 45 DEGREES DOWN FROM HORIZONTAL

ISOFOOTCANDLE CHART

400W High Pressure Sodium (HPS)

Catalog Number: SSFMVSY400/MT

Lamp: 400W Clear HPS

Lumen Rating: 50,000

Luminaire located at 0, 0° aiming angle at 45° down from horizontal

For 150W HPS, multiply footcandles by 0.32.

For 250W HPS, multiply footcandles by 0.57.

Mounting Height	Footcandle Values for Isofootcandle Lines					
	A	B	C	D	E	F
10'	20.000	39.000	4.000	2.000	0.800	0.400
15'	8.889	3.555	1.778	0.889	0.356	0.178
20'	5.000	2.000	1.000	0.500	0.200	0.100
25'	3.200	1.280	0.640	0.320	0.128	0.064
30'	2.222	0.889	0.444	0.222	0.089	0.044
35'	1.633	0.653	0.327	0.163	0.065	0.033
40'	1.250	0.500	0.250	0.125	0.050	0.025

Mounting Height	Footcandle Values for Isofootcandle Lines					
	A	B	C	D	E	F
10'	40.000	20.000	8.000	4.000	2.000	0.800
15'	17.778	8.889	3.555	1.778	0.889	0.356
20'	10.000	5.000	2.000	1.000	0.500	0.200
25'	6.400	3.200	1.280	0.640	0.320	0.128
30'	4.444	2.222	0.889	0.444	0.222	0.089
35'	3.265	1.633	0.653	0.327	0.163	0.065
40'	2.500	1.250	0.500	0.250	0.125	0.050

Photometrics are available online.

6L

6L Champ® FMV LED Series Floodlight Fixtures

Cl. I, Div. 2, Groups A, B, C, D
 Cl. I, Zone 2
 Cl. II, Groups E, F, G
 Cl. III

UL Listed & CSA Certified
 IECEx / ATEX
 Simultaneous Presence
 Wet Location, Type 4X, IP66

The Champ FMV LED Family

FMV LED Series Floodlights are designed to provide full-spectrum, crisp, white light. Five versions of the Champ FMV LED are available, providing ideal solutions for a wide range of applications.

FMV Model	Equivalent MH HID Lamp	Energy Savings
FMV 5L	100W-150W	Up to 62%!
FMV 7L	150W-175W	
FMV 9L	175W-250W	
FMV 11L	250W-400W	
FMV 13L	400W	

Applications:

- Five lumen outputs allow for installation in numerous mounting heights
- Locations requiring continuous and consistent light levels in extreme ambient temperatures
- Areas requiring frequent on-and-off of lights
- Where flammable vapors, gases, ignitable dusts, fibers or flyings are present; indoors or outdoors
- Where extremely corrosive, wet, dusty, hot and/or cold conditions exist
- Type 4X, marine, wet locations, and hose-down environments
- Indoor and outdoor area lighting in plants, buildings, and parking areas
- Manufacturing plants; heavy industrial, chemical, petrochemical or pharmaceutical facilities; platforms; loading docks; outdoor mounted general area lighting

Drivers:

Model	5L - 13L
Standard	90-305 VAC, 50 / 60 Hz; 108-250 VDC
Option 1	347 VAC Model
Option 2	480 VAC Model

Champ FMV LED Benefits:

Enhance safety and productivity

- Instant illumination and restrike
- Better visibility with crisp, white light
- Minimum T4 temperature rating – safely operate in the most hazardous environments and any non-hazardous location
- Cold temperature operation / no warm-up required

Electrical Ratings:

	FMV 5L	FMV 7L	FMV 9L	FMV 11L	FMV 13L
Voltage Range, VAC	100-277V 50 / 60 Hz 347 / 480V 60 Hz				
Voltage Range, VDC	108-250	108-250	108-250	108-250	108-250
Input Power (Nom.)	64	89	121	149	179
Input Amps (Max.)	0.550	0.800	1.083	1.608	1.608
Power Factor	>0.85	>0.85	>0.85	>0.85	>0.85

- “No lights out” feature – if a single LED fails, others will remain lit from other drivers – minimum 50% output maintained
- Terminals – 3 x 6 sq. mm. for IEC version

Reduce operation and maintenance costs

- Easy installation - compact modular fixture attaches onto existing SFA6 and SWB6
- Energy-efficient technology – use up to 1/2 the power of standard HID luminaires
- Provides up to 60,000 hours rated life – eliminates need for frequent lamp replacement
- Contains no mercury or other hazardous substances

Reliable performance in any environment

- Shock- and vibration-resistant solid-state luminaires have no filaments or glass components that could break – greatly reduces the risk of premature failure
- Operating ambient -40°C to 55°C
- Dark sky friendly with optional visor

Certifications and Compliances:

- DesignLights Consortium® approved for select models (refer to Ordering Information for details)

NEC and CEC

- Class I, Division 2, Groups A, B, C, D
- Class I, Zone 2
- Class II, Groups E, F, G
- Class III
- Simultaneous Presence
- Wet Locations, Type 4X, IP66

UL Standards

- UL844
- UL1598 Luminaires, UL1598A Marine

CSA Standard

- CSA C22.2 No. 137

IECEx/ATEX

- IECEx UL 11.0054X
- Ex nA nR IIC T4 Gc Tamb -30°C to +55°C
- Ex nA nR IIC T5 Gc Tamb -30°C to +40°C
- Ex tc IIIC T68°C Dc IP66 Tamb -30°C to 40°C
- DEMKO 12 ATEX 115535X
- Ex II 3 G Ex nA nR IIC T4 Gc Tamb -30°C to +55°C
- Ex II 3 G Ex nA nR IIC T5 Gc Tamb -30°C to +40°C
- Ex II 3 D Ex tc IIIC T68°C Dc IP66 Tamb -30°C to +40°C
- CEPEL Ex-1956/10



Standard Materials:

- Housing – copper-free aluminum with Corro-free™ epoxy powder coat
- Lens – shatter-resistant glass
- Gaskets – silicone
- External hardware – stainless steel
- Factory-sealed, no external seals required

LED System:

- High brightness light emitting diode (LED) arrays
- Color temperature: 3000K (CRI 82) and 5600K (CRI 65) options available
- Advanced heat sink design ensures LED does not exceed manufacturer's temperature ratings across all specified ambient conditions
- LM-80 reports available upon request

Options:

Description	Suffix
Fused (only applies to UNV1 model, not available for 347V or 480V; NOT marine or cUL Listed) (NEC version only)	S658
Two conduit/cable glands of like thread installed	S886

Accessories (Order Separately):

Description	Cat. No.
Bolt-on visor (sold separately)	DSV1
Bolt-on wire guard (sold separately)	P61
Floodlight slipfitter (sold separately)	SFA6
Slipfitter wall mount adapter (sold separately)	SWB6

Crouse-Hinds
 by **E.T.N**

Champ® FMV LED Series Floodlight Fixtures

Cl. I, Div. 2, Groups A, B, C, D
Cl. I, Zone 2
Cl. II, Groups E, F, G
Cl. III

UL Listed & CSA Certified
IECEX / ATEX
Simultaneous Presence
Wet Location, Type 4X, IP66

6L

Safe, reliable heat transfer

The heat sink was designed to perform in high ambient temperatures up to +55°C and as low as -40°C. The thick walls of the castings make for a tough, rugged housing that keeps the internal driver and LED temperatures down, allowing them to perform flawlessly, and protects them from damage. Separated driver and LED housing allows dust to shed from fixture.



Installation and replacement made simple

The full-frame yoke was designed to utilize the SFA6 slipfitter and SWB6 wall mount bracket (sold separately), making it ideal for retrofit or new installations. The modular design of the FMV LED allows for easy driver or LED replacement, and allows for the addition of the optional visor or guard in the field. Single cable gland provided with a second plugged cable entry, if an additional cable gland is needed.



High efficiency and lumen output

High efficiency drivers and LED arrays provide reliable low cost operation in **harsh and hazardous environments**. Components were chosen to give industry-leading light output from an LED flood. Replaceable drivers and LEDs for ease of maintenance and “no lights out” feature.



Versatile design

Suitable for hazardous location use in **gas or dust areas**. Can be used for outdoor or indoor applications, and for a wide range of mounting heights depending on model and light level requirement. Optics were specifically designed to give the familiar and industry-accepted butterfly beam light pattern.

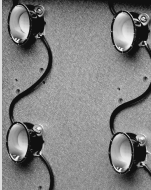

Optional equipment

Cool (C) and Warm (W) white color temperatures available. Optional visor offered (sold separately) to control light spill. Optional wire guard offered (sold separately) to protect lens from damage. Other options available - consult part numbering guide.

6L

6L Champ® FMV LED Series Floodlight Fixtures

Cl. I, Div. 2, Groups A, B, C, D
 Cl. I, Zone 2
 Cl. II, Groups E, F, G
 Cl. III

UL Listed & CSA Certified
 IECEx / ATEX
 Simultaneous Presence
 Wet Location, Type 4X, IP66

Catalog Numbering System:

SERIES	LIGHT SOURCE	COLOR	MOUNT	VOLTAGE	OPTICAL DISTRIBUTION	SUFFIXES
FMV	9L	C	Y	/UNV1	76	S658

SERIES

FMV NEC version with Class/Division ratings

NFMV IEC version with Class/Zone ratings

LIGHT SOURCE / INTENSITY

5L 100W - 150W equivalent

7L 150W - 175W equivalent

9L 175W - 250W equivalent

11L 250W - 400W equivalent

13L 400W equivalent

COLOR TEMPERATURE

C 5600K (cool white)

W 3000K (warm white)

MOUNT

Y Yoke

VOLTAGE

/UNV1 100 VAC to 277 VAC 50/60 Hz, 108 VDC to 250 VDC

/120 120 VAC 50/60 Hz**

/347 347 VAC 60 Hz

/480 480 VAC 60 Hz

OPTICAL DISTRIBUTION

76 Floodlight pattern optics included

SUFFIXES

M20 20mm metric threads for conduit opening (NFMV only)*

M25 25mm metric threads for conduit opening (NFMV only)*

S658 Fused; for UNV1 only; not for marine or cUL

S886 Two conduit/cable glands of like thread installed



79

ADDITIONAL ITEMS (SOLD SEPARATELY)

DSV1 DSV dark sky visor

P61 Wire guard factory installed

SFA6 Floodlight slipfitter

SWB6 Slipfitter wall mount adapter

*Required for NFMV. Please specify conduit entry.

**5 year limited warranty. Refer to page 2 of the D-0413 authorized distributor price book for Eaton's Crouse-Hinds standard Terms and Conditions.

DesignLights Consortium® approved models. Cool white only.

Dimensions:

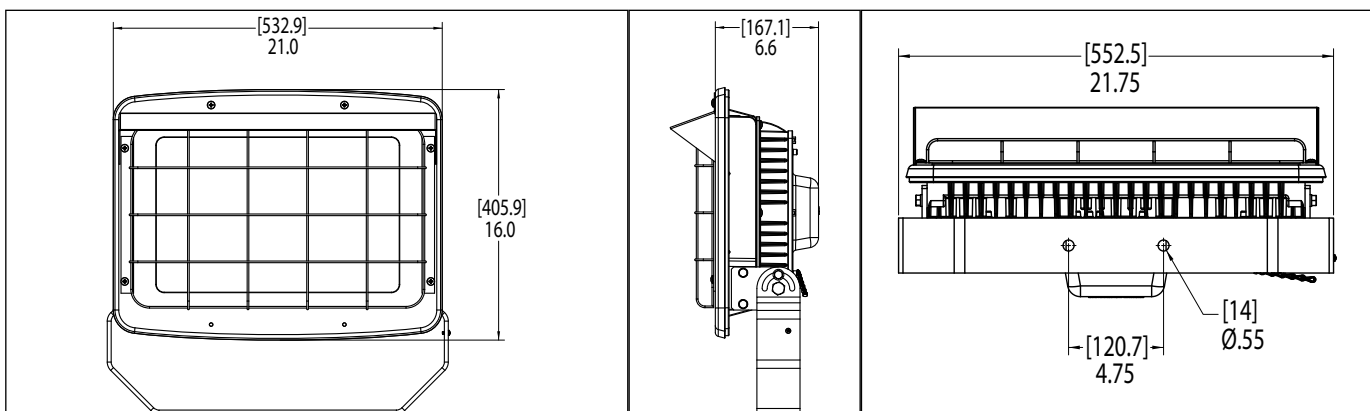

Champ® FMV LED Series Floodlight Fixtures

Cl. I, Div. 2, Groups A, B, C, D
 Cl. I, Zone 2
 Cl. II, Groups E, F, G
 Cl. III

UL Listed & CSA Certified
 IECEx / ATEX
 Simultaneous Presence
 Wet Location, Type 4X, IP66

6L

Photometric Data:

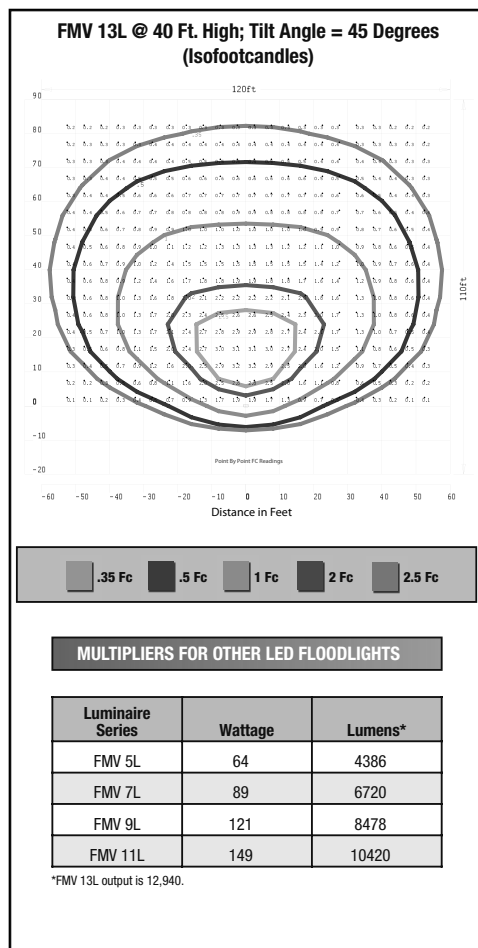

Weights:

Model	Lbs.	Kg.
5L	39.11	17.74
7L	39.16	17.76
9L	39.73	18.02
11L	40.35	18.30
13L	40.35	18.30

Ambient Temperature:

	Max. Temp. °C	Cl. I, Div. 2	Cl. I, Zone 2	Simu. Presence Div. 1 and Div. 2	Cl. II, Div. 1	Cl. III
FMV 5L	40	T3C	T5	T3A	T5	T5
	55	T3C	T4	-	-	-
FMV 7L	40	T3C	T5	T3A	T5	T5
	55	T3C	T4	-	-	-
FMV 9L	40	T3C	T5	T3A	T5	T5
	55	T3C	T4	-	-	-
FMV 11L	40	T3C	T5	T3A	T5	T5
	55	T3C	T4	-	-	-
FMV 13L	40	T3C	T5	T3A	T5	T5
	55	T3C	T4	-	-	-

6L

F2MV is a compact floodlight consisting of a Corro-Free™ epoxy coated copper-free aluminum enclosure, with stainless steel external hardware and impact-resistant glass. It is available for use with the following energy-saving mogul base HID lamp types and wattages:

- High Pressure Sodium (HPS)—50, 70, 100, and 150W
- Metal Halide (MH)—70, 100, and 175W

Applications:

Available in a variety of voltage ratings, this compact floodlight is suitable for marine and wet locations.

Features and Benefits:

- Small, compact size—easy to install and maintain
- 40°C, 55°C, and 65°C ambient suitability—addresses high ambients common in industrial facilities
- Low ambient capability to -40°C—perfect for colder climates
- Heavy-duty, copper-free aluminum enclosure with epoxy coating and stainless steel hardware—provides a robust design with industrial grade construction and corrosion resistance
- Continuous silicone gasketing—ensures wet and marine locations integrity
- Stainless steel tether chain and captive cover screws—secure cover to housing ensures ease of maintenance
- Trunnion (yoke) mount design—standard construction provides the greatest mounting flexibility, can be mounted vertically (wall), horizontally (rooftop or floor), or any angle in between
- Requires only two bolts to mount—simplifies installation
- Heat- and impact-resistant tempered glass lens—provides exceptional stability
- Shock-absorbing mogul base lamp socket—cushions lamp, improves lamp life in harsh environments
- 3-axis resonance withstand and UL844 vibration compliant—stands up to the tough jobs
- Precision formed aluminum reflector—superior beam control, distribution and efficiency
- NEMA 7x6 floodlight pattern with lamp orientation base down—the ideal light distribution for industrial applications
- Multi-tap ballasts—offering a choice of 120, 208, 240, and 277V; 220V, 50Hz; 240V 50Hz; Tri-Tap (120, 277, and 347) and 480V ballasts are also available
- High light output with a low cost of operation—a cost-effective, high wattage floodlight
- For use with SFA6 slipfitter adapter and SWB6 wall mount bracket accessories—further enhances mounting flexibility
- Restricted breathing compliance—cooler T-numbers for increased hazardous locations suitability

Standard Materials:

- Enclosure (housing and lens cover)—copper-free aluminum
- Cover chain and external hardware—stainless steel
- Lens—heat- and impact-resistant glass
- Gaskets—silicone rubber
- Yoke—copper-free aluminum
- Reflector—diffused aluminum lighting sheet

Standard Finishes:

- Enclosure and yoke—Corro-Free™ epoxy powder coat
- Stainless steel—natural



Certifications & Compliances:

NEC/CEC:

- Class I, Division 2, Groups A, B, C, D
- Marine locations
- NEMA Type 4X
- Wet locations

IEC/NEC/CEC:

- Class I, Zone 2, Group IIC
- With suffix—S826 and S826TB—restricted breathing (Ex nR) option
- Class I, Zone 2
- Class I, Division 2

UL Standards:

- 844—Hazardous (Divisions Classified) Locations
- 2279—Hazardous (Zones Classified) Locations
- 1572—Ordinary and Wet Locations, Marine Outside Type

CSA Standards:

- C22.2 No. 137
- CAN/CSA-E79 Series

IEC Standards:

- 60079-15

Ratings (Electrical/Size):

Sources/Wattages (Mogul Base Lamps)

- HPS—50, 70, 100, and 150W
- MH—70, 100, and 175W

Voltages:

Standard Voltage Ballasts

- Multi-tap (120, 208, 240, and 277V 60Hz)
- Dual-tap (120, 277V 60Hz)—50W HPS only
- 480V 60Hz
- Tri-tap (120, 277, 347V 60Hz)

Optional Voltage Ballasts (Consult Eaton's Crouse-Hinds)

- 220V or 240V 50Hz (for export)
- 220V 60Hz (for export)

Isolated Ballasts (Consult Eaton's Crouse-Hinds)

- 208, 240, or 480V (for Canada)

Hub Size:

- Standard—(2) 3/4" NPT
- Optional—(2) 25 mm (M25 x 1.5) or (2) 20 mm (M20 x 1.5)

Champ® F2MV Mini-Floodlights

Cl. I, Div. 2, Groups A, B, C, D
Cl. I, Zone 2, Group IIC

Marine locations
NEMA Type 4X
Wet locations

6L

Ordering Information:

Lamp Type	Watts	Base Catalog Number*	
		3/4" NPT Hub	25mm Hub†
High Pressure Sodium	50	F2MVSY050	F2MVS25Y050
	70	F2MVSY070	F2MVS25Y070
	100	F2MVSY100	F2MVS25Y100
	150	F2MVSY150	F2MVS25Y150
Metal Halide	70	F2MVMY070	F2MVM25Y070
	100	F2MVMY100	F2MVM25Y100
	175	F2MVMY175	F2MVM25Y175

* To complete catalog number, add voltage and options suffix(es).
† For 20mm metric threads, change 25 to 20 in catalog number. Example: F2MVS20Y050/MT.

Voltage Suffixes:

Voltage (60Hz)	Dual-Tap	Tri-Tap	Multi-Tap	480
Suffix	/DT	/TT	/MT	/480

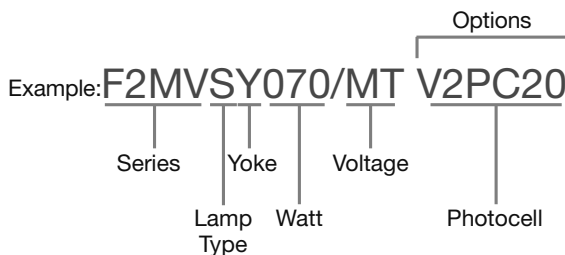

Options:

Description	Suffix
Instant Restrike and Ballast Guard	
Instant Restrike—enables a hot HPS lamp to immediately restrike after a momentary loss of arc due to voltage fluctuation or power outage	
Ballast guard starter cut out switch—prevents starter pulsing when lamp is cycling or inoperative; prolongs ballast and ignitor life	
• 150W LX HPS only.....	TIR
Factory assembled with HID lamp installed.....	FA
Fused (not suitable for marine applications).....	S658
Furnished with lamps (not installed).....	S714
Pulse-start metal halide only.....	S828
Photocell 120V, 50/60Hz installed.....	V2PC20
Photocell 208-240V, 50/60Hz installed.....	V2PC22
Photocell 277V, 50/60Hz installed.....	V2PC27

Photometrics are available online.

Photometric Data:

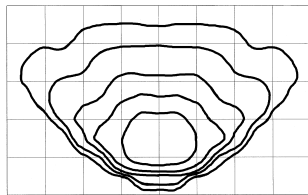

Isofootcandle Chart F2MV
150W High Pressure Sodium (HPS)
Catalog Number: F2MVSY150
Lamp: 150W Clear HPS
Lumen Rating: 16,000

For 100W HPS, multiply footcandles by .55.
For 70W HPS, multiply footcandles by .40.
For 50W HPS, multiply footcandles by .24.

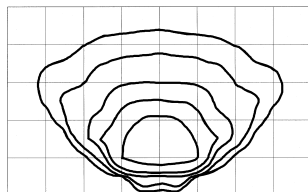

Isofootcandle Chart F2MV
175W Metal Halide (MH)
Catalog Number: F2MVMY175
Lamp: 175W Clear MH
Lumen Rating: 14,000

For 100W MH, multiply footcandles by .58.
For 70W MH, multiply footcandles by .37.

Accessories (Order Separately):

- Slipfitter adapter**
To be mounted to yoke mount fixture
Fits onto 2" pipe/conduit..... **SFA6**
- Wall bracket**
Use with slipfitter adapter
SFA6 for easy wall mounting and increased adjustability..... **SWB6**

Effective Projected Area (EPA):

- For windloading
- For proper pole selection

Aiming Angle	EPA
0°	1.6 FT ²
30°	1.6 FT ²
60°	1.1 FT ²

Footcandle Table:

6L

Mounting Height	Footcandle Values for Isofootcandle Lines				
	A	B	C	D	E
10'	8.00	4.00	2.00	0.80	0.40
15'	3.56	1.78	0.89	0.36	0.18
20'	2.00	1.00	0.50	0.20	0.10
25'	1.28	0.64	0.32	0.13	0.06
30'	0.89	0.44	0.22	0.09	0.04

Photometrics are available online.

Champ® F2MV Mini-Floodlights

Cl. I, Div. 2, Groups A,B,C,D
Cl. I, Zone 2, Group IIC

Marine locations
NEMA Type 4X
Wet locations

6L

Temperature Performance Data:

Catalog Series	Lamp		40°C Ambient			55°C Ambient			65°C Ambient			Fixture Aiming	
			Temperature Code			Temperature Code			Temperature Code				
	Type	Watts	Class I, Zone 2	Class I, Div. 2	Supply Wire °C	Class I, Zone 2*	Class I, Div. 2	Supply Wire °C	Class I, Zone 2*	Class I, Div. 2	Supply Wire °C	Range	Figure
F2MVS	High Pressure Sodium	50	T6	T3C	75	T6	T3C	75	T3B	T5	75	90°	1
		70	T6	T3A	60	T5	T3A	75	T3	T4	85	90°	1
		100	T4	T2D	75	T4	T2C	90	-	-	-	90°	1
		150**	T4	T2A	75	T4	T2A	85	T3	T2A	110	90°	1
F2MVM	Metal Halide	70	T6	T3C	75	T5	T3A	75	T4	T3A	85	90°	1
		100	T4	T2D	75	T4	T2D	75	T4	T2C	85	90°	1
		175**	T3	T2A	75	T3	T2A	85	T3	T2A	110	90°	1

*Restricted breathing explosion protection, requires suffix S826 (TB).
**Suitable for use in 65°C ambient without optional fuses.

Lamp Selection (Mogul Base):

Fixture	Watts	Type	Bulb	G.E.	Osram	Philips	Venture
F2MVSY050	50	HPS	ED23 ½ or ET23 ½	LU50	LU50	C50S68	-
F2MVSY070	70	HPS	ED23 ½ or ET23 ½	LU70	LU70	C70S62	-
F2MVSY100	100	HPS	ED23 ½ or ET23 ½	LU100	LU100	C100S54	-
F2MVSY150	150	HPS	ED23 ½ or ET23 ½	LU150/55	LU150/55	C150S55	-
F2MVMY070	70	MH	ED28	-	-	-	MH70W/U/ED28
F2MVMY100	100	MH	ED28	-	-	-	MH100/U/ED28
F2MVMY175	175	MH	ED28 or BT28	MVR175/C/U	M175/C/U	MH175/C/U	MH175/C/U

Weights and Dimensions:

Fixture Weight: 26 lbs.

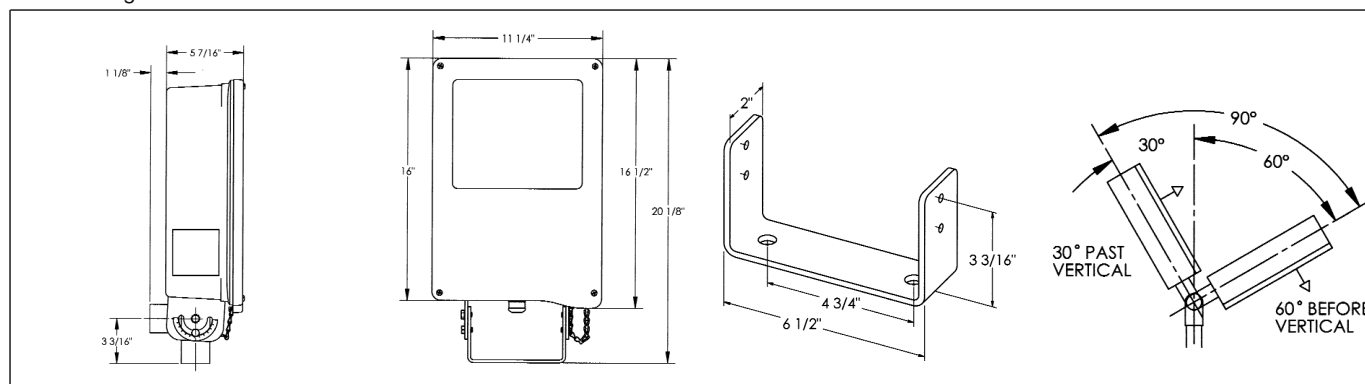

Photometrics are available online.

6L FZD Series Floodlight Luminaire

Cl. I, Div. 1 & 2, Groups C, D
 Cl. I, Zone 1
 Marine Locations
 Wet Locations, IP66

Finally, a true floodlight luminaire for hazardous areas.

Eaton's Crouse-Hinds FZD Series Luminaires are the first to deliver NEMA 7 x 6 floodlight distribution patterns for Class I, Division 1 and Zone 1 environments. That means you'll need fewer of them to illuminate a given area. With their labor-saving features and flexible mounting options, the FZD Series is ideal for:

- Heavy process industries where flammable or explosive vapors or gases are present
- Hazardous areas, both indoors and outdoors, including those requiring elevated ambient capability, where long life and low maintenance costs are desired
- Petroleum refineries, chemical, petrochemical, and other heavy process industrial facilities
- Mounting to a wall, structure, or pole (with pole mount adapter accessory)

Features and Benefits:

- NEMA 7 x 6 floodlight distribution pattern is standard – ideal light distribution for industrial applications; requires fewer luminaires in general lighting applications than required when using general area luminaires with high bay reflectors
- Internal reflector – available in wide and narrow beam options; enclosed in glass tube, reducing maintenance and enhancing light output
- Heavy duty, cast copper-free aluminum construction with epoxy powder coat finish and stainless steel hardware – provides long life in industrial, abusive environments
- Explosionproof threaded construction – suitable for hazardous and industrial applications; easy to maintain with no bolted covers
- O-ring gaskets on all threaded openings – allow NEMA Type 4X and marine listing for the harshest outdoor environments
- 40°C, 55°C, and 65°C ambient suitability – ideal for use in high ambient temperature areas common in industrial facilities
- Factory-sealed ballast housing – keeps ballast isolated from wiring chamber
- Trunnion (yoke) mount design – standard construction provides the greatest mounting flexibility; can be vertically (wall) or horizontally (rooftop or floor) mounted
- Simple installation – requires only two bolts to mount
- Mounting flexibility – pole mount with SFA6-XP pole mount adapter (shown below) or wall or ceiling mount with FZD-KIT1 mounting accessory kit (shown above)

Certifications and Compliances:

NEC/CEC

- Class I, Division 1, Group B (with suffix -GB*), C, D
- Class I, Zone 1, Group IIB+H₂ (with suffix -GB*), IIB
- AEx d IIB+H (with suffix -GB*), IIB
- Ex d IIB+H₂ (with suffix -GB*), IIB
- Marine Locations
- Wet Locations
- Enclosure Type 4X
- IP66
- UL Listed (UL Standards 844, 1598, 1598A, 2279)
- cUL Listed (certified by UL to CSA Standard C22.2 No. 137 and CAN/CSA-E60079-1)

*See options for Group B and IIB+H: ordering information.

Standard Materials:

- Luminaire housing, covers, socket holder, lamp tube end rings – copper-free aluminum
- External hardware – stainless steel
- Glass lamp tube – heat- and impact-resistant tempered glass
- O-ring gaskets – neoprene/silicone
- Yoke – aluminum
- Trunnion adapter – brass

Standard Finishes:

- Aluminum – Corro-free™ epoxy powder coat
- Stainless steel – natural
- Brass – natural

Luminaire Weights (lbs.):

Luminaire	FZDS (HPS)	FZDM (MH)
150 watt	72	75
175 to 250 watt	77	77
400 watt	80	80



FZD with separate ballast enclosure



Pole Mount Adapter

Ratings:

Sources/Wattages (Mogul Base Lamps)

- HPS – 150, 250 & 400 watts
- MH – 175, 250 & 400 watts

Voltages

Standard Voltage Ballasts

- Multi-tap (120, 208, 240 & 277 V, 60 Hz)
- 120 V, 60 Hz
- 480 V, 60 Hz
- Tri-tap (120, 277 & 347 V, 60 Hz)

Optional Voltage Ballasts

- 220 V, 60 Hz
- 220 V, 50 Hz

Hub Size

- Standard: Two 3/4" NPT entries
- Optional: Two 25 mm (M25) entries (consult Eaton's Crouse-Hinds)

Dimensions (In Inches):

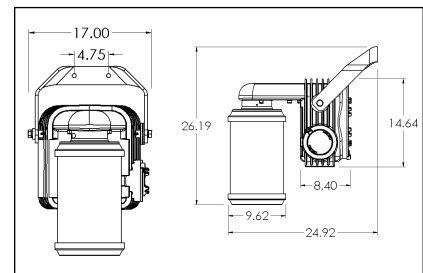

FZD Series Floodlight Luminaire

Cl. I, Div. 1 & 2, Groups C, D
 Cl. I, Zone 1
 Marine Locations
 Wet Locations, IP66

6L

Ordering Information:

Lamp Type	Watts	Cat. #* Yoke Mount With 3/4" NPT Hubs
Wide Beam Reflector – 7 x 6 Distribution		
High Pressure Sodium	150†	FZDS2NY150W/MT
	250	FZDS2NY250W/MT
	400	FZDS2NY400W/MT
Metal Halide	175	FZDM2NY175W/MT
	250	FZDM2NY250W/MT
	400	FZDM2NY400W/MT
Pulse Start Metal Halide	175	FZDM2NY175W/MT S828
	250	FZDM2NY250W/MT S828
	400	FZDM2NY400W/MT S828
Narrow Beam Reflector – Spotlight Distribution		
High Pressure Sodium	150†	FZDS2NY150N/MT
	250	FZDS2NY250N/MT
	400	FZDS2NY400N/MT
Metal Halide	175	FZDM2NY175N/MT
	250	FZDM2NY250N/MT
	400	FZDM2NY400N/MT
Pulse Start Metal Halide	175	FZDM2NY175N/MT S828
	250	FZDM2NY250N/MT S828
	400	FZDM2NY400N/MT S828

To complete the catalog number, add option suffix(es) if desired.
 Example: FZDS2NY400W/MT-S658

*All FZD catalog numbers shown above are with multi-tap ballasts (120, 208, 240 & 277 V, 60 Hz). The "MT" in the catalog number may be changed to any of the voltage suffixes listed below.

†150 watt HPS luminaires are furnished with ANSI spec/S55 ballasts for 55 V lamps.

Voltage Suffixes:

Standard Voltages	Suffix	Optional Voltages	Suffix
Multi-tap (120, 208, 240, 277 V, 60 Hz)	/MT	220 V, 50 Hz	/220 50
Tri-tap (120, 277, 347 V, 60 Hz)	/TT	220 V, 60 Hz	/220
120 V, 60 Hz	/120		
480 V, 60 Hz	/480		

Options:

Description	Suffix
Ballast-Gard™ starter cut-out switch prevents starter pulsing when lamp is cycling or inoperative; prolongs ballast and igniter life (HPS only; not available with IR option)BG
Factory assembled with HID lamp installed for additional labor savingsFA
Factory certified: Class I, Division 1, Group B and Class I, Zone 1, Group IIB + H2GB
Instant restrike enables a hot HPS lamp to immediately restrike after a momentary loss of arc due to voltage fluctuation or power outage; it has no effect on the warm-up period of cold lamps; available for use with 150 watt HPS onlyIR
Fusing protects ballast and capacitor against abnormal line conditions (not suitable for marine applications)S658*

*When ordering fuses for luminaires, option S658, you must specify the operating voltage. S658 cannot be ordered with /MT in the catalog number.

FZD With Separate Ballast Enclosure:

Glass Fiber Reinforced Polyester Ballast Enclosure With Cable Entry

Lamp Type	Watts	T-Code	Cat. #
Wide Beam Reflector – NEMA 7 x 6 Distribution			
HPS/MH	250	T4	NOR 000 005 192 506
Metal Halide	400	T3	NOR 000 005 194 106
High Pressure Sodium	400	T3	NOR 000 005 194 006
Narrow Beam Reflector – Spotlight Distribution			
HPS/MH	250	T4	NOR 000 005 192 505
Metal Halide	400	T3	NOR 000 005 194 105
High Pressure Sodium	400	T3	NOR 000 005 194 005

Stainless Steel Ballast Enclosure With Cable Entry

Lamp Type	Watts	T-Code	Cat. #
Wide Beam Reflector – 7 x 6 Distribution			
HPS/MH	250	T4	NOR 000 005 192 502
Metal Halide	400	T3	NOR 000 005 194 102
High Pressure Sodium	400	T3	NOR 000 005 194 002
Narrow Beam Reflector – Spotlight Distribution			
HPS/MH	250	T4	NOR 000 005 192 501
Metal Halide	400	T3	NOR 000 005 194 101
High Pressure Sodium	400	T3	NOR 000 005 194 001

Accessories:

For Pole Mounting	Cat. #
Pole mount adapter	SFA6-XP
Class I, Division 1, Groups B, C, D	
Attach to yoke; fits 2" NPT conduit pole	
Flexible explosionproof coupling	ECLK236
Elbow fitting	EL296-SA
For Wall Or Ceiling Mounting	
Kit includes:	FZD-KIT1
EABC26-SA conduit outlet box, ECLK236 flexible explosionproof coupling, and EL296-SA elbow fitting	

Temperature Performance Data:

Lamp	Ambient Temp. °C	Class I, Division 1, Zone 1	Supply Wire °C
150 watt HPS	40	T3C	75
	55	T3C	75
	65	T3B	90
250 watt HPS	40	T3C	75
	55	T3C	75
	65	T3B	90
400 watt HPS	40	T3C	75
	55	T3C	75
	65	T3B	90
175 watt Metal Halide	40	T3A	75
	55	T3	75
	65	T3	90
250 watt Metal Halide	40	T3A	75
	55	T3	75
	65	T3	90
400 watt Metal Halide	40	T3A	75
	55	T3	75
	65	T3	90

Photometrics:

Note: There are no aiming angle limitations for the FZD. The only limitations are those encountered by interference of the trunnion arm. The trunnion arm may be mounted on vertical or horizontal surfaces to overcome any limitations.

HPS Narrow Beam Reflector

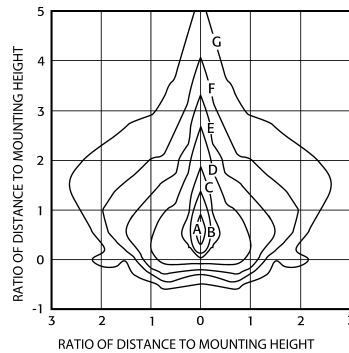

Isofootcandle Chart
 FZD 400W High Pressure Sodium (HPS)
 Catalog Number FZDS2NY400N
 Lamp: 400 W Clear HPS
 Lumen rating: 50,000
 Luminaire located at 0°, 0° Aiming Angle
 at 45° down from horizontal
 For 150W HPS, multiply footcandles by 0.32.
 For 250 W HPS, multiply footcandles by 0.6.

Footcandle Values For Isofootcandle Lines

Mtg. Ht.	A	B	C	D	E	F	G
10'	200.00	100.00	50.00	20.00	10.00	5.00	2.00
12'	138.89	69.44	34.72	13.89	6.94	3.47	1.39
16'	78.13	39.06	19.53	7.81	3.91	1.95	0.78
20'	50.00	25.00	12.50	5.00	2.50	1.25	0.50
25'	32.00	16.00	8.00	3.20	1.60	0.8	0.32

HPS Wide Beam Reflector

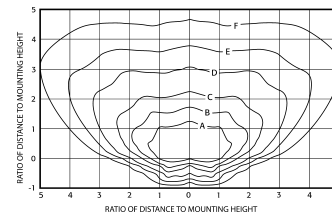

Isofootcandle Chart
 FZD 400W High Pressure Sodium (HPS)
 Catalog Number FZDS2NY400W
 Lamp: 400W Clear HPS
 Lumen rating: 50,000
 Luminaire located at 0°, 0° Aiming Angle
 at 45° down from horizontal
 For 150W HPS, multiply footcandles by 0.32.
 For 250W HPS, multiply footcandles by 0.6.

Footcandle Values For Isofootcandle Lines

Mtg. Ht.	A	B	C	D	E	F
10'	20.00	10.00	5.00	2.00	1.00	0.50
12'	13.89	6.94	3.47	1.39	0.69	0.35
16'	7.81	3.91	1.95	0.78	0.39	0.20
20'	5.00	2.50	1.25	0.50	0.25	0.13
25'	3.20	1.60	0.80	0.32	0.16	0.08

MH Narrow Beam Reflector

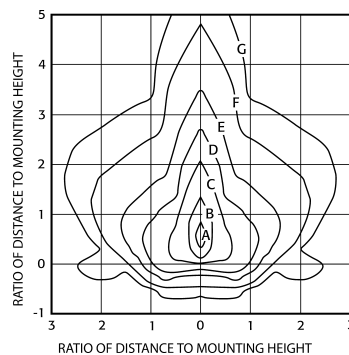

Isofootcandle Chart
 FZD 400W Metal Halide (MH)
 Catalog Number FZDM2NY400N
 Lamp: 400W Clear MH
 Lumen rating: 34,000
 Luminaire located at 0°, 0° Aiming Angle
 at 45° down from horizontal
 For 175W MH, multiply footcandles by 0.38.
 For 250W MH, multiply footcandles by 0.6.

Footcandle Values For Isofootcandle Lines

Mtg. Ht.	A	B	C	D	E	F	G
10'	100.00	50.00	20.00	10.00	5.00	2.00	1.00
12'	64.99	34.72	13.89	6.94	3.47	1.39	0.69
16'	39.06	19.53	7.81	3.91	1.95	0.78	0.39
20'	25.00	12.50	5.00	2.50	1.25	0.50	0.25
25'	16.00	8.00	3.20	1.60	0.80	0.32	0.16

MH Wide Beam Reflector

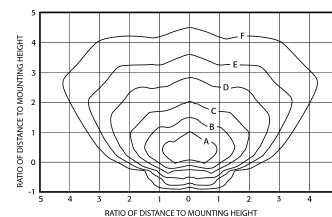

Isofootcandle Chart
 FZD 400W Metal Halide (MH) Catalog Number FZDM2NY400W
 Lamp: 400W Clear MH
 Lumen rating: 34,000
 Luminaire located at 0°, 0° Aiming Angle
 at 45° down from horizontal
 For 175W MH, multiply footcandles by 0.38.
 For 250W MH, multiply footcandles by 0.6.

Footcandle Values For Isofootcandle Lines

Mtg. Ht.	A	B	C	D	E	F
10'	20.00	10.00	5.00	2.00	1.00	0.50
12'	13.89	6.49	3.47	1.39	0.69	0.35
16'	7.81	3.91	1.95	0.78	0.39	0.20
20'	5.00	2.50	1.25	0.50	0.25	0.13
25'	3.20	1.60	0.80	0.32	0.16	0.08

Effective Projected Area (EPA):

- For windloading
- For proper pole selection

Aiming Angle	EPA
0°	1.8 ft ²
45°	2.3 ft ²

Hazard•Gard® H.I.D. Floodlights

Factory-sealed

Cl. I, Div. 1 & 2, Groups C, D
Cl. I, Div. 1 & 2, Groups B, C, D (add suffix GB)
Cl. I, Zone 1
Marine Locations, IP66
Wet Locations

6L

Applications:

Hazard•Gard Luminaires with Trunnion Arm (S812 suffix) and EV912 High Bay Reflector are used in:

- Heavy process industries where flammable or explosive vapors or gases are present
- Hazardous areas, both indoors and outdoors where long life and low maintenance costs are desired
- Petroleum refineries, chemical, petrochemical, and other heavy process industry facilities
- Hazardous locations requiring elevated ambient capability
- For mounting to a wall or structure
- Mounted on a pole, when used with the SFA6 slipfitter adapter

Features:

- Luminaire is factory wired; power is fed through "wireless" connection block which serves as a mechanical seal between conduit and ballast compartments, eliminating the need for an external, field-installed seal; the result is fast, easy installation
- High bay reflectors of Alzak® aluminum
- Internally fluted glass globes reduce glare and provide comfortable viewing light
- Wide range of light sources and wattages to meet specific lighting needs – 50, 70, 100, 150, 200, 250 and 400W high pressure sodium (HPS); 70, 100, 175, 250 and 400W metal halide (MH)
- High power factor (90%+) ballasts reduce power costs – allow more luminaires per circuit
- Elevated ambient capability permits reliable operation at high ambient temperature; selected luminaires are suitable for ambient temperatures up to 65°C
- Integral ballasts – separate ballasts are not required; lowest installed cost
- Factory-sealed, porcelain, mogul base socket
- The trunnion arm gives you the ability to offer a Hazard•Gard floodlight with varying degrees of adjustability between -90° and +90°
- When mounting on a wall, there are numerous mounting arrangements – due to the pre-drilled openings in the wall bracket

Certifications and Complies:

- NEC/CEC:
Class I, Division 1 and 2, Groups B (with GB suffix), C, D
- UL Standard: 844, 595
- CSA Standard: C22.2 No. 137

*CSA certified luminaires are not available with multi-tap ballast or S658 fuse option. Alzak is a registered trademark of ALCOA.

Crouse-Hinds

by **E•T•N**

Standard Materials:

- Mounting module, cover, ballast housing, guard, globe ring – copper-free aluminum
- Globe – heat- and impact-resistant glass
- Exterior hardware – stainless steel
- Lamp socket – porcelain with stainless steel screw shell
- Reflector – high bay: Alzak aluminum

Standard Finishes:

- Copper-free aluminum – epoxy powder coat
- Alzak – natural (anodized)

Options:

Description	Suffix
Fused.....	S658
Not suitable for marine applications	
Ballast-Gard™.....	BG
50-400 HPS only	
Instant Restrike.....	IR
Cannot be used with BG or QTZ options	
Quartz Auxiliary Lighting.....	QTZ
Not available with 400W MH	
Uses 100 watt single-ended lamp	
Lamp not included	
Group B Suitability.....	GB

Size Ranges:

- ¾"

Electrical Rating Ranges:

- 120, 208, 240, 277, 347, 480, 600, multi-tap*
- 50 to 400 watts

Ordering Information

Catalog number includes guard, trunnion arm, and high bay reflector

Luminaire Cat. #	Watts	Hub Size (In.)
High Pressure Sodium		
EVMA42051/volts S812 EV3912	50	¾
EVMA42071/volts S812 EV3912	70	¾
EVMA42101/volts S812 EV3912	100	¾
EVMA42151/volts S812 EV3912	150	¾
EVMA42201/volts S812 EV3912		¾
EVMA42251/volts S812 EV3912		¾
EVMA42401/volts S812 EV3912		¾
Metal Halide		
EVMA92071/volts S812 EV3912	70	¾
EVMA92101/volts S812 EV3912	100	¾
EVMA92171/volts S812 EV3912	175	¾
EVMA92251/volts S812 EV3912	250	¾
EVMA92401/volts S812 EV3912	400	¾

Note: Replace "volts" with Suffix from Voltage Suffix Table below



Temperature Performance Data:

Hazard•Gard Luminaire with Trunnion Arm (S812 suffix)

Watts	Maximum Ambient Class I		
	40°C	55°C	65°C
High Pressure Sodium			
50	T4	T4	T3C
70	T4	T4	T3C
100	T4	T4	T3C
150	T4	T4	T3C
200	T3A	—	—
250	T3A	—	—
400	T3A	—	—
Metal Halide			
70	T3	T3	—
100	T3	T3	—
175	T3	T3	—
250	T3	T3	—
400	T2D	—	—

Note: See Section 4L for additional luminaire information.

Required Accessories:



EABC

Cat. #	Hub Size (In.)
EABC26	¾



UNL 90° Angle

Cat. #	Size
UNL205	¾ to ¾



ECGJH

Cat. #	Flexible Length	Size
ECGJH230	30	¾

6L

Incandescent Floodlights

Applications:

RCDE Incandescent Lighting Luminaires are permanently installed to provide general illumination in locations having hazardous atmospheres, such as:

- Oil refineries
- Oil and gasoline loading docks
- Aircraft servicing docks and shelters
- Distilleries
- Paint manufacturing plants
- Pumping stations
- Other Class I, Groups C and D locations

Features:

RCDE Incandescent Lighting Luminaires have fixed mountings as follows:

- RCDE-6 – junction box base with four mounting feet or 2" threaded hub (fill sealing chamber with Chico® A after conductors are in place)
- RCDE-6 adjustment allows rotation of 360° horizontally and 75° vertically
- Locking screws hold housing firmly in position
- RCDE-10 – junction box base with four mounting feet
- Door which threads into housing includes heat- and impact-resistant lens; door has notches or holes provided for ease of removing or tightening
- Factory wired leads through explosionproof seal to junction box
- Adjustment that allows rotation of 360° horizontally and 135° vertically; locking bolts or clamps hold housing firmly in position

Certifications and Complies:

- NEC/CEC:
 - RCDE – Class I, Division 1 and 2, Groups C, D; Class I, Zone 1 (see photometric data listing)
- UL Standard: 844
- CSA Standard: C22.2 No. 137 (RCDE6 only)

CEC/CSA Certified RCDE-6 - Eaton's Crouse-Hinds Canada luminaires only.

Standard Materials:

- Body – copper-free aluminum
- Lens – glass-, heat- and impact-resistant

Standard Finishes:

- Natural

Size Ranges:

- RCDE – fixed mounting – 3/4" hubs

Capacity Ranges:

- RCDE-6 – 150 watt, PAR38 or R40; 300 watt, R40 (medium base)
- RCDE-10 – 500 watt, PAR64 Ext. Mog End Prong

Ordering Information:

After identifying the hazardous area, select the model of lighting luminaire required for that area. Then from the photometric data, select appropriate Cat. No. based on type of mounting desired (Example: RCDE-10 No. 47282).



RCDE-6

Description	Cat. #
Junction box base (2" threaded hub)	44978A
Junction box base (4 mtg. feet)	44719B

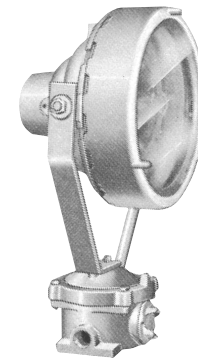

RCDE-10

Description	Cat. #
Junction box base (4 mtg. feet)	47282A

Temperature Performance Data: (based on 40°C Ambient)

	150W	300W	500W
RCDE-6	T3B	T2B	
RCDE-10			T3C

6L

Incandescent Floodlights

Dimensions (In.):

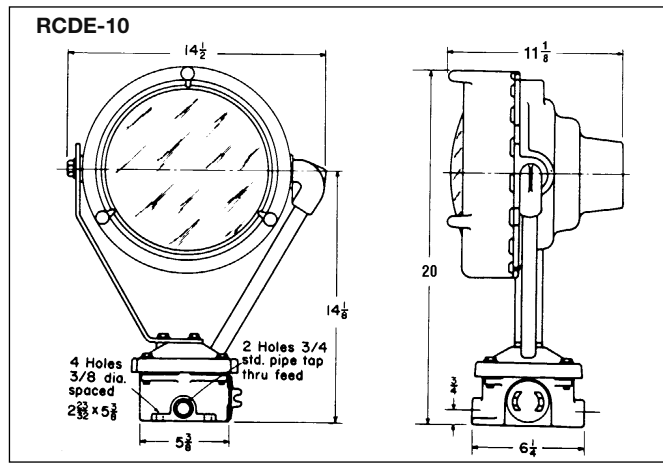
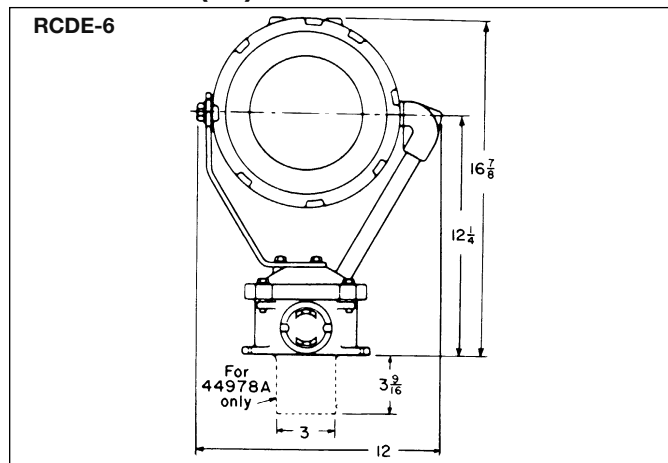

Fixture Weights:

Cat. #	Lbs. (Net)
RCDE-6	
44719B	21.0
44978A	21.0
RCDE-10	
47282A	26.0

Photometric Data:

Lamp Watts and Type	Location	Beam Spread		Beam Lumens	Av. Max. Candle Power
		Hor.	Vert.		
RCDE-6					
150 Watt PAR38 Flood	Class I, Groups C, D	60°	60°	1690	4000
150 Watt PAR38 Spot		28°	28°	1200	11500
300 Watt* R40 Flood	Class I, Group D	123°	123°	3200	1950
300 Watt R40 Spot		60°	60°	3100	8900
RCDE-10					
500 Watt, PAR64 (500 PAR64/NSP)	Class I, Group D	19°	14°	3000	110000
500 Watt, PAR64 (500 PAR64/MFL)		35°	19°	3300	37000
500 Watt, PAR64 (500 PAR64/WFL)		55°	32°	3400	13000

*CSA certified fixtures are for 150 watt lamp maximum.



6L

6L

Description	Page No.
Application/Selection	see page 1162
Hazardous Area Hangers	
Adjustable Type	
UNR	see page 1179
Flexible Type	
EC Series	see page 1173
Locking Coupling	
COUP Series	see page 1179
Outlet Box Type	
EAHC/EFHC Series	see page 1174
GUA/GUF Series	see page 1178
CPS Series	see page 1176
Outlet Box Type with Flexible Cushion	
EFHX Series	see page 1175
Non-hazardous Area Fittings	
Conduit Clamps	
CHS Series	see page 1171
Non-hazardous Area Hangers – Flexible Type	
Ball and Cushion	
ARB Series	see page 1169
UNJ/UNJC Series	see page 1167
Cushion – Vaportight	
AHG Series	see page 1167
UNHC Series	see page 1171
Hooks and Loops	
UNE, UNH, UNHC Series	see page 1170
Outlet Box – Ball and Cushion	
AL Series	see page 1166
Quick Disconnect Type	
FHM Series	see page 1172

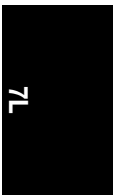

7L Luminaire Hangers and Accessories – For Pendant Mount

Application and Selection

Applications:

- Luminaire hangers listed in this section are used for pendant suspension of incandescent, high intensity discharge, and fluorescent industrial luminaires
- They are especially suitable for use in locations where moisture, dust, and corrosion are a problem

Hangers for Non-hazardous Locations:

- Hangers listed provide a wide variety of mounting means; luminaires may be suspended from cast outlet boxes, stamped steel outlet boxes, or directly from the conduit system; also offered are several styles of hook type hangers, used to suspend luminaires by means of conduit stems or support rods from span wires, horizontal conduit and luminaire loops
- All hangers are flexible, permitting luminaire and supporting stem to swing freely; this feature permits luminaires to hang plumb and prevents damage to the luminaire, stem, and outlet box in case of high wind or accidental impact
- Hangers are constructed so that luminaires cannot be rotated, thereby eliminating wire twisting and possible damage to connections
- Cushion hangers, listed for most styles, include a spring which carries the weight of the luminaire; this feature prolongs lamp life and protects the luminaire assembly from shock or vibration
- All hangers are easily installed; with many, the luminaire, stem, and support member can be assembled and wired at the work bench before making the final installation; with several, a quick disconnect plug and receptacle feature is either provided or can be easily arranged, to facilitate luminaire installation and removal for maintenance

Typical Luminaire Weights:

Luminaire Type	Weight (lbs.)	Luminaire Type	Weight (lbs.)	Luminaire Type	Weight (lbs.)
Incandescent:		H.I.D.:		Hazard-Gard® Series	
<i>VAPORGARD™ Series</i>		<i>Champ® Series</i>			
VDA12	1½	DMVC2A250GP	31¾	EVMA50W HPS	41
VDA12G	4	DMVM2A175GP	33	EVMA70W HPS	41
VDA12GP	4¼	DMVM2A250GP	33¾	EVMA100W HPS	45
VDA15	1¼	DMVS2A070GP	30¾	EVMA150W HPS (55V)	46
VDA15G	3	DMVS2A100GP	31¾	EVMA150W HPS (100V)	45
VDA15GP	3¼	DMVS2A150GP	34	EVMA175W MH	43
VDA23	1½	LMVS2A035GP	10¾	EVMA200W HPS	47
VDA23G	4	LMVS2A050GP	11¾	EVMA250W HPS	47
V Series		LMVS2A070GP	11¾	EVMA250W MH	44
V275	2¾	LMVS2A100GP	12¼	EVMA400W HPS	56
V2759	4¼	VMVM2A175GP	17¼	EVMA400W MH	52
EV Series		VMVM2A250GP	34	Fluorescent:	
EVI301	11	VMVM2A250GR305	37	DMVF2A026GP	19¼
EVI501	24	VMVM2A250GRD4	34½	DMVF2A039GP	22¼
EVA292	18	VMVM2A400GR305	38	DMVFB2A026GP	19½
Corro•Gard® Series		VMVM2A400GRD4	35½	DMVFB2A039GP	
NDA32	5½	VMVS2A050GP	15¼	EVF22062	57
NDA32G	7½	VMVS2A070GP	16¼	EVF24062	94
NDA33		VMVS2A100GP	16¼	EVF22082	52
NDA33G	8¼	VMVS2A150GP	16½	FVN4240	52
		VMVS2A200GP	31	FVN4340	54
		VMVS2A200GR305	34	FVN4260	58
		VMVS2A200GRD4	31½	NFW4240	21
		VMVS2A250GP	31	VFA222G	4
		VMVS2A250GR305	34	EVFT (2 Lamp)	19½
		VMVS2A250GRD4	31½	EVFT (4 Lamp)	36½
		VMVS2A400GP	40	FVS	12
		VMVS2A400GRD4	40½	Reflector/Refractor Type	
				EV3912	1
				RA64, 636	1¼
				RA70, 71, 739, 725	1
				RD64, 636	
				RD70, 71, 739, 725	1
				PR2, 3, 5	3
				R2	13½
				R5	13
				GRD4	13¾
				G241	2¼
				G245	2¼
				GR305, GR205	14

Considerations for Selection:

Location:

- Will it require more stringent corrosion protection material?
- Will it be a hazardous or non-hazardous location?

Lighting luminaire to be used:

- Some hangers can be used with a multitude of luminaires; others are specialized
- Weight of luminaire is a consideration in selecting cushion hangers

Hangers for Hazardous Locations:

- As required by NEC Article 501 and CEC Part I Section 18, rigid conduit luminaire stems longer than 12" must be permanently and effectively braced or flexibility provided in the form of a fitting or flexible support
- A variety of hangers is offered for both rigid conduit suspension and flexible suspension; flexible luminaire hangers listed comply with NEC Article 501 and CEC Part I Section 18 and also permit luminaires to hang plumb

Luminaire Hangers and Accessories – For Pendant Mount

7L

Quick Selector Chart

Quick Selector Chart

Hanger Type	Function	NEC/CEC Hazardous Area Compliances	Use with Luminaire Type	Use with Mtg. Box	Luminaire Weight Capacity (Cushion)	Luminaire Weight Capacity (Ball or Plain Type)	Standard Material
AL	Outlet box and hanger	Cl. I, Div. 2	Any non-hazardous or Class I, Div. 2	None needed	3-48 lbs.	125 lbs.	Body – Feraloy® iron alloy Nipple – malleable iron Cover – sheet steel
FHM	Quick disconnect between luminaire and outlet box	Not applicable	Any non-hazardous	None needed		125 lbs.	Body – copper-free aluminum Cover – steel Loop and assembly – copper-free aluminum or steel
AHG	Gasketed hanger (vaportight)	Cl. I, Div. 2; Cl. II, Div. 2; Cl. III Wet locations NEMA 3, 3R	Any non-hazardous or Div. 2 luminaires	Any	4-30 lbs.	–	Housing – malleable iron and Feraloy iron alloy Stem support – Feraloy iron alloy
UNJ/UNJC	Ball and cushion hanger	Cl. I, Div. 2	Any non-hazardous or Class I, Div. 2	Any	6-48 lbs.	125 lbs.	Body – malleable iron Clamp – copper-free aluminum
ARB	Ball or cushion hanger	Cl. I, Div. 2	Any non-hazardous or Class I, Div. 2	GRF	4-30 lbs.	125 lbs.	Body – Feraloy iron alloy
UNE, UNH, UNHC	Quick disconnect hanger hook	Cl. I, Div. 2	Any non-hazardous or Class I, Div. 2	Not applicable	12-64 lbs.	125 lbs.	Malleable iron, copperfree aluminum
EC	Explosionproof flexible hanger	Cl. I, Groups A, B, C, D; Cl. II, Groups E, F, G; Cl. III	Any hazardous	Any	–	–	Body – bronze hose Fittings – steel
GUA, GUJ, GUF	Explosionproof boxes and hanger covers	Cl. I, Groups C, D; Cl. II, Groups E, F, G; Cl. III	Any hazardous	None needed	–	125 lbs.	Boxes – Feraloy iron alloy Cover – copper-free aluminum
EAHC, EFHC	Explosionproof hanger	Cl. I, Groups A, B, C, D; Cl. II, Groups E, F, G; Cl. III	Any hazardous	None needed	–	125 lbs.	Body – Feraloy iron alloy Cover – copper-free aluminum
UNR	Explosionproof adjustable hanger	Cl. I, Groups C, D; Cl. II, Groups E, F, G; Cl. III	Any hazardous or non-hazardous	Any	–	125 lbs.	Feraloy iron alloy
EFH	Explosionproof boxes and hangers	Cl. I, Groups C, D; Cl. II, Groups E, F, G; Cl. III	Any hazardous	None needed	65 lbs.	–	Feraloy iron alloy

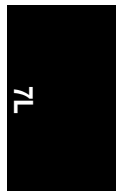

7L Luminaire Hangers and Accessories — For Pendant Mount

Typical Installations

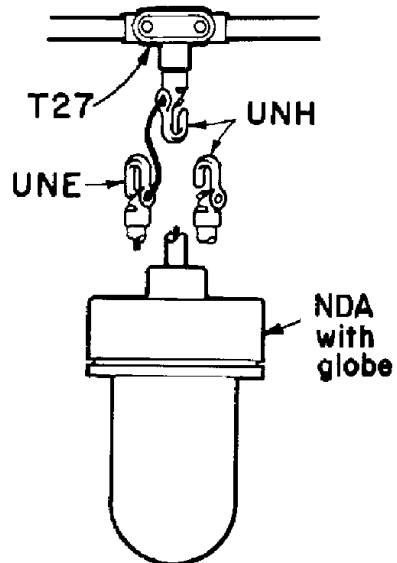
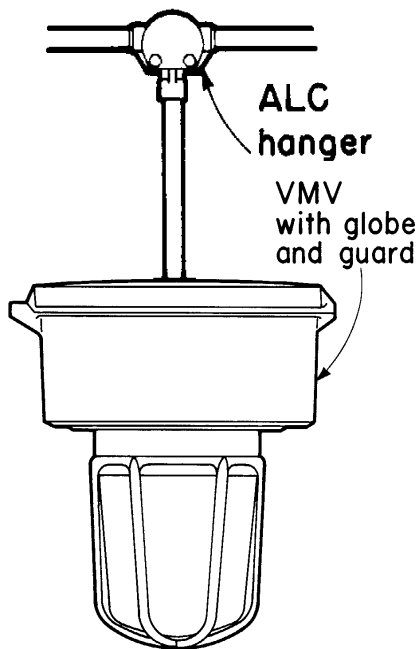
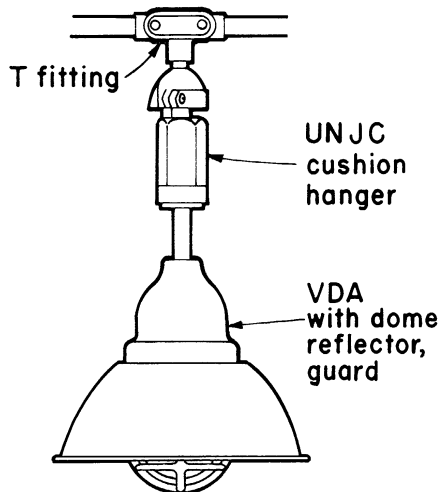
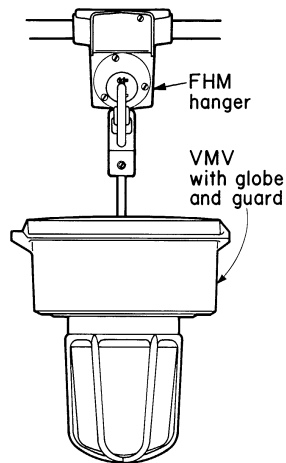
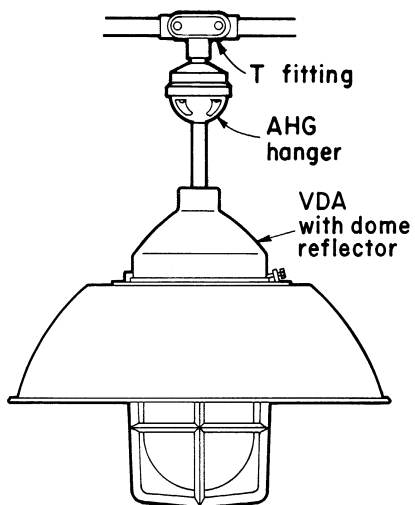

7L

Luminaire Hangers and Accessories — For Pendant Mount

7L

Typical Installations

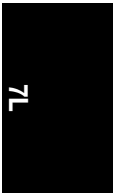
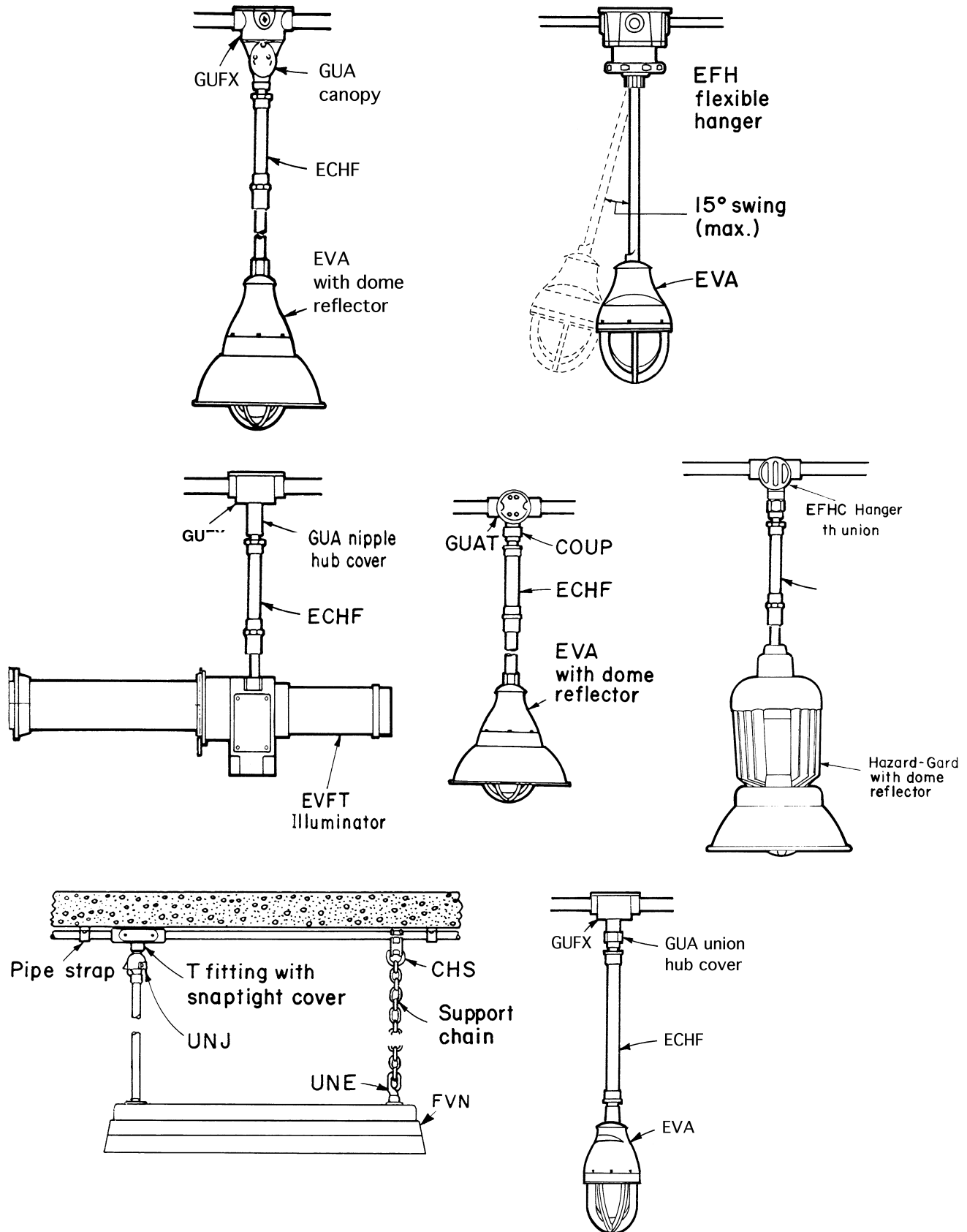

For Pendant Mount

Features:

Functions as both conduit outlet box and luminaire hanger; hubs are provided for threading the conduit directly into the hanger body; for use with incandescent, H.I.D., and fluorescent luminaires

- Supporting nipple, ball or cushion type, is a universal joint permitting luminaire to swing through an angle of 20 degrees in any direction from the perpendicular
- Cover has one screw hole and one open slot – easily swung aside for wiring without removal and possible loss of cover
- Luminaire, conduit stem, and nipple can be assembled and wired at the work bench; the assembly is then placed in the hanger body and luminaire wires spliced to the circuit wires
- Provided with a separate grounding wire for ground connections

Standard Materials:

- Body – Feraloy®
- Nipple – malleable iron
- Cover – sheet steel

Standard Finishes:

- Feraloy and malleable iron – zinc electroplate and aluminum acrylic paint
- Sheet steel – electrogalvanized with chromate finish

Size Ranges:

- Conduit hubs – 3/4" to 1"
- Luminaire stem – 1/2" and 3/4"
- Luminaire weight – cushion type, 3 to 48 lbs.; ball type, 125 lbs.

Options:

The following special options are available from the factory by adding the suffix to the Cat. No.:

Description	Suffix
Suspension attachment for span wire or threaded rod (see listings)	S1

Suspension Attachment For horizontal cable or vertical support rod

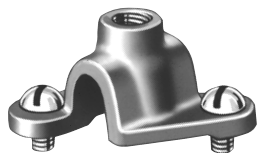

AL hangers can be furnished with a loop fastened to the top of the body to provide a means for suspending luminaires from vertical support rods or horizontal span wires. The loop will take a wire or cable with a maximum diameter of 3/8". The boss on top of the loop is tapped 3/8"-16 to accept a threaded rod.

ALC

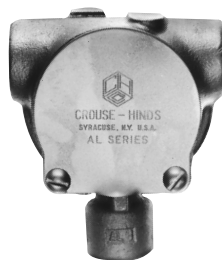

Ball



Cushion

Ball Luminaire Stem Size	Conduit Size	Cat. #
1/2	3/4	ALC21
3/4	3/4	ALC22
3/4	1	ALC32

Cushion

Luminaire Stem Size	Conduit Size	Luminaire Weight (Lbs.)	Cat. #
1/2	3/4	3 to 6	ALC214
3/4	3/4		ALC224
3/4	1		ALC324
1/2	3/4	6 to 12	ALC218
3/4	3/4		ALC228
3/4	1		ALC328
1/2	3/4	12 to 24	ALC2116
3/4	3/4		ALC2216
3/4	1		ALC3216
1/2	3/4	24 to 48	ALC2132
3/4	3/4		ALC2232
3/4	1		ALC3232

ALT



Ball



Cushion

Ball Luminaire Stem Size	Conduit Size	Cat. #
1/2	3/4	ALT21
3/4	3/4	ALT22
3/4	1	ALT32

Cushion

Luminaire Stem Size	Conduit Size	Luminaire Weight (Lbs.)	Cat. #
1/2	3/4	3 to 6	ALT214
3/4	3/4		ALT224
3/4	1		ALT324
1/2	3/4	6 to 12	ALT218
3/4	3/4		ALT228
3/4	1		ALT328
1/2	3/4	12 to 24	ALT2116
3/4	3/4		ALT2216
3/4	1		ALT3216
1/2	3/4	24 to 48	ALT2132
3/4	3/4		ALT2232
3/4	1		ALT3232

AHG, UNJ and UNJC Flexible Luminaire Hangers

For Pendant Mount

AHG – Cl. I, Div. 2, Groups A, B, C, D
 Cl. II, Div. 2, Groups F, G
 Cl. III
 Wet Locations, NEMA 3, 3R
 UNJ, UNJC – Cl. I, Div. 2, Groups A, B, C, D

7L

Features:

- For connection to conduit hub or hub cover of supporting conduit fitting
- For incandescent, H.I.D., and fluorescent luminaires
- Cushion support for conduit stem is a universal joint permitting luminaire to swing through an angle of 8 degrees in any direction from the perpendicular
- Gasketed by means of a durable neoprene diaphragm which excludes moisture and dirt from both luminaire and conduit system

Certifications and Compliances:

- Class I, Division 2
- Class II, Division 2
- Class III
- Wet Locations
- NEMA 3, 3R

Standard Materials:

- Housing: top cap – malleable iron; bottom cap – *Feraloy*® iron alloy
- Luminaire stem support – *Feraloy* iron alloy

Standard Finishes:

- *Feraloy* iron alloy and malleable iron – electrogalvanized and aluminum acrylic paint

Size Ranges:

- Male nipple – 3/4"
- Luminaire stem – 3/4"
- Luminaire weight – 4 to 30 lbs.

AHG

Cushion Vaportight for Class I, Div. 2; Class II, Div. 2; Class III



Luminaire Stem Size*	Male Nipple Size*	Luminaire Weight (Lbs.)	Cat. #
3/4	3/4	4 to 8	AHG22103
3/4	3/4	8 to 16	AHG22104
3/4	3/4	16 to 30	AHG22111

Features:

- For connection to conduit hub or hub cover of supporting conduit fitting
- For incandescent, H.I.D., and fluorescent luminaires
- Supporting nipple, ball or cushion type, is a universal joint permitting luminaires to swing through an angle of 20 degrees in any direction from the perpendicular

Certifications and Compliances:

- NEC: Class I, Division 2

Standard Materials:

- Body and nipple – malleable iron
- Clamp – copper-free aluminum

Standard Finishes:

- Malleable iron – electrogalvanized and aluminum acrylic paint
- Copper-free aluminum – natural finish

Size Ranges:

- Male nipple – 1/2" and 3/4"
- Luminaire stem – 1/2" and 3/4"
- Luminaire weight: cushion type – 6 to 48 lbs.; ball type – 125 lbs.

UNJ

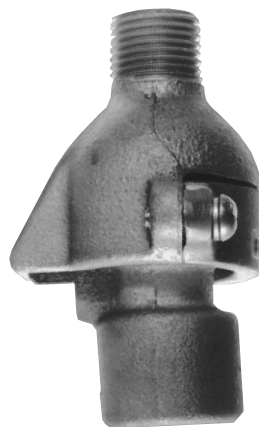

Ball

Luminaire Stem Size	Male Nipple Size	Cat. #
1/2	1/2	UNJ1
3/4	3/4	UNJ2

UNJC

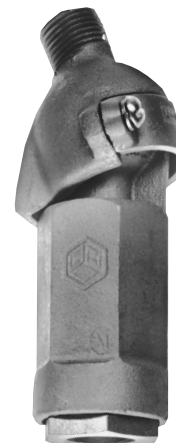

Cushion

Luminaire Stem Size*	Male Nipple Size*	Luminaire Weight (Lbs.)	Cat. #
3/4	3/4	6 to 12	UNJC28
3/4	3/4	12 to 24	UNJC216
1/2	1/2	24 to 48	UNJC132
3/4	3/4	24 to 48	UNJC232

*1/2" connection can be made by using reducers.

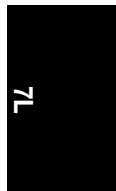

7L Flexible Luminaire Hangers

For Pendant Mount Dimensions

Dimensions

In Inches:

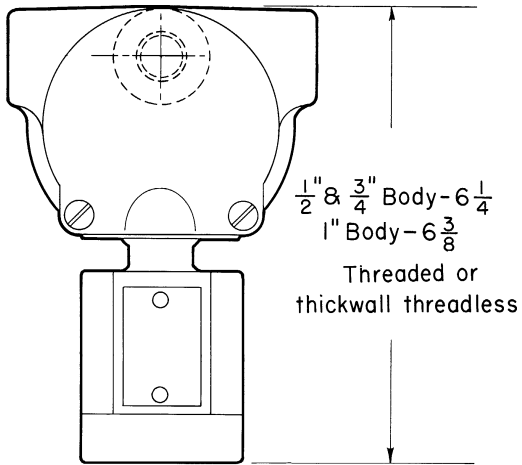

AL Series - Cushion

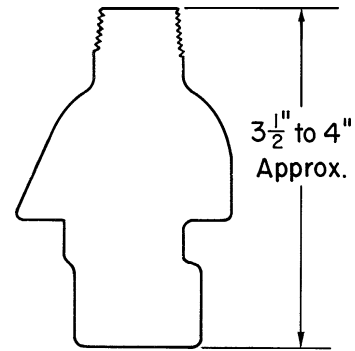

UNJ

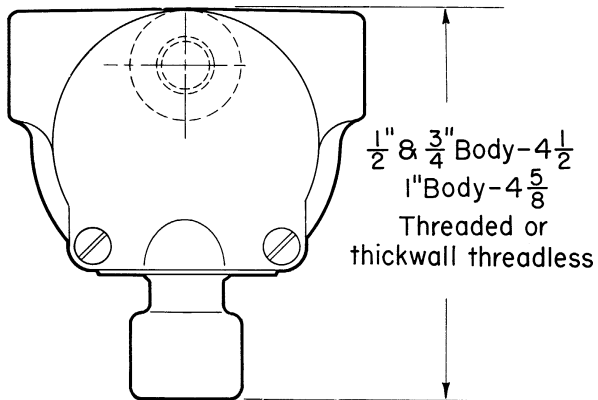

AL Series - Ball

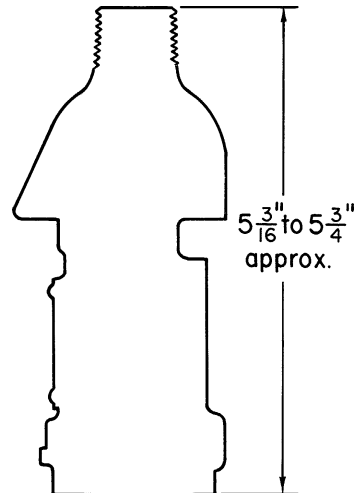

UNJC

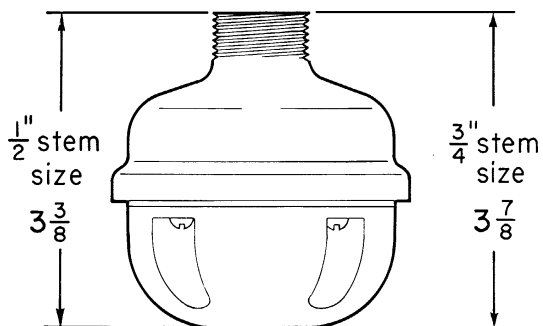

AHG

7L

For Pendant Mount

Features:

- Available in two styles – one for direct attachment to GRF cast outlet boxes by 4 screws, the other for direct attachment to 4" octagonal stamped steel outlet boxes by 2 screws; for incandescent, H.I.D., and fluorescent luminaires
- Both styles available with ball or cushion support for conduit stem to permit luminaire swing in any direction; ball type provides 11 degree swing, cushion type 8 degree swing from the perpendicular
- Gasketed cushion hangers for GRF are provided with a durable neoprene diaphragm which excludes moisture and dirt from both luminaire and conduit system

Standard Materials:

- Mounting plate for GRF – *Feraloy*® iron alloy; for 4" outlet boxes – sheet steel
- Hanger body and luminaire stem support – *Feraloy* iron alloy

Standard Finishes:

- *Feraloy* – electrogalvanized and aluminum acrylic paint
- Sheet steel – electrogalvanized with chromate finish

Size Ranges:

- Luminaire stem – 1/2" and 3/4"
- Luminaire weight: cushion type – 4 to 30 lbs.; ball type – 125 lbs. (ARB6 and ARB2 maximum weight 60 lbs.)

For GRF and VXF outlet boxes only

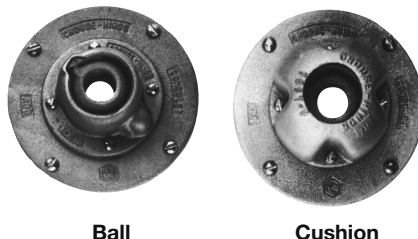

Ball

Cushion

For GRF and VXF outlet boxes and 4" octagonal outlet boxes

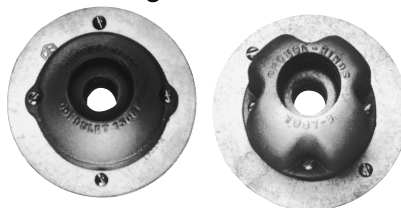

Ball

Cushion

ARB Fits GRF and VXF Outlet Boxes Ball

Description	Luminaire Stem Size	Luminaire Weight (Max.)	Cat. #
Surface	1/2	125	ARB62
Flush	1/2	125	ARB67
Surface	3/4	125	ARB662

Cushion Surface

Luminaire Stem Size	Luminaire Weight (Lbs.)	Cat. #
1/2	4 to 8	ARB82
1/2	8 to 16	ARB102
1/2	16 to 30	ARB122

Cushion Surface – Vaportight with Neoprene Diaphragm

Luminaire Stem Size	Luminaire Weight (Lbs.)	Cat. #
1/2	4 to 8	ARB821
1/2	8 to 16	ARB1021
1/2	16 to 30	ARB1221

ARB Fits GRF, VXF and 4" Outlet Boxes Ball

Luminaire Stem Size	Luminaire Weight (Max.)	Cat. #
1/2	60	ARB6
3/4	60	ARB2

Cushion

Luminaire Stem Size	Luminaire Weight (Lbs.)	Cat. #
1/2	4 to 8	ARB8
1/2	8 to 16	ARB10
1/2	16 to 30	ARB12

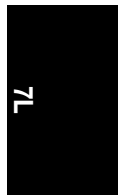

7L UNE, UNH and UNHC Flexible Luminaire Hangers

Cl. I, Div. 2, Groups A, B, C, D

For Pendant Mount

The following applies to all items on this page:

Applications:

- Provides a simple, inexpensive, quick disconnect method for hanging pendant luminaires; for incandescent, H.I.D., and fluorescent luminaires
- Permits free swing in any direction to prevent damage to luminaire stem; cushion style provides additional protection from vibration to prolong lamp life

Features:

- Female hooks and loops are used with rigid conduit luminaire stems to suspend luminaires; they may also be used with male hooks and loops, threaded into a conduit outlet hub
- All hooks and loops are provided with openings for passage of luminaire wires; luminaire, conduit stem, and hook or loop can be assembled and wired at the work bench; the assembly is then hung on the fixed hook and connection made
- For ease of relamping and maintenance, the outlet fitting can be equipped with an attachment plug receptacle cover and a matching plug cap used with the luminaire assembly; for permanent wiring, a wire hole cover may be used

Applicable to UNE and UNH (upper listings) only:

Features:

- Diameter of wire opening: 1/2"

Standard Materials:

- Malleable iron

Standard Finishes:

- Cadmium electrogalvanized and aluminum acrylic paint

Size Ranges:

- Luminaire stem or hub – 1/2" and 3/4"
- Luminaire weight – 125 lbs.

Applicable to UNH and UNHC (lower listings) only:

Features:

- Hooks are shaped to permit easy installation of large heavy luminaires, such as H.I.D. and fluorescent units
- Diameter of wire opening: 3/8"

Standard Materials:

- Copper-free aluminum

Standard Finishes:

- Natural

Size Ranges:

- Luminaire stem – 1/2" and 3/4"
- Luminaire weight: cushion type – 12 to 64 lbs.; plain type – 125 lbs.



Male



Female



Male



Female

UNH

UNE

UNE and UNH Flexible Luminaire Hangers For Pendant Mount

Type	Style	Luminaire Stem Size	Luminaire Weight (Lbs.)	Cat. #
UNH	Male	1/2	125	UNH16
		3/4	125	UNH26
	Female	1/2	125	UNH1
		3/4	125	UNH2
UNE	Male	1/2	125	UNE16
		3/4	125	UNE26
	Female	1/2	125	UNE1
		3/4	125	UNE2



Female



Female Cushion

UNH and UNHC Flexible Luminaire Hangers

Type	Style	Luminaire Stem Size	Luminaire Weight (Lbs.)	Cat. #
UNH	Female	1/2	125	UNH182
UNHC	Female Cushion	3/4	12 to 24	UNHC216
		3/4	24 to 48	UNHC232
		3/4	48 to 64	UNHC264

Crouse-Hinds
by E.T.N

**For Support Only
CHS Conduit Clamp; UNH Conduit Hook;
For Pendant Mount Fluorescent Luminaires**

Applications:

- Used for support of pendant fluorescent luminaires
- UNHC provides cushion support for luminaires suspended by 1/4" or 5/16" threaded rod, and is used with the ring of CHS conduit clamps
- UNH hook provides an extremely simple means of conduit suspension for the unwired end of a fluorescent luminaire, as it merely hooks over the horizontal supporting conduit

Features:

- The bushing in UNHC cushion hangers is tapped for both 1/4" and 5/16" suspension rod, with the lower half tapped 5/16"; either size rod can be used without reversing the bushing
- CHS conduit clamp firmly grips the conduit and the ring at bottom accepts either a hooked rod or the UNHC cushion hanger for threaded rod; will also accept UNH and UNHC hangers for conduit stem listed on the preceding page
- The UNH conduit hook fits over conduit up to and including 1" and has a hub for attachment of a 1/2" conduit stem

Standard Materials:

- UNHC – copper-free aluminum
- CHS: body – malleable iron; clamp – copper-free aluminum; ring – steel wire
- UNH – *Feraloy*® iron alloy

Standard Finishes:

- Copper-free aluminum – natural finish
- *Feraloy* and malleable iron – electrogalvanized and aluminum acrylic paint
- Steel wire – electrogalvanized with chromate finish

Size Ranges:

- Luminaire stem (UNH) – 1/2"
- Conduit (CHS): 1/2" to 1"
- Luminaire weight: UNHC cushion – 12 to 64 lbs.; CHS, UNH – 125 lbs.

UNHC Cushion Luminaire Hangers

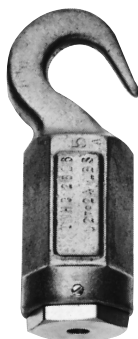

Luminaire Weight (Lbs.)	Support Rod Tap	Cat. #
12 to 24	1/4"-20	UNHC2816
24 to 48	and	UNHC2832
48 to 64	5/16"-18	UNHC2864

CHS Conduit Clamp and UNH Hook



Conduit Size	Clamp		Hook	
	Clamp Cat. #	Hook Cat. #	Hook Hub Size	
1/2	CHS1437	UNH13	1/2	
3/4	CHS2437			
1	CHS3437			

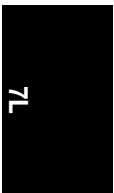

7L FHM Power Hook Luminaire Hangers

For Pendant Luminaires

Features:

- For mounting H.I.D. type luminaires in non-hazardous locations
- Power hook housing has two 3/4" through-feed hubs and one 3/4" hub on the top for pendant mounting; through-feed hubs are furnished with flush plugs
- Cast mounting lugs are provided for direct ceiling mounting
- Housing contains a roomy 15 cu. in. splicing chamber and interlocking type receptacle with leads
- Plugs and receptacles are interlocking type to prevent accidental disengagement; when plug is inserted, hook is blocked and luminaire assembly cannot be removed; to service the luminaire, pull the plug, unhook the loop luminaire assembly, and take it to a convenient servicing area
- Loop can move a maximum of 30°, allowing the power hook to be mounted on a canted ceiling; the luminaire assembly will hang true to the vertical
- Loop and hook are shaped for self-alignment and resist twisting of luminaire by gusts of wind or light drafts
- Supporting loop is furnished with 16" of #16-3/C type SO cord and an interlocking type plug

Certifications and Compliances:

- Meet UL and NEMA requirements for the listed electrical ratings

Standard Materials:

- Power hook body – copper-free aluminum
- Access cover – zinc plated cold rolled steel
- Loop – copper-free aluminum

Standard Finishes:

- Copper-free aluminum – natural finish
- Steel – electrogalvanized with chromate finish

Size Ranges:

- Hubs – 3/4"
- Luminaire weights: loop – up to 125 lbs.
- Loop luminaire stem size – 3/4"

Electrical Rating Ranges:

- 480 volts, 14 amps, 2 wire, 3 pole

FHM

For H.I.D. Type Luminaires with Voltages up to 480 Volts

Loop	Hubs*	Luminaire Stem*	Luminaire Weight (Lbs.)	Cat. #
Plain	3/4"	3/4"	125	FHM201

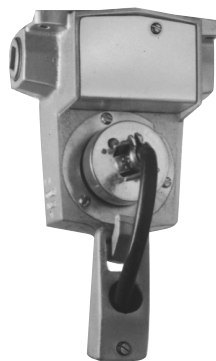

Plain

Dimensions In Inches:

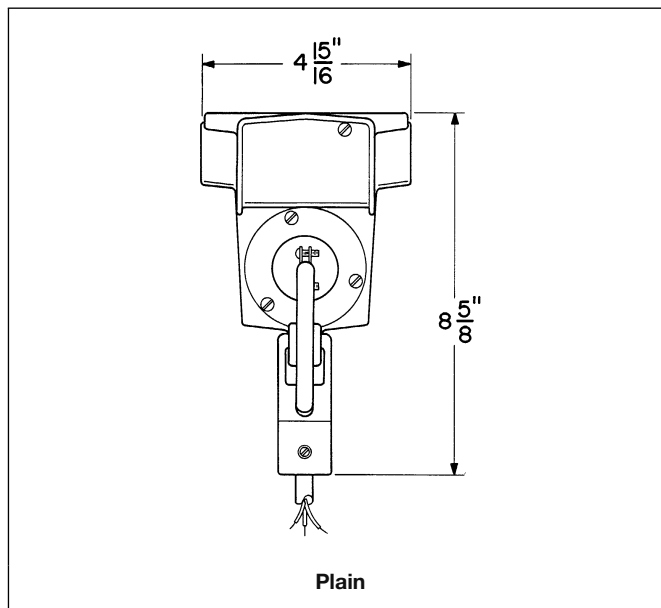

Plain

*1/2" connection can be obtained by using reducers.

ECHF Flexible Luminaire Supports

For Pendant Mount

Cl. I, Div. 1 & 2, Groups A, B, C, D
 Cl. II, Div. 1, Groups E, F, G
 Cl. II, Div. 2, Groups F, G
 Cl. III

Explosionproof
 Dust-Ignitionproof

7L

Applications:

ECHF Series Flexible Luminaire Supports are used in hazardous locations:

- Where a luminaire must hang more than 12" from its supporting junction box (as specified by NEC Article 501 and CEC Part I Section 18)
- To assure that luminaires hang plumb and will swing freely if accidentally struck; prevents damage to luminaire and supporting outlet fitting

Features:

- Complies with NEC Article 501/CEC Part I Section 18
- Free swinging in any direction through a large arc
- Good electrical continuity – no bonding jumpers needed
- Watertight construction
- Insulating liner of asphalt impregnated fiber to protect conductors
- Constructed to reinforced flexible metal hose
- Two female end fittings, each with a removable short nipple
- Nipples fit set-screw type luminaire hubs
- Female end fittings are equipped with set-screws to prevent turning during relamping and loosening of fitting with vibrations

Certifications and Compliances:

- NEC/CEC:
 - Class I, Groups A, B, C, D
 - Class II, Groups E, F, G
 - Class III
- UL Standard: 1203
- CSA Standard: C22.2 No. 30

Standard Finishes:

- Brass and bronze – natural

Standard Materials:

- Inner core – brass
- Outer braid – bronze
- End fittings – bronze
- End fittings – brass (CSA certified units)

Options:

Description	Suffix
Material – stainless steel hose and end fittings.....	S516
Finish – flexible neoprene protective coating.....	S758
Special lengths and sizes available.....	Detailed information on request

Size Ranges:

- Flexible length – 4" to 18"
- Nipple size – 1/2" and 3/4" (see "Options")
- Luminaire weight – up to 125 lbs.

Crouse-Hinds

by **E.T.N**



ECHF

Ordering Information:

Description			
Flexible Length	Nipple Size	Overall Length	Cat. #
4	1/2	10	ECHF14
	3/4	10	ECHF24
6	1/2	12	ECHF16
	3/4	12	ECHF26
8	1/2	14	ECHF18
	3/4	14	ECHF28
10	1/2	16	ECHF110
	3/4	16	ECHF210
12	1/2	18	ECHF112
	3/4	18	ECHF212
15	1/2	21	ECHF115
	3/4	21	ECHF215
18	1/2	24	ECHF118
	3/4	24	ECHF218



7L EAHC and EFHC Luminaire Hangers

For Pendant Mount

Cl. I, Div. 1 & 2, Groups A*, B*, C, D
 Cl. II, Div. 1, Groups E, F, G
 Cl. II, Div. 2, Groups F, G
 Cl. III

Explosionproof
 Dust-Ignitionproof

Applications:

EAHC and EFHC Luminaire Hangers are for use in hazardous areas to:

- Suspend explosionproof pendant luminaires from the conduit system
- Function as both conduit outlet box and luminaire hanger

Features:

- Through-feed hubs are provided for threading the conduit directly into the hanger body
- Has large threaded cover for accessibility and ease of wiring
- Bottom hub, threaded or union style, is equipped with set-screws to securely lock luminaire stem in place; takes conduit stem or EC flexible luminaire hanger for stems longer than 12" (in compliance with NEC Article 501 and CEC Part I Section 18)

Certifications and Compliances:

- NEC/CEC:
 - EAHC –
 - Class I, Groups A, B, C, D
 - Class II, Groups E, F, G
 - Class III
 - EFHC –
 - Class I, Groups C, D
 - Class II, Groups E, F, G
 - Class III

- UL Standard: 1203
- CSA Standard: C22.2 No. 20

Standard Materials:

- Bodies – *Feraloy*® iron alloy
- Covers – copper-free aluminum

Standard Finishes:

- *Feraloy* – electrogalvanized and aluminum acrylic paint
- Copper-free aluminum – natural

Options:

Description **Suffix**
 Finish – *Corro-free*™ epoxy enamel **S752**

Suspension attachment for span wire or threaded rod (see listings) **S1**

Mounting strap (see listings) **S294**

Size Ranges:

- Conduit hubs – ¾" and 1"
- Luminaire stem – ½" and ¾"
- Luminaire weight – 125 lbs.

EAHC* and EFHC



With Union Hub



With Threaded Hub

Mounting Strap



Mounting strap can be furnished to fasten luminaire hangers to mounting surface, independent of conduit straps. To order, add suffix S294 to EAHC or EFHC Cat. No.

Suspension Attachment

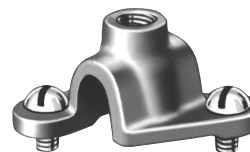

EAHC and EFHC hangers can be furnished with a loop fastened to the top of the body to suspend luminaire and conduit from vertical support rods or horizontal span wires. The loop will take a wire or cable with a maximum diameter of ⅜". The boss on top of the loop is tapped ⅜"-16 to accept a threaded rod. To order, add suffix S1 to Cat. No.

Ordering Information:

Hub Size	Luminaire Stem Size	Threaded Hub for Luminaire Stem Cat. #	Union Hub for Luminaire Stem Cat. #
EAHC*			
¾	½	EAHC2701	EAHC2601
	¾	EAHC2702	EAHC2602
1	½	EAHC3701	EAHC3601
	¾	EAHC3702	EAHC3602
EFHC			
¾	½	EFHC2701	EFHC2601
	¾	EFHC2702	EFHC2602
1	½	EFHC3701	EFHC3601
	¾	EFHC3702	EFHC3602

Dimensions

In Inches:

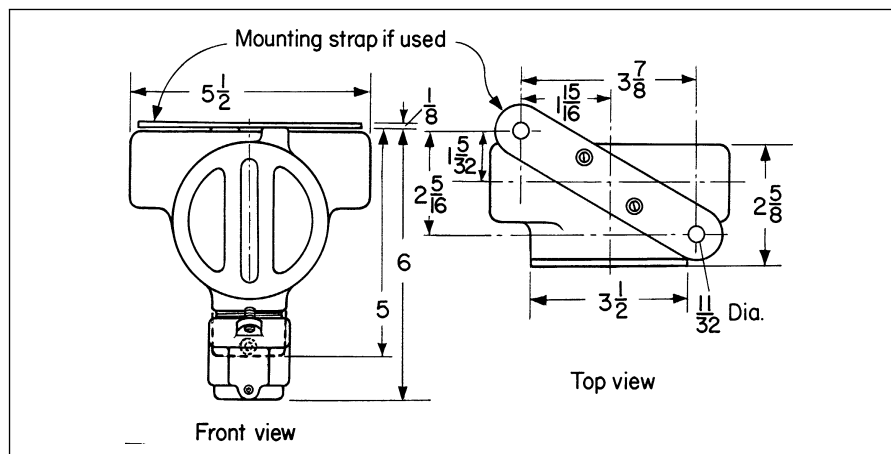

*EAHC only.

7L

EFH Flexible Cushion Luminaire Hangers

For Pendant Mount

Cl. I, Div. 1 and 2, Groups C, D
 Cl. II, Div. 1, Groups E, F, G
 Cl. II, Div. 2, Groups F, G
 Cl. III

Explosionproof
 Dust-Ignitionproof

7L

Applications:

EFH Flexible Cushion Luminaire Hangers are used in hazardous locations:

- Where a luminaire must hang more than 12" from its supporting junction box (as required by NEC Article 501 and CEC Part I Section 18)
- To assure that luminaires hang plumb and will swing freely if accidentally struck; prevents damage to luminaire, stem, and supporting outlet box
- To provide a cushion support, prolonging lamp life and protecting the luminaire from shock and vibration; for luminaires weighing up to 65 lbs.

Features:

- Complies with NEC Article 501 and CEC Part I Section 18
- Free swinging in any direction through an angle of 15 degrees from perpendicular
- Weight of luminaire is supported by a high strength brass bellows and a stainless steel cushioning spring
- Two part assembly consisting of luminaire hanger cover and CPS12 outlet box; provides a wide variety of conduit arrangements; a set-screw locks the conduit stem in place

Certifications and Compliances:

- NEC/CEC:
 - Class I, Groups C, D
 - Class II, Groups E, F, G
 - Class III
- UL Standard: 1203
- CSA Standard: C22.2 No. 30

Standard Materials:

- *Feraloy*[®] iron alloy

Standard Finishes:

- Electrogalvanized and aluminum acrylic paint

Size Ranges:

- Conduit hubs – 3/4" with 3/4" to 1/2" reducers
- Luminaire stem – 1/2" and 3/4"
- Luminaire weight – 65 lbs. max.



EFHX

Body Hub Size*	Luminaire Stem Size	With Mtg. Feet Cat. #
1/2 and 3/4	1/2	EFHX111
1/2 and 3/4	3/4	EFHX221

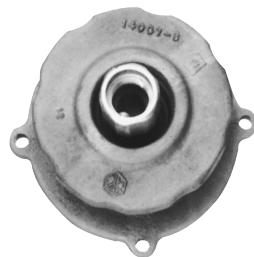

Cushion Luminaire Hanger Only

Stem Size	Cat. #
1/2	EFH01
3/4	EFH02

Dimensions In Inches:

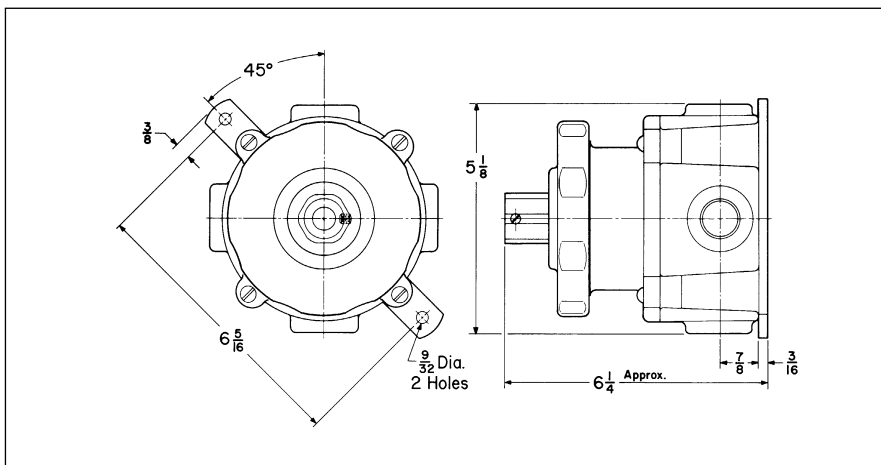

*Furnished with four 3/4" standard taper tapped, integrally bushed hubs. Each hub as a 3/4" to 1/2" reducer. Three hubs are plugged.

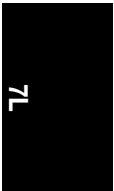

7L Condulet® Conduit Outlet Boxes with Covers

Cl. I, Div. 1 & 2, Groups C, D
 Cl. II, Div. 1, Groups E, F, G
 Cl. II, Div. 2, Groups F, G
 Cl. III

Explosionproof
 Dust-Ignitionproof

Applications:

CPS Series Conduit Outlet Boxes are installed in conduit systems in hazardous areas to:

- Protect conductors in threaded rigid conduit
- Act as pull and splice boxes
- Change conduit direction
- Interconnect lengths of conduit
- Act as luminaire hangers with hub covers
- Provide access to conductors for maintenance and future system changes

Features:

CPS Conduit Outlet Boxes have:

- Two types of cover:
 - Blank for splice or pull box use
 - Threaded hub for mounting luminaires
- Wide, accurately machined body and cover mating surfaces, to ensure flame-tight joint
- Blind tapped holes for cover screws to further ensure flame-tightness
- Removable mounting feet for flush or surface mounting to wall or ceiling

Certifications and Compliances:

- NEC/CEC:
 - Class I, Groups C, D
 - Class II, Groups E, F, G
 - Class III
- UL Standard: 1203
- CSA Standard: C22.2 No. 30

Standard Materials:

- Feraloy® iron alloy

Standard Finishes:

- Electrogalvanized and aluminum acrylic paint

Options:

Description

Corro-free™ epoxy enamel

Suffix
 (information available on request)

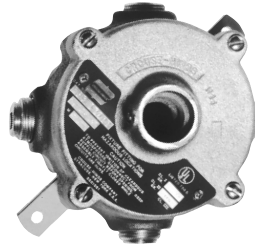

Box with Hub Cover

Hub Size	Cover	Cat. #
1/2 and 3/4	1/2	CPS12021
1/2 and 3/4	3/4	CPS12022



Box with Blank Cover

Hub Size	Cat. #
1/2 and 3/4	CPS12026



Body

Hub Size*	Cat. #
1/2 and 3/4	CPS12



Hub Covers

Hub Size	Cat. #
1/2	CPS021
3/4	CPS022

*Furnished with four 3/4" standard taper tapped, integrally bushed hubs. Each hub has a 3/4" to 1/2" reducer. Three hubs are plugged.

Dimensions In Inches:

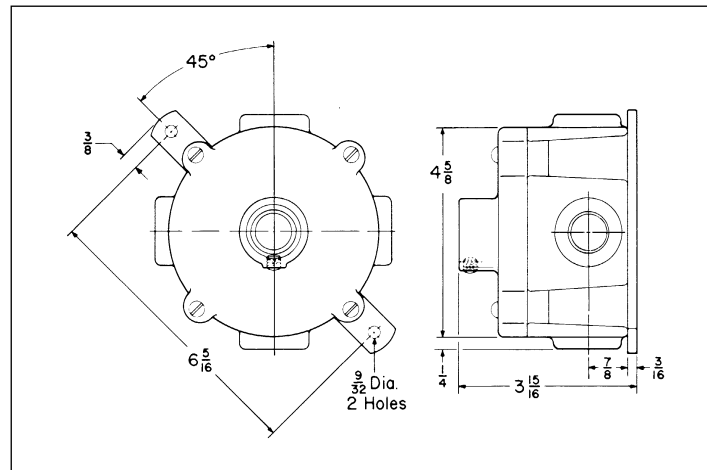

7L

GUA Series Outlet Bodies and Luminaire Hanger Covers

Cl. I, Div. 1 & 2, Groups C, D Explosionproof
 Cl. II, Div. 1, Groups E, F, G Dust-Ignitionproof
 Cl. II, Div. 2, Groups F, G
 Cl. III

7L

Applications:

GUA, GUF and GUJ Outlet Bodies are used:

- With luminaire canopies, union hub and nipple covers for mounting EVA, EVM, EVLP, and EVF luminaires

Features:

- A threaded cover opening in the side of the canopy permits access to the interior for making splices or taps
- The luminaire with its conduit stem and canopy is wired before installation, which eliminates wire twisting when the canopy is screwed into the outlet body
- Union hub covers permit the cover to be screwed into the body without twisting wire leads
- All covers have set-screws to lock the conduit stem or EC series flexible luminaire support firmly to the cover

Certifications and Compliances:

- NEC/CEC:
 - Class I, Groups C, D
 - Class II, Groups E, F, G
 - Class III
- UL Standard: 1203
- CSA Standard: C22.2 No. 30

Standard Materials:

Outlet bodies:

- GUA Series – *Feraloy* iron alloy
- GUFX – copper-free aluminum

Luminaire hanger covers:

- GUA068 – *Feraloy* iron alloy
- GUA0687, GUA0672 – copper-free aluminum

Standard Finishes:

- *Feraloy* iron alloy – electrogalvanized and aluminum acrylic paint
- Copper-free aluminum – natural

Options:

Description	Suffix
Finish – <i>Corro-free</i> ™ epoxy enamel.....	S752

Size Ranges:

- Bodies – 1/2" to 1" hubs
- Canopies – 1/2", 3/4" and 1 1/4" luminaire stem
- Union hub and nipple covers – 1/2" and 3/4" luminaire stem



GUA

Hub Size (In.)	Cat. #
1/2	GUA160
3/4	GUA260
1	GUA360



GUAT

Hub Size (In.)	Cat. #
1/2	GUAT160
3/4	GUAT260
1	GUAT360



GUAC

Hub Size (In.)	Cat. #
1/2	GUAC160
3/4	GUAC260
1	GUAC360



GUAX

Hub Size (In.)	Cat. #
1/2	GUAX160
3/4	GUAX260
1	GUAX360



GUAL

Hub Size (In.)	Cat. #
1/2	GUAL160
3/4	GUAL260
1	GUAL360

Dimensions In Inches:

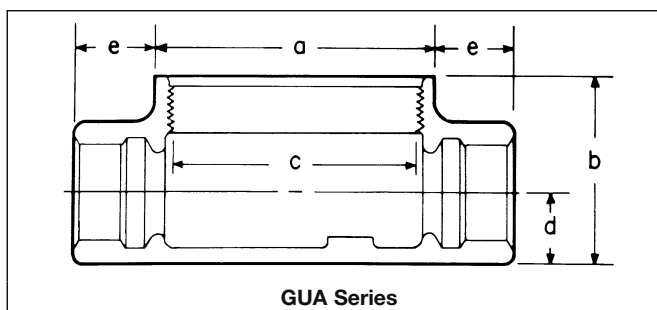

Hub Size	a	b	c	d	e
1/2	3 1/2	2	3	5/8	7/8
3/4	3 1/2	2	3	3/4	7/8
1	3 1/2	2 5/16	3	7/8	1



GUA Series Outlet Bodies and Luminaire Hanger Covers

Cl. I, Div. 1 & 2, Groups C, D Explosionproof
 Cl. II, Div. 1, Groups E, F, G Dust-Ignitionproof
 Cl. II, Div. 2, Groups F, G
 Cl. III

GUFX

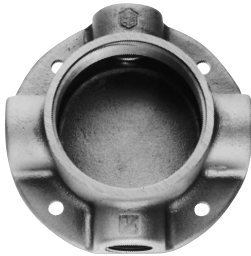

Hub Size	Cat. #
1/2	GUFX160
3/4	GUFX260

Dimensions In Inches:

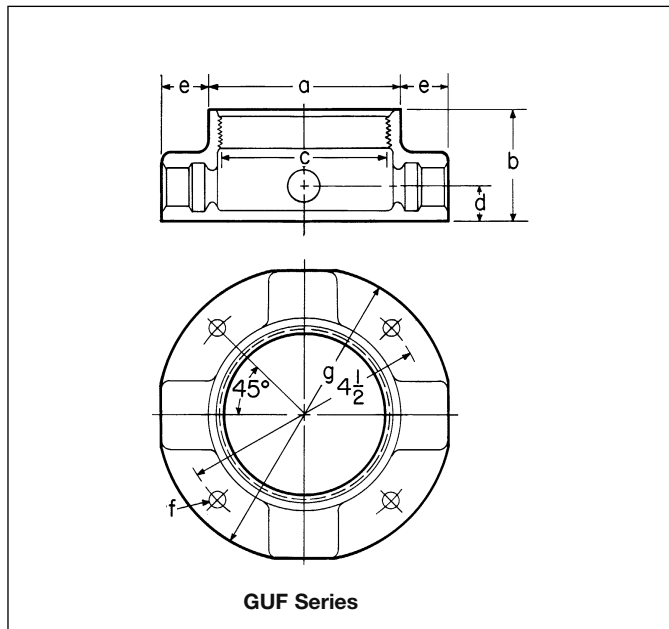

Hub Size	a	b	c	d	e	f	g
1/2	3 1/2	2	3	5/8	7/8	5/16	5 3/8
3/4	3 1/2	2	3	3/4	7/8	5/16	5 3/8
1	3 1/2	2 3/8	3	7/8	1	5/16	5 3/8

Luminaire Hanger Covers

For GUA and GUF Series Junction Boxes



Nom. Dia. Cover Opening	Luminaire Stem Size	Luminaire Canopies Cat. #	Luminaire Union Hub Cat. #	Covers Nipple Covers Cat. #
3	3/4	GUA068	GUA0687	GUA0672

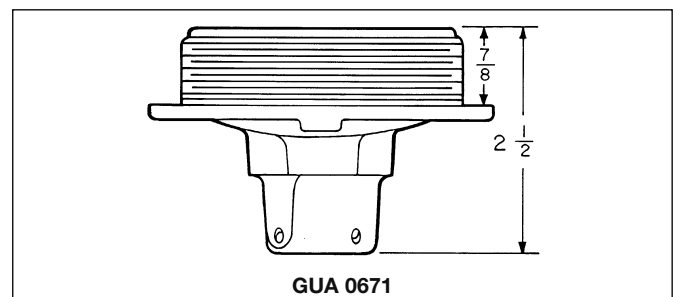
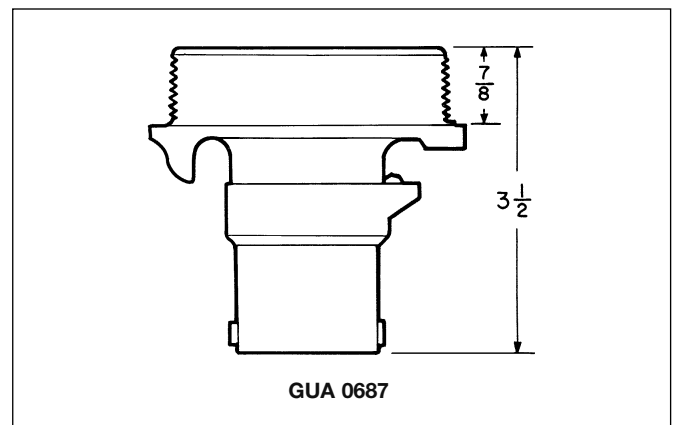
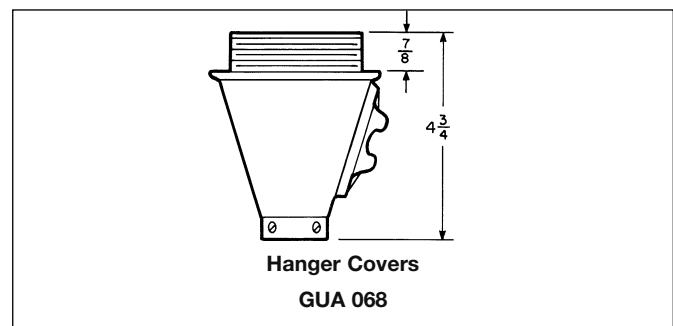

7L

UNR Adjustable Luminaire Hangers; COUP Locking Couplings

For Pendant Mount

Cl. I, Div. 1 & 2, Groups C, D
 Cl. II, Div. 1, Groups E, F, G
 Cl. II, Div. 2, Groups F, G
 Cl. III

Explosionproof
 Dust-Ignitionproof

7L

Applications:

- UNR Adjustable Luminaire Hangers are used in hazardous areas to:
- Mount between a luminaire and its outlet box so that the luminaire can be adjusted within the range of 0 degrees to 90 degrees
 - Permit pendant type luminaires to illuminate vertical surfaces such as a control board
 - Hang luminaires plumb when the supporting outlet box is not horizontal

Features:

- The luminaire is nipped onto one end of the UNR, and the other end of the UNR is nipped into the support outlet box
- Set-screws are located on each end to lock the nipples in place to prevent loosening in relamping or from vibration
 - Adjustment of UNR to the angle setting needed provides for the desired angle of the luminaire
 - Degree markings are cast into the UNR
 - Two set-screws and a large stud and nut are provided, which are tightened to clamp the unit rigid

Certifications and Compliances:

- NEC:
 - Class I, Groups C, D
 - Class II, Groups E, F, G
 - Class III
- UL Standard: 1203

Standard Materials:

- *Feraloy* iron alloy

Standard Finishes:

- Electrogalvanized and aluminum acrylic paint

Size Ranges:

- Hub – 3/4"
- Luminaire weight – 125 lbs.

Dimensions In Inches:

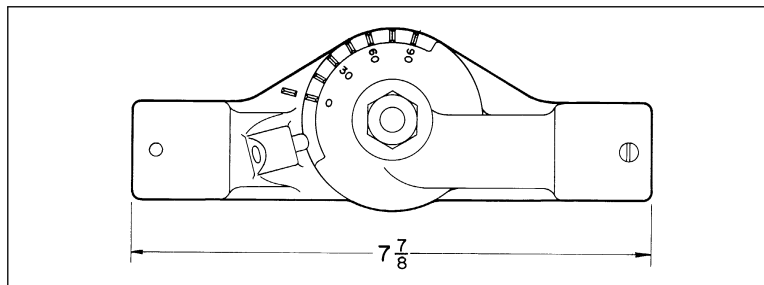

UNR Adjustable Luminaire Hanger

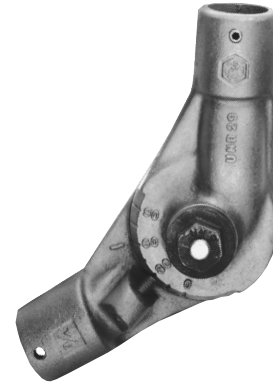

Hub Size	Angle Adjustment	Cat. #
3/4"	0° to 90°	UNR29

Applications:

- COUP Locking Couplings are used in both hazardous and non-hazardous areas to:
- Lock a luminaire conduit stem into a conduit hub to prevent the conduit stem from loosening when the luminaire is relamped and torque transferred to luminaire stem
 - Prevent loosening of luminaire stem due to vibration
 - Hang pendant type luminaires from standard cast outlet boxes which do not have set-screws in the hub where the luminaire stem is attached

Features:

- The large end is slipped over the cast hub and the set-screws tightened; the luminaire stem is slipped through the small end and threaded securely into the cast hub; the set-screws in the small end are then tightened, thereby preventing the stem from turning
- Permits support of luminaire from conduit hub of a hazardous location outlet body

Certifications and Compliances:

- UL Standard: 1203

Standard Materials:

- *Feraloy* iron alloy

Standard Finishes:

- Electrogalvanized and aluminum acrylic paint

Size Ranges:

- Hub size – 1/2" to 1"
- Stem size – 1/2" and 3/4"

COUP Locking Couplings



Hub Size	Stem Size	Cat. #
1/2"	1/2"	COUP101
3/4"	1/2"	COUP201
3/4"	3/4"	COUP202
1"	3/4"	COUP302



7L

7L

Description	Page No.
Application/Selection	see page 1182
Hand Lamps	
VS Series Incandescent	see page 1183
EVH Series Incandescent	see page 1184
EVH Series Fluorescent	see pages 1188–1189
Portable Floodlights	
RCDER Series Incandescent	see page 1185
EVP Series H.I.D.	see page 1187
Work Lights	
EVH Series Fluorescent	see pages 1188–1189



8L Portable Lighting

Hazardous and Non-hazardous Locations Application and Selection Quick Selector Chart

Applications:

Portable luminaires and accessories can be used:

- In areas made hazardous by the abnormal presence of flammable gases and vapors, combustible dusts, or easily ignitable fibers and flyings
- In areas where combustible dusts and flammable gases are present simultaneously
- In aircraft manufacturing and maintenance facilities, shipyards, paint spray booths, refueling depots, storage tank cleanings, railcar manufacturing and maintenance facilities, refineries, chemical and petrochemical plants, textile mills, grain elevators, pharmaceutical plants, sewage treatment plants, and wastewater treatment plants
- During plant 'shut downs' for maintenance and installation requirements
- In any adverse environment where portable lighting is preferred or required
- In locations where fixed lighting is not practical
- For task oriented lighting
- For emergency lighting applications
- When inspecting aircraft wing tanks, vats, process vessels, fuel tanks, etc. (hand lamps)

Considerations for Selection:

Environmental:

- What is the hazardous area classification (NEC/CEC) of the location in which the luminaires will be installed?
- What wattages and light source (ie. fluorescent) will provide the desired light levels?
- Type of luminaire required: handlamp, portable flood, or other special requirements

Table 500.8(C) Identification Numbers.

Deg. C	Maximum Temperature	Temperature Class (T Code)
	Deg. F	
450	842	T1
300	572	T2
280	536	T2A
260	500	T2B
230	446	T2C
215	419	T2D
200	392	T3
180	356	T3A
165	329	T3B
160	320	T3C
135	275	T4
120	248	T4A
100	212	T5
85	185	T6

Quick Selector Chart

Luminaire	NEC Hazardous Area Compliances	Lamp Watts	Volts
EVH Hand Lamp (Incandescent)	Cl. I, Groups C and D Cl. II, Group G Cl. III	100 max.	250 VAC
EVH Hand Lamp (Fluorescent)	Cl. I, Groups C and D Cl. II, Groups E, F, G Cl. III	13, 15	120, 220-50
EVP	Cl. I, Groups C and D Cl. II, Groups F and G Cl. III	35-150	120, 277, 347
RCDER	Cl. I, Groups C and D	150-500	
VS	Non-hazardous areas	100 max.	

8L

Incandescent Accessories

Applications:

The incandescent VS Portable Hand Lamps are used:

- In wet or corrosive locations to exclude moisture, dirt, corrosive chemicals, etc.
- Where an incandescent lamp of up to 100 watts is required in a portable hand lamp

Features:

- Enclosed and gasketed
- Flexible cord or cable is attached through a watertight gland in the handle
- Is of rugged construction
- Clamp type guard available
- Provision is made in the lamp receptacle for a third conductor to ground all non-current carrying metal parts

Certifications and Compliances:

- Weather resistant
- UL Standard: 298

(Note: CEC/CSA Certified VS Hand Lamps - Eaton's Crouse-Hinds Canada fixtures only).

Standard Materials:

- Handle – molded rubber
- Globe – clear, plain glass
- Guard – cast aluminum or steel wire

Standard Finishes:

- Handle – natural
- Guard – zinc plated

Size Ranges:

- Up to 100 watt, A-23 lamp
- 0.250 to 0.625 cord O.D.



(No Cable Included)

Globe Length	Max. Lamp Size	Cord Dia.	Rubber Cat. #
6 ⁷ / ₈ "	100W A-23*	0.125 to 0.625	VS30

Note: Furnished with clear globe, wire guard and 4 rubber bushings.

Glass Globes



Polycarbonate Globes



Description	Maximum Lamp Size	Cat. #
Clear Glass, (Heat Resisting)	100W, A-23 – 6 ⁷ / ₈ **	V63
Clear, Polycarbonate, Plain	75W, A-21**	V470

Guards



Description	Size	Cat. #
Steel Wire	6 ⁷ / ₈ " Globe	VS97

Lamp Receptacle (medium base)



Description	Size	Cat. #
Composition keyless	660W, 600V	GS156

Cord Gland Bushings



Description	Size	Cat. #
Rubber	0.125 to 0.250 Cord	BUSH92
	0.250 to 0.375 Cord	BUSH93
	0.375 to 0.500 Cord	BUSH94
	0.500 to 0.625 Cord	BUSH05

*Will take lamps with maximum dimensions of 6¹/₂" long and 2¹/₂" diameter.



8L EVH Portable Hand Lamp

Cl. I, Div. 1 & 2, Groups C, D
 Cl. II, Div. 1 & 2, Group G
 Cl. III
 Cl. I, Zone 1 IIB

Applications:

EVH106 is used:

- As a portable hand lamp in hazardous areas
- In inspecting aircraft wing tanks, vats, process vessels, fuel tanks, etc.

Features:

- Pressure connector terminals for portable cord
- Lightweight – 4¼" lbs.
- Designed for rough service – swivel hook, ease in relamping

Certifications and Compliances:

- NEC/CEC:
 - Class I, Division 1 and 2, Groups C, D – 100 watts max.
 - Class I, Zone 1 IIB
 - Class II, Division 1 and 2, Group G – 75 watts max.
 - Class III – 75 watts max.
- UL Standard: 781
- CSA Standard: C22.2 No. 137

Standard Materials:

- Guard and globe holder – copper-free aluminum
- Handle – molded phenolic composition
- Globe – glass, heat- and impact-resistant

Standard Finishes:

- Natural

Size Ranges:

- #16 – 3 type SO cord/cable is to be used (not supplied)

Capacity Ranges:

- 50 to 100 watt, A-21
- Max. volts – 250 VAC

Temperature Performance Data: (based on 40°C Ambient)

Class I, Groups C, D	T3C
Class II, Group G	T3C
Class III	T3C



Ordering Information

Cat. #	Type	Cord Dia.
EVH106	Model M10	0.375 to 0.625

Replacement Parts

Description	Cat. #
Guard and globe assembly	EVH606
Handle assembly (including lampholder)	EVH607
Cord connector assembly	EVH605
Lampholder only	EVH:05-279-A

8L

Note: See Section 2P of this catalog for suitable male plug.

Incandescent

Applications:

RCDER Portable Incandescent Luminaires provide general illumination in locations having hazardous atmospheres, such as:

- Oil refineries
- Oil and gasoline loading docks
- Aircraft servicing docks and shelters
- Distilleries
- Paint manufacturing plants
- Pumping stations
- Other Class I, Groups C and D locations

Features:

- Wheel base
- Carrying handle
- Adjustment allows rotation of 75° vertically
- Locking screws hold housing firmly in position
- Door which threads into housing includes heat- and impact-resistant lens; door has notches or projections for ease of removing or tightening
- Factory-sealed

Certifications and Compliances:

- NEC/CEC:
RCDER – Class I, Division 1 and 2, Groups (C), D; Class I, Zone 1 II(B) A (see photometric data listing)
- UL Standard: 844
- CSA Standard: C22.2 No. 137 (RCDER-6 only)

(Note: CEC/CSA Certified RCDER6 - Eaton's Crouse-Hinds Canada luminaires only).

Temperature Performance Data: (based on 40°C Ambient)

	150W	300W	500W
RCDER-6	T3B	T2B	
RCDER-10			T3C

Standard Materials:

- Body – copper-free aluminum
- Lens – glass, heat- and impact-resistant

Standard Finishes:

- Natural

Size Ranges:

- Take cable with O.D. of 0.375" to 0.500"

Capacity Ranges:

- RCDER-6 – 150 watt, PAR38 or R40; 300 watt, R40 (medium base)
- RCDER-10 – 500 watt, PAR64 (Ext. Mog End Prong)

Ordering Information:

After identifying the hazardous area, select the model of luminaire required for that area. Then from the photometric data, select appropriate Cat. No. based on type of mounting desired (Example: RCDER-10 No. 47283A).

RCDER-6



Cat. No. 44655B

RCDER-10

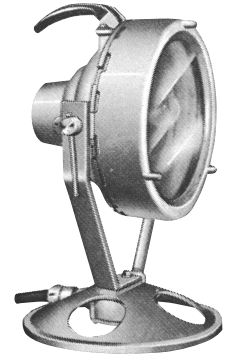

Cat. No. 47283A



8L Portable Mounted Lights

Photometric Data Dimensions and Weights

RCDER Photometric Data:

Lamp Watts and Type	Location	Beam Spread		Beam Lumens	Av. Max. Candle Power
		Hor.	Vert.		
RCDER-6					
150 Watt PAR38 Flood	Class I, Groups C, D (Zone 1 IIB)	60°	60°	1690	4000
150 Watt PAR38 Spot		28°	28°	1200	11500
300 Watt R40 Flood	Class I, Groups D (Zone 1 IIA)	123°	123°	3200	1950
300 Watt R40 Spot		60°	60°	3100	8900
RCDER-10					
500 Watt, PAR64 (500 PAR64/NSP)	Class I, Group D	19°	14°	3000	110000
500 Watt, PAR64 (500 PAR64/MFL)		35°	19°	3300	37000
500 Watt, PAR64 (500 PAR64/WFL)	(Zone 1 IIA)	55°	32°	3400	13000

Dimensions In Inches:

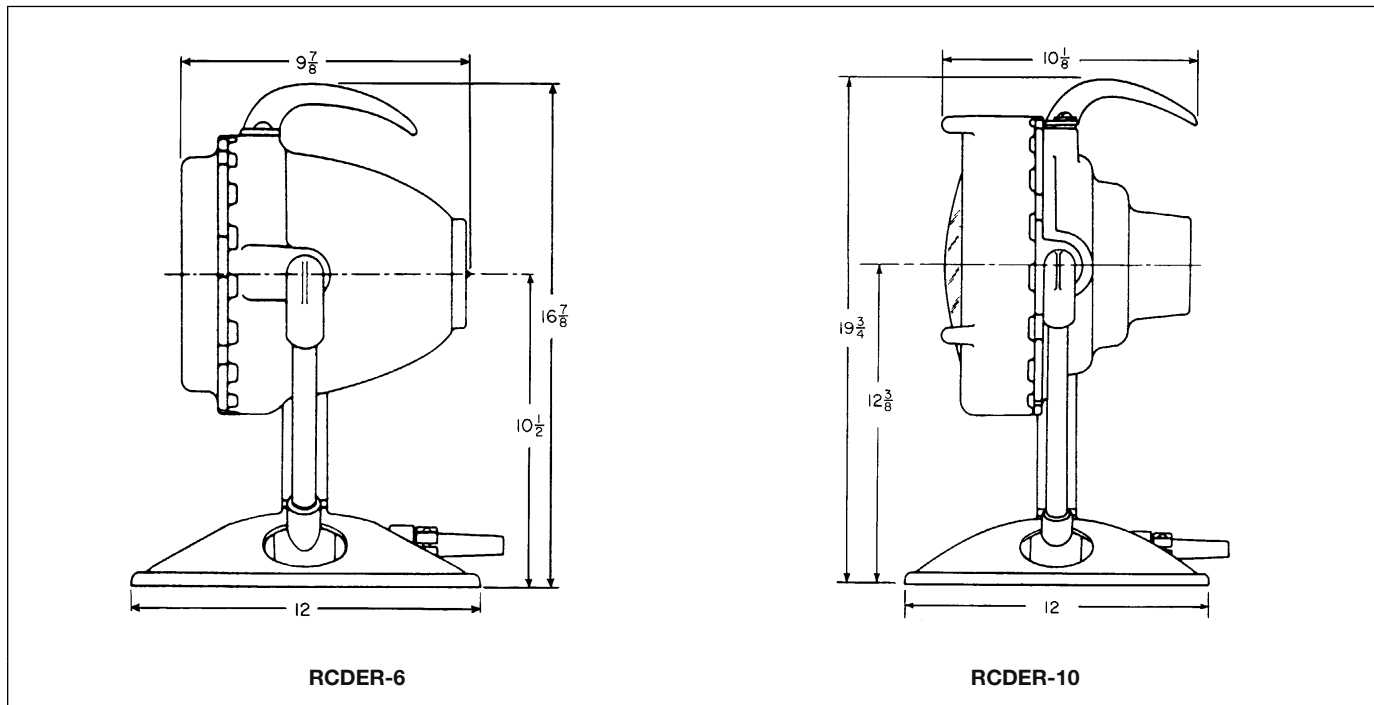

Fixture Weights:

	Cat. #	Lbs. (Net)
RCDER-6	44655	26.0
RCDER-10	47283	25.0

EVP Portable H.I.D. Floodlight

Cl. I, Div. 1 & 2, Groups C, D
 Cl. II, Div. 1 & 2, Groups F, G
 Cl. III
 Cl. I, Zone 1 IIB
 Wet Locations
 Marine Locations

8L

Applications:

The EVP Portable H.I.D. Floodlight† is suitable for maintenance or emergency lighting:

- In areas made hazardous by the presence of flammable gases and vapors, combustible dusts, or easily ignitable fibers and flyings
- In aircraft manufacturing and maintenance facilities, shipyards, refueling depots, storage tank cleaning, railcar manufacturing and maintenance facilities, refineries, chemical and petrochemical plants, textile mills, grain elevators and pharmaceutical plants, printing operations, wastewater, and sewage treatment plants
- In any adverse environment where portable lighting is preferred or required
- In locations where lighting is not practical
- For task oriented lighting

Certifications and Complies:

- EVP and EVPG
- NEC/CEC:
 - Class I, Division 1 & 2, Groups C, D
 - Class I, Zone 1 IIB
 - Class II, Division 1 and 2, Groups F, G
 - Class III
 - Wet Locations
 - Marine Locations
- UL Standards: 781, 595, 1572
- CSA Standard: C22.2 No. 137, No. 12

Standard Materials:

- Housing – copper-free aluminum
- Wheel base – spun aluminum
- Handle – plastic rib covered aluminum
- Reflector – aluminum
- O-ring gasket – Nitrile rubber

Electrical Ratings:

High pressure sodium – (medium base)

- 70, 100, & 150 watt
- 120 volt 60 Hz

Metal Halide – (double end)

- 70 watt
- 120, 277 & 347 volt; 60 Hz

Key Features Benefits

- | | |
|--|---|
| <ul style="list-style-type: none"> • Strong spun aluminum wheel base • Sturdy hand knob • Plastic rib covered handle • Aluminum specular reflector • Tempered, 3/4" thick cover glass • Nitrile rubber O-ring gasket • Strain relief clamps • Pre-wired, factory-sealed 100' of 16/3 type SOW cord supplied • Lightweight (25 lbs.) • Fixture housing has a safety yellow finish | <ul style="list-style-type: none"> • Provides stability, allows fixture to be hung on a wall or lowered in an inverted position • Tightens to hold position for steady illumination and easy aiming • Firm, non-slip grip for transporting fixture • Directs intense beam for better visibility • Heavy duty service • Excellent sealing for use in wet locations • Provides extra protection against cord damage • Saves on installation time and maintenance costs • Easy to handle when transporting • Highly visible for safety precautions |
|--|---|



Ordering Information:

Cl. I, Div. 1, Groups C, D Cl. II, Div. 1, Group F	Cat. #	Cl. I, Div. 1, Groups C, D Cl. II, Div. 1, Groups F, G Cl. III	Cat. #
70 watts HPS, 120 volts	EVP4070	100 watts HPS, 120 volts	EVPG4100
100 watts HPS, 120 volts	EVP4100	70 watt MH, 120 volts	EVPG9070
150 watts HPS, 120 volts	EVP4150*	70 watt MH, 277 volts	EVPG9070/277
70 watt MH, 120 volts	EVP9070	70 watt MH, 347 volts	EVPG9070/347
70 watt MH, 277 volts	EVPG9070/277		
70 watt MH, 347 volts	EVPG9070/347		

Note: Fixtures for grain dust applications have a special limiting device to prevent the fixture head from being positioned in an upright position limiting dust build-up.

Temperature Performance Data:

Cat. #	Max. Ambient °C	Class I, Division 1		Class II, Division 1	
		T-Rating	Groups	T-Rating	Groups
EVP4070	40	T4A	C, D	T3	F
EVP4100	40	T4A	C, D	T3	F
EVP4150	25	T3C	C, D	—	—
EVP9070	40	T4	C, D	T3	F
EVPG4100	40	T4A	C, D	T3C	F, G
EVPG9070	40	T4	C, D	T4	F, G

Fixture Weight:

- 25.5 lbs.

Photometric Data:

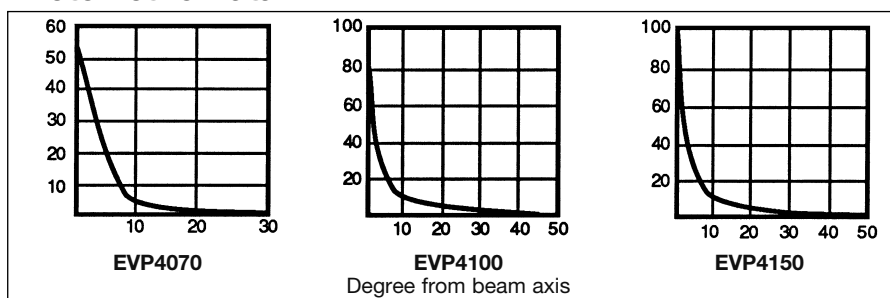

Dimensions: 12 1/2" D x 13 1/8" W x 15 5/8" H

†EVP fixtures are not supplied with plug.

*Class II not available.

8L EVH Fluorescent Hand Lamps & Work Lights

Cl. I, Div. 1 and 2, Groups C, D
 Cl. II, Div. 1, Groups E, F, G
 Cl. II, Div. 2, Groups F, G
 Cl. III
 Cl. I, Zone 1 IIB

Applications:

Portable hand lamps and work lights can be used:

- In areas made hazardous by the presence of flammable gases and vapors, combustible dusts, or easily ignitable fibers and flyings
- In aircraft manufacturing and maintenance facilities, shipyards, refueling depots, storage tank cleaning, railcar manufacturing and maintenance facilities, refineries, chemical and petrochemical plants, textile mills, grain elevators, pharmaceutical plants, sewage treatment plants, and wastewater treatment plants
- During plant 'shut downs' for maintenance and installation requirements
- In any adverse environment where portable lighting is preferred or required
- In locations where fixed lighting is not practical
- For task oriented lighting
- For emergency lighting applications
- When inspecting aircraft wing tanks, vats, process vessels, fuel tanks, etc.

Features:

- Built-in metal reflector which eliminates glare and blinding, focusing all light on subject
- Protected by patented shock absorbers to withstand rough usage
- Enclosed ballast, remote from light source for easier handling and maneuverability
- Special rubber compound bumper guards and end caps combined with cast guard and metal rods, protecting against damage from falling objects, bumping, or dropping
- Luminaires come complete with lamp(s) and cord
- The new EVH2625E and EVH2650E incorporate an electronic ballast in the handle for efficiency, cool operation, and easy handling

Certifications and Compliances:

- NEC: Fluorescent Work Lights (15 watt units)
 Class I, Division 1 and 2, Group D
 Class I, Zone 1 IIB
 Class II, Division 1, Groups E, F, G
 Class II, Division 2, Groups F, G
 Class III
- NEC: Fluorescent Hand Lamps (13 and 26 watt units)
 Class I, Division 1 and 2, Groups C, D
 Class II, Division 1, Groups E, F, G
 Class II, Division 2, Groups F, G
 Class III
- FM: Classification 3615
- CSA: C22.2

Standard Materials:

- Body and inline ballast unit – aluminum
- Tube shield – annealed glass
- Bumper guards – rubber

Standard Finishes:

- Aluminum body – white epoxy (hand lamps)
- Aluminum body – natural (work lights)
- Inline ballast unit – natural
- Rubber bumper guards – safety yellow

Options:

Description

An isolated ballast is available on the EVH 13 Watt hand lamps for additional protection

Suffix

IB

Size Ranges:

- Supplied with 18 / 3 SOW cord (25 ft or 50 ft)

Electrical Ratings:

- 13 to 26 Watts
- Max. volts 220VAC



Temperature Performance Data: Based on 40°C Ambient Temperature

Cat. #	Class I, Div. 1		Class II, Div. 1	
	T-Rating	Groups	T-Rating	Groups
EVH1525	T5	D	T5	E, F, G
EVH1550	T5	D	T5	E, F, G
EVH1325	T5	C, D	T5	E, F, G
EVH1350	T5	C, D	T5	E, F, G
EVH2625	T3	C, D	T3	E, F, G
EVH2650	T3	C, D	T3	E, F, G
EVH1325 IB	T5	C, D	T5	E, F, G
EVH1350 IB	T5	C, D	T5	E, F, G
EVH2625E	T6	C, D	T6	E, F, G
EVH2650E	T6	C, D	T6	E, F, G

Ordering Information:

EVH Fluorescent Work Lights

Line Voltage	Watts	Cord Length (ft.)	Lamp Type	Cat. #
60 Hz				
120	15	25 ft.	F15T8	EVH1525
120	15	50 ft.	F15T8	EVH1550

EVH Fluorescent Hand Lamps (with Magnetic Ballast in Cord)

Line Voltage	Watts	Cord Length (ft.)	Lamp Type	Cat. #
60 Hz				
120	13	25 ft.	F13TT	EVH1325
120	13	50 ft.	F13TT	EVH1350
120	26	25 ft.	F26DTT	EVH2625
120	26	50 ft.	F26DTT	EVH2650
50 Hz				
220	13	25 ft.	F13TT	EVH1325/220 50
220	13	50 ft.	F13TT	EVH1350/220 50
220	26	25 ft.	F26DTT	EVH2625/220 50
220	26	50 ft.	F26DTT	EVH2650/220 50

EVH Fluorescent Hand Lamps (with Electronic Ballast in Handle)

Line Voltage	Watts	Cord Length (ft.)	Lamp Type	Cat. #
60 Hz				
120	26	25 ft.	CF26DD/E/841	EVH2625E
120	26	50 ft.	CF26DD/E/841	EVH2650E

Crouse-Hinds
by E.T.N

EVH Fluorescent Hand Lamps & Work Lights

8L

Dimensions In Inches:

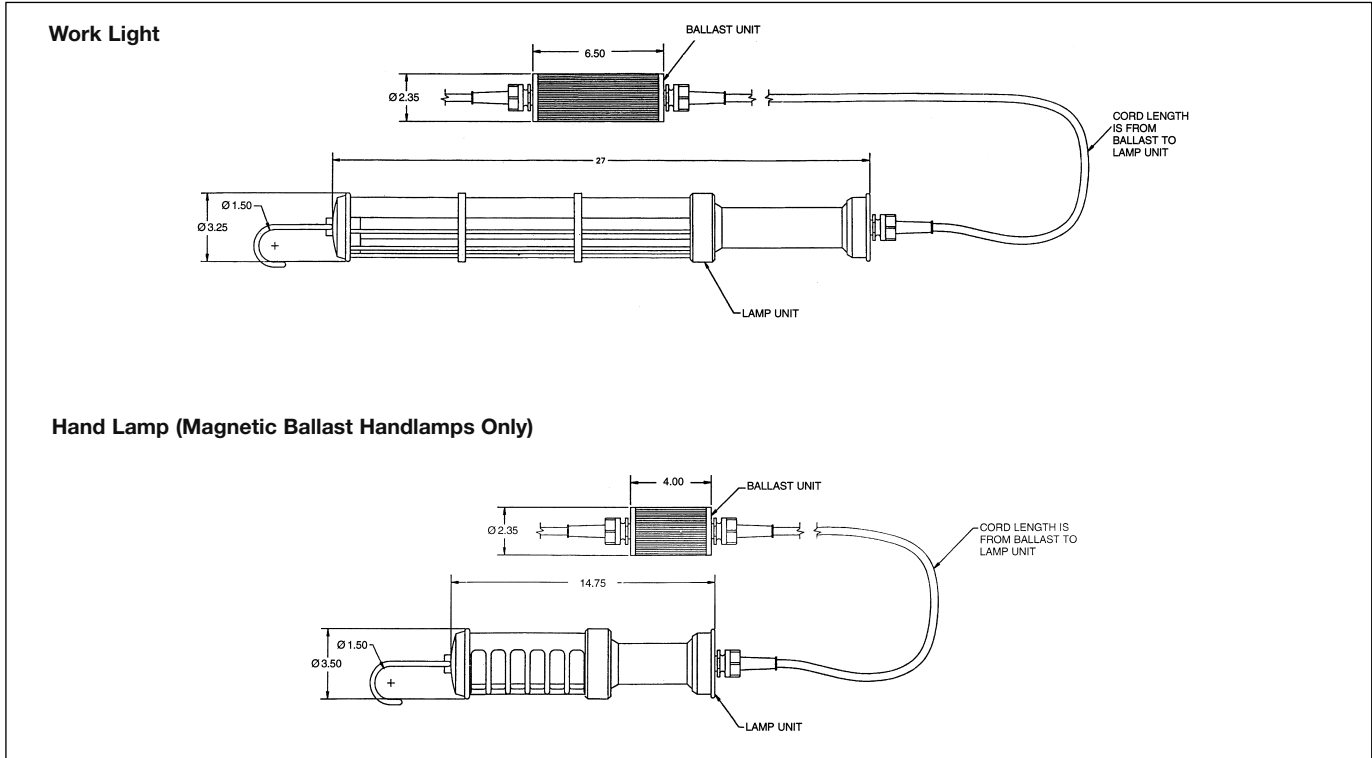

8L



Exit Signs and Emergency Luminaires Hazardous and Non-hazardous

9L

Description	Page No.
Exit Signs	
EXL Series	see pages 1192–1193
EVLPF(B)-EXD	see page 1194
DMVF(B)-EXD	see page 1195
Ex-Lite	see page 1207
CCH UX Series	see page 1208
Light-Pak™ – Emergency Lighting Systems	
ELPS Series	see page 1196
N2LPS Series	see pages 1198–1200
Remote Luminaire Heads	
EVLA	see page 1196
N2RF	see pages 1198–1200
Compact Fluorescent Emergency Luminaires	
CPMVFB	see pages 1201–1202
DMVFB	see pages 1203–1204
EVL PFB	see pages 1205–1206

9L

9L EXL Explosionproof Exit Sign

Cl. I, Div. 1 & 2, Groups C, D
 Cl. I, Zone 1 IIB
 Cl. II, Div. 1, Groups E, F, G

Factory-sealed

Applications:

EXL Exit Signs are used:

- In locations deemed hazardous due to the presence of flammable vapors or gases, or combustible dusts
- In any building or enclosed area where people work – where illuminated exit signs are required
- To provide distinct, highly visible exit marking
- To indicate the direction of travel to exits

Features:

- Two incandescent lamps (not included) wired in parallel – to provide extra margin of light source reliability
- Solid state circuit for extended lamp life in AC units
- Six inch red letters on white acrylic sign panel make word "exit" stand out boldly and clearly
- Edge lighting characteristic of sign panel makes visibility excellent at all lighting levels
- Factory-sealed explosionproof housing
- Pendant, wall, and end bracket mounts provide universal installation options
- Impact-resistant acrylic sign panel needs no guard – makes cleaning easy
- Internal rectifier extends lamp life beyond 1,000-hour rated life – reduces relamping cost
- Relamping tool provided

Certifications and Complies:

- NEC:
 - Class I, Groups C, D
 - Class II, Groups E, F, G
- UL Standard: 844
- NFPA Life Safety Code No. 101-1991

Standard Materials:

- Body – copper-free aluminum
- Sign panel – acrylic

Conduit Entrance:

- 3/4" hubs

Lamp Wattage:

- Two 60 watt, 60T10 clear lamps for AC units
- Two 25 watt, 25T10 clear lamps for DC units
- Lamps not included with luminaire

Electrical Ratings:

- 120VDC or 120VAC operation

Temperature Performance Data:

(for both AC & DC operation):

Ambient Temp. (°C)	Class I (C, D) Class II (E, F, G)	Supply Wire °C
25	T3C	150°C
40	T3C	

Ordering Information:

When ordering an EXL Series Exit Sign, you will need to specify:

- (A) Voltage (120VAC or 120VDC)
- (B) Mounting (Wall, End Bracket, or Pendant)
- (C) Exit Sign Designation

All units come standard with 3/4" hubs and exit signs with red lettering and white background. Complete catalog numbering is as follows:

EXL (A) 2 (B) (C)	
(A) Voltage:	120VAC..... leave blank 120VDC D
(B) Mounting:	Wall..... 1 End Bracket..... 2 Pendant 3
(C) Exit Sign Designation:	
A	Single Face (Wall Mount)
AA	Double Face (End Bracket & Pendant)
AB	Double Face, one side arrowhead right, the other no arrowhead (End Bracket & Pendant)
AC	Double Face, one side arrowhead left, the other no arrowheads (End Bracket & Pendant)
AD	Double Face, one side arrowhead both ends, the other no arrowheads (End Bracket & Pendant)
B	Single Face, arrowhead right (Wall Mount)
BC	Double Face, one side arrowhead right, the other arrowhead left (End Bracket & Pendant)
BD	Double Face, one side arrowhead both ends, the other arrowhead right (End Bracket & Pendant)
C	Single Face, arrowhead left (Wall Mount)
CD	Double Face, one side arrowhead both ends, the other arrowhead left (End Bracket & Pendant)
D	Single Face, arrowhead both ends (Wall Mount)
DD	Double Face, both sides arrowhead both ends (End Bracket & Pendant)



Pendant Style



End Bracket Style

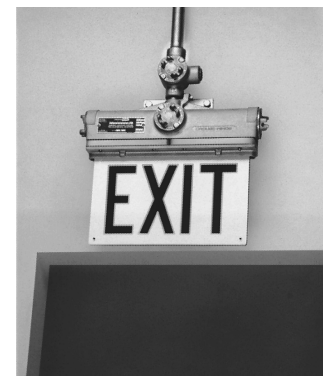

Wall Style

Mounting Type	Sign Panel Description	Hub Size (In.)	AC Cat. #	DC Cat. #
Wall	Single face	3/4	EXL21A	EXLD21A
End Bracket	Double face	3/4	EXL22AA	EXLD22AA
Pendant	Double face	3/4	EXL23AA	EXLD23AA

Options:

Description

- Exit signs with green lettering on white background..... **Suffix GN**
- Unit provided with epoxy powder coat..... **S752**
- 277VAC – (Order ECT413 Transformer Separately)

9L

**Factory-sealed
Dimensions**

**Dimensions
In Inches:**

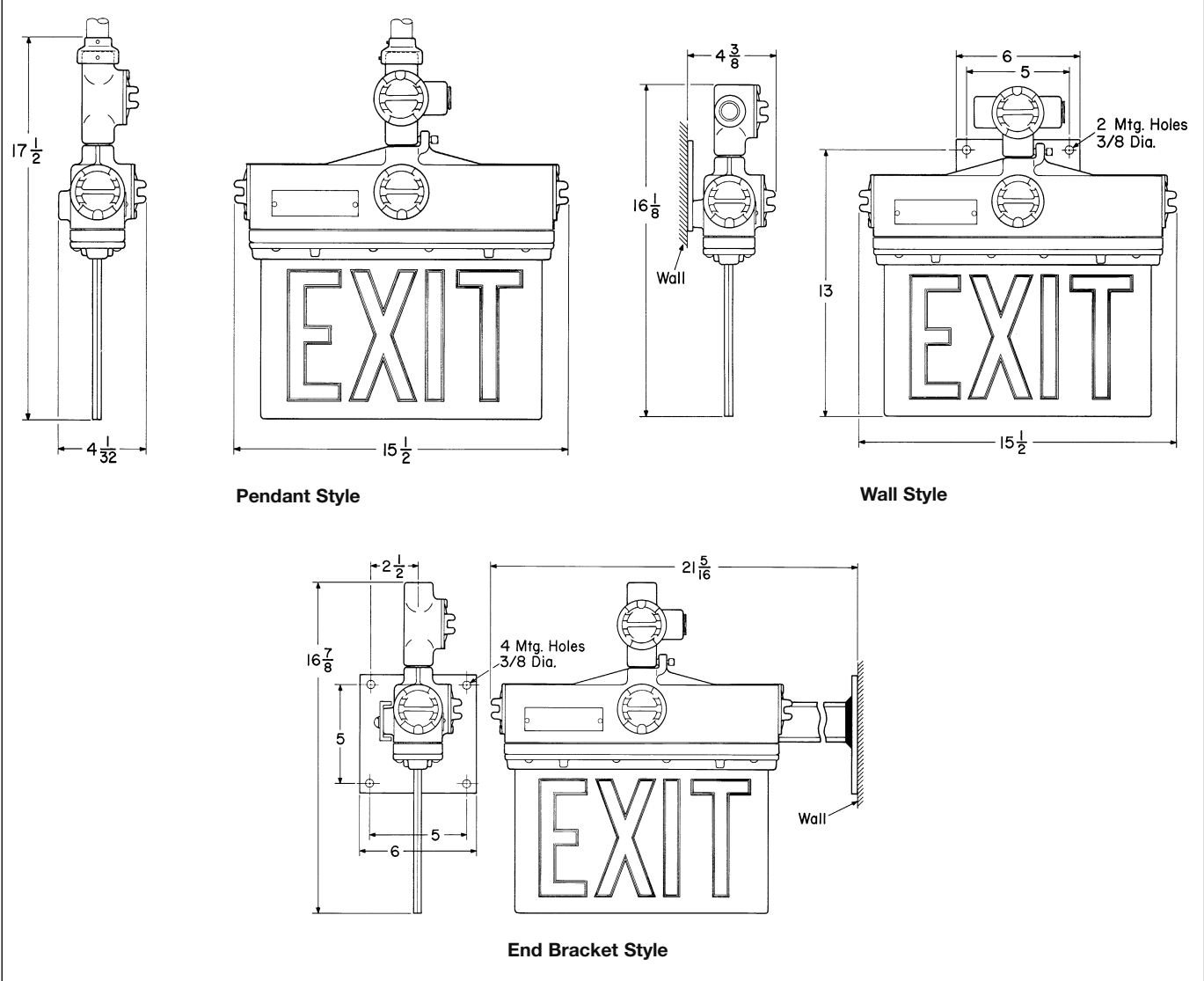

9L

9L EVLPF(B) – Exit Sign Fluorescent Luminaire

Cl. I, Div. 1, Groups B (suffix GB), C, D
 Cl. I, Zone 1, Groups IIB + H₂
 (GB suffix), IIB
 Cl. II, Div. 1, Groups E, F, G; Class III,
 Simultaneous Presence

Marine & Wet
 Locations
 3, 3R, 4, 4X;
 IP66

Applications:

EVLPF(B)-EXD Exit Signs are used:

- In any building or enclosed area where people work – where illuminated exit signs are required
- To provide distinct, highly visible exit marking
- To indicate the direction of travel to exits
- In locations deemed hazardous due to the presence of flammable vapors, gases, or combustible dusts

Features and Benefits:

- Six inch red letters on white glass sign panel make the word "EXIT" stand out boldly and clearly
- Lightweight copper-free aluminum housing with powdered epoxy finish
- All exterior hardware is corrosion-resistant stainless steel
- Three mounting arrangements: pendant, ceiling, and wall bracket
- Integral ballast
- High power factor (90%+) ballasts
- Easier assembly, installation, and maintenance
- Outdoor, hose down, marine and corrosive environments suitable
- Ideal for adverse environments typical of industrial facilities
- Ground wire for safety
- Optional battery back-up for operation during power outage

Certifications and Compliances:

- NEC and CEC:
 - Class I, Division 1, Groups B (GB suffix), C, D
 - Class I, Zone 1, Groups IIB + H₂ (GB Suffix), IIB, IIA
 - Class II, Class III & Simultaneous Presence (Class I and Class II)
- UL Standards:
 - 844 Hazardous (Classified) Locations
 - 1598 Luminaires
 - 1598A Marine Locations
- CSA Standards:
 - C22.2 No. 137

Standard Materials:

- Mounting modules, cover, ballast housing, globe holder – copper-free aluminum
- Globe – heat- and impact-resistant glass
- Exterior hardware – stainless steel

Standard Finishes:

- Copper-free aluminum – *Corro-free™* powdered epoxy

Options:

Description	Suffix
Group B suitability	GB
Factory assembled with lamps	FA



Ratings (Electrical/Size):

Sources/wattage:

- 52W (2-26W lamps)
- 120-277V, 50-60 Hz
- 120V, 60 Hz
- 347V, 60 Hz

Conduit entries:

- 3/4", 1" NPT – pendant, wall bracket, ceiling

About the Battery:

- Bodine fluorescent battery pack ballasts are UL component recognized
- Sealed, maintenance-free, high temperature nickel cadmium
- Solid state chargers are sealed inside the ballast case
- 90 minute illumination time
- 10-year life expectancy
- 2-year full warranty
- During emergency use 1 lamp has continuous operation
- Red indicator light indicates the battery is charging
- Wiring instructions for a "Push-to-Test" button is supplied with the luminaire

Energy Savings:

- Less wattage used with compact fluorescent lamps compared to equivalent incandescent lamps providing the same light output

Ordering Information:

Mounting Type	Supply Voltage Volts/Hertz	Fluorescent Cat. #	Fluorescent with Battery Back-up Cat. #
Pendant	120-277V / 50-60 Hz	EVL PFA02520/UNV EXD	EVL PFBA02520/UNV EXD
	120V / 60 Hz (Canada) 347V / 60 Hz	EVL PFA02520/347 EXD	EVL PFBA02520/120CAN EXD EVL PFBA02520/347 EXD
Ceiling	120-277V / 50-60 Hz	EVL PFCX02520/UNV EXD	EVL PFBCX02520/UNV EXD
	120V / 60 Hz (Canada) 347V / 60 Hz	EVL PFCX02520/347 EXD	EVL PFBCX02520/120CAN EXD EVL PFBCX02520/347 EXD
Wall	120-277V / 50-60 Hz	EVL PFBX02520/UNV EXD	EVL PFBBX02520/UNV EXD
	120V / 60 Hz (Canada) 347V / 60 Hz	EVL PFBX02520/347 EXD	EVL PFBBX02520/120CAN EXD EVL PFBBX02520/347 EXD

DMVF(B) – Exit Sign Fluorescent Luminaire

Cl. I, Div. 2; Groups A, B, C, D
Restricted Breathing Cl. I,
Div. 2 & Zone 2 (Suffix S826)
Certified for IEC Zone 2
(Suffix S826TB)

Cl. II, Groups E, F, G,
Cl. III & Simultaneous Presence
Marine & Wet Locations
3, 3R, 4X; IP66

9L

Applications:

DMVF(B) Exit Signs are used:

- In any building or enclosed area where people work
- Where illuminated exit signs are required
- To provide distinct, highly visible exit markings
- To indicate the direction of travel to exits
- In locations deemed hazardous due to the presence of flammable vapors or gases, or combustible dusts

Features:

- Six inch letters on white glass sign panel make the word "exit" stand out boldly and clearly
- Housings made of die-cast copper-free aluminum (less than 0.4 of 1% copper) for strength and resistance to corrosion
- Mounting module equipped with integral hub set-screws for vibration resistance (ceiling and pendant mounts)
- Hubs are provided with an integral conduit stop and bushing to help prevent damage to field wiring during installation
- Epoxy powder finish and stainless steel external hardware for resistance to corrosion
- Long life gaskets which provide seals between mounting module, housing, and globe assembly
- Grounding wire for safety
- Cool operating design
- Optional emergency battery back-up operation during power outage

About the Battery:

- Bodine fluorescent battery pack ballasts are UL component recognized
- Sealed, maintenance-free, high temperature nickel cadmium
- Solid state chargers are sealed inside the ballast case
- 90 minute illumination time
- 10-year life expectancy
- 2-year full warranty
- During emergency use 1 lamp has continuous operation
- A red indicator light indicates the battery is charging
- Wiring instructions for a "Push-to-Test" button is supplied with the fixture

Energy Savings:

- Less wattage used with compact fluorescent lamps compared to equivalent incandescent lamps providing the same light output

Certifications and Compliances:

- NEC and CEC:
 - Class I, Division 2, Groups A, B, C, D
 - Class II, Class III & Simultaneous Presence (Class I, Division 2 and Class II)
 - Class I, Zone 2
- IEC:
 - Zone 2 Ex nR IIC
- UL Standards:
 - 844, 2279 Hazardous (Classified) Locations
 - 1598 Luminaires
 - 1598A Marine Luminaires
- CSA Standards:
 - C22.2 No. 137
- IEC Standards:
 - 60079-15

Standard Materials:

- Ballast housings and mountings – copper-free aluminum (less than 0.4 of 1%)
- Exterior hardware – stainless steel
- Globe – heat- and impact-resistant internally fluted glass

Standard Finishes:

- Aluminum – gray epoxy powder coat
- Krydon material – high reflectance white
- Stainless steel – natural

Options:

Description	Suffix
Lamps supplied with exit sign.....	S714
Top hat with stainless steel threaded insert.....	S806
Restricted breathing construction.....	S826
Class I, Division 2 & Zone 2 suitability	
Cooler operating temperatures (T-Numbers)	
Certified for IEC Zone 2.....	S826TB
Furnished with:	
Terminal Block	
Crimp Terminals	
Dedicated voltage ballasts (no MT, DT or TT)	

Electrical Rating Ranges:

- 52 Watt
- 120–277V, 50–60 Hz
- 120V, 60 Hz
- 347V, 60 Hz

Ordering Information:

Mounting Type	Supply Voltage Volts/Hertz	Fluorescent Cat. #	Fluorescent with Battery Back-up Cat. #
Pendant	120–277V / 50–60 Hz	DMVF2A052G/UNV EXD	DMVFB2A052G/UNV EXD
	120V / 60 Hz (Canada) 347V / 60 Hz	DMVF2A052G/347 EXD	DMVFB2A052G/120CAN EXD DMVFB2A052G/347 EXD
Ceiling	120–277V / 50–60 Hz	DMVF2C052G/UNV EXD	DMVFB2C052G/UNV EXD
	120V / 60 Hz (Canada) 347V / 60 Hz	DMVF2C052G/347 EXD	DMVFB2C052G/120CAN EXD DMVFB2C052G/347 EXD
Wall	120–277V / 50–60 Hz	DMVF2TW052G/UNV EXD	DMVFB2TW052G/UNV EXD
	120V / 60 Hz (Canada) 347V / 60 Hz	DMVF2TW052G/347 EXD	DMVFB2TW052G/120CAN EXD DMVFB2TW052G/347 EXD



9L ELPS Light-Pak™ Emergency Lighting System

Cl. I, Div. 1 & 2, Groups C, D
Cl. I, Div. 1 & 2, Groups B, C, D
(with suffix GB)
Cl. II, Div. 1, Groups E, F, G
Cl. III

Cl. I, Zone 1
Simultaneous Presence
Wet Locations
NEMA 3, 3R, 12

Applications:

ELPS Series Emergency Lighting Systems are used:

- To provide safe, reliable illumination indoors or outdoors to designated areas during failure or interruption of power to the normal lighting system
- In areas made hazardous by the presence of flammable gases and vapors, combustible dusts, or easily ignitable fibers and flyings
- In areas where corrosion, vibration, moisture, dirt, and rough usage may be encountered
- Where required by the National Electrical Code®, the Life Safety Code, or other codes
- In refineries, chemical and petrochemical facilities, grain processing, handling or storage facilities, manufacturing plants, wastewater treatment facilities, and other areas where safe, reliable, hazardous area emergency lighting is needed

Features:

- Compact factory-sealed luminaire assemblies are each furnished with a 12 watt tungsten-halogen lamp and inner reflector for appropriate photometrics in hazardous areas
- Luminaire assemblies are fully adjustable and lockable on two axes to provide flexible and consistent light aiming capabilities
- Luminaire lens ring is threaded for easy relamping and locks in place with hex head set-screw; will not loosen due to vibration
- Ground joint cover with external flange design permits large opening and easy access to internal components; stud bolts in diagonally opposite corners of body ease cover removal and installation
- Neoprene cover gasket seals out moisture for superior protection of internal components against wetness and corrosion
- Lightweight, compact size, and mounting feet ease installation and allow placement in confined areas
- Two 1" NPT drilled and tapped conduit openings, with plugs, are standard, for choice of top or bottom feed
- Factory-installed PUSH-TO-TEST pushbutton enables easy testing of system
- MAIN POWER ON pilot light indicates AC power is being supplied to the battery charger; pilot light jewel is threaded for easy lamp replacement
- Stainless steel drain minimizes moisture collection; stainless steel breather with aluminum cap provides ventilation, minimizes moisture collection

- CID 101 corrosion inhibitor device is provided with each ELPS system to help protect electrical components and connections
- Rugged, long-life, maintenance-free, nickel cadmium battery provides 30 watts of power for the required 1½ hours
- Solid state battery charger for long life and reliable service prevents deep discharge by automatically disconnecting luminaires from battery
- Terminal block facilitates field wiring connections
- Instruction sheet and maintenance record card provided with unit in a protective plastic envelope
- A time delay is standard; time delay is preset at factory for 5 minute delay but can be field set for 5 seconds or 15 minutes, thus allowing HID type lamps time to restrike and reach desired illumination levels
- Solid state battery charger will accept 120, 220/240 or 277 VAC, 50/60 Hz

Certifications and Complies:

- NEC:
 - Class I, Groups B, C, D
 - Class II, Groups E, F, G
 - Class III
 - Simultaneous Presence
- NEMA: 3R, 12 (ELPS power supply)
- Suitable for wet locations (EVLA fixtures)
- Marine (EVLA fixtures)
- UL Standard:
 - 844 – Electric Luminaire – Hazardous Locations
 - 924 – Emergency Lighting and Power Equipment
 - 1203 – Explosionproof and Dust-Ignitionproof Electrical Equipment
- Life Safety Code:
 - Section 5-9 (Emergency Lighting)
- Suitable for Wet Locations
- NEMA 3, 3R, 12
- Marine

Standard Materials:

- Power supply enclosure and luminaire assembly – copper-free aluminum (less than 0.4 of 1% copper)

Standard Finishes:

- Power supply enclosure and fixture assemblies – powder coat epoxy paint finish

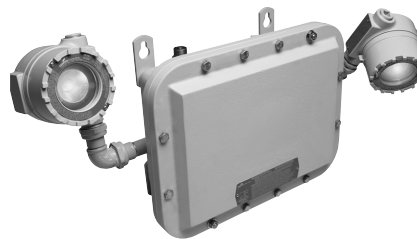

Electrical Ratings:

- Power Supply:
 - Input:
 - 120, 220/240, 277 VAC, 50 or 60 Hz
 - 0.5 Amps Maximum
 - Output:
 - 12 VDC
 - UL listed for 28 watts for 1½ hours at 0° – 40°C
- Luminaires:
 - Voltage: 12 VDC
 - Lamp Type: #789, miniature Tungsten halogen, G4, 2-pin, 14 watt

Options:

Description	Suffix
Remote mounted lamp head and arm.....	EVLA12
Key operated disconnect switch as part of the ELPS502 emergency light system	S794
Keyless operated designated disconnect switch as part of the ELPS502 emergency light system	S854

Ordering Information:

Description	Cat. #
Standard unit with adjustable heads.....	ELPS502†
Replacement power interior, includes circuit board and battery pack	ELPS K50
Power supply	ELPS50†
Lamphead and arm	EVLA12†
Exit sign, double sided with EVI, red letters.....	ELPS502 EXD
Exit sign, double sided with EVI, green letters....	ELPS502 EXD GN
Exit sign, single or double sided with Group B EVA, red letters.....	ELPS502 EXD GB
Exit sign, single or double sided with Group B EVA, green letters	ELPS502 EXD GB GN
Exit sign, single sided with EVI, red letters.....	ELPS502 EXS
Exit sign, single sided with EVI, green letters.....	ELPS502 EXS GN

†Base unit comes standard with Class I, Division 1, Group B.

ELPS Light-Pak™ Emergency Lighting System

Temperature Performance Data
Photometric Data
Dimensions and Weights

9L

Temperature Performance Data:

Cat. #	Class	T-number
Maximum Ambient Temperature 55°C		
EVLA12	I	T4A
	II*	T3B
	III*	T3B
Maximum Ambient Temperature 40°C		
ELPS EVI		T3C
		T4
ELPS EVA		T3C
		T4

*For Class II and Class III applications, fixtures must not be aimed more than 30° above horizontal (see diagram below).

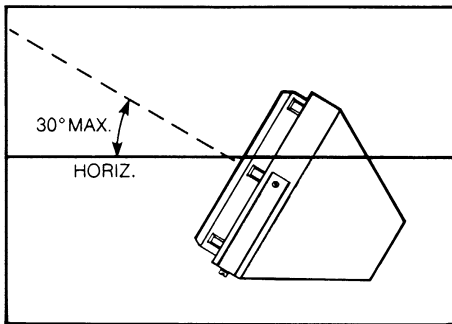

Photometric Data:

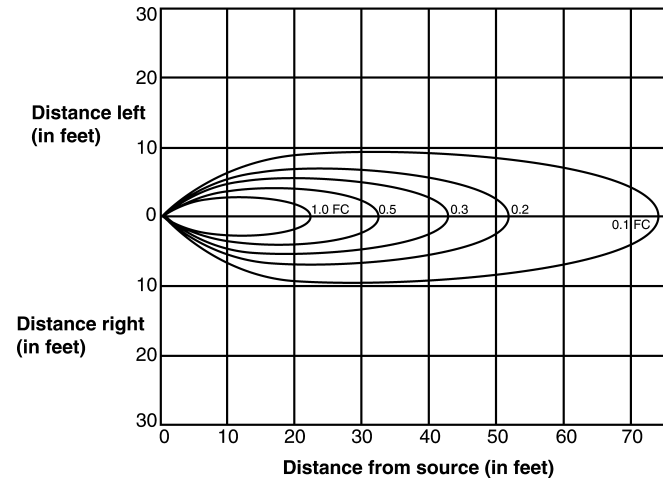

Dimensions

In Inches:

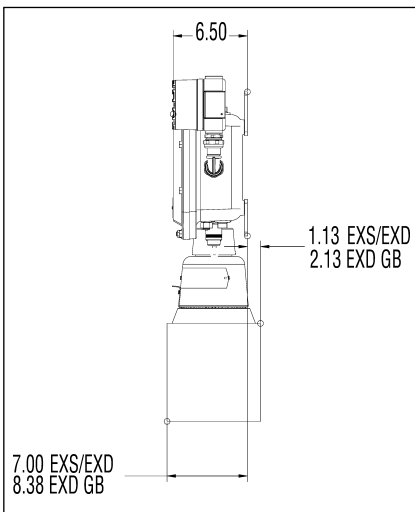
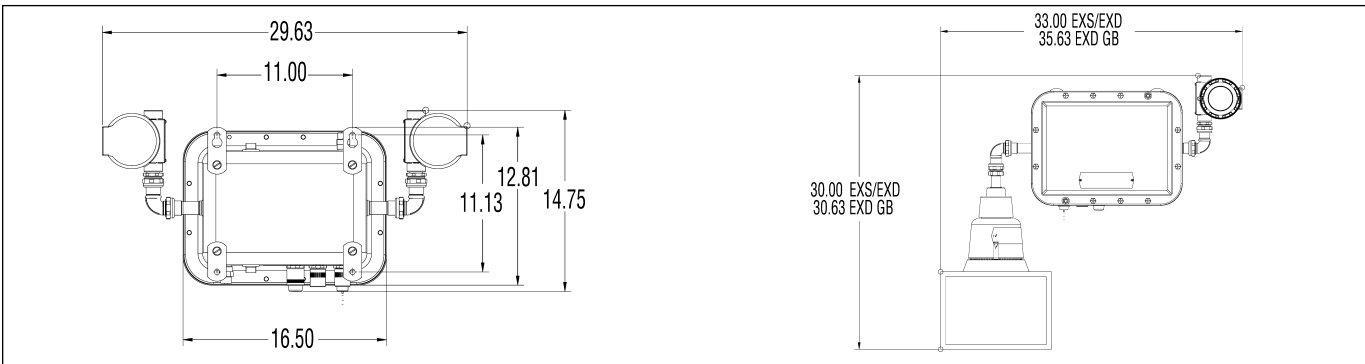

Unit Net Weights:

- ELPS502 complete emergency lighting system – 50 lbs.
- ELPS50 power supply – 40 lbs.
- EVLA12 luminaire assembly – 5 lbs.

Status Indication:

LED Status	Condition	Meaning of the Indication
	No light	AC power is removed from the circuit
•	Steady light (no blinking)	Fully charged
•	Light blinks once	Charging
••	Light blinks twice	Battery failure
•••	Light blinks three times	Circuit failure
••••	Light blinks four times	Lamp failure



9L N2LPS LIGHT-PAK™ Emergency Lighting System

Cl. I, Div. 2, Groups B, C, D
Cl. I, Zone 2
Cl. II, Div. 2, Groups F, G
Wet Locations, Marine
NEMA 3, 3R, 4X
Ambient 0°C to 55°C

Applications:

LED N2LPS Light-Pak™ emergency lighting systems are used:

- To provide reliable illumination for egress areas during failure or interruption of power to the normal lighting system
- In areas where flammable gases or vapors may become present due to abnormal, unusual, or accidental conditions
- In manufacturing plants, refineries, petrochemical and chemical plants, waste and sewage treatment facilities, oil terminals, food processing facilities, breweries, and other industrial manufacturing or process industry facilities subject to wet or corrosive conditions
- To illuminate machinery or panels during a loss of AC power
- Where moisture, dirt, dust, or corrosion will limit the life and reliability of ordinary emergency lighting systems
- Where required by the National Electrical Code®, the Life Safety Code® or other applicable codes
- Outdoor applications

Features:

- Compact, factory-assembled luminaire featuring LED lamps for improved lumen performance, on-time, and lamp life
- Nonmetallic, enclosed, and gasketed housing provides corrosion protection in the most extreme environments
- Durable and marine rated LED lamp head assemblies provide protection against water ingress, corrosion, and impact
- High temperature rated nickel cadmium battery for reliable operation up to 55°C ambient
- Solid state battery charger for long life and reliable battery operation prevents deep discharge by automatically disconnecting the battery from the luminaire
- Factory-installed "push-to-test" button
- Self-test, monitoring, and diagnostics reduce costly maintenance checks
- Remote luminaire head assemblies (one or two) are available for mounting of luminaire heads away from main power system
- Stainless steel drain minimizes moisture collection
- Standard battery disconnect switch (Krydon® unit)

Certifications and Complies:

NEC/CEC:

- Class I, Division 2, Groups B, C, D, Zone 2

UL Standards:

- 1598A (Supplemental Requirements for Luminaires for Installation on Marine Vessels)
- 924 (Emergency Lighting and Power Equipment)
- 844 (Electric Luminaires Hazardous Locations)

CSA Standards:

- C22.2 No. 141-M1985 unit equipment for emergency lighting
- C22.2 No. 137-M1981 non-incendive electrical equipment for use in Class I, Division 2 hazardous locations
- Life Safety Code NFPA101® – Section 5-9 (Emergency Lighting)
- Marine wet locations suitability, Type 4X

Standard Materials:

- Power supply and remote luminaire enclosures – Krydon® fiberglass-reinforced polyester
- LED lamp head assembly – epoxy powder coated stainless steel
- Exterior hardware – nylon, plastic coated, and stainless steel
- Cover gasket – Hypalon® synthetic rubber

Temperature Performance Data:

Based on 55°C ambient

Cat. #	Class I, Division 2	Class II, Division 1
N2LPS (all)	40°C - T5; 55°C - T4A	T6
N2RF (all)	T5	T6

Note: Ambient temperature at which the Light-Pak system is rated is 0°C to 55°C. Operation at temperatures outside this range will affect the battery life and/or charging performance.

Note: Battery time in emergency mode is 90 minutes.

National Electrical Code and Life Safety Code are registered trademarks of the National Fire Protection Association, Inc.

Noryl is a registered trademark of General Electric Company.



Electrical Ratings:

- Power supply –
Input: 120, 220, 230, 240, or 277 VAC, 50 or 60 Hz; 9 watts max.
Output: 18 watts max. at 12 VDC
- Luminaire heads –
Voltage: 12 VDC; Lamp: 3 watt LED
Total lumen output: 80

Unit Net Weights:

- N2LPS12222 – 16 lbs.
- N2LPS12220 – 12 lbs.
- N2RF1221 – 8 lbs.
- N2RF1222 – 9 lbs.

Options:

Description	Suffix
55°C suitabilityS904

9L

N2LPS LIGHT-PAK™ Emergency Lighting System

Cl. I, Div. 2, Groups B, C, D
Cl. I, Zone 2
Cl. II, Div. 2, Groups F, G
Wet Locations, Marine
NEMA 3, 3R, 4X
Ambient 0°C to 55°C

9L

Ordering Information:

Description	Cat. #
28 watt, 12 volt power supply assembly with two 3 watt LED lamp heads	N2LPS12222
28 watt, 12 volt stainless steel power supply assembly with two 3 watt LED lamp heads	N2LPS12222 SS
28 watt, 12 volt power supply assembly less luminaire heads	N2LPS12220*
Remote luminaire assembly with one 3 watt LED lamp head	N2RF1221*
Remote luminaire assembly with two 3 watt LED lamp heads	N2RF1222*
28 watt, 120V LED Light-Pak with single sided exit sign**	N2LPS12222/120 EXS DR0391734
28 watt, 277V LED Light-Pak with single sided exit sign**	N2LPS12222/277 EXS DR0391734
28 watt, 120V LED Light-Pak with double sided exit sign**	N2LPS12222/120 EXD DR0391734
28 watt, 277V LED Light-Pak with double sided exit sign**	N2LPS12222/277 EXD DR0391734

*Not cUL approved. UL Listed only.

**Exit sign operates in both normal and emergency mode.

Note: Up to four (4) remote LED lamp assemblies can be connected to the N2LPS12222. Up to six (6) remote LED lamp assemblies can be connected to the N2LPS12220.

Wire Sizing for Remote Installation:

For Copper Wire –

Running Distance† (ft.) Between Power Supply and Remote Luminaire

Wire Size	Load In Watts				Wire Size	Load In Watts			
	8	16	24	32		8	16	24	32
16 AWG	26	13	6	3	10 AWG	106	53	26	13
14 AWG	42	21	10	5	8 AWG	168	84	42	21
12 AWG	66	33	16	8	6 AWG	270	135	67	33

†Maximum distance to limit line voltage drop to 5%.

Dimensions (N2LPS):

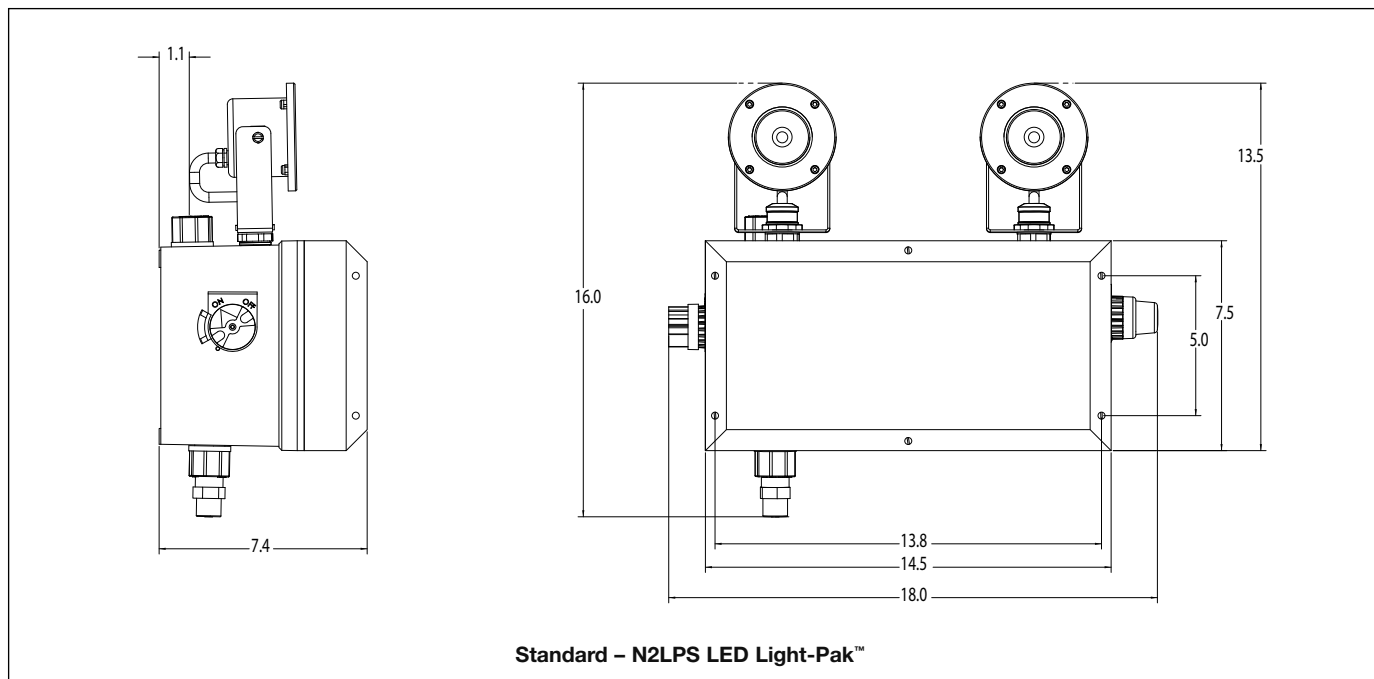

9L

9L N2LPS LIGHT-PAK™ Emergency Lighting System

Cl. I, Div. 2, Groups B, C, D
Cl. I, Zone 2
Cl. II, Div. 2, Groups F, G
Wet Locations, Marine
NEMA 3, 3R, 4X
Ambient 0°C to 55°C

Dimensions (N2LPS):

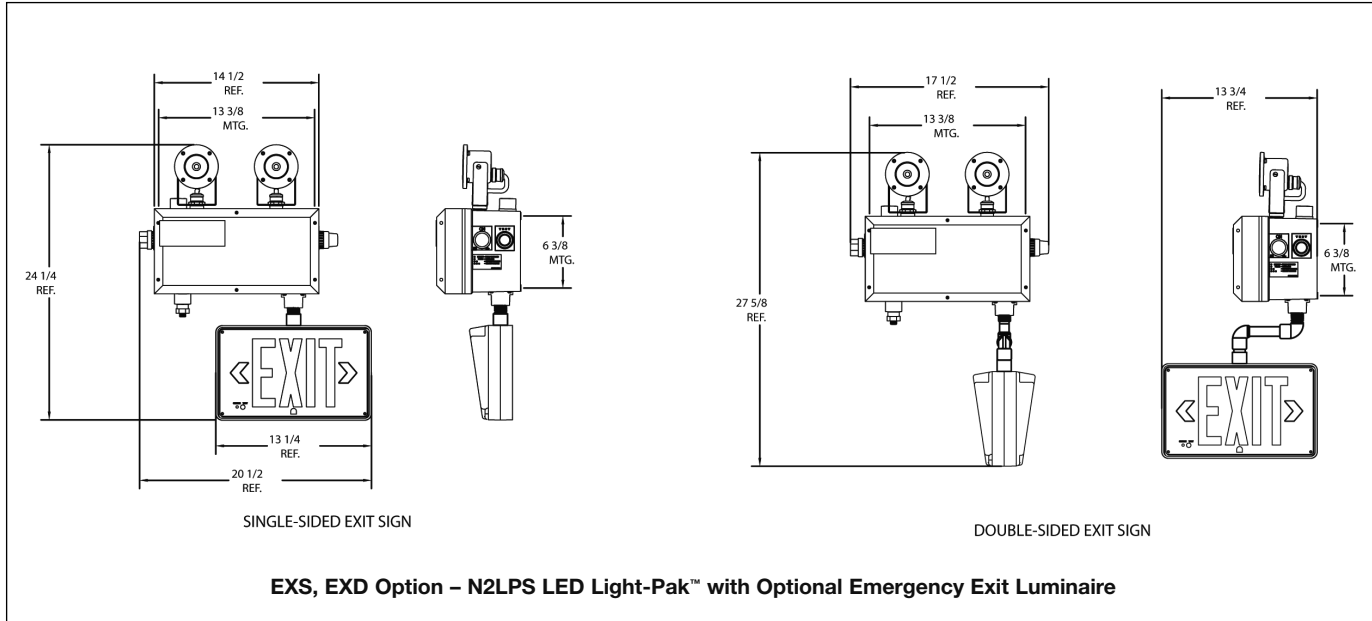

Dimensions (N2RF):

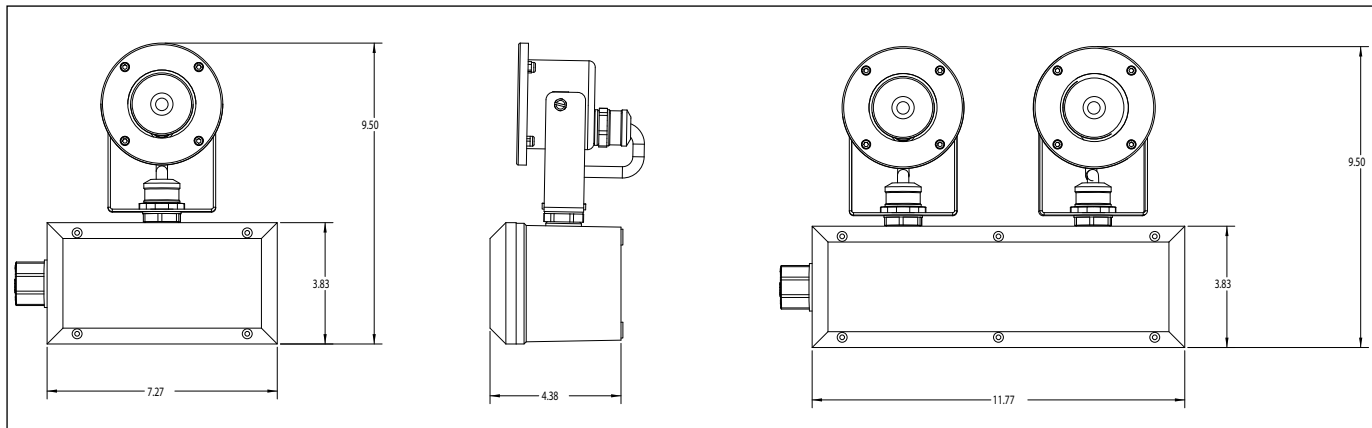

Detail Indication Logic:

Status Indication	Status Description	Status Definition
	No Light	AC Power Removed from Circuit
*	Steady Light (No Blinks)	Fully Charged
_	Light Blinks Once	Battery Charging
_	Light Blinks Twice	Battery Failure
_	Light Blinks Three Times	Circuit Failure

CPMVFB Emergency Compact Fluorescent

Continuous Operation Champ-Pak™ Luminaires

Cl. I, Div. 2, Groups A, B, C, D
 Restricted Breathing Cl. I, Div. 2
 & Zone 2 (Suffix S826)
 Certified for IEC Zone 2
 (Suffix S826TB)

Cl. II, Groups E, F, G; Cl. III &
 Simultaneous Presence*
 Marine & Wet Locations
 3, 3R, 4, 4X; IP66
 Emergency Lighting

9L

Applications:

- Where emergency lighting is required to permit workers in industrial areas to safely encounter their surroundings during power failures
- Where emergency egress lighting is required, such as: catwalks, walkways, tunnels, doorways, stairs, stairwells, ramps and aisles
- Indoor and outdoor wall mounting or vertical surface mounting where minimal luminaire depth is required in:
 - Manufacturing plants and heavy industrial facilities
 - Industrial process facilities such as refineries, chemical, petrochemical, pharmaceutical, and platforms
 - Waste or sewage treatment plants
 - Offshore, dockside, and harbor installations
- For security and safety lighting in industrial facilities for lighting of loading docks, tunnels, and stairways
- For marine, wet location, hose down, and corrosive environments

Features and Benefits:

- Unique compact shallow profile design mounts virtually anywhere
- Side hinged cover with two screw closing for easy installation and maintenance
- Gray Corro-free™ epoxy powder coat two-piece housing provides superior corrosion resistance
- Unique stainless steel wire guard accessory attaches without any additional hardware for easy installation and maintenance
- Glass refractor provides uniform light distribution to eliminate glare
- Silicon gaskets make luminaire suitable for NEMA 4X, marine environments
- High power factor ballasts (+90%) are standard, which allow more luminaires per circuit

Certifications and Compliances:

- NEC/CEC:
 - Class I, Division 2, Groups A, B, C, D
 - Class II, Class III & Simultaneous Presence
 - (Class I, Division 2 and Class II)
 - Class I, Zone 2
- IEC:
 - Zone 2 Ex nR IIC
- UL Standards:
 - 844, 2279 Hazardous (Classified) Locations
 - 1598 Luminaires
 - 1598A Marine Locations
- CSA Standards:
 - C22.2 No. 137
- IEC Standards:
 - 60079-15

*Consult Eaton's Crouse-Hinds.

Crouse-Hinds
 by **E.T.N**

Standard Materials:

- Luminaire housing and door frame assembly – copper-free aluminum
- External hardware – stainless steel
- Lens – heat- and impact-resistant refractor style glass
- Gaskets – silicon rubber
- Reflector – aluminum light sheet
- Wire guard – stainless steel

Standard Finishes:

- Aluminum – Corro-free™ epoxy powder coat
- Stainless steel – natural

Options:

Description	Suffix
Restricted breathing construction.....	S826
Class I, Division 2 & Zone 2 suitability	
Cooler operating temperatures (T-numbers)	
Certified for IEC Zone 2 (Suffix S826TB).....	S826TB
Furnished with:	
Terminal Block	
Crimp Terminals	
Dedicated voltage ballasts (no MT, DT or TT)	
Factory assembled with lamp installed.....	FA
Fused - projects ballast and capacitors against abnormal line conditions.....	S658
(Not for use in Canada)	
(Not for Marine use)	

Electrical Rating Ranges:

- 52 watts
- 120-277V, 50-60 Hz
- 120V, 60 Hz
- 347V, 60 Hz

About the Battery:

- Bodine fluorescent battery pack ballasts are UL component recognized
- Sealed, maintenance-free, high temperature nickel cadmium
- Solid state chargers are sealed inside the ballast case
- 90 minute illumination time
- 10-year life expectancy
- 2-year full warranty
- During auxiliary use 1 lamp has continuous operation
- A red indicator light indicates the battery is charging
- Wiring instructions for a "Push-to-Test" button is supplied with the fixture

Accessories:

Description	Cat. #
Stainless steel wire guard.....	P55



9L

9L

CPMVFB Emergency Compact Fluorescent

Ordering Information
Dimensions & Weights

Continuous Operation Champ-Pak™ Luminaires

Ordering Information:

Hub Size	Lamp Watts	Cat. # for use with ANSI Lamps
3/4 NPT	26	CPMVFB2W026

Standard Voltage Ballasts

Voltage Suffix	NEC/UL	CEC/CSA (cUL)	
	120-277V 50-60 Hz /UNV	120V/60 Hz /120CAN	347V 60 Hz /347

Dimensions

In Inches:

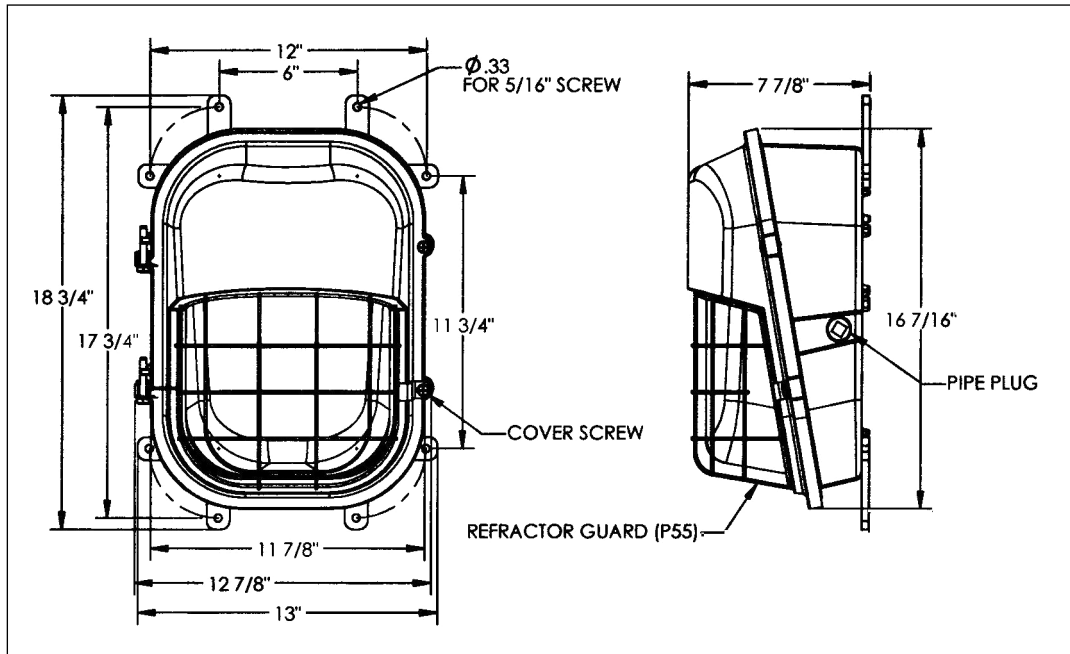

9L

Net Weights:

Luminaire Less Guard	18.6 lbs.
P55 Guard	0.5 lbs.

DMVFB Emergency Compact Fluorescent

Continuous Operation Champ® Luminaires

Cl. I, Div. 2, Groups A, B, C, D
 Restricted Breathing Cl. I,
 Div. 2 & Zone 2 (Suffix S826)
 Certified for IEC Zone 2
 (Suffix S826TB)

Cl. II, Groups E, F, G; Cl. III &
 Simultaneous Presence
 Marine & Wet Locations
 3, 3R, 4, 4X; IP66
 Emergency Lighting

9L

Applications:

DMVF Series Champ Lighting Luminaires are used:

- Where emergency lighting is required to permit workers in industrial areas to safely encounter their surroundings during power failures
- Where emergency egress lighting is required, such as: catwalks, walkways, tunnels, doorways, stairs, stairwells, ramps, and aisles
- In areas made hazardous by abnormal conditions resulting in the presence of flammable vapors or gases
- In areas made hazardous by the presence of combustible dusts
- Where combustible dusts and flammable vapors are present simultaneously
- In marine applications where water spray and corrosive atmospheres are considerations
- On installations where vibration and rough usage are problematic
- Where a cool, efficient light source is required
- In areas that require lamps to reach full illumination immediately
- In refineries, chemical and petrochemical facilities, grain processing, handling or storage facilities, manufacturing plants, wastewater treatment plants, sewage treatment plants, oil terminals, food processing facilities, breweries, and any other manufacturing or processing facility where safe, reliable hazardous area fluorescent or auxiliary lighting is needed

Standard Features:

- Housings made of die-cast copper-free aluminum (less than 0.4 of 1% copper) for strength and resistance to corrosion
- Mounting modules equipped with integral hub set-screws for vibration resistance (ceiling, pendant, and quad mounts)
- Hubs are provided with an integral conduit stop and bushing to help prevent damage to field wiring during installation
- Epoxy powder finish and stainless steel external hardware for resistance to corrosion
- Long-life gaskets which provide seals between mounting module, housing, and optical assembly
- Grounding wire for safety
- Cool operating design
- Optional stainless steel open bottom guard permits direct access to the globe for easy relamping
- Battery pack ballast for emergency lighting

Certifications and Compliances:

- NEC/CEC:
 - Class I, Division 2, Groups A, B, C, D
 - Class II, Class III & Simultaneous Presence (Class I, Division 2 and Class II)
 - Class I, Zone 2
 - Emergency Lighting
- IEC:
 - Zone 2 Ex nR IIC
- UL Standards:
 - 844, 2279 Hazardous (Classified) Locations
 - 1598 Luminaires
 - 1598A Marine Locations
 - 924 Emergency Lighting
- CSA Standards:
 - C22.2 No. 137
- IEC Standards:
 - 60079-15

Standard Materials:

- Ballast housings and mountings – copper-free aluminum (less than 0.4 of 1%)
- External hardware guards – stainless steel
- Reflectors – Krydon® fiberglass-reinforced polyester material
- Globe – heat- and impact-resistant internally fluted glass

Standard Finishes:

- Aluminum – gray epoxy powder coat
- Krydon material – high reflectance white
- Stainless steel – natural

Options:

Description	Suffix
• Restricted breathing construction.....	S826
• -Class I, Division 2 & Zone 2 suitability	
• -Cooler operating temperatures (T-numbers)	
• Certified for IEC Zone 2.....	S826TB
• -Furnished with: Terminal Block Crimp Terminals	
• Emergency operation only – Consult Eaton's Crouse-Hinds	
• Factory assembled with lamp installed.....	FA
• Fused – to protect ballast against abnormal line conditions (not for use in Canada) (not for marine use).....	S658
• Lamps supplied with luminaire...	S714
• Top hat with stainless steel threaded insert to attach ballast housing.....	S806
• TEFLON® coating on globe for increased shatter protection.....	S808



Electrical Rating Ranges:

- 52, 64, and 84 watts
- 120–277V, 50–60 Hz
- 347V, 60 Hz

Accessories:

(Order separately)

Description	Cat. #
Dome	RD739
30° Angle	RA739

Energy Savings

- Less wattage used with compact fluorescent lamps compared to equivalent incandescent lamps providing the same light output

About the Battery (DMVFB Units):

- Bodine fluorescent battery pack ballasts are UL component recognized
- Sealed, maintenance-free, high temperature nickel cadmium
- Solid state chargers are sealed inside the ballast case
- 90 minute illumination time
- 10-year life expectancy
- 2-year full warranty
- During auxiliary use 1 lamp has continuous operation
- A red indicator light indicates the battery is charging
- Wiring instructions for a "Push-to-Test" button is supplied with the fixture

9L

DMVFB Emergency Compact Fluorescent

Continuous Operation Champ® Luminaires

Cl. I, Div. 2, Groups A, B, C, D
 Restricted Breathing Cl. I,
 Div. 2 & Zone 2 (Suffix S826)
 Certified for IEC Zone 2
 (Suffix S826TB)

Cl. II, Groups E, F, G; Cl. III &
 Simultaneous Presence
 Marine & Wet Locations
 3, 3R, 4, 4X; IP66
 Emergency Lighting

DMVFB Series Fluorescent with Battery Back-Up with G303 Globe and P33 Guard Cat.

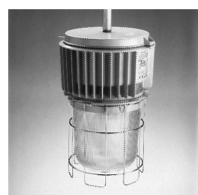

Mounting Style	Hub Size (In.)	Lamp Watts	Cat. #
Pendant Mount	3/4	52	DMVFB2A052GP
	1		DMVFB3A052GP
	3/4	64	DMVFB2A064GP
	1		DMVFB3A064GP
	3/4	84	DMVFB2A084GP
	1		DMVFB3A084GP

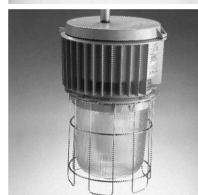

Flexible Pendant Mount	3/4	52	DMVFB2HA052GP
	3/4	64	DMVFB2HA064GP
	3/4	84	DMVFB2HA084GP



Ceiling Mount Thru-Feed	3/4	52	DMVFB2C052GP
	1		DMVFB3C052GP
	3/4	64	DMVFB2C064GP
	1		DMVFB3C064GP
	3/4	84	DMVFB2C084GP
	1		DMVFB3C084GP



Wall Mount Thru-Feed	3/4	52	DMVFB2TW052GP
	1		DMVFB3TW052GP
	3/4	64	DMVFB2TW064GP
	1		DMVFB3TW064GP
	3/4	84	DMVFB2TW084GP
	1		DMVFB3TW084GP

Note: For technical information on family trees, temperature performance data, dimensions, weights, and photometrics, refer to Series in Section 5L.

Quad-Mount	3/4	52	DMVFB25Q052GP
	3/4	64	DMVFB25Q064GP
	3/4	84	DMVFB25Q084GP

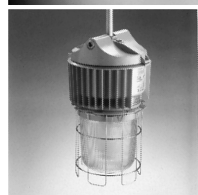

Stanchion Mount 25° Angle	1 1/2	52	DMVFBJ052GP
	1 1/2	64	DMVFBJ064GP
	1 1/2	84	DMVFBJ084GP



Stanchion Mount Straight	1 1/2	52	DMVFBP052GP
	1 1/2	64	DMVFBP064GP
	1 1/2	84	DMVFBP084GP



1. Catalog numbers are basic numbers. Voltage must be specified.

Standard Voltage Ballasts

1. Voltage Suffix	NEC/UL		CEC/CSA (cUL)	
	120-277V 50-60 Hz /UNV	120V/60 Hz /120CAN	347V 60 Hz /347	

EVL PFB Emergency Compact Fluorescent

Continuous Operation Low Profile Luminaires

Cl. I, Div. 1, Groups B (GB Suffix), C, D
 Cl. I, Zone 1, Groups IIB + H₂ (GB suffix), IIB, IIA
 Cl. II, Div. 1, Groups E, F, G; Class III, Simultaneous Presence

Marine & Wet Locations
 3, 3R, 4, 4X; IP66
 Emergency Lighting

9L

Applications:

Eaton's Crouse-Hinds Low Profile Hazard•Gard® Luminaires are used in:

- Areas that require lamps to reach full illumination immediately
- Where emergency lighting is required to permit workers in industrial areas to safely encounter their surroundings during power failures
- Where emergency lighting is required such as: catwalks, walkways, tunnels, doorways, stairs, stairwells, ramps, and aisles
- Areas where flammable or explosive vapors or gases are present
- Hazardous areas, both indoors and outdoors, where long life and low maintenance costs are desired
- Petroleum refineries, chemical, petrochemical and pharmaceutical plants, oil terminals, gas plants and other heavy process industry facilities
- Waste treatment facilities
- Drilling platforms and other coastal and offshore hazardous areas

Features and Benefits:

- Small, compact size
- Two start Acme threaded construction
- Easier assembly, installation, and maintenance
- Lightweight copper-free aluminum housing with powdered epoxy finish
- All exterior hardware is corrosion-resistant stainless steel
- Four mounting arrangements: pendant, ceiling, wall bracket, and stanchion
- Integral ballast
- High power factor (90%+) ballasts
- Uses same mounting modules as the standard Hazard•Gard®
- Internally fluted glass globes
- Krydon® construction dome and angle reflectors – won't rust, corrode, dent, chip, or peel
- Now available in components – luminaire body, mounting module, guard, reflectors
- Three wire construction
- For energy conservation, luminaires can be switched off without affecting the emergency operation feature

Certifications and

Compliances:

- NEC/CEC:
 - Class I, Division 1, Groups B (with GB suffix), C, D
 - Class I, Zone 1, Groups IIB + H₂ (GB Suffix), IIB, IIA
 - Class II, Class III & Simultaneous Presence (Class I and Class II) Emergency Lighting
- UL Standards:
 - 844 Hazardous (Classified) Locations
 - 1598 Luminaires
 - 1598A Marine Locations
 - 924 Emergency Lighting
- CSA Standards:
 - C22.2 No. 137

Crouse-Hinds
 by **E•T•N**



Standard Materials:

- Mounting modules, cover, ballast housing, globe holder – copper-free aluminum
- Globe – heat- and impact-resistant glass
- Exterior hardware – stainless steel
- Reflectors (dome & angle) – Krydon® fiberglass-reinforced polyester

Standard Finishes:

- Copper-free aluminum – Corro-free™ powdered epoxy
- Krydon – white
- Stainless steel guard

Energy Savings

- Less wattage used with compact fluorescent lamps compared to equivalent incandescent lamps providing the same light output

Options:

Description	Suffix
Group B suitability	GB
Fused (not for use in Canada) (not for marine use)	S658*
Factory assembled with lamps	FA
Emergency operation only – Consult Eaton's Crouse-Hinds	

*When ordering fuses for luminaires, option S658, you must specify the operating voltage. S658 cannot be ordered with /MT in the catalog number.

Accessories:

Description	Cat. #
Dome reflector	RD739
Angle reflector	RA739

About the Battery:

- Bodine fluorescent battery pack ballasts are UL component recognized
- Sealed, maintenance-free, high temperature nickel cadmium
- Solid state chargers are sealed inside the ballast case; 90 minute illumination time; 10-year life expectancy
- 2-year warranty
- During emergency use, 1 lamp has continuous operation
- A red indicator light indicates the battery is charging
- Wiring instructions for a "Push-to-Test" button is supplied with the fixture

9L

9L

EVLPFB Emergency Compact Fluorescent

Continuous Operation
Low Profile Luminaires

Cl. I, Div. 1, Groups B (GB Suffix), C, D
Cl. I, Zone 1, Groups IIB + H₂
(GB suffix), IIB, IIA
Cl. II, Div. 1, Groups E, F, G; Class III,
Simultaneous Presence

Marine & Wet
Locations
3, 3R, 4, 4X; IP66
Emergency Lighting

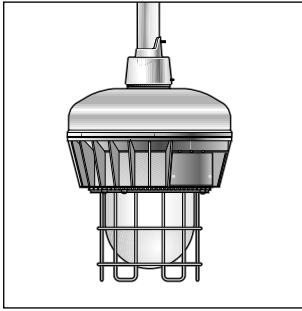

Pendant Mount

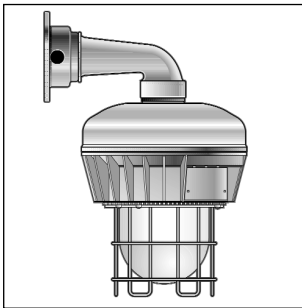

Wall Bracket Mount†

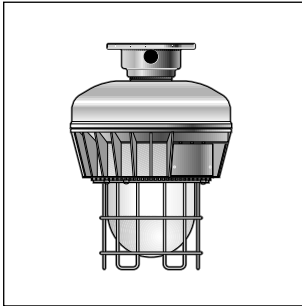

Ceiling Mount†

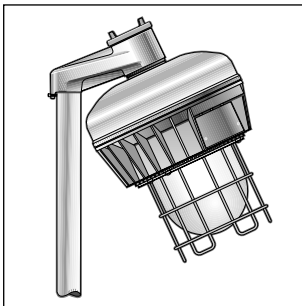

Stanchion Mount

Ordering Information:

		Pendant	Wall Bracket†	Ceiling†	Stanchion	Luminaire Body Less Mounting Module & Guard
Watt	Hub Size (In.)	With Guard Cat. #	With Guard Cat. #	With Guard Cat. #	With Guard Cat. #	Cat. #
Fluorescent with Emergency Ballast – High Power Factor Ballast (Min. P.F. 90%)						
52W	3/4	EVLPFBA02521	EVLFPBBX02521	EVLPFBCX02521		EVLPFB0520
	1	EVLPFBA03521	EVLFPBBX03521	EVLPFBCX03521		
	1 1/4				EVLFPBJ04521	
64W	3/4	EVLPFBA02641	EVLFPBBX02641	EVLPFBCX02641		EVLPFB0640
	1	EVLPFBA03641	EVLFPBBX03641	EVLPFBCX03641		
	1 1/4				EVLFPBJ04641	

Complete Catalog Numbers as follows:

		Standard Voltage Ballasts	
		NEC/UL	CEC/CSA (cUL)
1. Voltage Suffix		120-277V 50-60 Hz /UNV	120V/60 Hz /120CAN 347V 60 Hz /347
2. Example: EVLPFB02521/UNV		Other Voltages – Consult Eaton's Crouse-Hinds	

Note: For technical information on family trees, temperature performance data, dimensions, weights, and photometrics, refer to DMVF Series in Section 5L.

EVFPFB Fluorescent Emergency Lighting

- Three wire construction, for switching purposes, is standard on fluorescent emergency lighting.
- For energy conservation, luminaires can be switched off without affecting the emergency operation feature.

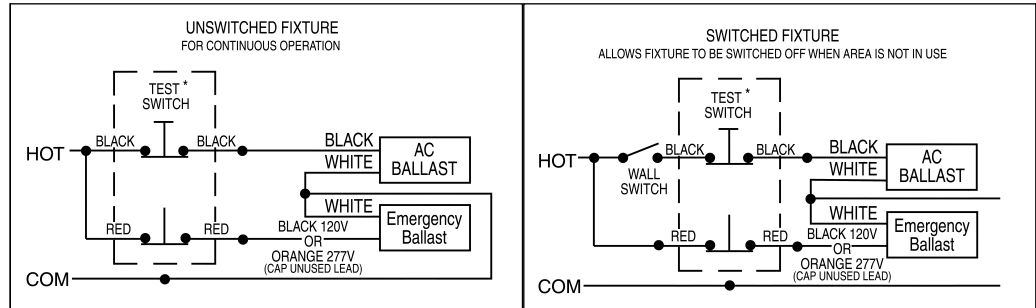

*Test switch is remote mounted.
Use Eaton's Crouse-Hinds EDSC218 (not furnished).

9L

†Ceiling and bracket mounts have 4 hubs: 3 are plugged.

Ex-Lite LED Exit Signs

Cl. I, Div. 2, Groups A, B, C, D
 Cl. I, Zone 1, AEx em ib IIC (NEC)
 Cl. I, Zone 1, Ex em ib IIC (CEC)
 Cl. II, Div. 2, Groups F, G (NEC)
 Cl. II, Div. 2, Groups E, F, G (CEC)

UL Listed
 IP66

9L

The Ex-Lite Series of LED exit signs are designed for hazardous locations and are ideally suited for marking escape routes and exits in potentially explosive atmospheres.

The Ex-Lite Z is available as an AC only version, while the Ex-Lite ZE is available with self-contained battery. As an emergency lighting luminaire with self-contained battery system, the Ex-Lite ZE features a nickel cadmium battery with automatic test and monitoring feature.

Applications:

- In harsh and hazardous environments where illuminated exit signs are required

Features and Benefits:

LED Technology:

- Long life (>50K hours) for years of maintenance-free operation
- Energy-efficient for lower cost of operation
- Low temperature operation with no loss of illumination
- Rugged and durable light source for the harshest of environments

Exit Sign System:

- Can be used in a hazardous location
- Conduit or cable entry
- Can be installed in moist, humid, rain, and wet environments
- Universal input voltage 110VAC-277VAC and 110VDC-250VDC reduces inventory
- Ex-Lite ZE with self-monitoring, self-diagnostic, and test capability
- Premium heavy-duty nickel cadmium battery
- 24-hour charge and recharge time increases safety by recovering quickly from outage
- "EXIT" legend with alternative wings - left, right, or left and right; simple field modification
- Emergency lighting cycle three hours
- The housing of the luminaire is constructed with a corrosion resistant, robust, lightweight aluminum alloy material and illumination of the sign is provided with red, high-efficient LEDs

Certifications and Compliances:

- Class I, Division 2, Groups A, B, C, D
- Class I, Zone 1, AEx em ib IIC (NEC)
- Class I, Zone 1, Ex em ib IIC (CEC)
- Class II, Division 2, Groups F, G (NEC)
- Class II, Division 2, Groups E, F, G (CEC)
- IP66
- UL844
- UL924/CSA22.2 No. 141-02
- UL60079/CSA22.2 E60079
- UL1203/CSA22.2 E6124-1-1-02

Crouse-Hinds

by **EATON**



Ordering Information:

Catalog Number	Ex Lite Z	Ex Lite ZE
Material Number	12191001005	12191130005
Description	AC/DC Exit Sign	with Battery
Light Source	LED	LED
Life of LED	50K hours	50K hours
Rated Voltage, VAC	120V-277V	120V-277V
Frequency, Hz	50/60	50/60
Rated Voltage, DC	110V-250V	110V-250V
Power Consumption	6VA	6VA
Battery	N/A	NiCad
Allowable Temperature Range	-4°F to 122°F (-20°C to 50°C)	41°F to 95°F (5°C to 35°C)*
Mounting	Wall	Wall
Cable Entry	Ex-e	Ex-e
Conduit Entry	3/4"	3/4"
Protection	IP66	IP66

*Due to battery chemistry, the charging capacity will be limited at temperatures below 5°C and above 35°C.

Dimensions

In (mm):

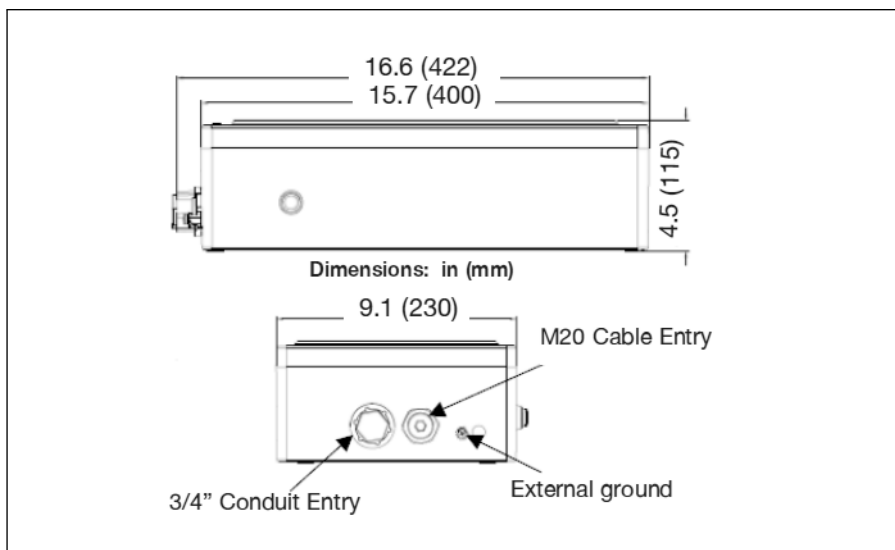

9L

9L CCH UX Series LED Exit Signs

UL Listed
Available with Cl. I, Div. 2,
Groups A, B, C, D rating

NEMA 4X, IP66

Eaton's Crouse-Hinds CCH UX Series LED Exit Sign combines the strength and durability of die cast aluminum with architecturally-pleasing aesthetics. The CCH UX Series is illuminated by LEDs, providing the customer with a long-life, low maintenance, dependable exit sign for use in conditions where reliability is crucial.

Designed for the most severe environments, the CCH UX Series will provide maximum performance against rain, moisture, cold, corrosion, and dust in applications such as manufacturing plants, refineries, petrochemical and chemical plants, waste and sewage treatment facilities, food processing, and other industrial facilities.

Applications:

- In locations deemed hazardous due to the presence of flammable vapors or gases
- In areas where the presence of gases or vapors may become present during an abnormal, unusual, or accidental conditions
- Outdoor and wet applications
- Where required by the National Electrical Code®, Life Safety Code®, or other applicable codes

Features and Benefits:

- Wet location, outdoor rated for use in the most demanding environments
- Optional hazardous location rating available
- Dual voltage 120V/277V reduces wiring errors
- Heavy-duty nickel cadmium battery for long life
- 24-hour charge and recharge recovery time increases safety
- Heavy-duty injection molded polycarbonate lens protects against impact and corrosion
- Brown-out protection protects battery and reduces labor
- Heavy-duty aluminum die cast housing protects against impact and chemical resistance
- LEDs provide long life, even illumination, and energy savings
- Wide operating temperature range (-45°C to 45°C)
- Self-diagnostic testing reduces costs by eliminating scheduled equipment verification tests
- Heavy duty nickel cadmium battery for long life meets 90 minute requirements for battery operated emergency system

Certifications and Compliances:

- NEMA 4X, UL50
- UL924 wet location
- IP65, IP66
- Available with NEC hazardous location rating - UL844 Class I, Division 2, Groups A, B, C, D

Dimensions

In Inches:

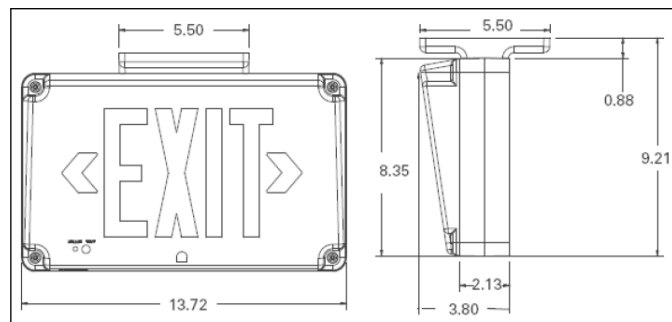

Mounting: wall mount, ceiling mount, end mount
Conduit Entry: top, bottom, or either side of the unit



Benefits of LED Technology:

- Provides safe and reliable exit marking both indoors and outdoors during power failure or interruption of power to normal lighting system
- Long life (>50K hours) for years of maintenance-free operation
- Energy-efficient for lower cost of operation
- Low temperature operation with no loss of illumination
- Rugged and durable light source for the harshest of environments

Temperature Performance Data:

CCH UX Series Exit Sign:

- -45°C (-49°F) to 45°C (113°F)

CCH UX-HAZ Hazardous Location Exit Sign:

- T6 rating at 45°C (113°F)

Electrical Ratings:

- Power Supply
120V/277V dual voltage

- LED Exits - Red
Input Power
120V = 2.7W
277V = 3.2W

- LED Exits - Green
Input Power
120V = 2.3W
277V = 3.0W

- Input Current:
(Max.)
120V = .07A
277V = .04A

- Input Current:
(Max.)
120V = .08A
277V = .03A

Ordering Information:

Catalog Number	Housing Finish	Letter Color
CCH UX70RSDHAZ	Silver Housing	Red LED
CCH UX60RHAZ	Silver Housing	Red LED
CCH UX70GSDHAZ	Silver Housing	Green LED
CCH UX60GHAZ	Silver Housing	Green LED
CCH UX70RSD	Silver Housing	Red LED
CCH UX70RWHSD	White Housing	Red LED
CCH UX70RBKSD	Black Housing	Red LED
CCH UX60R	Silver Housing	Red LED
CCH UX60RWH	White Housing	Red LED
CCH UX60RBK	Black Housing	Red LED
CCH UX70GSD	Silver Housing	Green LED
CCH UX70GWHSD	White Housing	Green LED
CCH UX70GBKSD	Black Housing	Green LED
CCH UX60G	Silver Housing	Green LED
CCH UX60GWH	White Housing	Green LED
CCH UX60GBK	Black Housing	Green LED

Crouse-Hinds
by **E.T.N**

**Tank, Task and Gauge Lighting
Hazardous and Non-hazardous Locations**

Description	Page No.
Application/Selection	see page 1210
Gauge Light	see page 1216
Tank Light	
V160	see page 1211
EVA160	see page 1212
Task Light	
EVTL1B50	see pages 1213–1215
EVTL1L50	see pages 1213–1215

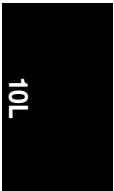

10L Specialty Lighting

Tank, Task and Gauge Hazardous and Non-hazardous Locations Application and Selection

Applications:

Specialty lighting luminaires are used:

- For various task lighting requirements in locations that are hazardous (classified) due to the presence of combustible dusts or easily ignitable fibers and flyings
- In areas where conventional lighting is not acceptable due to size and/or location
- In locations where an adequate light source is necessary for tank, instrument, and gauge applications
- In manufacturing plants, refineries, pharmaceutical, chemical, petrochemical, and other industrial process facilities, waste or sewage treatment facilities, grain processing and handling facilities, and other heavy industrial applications

Considerations for Selection:

Environmental:

- What is the hazardous area classification (NEC)/(CEC) of the location in which the luminaire will be installed?

Lighting levels required:

- What wattage luminaire(s) will provide the desired light level?

Physical Arrangement:

- Type of fixture mounting needed

Product Selection:

- EV Tank Lights are suitable for use in Class I, Groups C, D hazardous (classified) locations; tank lights are used to light the inside of tanks, vats, process vessels, etc.
- EVTL Explosionproof Task Lights are suitable for use in Class I, Group B, C, D and Class II, Groups E, F, G hazardous (classified) locations; EVTL Lights are ideal for applications in which water spray and corrosive atmospheres are considerations
- ELG Gauge Lights are suitable for use in Class I, Groups C, D hazardous (classified) location; the light is used to illuminate liquid level gauges and to direct the light over the length of the column

Applications:

The incandescent V Observation Luminaire is used:

- In tanks or kettles where food is processed
- To light the inside of tanks for observation of the contents through a window

Features:

- Watertight
- Supported by a mounting ring which contains holes for riveting when placed around a hole in the tank; it can also be welded or brazed to the tank
- Heavy heat and impact-resistant glass globe eliminates breakage and resultant contamination of food from glass particles
- Relamping is easily accomplished by removal of the two thumb-screws which fasten the body to the mounting ring
- The flexible cord or cable should be connected by an EC flexible coupling or CG Series connector

Certifications and Complies:

- UL Standard: 1571
- CSA Standard: C22.2

Standard Materials:

- Mounting ring – silicon bronze
- Fixture body – *Feraloy*® iron alloy
- Globe – heat-resisting glass

Standard Finishes:

- *Feraloy* – electrogalvanized and aluminum acrylic paint
- Bronze – natural

Size Ranges:

- Up to 100 watt, A-21 lamp



Furnished with EV10 Globe, and C166 Medium Base Lamp Receptacle

Hub Lamp Size	Size	Cat. #
1 1/2"	50, 60, 75 or 100W, A-21	V160

Dimensions In Inches:

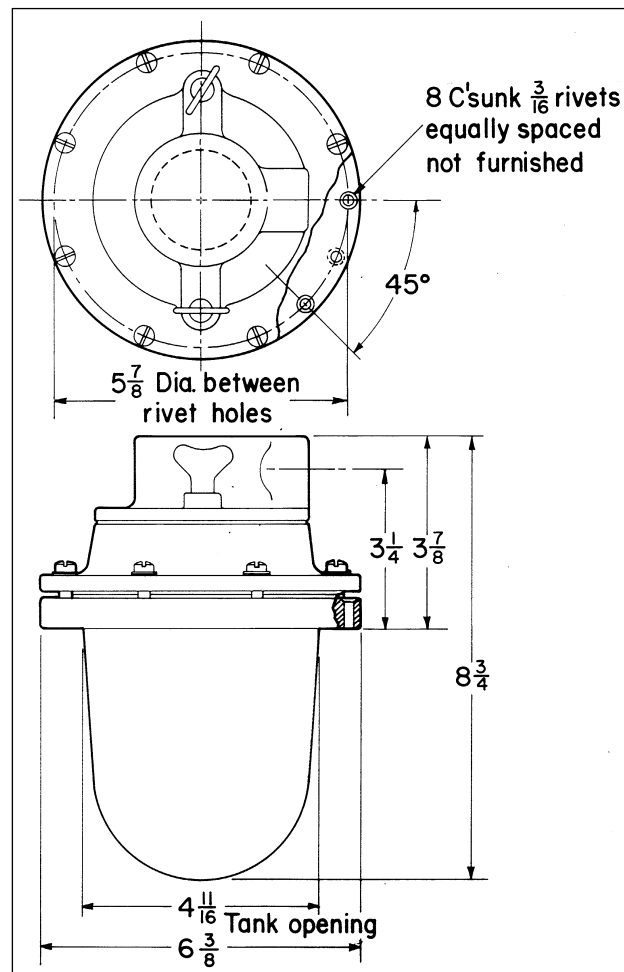

10L EV Tank Luminaires

Cl. I, Div. 1 & 2, Groups C, D
 Cl. I, Zone I & 2, IIB
 Cl. II, Div. 1, Groups E, F, G – EVO only

Applications:

- EV Tank Light Luminaires are used:
- To light inside of tanks, vats, process vessels, etc.
 - In chemical plants, petrochemical plants and petroleum process industries
 - Suspended over tank porthole by EC flexible hanger (EVO style)
 - Mounted directly in tank wall (EVA)

Features:

- High light output
- Compact design

EVA160:

- Furnished with tank ring having eight $\frac{3}{16}$ " holes for riveting to tank
- Can be brazed if desired
- Luminaire ring is attached to the tank ring by eight $\frac{1}{4}$ -20 Allen Head cap screws
- Luminaire attached to luminaire ring by four wing screws
- EC flexible luminaire support should be used so relamping can be accomplished without disturbing the globe

Certifications and Complies:

- NEC:
 - Class I, Division 1 and 2, Groups C, D – EVO and EVA
 - Class II, Division 1, Groups E, F, G – EVO only
- UL Standard: 844

Standard Materials:

- Bodies – EVO: copper-free aluminum; EVA: receptacle housing and intermediate ring – *Feraloy*[®] iron alloy; Tank ring – silicon bronze
- Globes – EVO – glass, heat strengthened plate glass; EVA: glass, heat- and impact-resistant

Standard Finishes:

- Copper-free aluminum – epoxy powder coat
- *Feraloy* iron alloy – cadmium electrogalvanized and aluminum acrylic paint
- Silicon bronze – natural

Size Ranges:

- $\frac{1}{2}$ " and $\frac{3}{4}$ " hubs

Capacity Ranges:

- EVO – 75 watt, reflector spot max.
- EVA – 100 watt, A-21 max.

Temperature Performance Data: Based on 40°C Ambient

Cat. #	Class I, Groups C, D	Class II, Groups E, F, G	Supply Wire (°C)
EVO2376	T3C	T3C	75
EVA160	T3C*	—	75

*All mounting positions.

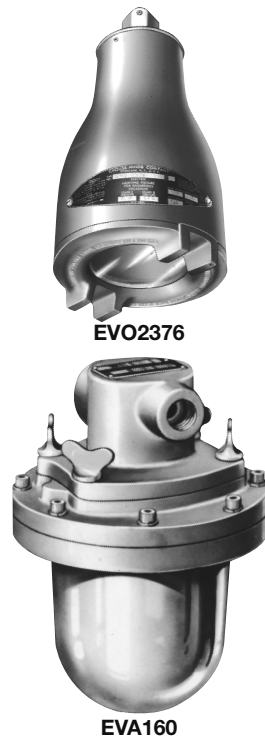

Dimensions In Inches:

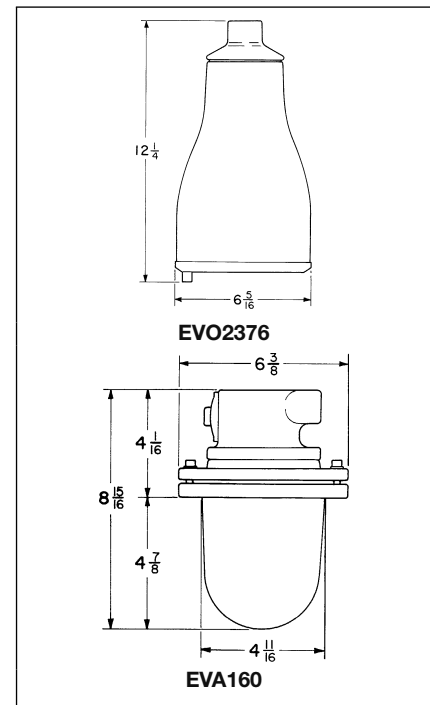

Ordering Information:

Cat. #	Watts	Lamp (not furnished)	Hub Size
EVO2376	75	75R 30/SP reflector spot (medium base)	$\frac{1}{2}$ & $\frac{3}{4}$
EVA160	100, A-21	Medium base	$\frac{1}{2}$

Tank Ring Mounting EVA160

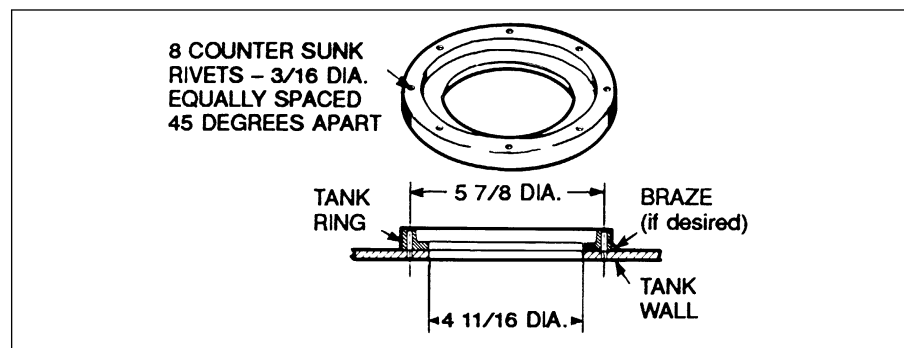

EVTL Explosionproof Task Light

Cl. I, Groups B, C, D
 Cl. I, Zone I, IIB+H₂
 Cl. II, Groups E, F, G
 Class III Simultaneous Presence

Wet Locations
 Marine Locations
 NEMA 3, 3R, 4, 4X

10L

Applications:

EVTL Task Light Luminaires are used:

- For various task lighting requirements in locations that are hazardous (classified) due to the presence of flammable gases or vapors, combustible dusts, or easily ignitable fibers and flyings
- In marine applications where water spray and corrosive atmospheres are considerations
- In areas where conventional lighting is not acceptable due to size and/or location
- In locations where an adequate light source is necessary for tank, instrument, and gauge applications
- In porthole or sightglass applications where a spotlight is required for visibility inside tanks, vats, and process vessels
- In manufacturing plants, refineries, pharmaceutical, chemical, petrochemical, and other industrial process facilities, waste or sewage treatment facilities, grain processing and handling facilities, and other heavy industrial applications

Features and Benefits:

- Class I, II, III, Simultaneous Presence - suitable for most hazardous (classified) areas
- Class I, Group B standard - suitable for areas containing hydrogen
- Wet and marine (NEMA 4X) suitability - perfect for hose down applications
- 55° ambient suitability addresses higher ambients typical of industrial plants
- Cast copper-free aluminum housing with Corro-free™ epoxy powder coat finish for superior corrosion resistance
- Stainless steel mounting brackets and hardware for superior corrosion resistance
- Two mounting styles (bracket and leg) to maximize mounting flexibility
- Bracket (universal) for ceiling, wall, or base mounting
- Leg (site glass) for site glass mounting
- Uses standard 50 watt PAR 20 medium base 120V lamps - improved light output, economical, long life 2000-2500 hour light source
- Uses 50PAR20 130V lamps for added lamp life - increase lamp life to 5000+ hours while maintaining 76% lumen output
- 50PAR20 lamps available in both flood and spot light patterns - vary the illumination characteristics by simply changing lamps
- Easy access interior reduces maintenance and lamp replacement time
- Seal within 5 ft. (not 18") of luminaire provides greater flexibility in seal location

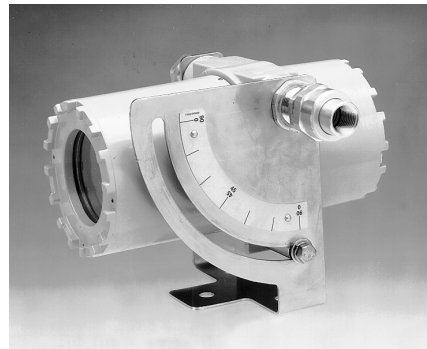

EVTL1B50

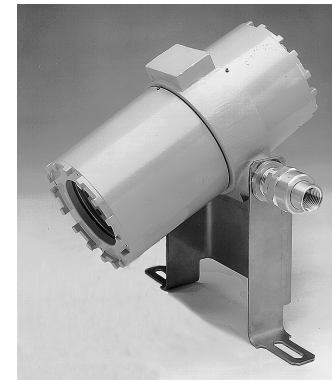

EVTL1L50

Certifications and Compliances:

- NEC/CEC:
 - Class I, Division 1 & 2, Groups B, C, D
 - Class II, Group E, F, G
 - Class III
 - Class I, Zone 1 & 2, Group IIB + H₂
 - Wet locations
 - Marine locations
 - NEMA 4X
- NEC:
 - Simultaneous Presence
- UL Standards:
 - 844—Hazardous (Divisions Classified) Locations
 - 1571—Ordinary and Wet Locations, Marine Outside Type
- CSA Standards:
 - C22.2 No. 137

Standard Materials:

- Housing — copper-free aluminum
- 3/4" NPT hub and plug — aluminum
- Mounting bracket(s) and external hardware — stainless steel
- Gasket — silicone rubber
- Lens — heat- and impact-resistant clear glass

Standard Finishes:

- Aluminum housing (exterior) — Corro-free™ epoxy powder coat
- Stainless steel — natural

Ratings (Electrical/Size):

Source/Wattage (Medium Base Lamps)

- 50PAR20 type—50W 120V halogen parabolic reflector; lamp life 2000-2500 hrs.
- 130V lamps available to extend lamp life to 5000+ hrs.

Voltage

- 120V 60 Hz

Hub Size

- (1) 1/2" NPT
- For through-feed, use EVTL-TF1

Ordering Information:

Cat. #	Conduit Entry	Mounting Style	Wattage
EVTL1B50	1/2"	Bracket (Universal)	50
EVTL1L50	1/2"	Leg (Site Glass)	50

Temperature Performance Data:

Cat. #	Maximum Ambient °C	Class I, Div. 1, Groups B, C, D Class II, Div. 1, Groups E, F, G Class III Simultaneous Presence Class I, Zone 1, IIB + H		Supply Wire °C
EVTL1B50	40	T3B		85
EVTL1L50	40	T3B		85

Install luminaire within aiming ranges shown on nameplate (see Dimensions).

10L

Aiming Range:

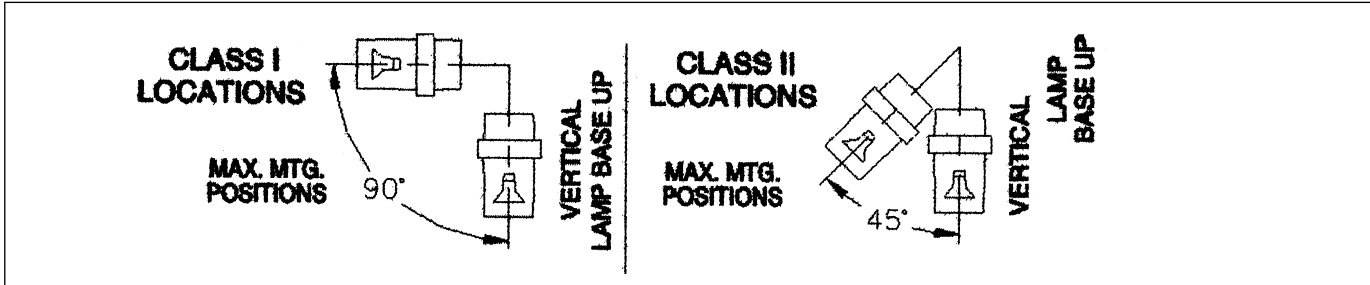

Dimensions:

Bracket Mount

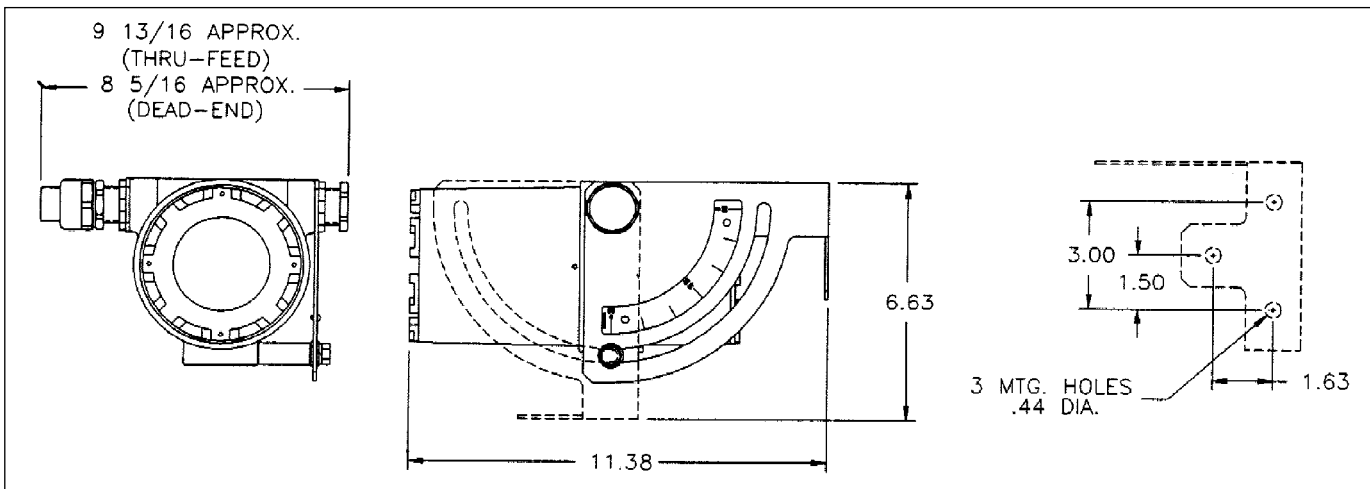

Dimensions:

Leg Mount

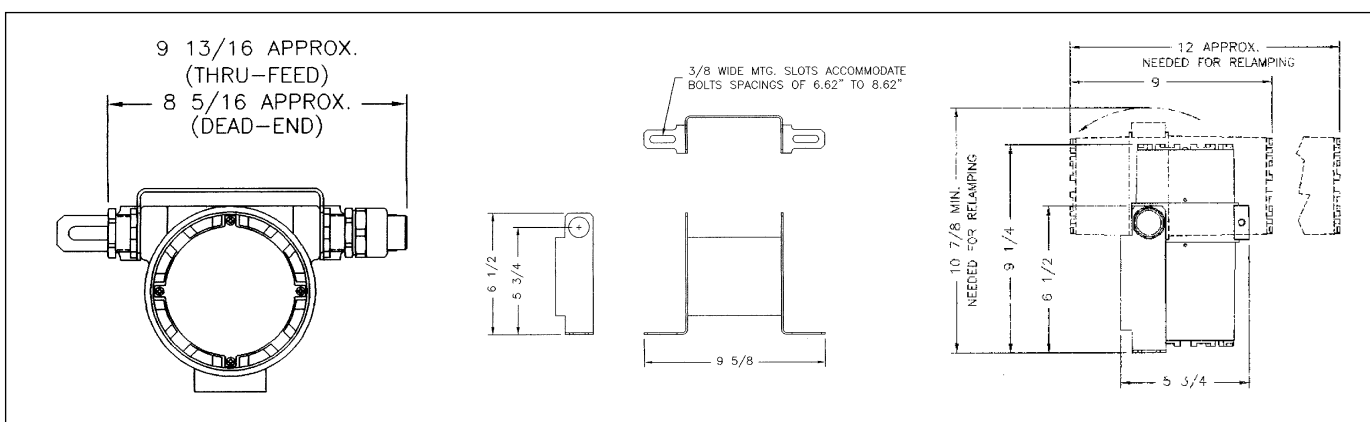

Net Luminaire Weights: (lbs.)

Luminaire Cat. #	Weight (lbs.)
EVTL1B50	7
EVTL1L50	7
EVTL-TF1	1/2

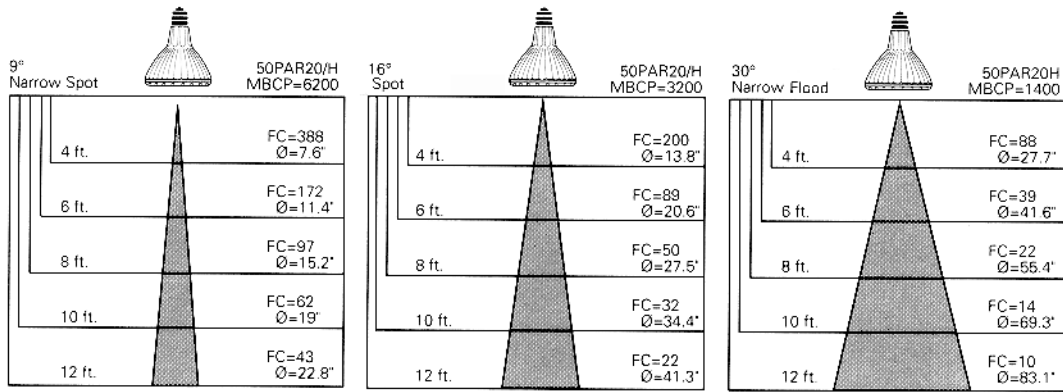

MBCP = Maximum Beam Candlepower Ø = Diameter of beam spread in inches FC = Footcandles measured at 0°

Lamp Light Distribution – (Philips lamp data shown. Similar for other manufacturers.)

Data shown is for 120 volt lamps.

For 130 volt lamps adjust data using a .76 multiplier.

10L ELG Gauge Luminaires

Cl. I, Div. 1 & 2, Groups C, D
 Cl. I, Zone 1 & 2, IIB
 Explosionproof

Applications:

ELG Gauge Lights are used:

- In hazardous areas to illuminate liquid level gauges over entire length of gauge
- Clamped to rear of liquid level gauge and conduit is attached to the ELG hubs; light is reflected by Lucite reflector along the entire length of the gauge; liquid level shows on front of gauge; all light is concentrated on liquid column – no spill light

Features:

- Even illumination over entire length of gauge
- Variety of sizes to fit many gauges
- Several lights can be used in tandem to illuminate long gauge

Certifications and Compliances:

- NEC/CEC:
 Class I, Division 1 and 2, Groups C, D

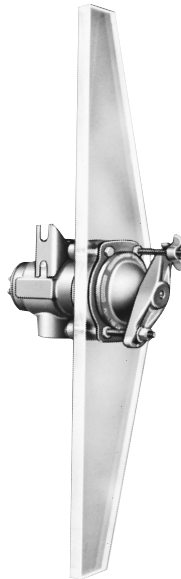

ELG329 with LE49 reflector

Standard Materials:

- Body – copper-free aluminum
- Reflectors – plexiglass

Standard Finishes:

- Body – electrogalvanized and aluminum acrylic paint

Size Ranges:

- 1" conduit through-feed

Capacity Ranges:

- 120V medium screw base "A19" style incandescent lamp 58W maximum
- 25 watt – medium base – 1000 hour life
- 52 watt – medium base – 2500 hour life
- 58 watt – medium base – 3000 hour life

Ordering Information:

Description	Length (L) (inches)	Cat. #
Gauge Light (less reflector)	—	ELG329
Short	4½	LE34
– Style Reflector	5½	LE35
Long	13	LE46
– Style Reflector	15	LE47
	17	LE48
	19¾	LE49
	22	LE410
	25¼	LE412
	26¾	LE413

Dimensions:

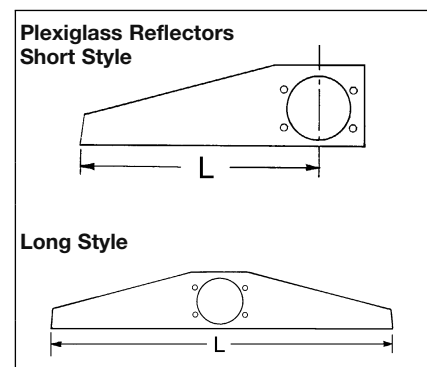

10L

Temperature Performance Data:

Based on 40°C ambient
 58 Watt – T4A Maximum

Options:

Description	Suffix
Group B suitability	GB

Suggested Lamps: Lamps not furnished

Manufacturer	Cat. #			Volts
	25 Watt	52 Watt	58 Watt	
General Electric	25A	60A/52WMP/98		120
Osram/Sylvania	25A	60A/52/SS/XL	58A19/62	120
Philips	25A	60A-52A/99/EW		120