

Industrial Control & Circuit Breakers

Section C

Innovative, intelligent NEC and IEC solutions safely and efficiently control power and protect circuits in explosive, wet, and corrosive environments worldwide.



New Products in the Control Product Line

- EGL Static Grounding Indicator
- EJB Custom Control Panels
- Explosionproof Variable Frequency Drives

Section

- 5C
- 5C
- 6C

Notable changes to the Control section of this catalog

- Section 4C reorganized to capture all traditional control stations
- Section 5C reorganized to capture specialty control stations
- New section 6C for explosionproof variable frequency drives
- Section 8C has been removed. For Intrinsically Safe products, please visit Cooper Crouse-Hinds MTL Instruments at www.mtl-inst.com



CHS Controls AB

Florettgatan 33
SE-254 67 Helsingborg, Sweden
Tel +46 42 38 61 00, Fax +46 42 38 61 29
chs@chscontrols.se
www.chscontrols.se

Table of Contents

Section C of the Cooper Crouse-Hinds Product Catalog lists motor control, circuit breakers, variable frequency drives, and switchracks. Information on application, features, standard materials, standard finishes, size ranges, compliances, options, and accessories are presented for ease of product selection.

Information relating to product families in Section C is grouped as follows:

Section 1C

Combination Motor Starters

(for hazardous and non-hazardous areas)

Combination magnetic line starters and enclosures for across-the-line motor starting, motor disconnect, motor and line protection, and start-stop operations.

For hazardous areas	For non-hazardous areas
EBMC	NMC
EPC	

Section 2C

Motor Starters

(for hazardous and non-hazardous areas)

Line starters and enclosures for manual and magnetic across-the-line starting of motors, motor protection, and remote and manual starting and stopping.

Magnetic starters	Manual starters	
EBMS	EID	GHG
EPC	EFD	NSSC
NMG	EDS	NFSC
	EMN	NMN
	MC	

Section 3C

Circuit Breakers

(for hazardous and non-hazardous areas)

For use in conjunction with variety of heating, lighting, and power circuits to provide disconnect means and short circuit protection.

For hazardous areas	For non-hazardous areas
EBMB	NCB
EFD	
EPC	
EIB	
FLB	

Section 4C

Traditional Control Stations

(for hazardous and non-hazardous areas)

For means of remote and local motor control, visual indicators and circuit control and selection. Offers a selection of push buttons, pilot lights, selector switches.

For hazardous areas	For non-hazardous areas	
FlexStation	MC / MCC	
EDS / EDSC	OAC	MC
EDSCM	GHG43	
DSD / DSD-SR	N2SU / N2SCU	
EDS	N2FA / N2FAC	
EDSCM	N2S / N2SC	
EFS		
MC / MCC		
OAC		

Section 5C

Specialty Control Stations

(for hazardous and non-hazardous areas)

For means of remote and local motor control, visual indicators and circuit control and selection. Offers a selection of push buttons, pilot lights, selector switches.

EJB Custom Control Panels	AFA / AFAX
EMP / EMPS	D2X
EGL	EGF
AFU / AFUX	

Section 6C

Explosionproof Variable Frequency Drives

(for hazardous areas)

Highly flexible AC drives designed specifically for hazardous area locations. These drives can be mounted next to the motor in the classified area, providing significant installation cost savings - along with the traditional VFD benefits of energy savings, speed and torque control, and system diagnostics.

ACE

Section 7C

Rack Assemblies

(for hazardous and non-hazardous areas)

For motor control centers in outdoor and/or hazardous areas.

For hazardous areas	For non-hazardous areas
ERK	WRK
DRK	



CHS Controls AB
 Florettgatan 33
 SE-254 67 Helsingborg, Sweden
 Tel +46 42 38 61 00, Fax +46 42 38 61 29
 chs@chscontrols.se
 www.chscontrols.se

Description	Page No.
Application/Selection	see page 430
Combination Line Starters and Enclosures	
Single speed, non-reversing, with circuit breakers & disconnect switches	
EBMC Series	see page 431
EPC Series	see page 440
EBMC Series with Advantage* Starter	see page 438
NMC Nonmetallic Series	see page 444
Single speed, non-reversing, with motor circuit protectors	
EBMC Series	see page 437
EPC Series	see page 443

1C



CHS Controls AB
 Florettgatan 33
 SE-254 67 Helsingborg, Sweden
 Tel +46 42 38 61 00, Fax +46 42 38 61 29
 chs@chscontrols.se
 www.chscontrols.se

*Advantage is a trademark of Cutler-Hammer Inc.

Application and Quick Selector Chart

Applications:

Combination line starters are housed in enclosures suitable for specific environments, and are used for:

- Across-the-line starting of polyphase AC induction motors
- Providing disconnect means
- Branch circuit protection
- Motor running protection
- Remote starting and stopping

Considerations for Selection:

Considerations for selection of proper enclosure:

- The environment of the enclosure location in accordance with NEC/CEC and NEMA/EEMAC requirements
- The characteristics of the starter and breaker to be enclosed
- See "Quick-Selector" below for guidance

Materials and Finishes:

- Standard material on EBMC and EPC Series is copper-free aluminum with natural finish
- EBMC and EPC optional finish is *Corro-free*™ epoxy for use in exceptionally corrosive atmospheres
- Standard material on NMC Series is Krydon® high impact fiberglass-reinforced polyester, providing excellent corrosion resistance and stability to heat

Options and Accessories:

Some of the options and accessories available for particular applications are:

- Push buttons
- Selector switches
- Control transformers
- Extra overload relays
- Extra interlock contacts
- Neutral connectors (both insulated and grounded)
- Breathers and drains

See individual listings for specific options. Many are available in kit form for field addition to existing units.

Quick Selector Chart

Enclosures for Combination Motor Starters						
Enclosures	NEC/CEC – Hazardous Area Certifications and Compliance	NEMA/EEMAC Enclosure Type	NEMA/EEMAC Starters	Manufacturers Equipment Enclosed		
				Single Speed Non-Reversing	Starter	Breaker/Switch
EBMC	Cl. I, Div. 1 & 2, Groups B, C, D Cl. II, Div. 1, Groups E, F, G Cl. II, Div. 2, Groups F, G Cl. III	3, 4*, 7BCD, 9EFG, 12	0 – 5	Allen-Bradley G.E. Square D Cutler-Hammer	G.E. Square D Cutler-Hammer	Bolted/Ground Joint/Gasketed
EPC	Cl. I, Div. 1 & 2, Groups C, D Cl. II, Div. 1, Groups E, F, G Cl. II, Div. 2, Groups F, G Cl. III	3, 4, 7CD, 9EFG, 12	0 – 3	Allen-Bradley G.E. Square D Cutler-Hammer	G.E. Square D Cutler-Hammer	Threaded
NMC	–	3, 4X, 12	0 – 4	Allen-Bradley G.E. Square D Cutler-Hammer	G.E. Square D Cutler-Hammer	Gasketed

*Without EMP control devices



CHS Controls AB
 Florettgatan 33
 SE-254 67 Helsingborg, Sweden
 Tel +46 42 38 61 00, Fax +46 42 38 61 29
chs@chscontrols.se
www.chscontrols.se

Applications:

Spectrum™ EBM hinged cover motor control enclosures are used:

- For general motor control and circuit protection – indoors and outdoors – in damp, wet, dirty, dusty hazardous locations without the need for a protective shelter
- In areas where frequent washdowns are necessary or where heavy rain or water spray is prevalent
- For across-the-line starting, stopping, speed changing and reversing of polyphase AC induction motors
- To provide line disconnect means and short circuit protection
- To provide motor overload and undervoltage protection
- For service entrance, feeder or branch circuit protection for lighting, heating, appliance and motor circuits
- On switchracks or other assemblies where it's desired that motor control be centrally located

Features:

- Rugged, corrosion resistant, cast copper-free aluminum construction (less than 0.4 of 1%)
- Component operating handles located through the right side wall of the body permits visual confirmation of correct component assembly and operation
- Total compliance to the wiring end room requirements of the National Electrical Code*/Canadian Electrical Code
- Semi-clamshell enclosure design, with an external flanged ground joint between body and cover makes interior components more accessible
- Minimum enclosure-to-enclosure spacing with little interference between the opened cover and an adjacent enclosure
- Stainless steel hinges allow the cover to swing well out of the way
- Stainless steel, quick release, captive, hex head cover bolts. Stainless steel springs provide clear indication cover bolts are fully retracted from body
- Versatile, internal operating mechanisms allow for field adjustment to accommodate popular manufacturers' starters and breakers
- Simple, straightforward installation of breaker and starter on pre-drilled mounting plate within enclosure. Mounting plate also field removable.
- Circuit breaker motor circuit protector external operating handle can be padlocked in either "ON" or "OFF" positions
- Neoprene cover gasket permanently attached to the cover seals out moisture
- Bodies have top and bottom drilled and tapped entrances for power conduits plus one at the bottom for control conduit. Removable reducers are supplied, as standard, to accommodate smaller size conduits. All conduit entrances are plugged.
- Tap-on mounting feet
- Optional EMPS control devices may be added to enclosure cover
- Steel bracket for lifting larger enclosures during installation supplied as standard

*National Electrical Code is a Registered Trademark of the National Fire Protection Association.

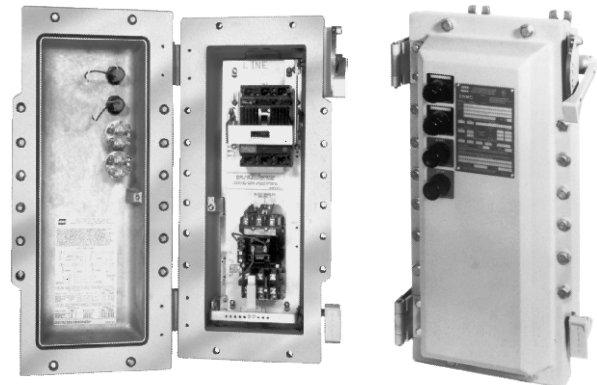

Interior components are readily accessible with ample end room for wiring

Side operators leave cover free for control options

Certifications and Compliances:

- NEC/CEC:
 - Class I, Division 1 & 2; Groups B, C, D
 - Class II, Division 1; Groups E, F, G
 - Class II, Division 2; Groups F, G
 - Class III
- UL Standards UL1203 – Hazardous (classified) locations
- UL Subject 2062 - High AIC rating (Interrupting Capacity) For Groups C & D only

Volt	RMS Symm-Amperes
240	65,000
480	50,000
600	25,000

- CSA Standard: C22.2 No. 30
- NEMA/EEMAC: 3, 3R, 4†, 7BCD, 9EFG, 12

†Enclosure not suitable for NEMA 4 with cover mounted operators.

Standard Materials:

- Body and cover – copper-free aluminum
- Operating handle – copper-free aluminum
- Operating shafts and bushings – stainless steel
- Cover bolts, hinges, washer and retractile springs – stainless steel
- Interior parts – sheet steel, electrogalvanized

Electrical Rating Range:

- Motor starters – NEMA/EEMAC sizes 0-5
- Circuit breakers – 100, 150, 225, 250, 400, 600, 800, 1000† ampere frame sizes
- Motor circuit protectors – 150, 250, 400 ampere frame sizes

† 1000 Ampere Frame (max. 800 ampere trip)



CHS Controls AB
 Florettgatan 33
 SE-254 67 Helsingborg, Sweden
 Tel +46 42 38 61 00, Fax +46 42 38 61 29
 chs@chscontrols.se
 www.chscontrols.se

Cl. I, Div. 1 & 2, Groups B, C, D
 Cl. II, Div. 1, Groups E, F, G
 Cl. II, Div. 2, Groups F, G
 Cl. III
 NEMA 3, 3R, 4 \ddagger , 7BCD, 9EFG, 12

Explosionproof
 Dust-Ignitionproof
 Raintight
 Wet Locations
 Watertight

Options:

The following options are available from the factory by adding suffix to catalog number – suffixes are added alphanumerically.

Catalog Number System Example

EBMC1FB-①-DT30FAL36-W643-②

① Options in this position are additions to the enclosure itself and should be listed alphanumerically.

② Options in this position are modifications to the starter and/or circuit breaker and should be listed alphanumerically.

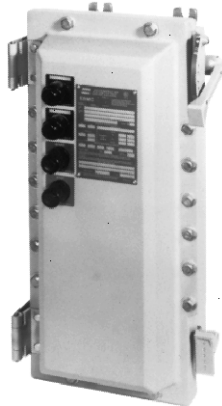

EBMC Series motor control enclosures with combination line starters.

When specifying any one of the following options with Spectrum™ EBM Motor Controls (J1, J3, PB23, RR2, RR3) it is necessary to order DSL Legend Plates for identification and marking of the device(s) being used.

Description	Position in Cat. #	Suffix
• Ambient compensated circuit breaker trip setting ②		AC
• Less overload relays (lighting contactor)..... ①		CL
• Less overload relays (motor contactor)..... ①		CM
• Control Circuit Transformer, 100VA for NEMA/EEMAC sizes 0–2, 600/480/240–120, 50 / 60 Hertz, with provision for fusing both primary leads and one secondary lead (fuses not provided) ①		FTPS100
• Control Circuit Transformer, 200VA for NEMA/EEMAC size 3, 600/480/240–120, 50 / 60 Hertz, with provision for fusing both primary leads and one secondary lead (fuses not provided) ①		FTPS200
• Control Circuit Transformer, 300VA for NEMA/EEMAC size 4, 5 600/480/240–120, 50 / 60 Hertz, with provision for fusing both primary leads and one secondary lead (fuses not provided) ①		FTPS300
• Pilot light, 120VAC, red jewel, w/blank indicating plate ①		J1
• Pilot light, 120VAC, green jewel, w/blank indicating plate ①		J3
• LED pilot lights (in place of standard incandescent lamps) ①		LED
• Less heaters in starter overload relay..... ②		0
• Start-Stop pushbuttons (requires 2 spaces)..... ①		PB23\ddagger
• On-Off selector switch ①		RR2\ddagger
• Hand-Off-Auto selector switch ①		RR3\ddagger
• Space heater, 120 Volt, 25 Watts ①		R11
• Space heater, 240 Volt, 25 Watts ①		R22
• Space heater, 480 Volt, 25 Watts ①		R44
• Automatic reset overload relay ①		S1
• Insulated neutral w/2 connectors ①		S146
• Std. drain, Class I, B,C & D; Class II, E, F & G; Class III ①		S756\ddagger
• Std. breather & drain, Class I, B,C & D; Class II, E, F & G; Class III ①		S756V\ddagger
• External epoxy finish ①		S752
• Internal and external epoxy finish ①		S753
• Additional control contacts, N.O. or N.C. – for single speed, non-reversing starters only (number limited by design of starter. Details on specific makes and sizes on request.)		
Auxiliary contacts on starter 1 N.O. & 1 N.C..... ②		S781
Auxiliary contacts on starter 2 N.O. & 2 N.C..... ②		S782
Auxiliary contacts on starter 3 N.O. & 3 N.C..... ②		S783
• Auxiliary switch on Circuit Breaker 1A and 1B contacts ②		S784
• Auxiliary switch on Circuit Breaker 2A and 2B contacts ②		S785
• 12 Point term. block – 30 Amp, 300V..... ①		S786
• General purpose control relay, 4 pole N.O., contacts rated 10A@600V, coil 120VAC, 50 / 60 hertz ①		S787*

*Use of this option with NEMA/EEMAC Size 0, or 1 starters necessitates using the larger "D" size enclosure.
 \ddagger Enclosure not suitable for NEMA 4 with cover mounted operators. Breather and drain entries must be plugged for NEMA 4 rating.

CHS Controls AB

 Florettgatan 33
 SE-254 67 Helsingborg, Sweden
 Tel +46 42 38 61 00, Fax +46 42 38 61 29
 chs@chscontrols.se
 www.chscontrols.se

Options:

- If desired, markings on indicating plates may be added to catalog number. Select from the list of standard markings below.
- Insert Legend Plate(s) Catalog Number (i.e. DSL16) immediately after optional device in the EBM Catalog Number.
- If EMP devices are to be added in the field, DSL Legend Plates must be ordered separately as they are not furnished with the EMP/EMPS devices.

Example:

EBMC1FB-J1-DSL14-J3-DSL09-DT30FAL36-W643

Use the charts below to select the appropriate legend plate(s) for your application. Markings shown in **bold print** are etched; all others are stamped.

Single Function Legend Plates

Marking	Cat. #
Automatic	DSL16
Blank	DSL01
Blank with single field	DSL02
Close	DSL21
Down	DSL23
Emerg. Stop	DSL17
Fast	DSL46
Forward	DSL18
Hand	DSL15
In	DSL24
Jog	DSL10
Lower	DSL27
On	DSL07
Off	DSL08
Open	DSL20
Out	DSL25
Power On	DSL14
Raise	DSL26
Reset	DSL12
Reverse	DSL19
Run	DSL09
Safe	DSL85
Slow	DSL47
Start	DSL05
Stop	DSL06
Test	DSL13
Trip	DSL11
Up	DSL22

Two Function Legend Plates

Marking	Cat. #
Blank with 2 fields	DSL03
For-Rev	DSL30
Hand-Auto	DSL29
In-Out	DSL35
Off-On	DSL48
Open-Close	DSL32
Raise-Lower	DSL36
Run-Jog	DSL28
Safe-Run	DSL86
Start-Stop	DSL37
Slow-Fast	DSL65
Up-Down	DSL33

Three Function Legend Plates

Marking	Cat. #
Auto-Off-Hand	DSL49
Blank with 3 fields	DSL04
Fast-Off-Slow	DSL41
For-Off-Rev	DSL40
Hand-Off-Auto	DSL39
Run-Off-Jog	DSL38
Open-Off-Close	DSL43
Raise-Off-Lower	DSL87
Slow-Off-Fast	DSL88
Up-Off-Down	DSL44
1-Off-2	DSL42

Background color for all legend plates is black with the following exceptions:

Marking	Plate Color
Start	Green
Stop	Red
Emerg. Stop	Red

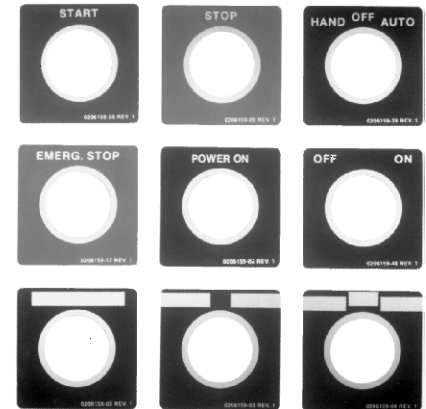

‡Enclosure not suitable for NEMA 4 with cover mounted operators.



CHS Controls AB
 Florettgatan 33
 SE-254 67 Helsingborg, Sweden
 Tel +46 42 38 61 00, Fax +46 42 38 61 29
 chs@chscontrols.se
 www.chscontrols.se

EBMC Combination Line Starters and Enclosures

Dimensions (In inches)†

Cl. I, Div. 1 & 2, Groups B, C, D
 Cl. II, Div. 1, Groups E, F, G
 Cl. II, Div. 2, Groups F, G
 Cl. III
 NEMA 3, 3R, 4‡, 7BCD, 9EFG, 12

Explosionproof
 Dust-Ignitionproof
 Raintight
 Wet Locations
 Watertight

Dimensions In Inches:

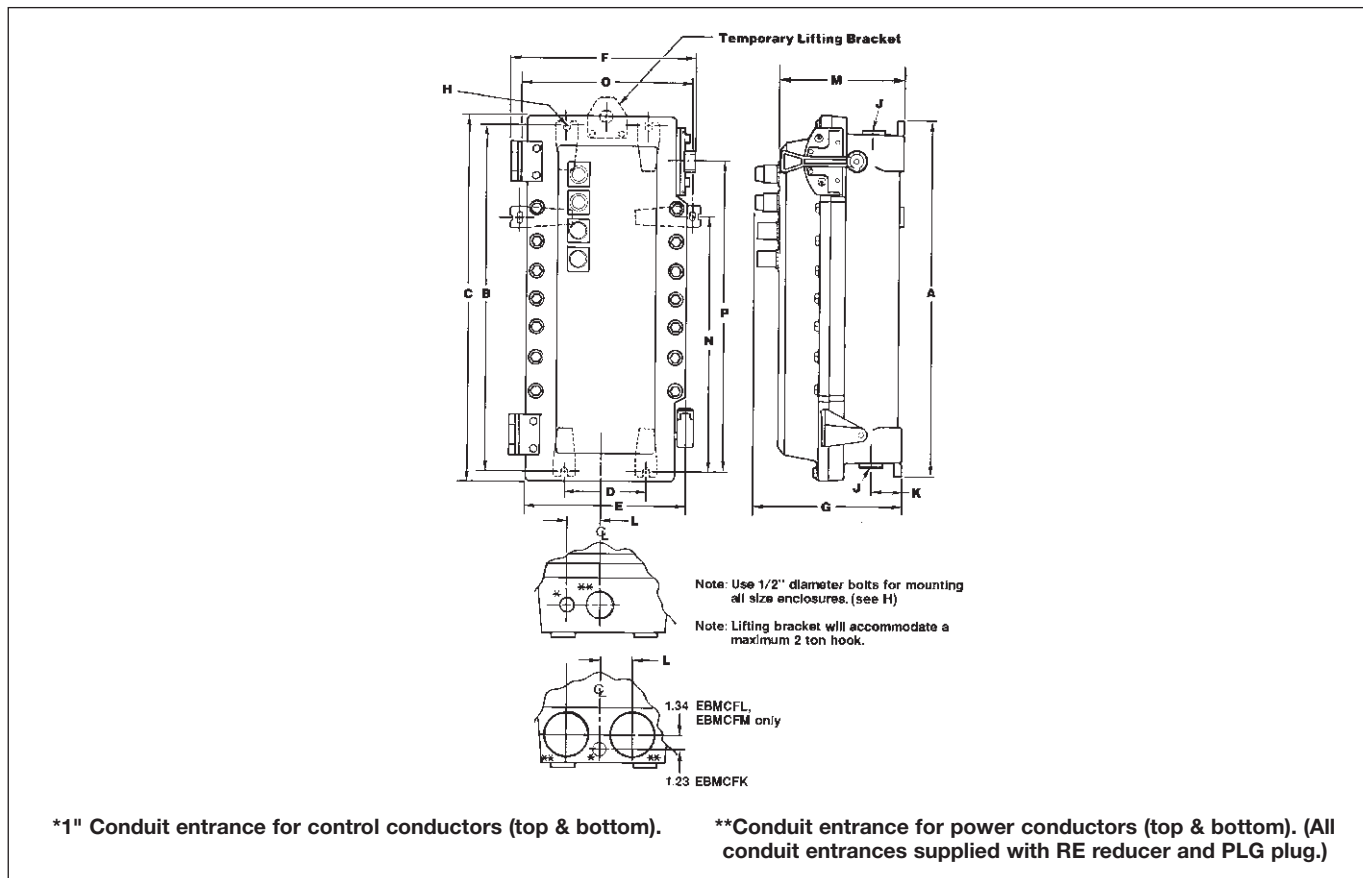

Enclosure Only Cat. #	Enclosure Size Symbol	J** Conduit Entry Trade Size														
		A	B	C	D	E	F	G	D&T [⊗] w/RE	K	L	M	N	O	P	
Size 0, 1 FVNR combination line starter§																
EBMCFB	B	25.75	24.75	26.90	6.00	13.03	14.78	12.13	2"	1.5"	3.25	3.13	10.25	—	—	22.00
Size 2 FVNR combination line starter																
EBMCFD	D	28.25	27.25	29.40	6.00	13.03	14.67	12.13	3"	2.5"	3.25	3.13	10.25	—	—	24.50
Size 3 FVNR combination line starter																
EBMCFG■	G	38.13	36.50	39.28	6.00	13.03	14.78	12.13	3"	2.5"	3.25	3.13	10.25	—	—	34.06
EBMCFH	H	37.50	36.50	38.65	6.00	14.65	16.65	13.54	3"	2.5"	3.25	3.94	11.66	—	—	33.75
Size 4 FVNR combination line starter																
EBMCFK■	K	43.12	41.50	42.65	12.00	17.65	20.46	12.80	(2) 3"	(2) 2.5"	3.25	3.00	10.78	—	—	19.97
EBMCFL	L	53.47	51.50	53.28	12.00	17.90	20.58	15.00	(2) 4"	(2) 3.5"	4.00	3.50	13.03	41.50	18.40	29.88
Size 5 FVNR combination line starter																
EBMCFM	M	64.22	62.50	64.03	12.00	17.90	21.08	15.00	(2) 4"	(2) 3.5"	4.00	3.50	13.03	41.50	18.40	34.46

†Dimensions are approximate, not for construction purposes.
 ‡Enclosure not suitable for NEMA 4 with cover mounted operators.
 §Use EBMCFD enclosure when LVR1 or S787 options are ordered with Size 0 or 1 combination starters.
 ■For Cutler-Hammer W200 Advantage® starters.
 ⊗Drilled & Tapped.



CHS Controls AB
 Florettgatan 33
 SE-254 67 Helsingborg, Sweden
 Tel +46 42 38 61 00, Fax +46 42 38 61 29
 chs@chscontrols.se
 www.chscontrols.se

EBMC Combination Line Starters and Enclosures

Single-Speed Non-Reversing with Circuit Breakers 3-Pole 60 hertz, 600VAC Maximum

Cl. I, Div. 1 & 2, Groups B, C, D
Cl. II, Div. 1, Groups E, F, G
Cl. II, Div. 2, Groups F, G
Cl. III
NEMA 3, 3R, 4†, 7BCD, 9EFG, 12

Explosionproof
Dust-Ignitionproof
Raintight
Wet Locations
Watertight

1C

Ordering Information:

To order an enclosure complete with starter and breaker, insert the manufacturer's symbols in the designated positions of the catalog number. Symbols are shown in the footnotes see pages 435-436.

Select the complete Cat. No. below and specify HP, voltage, frequency, RPM, type and full load ampere rating of motor – or specify ampere rating of heaters.

Enclosures only can be ordered. Select from listings below.

Instantaneous magnetic trip circuit breakers (magnetic circuit interrupters) can be supplied. Consult factory.

For combination starters with motor circuit protectors for single speed, non-reversing motors see page 437.

Motor Starter			Circuit Breaker			Enclosure	
Max. HP Polyphase	Line Volts	NEMA Size	Amp Rating	Frame Volts	Frame Types	Without Breaker & Starter Cat. #	With Breaker & Starter Cat. # §
2	120	0	30	240	FAL, TEB	EBMCFB	EBMC0FB ①30②32 ③613
2	120	0	30	480	FAL, TED, EHD	EBMCFB	EBMC0FB ①30②34 ③613
2	120	0	30	600	FAL, TED, FDB	EBMCFB	EBMC0FB ①30②36 ③613
3	240	0	20	240	FAL, TEB	EBMCFB	EBMC0FB ①20②32 ③623
3	240	0	20	480	FAL, TED, EHD	EBMCFB	EBMC0FB ①20②34 ③623
3	240	0	20	600	FAL, TED, FDB	EBMCFB	EBMC0FB ①20②36 ③623
5	480	0	15	480	FAL, TED, EHD	EBMCFB	EBMC0FB ①15②34 ③643
5	480	0	15	600	FAL, TED, FDB	EBMCFB	EBMC0FB ①15②36 ③643
5	600	0	15	600	FAL, TED, FDB	EBMCFB	EBMC0FB ①15②36 ③663
5	240	1	30	240	FAL, TEB	EBMCFB	EBMC1FB ①30②32 ③623
5	240	1	30	480	FAL, TED, EHD	EBMCFB	EBMC1FB ①30②34 ③623
5	240	1	30	600	FAL, TED, FDB	EBMCFB	EBMC1FB ①30②36 ③623
7½	240	1	50	240	FAL, TEB	EBMCFB	EBMC1FB ①50②32 ③623
7½	240	1	50	480	FAL, TED, EHD	EBMCFB	EBMC1FB ①50②34 ③623
7½	240	1	50	600	FAL, TED, FDB	EBMCFB	EBMC1FB ①50②36 ③623
10	480	1	30	480	FAL, TED, EHD	EBMCFB	EBMC1FB ①30②34 ③643
10	480	1	30	600	FAL, TED, FDB	EBMCFB	EBMC1FB ①30②36 ③643
10	600	1	30	600	FAL, TED, FDB	EBMCFB	EBMC1FB ①30②36 ③663
10	240	2	50	240	FAL, TEB	EBMCFD	EBMC2FD ①50②32 ③623
10	240	2	50	480	FAL, TED, EHD	EBMCFD	EBMC2FD ①50②34 ③623
10	240	2	50	600	FAL, TED, FDB	EBMCFD	EBMC2FD ①50②36 ③623
15	240	2	70	240	FAL, TEB	EBMCFD	EBMC2FD ①70②32 ③623
15	240	2	70	480	FAL, TED, EHD	EBMCFD	EBMC2FD ①70②34 ③623
15	240	2	70	600	FAL, TED, FDB	EBMCFD	EBMC2FD ①70②36 ③623
15	480	2	40	480	FAL, TED, EHD	EBMCFD	EBMC2FD ①40②34 ③643
15	480	2	40	600	FAL, TED, FDB	EBMCFD	EBMC2FD ①40②36 ③643
15	600	2	40	600	FAL, TED, FDB	EBMCFD	EBMC2FD ①40②36 ③663
20	480	2	50	480	FAL, TED, EHD	EBMCFD	EBMC2FD ①50②34 ③643
20	480	2	50	600	FAL, TED, FDB	EBMCFD	EBMC2FD ①50②36 ③643
20	600	2	50	600	FAL, TED, FDB	EBMCFD	EBMC2FD ①50②36 ③663
25	480	2	70	480	FAL, TED, EHD	EBMCFD	EBMC2FD ①70②34 ③643
25	480	2	70	600	FAL, TED, FDB	EBMCFD	EBMC2FD ①70②36 ③643
25	600	2	70	600	FAL, TED, FDB	EBMCFD	EBMC2FD ①70②36 ③663
20	240	3	90	240	FAL, TEB	EBMCFH	EBMC3FH ①90②32 ③623
25	240	3	100	240	FAL, TEB	EBMCFH	EBMC3FH ①100②32 ③623
30	240	3	125	480	TED	EBMCFH	EBMC3FH ①125②34 ③623
30	480	3	70	480	FAL, TED, EHD	EBMCFH	EBMC3FH ①70②34 ③643
30	480	3	70	600	FAL, TED, FDB	EBMCFH	EBMC3FH ①70②36 ③643
30	600	3	70	600	FAL, TED, FDB	EBMCFH	EBMC3FH ①70②36 ③663

①②③ See pages 435-436 for configurable options.

To include a 120V coil, insert a "1" between second to last and last character in catalog number. 120V coil standard with FTSP option.
Ex. EBMCFB-①30②32-③613 becomes EBMCFB-①30②32-③6113

†Enclosure not suitable for NEMA 4 with cover mounted operators.
§Starters are furnished with 3 heaters, when heater ratings are fully specified.



CHS Controls AB

Tel +46 42 38 61 00, Fax +46 42 38 61 29
chs@chscontrols.se www.chscontrols.se

EBMC Combination Line Starters and Enclosures

Single-Speed Non-Reversing with Circuit Breakers and Fusible Disconnect Switches

3-Pole 60 hertz, 600VAC Maximum

Cl. I, Div. 1 & 2, Groups B, C, D Explosionproof
 Cl. II, Div. 1, Groups E, F, G Dust-Ignitionproof
 Cl. II, Div. 2, Groups F, G Raintight
 Cl. III Wet Locations
 NEMA 3, 3R, 4†, 7BCD, 9EFG, 12 Watertight

Motor Starter			Circuit Breaker			Enclosure	
Max. HP Polyphase	Line Volts	NEMA Size	Amp Rating	Frame Volts	Frame Types	Without Breaker & Starter Cat. #	With Breaker & Starter Cat. # §
40	480	3	90	480	FAL, TED, EHD	EBMCFH	EBMC3FH ①90②34 ③643
40	480	3	90	600	FAL, TED, FDB	EBMCFH	EBMC3FH ①90②36 ③643
40	600	3	90	600	FAL, TED, FDB	EBMCFH	EBMC3FH ①90②36 ③663
50	480	3	100	480	FAL, TED, EHD	EBMCFH	EBMC3FH ①100②34 ③643
50	480	3	100	600	FAL, TED, FDB	EBMCFH	EBMC3FH ①100②36 ③643
50	600	3	100	600	FAL, TED, FDB	EBMCFH	EBMC3FH ①100②36 ③663
40	240	4	175	600	TFK/ JD/ KAL, TFJ, JDB	EBMCFH	EBMC4FL ①175②36 ③623
50	240	4	200	600	TFK/ JD/ KAL, TFJ, JDB	EBMCFH	EBMC4FL ①200②36 ③623
60	480	4	125	600	TFK/ JD/ KAL, TFJ, JDB	EBMCFH	EBMC4FL ①125②36 ③643
60	600	4	100	600	TFK/ JD/ KAL, TFJ, JDB	EBMCFH	EBMC4FL ①100②36 ③663
75	480	4	150	600	TFK/ JD/ KAL, TFJ, JDB	EBMCFH	EBMC4FL ①150②36 ③643
75	600	4	125	600	TFK/ JD/ KAL, TFJ, JDB	EBMCFH	EBMC4FL ①125②36 ③663
100	480	4	200	600	TFK/ JD/ KAL, TFJ, JDB	EBMCFH	EBMC4FL ①200②36 ③643
100	600	4	150	600	TFK/ JD/ KAL, TFJ, JDB	EBMCFH	EBMC4FL ①150②36 ③663
125	480	5	300	600	TJK/ KD/ LAL, TJJ, KDB	EBMCFM	EBMC5FM ①300②36 ③643
150	480	5	400	600	TJK/ KD/ LAL, TJJ, KDB	EBMCFM	EBMC5FM ①400②36 ③643

Motor Starter			Fusible Disconnect Switch			
Max. HP Polyphase	Max. Line Volts	NEMA Size	Amp Rating	Max. Volts	Switch Type	With Disconnect Switch & Starter Cat. #
5	600	0	30	600	DS161R	EBMC0FD WFD30J36 W643
10	600	1	30	600	DS161R	EBMC1FD WFD30J36 W643
25	600	2	60	600	DS262R	EBMC2FD WFD60J36 W643
30	600	3	100	600	DS363R	EBMC3FH WFD100J36 W643

①Circuit Breakers:

Manufacturer	Symbol
Cutler-Hammer	WT
General Electric	TT
Square D	W

NEMA

Size	Without Switch & Starter Cat. #
0	EBMCFD FD
1	EBMCFD FD
2	EBMCFD FD
3	EBMCFH FD

②Select Circuit Breaker Frame Type based on Frame Size, Voltage, and Manufacturer desired:

Manufacturer	100 Amp. Frame and 150 Amp. Frame 240V AC			480V AC		600V AC		225 Amp. Frame and 250 Amp. Frame 600VAC		400 Amp. Frame 600VAC	
	AC	AC	AC	AC	AC	AC	AC	AC	AC	AC	
Cutler-Hammer	—	EHD	FDB	JD – Interchangeable Trip Unit	JDB – Non-Interchangeable Trip Unit			KD – Interchangeable Trip Unit	KDB – Non-Interchangeable Trip Unit		
General Electric	TEB	TED	TED	TFK – Interchangeable Trip Unit	TFJ – Non-Interchangeable Trip Unit			TJK – Interchangeable Trip Unit	TJJ – Non-Interchangeable Trip Unit		
Square D	FAL	FAL	FAL	KAL				LAL			

③Motor Starters:

Manufacturer	Symbol
Allen Bradley	AB
Square D	D
General Electric	G
Cutler-Hammer	W



CHS Controls AB
 Florettgatan 33
 SE-254 67 Helsingborg, Sweden
 Tel +46 42 38 61 00, Fax +46 42 38 61 29
 chs@chscontrols.se
 www.chscontrols.se

†Enclosure not suitable for NEMA 4 with cover mounted operators.
 §Starters are furnished with 3 heaters, when heater ratings are fully specified.

EBMC Combination Line Starters

Single-Speed Non-Reversing with Motor Circuit Protectors 3-Pole 60 hertz, 600VAC Maximum

Cl. I, Div. 1 & 2, Groups B, C, D
Cl. II, Div. 1, Groups E, F, G
Cl. II, Div. 2, Groups F, G
Cl. III
NEMA 3, 3R, 4 \ddagger , 7BCD, 9EFG, 12

Explosionproof
Dust-Ignitionproof
Raintight
Wet Locations
Watertight

1C

Ordering Information:

Select the complete Catalog No. below and specify HP, voltage, frequency, RPM, type and full load ampere rating of motors or specify ampere rating of heaters.

Motor Starter

Max. HP Polyphase	Volts	NEMA Size	MCP Amp Rating	Enclosure without Starter & MCP Cat. #	Enclosure with Starter & MCP Cat. # §
3	240	0	15	EBMCFB	EBMC0FB ①15A②36 ③623
3	480	0	7	EBMCFB	EBMC0FB ①7A②36 ③643
3	600	0	7	EBMCFB	EBMC0FB ①7A②36 ③663
5	480	0	15	EBMCFB	EBMC0FB ①15A②36 ③643
5	600	0	15	EBMCFB	EBMC0FB ①15A②36 ③663
7½	240	1	30	EBMCFB	EBMC1FB ①30A②36 ③623
7½	480	1	15	EBMCFB	EBMC1FB ①15A②36 ③643
10	480	1	30	EBMCFB	EBMC1FB ①30A②36 ③643
10	600	1	15	EBMCFB	EBMC1FB ①15A②36 ③663
10	240	2	50	EBMCFD	EBMC2FD ①50A②36 ③623
15	240	2	100	EBMCFD	EBMC2FD ①100A②36 ③623
15	480	2	30	EBMCFD	EBMC2FD ①30A②36 ③643
20	600	2	30	EBMCFD	EBMC2FD ①30A②36 ③663
25	480	2	50	EBMCFD	EBMC2FD ①50A②36 ③643
25	600	2	50	EBMCFD	EBMC2FD ①50A②36 ③663
30	240	3	100	EBMCFH	EBMC3FH ①100A②36 ③623
30	600	3	50	EBMCFH	EBMC3FH ①50A②36 ③663
50	480	3	100	EBMCFH	EBMC3FH ①100A②36 ③643
50	600	3	100	EBMCFH	EBMC3FH ①100A②36 ③663
50	240	4	250*	EBMCFL	EBMC4FL ①250④②36 ③623
100	480	4	250*	EBMCFL	EBMC4FL ①250④②36 ③643
100	600	4	250*	EBMCFL	EBMC4FL ①250④②36 ③663
60	240	5	250*	EBMCFM	EBMC5FM ①250④②36 ③623
100	240	5	400	EBMCFM	EBMC5FM ①400④②36 ③623
125	480	5	250*	EBMCFM	EBMC5FM ①250④②36 ③643
150	600	5	250*	EBMCFM	EBMC5FM ①250④②36 ③663
200	480	5	400	EBMCFM	EBMC5FM ①400④②36 ③643
200	600	5	400	EBMCFM	EBMC5FM ①400④②36 ③663

①Motor Circuit Protectors:

Manufacturer	Symbol
Cutler-Hammer	WP
General Electric	TP
Square D	DP

②Select Motor Circuit Protector Frame Type based on Frame Size and Manufacturer desired:

	150 Amp. Frame	250 Amp. Frame	400 Amp. Frame
Cutler-Hammer	HMCP (F-Frame)	HMCP (J-Frame)	HMCP (K-Frame)
General Electric	TEC	TFC	TJC
Square D	FAL	KAL	LAL

③Motor Starters:

Manufacturer	Symbol
Allen Bradley	AB
Square D	D
General Electric	G
Cutler-Hammer	W

‡ Enclosure not suitable for NEMA 4 with cover mounted operators.

*General Electric motor circuit protectors are 225 Amp. Rated.

§Starters are furnished with three heaters when heater ratings are fully specified.

④After the MCP amp rating the following character symbol must be entered to designate the trip range. Consult factory for other trip ranges available.

MCP Amp Rating	Symbol	Trip Range
Cutler-Hammer (WP)		
7	A	21 to 70
15	A	45 to 150
30	A	90 to 300
50	B	150 to 500
100	B	300 to 1000
250	J	1250 to 2500
400	G	1250 to 2500
General Electric (TP)		
7	A	18 to 90
15	A	42 to 198
30	A	90 to 390
50	A	180 to 660
100	A	300 to 1308
225	B	1000 to 2250
400	C	1000 to 3300
Square D (DP)		
7	A	18 to 70
15	A	50 to 180
30	A	100 to 350
50	A	150 to 580
100	A	300 to 1100
250	H	1250 to 2500
400	E	1250 to 2500



CHS Controls AB

Tel +46 42 38 61 00, Fax +46 42 38 61 29
chs@chscontrols.se www.chscontrols.se

Supplied with Cutler-Hammer Advantage™ Starters

Cl. I, Div. 1 & 2, Groups B, C, D Explosionproof
 Cl. II, Div. 1, Groups E, F, G Dust-Ignitionproof
 Cl. II, Div. 2, Groups F, G Raintight
 Cl. III Wet Locations
 Type 3, 3R, 4†, 7BCD, 9EFG, 12 Watertight

Applications:

Spectrum EBM-E series of hinged cover motor control enclosures are used:

- For general motor control and circuit protection – indoors and outdoors – in damp, wet, dirty, dusty hazardous locations without the need for protective shelter.
- In areas where frequent washdowns are necessary or where heavy rain or water spray is prevalent.
- For across-the-line starting and stopping of polyphase AC induction motors.
- To provide line disconnect means and short circuit protection (EBMC).
- To provide motor overload and undervoltage protection.
- For feeder or branch circuit protection for lighting, heating, appliance, and motor circuits (EBMC).
- On switchracks or other assemblies where it's desired that motor control be centrally located.

Features:

- Total compliance to the wiring end room requirements of the National Electrical Code®.
- Solid state electronic Cutler-Hammer Advantage™ starter.
- Smaller enclosures required than for conventional starter applications.
- Elimination of heater elements, contact chatter, and welding due to low voltage supply.
- Precise overcurrent protection and constant coil power.
- Same performance and labor-saving benefits from the versatile Spectrum EBM Enclosure product line.
- Universal mounting plates and hardware for all major manufacturers' components.
- Mercury switch electronic overload reset.
- Optional EMPS control devices may be added to enclosure cover.

Certifications and Compliances:

- NEC/CEC:
 Class I, Division 1 & 2, Groups B, C, D
 Class II, Division 1, Groups E, F, G
 Class II, Division 2, Groups F, G
 Class III
- UL Standards UL1203 – Hazardous (classified) locations
- CSA Standard: C22.2 No. 30
- UL Subject 2062 - High AIC rating (Interrupting Capacity)

Volt	RMS Symm-Amperes
240	65,000
480	50,000
600	25,000

- NEMA/EEMAC: 3, 3R, 4†, 7BCD, 9EFG, 12

Standard Materials:

- Body and cover – copper-free aluminum
- Operating handle – copper-free aluminum
- Operating shafts and bushings – stainless steel
- Interior parts – sheet steel, electrogalvanized
- Cover bolts, washers, and retractile springs – stainless steel

Electrical Rating Ranges:

- Motor starters – NEMA sizes 1-5

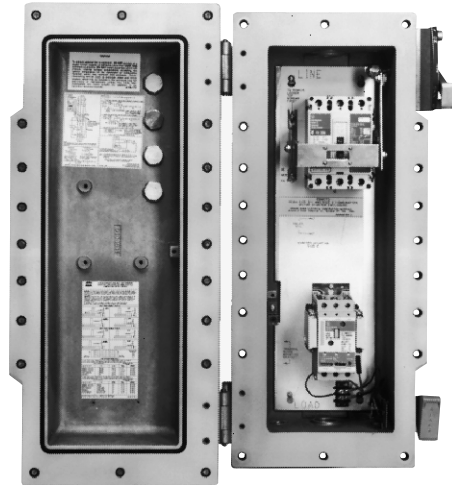

Spectrum EBM-E Series Combination Line Starter with Advantage Starter.

Options:

- See page 439 for options for the EBM enclosures supplied with Cutler-Hammer Advantage starters. The following suffixes cannot be ordered with this style equipment: C, LVR1, O, S.

Dimensions In Inches:

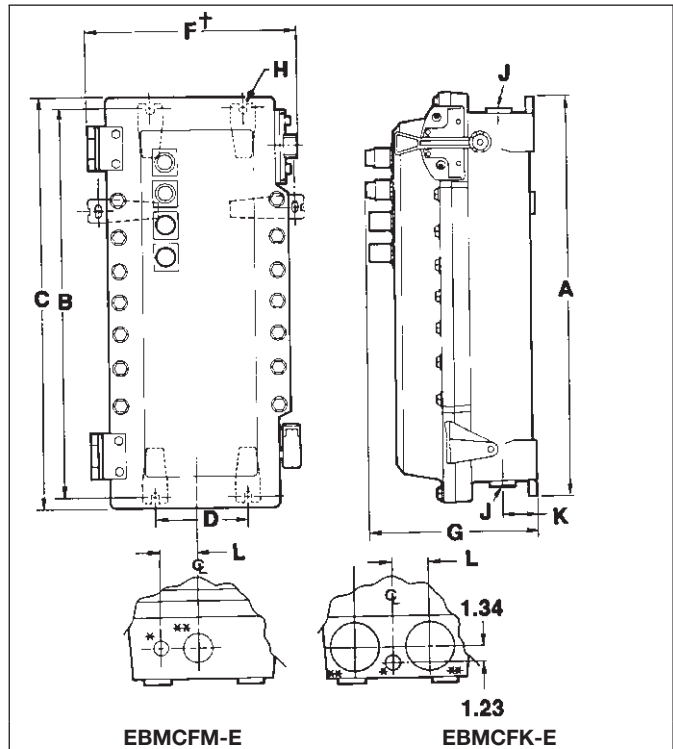

See page 439 for dimensions of different enclosure sizes.
 *Advantage is a trademark of Cutler-Hammer Products.
 †Enclosure not suitable for NEMA 4 with cover mounted operators.

CHS Controls AB
 Tel +46 42 38 61 00, Fax +46 42 38 61 29
 chs@chscontrols.se www.chscontrols.se

Enclosure Only Cat. #	Dimensions (In Inches): A	B	C	D	F	**J Conduit Entry			
						Trade Size D&T	w/RE	K	L
EBMCFB E	25.75	24.75	26.90	6.00	14.78	2"	1.5"	3.25	3.13
EBMCFG E	38.13	36.50	39.28	6.00	14.78	3"	2.5"	3.25	3.13
EBMCFK E	43.12	41.50	42.65	12.00	20.46	(2) 3"	(2) 2.5"	3.25	3.25
EBMCFM E	64.22	62.50	64.03	12.00	21.08	(2) 4"	(2) 3.5"	4.00	4.00

*H" - Use 1/2" diameter bolts for all enclosures listed above.

**1" D&T conduit entry for control conductors supplied with PLG plug (top and bottom).

**Conduit entrance for power conductors (top & bottom). (All conduit entrances supplied with RE reducer and PLG plug.)

Ordering Information - Combination Line Starters

- To order an enclosure complete with motor starter and circuit breaker (or motor circuit protector), insert the manufacturer's symbols in the designated positions of the catalog number. Symbols are shown in the footnotes.

EBM "E" Series Combination Line Starters and Enclosures for Cutler-Hammer Advantage Starters, Single Speed Non-Reversing

Motor Starter			Circuit Breaker			Enclosure	
Max. HP Polyphase	Line Volt	NEMA Size	Amp Trip	Frame Volts	Frame Type	Without Breaker & Starter Cat. #†	With Breaker (or Motor Circuit Protector) & Cutler-Hammer Advantage Starter Cat. #
7½	240	1	50	240	FAL, TEB	EBMCFB E	EBMC1FB ①50②32 W6213 E
7½	240	1	50	480	FAL, TED, EHD	EBMCFB E	EBMC1FB ①50②34 W6213 E
7½	240	1	50	600	FAL, TED, FDB	EBMCFB E	EBMC1FB ①50②36 W6213 E
10	480	1	30	480	FAL, TED, FDB	EBMCFB E	EBMC1FB ①30②34 W6413 E
10	480	1	30	600	FAL, TED, FDB	EBMCFB E	EBMC1FB ①30②36 W6413 E
10	600	1	30	600	FAL, TED, FDB	EBMCFB E	EBMC1FB ①30②36 W6613 E
15	240	2	70	240	FAL, TEB	EBMCFB E	EBMC2FB ①70②32 W6213 E
15	240	2	70	480	FAL, TED, FDB	EBMCFB E	EBMC2FB ①70②34 W6213 E
15	240	2	70	600	FAL, TED, FDB	EBMCFB E	EBMC2FB ①70②36 W6213 E
25	480	2	70	480	FAL, TED, EHD	EBMCFB E	EBMC2FB ①70②34 W6413 E
25	480	2	70	600	FAL, TED, FDB	EBMCFB E	EBMC2FB ①70②36 W6413 E
25	600	2	50	600	FAL, TED, FDB	EBMCFB E	EBMC2FB ①50②36 W6413 E
30	240	3	125	240	FAL, TEB	EBMCFG E	EBMC3FG ①125②32 W6213 E
30	240	3	125	480	FAL, TED, EHD	EBMCFG E	EBMC3FG ①125②34 W6213 E
30	240	3	125	600	FAL, TED, FDB	EBMCFG E	EBMC3FG ①125②36 W6213 E
50	480	3	100	480	FAL, TED, EHD	EBMCFG E	EBMC3FG ①100②34 W6413 E
50	480	3	100	600	FAL, TED, FDB	EBMCFG E	EBMC3FG ①100②36 W6413 E
50	600	3	90	600	FAL, TED, FDB	EBMCFG E	EBMC3FG ①90②36 W6613 E
50	240	4	200	600	TFK, JD, KAL, TFJ, JDB	EBMCFK E	EBMC4FK ①200②W36 W6213 E
100	480	4	200	600	TFK, JD, KAL, TFJ, JDB	EBMCFK E	EBMC4FK ①200②36 W6413 E
100	600	4	150	600	TFK, JD, KAL, TFJ, JDB	EBMCFK E	EBMC4FK ①150②36 W6613 E
75	240	5	400	600	TJK, KD, LAL, TJJ, KDB	EBMCFM E	EBMC5FM ①400②36 W6213 E
150	480	5	400	600	TJK, KD, LAL, TJJ, KDB	EBMCFM E	EBMC5FM ①400②36 W6413 E
200	600	5	400	600	TJK, KD, LAL, TJJ, KDB	EBMCFM E	EBMC5FM ①400②36 W6613 E

①With Circuit Breakers:

Manufacturer	Symbol
Cutler-Hammer	WT
General Electric	TT
Square D	DT

①With Motor Circuit Protectors:

Note: Only units with a frame volts of 600 are available with Motor Circuit Protectors:

Manufacturer	Symbol
Cutler-Hammer	WP
General Electric	TP
Square D	DP

②Select Circuit Breaker Frame Type based on Frame Size, Voltage, and Manufacturer desired.

Manufacturer	100 Amp Frame and 150 Amp Frame		225 Amp Frame and 250 Amp Frame		400 Amp Frame
	240VAC	480VAC	600VAC	600VAC	
Cutler-Hammer	—	EHD	FDB	JD - Interchangeable Trip Unit JDB - Non-Interchangeable Trip Unit	KD - Interchangeable Trip Unit KDB - Non-Interchangeable Trip Unit
General Electric	TEB	TED	TED	TFK - Interchangeable Trip Unit TFJ - Non-Interchangeable Trip Unit	TJK - Interchangeable Trip Unit TJJ - Non-Interchangeable Trip Unit
Square D	FAL	FAL	FAL	KAL	LAL

②Select Motor Circuit Protector Frame Type based on Frame Size and Manufacturer desired. Before the frame type a character symbol must be entered to designate the trip range. See page 437 for appropriate symbol.

Manufacturer	150 Amp Frame (600 V)	250 Amp Frame (600 V)	400 Amp Frame (600 V)
Cutler-Hammer	HMCP (F-Frame)	HMCP (J-Frame)	HMCP (K-Frame)
General Electric	TEC	TFC	TJC
Square D	FAL	KAL	LAL



CHS Controls AB

Tel +46 42 38 61 00, Fax +46 42 38 61 29
 chs@chscontrols.se www.chscontrols.se

†Note: "Enclosures only" are supplied with necessary operators, linkages, and mercury switch electronic overload resets.

‡Enclosure not suitable for NEMA 4 with cover mounted operators.

Applications:

EPC combination line starters and enclosures are used:

- For across-the-line starting of polyphase AC induction motors
- In locations which are hazardous due to the presence of flammable vapors, gases or highly combustible dusts
- In damp, wet or corrosive locations
- For installation indoors or outdoors at petroleum refineries, chemical and petrochemical plants and other process industry facilities where similar hazards exist
- To provide disconnecting means, motor branch circuit protection, motor running protection, undervoltage protection and remote starting and stopping due to the combination of thermal-magnetic circuit breaker and magnetic motor starter

Features:

- Quick-opening covers – less than two turns to remove or install
- Three section design for ease of installation
- Water-shedding construction with female threads on top cover, male threads on bottom cover, and top cover skirted
- Specially located stops and locks insure adequate thread engagement and prevent overtightening
- Separate replaceable mounting bracket attached to the rear of the body provides three-point suspension for quick installation and leveling – one keyhole slot at top and two open slots at bottom
- Bodies have two taper-tapped conduit hubs with integral bushings on the top, and two more directly below
- Universal mounting plate and reset mechanism will accommodate any of the motor starters and circuit breakers in catalog listing
- When interior mounting plate is removed, feeder and branch circuit conductors are easily pulled into the wiring chamber. The interior assembly, with breaker and starter attached, is then replaced, final connections made, and covers assembled
- External handle, which operates breaker can be padlocked in either "ON" or "OFF" positions
- Breaker is trip-free of the handle, therefore it will open under short circuit or overload, even if the external handle is locked in the "ON" position
- Furnished with third overload relay as standard

Certifications and Compliances:

- NEC/CEC
 Class I, Division 1 & 2, Groups C, D
 Class II, Division 1, Groups E, F, G
 Class II, Division 2, Groups F, G
 Class III
- NEMA/EEMAC: 3, 4, 7CD, 9EFG, 12
- UL Standard: 698
- CSA Standards: C22.2 No. 30

Standard Materials:

- Body and cover – copper-free aluminum
- Operating handle – copper-free aluminum
- Operating shafts – stainless steel
- Interior parts – sheet steel

Standard Finishes:

- Copper-free aluminum – natural
- Stainless steel – natural
- Sheet steel – electrogalvanized with chromate finish

Electrical Rating Range:

- Starters – Sizes 0, 1 and 3 inclusive
- Breakers – 100 and 150 ampere frame sizes
- Motor Circuit Protectors – 100 ampere frame size

Options:

The following special options are available from factory by adding suffix to Cat. No. and many are available in kit form or for field addition to existing units: See page 459 for listing of kits

Description	Suffix
Control circuit transformer 600/480/240–120 volts, 50 or 60 hertz (Sizes 0 and 1 – 100–50 VA, Size 3 – 200–350 VA)	
Fusible – Secondary.....	FT
Fusible – Primary and secondary.....	FTPS
Auxiliary Contacts on Starter or Contactor*	
1 N.O./1 N.C.....	S781
2 N.O./2 N.C.....	S782
3 N.O./3 N.C.....	S783
Auxiliary Switch on Circuit Breaker or Motor Circuit Protector*	
1A/1B (1P2T).....	S784
2A/2B (2P2T).....	S785
Side bosses drilled and tapped same size as standard hubs (except 15" dia. – 1" size).....	S366
Back boss drilled and tapped same size as standard hubs (except 15" dia. – 1" size).....	S367
Pushbuttons (heavy duty): START-STOP.....	PB3

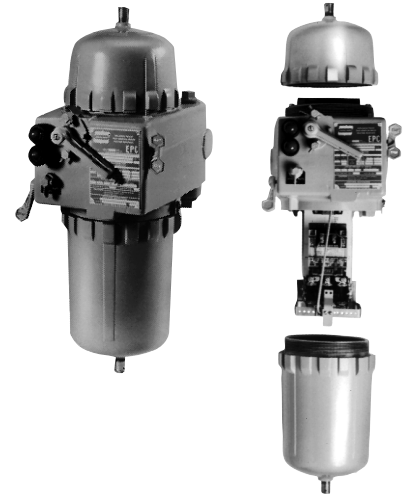

Assembled unit

Separated view showing major components

Description	Suffix
Selector switches (standard duty):	
ON-OFF.....	RR2
HAND-OFF-AUTO.....	RR3
Pilot lights:	
Red, 120 volt.....	J1
Green, 120 volt.....	J3
LED pilot lights, in place of standard incandescent lamps.....	LED
Pilot light transformers:	
240 volt†.....	T2
480 volt†.....	T4
600 volt†.....	T5
Space heaters:	
120 volt.....	R11
240 volt.....	R22
480 volt.....	R44
Automatic reset overload relay.....	S1
Less overload relays (lighting contactor).....	CL
Less overload relays (motor contactor)	CM
Separate AC control circuit.....	Specify
Insulated neutral with 2 connectors (50, 100 & 225 amp).....	S146
Grounded neutral stud with 3 connectors (50, 100 & 225 amp).....	S178
Pilot light holes drilled, tapped and plugged for future addition of pilot lights	
One hole.....	S541
Two holes.....	S542
Standard Breather (Class I, Groups C, D, Class II, Groups E, F, G, Class III)....	S219
Standard Drain (Class I, Groups C, D, Class II, Groups E, F, G, Class III).....	S198
Standard Breather and Drain (Class I, Groups C, D, Class II, Groups E, F, G, Class III).....	S198V
Universal Breather – Drain (Class I, Groups C, D, Class II, Groups F, G).....	S454†
(2) Universal Breather – Drains (Class I, Groups C, D, Class II, Groups F, G).....	S454V†
Less heaters.....	0

*Application is limited by starter, contactor, circuit breaker or motor circuit protector design – Consult Factory
 † Required for pilot lights on other than 120 volt control circuits. One required for each lamp.
 ‡ Not suitable for NEMA 4.

1C



CHS Controls AB
 Tel +46 42 38 61 00, Fax +46 42 38 61 29
 chs@chscontrols.se www.chscontrols.se

EPC Combination Line Starters and Enclosures

Dimensions* (In Inches)

Cl. I, Div. 1 & 2, Groups C, D
 Cl. II, Div. 1, Groups E, F, G
 Cl. II, Div. 2, Groups F, G
 Cl. III
 NEMA 3, 4, 7CD, 9EFG, 12

Explosionproof
 Dust-Ignitionproof
 Raintight
 Wet Locations
 Watertight

1C

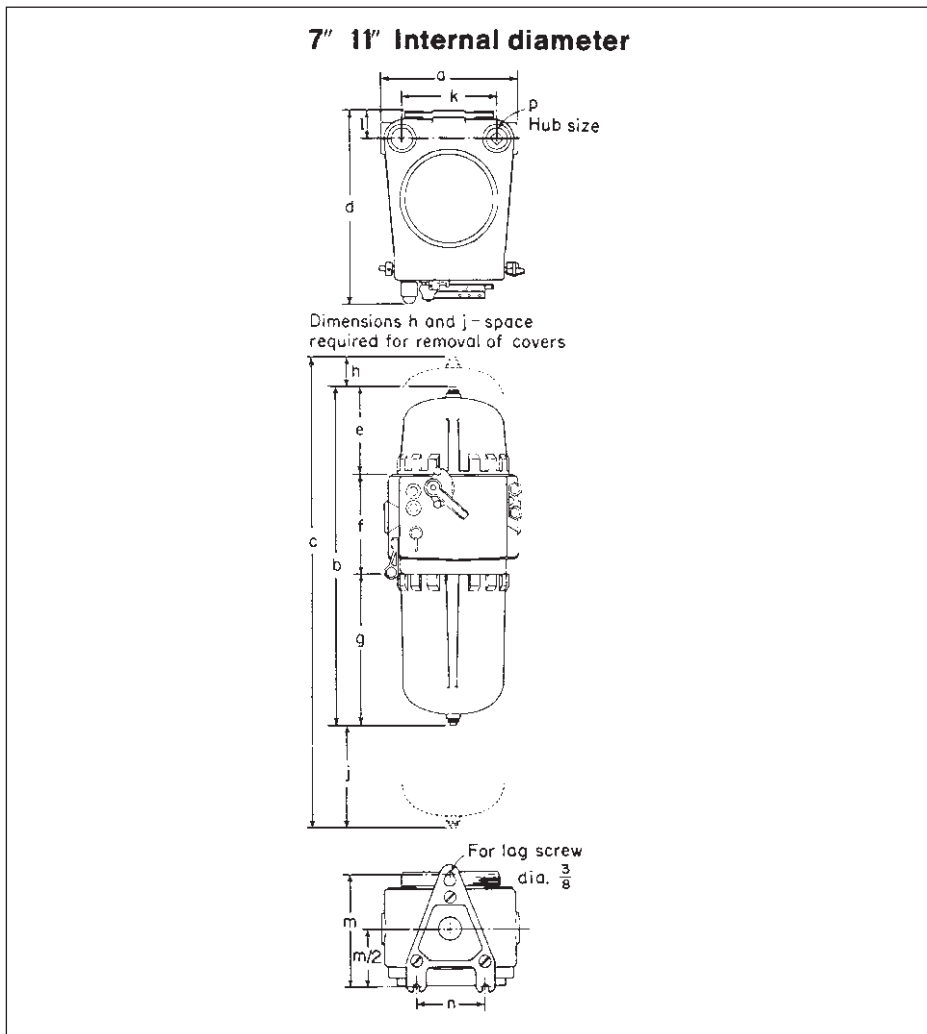

Single-Speed Non-Reversing Sizes 0, 1 and 3 starters

	EPC87	EPC813	EPC87-FTPS or EPC87-FT	EPC813-FTPS or EPC813-FT
Int. Dia.	7"	11"	7"	11"
	Dimensions		Dimensions†	
a	10 ⁵ / ₈	16 ¹ / ₈	10 ⁵ / ₈	16 ¹ / ₈
b	26 ¹ / ₁₆	38 ¹ / ₂	31 ¹ / ₁₆	41 ¹ / ₂
c	35 ¹¹ / ₁₆	61	47 ¹¹ / ₁₆	67 ¹ / ₂
d	14 ¹¹ / ₁₆	20 ¹ / ₄	14 ¹¹ / ₁₆	20 ¹ / ₄
e	6 ³ / ₄	9 ¹ / ₈	11 ³ / ₄	12 ¹ / ₈
f	71 ¹ / ₁₆	8 ⁵ / ₈	71 ¹ / ₁₆	8 ⁵ / ₈
g	11 ⁵ / ₈	20 ³ / ₄	11 ⁵ / ₈	20 ³ / ₄
h	2	4 ¹ / ₂	9	8
j	7 ⁵ / ₈	18	7 ⁵ / ₈	18
k	7 ³ / ₈	12	7 ³ / ₈	12
l	2 ¹ / ₁₆	2 ⁵ / ₈	2 ¹ / ₁₆	2 ⁵ / ₈
m	9 ³ / ₈	11	9 ³ / ₈	11
n	5 ¹ / ₄	5 ¹ / ₂	5 ¹ / ₄	5 ¹ / ₂
p	1 ¹ / ₄	2 ¹ / ₂	1 ¹ / ₄	2 ¹ / ₂

*Dimensions are approximate, not for construction purposes.
 †For units with Control Circuit Transformer (suffix FT or FTPS).



CHS Controls AB

Tel +46 42 38 61 00, Fax +46 42 38 61 29
 chs@chscontrols.se www.chscontrols.se

EPC Combination Line Starters and Enclosures

Single Speed, Non-Reversing with Circuit Breakers

3-Pole 60 hertz, 600 VAC Maximum

Cl. I, Div. 1 & 2, Groups C, D Explosionproof
 Cl. II, Div. 1, Groups E, F, G Dust-Ignitionproof
 Cl. II, Div. 2, Groups F, G Raintight
 Cl. III Wet Locations
 NEMA 3, 4, 7CD, 9EFG, 12 Watertight

Ordering Information:

To order an enclosure complete with starter and breaker, insert the manufacturer's symbols in the designated positions of the catalog number. Symbols are shown in the footnotes below.

Enclosures only can be ordered. Select from listings below.

Instantaneous magnetic trip circuit breakers (magnetic circuit interrupters) can be supplied. Consult factory.

Select the complete Cat. No. below and specify HP, voltage, frequency, RPM, type and full load ampere rating of motor – or specify ampere rating of heaters.

For combination starters with motor circuit protectors or single speed, non-reversing motors see page 443.

Motor Starter		Circuit Breaker			Enclosure		Without Starter & Circuit Breaker	With Starter & Circuit Breaker
Max. HP Polyphase	Volts	NEMA Size	Amp Rating	Frame	Hub Size in.	Int. Dia. in.	Cat. #	Cat. # \$
2	120	0	30	EB	1¼	7	EPC87	EPC870 ①30ED ②613
3	240	0	20	EHD	1¼	7	EPC87	EPC870 ①20EHD ②623
3	480	0	15	EHD	1¼	7	EPC87	EPC870 ①15EHD ②643
3	480	0	15	FDB	1¼	7	EPC87	EPC870 ①15FD ②643
3	600	0	15	FD	1¼	7	EPC87	EPC870 ①15FD ②653
5	240	1	30	EHD	1¼	7	EPC87	EPC871 ①30EHD ②623
5	480	0	15	EHD	1¼	7	EPC87	EPC870 ①15EHD ②643
5	480	0	15	FDB	1¼	7	EPC87	EPC870 ①15FD ②643
5	600	0	15	FDB	1¼	7	EPC87	EPC870 ①15FD ②653
7½	240	1	50	EHD	1¼	7	EPC87	EPC871 ①50EHD ②623
7½	480	1	30	EHD	1¼	7	EPC87	EPC871 ①30EHD ②643
7½	480	1	30	FDB	1¼	7	EPC87	EPC871 ①30FD ②643
7½	600	1	30	FDB	1¼	7	EPC87	EPC871 ①30FD ②653
10	480	1	30	EHD	1¼	7	EPC87	EPC871 ①30EHD ②643
10	480	1	30	FDB	1¼	7	EPC87	EPC871 ①30FD ②643
10	600	1	30	FDB	1¼	7	EPC87	EPC871 ①30FD ②653
40	480	3	90	EHD	2½	11	EPC813	EPC813 ①90EHB ②643
40	480	3	90	FDB	2½	11	EPC813	EPC813 ①90FB ②643
40	600	3	90	FDB	2½	11	EPC813	EPC813 ①90FB ②653
50	480	3	100	EHD	2½	11	EPC813	EPC813 ①100EHB ②643
50	480	3	100	FDB	2½	11	EPC813	EPC813 ①100FB ②643
50	600	3	100	FDB	2½	11	EPC813	EPC813 ①100FB ②653

①Circuit Breakers:

Manufacturer	Symbol	Frames 100/150AMP		
		240V	480V	600V
General Electric	TT	TEB	TED*	TED*
Square D	DT	FAL*	FAL*	FAL*
Cutler-Hammer	WT	EHD	EHD	FB, FDB

*Specify Voltage

§ Starters are furnished with three heaters when heater ratings are fully specified.

②Motor Starters:

Manufacturer	Symbol
Allen-Bradley	AB
General Electric	G
Square D	D
Cutler-Hammer	W

■ When Square D starter is used in EPC813, EPC-KIT 32 must be ordered



CHS Controls AB
 Florettgatan 33
 SE-254 67 Helsingborg, Sweden
 Tel +46 42 38 61 00, Fax +46 42 38 61 29
 chs@chscontrols.se
 www.chscontrols.se

EPC Combination Line Starters

Single-Speed Non-Reversing with Motor Circuit Protectors 3-Pole 60 hertz, 600 VAC Maximum

Cl. I, Div. 1 & 2, Groups C, D
Cl. II, Div. 1, Groups E, F, G
Cl. II, Div. 2, Groups F, G
Cl. III
NEMA 3, 4, 7CD, 9EFG, 12

Explosionproof
Dust-Ignitionproof
Raintight
Wet Locations
Watertight

1C

Ordering Information:

Select the complete Catalog No. below and specify HP, voltage, frequency, RPM, type and full load ampere rating of motors or specify ampere rating of heaters.

Current limiters may be ordered by specification*.

Motor Starter			Enclosure with Motor Circuit Protector and Starter §	
Max. HP Polyphase	Volts	NEMA Size	Amp Rating	Cat. #
3	240	0	15	EPC870 ①15HMCP ②623
3	480	0	7	EPC870 ①7HMCP ②643
3	600	0	7	EPC870 ①7HMCP ②653
5	480	0	15	EPC870 ①15HMCP ②643
5	600	0	15	EPC870 ①15HMCP ②653
7½	240	1	30	EPC871 ①30HMCP ②623
7½	480	1	15	EPC871 ①15HMCP ②643
10	600	1	15	EPC871 ①15HMCP ②653
10	480	1	30	EPC871 ①30HMCP ②643

①Motor Circuit Protectors

Manufacturer	Symbol
General Electric	TP
Square D	DP
Cutler-Hammer	WP

②Motor Starters:

Manufacturer	Symbol
Allen-Bradley	AB
General Electric	G
Square D	D
Cutler-Hammer	W

*General Electric or Cutler-Hammer MCPs only.

§ Starters are furnished with three heaters when heater ratings are fully specified.

1C



CHS Controls AB
 Florettgatan 33
 SE-254 67 Helsingborg, Sweden
 Tel +46 42 38 61 00, Fax +46 42 38 61 29
chs@chscontrols.se
www.chscontrols.se

Applications:

- NMC combination magnetic line starters are for use in across-the-line motor starting, motor disconnect, motor and line protection and start-stop operations.

Features:

- Enclosures are made of *Krydon*® high impact strength fiberglass-reinforced polyester material having excellent corrosion resistance and stability to heat.
- Unitized, strong and durable enclosure construction provides longer service life for equipment.
- Provided with top and bottom mounting feet.
- Enclosure has hinged access door which opens 160° for easy wiring and maintenance. Three screws for door frame are hidden behind access door.
- Access door may be padlocked to prevent unauthorized access.

Certifications and Compliances:

- NEMA/EEMAC: 3, 4X and 12

Electrical Rating Ranges:

- 3-pole, 60 hertz, 600 VAC max.
- Starters – sizes 0, 1, 2, 3, 4
- Breakers – 100, 150, 225 and 250 amp frame
- Switches – 30, 60, 100 amp
- Motor circuit protectors – 15, 30, 50, 100, 150 amp



Combination line starter with optional START-STOP pushbuttons – open view



Combination line starter with optional START-STOP pushbuttons – closed view

Options:

Description	Suffix
Control circuit transformer 480/240-120 volts, 50 or 60 hertz, (Sizes 0 and 1 – 50VA, Size 2 – 100VA, Size 3 – 150VA, Size 4 – 300VA)	
Fusible	
Secondary.....	FT
Primary and secondary.....	FTPS
Auxiliary Contact on Starter or Contactor*	
1NO/1NC.....	S781
2 NO/2 NC.....	S782
3 NO/3 NC.....	S783
Auxiliary Switch on Circuit Breaker or Motor Circuit Protector*	
1A/1B	S784
2A/2B	S785
Time delay low voltage release for 3-wire control with 2, 4 or 6- second adjustment. For single- speed, non-reversing starters only. Control circuit voltage:	
120 volt, 60 hertz.....	LVR1†
240 volt, 60 hertz.....	LVR2†
480 volt, 60 hertz.....	LVR4†

Description

Description	Suffix
Pilot lights, 120 V primary – specify other primary voltages as required:	
Red pilot light.....	J1
Green pilot light.....	J3
LED pilot lights in place of standard incandescent pilot lamps	LED
Pushbutton (heavy duty, uses two device holes):	
START-STOP.....	PB13
Selector Switch (heavy duty)	
ON-OFF.....	RR17
HAND-OFF-AUTO.....	RR18
JOG-RUN-OFF.....	RR19
Padlock attachment for:	
Pushbutton.....	S708
Automatic reset overload relay.....	S1
Less overload relays (contactor).....	C
Separate AC control circuit.....	Specify
Insulated, groundable type terminal block for grounded or ungrounded neutral can be supplied.....	S618
Hubs (see "NOTE ON HUBS") – see page 646	
Grounding plate or bushing – see page 646	

*Application limited by Size 5 starter, contactor or circuit breaker design – consult factory.
†Option not available on NMC1024B.

NOTE ON HUBS: The following number and sizes of hubs (not mounted) are included when combination starters are ordered complete. If enclosures only are ordered, hubs must be ordered separately (see "Options").

Starter Size	Number Included	Hub Size
0	3	3/4
1	1 2	3/4 1
2	1 2	3/4 1 1/2
3	1 2	3/4 2
4	1 2	3/4 2 1/2

CHS Controls AB

Florettgatan 33
SE-254 67 Helsingborg, Sweden
Tel +46 42 38 61 00, Fax +46 42 38 61 29
chs@chscontrols.se
www.chscontrols.se



NMC Combination Line Starters and Enclosures

Single-Speed, Non-Reversing
600VAC Heavy Duty

Corrosion-Resistant
Dust-tight
Watertight
Weatherproof
NEMA 3, 4X, 12

1C

Ordering Information - With Circuit Breakers

To order an enclosure complete with starter and breaker, insert the manufacturer's symbols in the designated positions of the catalog number. Symbols are shown in the footnotes.

Select the complete Cat. No. below and specify HP, voltage, frequency, RPM, type and full load ampere rating of motor – or specify ampere rating of heaters. Starters are furnished with three heaters.

Enclosures only can be ordered. Select from listings below. Specific reference table is shown in the listings below. Instantaneous magnetic trip circuit breakers (magnetic circuit interrupters) can be supplied.

Motor Starter			Circuit Breaker		Enclosure	
Max. HP Polyphase	Volts (A-C)	NEMA Size	Trip Setting Amps	Frame	With Starter & Circuit Breaker Cat. #	Without Starter & Circuit Breaker Cat. #
2	120	0	30	EB	NMC1024B ①30EB ②6130	NMC1024B
2	240	0	15	EB	NMC1024B ①15EB ②6230	NMC1024B
3	240	0	20	EB	NMC1024B ①20EB ②6230	NMC1024B
5	240	1	30	EB	NMC1024B ①30EB ②6231	NMC1024B
5	480	0	15	EHD	NMC1024B ①15EHB ②6430	NMC1024B
5	600	0	15	FDB	NMC1024B ①15FB ②6530	NMC1024B
7½	240	1	50	EB	NMC1024B ①50EB ②6231	NMC1024B
7½	480	1	20	EHD	NMC1024B ①20EHB ②6431	NMC1024B
7½	600	1	20	FDB	NMC1024B ①20FB ②6531	NMC1024B
10	240	2	60	EB	NMC1024B2 ①60EB ②6232	NMC1024B2
10	480	1	30	EHD	NMC1024B ①30EHB ②6431	NMC1024B
10	600	1	30	FDB	NMC1024B ①30FB ②6531	NMC1024B
15	240	2	80	EB	NMC1024B2 ①80EB ②6232	NMC1024B2
15	480	2	40	EHD	NMC1024B2 ①40EHB ②6432	NMC1024B2
15	600	1	40	FDB	NMC1024B ①40FB ②6531	NMC1024B
20	240	3	80	EB	NMC1426B ①80EB ②6233	NMC1426B
20	480	2	60	EHD	NMC1024B2 ①60EHB ②6432	NMC1024B2
20	600	2	50	FDB	NMC1024B2 ①50FB ②6532	NMC1024B2
25	240	3	80	EB	NMC1426B ①80EB ②6233	NMC1426B
25	480	2	70	EHD	NMC1024B2 ①70EHB ②6432	NMC1024B2
25	600	2	60	FDB	NMC1024B2 ①60FB ②6532	NMC1024B2
30	240	4	125	JDB‡	NMC2426B ①125JB ②6234	NMC2426B
30	480	3	80	EHD	NMC1426B ①80EHB ②6433	NMC1426B
30	600	3	60	FDB	NMC1426B ①60FB ②6533	NMC1426B
40	240	4	150	JDB‡	NMC2426B ①150JB ②6234	NMC2426B
40	480	3	80	EHD	NMC1426B ①80EHB ②6433	NMC1426B
40	600	3	80	FDB	NMC1426B ①80FB ②6533	NMC1426B
50	240	4	200	JDB‡	NMC2426B ①200JB ②6234	NMC2426B
50	480	3	100	EHD	NMC1426B ①100EHB ②6433	NMC1426B
50	600	3	100	FDB	NMC1426B ①100FB ②6533	NMC1426B
60	480	4	125	JDB‡	NMC2426B ①125JB ②6434	NMC2426B
60	600	4	100	JDB‡	NMC2426B ①100JB ②6534	NMC2426B
75	480	4	150	JDB‡	NMC2426B ①150JB ②6434	NMC2426B
75	600	4	125	JDB‡	NMC2426B ①125JB ②6534	NMC2426B
100	480	4	175	JDB‡	NMC2426B ①175JB ②6434	NMC2426B
100	600	4	150	JDB‡	NMC2426B ①150JB ②6534	NMC2426B

①Circuit Breakers:

②Motor Starters:

Manufacturer	Symbol	Frames			
		100/150A	240V	480V	600V
General Electric	TT	TEB	TED§	TED§	TFJ
Square D	DT	FAL§	FAL§	FAL§	KAL
Cutler-Hammer	WT	EB	EHB, EHD	FB, FDB	JB, JDB

Manufacturer	Symbol
Allen-Bradley	AB
General Electric	G
Square D	D
Cutler-Hammer	W

Information on other starter manufacturers on request.

NOTE ON HUBS: See page 444.

§Specify voltage.

‡Formerly "JB"

CHS Controls AB
 Florettgatan 33
 SE-254 67 Helsingborg, Sweden
 Tel +46 42 38 61 00, Fax +46 42 38 61 29
 chs@chscontrols.se
 www.chscontrols.se



NMC Combination Line Starters and Enclosures

Single-Speed, Non-Reversing
600VAC Heavy Duty

Corrosion-Resistant
Dust-tight
Watertight
Weatherproof
NEMA 3, 4X, 12

Ordering Information - With Motor Circuit Protector

Motor Starter			Enclosure		
Max. HP Polyphase	Volts (AC)	NEMA Size	MCP Trip Setting Amps	With Starter & MCP Cat. #§	Without Starter & MCP Cat. #
3	240	0	15	NMC1024B ①15MCP ②6230	NMC1024B
5	480	0	15	NMC1024B ①15MCP ②6430	NMC1024B
5	600	0	15	NMC1024B ①15MCP ②6530	NMC1024B
7½	240	1	30	NMC1024B ①30MCP ②6231	NMC1024B
10	480	1	30	NMC1024B ①30MCP ②6431	NMC1024B
10	600	1	30	NMC1024B ①30MCP ②6531	NMC1024B
15	240	2	50	NMC1024B2 ①50MCP ②6232	NMC1024B2
25	480	2	50	NMC1024B2 ①50MCP ②6432	NMC1024B2
25	600	2	50	NMC1024B2 ①50MCP ②6532	NMC1024B2
30	240	3	100	NMC1426B ①100MCP ②6233	NMC1426B
50	480	3	100	NMC1426B ①100MCP ②6433	NMC1426B
50	600	3	100	NMC1426B ①100MCP ②6533	NMC1426B
50	240	4	150	NMC2426P ①150MCP ②6234	NMC2426P
100	480	4	150	NMC2426P ①150MCP ②6434	NMC2426P
100	600	4	150	NMC2426P ①150MCP ②6534	NMC2426P

①Motor Circuit Protectors:

Manufacturer	Symbol
General Electric	G
Cutler-Hammer	W

②Motor Starters:

Manufacturer	Symbol
Allen-Bradley	AB
Square D	D
General Electric	G
Cutler-Hammer	W

NOTE ON HUBS: See page 444.

§ With motor circuit protector only. For motor circuit protector with current limiter – information on request.

Information on other starter manufacturers on request.

Ordering Information - With Non-fusible Disconnect Switch

To order an enclosure complete with disconnect switch, insert the manufacturer's symbol in the designated positions of the catalog number. Symbols are shown in the footnotes.

Enclosures only can be ordered. Select from listings below.

Motor Starter			Non-fusible Disconnect Switch	Enclosure	
Max. HP Polyphase	Volts (AC)	NEMA Size	Switch Size-Amps	With Starter & Disconnect Switch Cat. #	Without Starter & Disconnect Switch Cat. #
3	240	0	30	NMC1024D ①30 ②6230	NMC1024D ①
5	480	0	30	NMC1024D ①30 ②6430	NMC1024D ①
5	600	0	30	NMC1024D ①30 ②6530	NMC1024D ①
7½	240	1	30	NMC1024D ①30 ②6231	NMC1024D ①
10	480	1	30	NMC1024D ①30 ②6431	NMC1024D ①
10	600	1	30	NMC1024D ①30 ②6531	NMC1024D ①
15	240	2	60	NMC1426D ①60 ②6232	NMC1426D ①
25	480	2	60	NMC1426D ①60 ②6432	NMC1426D ①
25	600	2	60	NMC1426D ①60 ②6532	NMC1426D ①
30	240	3	100	NMC2426D ①100 ②6233	NMC2426D ①
50	480	3	100	NMC2426D ①100 ②6433	NMC2426D ①
50	600	3	100	NMC2426D ①100 ②6533	NMC2426D ①

①Disconnect Switches:

Manufacturer	Symbol	Switch Type
General Electric	G	Type QMW
Square D	D	Class 9422
Cutler-Hammer	W	Type DS

②Motor Starters:

Manufacturer	Symbol
Allen-Bradley	AB
Square D	D
General Electric	G
Cutler-Hammer	W

NOTE ON HUBS: See page 444.

Information on other starter manufacturers on request.



CHS Controls AB

Tel +46 42 38 61 00, Fax +46 42 38 61 29
chs@chscontrols.se www.chscontrols.se

NMC Combination Line Starters and Enclosures

Single-Speed, Non-Reversing
600VAC Heavy Duty

Corrosion-Resistant
Dust-tight
Watertight
Weatherproof
NEMA 3, 4X, 12

1C

Ordering Information - With Fusible Disconnect Switch

Motor Starter			Fusible Disconnect Switch		Enclosure	
Max. HP Polyphase	Volts AC	NEMA Size	Switch Size-Amps	Fuse Clip Rating-Amps	With Starter & Disconnect Switch Cat. #■	Without Starter & Disconnect Switch Cat. #
3	240	0	30	30	NMC1024D ①3030 ②6230	NMC1024D ①
5	480	0	30	30	NMC1024D ①3030 ②6430	NMC1024D ①
5	600	0	30	30	NMC1024D ①3030 ②6530	NMC1024D ①
7½	240	1	30	30	NMC1024D ①3030 ②6231	NMC1024D ①
7½	240	1	30	60	NMC1024D ①3060 ②6231	NMC1024D ①
10	480	1	30	30	NMC1024D ①3030 ②6431	NMC1024D ①
10	480	1	30	60	NMC1024D ①3060 ②6431	NMC1024D ①
10	600	1	30	30	NMC1024D ①3030 ②6531	NMC1024D ①
10	600	1	30	60	NMC1024D ①3060 ②6531	NMC1024D ①
15	240	2	60	60	NMC1426D ①6060 ②6232	NMC1426D ①
15	240	2	60	100	NMC1426D ①6010 ②6232	NMC1426D ①
25	480	2	60	60	NMC1426D ①6060 ②6432	NMC1426D ①
25	480	2	60	100	NMC1426D ①6010 ②6432	NMC1426D ①
25	600	2	60	60	NMC1426D ①6060 ②6532	NMC1426D ①
25	600	2	60	100	NMC1426D ①6010 ②6532	NMC1426D ①
30	240	3	100	100	NMC2426D ①1010 ②6233	NMC2426D ①
50	480	3	100	100	NMC2426D ①1010 ②6433	NMC2426D ①
50	480	3	100	200	NMC2426D ①1020 ②6433	NMC2426D ①
50	600	3	100	100	NMC2426D ①1010 ②6533	NMC2426D ①

①Disconnect Switches:

Manufacturer	Switch Type	Symbol
General Electric	Type QMW	G
Square D	Class 9422	D
Cutler-Hammer	Type DS	W

NOTE ON HUBS: See page 444.

■Fuse clips are arranged for Class H fuses and field modifiable for Class J fuses. For Class R fuses, consult Cooper Crouse-Hinds.

②Motor Starters:

Manufacturer	Symbol
Allen-Bradley	AB
Square D	D
General Electric	G
Cutler-Hammer	W

Information on other starter manufacturers on request.



CHS Controls AB
 Florettgatan 33
 SE-254 67 Helsingborg, Sweden
 Tel +46 42 38 61 00, Fax +46 42 38 61 29
 chs@chscontrols.se
 www.chscontrols.se

Dimensions In Inches:

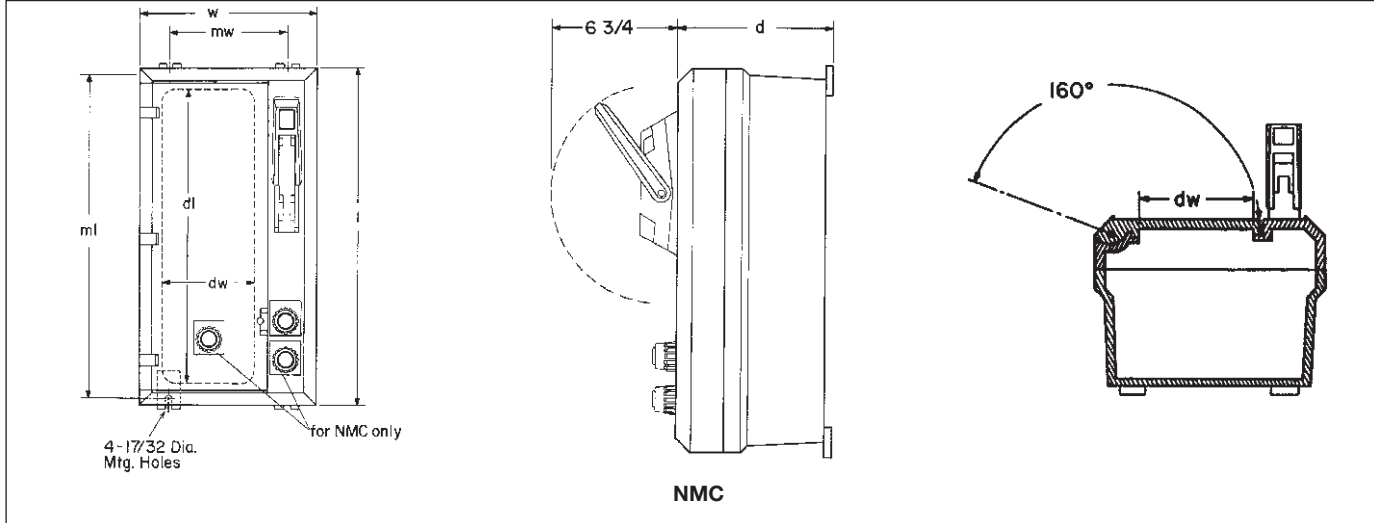

Cat. #	Outside Dimensions			Mounting Dimensions		Door Opening Dimensions	
	l	w	d	mw	ml	dl	dw
NMC1024	25 ^{13/32}	11 ^{13/32}	8 ^{23/32}	7 ^{7/8}	25 ^{3/8}	22 ^{7/8}	5 ^{11/16}
NMC1426	27 ^{13/32}	15 ^{13/32}	9 ^{23/32}	11 ^{7/8}	27 ^{1/4}	23 ^{11/16}	9 ^{11/16}
NMC2426	27 ^{13/32}	25 ^{13/32}	9 ^{23/32}	21 ^{3/4}	27 ^{1/4}	23 ^{11/16}	19 ^{11/16}

1C



CHS Controls AB
 Florettgatan 33
 SE-254 67 Helsingborg, Sweden
 Tel +46 42 38 61 00, Fax +46 42 38 61 29
 chs@chscontrols.se
 www.chscontrols.se

Description	Page No.
Application/Selection	see page 450
Magnetic Line Starters & Enclosures	
Single speed, non-reversing	
EBMS Series	see pages 451–452
EPC Series	see pages 457–458
EBMC Series with Advantage* Starter	see pages 455–456
NMG Series	see pages 472–473
Manual Line Starters & Enclosures	
EMN Series	see page 460
NMN Series	see page 471
Manual Motor Starting Switches & Enclosures	
EFD Series	see page 461
MC Series	see page 467
EDS Series	see page 462
GHG 635 Series	see pages 465–466
NSSC / NFSC	see page 469
Special Feature Kits	
For EPC Series	see page 459

*Advantage is a trademark of Cutler-Hammer Inc.

2C



CHS Controls AB
 Florettgatan 33
 SE-254 67 Helsingborg, Sweden
 Tel +46 42 38 61 00, Fax +46 42 38 61 29
 chs@chscontrols.se
 www.chscontrols.se

Application and Selection Quick Selector Chart

Applications:

Line starters are housed in enclosures suitable for specific environments, and are used for:

- Across-the-line starting of motors
- Motor running protection
- Undervoltage protection
- Remote or manual starting and stopping

Selection:

Considerations for selection of proper enclosure:

- The environment of the enclosure location in accordance with NEC/CEC and NEMA/EEMAC requirements
- The characteristics of the starter to be enclosed
- See "Quick-Selector" below for guidance

Options:

Many options are available on:

- Material and finishes where special atmospheric conditions prevail
- Special features for specific applications. See individual listings for available options, many of which are available in kit form for field addition to existing units.

Quick Selector Chart

Enclosures for Starters							
Enclosures	NEC/CEC – Hazardous Area Compliance	NEMA/EEMAC Enclosure Type	Starter Type	NEMA/EEMAC Size Starters Single Speed Non-reversing	Motor Phase and Type	Manufacturers Equipment Enclosed – Starter	Cover Type
MC	None	3, 4, 12	Manual		Single-AC	Cutler-Hammer	Gasketed
EPC	Cl. I, Div. 1 & 2, Groups C, D Cl. II, Div. 1, Groups E, F, G Cl. II, Div. 2, Groups F, G Cl. III	3, 4, 7CD, 9EFG, 12	Magnetic	0-2	Poly-AC	Allen-Bradley Cutler-Hammer G.E. Square D	Threaded
EBMS	Cl. I, Div. 1 & 2, Groups B, C, D Cl. II, Div. 1, Groups E, F, G Cl. II, Div. 2, Groups F, G Cl. III	3, 4, 7BCD, 9EFG, 12	Magnetic	0-5	Poly-AC	Allen-Bradley G.E. Square D Cutler-Hammer	Bolted/ Ground Joint/ Gasketed
EMN	Cl. I, Div. 1 & 2, Groups C, D Cl. II, Div. 1, Groups E, F, G Cl. II, Div. 2, Groups F, G Cl. III	3, 7CD, 9EFG, 12	Manual	0-1P	Single and Poly-AC	Allen-Bradley Cutler-Hammer G.E. Square D	Bolted/ Ground Joint
EDS, EDSC‡	Cl. I, Div. 1 & 2, Groups B*, C, D Cl. II, Div. 1, Groups E, F, G Cl. II, Div. 2, Groups F, G Cl. III	3, 7CD, 9EFG, 12	Manual		DC and Single AC	Allen-Bradley G.E. Cutler-Hammer	Bolted/ Ground Joint
EFD	Cl. I, Div. 1 & 2, Groups B, C, D Cl. II, Div. 1, Groups E, F, G Cl. II, Div. 2, Groups F, G Cl. III	3, 7BCD, 9EFG, 12	Manual		DC and Single and Poly-AC	G.E. Square D	Bolted/ Ground Joint
NSSC / NFSC	None	3, 4X, 12	Manual		DC and Single and Poly-AC	Allen-Bradley G.E. Square D Cutler-Hammer	Screw and gasket
NMN	None	3, 4X, 12	Manual	0-1P	Single AC	Allen-Bradley G.E. Square D	Screw and gasket
NMG	None	3, 4X, 12	Manual	0-4	Poly-AC	Allen-Bradley G.E. Square D Cutler-Hammer Westinghouse	Hinged, screw and gasket

*Check listings for Group B suitability.

‡For factory sealed units see pages 522-523.



CHS Controls AB
 Florettgatan 33
 SE-254 67 Helsingborg, Sweden
 Tel +46 42 38 61 00, Fax +46 42 38 61 29
 chs@chscontrols.se
 www.chscontrols.se

Applications:

Spectrum™ EBM hinged cover motor control enclosures are used:

- For general motor control – indoors or outdoors – in damp, wet, dirty, dusty hazardous locations, without the need for a protective shelter.
- In areas where frequent washdowns are necessary or where heavy rain or water spray is prevalent.
- For across-the-line starting, stopping, speed changing and reversing of polyphase AC induction motors.
- To provide motor overload and undervoltage protection.
- On switchracks or other assemblies where it's desired that motor control be centrally located.

Features:

- Rugged, corrosion resistant, cast copper-free aluminum construction (less than 0.4 of 1%).
- Motor starter operating handle located through the right side wall of the body permits visual confirmation of correct component assembly and operation.
- Total compliance to the wiring end room requirements of the National Electrical Code® and Canadian Electrical Code.
- Semi-clamshell enclosure design, with an external flanged ground joint between body and cover makes interior components more accessible.
- Minimum enclosure-to-enclosure spacing with little interference between the opened cover and an adjacent enclosure.
- Copper-free aluminum hinges allow the cover to swing well out of the way.
- Stainless steel, quick release, captive, hex head cover bolts. Stainless steel springs provide clear indication cover bolts are fully retracted from body.
- Versatile, internal operating mechanisms allow for field adjustment to accommodate popular manufacturers' starters.
- Simple, straightforward installation of starter on pre-drilled mounting plate within enclosure. Mounting plate also field removable.
- Neoprene cover gasket permanently attached to the cover seals out moisture.
- Bodies have top and bottom drilled and tapped entrances for power conduits plus one at the bottom for control conduit. Removable reducers are supplied as standard, to accommodate smaller size conduits. All conduit entrances are plugged.
- Tap-on mounting feet.
- Optional EMPS control devices may be added to enclosure cover.
- Steel bracket for lifting larger enclosures during installation supplied as standard.



Spectrum EBM motor control enclosures accommodate popular makes of starters.

Certifications and Compliances:

- NEC/CEC
Class I, Division 1 & 2, Groups B, C, D
Class II, Division 1, Groups E, F, G
Class II, Division 2, Groups F, G
Class III
- UL Standards: UL1203
- NEMA: 3, 3R, 4 \ddagger , 7BCD, 9EFG, 12
- CSA Standard: C22.2 No. 30

Standard Materials:

- Body and cover – copper-free aluminum
- Operating handle – copper-free aluminum
- Operating shaft and bushing – stainless steel
- Interior parts – sheet steel, electrogalvanized
- Cover bolts, washers and retractile springs – stainless steel

Electrical Rating Range:

- Motor starters – NEMA/EEMAC sizes 0–5

\ddagger Enclosure not suitable for NEMA 4 with cover mounted operators.

National Electrical Code is a Registered Trademark of the National Fire Protection Association.



CHS Controls AB
Florettgatan 33
SE-254 67 Helsingborg, Sweden
Tel +46 42 38 61 00, Fax +46 42 38 61 29
chs@chscontrols.se
www.chscontrols.se

Options:

The following options are available from the factory by adding suffix to catalog number. Suffixes are added alphanumerically.

Catalog Number System Example

EBMS1FB-①-W6413-②

- ① Options in this position are additions to the enclosures and should be listed alphanumerically.
- ② Options in this position are modifications to the motor starter and should be listed alphanumerically.

Description	Position in Cat. #	Suffix
• Less Overload Relays (lighting contactor)	①	CL
• Less Overload Relays (motor contactor)	①	CM
• Control Circuit Transformer, 100VA for NEMA/EEMAC sizes 0–2, 600/480/240–120, 50 / 60 Hertz, with provision for fusing both primary leads and one secondary lead (fuses not included)	①	FTPS100
• Control Circuit Transformer, 200VA for NEMA/EEMAC size 3, 600/480/240–120, 50 / 60 Hertz, with provision for fusing both primary leads and one secondary lead (fuses not included)	①	FTPS200
• Control Circuit Transformer, 300VA for NEMA/EEMAC size 4, 5 600/480/240–120, 50 / 60 Hertz, with provision for fusing both primary leads and one secondary lead (fuses not included)	①	FTPS300
• Pilot Light, 120VAC, Red Jewel, w/blank indicating plate	①	J1 ③
• Pilot Light, 120VAC, Green Jewel, w/blank indicating plate	①	J3 ③
• Less Heaters in Starter Overload Relay	②	0
• Start-Stop Pushbuttons (requires 2 spaces)	①	PB23 ③ \ddagger
• On-Off Selector Switch	①	RR2 ③ \ddagger
• Hand-Off-Auto Selector Switch	①	RR3 ③ \ddagger
• Space Heater, 120 Volt, 25 Watts	①	R11
• Space Heater, 240 Volt, 25 Watts	①	R22
• Space Heater, 480 Volt, 25 Watts	①	R44
• Automatic Reset Overload Relay	①	S1
• Std. Drain, Class I, B, C&D; Class II, EF&G; Class III	①	S756 \ddagger
• Std. Breather & Drain, Class I, B, C&D; Class II, EF&G; Class III	①	S756V \ddagger
• External Epoxy Finish	①	S752
• Internal and External Epoxy Finish	①	S753
• Additional control contacts, N.O. or N.C. – for single speed, non-reversing starters only (number limited by design of starter. Details on specific makes and sizes on request.)		
Aux. Contacts on starter 1 N.O. & 1 N.C.....	②	S781
Aux. Contacts on starter 2 N.O. & 2 C.....	②	S782
Aux. Contacts on starter 3 N.O. & 3 N.C.....	②	S783
12 Point Term. Block – 30 Amp, 300V	①	S786
• General Purpose Control Relay, 4 Pole N.O., contacts rated 10A @ 600V, coil 120VAC, 50–60 Hz	①	S787*

\ddagger Enclosure not suitable for NEMA 4 with cover mounted operators.

③ When specifying non-standard markings on any one of the following options with Spectrum™ EBM Motor Controls (J1, J3, PB23, RR2, RR3) it is necessary to order DSL Legend Plates for identification and marking of the device(s) being used. See page 433 for DSL Legend Plate listings.

* Use of this option with NEMA/EEMAC Size 0 or 1 starters necessitates a larger enclosure. Use "B" size enclosures.

Example:

	Enclosure	Enclosure for
Without Starter	Cat. # EBMSFA	S787 EBMSFB



CHS Controls AB
 Florettgatan 33
 SE-254 67 Helsingborg, Sweden
 Tel +46 42 38 61 00, Fax +46 42 38 61 29
 chs@chscontrols.se
 www.chscontrols.se

EBMS Magnetic Line Starters and Enclosures

**Single-Speed Non-Reversing
3-Pole 60 hertz, 600 VAC Maximum**

Cl. I, Div. 1 & 2, Groups B, C, D
Cl. II, Div. 1, Groups E, F, G
Cl. II, Div. 2, Groups F, G
Cl. III
NEMA 3, 3R, 4‡, 7BCD, 9EFG, 12

Explosionproof
Dust-Ignitionproof
Raintight
Wet Locations
Watertight

2C

Ordering Information:

- To order an enclosure complete with motor starter, insert the manufacturer's symbol in the designated position (see ‡) of the catalog number. Symbols are shown in the footnotes.
- Also specify HP, voltage, frequency, RPM, type and full load ampere rating of motor – or specify ampere rating of heaters.
- Enclosures without starters may be ordered. Select from the listings below.

EBMS Series Enclosures for Magnetic Line Starters Single Speed Non-Reversing

Motor Starter			Enclosure	
Max. HP Polyphase	Volts	NEMA Size	Without Starter Cat. #	With Starter Cat. # §
2	120	0	EBMSFA	EBMS0FA ①613
3	120	1	EBMSFA	EBMS1FA ①613
3	240	0	EBMSFA	EBMS0FA ①623
5	480	0	EBMSFA	EBMS0FA ①643
5	600	0	EBMSFA	EBMS0FA ①663
7½	120	2	EBMSFB	EBMS2FB ①613
7½	240	1	EBMSFA	EBMS1FA ①623
10	480	1	EBMSFA	EBMS1FA ①643
10	600	1	EBMSFA	EBMS1FA ①663
15	120	3	EBMSFH	EBMS3FH ①613
15	240	2	EBMSFB	EBMS2FB ①623
25	480	2	EBMSFB	EBMS2FB ①643
25	600	2	EBMSFB	EBMS2FB ①663
30	240	3	EBMSFH	EBMS3FH ①623
50	480	3	EBMSFH	EBMS3FH ①643
50	600	3	EBMSFH	EBMS3FH ①663
50	240	4	EBMSFH	EBMS4FH ①623
100	480	4	EBMSFH	EBMS4FH ①643
100	600	4	EBMSFH	EBMS4FH ①663
100	240	5	EBMSFL	EBMS5FL ①623
200	480	5	EBMSFL	EBMS5FL ①643
200	600	5	EBMSFL	EBMS5FL ①663

‡Enclosure not suitable for NEMA 4 with cover mounted operators.

§ Motor starters are furnished with three heaters when heater ratings are fully specified.



EBMS Series starter enclosures are available with magnetic line starters. NEMA sizes 0–5.

①Motor starters:

Manufacturer	Symbol
Allen Bradley	AB
Square D	D
General Electric	G
Cutler-Hammer	W



CHS Controls AB
 Florettgatan 33
 SE-254 67 Helsingborg, Sweden
 Tel +46 42 38 61 00, Fax +46 42 38 61 29
 chs@chscontrols.se
 www.chscontrols.se

EBMS Magnetic Line Starters and Enclosures

Dimensions (In Inches)

Cl. I, Div. 1 & 2, Groups B, C, D
 Cl. II, Div. 1, Groups E, F, G
 Cl. II, Div. 2, Groups F, G
 Cl. III
 NEMA 3, 3R, 4†, 7BCD, 9EFG, 12

Explosionproof
 Dust-Ignitionproof
 Raintight
 Wet Locations
 Watertight

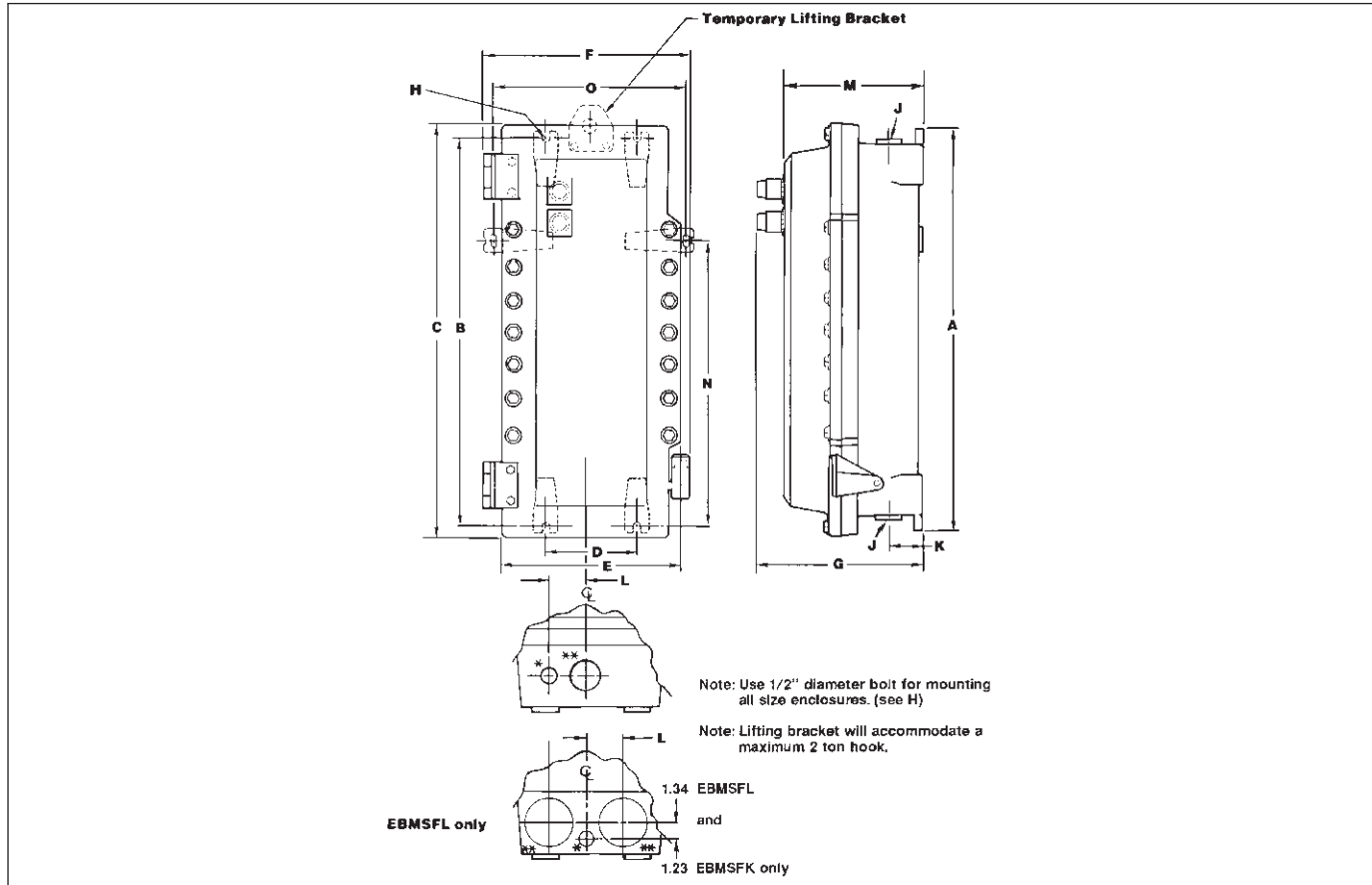

Dimensions are approximate, not for construction purposes.

Single-Speed Non-Reversing Sizes 0, 1, 2, 3, 4 and 5 Starters

Enclosure Only Cat. #	Enclosure Size Symbol	A	B	C	D	E	F	G	J** Conduit Entry		K	L	M	N	O
									Trade Size D&T■	w/RE					
Size 0,1 FVNR Starter§															
EBMSFA	A	18.25	17.25	19.00	6.00	12.63	14.38	12.13	2"	1.5"	3.25	3.13	10.25	—	—
Size 2 FVNR Starter															
EBMSFB	B	25.75	24.75	26.50	6.00	12.63	14.38	12.13	2"	1.5"	3.25	3.13	10.25	—	—
Size 3,4 FVNR Starter															
EBMSFD†	D	28.25	27.25	29.00	6.00	12.63	14.06	12.13	3"	2.5"	3.25	3.13	10.25	—	—
EBMSFH	H	37.50	36.50	38.25	6.00	14.25	16.00	13.54	3"	2.5"	3.25	3.94	11.66	—	—
Size 5 FVNR Starter															
EBMSFK†	K	43.12	41.50	42.25	12.00	17.25	19.88	11.00	(2) 3"	(2) 2.5"	3.25	3.00	10.78	—	—
EBMSFL	L	53.25	51.50	52.88	12.00	17.50	20.18	15.00	(2) 4"	(2) 3.5"	4.00	3.50	13.03	41.50	18.00

§Use EBMSFB enclosure when S787 option is ordered with size 0 or 1 starter.
 *1" Drilled & Tapped conduit entry for control conductors supplied with PLG plug (top & bottom)
 **Conduit entrance for power conductors (top and bottom). (All conduit entrances supplied with RE reducer and PLG plug.)
 †For Cutler-Hammer W200 Advantage® starters.
 ■Drilled & Tapped.
 ‡ Enclosure not suitable for NEMA 4 with cover mounted operators.



CHS Controls AB
 Florettgatan 33
 SE-254 67 Helsingborg, Sweden
 Tel +46 42 38 61 00, Fax +46 42 38 61 29
 chs@chscontrols.se
 www.chscontrols.se

Applications:

Spectrum EBM-E series of hinged cover motor control enclosures are used:

- For general motor control – indoors and outdoors – in damp, wet, dirty, dusty hazardous locations without the need for a protective shelter.
- In areas where frequent washdowns are necessary or where heavy rain or water spray is prevalent.
- For across-the-line starting and stopping of polyphase AC induction motors.
- To provide motor overload and undervoltage protection.
- On switchracks or other assemblies where it's desired that motor control be centrally located.

Features:

- Total compliance to the wiring end room requirements of the National Electrical Code®
- Solid state electronic Cutler-Hammer Advantage™ starter.
- Smaller enclosures required than for conventional starter applications.
- Elimination of heater elements, contact chatter, and welding due to low voltage supply.
- Precise overcurrent protection and constant coil power.
- Same performance and labor-saving benefits from the versatile Spectrum EBM Enclosure product line.
- Universal mounting plates and hardware for all major manufacturers' components.
- Mercury switch electronic overload reset.
- Optional EMPS control devices may be added to enclosure cover.

Certifications and Compliances:

- NEC/CEC
 - Class I, Division 1 & 2, Groups B, C, D
 - Class II, Division 1, Groups E, F, G,
 - Class II, Division 2, Groups F, G
 - Class III
- UL Standards: UL1203
- CSA Standard: C22.2 No. 30
- NEMA: 3, 3R, 4 \pm , 7BCD, 9EFG, 12

‡Enclosure not suitable for NEMA 4 with cover mounted operators. Breather and drain entries must be plugged for NEMA 4 rating.

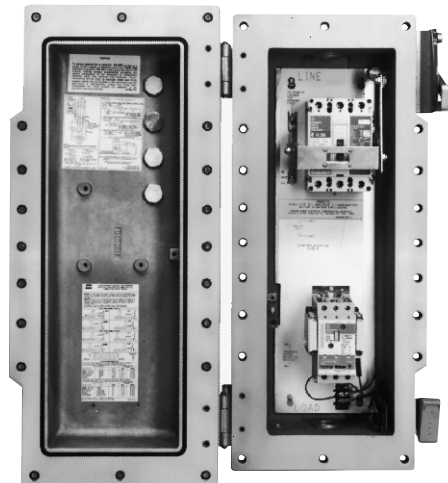

Spectrum EBM-E Series Combination Line Starter with Advantage Starter shown. Circuit breakers not provided in EBMS series.

Standard Materials:

- Body and cover – copper-free aluminum
- Operating handle – copper-free aluminum
- Operating shaft and bushing – stainless steel
- Interior parts – sheet steel, electrogalvanized
- Cover bolts, washers and retractile springs – stainless steel

Electrical Rating Range:

- Motor starters – NEMA sizes 1–5

CHS Controls AB
Florettgatan 33
SE-254 67 Helsingborg, Sweden
Tel +46 42 38 61 00, Fax +46 42 38 61 29
chs@chscontrols.se
www.chscontrols.se

2C Spectrum™ EBM Enclosures

Supplied with Cutler-Hammer Advantage™ Starters

Cl. I, Div. 1 & 2, Groups B, C, D
 Cl. II, Div. 1, Groups E, F, G
 Cl. II, Div. 2, Groups F, G
 Cl. III
 NEMA 3, 3R, 4, 4 \ddagger , 7BCD, 9EFG, 12

Explosionproof
 Dust-Ignitionproof
 Raintight
 Wet Locations
 Watertight

Dimensions In Inches:

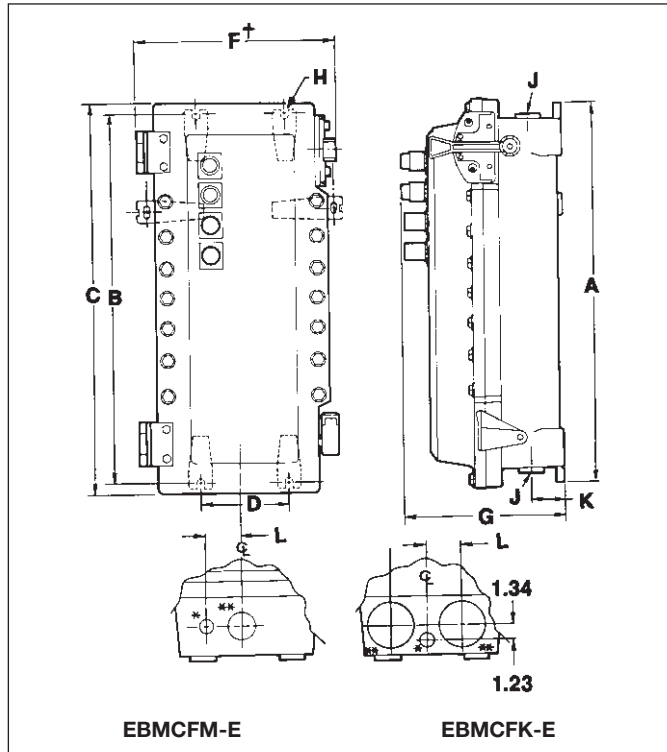

Ordering Information – Starters

- To order an enclosure, determine the electrical requirements of the system and locate the corresponding catalog number from the chart below.
- Enclosures can be ordered without starters, universal mounting plates with templates will still be provided.

EBM "E" Series Enclosures for Cutler-Hammer Advantage Starters Single Speed, Non-Reversing

Motor Starter			Enclosure	
Max. HP Polyphase	Volts	NEMA Size	Without Starter Cat. # §	With Starter Cat. #
7½	240	1	EBMSFA E	EBMS1FA W6213 E
10	480	1	EBMSFA E	EBMS1FA W6413 E
10	600	1	EBMSFA E	EBMS1FA W6613 E
15	240	2	EBMSFA E	EBMS2FA W6213 E
25	480	2	EBMSFA E	EBMS2FA W6413 E
25	600	2	EBMSFA E	EBMS2FA W6613 E
30	240	3	EBMSFD E	EBMS3FD W6213 E
50	240	4	EBMSFD E	EBMS4FD W6213 E
50	480	3	EBMSFD E	EBMS3FD W6413 E
50	600	3	EBMSFD E	EBMS3FD W6613 E
100	240	5	EBMSFK E	EBMS5FK W6213 E
100	480	4	EBMSFD E	EBMS4FD W6413 E
100	600	4	EBMSFD E	EBMS4FD W6613 E
200	480	5	EBMSFK E	EBMS5FK W6413 E
200	600	5	EBMSFK E	EBMS5FK W6613 E

Options: (Starter only)

- See page 439 for options for the EBM enclosures supplied with Cutler-Hammer Advantage starters. The following suffixes cannot be ordered with this style equipment: 0, S1.

Enclosure Only Cat. #	Dimensions In Inches:						**J Conduit Entry Trade Size			
	A	B	C	D	F	G	D&T†	w/RE	K	L
EBMSFA E	18.25	17.25	19.40	6.00	14.78	12.13	2"	1.5"	3.25	3.13
EBMSFD E	28.25	27.25	29.40	6.00	14.46	12.13	3"	2.5"	3.25	3.13
EBMSFK E	43.12	41.50	42.65	12.00	20.58	15.00	(2) 3"	(2) 2.5"	2.50	3.00

"H" – Use ½" diameter bolts for all enclosures listed above.

†1" Drilled & Tapped conduit entry for control conductors supplied with PLG plug (top & bottom).

**Conduit entrance for power conductors (top & bottom). (All conduit entrances supplied with RE reducer and PLG plug.)

†Drilled & Tapped.

‡ Enclosure not suitable for NEMA 4 with cover mounted operators. Breather and drain entries must be plugged for NEMA 4 rating.

§ Note: "Enclosures only" are supplied with necessary operators, linkages, and mercury switch electronic overload resets.

Dimensions are approximate, not for construction purposes.



CHS Controls AB
 Florettgatan 33
 SE-254 67 Helsingborg, Sweden
 Tel +46 42 38 61 00, Fax +46 42 38 61 29
 chs@chscontrols.se
 www.chscontrols.se

EPC Magnetic Line Starters and Enclosures

Cl. I, Div. 1 & 2, Groups C, D
 Cl. II, Div. 1, Groups E, F, G
 Cl. II, Div. 2, Groups F, G
 Cl. III
 NEMA 3, 4, 7CD, 9EFG, 12

Explosionproof
 Dust-Ignitionproof
 Raintight
 Wet Locations
 Watertight

2C

Applications:

- EPC magnetic line starters and enclosures are used:
- For across-the-line starting of polyphase AC induction motors
 - In locations made hazardous due to the presence of flammable vapors, gases or highly combustible dusts
 - In damp, wet or corrosive locations
 - Indoors or outdoors at petroleum refineries, chemical and petrochemical plants and other process industry facilities where similar hazards exist
 - To provide motor running protection, undervoltage protection, and remote starting and stopping

Features:

- Quick-opening covers – less than two turns to remove or install
- Three section design for ease of installation
- Water-shedding construction with female threads on top cover, male threads on bottom cover, and top cover skirted
- Specially located stops and locks ensure adequate thread engagement and prevent overtightening
- Separate replaceable mounting bracket attached to the rear of the body provides three-point suspension for quick installation and leveling – one keyhole slot at top and two open slots at bottom
- Bodies have two taper tapped conduit hubs with integral bushings on the top, and two more directly below
- Universal mounting plate and reset mechanism will accommodate any of the motor starters in catalog listing
- When interior mounting plate is removed, line and load conductors are easily pulled into the wiring chamber. The interior assembly with starter attached is then replaced, final connections made, and covers assembled
- Furnished with third overload relay as standard

Certifications and Compliances:

- NEC/CEC
 - Class I, Division 1 & 2, Groups C, D
 - Class II, Division 1, Groups E, F, G
 - Class II, Division 2, Groups F, G
 - Cl. III
- NEMA/EEMAC: 3, 4, 7CD, 9EFG, 12
- UL Standard: 1203
- CSA Standard: C22.2 No. 30

Standard Materials:

- Bodies and covers – copper-free aluminum
- Reset handle – copper-free aluminum
- Reset shaft – stainless steel
- Interior parts – stainless steel

Standard Finishes:

- Copper-free aluminum – natural
- Stainless steel – natural
- Sheet steel – electrogalvanized with chromate finish

Electrical Rating Range:

- Starter Sizes 0 to 1 inclusive

Options:

The following special options are available from factory by adding suffix to Cat. No. and many are available in kit form for field addition to existing units: See page 459 for listing of kits

Description

Control circuit transformer 600/480/240–120 volts, 50 or 60 hertz (Sizes 0 and 1 – 50VA, 100VA) Fusible – Secondary	FT
Primary and secondary	FTPS
Automatic reset overload relay	S1
Less overload relays (lighting contactor)	CL
Less overload relays (motor contactor)	CM
Auxiliary Contacts:*	
1NO/1NC	S781
2NO/2NC	S782
3NO/3NC	S783
Pilot light holes drilled, tapped and plugged for future addition of pilot lights –	
one hole	S541
two holes	S542
Side bosses drilled and tapped same size as standard hubs	S366
Back boss drilled and tapped same size as standard hubs	S367
Standard Breather (Cl. I, Groups C, D; Cl. II, Groups E, F, G; Cl. III)	S219
Standard Drain (Cl. I, Groups C, D; Cl. II, Groups E, F, G; Cl. III)	S198
Standard Breather and Drain (Cl. I, Groups C, D; Cl. II, Groups E, F, G; Cl. III)	S198V
Universal Breather-Drain (Cl. I, Groups C, D; Cl. II, Groups F, G)	S454‡
(2) Universal-Breather Drains (Cl. I, Groups C, D; Cl. II, Groups F, G)	S454V‡
Pushbuttons (heavy duty):	
START-STOP	PB3‡
Selector switches (standard duty):	
ON-OFF	RR2‡
HAND-OFF-AUTO.....	RR3‡
Pilot lights:	
Red, 120 volt	J1
Green, 120 volt	J3
Pilot light transformers:	
240 volt†	T2
480 volt†	T4
600 volt†	T5
Space heaters:	
120 volt	R11
240 volt	R22
480 volt	R44

*Application limited by starter or contactor design – consult factory.

†Required for pilot lights on other than 120 volt control circuits. One required for each lamp.

‡Not suitable for NEMA 4.



2C



CHS Controls AB
 Florettgatan 33
 SE-254 67 Helsingborg, Sweden
 Tel +46 42 38 61 00, Fax +46 42 38 61 29
 chs@chscontrols.se
 www.chscontrols.se

Ordering Information:

To order an enclosure complete with starter, insert the manufacturer's symbol in the designated position of the catalog number. Symbols are shown in the footnote at the bottom of this page. Specify HP, voltage, frequency, RPM, type and full load ampere rating of motor – or specify ampere rating of heaters.

Enclosures only can be ordered. Select from listings.

Motor Starter		Enclosure			Without Starter	With Starter	
Max. HP Polyphase	Volts	NEMA/EEMAC Size	Hub Size in.	Int. Dia. in.	Cat. #	Cat. # §	
2	120	0	1/4	7	EPC97	EPC970 ①613	
3	120	1	1/4	7	EPC97	EPC971 ①613	
3	240	0	1/4	7	EPC97	EPC970 ①623	
5	480	0	1/4	7	EPC97	EPC970 ①643	
5	600	0	1/4	7	EPC97	EPC970 ①653	
7 1/2	240	1	1/4	7	EPC97	EPC971 ①623	
10	480	1	1/4	7	EPC97	EPC971 ①643	
10	600	1	1/4	7	EPC97	EPC971 ①653	

① Motor Starters:

Manufacturer	Symbol
Allen-Bradley	AB
General Electric	G
Square D	D
Cutler-Hammer	W

Dimensions In Inches*:

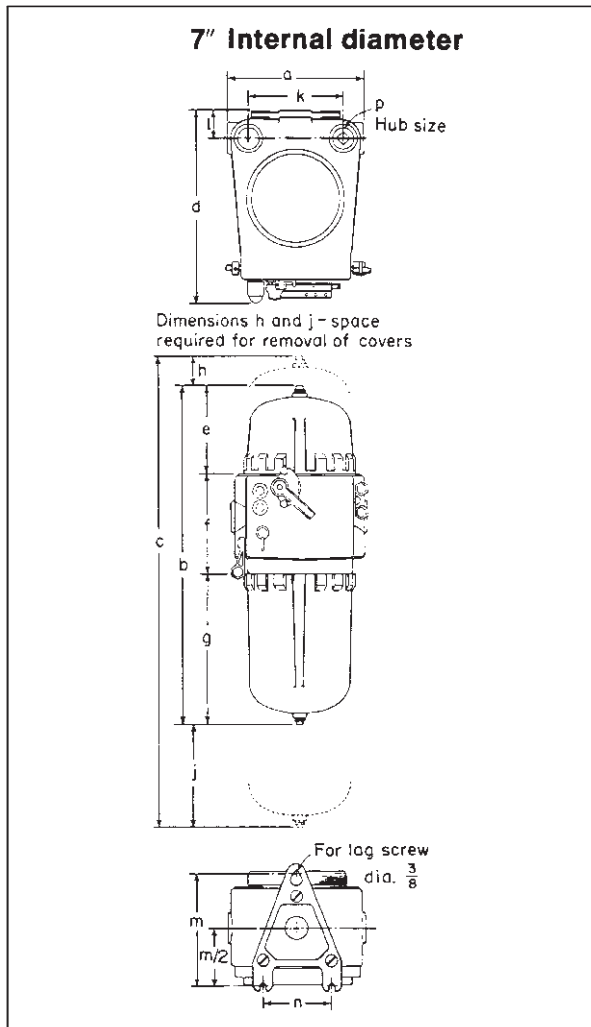

Single-Speed Non-Reversing Sizes 0, 1, Starters

Int. Dia.	EPC97	EPC97-FT EPC97-FTPS
	7"	7"
	Dimensions	Dimensions†
a	10 ⁵ / ₈	10 ⁵ / ₈
b	19 ¹³ / ₁₆	24 ¹³ / ₁₆
c	25 ¹³ / ₁₆	37 ¹³ / ₁₆
d	14 ¹¹ / ₁₆	14 ¹¹ / ₁₆
e	6 ³ / ₄	11 ³ / ₄
f	7 ¹¹ / ₁₆	7 ¹¹ / ₁₆
g	5 ³ / ₈	5 ³ / ₈
h	2	9
j	4	4
k	7 ³ / ₈	7 ³ / ₈
l	2 ¹ / ₁₆	2 ¹ / ₁₆
m	9 ³ / ₈	9 ³ / ₈
n	5 ¹ / ₄	5 ¹ / ₄
p	1 ¹ / ₄	1 ¹ / ₄



CHS Controls AB
 Florettgatan 33
 SE-254 67 Helsingborg, Sweden
 Tel +46 42 38 61 00, Fax +46 42 38 61 29
 chs@chscontrols.se
 www.chscontrols.se

*Dimensions are approximate, not for construction.
 †For units with Control Circuit Transformer (suffix FT or FTSP).
 § Starters are furnished with three heaters when heater ratings are fully specified.

Special Feature Kits

Pushbutton Station and Selector Switch Kits

EPC magnetic line starter and EPC combination line starter enclosures are provided as standard with switch operating shaft holes drilled, tapped and plugged. Pushbutton stations and selector switches can be assembled in these enclosures in the field, using kits listed below.

Applies to 7" and 11" EPC

Description	Cat. #
START-STOP pushbutton station assembly	EPC PB3 KIT
Replacement pushbutton station only for EPC-PB3-KIT	16320 N
ON-OFF selector switch assembly (2 position)	EPC RR2 KIT
Replacement switch only for EPC-RR2-KIT	ESWP126
HAND-OFF-AUTO selector switch assembly (3 position)	EPC RR3 KIT
Replacement switch only for EPC-RR3-KIT	ESWP126

Pilot Light Kits

When EPC magnetic line starter and EPC combination line starter enclosures have been ordered with pilot light holes drilled, tapped and plugged (Cat. No. suffix S541 and S542), pilot lights can be assembled in the field, using kits listed below.

Description	Applies to	Cat. #
Pilot light assembly less transformer	7", 11" EPC	EMP015 ① KIT
Pilot light assemblies with transformer and transformer mounting strap (for single pilot light) suffix S541	7" EPC only	EPC87 ① ② KIT
	11" EPC only	EPC813 ① ② KIT
2 pilot light assemblies with 2 transformers and transformer mounting strap (for double pilot light) suffix S542	7" EPC only	EPC87 ① ① ② KIT
	11" EPC only	EPC813 ① ① ② KIT
Replacement pilot light transformer only (240V primary)	All units	15129 A
Replacement pilot light transformer only (480V primary)	All units	15130 A
Replacement pilot light transformer only (600V primary)	All units	15131 A

①Insert color symbol from table below and

②add primary voltage symbol

Example: EPC87-①-①-②-KIT with red and green pilot lights for 480 volts is EPC-J1-J3-T4-KIT.

Color	Symbol	Color	Symbol
Red	J1	Clear	J10
Green	J3	Blue	J11
Amber	J6		

Voltage	Symbol
240	T2
480	T4
600	T5



CHS Controls AB
 Florettgatan 33
 SE-254 67 Helsingborg, Sweden
 Tel +46 42 38 61 00, Fax +46 42 38 61 29
 chs@chscontrols.se
 www.chscontrols.se

EMN Series Manual Line Starters and Enclosures

600VAC Maximum

Cl. I, Div. 1 & 2, Groups C, D Explosionproof
 Cl. II, Div. 1, Groups E, F, G Dust-Ignitionproof
 Cl. II, Div. 2, Groups F, G Raintight
 Cl. III Wet Locations
 NEMA 3, 7CD, 9EFG, 12



CHS Controls AB

Tel +46 42 38 61 00, Fax +46 42 38 61 29
 chs@chscontrols.se www.chscontrols.se

Applications:

EMN manual line starters and enclosures are used:

- For manual across-the-line starting of single and polyphase AC motors
- To provide motor running protection and manual starting and stopping
- In locations made hazardous due to the presence of flammable vapors, gases, or high combustible dusts
- For installation in petroleum refineries, chemical and petrochemical plants, and other process industry facilities
- In damp, wet, or corrosive locations

Features:

- Compact, rectangular enclosure makes optimum use of internal space
- Operating handle may be padlocked in either "ON" or "OFF" position
- Compact design allows installation in area where space is limited
- Furnished with drilled and tapped conduit openings
- Polyphase manual starters are furnished with third overload relay as standard

Certifications and Compliances:

- NEC/CEC
 - Class I, Division 1 & 2, Groups C, D
 - Class II, Division 1, Groups E, F, G
 - Class II, Division 2, Groups F, G
 - Class III
- NEMA/EEMAC: 3, 7CD, 9EFG, 12
- UL Standard: 1203
- CSA Standard: C22.2 No. 14

Standard Materials:

- Bodies, covers and toggle operator – copper-free aluminum
- Operating shaft – stainless steel
- Internal operating bail – sheet steel or aluminum

Standard Finishes:

- Copper-free aluminum – natural
- Stainless steel – natural
- Sheet steel – electrogalvanized with chromate finish

Electrical Rating Ranges:

- Starter sizes 0, 1, 1P

Options:

The following special options are available from factory by adding suffix to Cat. #:

Description	Suffix
Standard Breather (Cl. I, Groups C, D; Cl. II, Groups E, F, G; Cl. III)	S219
Standard Drain (Cl. I, Groups C, D; Cl. II, Groups E, F, G; Cl. III)	S198
Standard Breather and Drain (Cl. I, Groups C, D; Cl. II, Groups E, F, G; Cl. III)	S198V
Universal Breather-Drain (Cl. I, Groups C, D; Cl. II, Groups F, G)	S454
(2) Universal Breather-Drains (Cl. I, Groups C, D; Cl. II, Groups F, G)	S454V

Ordering Information:

Specify HP, voltage, frequency, number of phases, RPM, type and full load ampere rating of motor – or specify ampere rating of heaters.

Two pole starters require one heater; three pole starters have three heaters.



Motor Starter

NEMA Size	Poles (Phase)	Max. AC HP Ratings			Enclosure With Starter Cat. #
		115V	208/240V	480/600V	
M-0	2 (1PH)	1	2		EMN24 W20
M-1	2 (1PH)	2	3		EMN24 W21
M-1P	2 (1PH)	3	5		EMN24 W21P
M-0	3 (3PH)	2	3	5	EMN24 W30
M-1	3 (1PH)	2	3		EMN24 W30
M-1	3 (3PH)	3	7½	10	EMN24 W31

Enclosure Without Starter

Starter Manufacturer	Enclosure Cat. #†
Cutler-Hammer	EMN24

Dimensions*

In Inches:

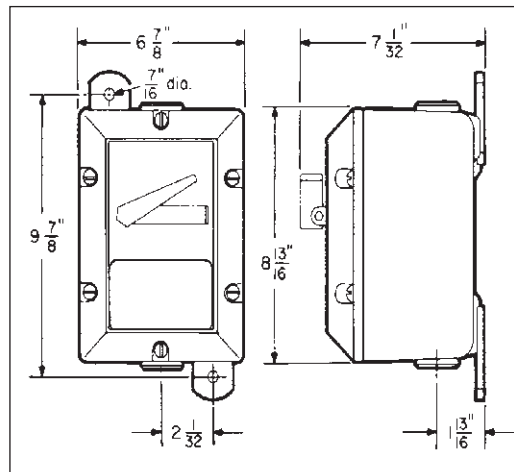

†Enclosures are furnished with two 1/4" drilled and tapped openings with 1/2" to 1" reducers.
 *Dimensions are approximate, not for construction purposes.

EFD Series Manual Motor Starting Switches and Enclosures

Cl. I, Div. 1 & 2, Groups B*, C, D Explosionproof
 Cl. II, Div. 1, Groups E, F, G Dust-Ignitionproof
 Cl. II, Div. 2, Groups F, G Raintight
 Cl. III Wet Locations
 NEMA 3, 7B*CD, 9EFG, 12

2C

Applications:

EFD manual motor starting and stopping switch enclosures are used:

- For manual starting of small AC or DC motors
- In locations made hazardous due to the presence of flammable vapors, gases or highly combustible dusts
- For installation at petroleum refineries, chemical and petrochemical plants and in other process industry facilities where similar hazards exist

Features:

- Enclosure is small and compact
- Accurately ground flange on both body and cover for flame-tight joint
- Switch can be padlocked in either "ON" or "OFF" positions
- Dead end (EFD) or through feed (EFDC) hubs in 3/4" to 1" size

Certifications and Complies:

- NEC/CEC
 Class I, Division 1 & 2, Groups B*, C, D
 Class II, Division 1, Groups E, F, G
 Class II, Division 2, Groups F, G
 Class III
- NEMA: 3, 7B*CD, 9EFG, 12
- UL Standard: 1203
- CSA Standard: C22.2 No. 30

Standard Materials:

- Bodies and covers - *Feraloy*® iron alloy
- Operating handle - type 6 / 6 nylon
- Operating shaft - stainless steel

Standard Finishes:

- *Feraloy* iron alloy - electrogalvanized and aluminum acrylic paint
- Type 6 / 6 nylon - natural (black)
- Stainless steel - natural

Options:

The following special options are available from factory by adding suffix to Cat. #:

Description	Suffix
For use in Group B hazardous areas	GB*



EFD dead end

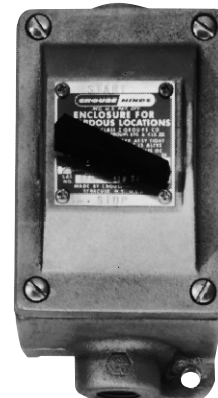

EFDC through feed

Electrical Ratings Without Overload Protection With Switches

Poles	Cat. #	Switch Ratings Amps			HP		
2	Square D Class 2510 Type KO-1	250VAC	600VAC	115VAC	230VAC	460-575VAC	
		30	20	1	2	3	
3	GE TC2368S	30A., 240VAC, 7-1 / 2 hp			20A., 600VAC, 15 hp		

Ordering Information

Dead end			
Poles	Hub Size in.	With Switch	Cat. #
2	3/4 1	EFD218 T8	
		EFD318 T8	
3	3/4 1	EFD2419	
		EFD3419	

Through feed			
Poles	Hub Size in.	With Switch	Cat. #
2	3/4 1	EFDC218 T8	
		EFDC318 T8	
3	3/4 1	EFDC2419	
		EFDC3419	

Dimensions In Inches:

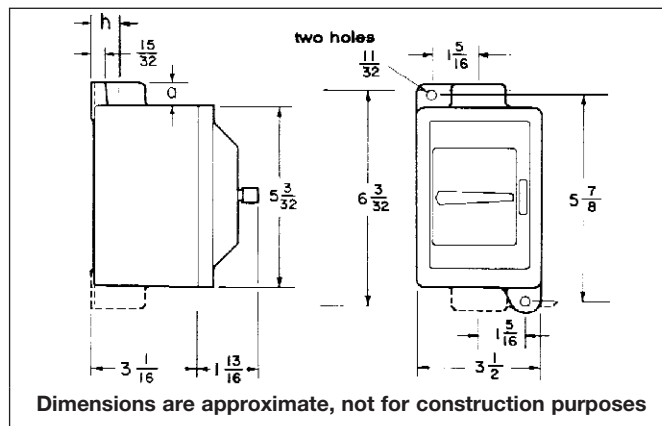

Hub Size	Dim. "h"	Dim. "a"
3/4	7/8	13/16
1	1	15/16

*Add GB suffix. Seals must be installed within 1 1/2" of each conduit opening for Group B usage.



CHS Controls AB
 Tel +46 42 38 61 00, Fax +46 42 38 61 29
chs@chscontrols.se www.chscontrols.se

EDS Series Factory Sealed Manual Motor Starting Switches and Enclosures

Cl. I, Div. 1 & 2, Groups B*, C, D Explosionproof
 Cl. II, Div. 1, Groups E, F, G Dust-Ignitionproof
 Cl. II, Div. 2, Groups F, G Raintight
 Cl. III Wet Locations
 NEMA 3, 7B*CD, 9EFG

Applications:

Factory sealed enclosures are installed in a rigid metallic conduit system for surface mounting adjacent to or remote from equipment being controlled and are used:

- To prevent arcing of enclosed device from causing ignition of a specific hazardous atmosphere or atmospheres external to the enclosure
 - In industrial areas such as chemical plants, oil and gas refineries, paint and varnish manufacturing plants, gasoline bulk loading terminals, grain elevators, grain processing industries, coal processing or handling areas, or metal handling or finishing areas where atmosphere may contain hazardous gases and/or dust
 - In non-hazardous areas where sturdy, durable enclosures are required
 - In conjunction with magnetic starters or contactors for remote control of motors
- Manual motor starting switch enclosures are used:
- For manual starting of small AC or DC motors
 - To provide manual starting and stopping and, in the case of units with heaters, motor running protection

Features:

Factory sealed devices have many distinct advantages:

- Reduce installation problems
- Eliminate external seals
- Lower installation costs
- Improve safety
- Mounting lugs and taper tapped hubs with integral bushings
- Large machine screws for fastening covers to bodies
- Lockout hole for padlock having 1/4" hasp is provided
- Close tolerances in machining of wide, mating flanges and journalled shafts and bearings produce flametightness of enclosure joints
- Dead end (EDS) or through feed (EDSC) hubs - 3/4" or 1" sizes

Certifications and Compliances:

- NEC/CEC
 - Class I, Division 1 & 2, Groups B*, C, D
 - Class II, Division 1, Groups E, F, G
 - Class II, Division 2, Groups F, G
 - Class III
- NEMA/EEMAC: 3, 7B*CD, 9EFG
- UL Standard: 1203
- CSA Standard: C22.2 No. 30



EDSC2199

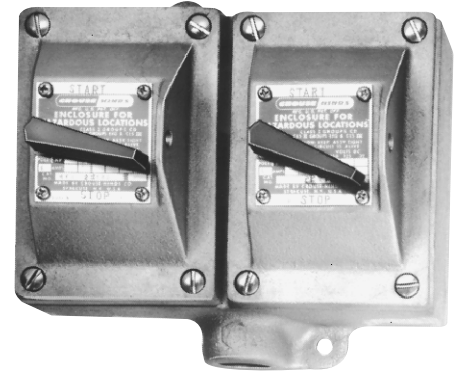

EDS2299

Standard Materials:

- Bodies - *Feraloy*® iron alloy (U.S.); copper-free aluminum (Canada)
- Shafts & bushings - stainless steel
- Sealing enclosures - copper-free aluminum

Standard Finishes:

- Feraloy* iron alloy - electrogalvanized and aluminum acrylic paint
- Copper-free aluminum - natural
 - Type 6 / 6 nylon - black
 - Stainless steel - natural

Dimensions In Inches:

Side View

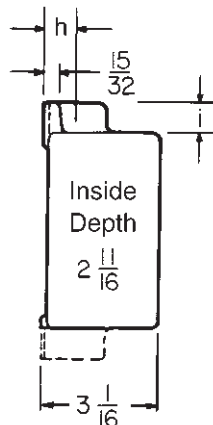

Options:

Description	Suffix
For use in Group B hazardous areas	GB*
Bodies and covers (single and two gang units) - copper-free aluminum	SA

Hub Size	Dim. "h"	Dim. "i"
3/4	13/16	
1	1 5/16	

Front View

Single gang

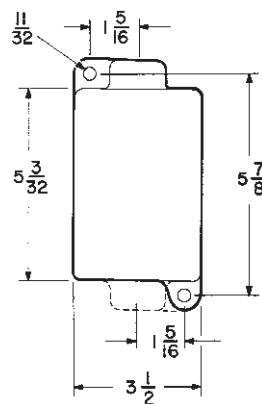

Two gang

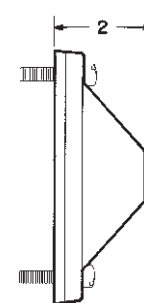
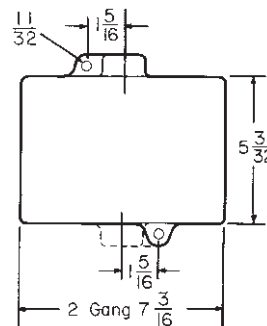

Surface covers have same length and width as single & 2 gang bodies.

Dimensions are approximate, not for construction purposes.

*Seals must be installed within 1/2" of each conduit opening in Division 1.

CHS Controls AB
 Tel +46 42 38 61 00, Fax +46 42 38 61 29
 chs@chscontrols.se www.chscontrols.se

EDS Series Factory Sealed Manual Motor Starting Switches and Enclosures

Cl. I, Div. 1 & 2, Groups B*, C, D Explosionproof
 Cl. II, Div. 1, Groups E, F, G Dust-Ignitionproof
 Cl. II, Div. 2, Groups F, G Raintight
 Cl. III Wet Locations
 NEMA 3, 7B*CD, 9EFG

2C

Ordering Information

With Allen-Bradley Bulletin 600 Switches

Maximum HP Ratings				
Poles	115-230 Volts AC	115-230 Volts DC	Cat. #	
1	1 hp		A B BUL 600 TOX4	
2	1 hp	¾ hp	A B BUL 600 TOX5	
Poles	Hub Size in.	Dead end Cat. #	Through feed Cat. #	
Single Gang				
1	¾	EDS2199 ①	EDSC2199 ①	
	1	EDS3199 ①	EDSC3199 ①	
2	¾	EDS21100 ①	EDSC21100 ①	
	1	EDS31100 ①	EDSC31100 ①	
Two Gang				
1	¾	EDS2299 ①	EDSC2299 ①	
	1	EDS3299 ①	EDSC3299 ①	
2	¾	EDS22100 ①	EDSC22100 ①	
	1	EDS32100 ①	EDSC32100 ①	

With General Electric Switches

Maximum HP Ratings				
Poles	115-230 Volts AC	115 Volts DC	230 Volts DC	Cat. #
1	1 hp	1 hp	¼ hp	GE CR101 Y
2	1 hp	1 hp	1 hp	GE CR101 H
Poles	Hub Size in.	Dead end Cat. #	Through feed Cat. #	
Single Gang				
1	¾	EDS21093 ①	EDSC21093 ①	
	1	EDS31093 ①	EDSC31093 ①	
2	¾	EDS21094 ①	EDSC21094 ①	
	1	EDS31094 ①	EDSC31094 ①	
Two Gang				
1	¾	EDS22093 ①	EDSC22093 ①	
	1	EDS32093 ①	EDSC32093 ①	
2	¾	EDS22094 ①	EDSC22094 ①	
	1	EDS32094 ①	EDSC32094 ①	

Heater Table (Allen-Bradley)

Max. Motor Full-Load Amps	Crouse-Hinds Symbol Number	Max. Motor Full-Load Amps	Crouse-Hinds Symbol Number
0.17	P1	2.92	P22
0.21	P2	3.09	P23
0.25	P3	3.32	P24
0.32	P4	3.77	P25
0.39	P5	4.16	P26
0.46	P6	4.51	P27
0.57	P7	4.93	P28
0.71	P8	5.43	P29
0.79	P9	6.03	P30
0.87	P10	6.83	P31
0.98	P11	7.72	P32
1.08	P12	8.24	P33
1.19	P13	8.9	P34
1.30	P14	9.6	P35
1.43	P15	10.8	P36
1.58	P16	12.0	P37
1.75	P17	13.5	P38
1.88	P18	15.2	P39
2.13	P19		
2.40	P20		
2.58	P21		

Heater Table (General Electric)

Max. Motor Full-Load Amps	Crouse-Hinds Symbol Number	Max. Motor Full-Load Amps	Crouse-Hinds Symbol Number
.48	G2	3.01	G22
.53	G3	3.27	G23
.58	G4	3.56	G24
.65	G5	3.88	G25
.71	G6	4.22	G26
.78	G7	4.60	G27
.86	G8	5.00	G28
.95	G9	5.43	G29
1.04	G10	5.90	G30
1.14	G11	6.41	G31
1.25	G12	6.98	G32
1.37	G13	7.60	G33
1.49	G14	8.25	G34
1.63	G15	8.95	G35
1.78	G16	9.75	G36
1.95	G17	10.6	G37
2.13	G18	11.4	G38
2.32	G19	12.5	G39
2.53	G20	13.6	G40
2.76	G21	14.8	G41
		16.0	G42

① Includes one interchangeable heater. Select heater from the table below individual listings and use symbol number as second section of the Cat. No. Example: EDS2199-P5. Insert symbol 0 (zero) to omit heater.

These heaters are for motors rated 40°C continuously. For motors rated 50°C or 55°C, multiply full load motor current by 0.9 and use this value to select heaters. Symbol 0 (zero) must be used to indicate heater omitted.

*Add GB suffix. Seals must be installed within 1/2" of each conduit opening for Group B usage.



CHS Controls AB
 Florettgatan 33
 SE-254 67 Helsingborg, Sweden
 Tel +46 42 38 61 00, Fax +46 42 38 61 29
 chs@chscontrols.se
 www.chscontrols.se

EDS Series Factory Sealed Manual Motor Starting Switches and Enclosures

Cl. I, Div. 1 & 2, Groups B*, C, D
 Cl. II, Div. 1, Groups E, F, G
 Cl. II, Div. 2, Groups F, G
 Cl. III
 NEMA 3, 7B*CD, 9EFG

Explosionproof
 Dust-Ignitionproof
 Raintight
 Wet Locations

With Cutler-Hammer Switches

Maximum HP Ratings

Poles	120-240		32	120	240	Cat. #
	Volts AC	Volts DC	Volts DC	Volts DC	Volts DC	
1	1 hp	¼ hp	¼ hp	¼ hp	¼ hp	WEST MST01
2	1 hp	¼ hp	¼ hp	1 hp	¾ hp	WEST MST02

Poles	Hub Size in.	Dead end Cat. #	Through feed Cat. #
Single Gang			
1	¾	EDS21101 ①	EDSC21101 ①
	1	EDS31101 ①	EDSC31101 ①
2	¾	EDS21102 ①	EDSC21102 ①
	1	EDS31102 ①	EDSC31102 ①
Two Gang			
1	¾	EDS22101 ①	EDSC22101 ①
	1	EDS32101 ①	EDSC32101 ①
2	¾	EDS22102 ①	EDSC22102 ①
	1	EDS32102 ①	EDSC32102 ①

Heater Table (Cutler-Hammer)

Max. Motor Full-Load Amps	Crouse-Hinds Symbol Number	Max. Motor Full-Load Amps	Crouse-Hinds Symbol Number
.43	W 1	2.95	W21
.48	W 2	3.27	W22
.53	W 3	3.59	W23
.58	W 4	3.99	W24
.64	W 5	4.39	W25
.71	W 6	4.79	W26
.78	W 7	5.26	W27
.87	W 8	5.83	W28
.95	W 9	6.39	W29
1.03	W10	7.03	W30
1.15	W11	7.74	W31
1.27	W12	8.46	W32
1.35	W13	9.35	W33
1.51	W14	10.30	W34
1.67	W15	11.35	W35
1.83	W16	12.47	W36
1.99	W17	13.67	W37
2.23	W18	15.12	W38
2.47	W19	16.00	W39
2.71	W20		

① Includes one interchangeable heater. Select heater from the table below individual listings and use symbol number as second section of the Cat. No. Example: EDS2199-P5. Insert symbol 0 (zero) to omit heater.

These heaters are for motors rated 40°C continuously. For motors rated 50°C or 55°C, multiply full load motor current by 0.9 and use this value to select heaters. Symbol 0 (zero) must be used to indicate heater omitted.

*Add GB suffix. Seals must be installed within 1½" of each conduit opening for Group B usage.



CHS Controls AB

Florettgatan 33
 SE-254 67 Helsingborg, Sweden
 Tel +46 42 38 61 00, Fax +46 42 38 61 29
 chs@chscontrols.se
 www.chscontrols.se

GHG 635 Series Explosion Protected Manual Motor Starters 25 Amp, 690 VAC Non-metallic Enclosure

UL/cUL Listed
Cl. I, Div. 2, Groups A, B, C, D
Cl. I, Zones 1 and 2, AEx de
IIB + H₂, T5, T6
Cl. II, Div. 1, Groups E, F, G (cUL)

CENELEC - PTB 99
ATEX 1162 Certified
Ex de IIC, T6, Zones 1 and 2
Ex de IIC, T6 Zones 21 and 22
IP66, NEMA 4X

2C

Applications:

- Explosion protected manual motor starters are used in a metallic conduit or cable system for surface mounting to protect motors against overload and phase failure.

Features:

- Explosion protected factory sealed circuit breaker and manual motor starter
- Innovative break-line in cover allows full wiring access, making installation quick and easy
- Switch handle provides clear indication of switch position
- Lockable handle meets OSHA lockout/tagout requirements, provision for 3 padlocks
- Large rotary handle provides easy gripping with gloved hands
- Captive cover screws

Certifications and Complies:

- UL/cUL Listed
- Class I, Division 2, Groups A, B, C, D
- Class I, Zones 1 and 2, Ex de IIB+H₂, T6
- Class II, Division 1, Groups E, F, G (cUL)
- CENELEC - PTB 99-ATEX 1162
- Ex de IIC, T6, Zones 1 and 2
- IP66, NEMA 4X

Standard Materials:

- Enclosure - Fiberglass-reinforced polyester
Nonmetallic, corrosion resistant
Increased safety Ex-e protection
Impact Resistant
NEMA 4X, IP66 Protection
Enclosure meets UL 94-VO
UV rated
- Enclosure Gasket - Silicon
- Handle - Impact-resistant thermoplastic
- Cover Screws - Stainless steel
- Conduit Entries - Zinc Myers Hubs
- Brass Mounting plate - Ground continuity



Technical Data

Type of Protection

Rated Voltage

Rated Current

Rated Current, Aux. Contact

Short Circuit

Under Voltage Trip

Connection Terminals

Connection Terminals, Aux. Contact

Conduit or Cable Entries

Weight

(A)Ex ed IIC T5, T6

Up to 690 VAC

Up to 25 A

2 A

See table on next page

Tripping at 15% – 75% V-rated
Switching - on when V> 80% V-rated

Up to 10mm²

2 x 2.5 mm²

2 x 3/4" Myers hubs

5.5 lbs./2.5 Kg.

2C



CHS Controls AB
 Florettgatan 33
 SE-254 67 Helsingborg, Sweden
 Tel +46 42 38 61 00, Fax +46 42 38 61 29
 chs@chscontrols.se
 www.chscontrols.se

2C GHG 635 Series Explosion Protected Manual Motor Starters 25 Amp, 690 VAC Non-metallic Enclosure

UL/cUL Listed
Cl. I, Div. 2, Groups A, B, C, D
Cl. I, Zones 1 and 2, AEx de
IIB + H₂, T5, T6
Cl. II, Div. 1, Groups E, F, G (cUL)

CENELEC - PTB 99
ATEX 1162 Certified
Ex de IIC, T6, Zones 1 and 2
Ex de IIC, T6 Zones 21 and 22
IP66, NEMA 4X

Short Circuit Protection

Setting Range	400 VAC AIC	500 VAC AIC	690 VAC AIC
0.1 A – 1.6 A	N/A*	N/A*	N/A*
1.6 A – 2.5 A	N/A*	N/A*	40
2.5 A – 4.0 A	N/A*	60	10
4.0 A – 6.3 A	N/A*	40	7
6.3 A – 9.0 A	N/A*	30	5
9.0 A – 12.5 A	75	27	4.5
12.5 A – 16.0 A	60	25	4
16.0 A – 20.0 A	55	22	3.5
20.0 A – 25.0 A	50	20	3

* Short-circuit proof. No back-up fuse required.

Ordering Information

Setting Range or rated current	Cat. #
0.1 – 0.16 A	GHG 635 1101 L0101
0.16 – 0.25 A	GHG 635 1101 L0102
0.25 – 0.40 A	GHG 635 1101 L0103
0.40 – 0.63 A	GHG 635 1101 L0104
0.63 – 1.0 A	GHG 635 1101 L0105
1.0 – 1.6 A	GHG 635 1101 L0106
1.6 – 2.5 A	GHG 635 1101 L0107
2.5 – 4.0 A	GHG 635 1101 L0108
4.0 – 6.3 A	GHG 635 1101 L0109
6.3 – 9.0 A	GHG 635 1101 L0110
9.0 – 12.5 A	GHG 635 1101 L0111
12.5 – 16 A	GHG 635 1101 L0112
16 – 20 A	GHG 635 1101 L0113
20 – 25 A	GHG 635 1101 L0114

Accessory Options†

- 1 = without aux. contact
- 2 = with aux. contact 1 NO + 1NC
- 3 = with aux. contact 2 NO

†Catalog numbers on this page are shown without auxiliary contacts. To add aux. contacts, change last number in "1101" to a 2 or 3. Ex. 1102.

Wiring Diagram

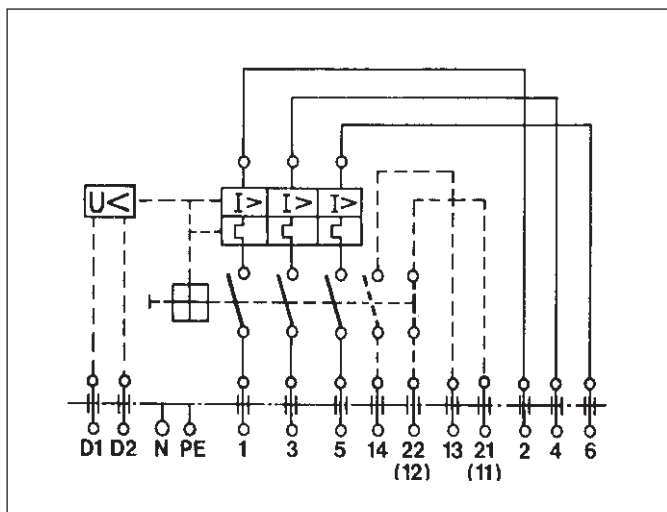

Dimensions In Inches:

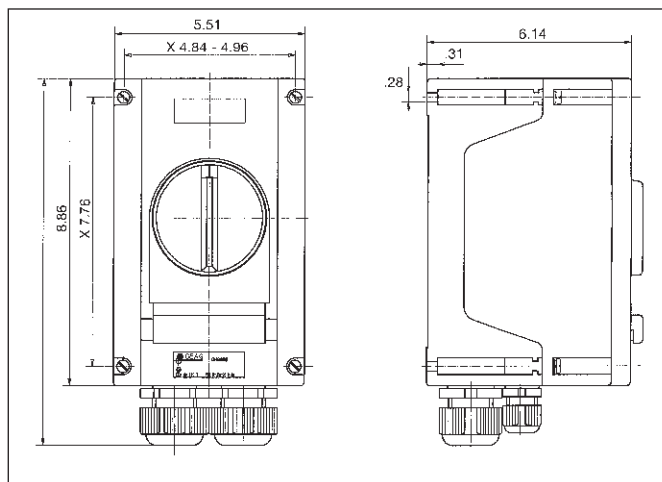

CHS Controls AB

Florettgatan 33
SE-254 67 Helsingborg, Sweden
Tel +46 42 38 61 00, Fax +46 42 38 61 29
chs@chscontrols.se
www.chscontrols.se

Applications:

MC manual motor starting switches and enclosures are used:

- For manual starting of small AC and DC motors of one horsepower or less (see next page for ratings)
- In damp, wet or corrosive locations such as dairies, meat packing plants, chemical plants and outdoor locations
- To provide motor running protection and manual starting and stopping

Features:

- Enclosure is compact and gasketed to meet NEMA/EEMAC 4 requirements for watertightness
- Switch can be padlocked in either the "ON" or "OFF" positions
- Provided with dead end (MC) or throughfeed (MCC) hubs – 1/2" and 3/4" sizes – with mounting feet

Certifications and Complies:

- NEMA/EEMAC: 3, 4, 12
- UL Standard: 508
- CSA Standard: C22.2 No. 14

Standard Materials:

- Body and cover – *Feraloy*® iron alloy
- Operating handle – copper-free aluminum
- Operating shaft – stainless steel

Standard Finishes:

- *Feraloy* – electrogalvanized and aluminum acrylic paint
- Copper-free aluminum – natural
- Stainless steel – natural



MC dead end



MCC through feed

Dimensions In Inches*:

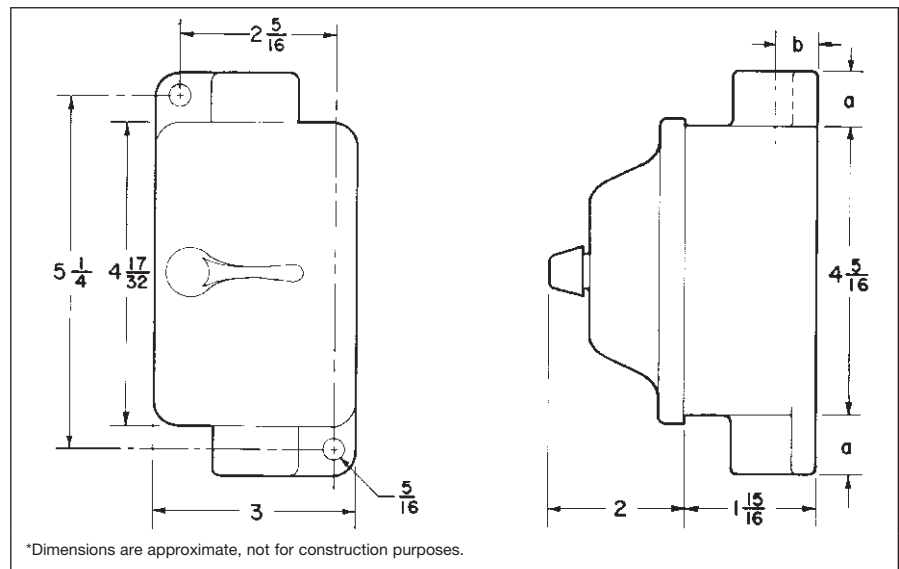

Hub Size	1/2	3/4
a	7/8	7/8
b	5/8	3/4



CHS Controls AB

Florettgatan 33
SE-254 67 Helsingborg, Sweden
Tel +46 42 38 61 00, Fax +46 42 38 61 29
chs@chscontrols.se
www.chscontrols.se

MC Manual Motor Starting Switches

Manufacturer	Poles	Cat. #
Cutler-Hammer	1	MST01
Cutler-Hammer	2	MST02

Maximum Horsepower Ratings

Volts	1-Pole	2-Pole
120 / 240 AC	1	1
32 DC	1/4	1/4
120 / 240 DC		1
240 DC	1/4	

Ordering Information - MC Single Gang (Dead End)

Poles	Hub Size in.	Enclosure With Switch Cat. #	Without Switch Cat. #
1	1/2	MC1211 ①	MC1212B
1	3/4	MC2211 ①	MC2212B
2	1/2	MC1212 ①	MC1212B
2	3/4	MC2212 ①	MC2212B

Ordering Information - MCC Single Gang (Through Feed)

Poles	Hub Size in.	Enclosure With Switch Cat. #	Without Switch Cat. #
1	1/2	MCC1211 ①	MCC1212B
1	3/4	MCC2211 ①	MCC2212B
2	1/2	MCC1212 ①	MCC1212B
2	3/4	MCC2212 ①	MCC2212B

Heater Table

Full Load Motor Current	Heater Rating	Cooper Crouse-Hinds Symbol Number
.40 - .43	.50	W1
.44 - .48	.55	W2
.49 - .53	.61	W3
.54 - .58	.67	W4
.59 - .64	.74	W5
.65 - .71	.81	W6
.72 - .78	.89	W7
.79 - .87	.98	W8
.88 - .95	1.10	W9
.96 - 1.03	1.20	W10
1.04 - 1.15	1.30	W11
1.16 - 1.27	1.45	W12
1.28 - 1.35	1.60	W13
1.36 - 1.51	1.70	W14
1.52 - 1.67	1.90	W15
1.68 - 1.83	2.10	W16
1.84 - 1.99	2.30	W17
2.00 - 2.23	2.50	W18
2.24 - 2.47	2.80	W19
2.48 - 2.71	3.10	W20
2.72 - 2.95	3.40	W21
2.96 - 3.27	3.70	W22
3.28 - 3.59	4.10	W23
3.60 - 3.99	4.50	W24
4.00 - 4.39	5.00	W25
4.40 - 4.79	5.50	W26
4.80 - 5.26	6.00	W27
5.27 - 5.83	6.60	W28
5.84 - 6.39	7.30	W29
6.40 - 7.03	8.00	W30
7.04 - 7.74	8.80	W31
7.75 - 8.46	9.70	W32
8.47 - 9.35	10.60	W33
9.36 - 10.30	11.70	W34
10.31 - 11.35	12.90	W35
11.36 - 12.47	14.20	W36
12.48 - 13.67	15.60	W37
13.68 - 15.12	17.10	W38
15.13 - 16.00	18.60	W39



CHS Controls AB

Florettgatan 33
 SE-254 67 Helsingborg, Sweden
 Tel +46 42 38 61 00, Fax +46 42 38 61 29
 chs@chscontrols.se
 www.chscontrols.se

① Includes one interchangeable heater. Select heater from table above and use symbol number as second section of the Cat. No. Example: MC1211-W5. Symbol 0 (zero) may be used to indicate heater omitted.

These heaters are for motors rated 40°C continuously. For motors rated 50°C or 55°C, multiply full load motor current by 0.9 and use this value to select heaters.

NSSC Series Manual Motor Starting Switches and NFS Series Fractional HP Starters and Enclosures

Corrosion-Resistant
Dust-tight
Watertight
Weatherproof
NEMA 3, 4X, 12

2C

Applications:

- Motor Starting Switches are used in manual "ON" and "OFF" control of DC and single-phase or three-phase AC motors where overload protection is not required or is provided separately
- NFS Series Fractional Horsepower Starters are used in manual "ON" and "OFF" control and overload protection of small single phase motors
- Both are suitable for use in wet and/or corrosive environments

Features:

- Enclosures are made of Cooper Crouse-Hinds high-impact strength *Krydon*® fiberglass-reinforced polyester material which has excellent corrosion resistance and stability to heat
- Provided with a toggle lever with a molded-in stainless steel shaft
- Factory installed through feed (NSSC, NFS) hubs, 1/2" or 3/4" size
- Indicating plate is made of stainless steel

Certifications and Compliances:

- NEMA 3, 4X, and 12

Options:

- Grounding plate or bushing – see page 646



Ordering Information

NSSC Series Manual Motor Starting Switch Without Overload Protection With Square D Switches

Poles	Max. HP Rating			Max. Amp. Ratings	
	115 VAC	200–230 VAC	460–575 VAC	250 VDC	600 VDC
2	1	2	3	30	20
3	2	7½	10	30	20

Poles	Enclosure With Switch	
	Hub Size	Through Feed Cat. #
2	1/2	NSSC D12
	3/4	NSSC D22
3	1/2	NSSC D13
	3/4	NSSC D23

Enclosures Only

Enclosure Type	Hub Size	Through Feed Cat. #
Manual Motor Starting Switch	1/2	NSSC1
	3/4	NSSC2
Fractional HP Starter	1/2	NFSC1
	3/4	NFSC2

Dimensions*

In Inches:

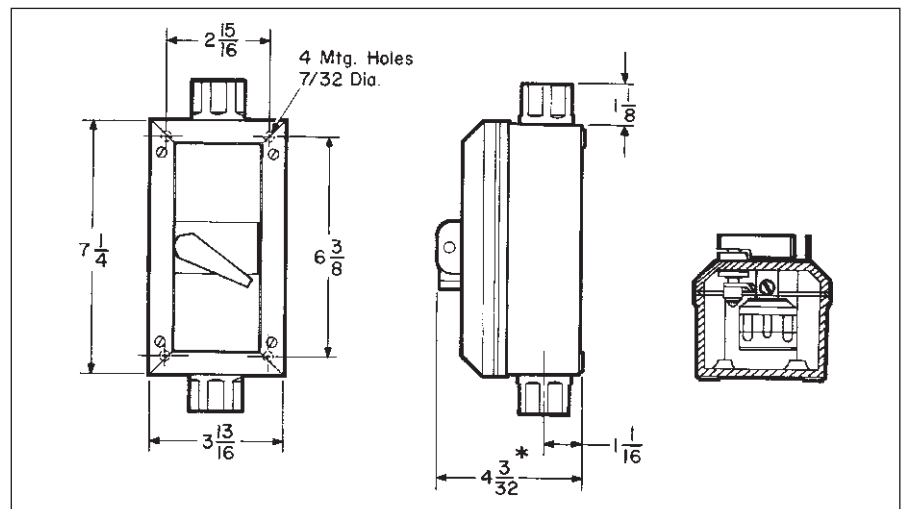

*Dimensions are approximate. Not to be used for construction purposes unless approved.



CHS Controls AB

Florettgatan 33
SE-254 67 Helsingborg, Sweden
Tel +46 42 38 61 00, Fax +46 42 38 61 29
chs@chscontrols.se
www.chscontrols.se

Ordering Information

NFSC Series Fractional HP Starters With Overload Protection

With Allen-Bradley Bulletin 600 Switches

Poles	Maximum HP Ratings	
	115-230 Volts AC	115-230 Volts DC
1	1 hp	
2	1 hp	3/4 hp

Poles	Enclosure With Starter	
	Hub Size	Through Feed Cat. #
1	1/2	NFSC AB11 ①
	3/4	NFSC AB21 ①
2	1/2	NFSC AB12 ①
	3/4	NFSC AB22 ①

Heater Table (see page 463)

With Cutler-Hammer Switches

Poles	Maximum HP Ratings	
	115-230 Volts AC	115-230 Volts DC
1	1 hp	
2	1 hp	1 hp

Poles	Enclosure With Starter	
	Hub Size	Through Feed Cat. #
1	1/2	NFSC C11 ①
	3/4	NFSC C21 ①
2	1/2	NFSC C12 ①
	3/4	NFSC C22 ①

Heater Table (Cutler-Hammer)

Max. Motor Full-Load Amps	Crouse-Hinds Symbol Number	Max. Motor Full-Load Amps	Crouse-Hinds Symbol Number
.43	W 1	2.95	W21
.48	W 2	3.27	W22
.53	W 3	3.59	W23
.58	W 4	3.99	W24
.64	W 5	4.39	W25
.71	W 6	4.79	W26
.78	W 7	5.26	W27
.87	W 8	5.83	W28
.95	W 9	6.39	W29
1.03	W10	7.03	W30
1.15	W11	7.74	W31
1.27	W12	8.46	W32
1.35	W13	9.35	W33
1.51	W14	10.30	W34
1.67	W15	11.35	W35
1.83	W16	12.47	W36
1.99	W17	13.67	W37
2.23	W18	15.12	W38
2.47	W19	16.00	W39
2.71	W20		

With General Electric Switches

Poles	Maximum HP Ratings			
	115-230 VAC	32 VDC	115 VDC	230 VDC
1	1 hp	1/4 hp	1 hp	1/4 hp
2	1 hp	1/4 hp	1 hp	1 hp

Poles	Enclosure With Starter	
	Hub Size	Through Feed Cat. #
1	1/2	NFSC G11 ①
	3/4	NFSC G21 ①
2	1/2	NFSC G12 ①
	3/4	NFSC G22 ①

Heater Table (see page 463)

With Square D Switches

Poles	Maximum HP Ratings	
	115-230 Volts AC	115-230 Volts DC
1	1 hp	
2	1 hp	3/4 hp

Poles	Enclosure With Starter	
	Hub Size	Through Feed Cat. #
1	1/2	NFSC D11 ①
	3/4	NFSC D21 ①
2	1/2	NFSC D12 ①
	3/4	NFSC D22 ①

Heater Table (Square D)

Full-Load Motor Current	Cooper Crouse-Hinds Symbol Number	Full-Load Motor Current	Cooper Crouse-Hinds Symbol Number
0.41-0.44	A.49	2.85-3.06	A3.95
0.45-0.49	A.54	3.07-3.45	A4.32
0.50-0.53	A.59	3.46-3.70	A4.79
0.54-0.58	A.65	3.71-4.07	A5.30
0.59-0.65	A.71	4.08-4.32	A5.78
0.66-0.71	A.78	4.33-4.90	A6.20
0.72-0.78	A.86	4.91-5.35	A6.99
0.79-0.85	A.95	5.36-5.85	A7.65
0.86-0.96	A1.02	5.86-6.41	A8.38
0.97-1.04	A1.16	6.42-6.79	A9.25
1.05-1.16	A1.25	6.80-7.57	A9.85
1.17-1.29	A1.39	7.58-8.15	A11.0
1.30-1.37	A1.54	8.16-8.98	A11.9
1.38-1.47	A1.63	8.99-9.67	A13.2
1.48-1.56	A1.75	9.68-9.95	A14.1
1.57-1.65	A1.86	9.96-10.8	A14.8
1.66-1.79	A1.99	10.9-12.1	A16.2
1.80-1.95	A2.15	12.2-13.1	A17.9
1.96-2.15	A2.31	13.2-13.9	A19.8
2.16-2.38	A2.57	14.0-15.0	A21.3
2.39-2.75	A2.81	15.1-16.0	A25.2
2.76-2.84	A3.61		

① Includes one interchangeable heater. Select heater suffix from table and add to catalog number. Example: NFSC-D11A.49



CHS Controls AB
Tel +46 42 38 61 00, Fax +46 42 38 61 29
chs@chscontrols.se www.chscontrols.se

NMN Series Manual Line Starters and Enclosures

600VAC Heavy Duty

Corrosion-Resistant
Dust-tight
Watertight
Weatherproof
NEMA 3, 4X, 12

2C

Applications:

- NMN manual line starters are for use in across-the-line starting of motors, motor protection and manual starting and stopping.

Features:

- Enclosures are made of Cooper Crouse-Hinds high-impact strength *Krydon*® fiberglass-reinforced polyester material which has excellent corrosion resistance and stability to heat.
- Factory installed dead end (NMN) or through feed (NMNC) hubs, 3/4" and 1" sizes.

Certifications and Compliances:

- NEMA/EEMAC 3, 4X and 12

Electrical Rating Ranges:

- Starter sizes 0, 1, 1P

Options:

- | Description | Suffix |
|--|--------|
| Undervoltage protection. Available with toggle operator only | U |
| Grounding plate – see page 646. | |
| Insulated, groundable type terminal block for grounded or ungrounded neutral can be supplied | S618 |



Toggle-operated manual starter with knockout

2C

Ordering Information

Starter	Enclosure with Starter					
	3/4" Hubs		1" Hubs			
NEMA Size	Poles	Max. HP 115V 230V 460/575V	Dead End Cat #	Through Feed Cat #	Dead End Cat #	Through Feed Cat #
M-0	2 (1 PH)	1 2	NMN ①220	NMNC ①220	NMN ①320	NMNC ①320
M-1	2 (1 PH)	2 3	NMN ①221	NMNC ①221	NMN ①321	NMNC ①321
M-1P	2 (1 PH)	3 5	NMN ①221P	NMNC ①221P	NMN ①321P	NMNC ①321P
M-0	3 (3 PH)	2 3 5	NMN ①230	NMNC ①230	NMN ①330	NMNC ①330
M-1	3 (1 PH) 3 (3 PH)	2 3 3 7½ 10	NMN ①231	NMNC ①231	NMN ①331	NMNC ①300
			Enclosure Only*			
			NMN ①200	NMNC ①200	NMN ①300	NMNC ①300

①Motor Starters: Insert appropriate symbol in Cat. No.

Manufacturer	Symbol
Allen-Bradley	AB
General Electric	G
Square D	D

Dimensions In Inches:

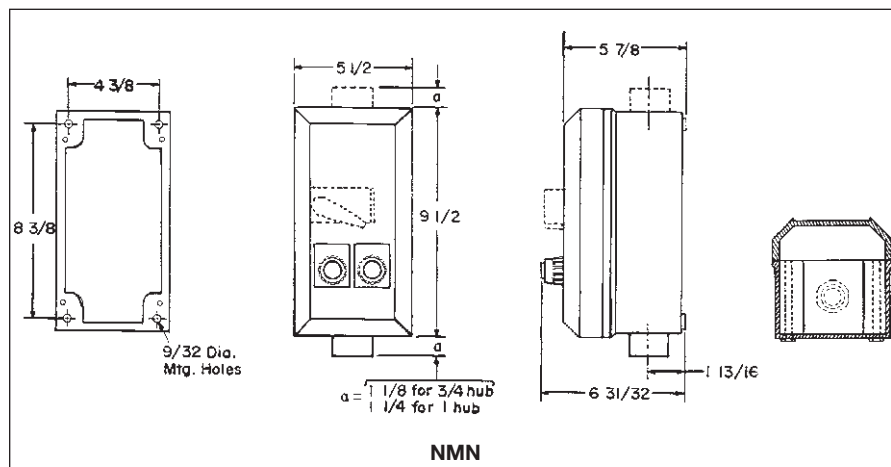

*Furnished with mounting plate and operator installed.

CHS Controls AB
Tel +46 42 38 61 00, Fax +46 42 38 61 29
chs@chscontrols.se www.chscontrols.se

Applications:

NMG magnetic line starters are used:

- For magnetic across-the-line starting of motors and remote starting and stopping
- For across-the-line starting of polyphase AC induction motors
- To provide motor running protection, undervoltage protection and remote starting and stopping

Features:

- Enclosures are made of Cooper Crouse-Hinds high-impact strength *Krydon*[®] fiberglass-reinforced polyester material which has excellent corrosion resistance and stability to heat.
- Unitized, strong and durable enclosure construction provides longer service life for equipment.
- Exterior parts of RESET button made of *Krydon* material.

Certifications and Compliances:

- NEMA/EEMAC: 3, 4X and 12

Electrical Rating Ranges:

- Starter sizes 0, 1, 2, 3, 4

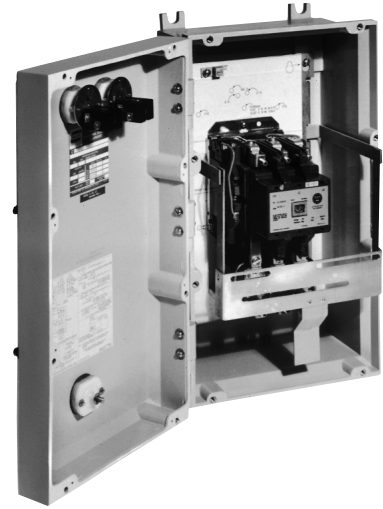

Magnetic line starter with optional hinged cover with START-STOP pushbuttons.

Options:

Description	Suffix
Hinged cover.....	NH
Pilot lights, 120 V primary – specify other primary voltages as required:	
Red pilot light.....	J1*
Green pilot light.....	J3*
LED pilot lights in place of standard incandescent pilot lamps.....	LED
Pushbutton (heavy duty, uses two device holes):	
START-STOP.....	PB13*
Selector switches (heavy duty):	
ON-OFF.....	RR17*
HAND-OFF-AUTO.....	RR18*
JOG-RUN-OFF.....	RR19*
Padlock attachment for:	
Pushbutton.....	S708
Control circuit transformer 480 / 240-120 volts, 50 or 60 hertz, (sizes 0 and 1-50VA, size 2-100VA, size 3-150VA, size 4-300VA):	
Fusible	
Secondary.....	FT
Primary and Secondary.....	FTPS
Automatic reset overload relay.....	S1
Less overload relays (contactor).....	C
Auxiliary Contact on Starter or Contactor:	
1NO/1NC.....	S781
2NO/2NC.....	S782
3NO/3NC.....	S783

Description

Time delay low voltage release for 3-wire control with 2, 4 or 6-second adjustment. For single-speed, non-reversing starters only. Control circuit voltage:

120 volt, 60 hertz.....	LVR1
240 volt, 60 hertz.....	LVR2
480 volt, 60 hertz.....	LVR3

Hubs (see "Note on Hubs") – see page 646
Grounding plate or bushing† – see page 646
Insulated, groundable type terminal block for a grounded or ungrounded neutral can be supplied..... S618

Information on other options or combination of options for a specific enclosure size is available on request.



CHS Controls AB
 Florettgatan 33
 SE-254 67 Helsingborg, Sweden
 Tel +46 42 38 61 00, Fax +46 42 38 61 29
 chs@chscontrols.se
 www.chscontrols.se

†Type GP grounding plate only in NMG0710 enclosure.

*For optional devices or control circuit transformer, use next larger enclosure size. For NMG0714, two device holes maximum.

NMG Series Magnetic Line Starters and Enclosures

600VAC Heavy Duty

Corrosion-Resistant
Dust-tight
Watertight
Weatherproof
NEMA 3, 4X, 12

2C

Ordering Information

To order an enclosure complete with starter, insert the manufacturer's symbol in the designated position of the catalog number. Symbols are shown in the footnote at the bottom of this page. Specify HP, voltage, frequency, RPM, type and full load ampere rating of motor – or specify ampere rating of heaters.

Starters are furnished with three heaters. Enclosures only can be ordered. Select from listings.

Single-Speed, Non-Reversing

Motor Starter		Enclosure		
Max. HP Polyphase	Volts (AC)	NEMA Size	With Starter Cat. #	Without Starter Cat. #
2	120	0	NMG0710 ①6130	NMG0710
3	120	1	NMG0710 ①6131	NMG0710
3	240	0	NMG0710 ①6230	NMG0710
5	480	0	NMG0710 ①6430	NMG0710
5	600	0	NMG0710 ①6530	NMG0710
7½	120	2	NMG0714 ①6132	NMG0714
7½	240	1	NMG0710 ①6231	NMG0710
10	480	1	NMG0710 ①6431	NMG0710
10	600	1	NMG0710 ①6531	NMG0710
15	120	3	NMG1018 ①6133	NMG1018
15	240	2	NMG0714 ①6232	NMG0714
25	480	2	NMG0714 ①6432	NMG0714
25	600	2	NMG0714 ①6532	NMG0714
30	240	3	NMG1018 ①6233	NMG1018
50	240	4	NMG1024 ①6234*	NMG1024
50	480	3	NMG1018 ①6433	NMG1018
50	600	3	NMG1018 ①6533	NMG1018
100	480	4	NMG1024 ①6434*	NMG1024
100	600	4	NMG1024 ①6534*	NMG1024

*NEMA Size 4 Allen-Bradley starter must be in NMG1426 enclosure.

① Motor Starters:

Manufacturer	Symbol
Allen-Bradley	AB
Square D	D
Cutler-Hammer	C
General Electric	G
Westinghouse	W

Information on other starter manufacturers on request.

Ordering Information when adding options

When adding options to NMG series enclosures, the base catalog number must be changed according to the table below.

NEMA Size	Enclosure Cat. #	Enclosure w/Options
0, 1	NMG0710	NMG0714
2	NMG0714	NMG1018
3	NMG1018	NMG1024
4	NMG1024	NMG1426

Example: A NEMA size 4, 480 V Westinghouse starter with START-STOP pushbuttons would be Cat. No. NMG1426-W6434-PB13.

Note on Hubs: The following number and sizes of hubs (not mounted) are included when magnetic starters are ordered complete. If enclosures only are ordered, hubs must be ordered separately (see "Options").

Starter Size	Number Included	Hub Size
0	3	¾
1	1	¾
2	2	1½
3	1	¾
3	2	2
4	1	¾
4	2	2½

Dimensions† In Inches:

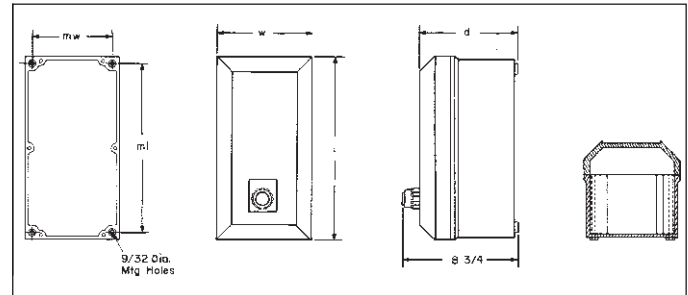

NMG0710 & 0714

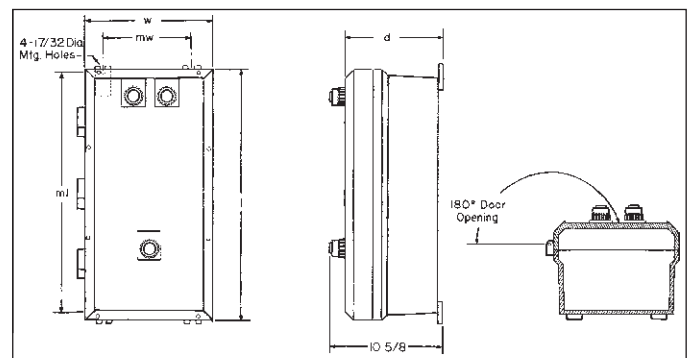

NMG1018 & 1024

Enclosure Cat. #	Outside Dimensions			Mounting Dimensions	
	l	w	d	ml	mw
NMG0710	10½	7½	7	9⅝	6⅝
NMG0714	14½	7½	7	13⅝	6⅝
NMG1018	19 ¹³ / ₃₂	11 ¹³ / ₃₂	8 ²³ / ₃₂	19⅝	7⅞
NMG1024	25 ¹³ / ₃₂	11 ¹³ / ₃₂	8 ²³ / ₃₂	25⅝	7⅞

†Not to be used for construction purposes unless approved.



CHS Controls AB
 Florettgatan 33
 SE-254 67 Helsingborg, Sweden
 Tel +46 42 38 61 00, Fax +46 42 38 61 29
 chs@chscontrols.se
 www.chscontrols.se

**CHS Controls AB**

Florettgatan 33
SE-254 67 Helsingborg, Sweden
Tel +46 42 38 61 00, Fax +46 42 38 61 29
chs@chscontrols.se
www.chscontrols.se

Description	Page No.
Application/Selection	see page 476
Auxiliary Circuit Breakers & Enclosures	
EFD, EFDC Series	see page 493
Thermal Magnetic Circuit Breakers & Enclosures	
General Information and Dimensions	
EPC Series	see pages 482–483
FLB Series	see page 487
EBMB Series	see pages 478–481
Non-Interchangeable Trip	
100 / 150 ampere frame	
EPC Series	see page 484
FLB Series	see page 488
EBMB Series	see page 480
EIB Series	see page 477
NCB Series	see page 494
225 / 250 ampere frame	
EPC Series	see page 486
FLB Series	see page 492
EBMB Series	see page 480
NCB Series	see page 495
400 ampere frame	
EBMB Series	see page 480
Interchangeable Trip	
225 / 250 ampere frame	
FLB Series	see page 492
EBMB Series	see page 480
400 ampere frame	
EBMB Series	see page 480
NCB Series	see page 495
600 / 800 ampere frame	
EBMB Series	see page 480
1000 ampere frame	
EBMB Series	see page 480



CHS Controls AB
 Florettgatan 33
 SE-254 67 Helsingborg, Sweden
 Tel +46 42 38 61 00, Fax +46 42 38 61 29
chs@chscontrols.se
www.chscontrols.se

Application and Selection Quick Selector Chart



CHS Controls AB
 Florettgatan 33
 SE-254 67 Helsingborg, Sweden
 Tel +46 42 38 61 00, Fax +46 42 38 61 29
 chs@chscontrols.se
 www.chscontrols.se

Applications:

Circuit breakers and their appropriate enclosures are used:

- In conjunction with service entrance, lighting, heating, appliance and motor protection circuits
- To provide disconnect means
- For short circuit protection and thermal time delay overload protection
- In various types of damp, wet, corrosive and hazardous areas

Considerations for Selection:

Considerations for selection of proper enclosure:

- The environment of the enclosure location in terms of NEC/CEC compliance and NEMA/EEMAC type required
- The size and type of circuit breaker required for the particular application
- See "Quick Selector" below for guidance

Options:

Many options are available on:

- Material and finishes where special atmospheric conditions prevail
- Special features for specific applications. See individual listings for available options

Quick Selector Chart

Enclosures for Circuit Breakers									
Encl.	NEC/CEC – Hazardous Area Certifications and Compliances	NEMA/EEMAC Encl. Type	Circuit Breaker						
			Type	Ampere Rating Range	Voltage Range	Manufacturer and Frame Size	No. of Poles	Inter-changeable Trip	Enclosure Cover Construction
EFD, EFDC	Cl. I, Div. 1 & 2, Groups B, C, D Cl. II, Div. 1, Groups E, F, G Cl. II, Div. 2, Groups F, G Cl. III	3, 7BCD, 9EFG	Thermal-Magnetic	15–30	120AC	Sq. D – QOU	1	No	Bolted/ Ground Joint
EBMB	Cl. I, Div. 1 & 2, Groups B, C, D Cl. II, Div. 1, Groups E, F, G Cl. II, Div. 2, Groups F, G Cl. III	3R, 4, 7BCD, 9EFG, 12	Thermal-Magnetic	15–800	120AC to 600AC 125DC to 250DC	G.E. – TEB, TED, TFJ, TFK, TJJ, TJK, TKMA Sq. D – FAL, KAL, LAL, MAL Cut.-Ham. – EHD, FD, FDB, JD, JDB, KD, KDB,	1, 2, 3	Yes	Bolted/ Ground Joint/ Gasketed
EPC	Cl. I, Div. 1 & 2, Groups C, D Cl. II, Div. 1, Groups E, F, G Cl. II, Div. 2, Groups F, G Cl. III	3, 4, 7CD, 9EFG	Thermal-Magnetic	15–250	120AC to 600AC 125DC to 250DC	G.E. – TEB, TED, TFJ Sq. D – FAL, KAL Cut.-Ham. – EHD, FD, FDB, JD, JDB	1, 2, 3	Yes	Threaded
FLB	Cl. I, Div. 1 & 2, Groups C, D Cl. II, Div. 1, Groups E, F, G Cl. II, Div. 2, Groups F, G Cl. III	3, 7CD, 9EFG	Thermal-Magnetic	15–225	120AC to 600AC 125DC to 250DC	G.E. – TEB, TED, TFJ, TFK Sq. D – FAL, KAL Cut.-Ham. – EHD, FD, FDB, JD, JDB	1, 2, 3	Yes	Threaded
EIB	Cl. I, Div. 1 & 2, Groups B, C, D Cl. I, Zones 1 & 2 Cl. II, Div. 1, Groups E, F, G Cl. III	3, 3R, 4, 7BCD, 9EFG	Magnetic	15–100	480AC to 600AC	Cut. Ham. – EG	3	No	Bolted/ Ground Joint
NCB	N/A	3, 4X, 12	Thermal-Magnetic	15-400	240AC to 600VAC 250DC	G.E. – TEB, TED, TFJ Sq. D – FAL, KAL, LAL Cut.-Ham. – EB, EHB, EHD, FD, FDB, JD, JDB	2, 3	Yes	Hinged, screw and gasket

Compact Circuit Breaker Assemblies With Covers

Cl. I, Div. 1 & 2, Groups B, C, D

Cl. I, Zones 1 & 2

Cl. II, Div. 1, Groups E, F, G

Cl. III

NEMA 3, 3R, 4, 7BCD, 9EFG

UL Standard: 1203 cUL to CSA C22.2 No. 30

The EIB Series Compact Circuit Breaker Assemblies are an innovative line of explosionproof motor control now being offered by Cooper Crouse-Hinds. The EIB series utilizes the EJB style D enclosure with its bolted construction, NEMA 4 environmental protection and Class I, Division 1, Group B, C and D hazardous area ratings. The EIB series is a cost-effective solution for circuit breaker protection and utilizes the Cutler-Hammer Type EG circuit breakers. Circuit breaker protection is available from 15 to 100 amps.

Features:

- Small compact footprint requires less mounting space and reduces enclosure cost
- Rotary handle operator mounted on cover assembly provides clear indication of on, off and trip positions
- No internal fork operator, eliminating potential damage to breaker toggle
- Trip position easily identified from a distance
- Neoprene cover gasket provides UL Type 4 (hose-tight) environmental rating
- Detachable mounting feet offer flexible mounting alternatives - no need to replace the entire enclosure if a mounting foot is broken
- Stainless steel hinges provide extreme durability and easy access to inside of enclosure for wiring and maintenance
- (2) 1½" NPT conduit entries, one on top and one on bottom for easy top or bottom feed of conductors. For field addition of breather and/or drain; holes come plugged

Certifications and Compliances:

- Class I, Divisions 1 & 2, Groups B, C & D
- Class I, Zones 1 & 2
- Class II, Division 1, Groups E, F and G
- Class III
- Enclosure type 3, 3R, 4, 7BCD, 9EFG
- NEMA 3, 3R, 4, 7BCD, 9EFG
- UL Standard 886
- cUL to CSA C22.2 No. 30

Standard Materials:

- Body and Cover – Copper-free aluminum
- Gasket – Neoprene
- Cover Bolts – Steel
- Hinges – Stainless Steel
- Mounting Plate Sheet – Aluminum

Finishes:

- Copper-free Aluminum – Natural
- Steel – Electrogalvanized

Options:

Description	Suffix
Insulated Neutral Lug	S146
Grounded Neutral Lug Kit with Connectors for 50, 100 & 225 Amps	S178
External Ground Stud	S214
Breather and Drain	S756V
Epoxy Powder Coat Finish (exterior only)	S752
Epoxy Powder Coat Finish (exterior and interior)	S753

Electrical Ratings:

- 480 volts, 600 volts
- 3 poles
- 10,000 AIC max.

Ordering Information

Circuit Breaker Rating (amps)	Enclosure Only	Enclosure with Circuit Breaker
15	EIBA	EIBA3015
20	EIBA	EIBA3020
25	EIBA	EIBA3025
30	EIBA	EIBA3030
35	EIBA	EIBA3035
40	EIBB	EIBB3040
45	EIBB	EIBB3045
50	EIBB	EIBB3050
60	EIBB	EIBB3060
70	EIBB	EIBB3070
80	EIBB	EIBB3080
90	EIBB	EIBB3090
100	EIBB	EIBB3100

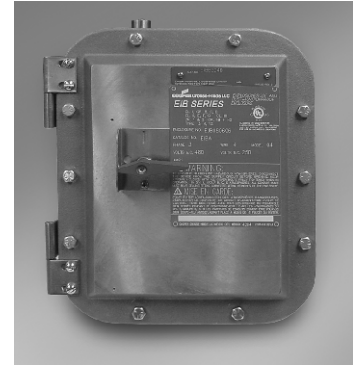

Weights:

EIBA	39 lbs.
EIBB	58 lbs.



CHS Controls AB
 Florettgatan 33
 SE-254 67 Helsingborg, Sweden
 Tel +46 42 38 61 00, Fax +46 42 38 61 29
 chs@chscontrols.se
 www.chscontrols.se

Dimensions In Inches:

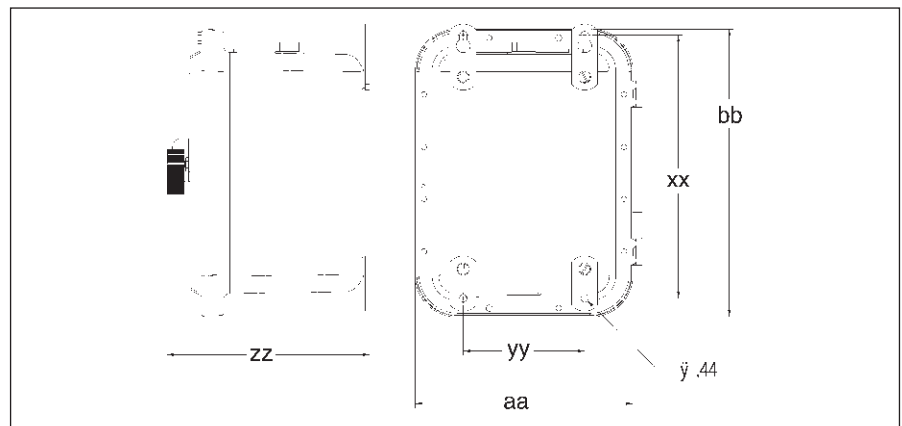

Dimension	Size A	Size B
aa	10.47"	12.53"
bb	12.47"	16.53"
xx	11.13"	15.13"
yy	5.0"	7.0"
zz	9.6"	11.66"
Mounting Holes	7/16"	7/16"

Cl. I, Div. 1 & 2, Groups B, C, D
 Cl. II, Div. 1, Groups E, F, G
 Cl. II, Div. 2, Groups F, G
 Cl. III
 NEMA 3, 3R, 4 \ddagger , 7BCD, 9EFG, 12

Explosionproof
 Dust-Ignitionproof
 Raintight
 Wet Locations
 Watertight

Applications:

Spectrum™ EBM hinged cover motor control enclosures are used:

- For general motor control and circuit protection – indoors and outdoors – in damp, wet, dirty, dusty hazardous locations without the need for a protective shelter.
- In areas where frequent washdowns are necessary or where heavy rain or water spray is prevalent.
- To provide line disconnect means and short circuit protection.
- For service entrance, feeder or branch circuit protection for lighting, heating, appliance and motor circuits.
- On switchracks or other assemblies where it's desired that motor control be centrally located.

Features:

- Rugged, corrosion resistant, cast copper-free aluminum construction (less than 0.4 of 1%).
- Circuit breaker operating handle located through the right side wall of the body permits visual confirmation of correct component assembly and operation.
- Total compliance to the wiring end room requirements of the National Electrical Code®.
- Semi-clamshell enclosure design, with an external flanged ground joint between body and cover makes interior components more accessible.
- Minimum enclosure-to-enclosure spacing with little interference between the opened cover and an adjacent enclosure.
- Copper-free aluminum hinges allow the cover to swing well out of the way.
- Stainless steel, quick release, captive, hex head cover bolts. Stainless steel springs provide clear indication cover bolts are fully retracted from body.
- Versatile, internal operating mechanisms allow for field adjustment to accommodate popular manufacturers' breakers.
- Simple, straightforward installation of breaker on pre-drilled mounting plate within enclosure. Mounting plate also field removable.
- Circuit breaker external operating handle can be padlocked in either "ON" or "OFF" positions.
- Neoprene cover gasket permanently attached to the cover seals out moisture.
- Bodies have top and bottom drilled and tapped entrances for power conduits and control conduits. Removable reducers are supplied, as standard, to accommodate smaller size conduits. All conduit entrances are plugged.
- Tap-on mounting feet.
- Optional EMPS control devices may be added to enclosure cover.
- Steel bracket for lifting larger enclosures during installation supplied as standard.



Spectrum EBM motor control enclosures accommodate popular makes of circuit breakers.

Certifications and Compliances:

- NEC/CEC:
 - Class I, Division 1 & 2, Groups B, C, D
 - Class II, Division 1, Groups E, F, G
 - Class II, Division 2, Groups F, G
 - Class III
- UL Standards UL1203 – Hazardous (classified) locations/CSA Standards: C22.2 No. 30
- UL Subject 2062 - High AIC rating (Interrupting Capacity) For Groups C & D only
 - 240V 65,000 RMS Symm. Amperes
 - 480V 50,000 RMS Symm. Amperes
 - 600V 25,000 RMS Symm. Amperes
- NEMA 3, 3R, 4 \ddagger , 7BCD, 9EFG, 12

Standard Materials:

- Body and cover – copper-free aluminum
- Operating handle – copper-free aluminum
- Operating shaft and bushing – stainless steel
- Interior parts – sheet steel, electrogalvanized
- Cover bolts, washers and retractile springs – stainless steel

Electrical Rating Ranges:

- Circuit breakers – 100, 150, 225, 250, 400, 600, 800, 1000* ampere frame sizes



CHS Controls AB

Florettgatan 33
 SE-254 67 Helsingborg, Sweden
 Tel +46 42 38 61 00, Fax +46 42 38 61 29
 chs@chscontrols.se
 www.chscontrols.se

‡Enclosure not suitable for NEMA 4 with cover mounted operators.

*1000 Ampere Frame (max. 800 ampere trip)

National Electrical Code is a Registered Trademark of The National Fire Protection Association.

EBMB Series Circuit Breakers and Enclosures

Cl. I, Div. 1 & 2, Groups B, C, D
 Cl. II, Div. 1, Groups E, F, G
 Cl. II, Div. 2, Groups F, G
 Cl. III
 NEMA 3, 3R, 4†, 7BCD, 9EFG, 12

Explosionproof
 Dust-Ignitionproof
 Raintight
 Wet Locations
 Watertight

3C

Options:

The following options are available from factory by adding suffix to catalog number. Suffixes are added alphanumerically.

Catalog Number System

EBMBB-①-WT30FDB36-②

- ① Options in this position are additions to the enclosure and should be listed alphanumerically.
- ② Options in this position are modifications to the circuit breaker and should be listed alphanumerically.

Description	Position in Cat. #	Suffix
Ambient compensated circuit breaker trip setting.....	②	AC
Pilot light, 120VAC, red jewel, w/blank indicating plate.....	①	J1†
Pilot light, 120VAC, green jewel, w/blank indicating plate.....	①	J3 †
LED pilot lights in place of standard incandescent pilot lamps.....	①	LED
Start-stop pushbuttons (requires 2 spaces).....	①	PB23 ††
Space heater, 120 volt, 25 watts.....	①	R11
Space heater, 240 volt, 25 watts.....	①	R22
Space heater, 480 volt, 25 watts.....	①	R44
Insulated neutral w/2 connectors.....	①	S146
Grounded neutral stud w/3 connectors (50, 100, 225 amp).....	①	S178
Std. drain, Class I, B, C & D; Class II, E F & G, Class III.....	①	S756 ‡
Std. breather & drain, Class I, B, C & D; Class II, E, F & G; Class III.....	①	S756V ‡
External epoxy finish.....	①	S752
Internal and external epoxy finish.....	①	S753
Aux. switch on circuit breaker, 1A & 1B contacts.....	②	S784
Aux. switch on circuit breaker, 2A & 2B contacts.....	②	S785
12 point term. block – 30 amp, 300 V.....	①	S786
General purpose control relay, 4 pole N.O., contacts rated 10A @ 600V, coil 120VAC, 50–60 Hertz.....	①	S787



EBMB Series circuit breaker enclosures are available with breakers from 100 to 1000* amp frame sizes.

3C



CHS Controls AB
 Florettgatan 33
 SE-254 67 Helsingborg, Sweden
 Tel +46 42 38 61 00, Fax +46 42 38 61 29
chs@chscontrols.se
www.chscontrols.se

*1000 Ampere Frame (max. 800 ampere trip.)

†If desired, markings on indicating plates may be added to catalog number. To select from the list of standard markings and DSL Legend Plate listings see page 433.

‡Enclosure not suitable for NEMA 4 with cover mounted operators.

Ordering Information:

- To order an enclosure complete with circuit breaker, insert the manufacturer's symbols in the designated positions of the catalog number. Symbols are shown below.
- Enclosures can be ordered without circuit breakers. Select from listings below.

EBMB Series Enclosures for Circuit Breakers

Circuit Breaker			Enclosures			
Poles \ddagger	Voltage Rating	Circuit Breaker Frame Size	Without Circuit Breaker Cat. #	Circuit Breaker Amp Rating	With Circuit Breaker Cat. #	
3	240VAC or 125–250VDC	100 Amp. Frame	EBMBA *	15A through 70A	EBMBA DT $\textcircled{2}$ FAL32	
3	240VAC or 125–250VDC	150 Amp. Frame	EBMBA † §	10A through 70A	EBMBA TT $\textcircled{2}$ TEB32	
3	480VAC or 250VDC	100 Amp. Frame	EBMBA *	15A through 70A	EBMBA $\textcircled{1}\textcircled{2}\textcircled{3}$ 34	
3	480VAC or 250VDC	150 Amp. Frame	EBMBA † §	10A through 70A	EBMBA TT $\textcircled{2}$ TED34	
3	600VAC	100 Amp. Frame	EBMBA *	15A through 70A	EBMBA DT $\textcircled{2}$ FAL36	
3	600VAC	150 Amp. Frame	EBMBA † § ■	10A through 70A	EBMBA $\textcircled{1}\textcircled{2}\textcircled{3}$ 36	
3	240VAC or 125–250VDC	100 Amp. Frame	EBMBB *	15A through 100A	EBMBB DT $\textcircled{2}$ FAL32	
3	240VAC or 125–250VDC	150 Amp. Frame	EBMBB † §	10A through 150A	EBMBB TT $\textcircled{2}$ TEB32	
3	480VAC or 250VDC	100 Amp. Frame	EBMBB *	15A through 100A	EBMBB $\textcircled{1}\textcircled{2}\textcircled{3}$ 34	
3	480VAC or 250VDC	150 Amp. Frame	EBMBB † §	10A through 150A	EBMBB TT $\textcircled{2}$ TED34	
3	600VAC	100 Amp. Frame	EBMBB *	15A through 100A	EBMBB DT $\textcircled{2}$ FAL36	
3	600VAC	150 Amp. Frame	EBMBB † § ■	15A through 150A	EBMBB $\textcircled{1}\textcircled{2}\textcircled{3}$ 36	
3	600VAC	250 Amp. Frame	EBMBG $\textcircled{2}$ ▲	70A through 250A	EBMBG $\textcircled{1}\textcircled{2}\textcircled{3}$ 36	
3	600VAC or 250VDC	400 Amp. Frame	EBMBK ▼	100A through 400A	EBMBK $\textcircled{1}\textcircled{2}\textcircled{3}$ 36	
3	600VAC or 250VDC	600 Amp. Frame	EBMBL ♠	250A through 600A	EBMBL WT $\textcircled{2}\textcircled{3}$ 36	
3	600VAC or 250VDC	800 Amp. Frame	EBMBL ♥	300A through 800A	EBMBL WT $\textcircled{2}\textcircled{3}$ 36	
3	600VAC or 250VDC	1000 Amp. Frame	EBMBL	125A through 800A (max.)	EBMBL DT $\textcircled{2}\textcircled{3}$ 36	

①Circuit Breakers:

Manufacturer	Symbol
Cutler-Hammer	WT
General Electric	TT
Square D	DT

② Select Trip Setting from below:

100 Amp Frame (EHD, FAL)* – 15, 20, 25, 30, 35, 40, 45, 50, 60, 70, 80, 90, 100
 150 Amp. Frame (TDB, TEB, TED)†§■ – 10, 15, 20, 25, 30, 35, 40, 45, 50, 60, 70, 80, 90, 100, 110, 125, 150
 225 / 250 Amp Frame (JD, JDB, KAL, TFJ, TFK) $\textcircled{2}$ ▲ – 70, 80, 90, 100, 110, 125, 150, 175, 200, 225, 250
 400 Amp. Frame (KD, KDB, LAL, TJJ, TJK)▼ – 100, 125, 150, 175, 200, 225, 250, 300, 350, 400
 600 Amp. Frame (LD, TJK)♠ – 250, 300, 350, 400, 450, 500, 600
 800 Amp Frame (MD, TKMA)♥ – 300, 350, 400, 450, 500, 600, 700, 800
 1000 Amp Frame (MAL) – 125, 150, 175, 200, 225, 250, 300, 350, 400, 450, 500, 600, 700, 800

③Select Circuit Breaker Frame Type based on frame size, voltage, and manufacturer desired:

Manufacturer	100 Amp. Frame			150 Amp. Frame			250 Amp. Frame $\textcircled{2}$ ▲	400 Amp. Frame	600 Amp. Frame	800 Amp. Frame	1000 Amp. Frame
	240VAC	480VAC	600VAC	240VAC	480VAC	600VAC	600VAC	600VAC	600VAC	600VAC	600VAC
Cutler-Hammer	–	EHD	–	–	–	FDB	JD $\textcircled{2}$ JDB $\textcircled{2}$	KD $\textcircled{2}$ KDB $\textcircled{2}$	LD	MD	–
General Electric	TEB	–	–	–	TED	TED	TFK $\textcircled{2}$ TFJ $\textcircled{2}$	TJK $\textcircled{2}$ TJJ $\textcircled{2}$	TJK	TKMA	–
Square D	FAL	FAL	FAL	–	–	–	KAL	LAL	–	–	MAL

☆–Interchangeable Trip Unit
 ✚–Non-Interchangeable Trip Unit

‡ Enclosure not suitable for NEMA 4 with cover mounted operators.

* Depending on availability from the circuit breaker manufacturer 1 and 2 pole can be furnished. Information available upon request. Example of an adjusted part number - EBMBB WT100EDH34 becomes EBMBB WT100EDH24.

† EBMBB will accept 15 through 70 amp. trip, EBMBB will accept 15 through 100 amp. trip.

‡ EBMBB will accept 10 through 70 amp. trip, EBMBB will accept 10 through 150 amp. trip.

§ General Electric TEB frame available 10 through 100 amp. trip. TED frame available 10 through 150 amp. trip.

■ Westinghouse FDB frame available 15 through 150 amp. trip.

⊕ General Electric TFJ and TFK types are 225 amp. frame, available 70 through 225 amp. trip.

▲ Westinghouse JD and JDB types are 250 amp. frame, available 70, 90, 100 and 125 through 250 amp. trip.

▼ Westinghouse KD and KDB frames available 100 through 400 amp. trip. Square D LAL and General Electric TJJ and TJK frames available 125 through 400 amp. trip.

♠ Westinghouse LD frame available 300 through 400 and 500, 600 amp. trip.

♥ Westinghouse MD frame available 400 and 500 through 800 amp. trip.



CHS Controls AB
 Tel +46 42 38 61 00, Fax +46 42 38 61 29
 chs@chscontrols.se www.chscontrols.se

EBMB Series Circuit Breakers and Enclosures

Cl. I, Div. 1 & 2, Groups B, C, D
 Cl. II, Div. 1, Groups E, F, G
 Cl. II, Div. 2, Groups F, G
 Cl. III
 NEMA 3, 3R, 4†, 7BCD, 9EFG, 12

Explosionproof
 Dust-Ignitionproof
 Raintight
 Wet Locations
 Watertight

3C

Dimensions In Inches:

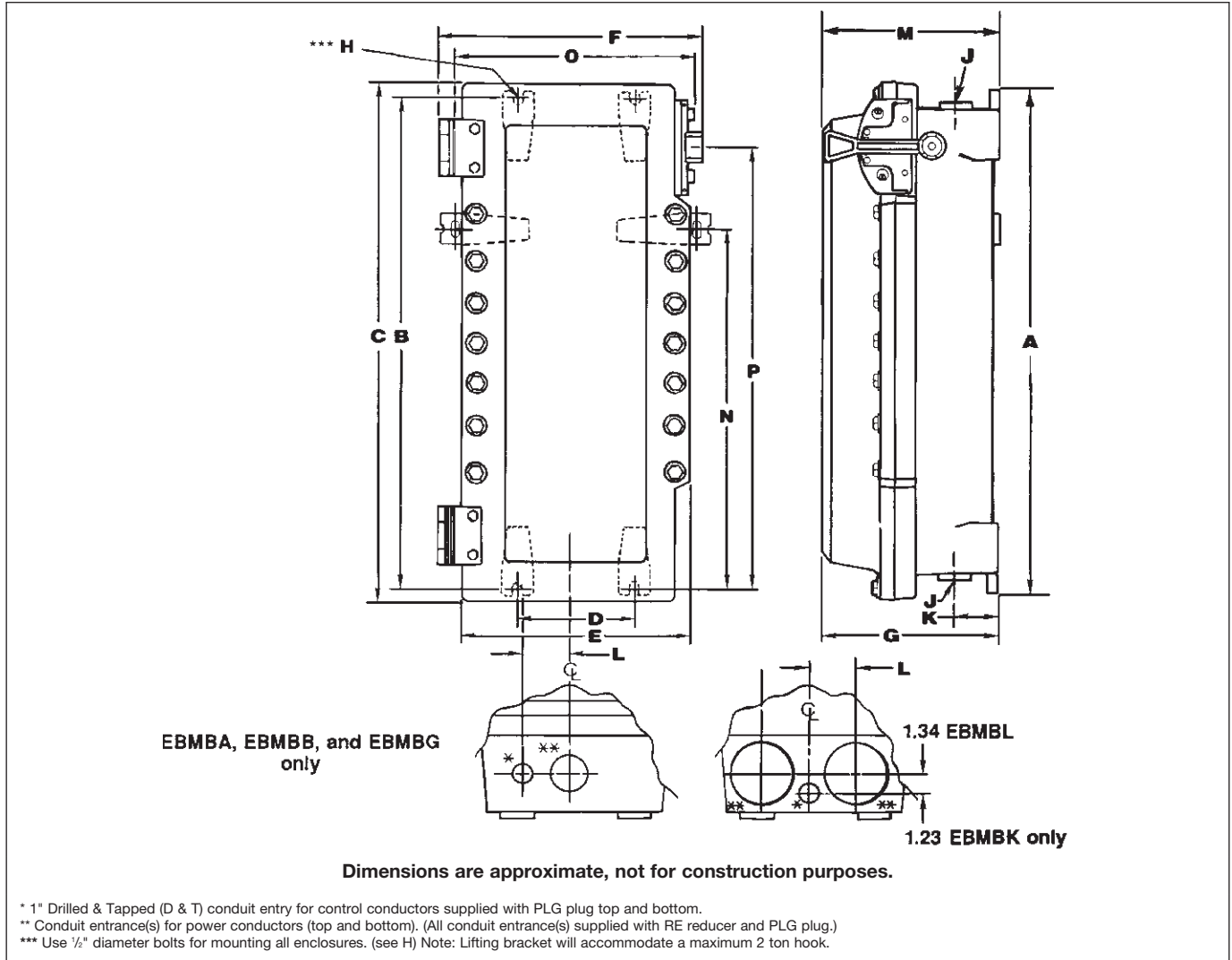

3C

Enclosure Only Cat. #	Enclosure Size Symbol	Dimensions								J** Conduit Entry Trade Size		Dimensions					
		A	B	C	D	E	F	G	D&T§	w/RE	K	L	M	N	O	P	
100 Amp Frame																	
EBMBA	A	18.25	17.25	19.40	6.00	13.03	14.78	10.25	2"	1.5"	3.25	3.13	10.25	—	—	14.50	
100 and 150 Amp Frame																	
EBMBB	B	25.75	24.75	26.90	6.00	13.03	14.78	10.25	2"	1.5"	3.25	3.13	10.25	—	—	22.00	
225 and 250 Amp Frame																	
EBMBG	G	37.50	36.50	39.28	6.00	13.03	14.78	10.25	3.0"	2.5"	3.25	3.13	10.25	—	—	34.06	
400 Amp Frame																	
EBMBK	K	43.12	41.50	42.65	12.00	17.65	20.28	10.92	(2)3"	(2)2.5"	3.25	3.00	10.92	—	—	29.23	
600, 800 and 1000 Amp Frame†																	
EBMBL	L	53.25	51.50	53.28	12.00	17.90	20.58	13.03	(2)4"	(2)3.5"	4.00	3.50	13.13	41.50	18.40	29.88	

†1000 Ampere Frame (max. 800 ampere trip)
 ‡Enclosure not suitable for NEMA 4 with cover mounted operators. Breather and drain entries must be plugged for NEMA 4 rating.
 §Drilled & Tapped.

CHS Controls AB
 Tel +46 42 38 61 00, Fax +46 42 38 61 29
 chs@chscontrols.se www.chscontrols.se

Cl. I, Div. 1 & 2, Groups C, D Explosionproof
 Cl. II, Div. 1, Groups E, F, G Dust-Ignitionproof
 Cl. II, Div. 2, Groups F, G Raintight
 Cl. III Wet Locations
 NEMA 3, 4, 7CD, 9EFG Watertight

Applications:

EPC Circuit Breakers and Enclosures are used:

- For service entrance*, feeder or branch circuit protection for lighting, heating, appliance and motor circuits
- In areas made hazardous due to the presence of flammable vapors, gases or combustible dusts
- In damp, wet or corrosive locations
- Indoors or outdoors at petroleum refineries, chemical or petrochemical plants and other process industry facilities where similar hazards exist
- To provide disconnect means, short circuit protection and thermal time delay overload protection

Features:

- Quick-opening covers – less than two turns to remove or install
- Three section design for ease of installation
- Water-shedding construction with female threads on top cover, male threads on bottom cover, and top cover skirted
- Specially located stops and locks insure adequate thread engagement and prevent overtightening
- Separate replaceable mounting bracket attached to the rear of the body provides three-point suspension for quick installation and leveling – one keyhole slot at top and two open slots at bottom
- Bodies have two taper-tapped conduit hubs with integral bushings on the top, and two more directly below
- Mounting plates are supplied with all necessary holes and hardware to attach any of the circuit breakers shown in the catalog listings. Breaker and interior mounting frames are easily removed as a unit, providing free access to the wiring chamber
- Breaker is operated by an external handle which can be padlocked in either "ON" or "OFF" positions by as many as three padlocks. Breaker is trip-free of the handle and will open under short circuit or overload, even if the handle is locked in the "ON" position

Certifications and Compliances:

- NEC/CEC
 - Class I, Division 1 & 2, Groups C, D
 - Class II, Division 1, Groups E, F, G
 - Class II, Division 2, Groups F, G
 - Class III
- NEMA: 3, 4, 7CD, 9EFG
- UL Standard: 698
- CSA: C22.2 No. 30

Standard Materials:

- Bodies and covers – copper-free aluminum
- Operating handles – copper-free aluminum
- Operating shafts – stainless steel
- Interior parts – sheet steel

Standard Finishes:

- Copper-free aluminum – natural
- Stainless steel – natural
- Sheet steel – electrogalvanized

*Suffix S146 insulated material must be used to comply with NEC requirements for service entrance.

‡Application is limited by circuit breaker design – Consult Factory.

§Not suitable for NEMA 4.



Options:

The following special options are available from factory by adding suffix to Cat. #:

Description	Suffix
Auxiliary Switch‡	
1A/1B (1P2T).....	S784
2A/2B (2P2T).....	S785
Insulated neutral with 2 connectors (100, 150 and 225 amp.)	S146
Grounded neutral stud with 3 connectors (100, 150 and 225 amp.).....	S178
Side bosses drilled and tapped same size as standard hubs.	S366
Back boss drilled and tapped same size as standard hubs...	S367
Standard Breather (Class I, Groups C, D; Class II, Groups E, F, G; Class III).....	S219
Standard Drain (Class I, Groups C, D; Class II, Groups E, F, G; Class III).....	S198
Standard Breather and Drain (Class I, Groups C, D; Class II, Groups E, F, G; Class III).....	S198V
Universal Breather-Drain (Class I, Groups C, D; Class II, Groups F, G).....	S454§
(2) Universal Breather-Drains (Class I, Groups C, D; Class II, Groups F, G).....	S454V§

Electrical Rating Ranges:

- 100, 150, 225, 250 ampere frame sizes



CHS Controls AB
 Florettgatan 33
 SE-254 67 Helsingborg, Sweden
 Tel +46 42 38 61 00, Fax +46 42 38 61 29
 chs@chscontrols.se
 www.chscontrols.se

EPC Series Circuit Breakers and Enclosures

Cl. I, Div. 1 & 2, Groups C, D Explosionproof
 Cl. II, Div. 1, Groups E, F, G Dust-Ignitionproof
 Cl. II, Div. 2, Groups F, G Raintight
 Cl. III Wet Locations
 NEMA 3, 4, 7CD, 9EFG Watertight

3C

Dimensions In Inches*

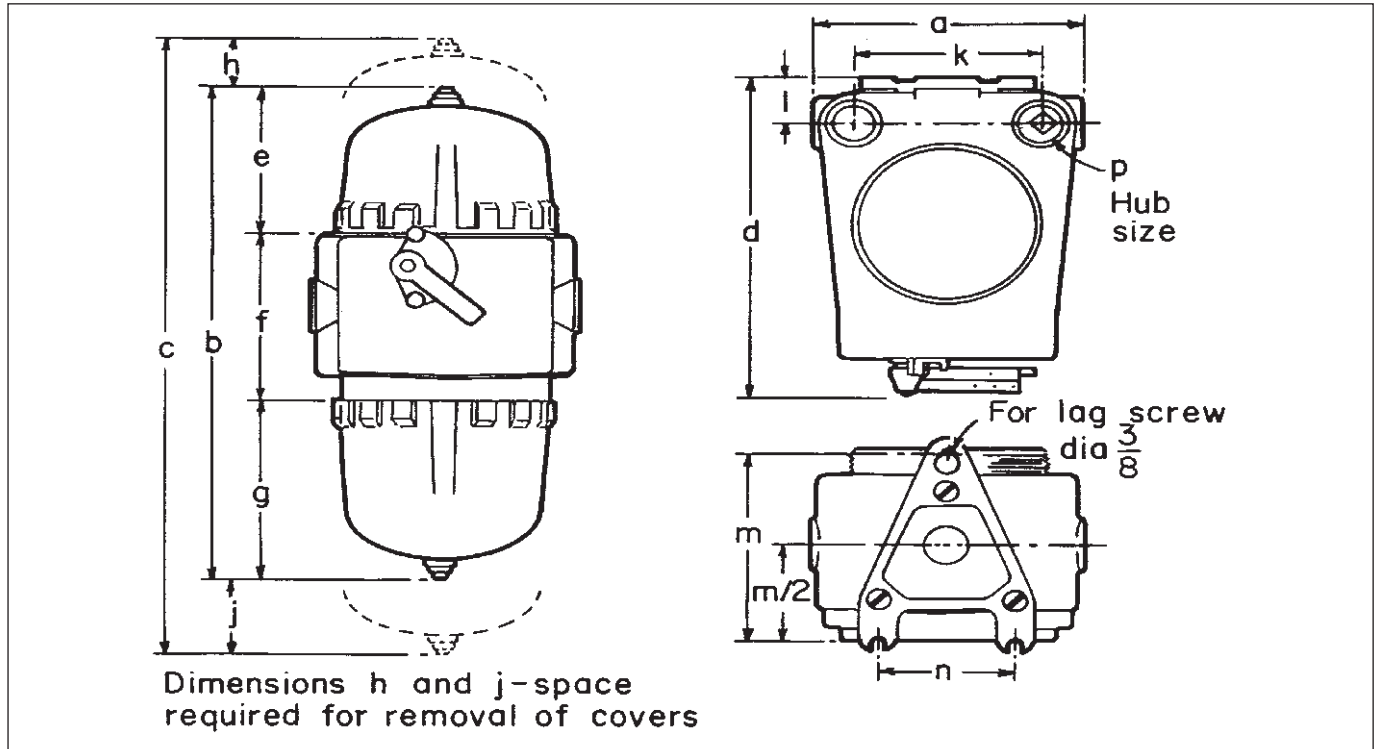

	EPC377	EPC387	EPC317
Int. Dia.	7"	7"W	11"
a	10 ⁵ / ₈	12 ¹³ / ₁₆	16 ¹ / ₈
b	19 ⁹ / ₁₆	19 ¹³ / ₁₆	25 ¹ / ₂
c	23 ¹³ / ₁₆	23 ¹³ / ₁₆	35 ¹ / ₂
d	14 ³ / ₈	14 ³ / ₈	20 ¹ / ₄
e	6 ³ / ₄	6 ³ / ₄	9 ¹ / ₈
f	7 ¹ / ₁₆	7 ¹ / ₁₆	8 ⁵ / ₈
g	5 ⁵ / ₈	5 ⁵ / ₈	7 ³ / ₄
h	2	2	4 ¹ / ₂
j	2	2	5 ¹ / ₂
k	7 ³ / ₈	9 ¹ / ₄	12
l	2 ¹ / ₁₆	2 ¹ / ₁₆	2 ⁵ / ₈
m	9 ³ / ₈	9 ³ / ₈	11
n	5 ¹ / ₄	5 ¹ / ₄	5 ¹ / ₂
p	1 ¹ / ₄	2	2 ¹ / ₂

*Dimensions are approximate, not for construction purposes.



CHS Controls AB
 Florettgatan 33
 SE-254 67 Helsingborg, Sweden
 Tel +46 42 38 61 00, Fax +46 42 38 61 29
 chs@chscontrols.se
 www.chscontrols.se

EPC Series Circuit Breakers and Enclosures

100/150A Frame, Thermal Magnetic,
120–240 VAC, 125–250 VDC

Cl. I, Div. 1 & 2, Groups C, D
Cl. II, Div. 1, Groups E, F, G
Cl. II, Div. 2, Groups F, G
Cl. III
NEMA 3, 4, 7CD, 9EFG

Explosionproof
Dust-Ignitionproof
Raintight
Wet Locations
Watertight

Ordering Information:

To order an enclosure complete with circuit breaker where there is a choice of manufacturer, insert the manufacturer's symbol in the designated position of the catalog number.

Enclosures only can be ordered. Select from listings.

Non-Interchangeable Trip

Circuit Breaker		Enclosure		Circuit Bkr. Amp Rating	Without Circuit Bkr. Cat. #	With Circuit Bkr. Cat. #	
Poles	Voltage Rating	Int. Dia.	Hub Size				
2	240VAC or 125-250VDC	7	1¼	15	EPC377	EPC377 ①15EB 2	
				20		EPC377 ①20EB 2	
				30		EPC377 ①30EB 2	
				40		EPC377 ①40EB 2	
				50		EPC377 ①50EB 2	
				70		EPC377 ①70EB 2	
				90		EPC377 ①90EB 2	
				100		EPC377 ①100EB 2	
				70		EPC387	EPC387 ① 70EB 2
				90			EPC387 ① 90EB 2
	100	EPC387 ① 100EB 2					
	3	240VAC*	7	1¼	15	EPC377	EPC377 ①15EB 3
					20		EPC377 ①20EB 3
					30		EPC377 ①30EB 3
40					EPC377 ①40EB 3		
50					EPC377 ①50EB 3		
70					EPC377 ①70EB 3		
90					EPC377 ①99EB 3		
100					EPC377 ①100EB 3		
70					EPC387		EPC387 ① 70EB 3
90							EPC387 ① 90EB 3
100	EPC387 ① 100EB 3						

*Square D 240VAC/125–250VDC

① Circuit Breakers

Manufacturer	Frame	Symbol
General Electric	TEB	TT
Square D	FAL	DT
Cutler-Hammer	ED	WT



CHS Controls AB
 Florettgatan 33
 SE-254 67 Helsingborg, Sweden
 Tel +46 42 38 61 00, Fax +46 42 38 61 29
chs@chscontrols.se
www.chscontrols.se

EPC Series Circuit Breakers and Enclosures

100/150A Frame, Thermal Magnetic,
480-600 VAC, 250 VDC

Cl. I, Div. 1 & 2, Groups C, D
Cl. II, Div. 1, Groups E, F, G
Cl. II, Div. 2, Groups F, G
Cl. III
NEMA 3, 4, 7CD, 9EFG

Explosionproof
Dust-Ignitionproof
Raintight
Wet Locations
Watertight

3C

Non-Interchangeable Trip

Circuit Breaker		Enclosure		Circuit Bkr. Amp Rating	Without Circuit Bkr. Cat. #	With Circuit Bkr. Cat. #
Poles	Voltage Rating	Int. Dia.	Hub Size			
2	480VAC or 250VDC	7	1¼	15	EPC377	EPC377 ①15EHD 2
				20		EPC377 ①20EHD 2
				30		EPC377 ①30EHD 2
				40		EPC377 ①40EHD 2
				50		EPC377 ①50EHD 2
				70		EPC377 ①70EHD 2
		7W	2	90	EPC387	EPC377 ①90EHD 2
				100		EPC377 ①100EHD 2
				70		EPC387 ①70EHD 2
				90		EPC387 ①90EHD 2
				100		EPC387 ①100EHD 2
3	480VAC†	7	1¼	15	EPC377	EPC377 ①15EHD 3
				20		EPC377 ①20EHD 3
				30		EPC377 ①30EHD 3
				40		EPC377 ①40EHD 3
				50		EPC377 ①50EHD 3
				70		EPC377 ①70EHD 3
		7W	2	90	EPC387	EPC377 ①90EHD 3
				100		EPC377 ①100EHD 3
				70		EPC387 ①70EHD 3
				90		EPC387 ①90EHD 3
				100		EPC387 ①100EHD 3
2	600VAC or 250VDC	7	1¼	15	EPC377	EPC377 ②15FDB 2
				20		EPC377 ②20FDB 2
				30		EPC377 ②30FDB 2
				40		EPC377 ②40FDB 2
				50		EPC377 ②50FDB 2
				70		EPC377 ②70FDB 2
		7W	2	90	EPC387	EPC377 ②90FDB 2
				100		EPC377 ②100FDB 2
				70		EPC387 ②70FDB 2
				90		EPC387 ②90FDB 2
				100		EPC387 ②100FDB 2
				110*		EPC387 ②110FDB 2
125*	EPC387 ②125FDB 2					
150*	EPC387 ②150FDB 2					
3	600VAC§	7	1¼	15	EPC377	EPC377 ②15FDB 3
				20		EPC377 ②20FDB 3
				30		EPC377 ②30FDB 3
				40		EPC377 ②40FDB 3
				50		EPC377 ②50FDB 3
				70		EPC377 ②70FDB 3
		7W	2	90	EPC387	EPC377 ②90FDB 3
				100		EPC377 ②100FDB 3
				70		EPC387 ②70FDB 3
				90		EPC387 ②90FDB 3
				100		EPC387 ②100FDB 3
				100*		EPC387 ②110FDB 3
125*	EPC387 ②125FDB 3					
150*	EPC387 ②150FDB 3					

① Circuit Breakers

Manufacturer	Frame	Symbol
General Electric	TED	TT
Square D	FAL	DT
Cutler-Hammer	EHD	WT

② Circuit Breakers

Manufacturer	Frame	Symbol
General Electric	TED	TT
Square D	FAL	DT
Cutler-Hammer	FD, FDB	WT

*Square D FAL Frame, 100A Max.

† Square D 480VAC/250VDC

§ Square D 600VAC/250VDC



CHS Controls AB
 Florettgatan 33
 SE-254 67 Helsingborg, Sweden
 Tel +46 42 38 61 00, Fax +46 42 38 61 29
 chs@chscontrols.se
 www.chscontrols.se

3C EPC Series Circuit Breakers and Enclosures

225/250A Frame, Thermal Magnetic, 600 VAC, 250 VDC

Cl. I, Div. 1 & 2, Groups C, D
 Cl. II, Div. 1, Groups E, F, G
 Cl. II, Div. 2, Groups F, G
 Cl. III
 NEMA 3, 4, 7CD, 9EFG

Explosionproof
 Dust-Ignitionproof
 Raintight
 Wet Locations
 Watertight

Non-Interchangeable Trip

Circuit Breaker		Enclosure		Circuit Bkr. Amp Rating	Without Circuit Bkr. Cat. #	With Circuit Bkr. Cat. #
Poles	Voltage Rating	Int. Dia.	Hub Size			
2	600VAC or 250VDC	11	2 1/2	125	EPC317	EPC317 ①125JB 2
				150		EPC317 ①150JB 2
				175		EPC317 ①175JB 2
				200		EPC317 ①200JB 2
				225		EPC317 ①225JB 2
3	600VAC	11	2 1/2	250*	EPC317	EPC317 ①250JB 2
				125		EPC317 ①125JB 3
				150		EPC317 ①150JB 3
				175		EPC317 ①175JB 3
				200		EPC317 ①200JB 3
				225		EPC317 ①225JB 3
				250*		EPC317 ①250JB 3

① Circuit Breakers

Manufacturer	Frame	Symbol
Cutler-Hammer	JDB	WT
General Electric	TFJ	TT
Square D	KAL	DT

*General Electric TFJ Frame, 225A Max.

3C



CHS Controls AB
 Florettgatan 33
 SE-254 67 Helsingborg, Sweden
 Tel +46 42 38 61 00, Fax +46 42 38 61 29
 chs@chscontrols.se
 www.chscontrols.se

FLB Series Circuit Breakers and Enclosures

Cl. I, Div. 1 & 2, Groups C, D
 Cl. II, Div. 1, Groups E, F, G
 Cl. II, Div. 2, Groups F, G
 Cl. III
 NEMA 3, 4, 7CD, 9EFG

Explosionproof
 Dust-Ignitionproof
 Raintight
 Wet Locations
 Watertight

3C

Applications:

FLB circuit breakers and enclosures are used:

- For service entrance, feeder or branch circuit protection for lighting, heating, appliance and motor circuits
- In areas made hazardous due to the presence of flammable vapors, gases or combustible dusts
- In damp, wet or corrosive locations
- Indoors or outdoors at petroleum refineries, chemical and petrochemical plants and other process industry facilities where similar hazards exist
- To provide disconnect means, short circuit protection and thermal time delay overload protection

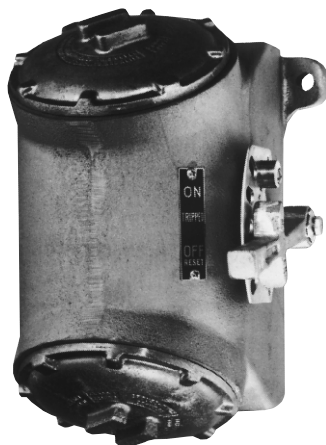

Features:

- Semi-cylindrical body shape for maximum strength at lowest practical weight
- Round threaded covers at each end, set at an angle to provide ready access to interior for ease of wiring
- Breaker is operated by an external handle which can be padlocked in either "ON" or "OFF" positions. Breaker is trip-free of the handle and will open under short circuit or overload even if the handle is locked in the "ON" position
- Bodies have vertical through feed conduit hubs of sizes given in the listings

Certifications and Compliances:

- NEC/CEC
 - Class I, Division 1 & 2, Groups C, D
 - Class II, Division 1, Groups E, F, G
 - Class II, Division 2, Groups F, G
 - Class III
- NEMA/EEMAC: 3, 4, 7CD, 9EFG
- UL Standard: 698
- CSA Standard: C22.2 No. 30

Standard Materials:

- Bodies, covers and operating handles – copper-free aluminum
- Operating shafts – stainless steel
- Interior parts – sheet steel

Standard Finishes:

- Copper-free aluminum – natural
- Stainless steel – natural
- Sheet steel – zinc electroplate with chromate finish

Electrical Rating Ranges:

- 100 and 225 ampere frame sizes

Options:

The following special options are available from factory by adding suffix to Cat. #:

Description	Suffix
2 lugs for neutral connections (50, 100 and 225 amp.)	S146
Ground neutral stud with 3 connectors (50, 100 and 225 amp.)	S168
Standard Breather (Class I, Groups C, D; Class II, Groups E, F, G; Class III)	S219
Standard Drain (Class I, Groups C, D; Class II, Groups E, F, G; Class III)	S198
Standard Breather and Drain (Class I, Groups C, D; Class II, Groups E, F, G; Class III)	S198V
Universal Breather – Drain (Class I, Groups C, D; Class II, Groups F, G)	S454*
(2) Universal Breather – Drains (Class I, Groups C, D; Class II, Groups F, G)	S454V*
Specify Auxiliary Switch†	
1A/1B (1P2T)	S784
2A/2B (2P2T)	S785

Dimensions

In Inches§:

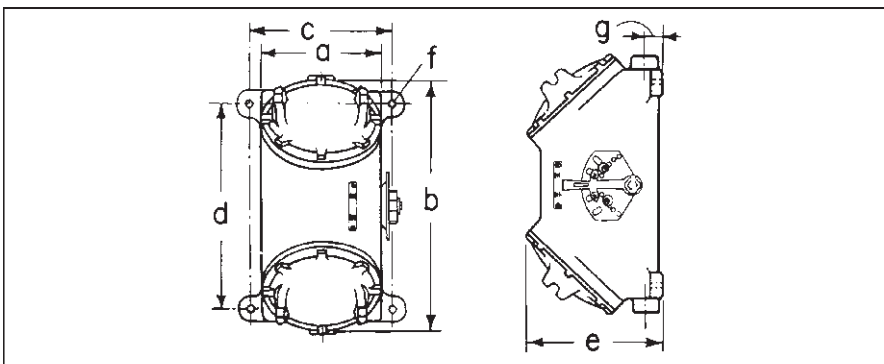

Cat. #	a	b	c	d	e	f	g
†FLB140, 220, 221	5¼	10¼	6¼	7¼	7	7/16	1⅞
FLB115, 141, 147, 148, 171, 172, 173, 175, 222, 361, 116, 142, 149, 174, 177, 223, 362	7½	13⅜	8½	9¾	9⅞	7/16	1¾
FLB224, 225, 264, 265, 267, 346	13¾	22½	16¼	9⅞	15½	21/32	27/16

*Not suitable for NEMA 4/EEMAC.

†With two mounting feet, one at upper right and one at lower left.

‡Application is limited by circuit breaker design – Consult Factory.

§Dimensions are approximate, not for construction purposes.



CHS Controls AB

Tel +46 42 38 61 00, Fax +46 42 38 61 29
 chs@chscontrols.se www.chscontrols.se

3C FLB Series Circuit Breakers and Enclosures

**100A Frame, Thermal Magnetic,
120 VAC/125 VDC, 240 VAC/250 VDC**

Cl. I, Div. 1 & 2, Groups C, D
Cl. II, Div. 1, Groups E, F, G
Cl. II, Div. 2, Groups F, G
Cl. III
NEMA 3, 4, 7CD, 9EFG

Explosionproof
Dust-Ignitionproof
Raintight
Wet Locations
Watertight

Ordering Information:

To order an enclosure complete with circuit breaker where there is a choice of manufacturer, insert the manufacturer's symbol in the designated position of the catalog number.

Enclosures only can be ordered. Select from listings.

100 Ampere Frame Size with Non-Interchangeable Trip 240VAC Max.

Circuit Breaker		Enclosure			
Poles	Voltage Rating	Hub Size	Circuit Bkr. Amp Rating	Without Circuit Bkr. Cat. #	With Circuit Bkr. General Electric "TEB" Cat. #
1	120VAC or 125VDC	¾	15	FLB220	FLB220 TT15 1
			20		FLB220 TT20 1
			30		FLB220 TT30 1
			40		FLB220 TT40 1
			50		FLB220 TT50 1
2	240VAC or 125-250VDC	1	15	FLB221	FLB221 TT15 2
			20		FLB221 TT20 2
			30		FLB221 TT30 2
			40		FLB221 TT40 2
		50	FLB221 TT50 2		
		1½	70	FLB223	FLB223 TT70 2
			90		FLB223 TT90 2
100	FLB223 TT100 2				
3	240VAC	1¼	15	FLB222	FLB222 TT15 3
			20		FLB222 TT20 3
			30		FLB222 TT30 3
			40		FLB222 TT40 3
		50	FLB222 TT50 3		
		1½	70	FLB223	FLB223 TT70 3
			90		FLB223 TT90 3
			100		FLB223 TT100 3

3C



CHS Controls AB
 Florettgatan 33
 SE-254 67 Helsingborg, Sweden
 Tel +46 42 38 61 00, Fax +46 42 38 61 29
 chs@chscontrols.se
 www.chscontrols.se

FLB Series Circuit Breakers and Enclosures

**100A Frame, Thermal Magnetic,
120–480 VAC, 125–250 VDC**

Cl. I, Div. 1 & 2, Groups C, D
Cl. II, Div. 1, Groups E, F, G
Cl. II, Div. 2, Groups F, G
Cl. III
NEMA 3, 4, 7CD, 9EFG

Explosionproof
Dust-Ignitionproof
Raintight
Wet Locations
Watertight

3C

100 Ampere Frame Size with Non-Interchangeable Trip 240VAC Max.

Circuit Breaker		Enclosure		Without Circuit Bkr. Cat. #	With Circuit Bkr. Square D "FAL" Cat. #
Poles	Voltage Rating	Hub Size	Circuit Bkr. Amp Rating		
1	120VAC or 125VDC	3/4	15	FLB171	FLB171 DT15 1 FLB171 DT20 1 FLB171 DT30 1 FLB171 DT40 1 FLB171 DT50 1
			20		
			30		
			40		
2	240VAC or 125–250VDC	1	50	FLB172	FLB172 DT15 2 FLB172 DT20 2 FLB172 DT30 2 FLB172 DT40 2 FLB172 DT50 2
			70		
			90		
			100		
		1 1/2	FLB174	FLB174 DT70 2 FLB174 DT90 2 FLB174 DT100 2	
3	240VAC or 125–250VDC	1 1/4	15	FLB173	FLB173 DT15 3 FLB173 DT20 3 FLB173 DT30 3 FLB173 DT40 3 FLB173 DT50 3
			20		
			30		
			40		
		1 1/2	FLB174	FLB174 DT70 3 FLB174 DT90 3 FLB174 DT100 3	
					50
			70		
			90		
			100		

3C

100 Ampere Frame Size with Non-Interchangeable Trip 480VAC Max.

Circuit Breaker		Enclosure		Without Circuit Bkr. Cat. #	With Circuit Bkr. Cutler-Hammer "EHD" Cat. #	With Circuit Breaker General Electric "TED" Cat. #
Poles	Voltage Rating	Hub Size	Circuit Bkr. Amp Rating			
2	480VAC or 250VDC	1	15	FLB140	FLB140 WT15 2 FLB140 WT20 2 FLB140 WT30 2 FLB140 WT40 2 FLB140 WT50 2	FLB140 TT15 2 FLB140 TT20 2 FLB140 TT30 2 FLB140 TT40 2 FLB140 TT50 2
			20			
			30			
			40			
			50			
3	480VAC	1 1/4	70	FLB141	FLB141 WT15 3 FLB141 WT20 3 FLB141 WT30 3 FLB141 WT40 3 FLB141 WT50 3	FLB141 TT15 3 FLB141 TT20 3 FLB141 TT30 3 FLB141 TT40 3 FLB141 TT50 3
			90			
			100			
			1 1/2			
					70	
			90			
			100			



CHS Controls AB
 Florettgatan 33
 SE-254 67 Helsingborg, Sweden
 Tel +46 42 38 61 00, Fax +46 42 38 61 29
 chs@chscontrols.se
 www.chscontrols.se

3C

FLB Series Circuit Breakers and Enclosures

**100A Frame, Thermal Magnetic,
480 VAC, 250 VDC**

Cl. I, Div. 1 & 2, Groups C, D
Cl. II, Div. 1, Groups E, F, G
Cl. II, Div. 2, Groups F, G
Cl. III
NEMA 3, 4, 7CD, 9EFG

Explosionproof
Dust-Ignitionproof
Raintight
Wet Locations
Watertight

100 Ampere Frame Size with Non-Interchangeable Trip 480VAC Max.

Circuit Breaker		Enclosure					
Poles	Voltage Rating	Hub Size	Circuit Bkr. Amp Rating	Without Circuit Bkr. Cat. #	With Circuit Bkr. Square D "FAL" Cat. #		
2	480VAC or 250VDC	1¼	15	FLB147	FLB147 DT15 2		
			20		FLB147 DT20 2		
			30		FLB147 DT30 2		
			40		FLB147 DT40 2		
			50		FLB147 DT50 2		
		1½	70	FLB149	FLB149 DT70 2		
			90		FLB149 DT90 2		
			100		FLB149 DT100 2		
			<hr/>				
			3		480VAC or 250VDC	1¼	15
20	FLB148 DT20 3						
30	FLB148 DT30 3						
40	FLB148 DT40 3						
50	FLB148 DT50 3						
1½	70	FLB149		FLB149 DT70 3			
	90			FLB149 DT90 3			
	100			FLB149 DT100 3			

3C



CHS Controls AB
 Florettgatan 33
 SE-254 67 Helsingborg, Sweden
 Tel +46 42 38 61 00, Fax +46 42 38 61 29
 chs@chscontrols.se
 www.chscontrols.se

FLB Series Circuit Breakers and Enclosures

100A Frame, Thermal Magnetic, 600 VAC, 250 VDC

Cl. I, Div. 1 & 2, Groups C, D
Cl. II, Div. 1, Groups E, F, G
Cl. II, Div. 2, Groups F, G
Cl. III
NEMA 3, 4, 7CD, 9EFG

Explosionproof
Dust-Ignitionproof
Raintight
Wet Locations
Watertight

3C

100 Ampere Frame Size with Non-Interchangeable Trip 600VAC Max.

Circuit Breaker		Enclosure				
Poles	Voltage Rating	Hub Size	Circuit Bkr. Amp Rating	Without Circuit Bkr. Cat. #	With Circuit Bkr. Cutler-Hammer "FDB" Cat. #	
2	600VAC or 250VDC	1¼	15	FLB115	FLB115 WT15 2	
			20		FLB115 WT20 2	
			30		FLB115 WT30 2	
			40		FLB115 WT40 2	
			50		FLB115 WT50 2	
3	600VAC	1½	70	FLB116	FLB116 WT70 2	
			90		FLB116 WT90 2	
			100		FLB116 WT100 2	
			15		FLB115	FLB115 WT15 3
			20			FLB115 WT20 3
30	FLB115 WT30 3					
40	FLB115 WT40 3					
50	FLB115 WT50 3					
3	600VAC	1½	70	FLB116	FLB116 WT70 3	
			90		FLB116 WT90 3	
			100		FLB116 WT100 3	

Circuit Breaker		Enclosure			
Poles	Voltage Rating	Hub Size	Circuit Bkr. Amp Rating	Without Circuit Bkr. Cat. #	With Circuit Bkr. General Electric "TED" Cat. #
3	600VAC	1¼	15	FLB361	FLB361 TT15 3
			20		FLB361 TT20 3
			30		FLB361 TT30 3
			40		FLB361 TT40 3
			50		FLB361 TT50 3
3	600VAC	1½	70	FLB362	FLB362 TT70 3
			90		FLB362 TT90 3
			100		FLB362 TT100 3

Circuit Breaker		Enclosure				
Poles	Voltage Rating	Hub Size	Circuit Bkr. Amp Rating	Without Circuit Bkr. Cat. #	With Circuit Bkr. Square D "FAL" Cat. #	
2	600VAC or 250VDC	1¼	15	FLB175	FLB175 DT15 2	
			20		FLB175 DT20 2	
			30		FLB175 DT30 2	
			40		FLB175 DT40 2	
			50		FLB175 DT50 2	
3	600VAC or 250VDC	1½	70	FLB177	FLB177 DT70 2	
			90		FLB177 DT90 2	
			100		FLB177 DT100 2	
			15		FLB175	FLB175 DT15 3
			20			FLB175 DT20 3
30	FLB175 DT30 3					
40	FLB175 DT40 3					
50	FLB175 DT50 3					
3	600VAC or 250VDC	1½	70	FLB177	FLB177 DT70 3	
			90		FLB177 DT90 3	
			100		FLB177 DT100 3	



CHS Controls AB
 Florettgatan 33
 SE-254 67 Helsingborg, Sweden
 Tel +46 42 38 61 00, Fax +46 42 38 61 29
 chs@chscontrols.se
 www.chscontrols.se

FLB Series Circuit Breakers and Enclosures

225A Frame, Thermal Magnetic,
600 VAC, 250 VDC

Cl. I, Div. 1 & 2, Groups C, D
Cl. II, Div. 1, Groups E, F, G
Cl. II, Div. 2, Groups F, G
Cl. III
NEMA 3, 4, 7CD, 9EFG

Explosionproof
Dust-Ignitionproof
Raintight
Wet Locations
Watertight

100 Ampere Frame Size with Non-Interchangeable Trip 600VAC Max.

Circuit Breaker		Enclosure				
Poles	Voltage Rating	Hub Size	Circuit Bkr. Amp Rating	Without Circuit Bkr. Cat. #	With Circuit Bkr. Cutler-Hammer "JDB"† Cat. #	
2	600VAC or 250VDC	2½	125	FLB264		FLB264 WT125 2
			150			FLB264 WT150 2
			175			FLB264 WT175 2
			200			FLB264 WT200 2
			225			FLB264 WT225 2
3	600VAC	2½	125	FLB264		FLB264 WT125 3
			150			FLB264 WT150 3
			175			FLB264 WT175 3
			200			FLB264 WT200 3
			225			FLB264 WT225 3
Poles	Voltage Rating	Hub Size	Circuit Bkr. Amp Rating	Without Circuit Bkr. Cat. #	With Circuit Bkr. General Electric "TFJ" Cat. #	With Circuit Bkr. Square D "KAL" Cat. #
2	600VAC or 250VDC	2½	125	FLB346		FLB346 DT125 2
			150			FLB346 DT150 2
			175			FLB346 DT175 2
			200			FLB346 DT200 2
			225			FLB346 DT225 2
3	600VAC	2½	125	FLB224 or FLB346		FLB224 TT125 3
			150			FLB224 TT150 3
			175			FLB224 TT175 3
			200			FLB224 TT200 3
			225			FLB224 TT225 3
					FLB346 DT125 3	FLB346 DT150 3
					FLB346 DT175 3	FLB346 DT200 3
					FLB346 DT225 3	

100 Ampere Frame Size with Interchangeable Trip 600VAC Max.

Circuit Breaker		Enclosure				
Poles	Voltage Rating	Hub Size	Circuit Bkr. Amp Rating	Without Circuit Bkr. Cat. #	With Circuit Bkr. Cutler-Hammer "JD"* Cat. #	With Circuit Bkr. General Electric "TFK" Cat. #
2	600VAC or 250VDC	3	125	FLB267		FLB267 WT125 2
			150			FLB267 WT150 2
			175			FLB267 WT175 2
			200			FLB267 WT200 2
			225			FLB267 WT225 2
3	600VAC	3	125	FLB267 or FLB225		FLB267 WT125 3
			150			FLB267 WT150 3
			175			FLB267 WT175 3
			200			FLB267 WT200 3
			225			FLB267 WT225 3
					FLB225 TT125 3	FLB225 TT150 3
					FLB225 TT175 3	FLB225 TT200 3
					FLB225 TT225 3	

*Formerly "KB"
†Formerly "JB"



CHS Controls AB
 Florettgatan 33
 SE-254 67 Helsingborg, Sweden
 Tel +46 42 38 61 00, Fax +46 42 38 61 29
chs@chscontrols.se
www.chscontrols.se

EFD and EFDC Series Circuit Breakers and Enclosures

120VAC, Single Pole

Cl. I, Div. 1 & 2, Groups B*, C, D
 Cl. II, Div. 1, Groups E, F, G
 Cl. II, Div. 2, Groups F, G
 Cl. III
 NEMA 3, 7B*CD, 9EFG, 12

Explosionproof
 Dust-Ignitionproof
 Raintight
 Wet Locations

3C

Applications:

EFD circuit breakers and enclosures are used:

- For branch circuit protection for lighting, appliance, and motor circuits
- In areas made hazardous due to the presence of flammable vapors, gases or combustible dusts
- In corrosive locations
- For installation at petroleum refineries, chemical and petrochemical plants and other process industry facilities where similar hazards exist
- To provide disconnect means, short circuit protection and thermal time delay overload protection

Features:

- Small, compact enclosures with accurately ground, wide flange on both body and cover for flametight joint
- Dead-end (EFD) or through feed (EFDC) hubs $\frac{3}{4}$ " to 1" sizes
- Breaker mounted on cover and back wired for ease of installation
- Breaker can be padlocked in "ON" or "OFF" positions with trip-free handle mechanism

Certifications and Compliances:

- NEC:
 - Class I, Division 1 & 2, Groups B*, C, D
 - Class II, Division 1, Groups E, F, G
 - Class II, Division 2, Groups F, G
 - Class III
- NEMA 3, 7B*CD, 9EFG, 12

Standard Materials:

- Bodies and covers – *Feraloy*[®] iron alloy
- Operating handles – type 6 / 6 nylon
- Operating shafts – stainless steel

Standard Finishes:

- *Feraloy* – electrogalvanized and aluminum acrylic paint
- Type 6 / 6 nylon – black
- Stainless steel – natural

Dimensions

In Inches†:

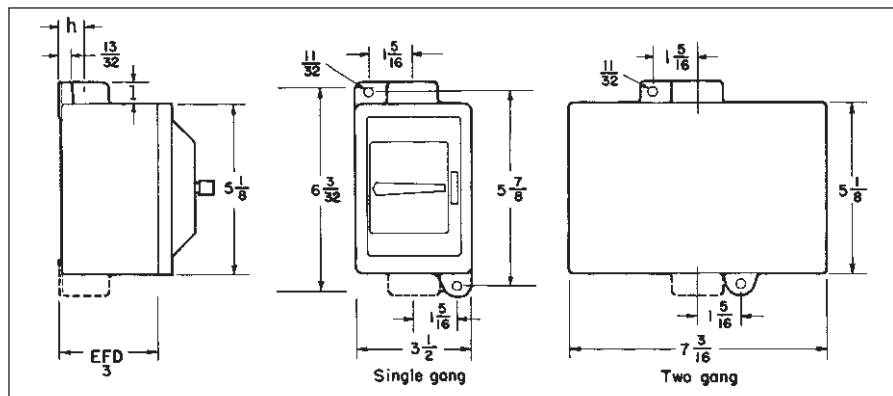

EFD dead end



EFDC through feed

Electrical Ratings:

- Single pole – 120 / 240 VAC max.
- Trip ratings – 15, 20 and 30 amp.

Options:

Description
 For use in Group B hazardous areas*

Suffix
 GB

Ordering Information With Square D Type "QOU" Circuit Breakers

Hub Size in.	15 Amp Cat. #	20 Amp Cat. #	30 Amp Cat. #
EFD Single Gang (Dead End)			
$\frac{3}{4}$	EFD21104	EFD21105	EFD21106
1	EFD31104	EFD31105	EFD31106
EFDC Single Gang (Through Feed)			
$\frac{3}{4}$	EFDC21104	EFDC21105	EFDC21106
1	EFDC31104	EFDC31105	EFDC31106
EFD Two Gang (Dead End)			
$\frac{3}{4}$	EFD22104	EFD22105	EFD22106
1	EFD32104	EFD32105	EFD32106
EFDC Two Gang (Through Feed)			
$\frac{3}{4}$	EFDC22104	EFDC22105	EFDC22106
1	EFDC32104	EFDC32105	EFDC32106

Hub Size	Dim. "h"	Dim. "l"
$\frac{3}{4}$	$\frac{7}{8}$	$\frac{13}{16}$
1	1	$\frac{15}{16}$



CHS Controls AB
 Florettgatan 33
 SE-254 67 Helsingborg, Sweden
 Tel +46 42 38 61 00, Fax +46 42 38 61 29
 chs@chscontrols.se
 www.chscontrols.se

*Seals must be installed within $\frac{1}{2}$ " of each conduit opening, for Group B use.
 †Dimensions are approximate, not for construction purposes.

Applications:

- NCB circuit breakers are for use in conjunction with a variety of heating, lighting and power circuits to provide disconnect means and short circuit protection.

Features:

- Enclosures are made of *Krydon*[®], Cooper Crouse-Hinds' high impact strength fiberglass-reinforced polyester material having excellent corrosion resistance and stability to heat
- Unitized, strong and durable enclosure construction provides longer service life for equipment
- Enclosure has hinged access door which opens 160° for easy wiring and maintenance. Three screws for door frame are hidden behind access door
- Access door may be padlocked to prevent unauthorized access

Certifications and Compliances:

- NEMA: 3, 4X and 12
- CSA Standard: C22.2 No. 94
- UL Standard: 489

Electrical Rating Ranges:

- 100, 150, 225, 250 and 400 amp frames

Options:

- Description**
- Insulated, groundable type terminal block for grounded or ungrounded neutral can be supplied
 - Hubs (see "Note on Hubs") – see page 646
 - Grounding plate or bushing – see page 646

Suffix

S618



Circuit breaker enclosure with built-in *Krydon* material handle

Ordering Information

To order an enclosure complete with circuit breaker, insert the manufacturer's symbol in the designated position of the catalog number. Enclosures only can be ordered. Select from listings.

Circuit Breaker			Enclosure	
Poles	Voltage Rating	Amps	With Circuit Breaker Cat. #	Without Circuit Breaker Cat. #
100A Frame (Non-Interchangeable Trip)				
2	240 VAC/ 250 VDC	15	NCB1018F ①15EB 22	NCB1018F
		20	NCB1018F ①20EB 22	
		25	NCB1018F ①25EB 22	
		30	NCB1018F ①30EB 22	
		35	NCB1018F ①35EB 22	
		40	NCB1018F ①40EB 22	
		50	NCB1018F ①50EB 22	
		60	NCB1018F ①60EB 22	
		70	NCB1018F ①70EB 22	
		80	NCB1018F ①80EB 22	
		90	NCB1018F ①90EB 22	
100	NCB1018F ①100EB 22			
2	480 VAC/ 250 VDC	15	NCB1018F ①15EHB 24	NCB1018F
		20	NCB1018F ①20EHB 24	
		25	NCB1018F ①25EHB 24	
		30	NCB1018F ①30EHB 24	
		35	NCB1018F ①35EHB 24	
		40	NCB1018F ①40EHB 24	
		50	NCB1018F ①50EHB 24	
		60	NCB1018F ①60EHB 24	
		70	NCB1018F ①70EHB 24	
		80	NCB1018F ①80EHB 24	
		90	NCB1018F ①90EHB 24	
100	NCB1018F ①100EHB 24			

NCB1018F



CHS Controls AB
Tel +46 42 38 61 00, Fax +46 42 38 61 29
chs@chscontrols.se www.chscontrols.se

①Circuit Breakers:

Frames

Manufacturer	Symbol	100/ 150A		225/ 250A		400A
		240V	480V	600V	600V	
General Electric	TT	TEB	TED†	TED†	TFJ	
Square D	DT	FAL†	FAL†	FAL†	KAL	LAL
Cutler-Hammer			EHB,	FB,	JB,	
	WT	EB	EHD	FDB	JDB	

†Specify voltage.

NOTE ON HUBS: The following number and sizes of hubs (not mounted) are included when circuit breakers are ordered complete. If enclosures only are ordered, hubs must be ordered separately (see "Options")

Circuit Breaker Frame	Ampere Rating	Number Included	Hub Size
EB, EHD*, FDB‡	15–50	2	1¼
EB, EHD*, FDB‡	60–100	2	2
JDB■	110–225	2	2½
KDB§	250–400	2	3

*Formerly EHB.
‡Formerly FB.
§Formerly LB.
■Formerly JB.

NCB Series Circuit Breakers and Enclosures

600VAC, 250VDC Heavy Duty

Corrosion-Resistant
Dust-tight
Watertight
Weatherproof
NEMA 3, 4X, 12

3C

Circuit Breaker		Enclosure		
Poles	Voltage Rating	Amps	With Circuit Breaker Cat. #	Without Circuit Breaker Cat. #
100/150A Frame (Non-Interchangeable Trip) – continued				
2†	600 VAC/ 250 VDC	15	NCB1018F ①15FB 26	NCB1018F
		20	NCB1018F ①20FB 26	
		25	NCB1018F ①25FB 26	
		30	NCB1018F ①30FB 26	
		35	NCB1018F ①35FB 26	
		40	NCB1018F ①40FB 26	
		50	NCB1018F ①50FB 26	
		70	NCB1018F ①70FB 26	
		80	NCB1018F ①80FB 26	
		90	NCB1018F ①90FB 26	
100	NCB1018F ①100FB 26			
3	240 VDC	15	NCB1018F ①15EB 32	NCB1018F
		20	NCB1018F ①20EB 32	
		25	NCB1018F ①25EB 32	
		30	NCB1018F ①30EB 32	
		35	NCB1018F ①35EB 32	
		40	NCB1018F ①40EB 32	
		50	NCB1018F ①50EB 32	
		70	NCB1018F ①70EB 32	
		80	NCB1018F ①80EB 32	
		90	NCB1018F ①90EB 32	
100	NCB1018F ①100EB 32			
3	480 VAC	15	NCB1018F ①15EHB 34	NCB1018F
		20	NCB1018F ①20EHB 34	
		25	NCB1018F ①25EHB 34	
		30	NCB1018F ①30EHB 34	
		35	NCB1018F ①35EHB 34	
		40	NCB1018F ①40EHB 34	
		50	NCB1018F ①50EHB 34	
		70	NCB1018F ①70EHB 34	
		80	NCB1018F ①80EHB 34	
		90	NCB1018F ①90EHB 34	
100	NCB1018F ①100EHB 34			
3	600 VAC	15	NCB1018F ①15FB 36	NCB1018F
		20	NCB1018F ①20FB 36	
		25	NCB1018F ①25FB 36	
		30	NCB1018F ①30FB 36	
		35	NCB1018F ①35FB 36	
		40	NCB1018F ①40FB 36	
		50	NCB1018F ①50FB 36	
		70	NCB1018F ①70FB 36	
		80	NCB1018F ①80FB 36	
		90	NCB1018F ①90FB 36	
100	NCB1018F ①100FB 36			

Circuit Breaker		Enclosure		
Poles	Voltage Rating	Amps	With Circuit Breaker Cat. #	Without Circuit Breaker Cat. #
225/50A Frame (Non-Interchangeable Trip)§				
2	600 VAC/ 250 VDC	110	NCB1024F ①110JB 26	NCB1024F
		125	NCB1024F ①125JB 26	
		150	NCB1024F ①150JB 26	
		175	NCB1024F ①175JB 26	
		200	NCB1024F ①200JB 26	
		225	NCB1024F ①225JB 26	
3	600 VDC	110	NCB1024F ①110JB 36	NCB1024F
		125	NCB1024F ①125JB 36	
		150	NCB1024F ①150JB 36	
		175	NCB1024F ①175JB 36	
		200	NCB1024F ①200JB 36	
		225	NCB1024F ①225JB 36	
400A Frame (Interchangeable Trip)*				
2	600 VAC/ 250 VDC	250	NCB1426F ①250LB 26	NCB1426F
		300	NCB1426F ①300LB 26	
		350	NCB1426F ①350LB 26	
		400	NCB1426F ①400LB 26	
3	600 VAC	250	NCB1426F ①250LB 36	NCB1426F
		300	NCB1426F ①300LB 36	
		350	NCB1426F ①350LB 36	
		400	NCB1426F ①400LB 36	

①Circuit Breakers:

Manufacturer	Symbol	Frames				
		100/ 150A 240V	480V	600V	225/ 250A 600V	400A 600V
General Electric	TT	TEB	TED†	TED†	TFJ	
Square D	DT	FAL†	FAL†	FAL†	KAL	LAL
Cutler-Hammer	WT	EB	EHB, EHD	FB, FDB	JB, JDB	

Note on Hubs: The following number and sizes of hubs (not mounted) are included when circuit breakers are ordered complete. If enclosures only are ordered, hubs must be ordered separately (see "Options").

Circuit Breaker Frame	Ampere Rating	Number Included	Hub Size
EB, EHD⊕, FDB▲	15–50	2	1¼
EB, EHD⊕, FDB▲	60–100	2	2
JDB■	110–225	2	2½

■ Formerly JB
⊕ Formerly EHB
▲ Formerly FB

†Specify voltage.

‡2-pole, 600 VAC/250 VDC for Square D circuit breakers only.

*For Square D circuit breakers only.

§Also available with interchangeable trip breakers. Specify on order.



CHS Controls AB
 Florettgatan 33
 SE-254 67 Helsingborg, Sweden
 Tel +46 42 38 61 00, Fax +46 42 38 61 29
 chs@chscontrols.se
 www.chscontrols.se

3C NCB Series Circuit Breakers and Enclosures

600VAC, 250VDC Heavy Duty

Corrosion-Resistant
Dust-tight
Watertight
Weatherproof
NEMA 3, 4X, 12

Dimensions In Inches*

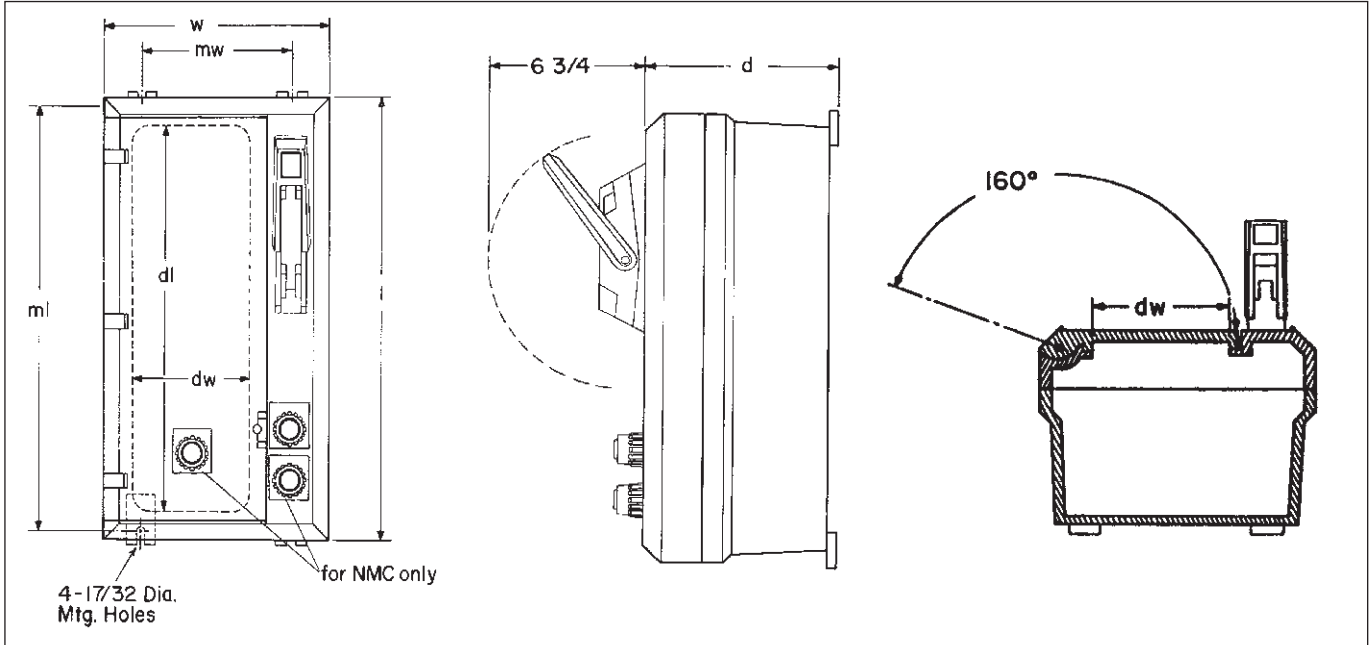

Cat. #	Outside Dimensions			Mounting Dimensions		Door Opening Dimensions	
	l	w	d	mw	ml	dl	dw
NCB1018	19 ¹³ / ₃₂	11 ¹³ / ₃₂	8 ²³ / ₃₂	7 ¹ / ₈	19 ³ / ₈	16 ⁷ / ₈	5 ¹¹ / ₁₆
NCB1024	25 ¹³ / ₃₂	11 ¹³ / ₃₂	8 ²³ / ₃₂	7 ¹ / ₈	25 ³ / ₈	22 ⁷ / ₈	5 ¹¹ / ₁₆
NCB1426	27 ¹³ / ₃₂	15 ¹³ / ₃₂	9 ²³ / ₃₂	11 ¹ / ₈	27 ¹ / ₄	23 ¹¹ / ₁₆	9 ¹¹ / ₁₆

*Dimensions are approximate, not to be used for construction purposes.



CHS Controls AB

Florettgatan 33
SE-254 67 Helsingborg, Sweden
Tel +46 42 38 61 00, Fax +46 42 38 61 29
chs@chscontrols.se
www.chscontrols.se

Description	Page No.
Application/Selection	see pages 498–499
EDS / EFS Series Control Stations	
FlexStation™ Control Station Components	see page 500
EDSCM Modular Series Bodies	see page 505
DSD Cover and Device Sub-assemblies	see page 507
DSD-SR HP Rated Selector Switch	see page 510
Fully Assembled EDS and EFS Control Stations	
EDS Pushbutton Stations	see page 513
EFS Pilot Light Stations	see pages 516–517
EDS Combination Pushbutton and Pilot Light Stations	see page 518
EDS Selector Switches	see page 519
EFS Selector Switches	see page 520
EDS Snap Switches	see page 521
EDS Manual Motor Starting Switches	see pages 522–523
EFS Fire Alarm Station	see page 524
EDS / EFS Control Stations Sub-assembly Reference Guide	see page 525
MC / MCC Pushbutton, Selector Switch, and Pilot Light Stations	see page 527
N2S / N2SC Control Stations	see page 530
N2SU / N2SCU Control Stations	see page 537
N2FA / N2FAC Fire Alarm Control Stations	see page 541
GHG43 Control Stations	see page 542
OAC Pushbutton Stations and Selector Switches	see page 553
Control Station Covers	see page 556
Replacements for Pushbutton and Selector Switch Control Stations	see page 557



CHS Controls AB
 Florettgatan 33
 SE-254 67 Helsingborg, Sweden
 Tel +46 42 38 61 00, Fax +46 42 38 61 29
 chs@chscontrols.se
 www.chscontrols.se

Application and Selection Quick Selector Chart

Applications:

Control stations are used as a remote means of:

- Motor control
- Visual indication of equipment performance
- On-off control of circuits
- Circuit selection

Considerations for Selection:

- The environment of the control station location and requirements for construction in terms of NEC/CEC compliances and NEMA/EEMAC type
- Function to be performed
- Desirability of factory sealing as compared to field sealing
- Factory sealing has distinct advantages:
 - Less installation problems
 - Less time consuming
 - Less change of error
 - Lower installed cost
 - Accommodates future changes to circuitry
 - Greater reliability
- The number of controls required, and the space available for installation. Where space is limited, panel or junction box mounting with many combinations are available
- See "Quick Selector Chart" for guidance

Options:

Many options are available on:

- Material and finishes where special atmospheric conditions prevail
- Special features for specific applications. See individual control station listings for available options

Quick Selector Chart

Control Station	NEC/CEC – Hazardous Area Compliance	NEMA/EEMAC Type	Function	Factory Sealed	No. of Devices or Units	Type of Mounting	Cover Style
MC, MCC		3, 4	Pushbutton Pilot light Selector switch		1-5*	Surface 1-5 gang	Gasketed
EDS, EDSC§	Cl. I, Div. 1, Groups C, D Cl. I, Div. 2, Groups B, C, D Cl. II, Div. 1, Groups E, F, G Cl. II, Div. 2, Groups F, G Cl. III	3, 7B (Div. 2) CD, 9EFG	Pilot light Pushbutton Selector switch	Pilot light Pushbutton Selector switch§	1-2*	Surface 1-2 gang	Ground joint
DSD Covers and Device Sub-assemblies	Cl. I, Div. 1 & 2, Groups B, C, D Cl. II, Div. 1, Groups E, F, G Cl. II, Div. 2, Groups F, G Cl. III	3, 7B, 9EFG	Pilot light Pushbutton Selector switch	Pilot light Pushbutton Selector switch	1	Surface 1 gang	Ground joint
DSD-SR	Cl. I, Div. 1 & 2, Groups C, D Cl. II, Div. 1, Groups E, F, G Cl. II, Div. 2, Groups F, G Cl. III	3, 5, 7CD, 9EFG, 12	Selector Switch		1	Surface 1 gang	Ground joint
EDSCM	Cl. I, Div. 1, Groups C, D Cl. I, Div. 2, Groups B, C, D Cl. II, Div. 1, Groups E, F, G Cl. II, Div. 2, Groups F, G Cl. III	3, 7CD, 9EFG	Pilot light Pushbutton Selector switch		1-15*	Surface 1-15 gang	Ground joint
EFSS§	Cl. I, Div. 1 & 2, Groups B, C, D Cl. II, Div. 1, Groups E, F, G Cl. II, Div. 2, Groups F, G Cl. III	3, 7BCD, 9EFG	Pilot light Pushbutton Selector switch	Pilot light§ Pushbutton Selector switch	1-2*	Surface 1 gang	Ground joint

*Number of devices per unit.

§Factory-sealed units.



CHS Controls AB
 Florettgatan 33
 SE-254 67 Helsingborg, Sweden
 Tel +46 42 38 61 00, Fax +46 42 38 61 29
 chs@chscontrols.se
 www.chscontrols.se

Application and Selection Quick Selector Chart

Quick Selector Chart (continued)

Control Station	NEC/CEC – Hazardous Area Compliances	NEMA/EEMAC Type	Function	Factory Sealed	No. of Devices or Units	Type of Mounting	Cover Style
FlexStation	Cl. I, Div. 1, Groups C, D Cl. I, Div. 2, Groups B, C, D Cl. II, Div. 1, Groups E, F, G Cl. II, Div. 2, Groups F, G Cl. III	3, 7B (Div. 2) CD, 9EFG	Pilot light Pushbutton	Pilot light Pushbutton	1-2-3	Surface 1-2 gang	Ground joint
GHG43	Cl. I, Div. 2, Groups A, B, C, D Cl. I, Zones 1 and 2, (A)Ex de IIB + H2, T6 Cl. II, Div. 1, Groups E, F, G PTB ATEX Certified 3117 CENELEC EEx de IIC, T6, Zones 1 and 2 Eex de IIC, T6 Zones 21 and 22	4X, IP66	Pushbutton Signal Lamp Potentiometer Ammeter Selector Switch Terminal Blocks		1-4*	Surface 1 gang	Screw and Gasket
N2FA, N2FAC	Cl. I, Div. 2, Groups B, C, D	3, 7BCD, 12	Fire Alarm	Pushbutton Selector switch	1	Surface 1 gang	Screw and Gasket
N2S, N2SC N2SU, N2SCU	Cl. I, Div. 2, Groups B, C, D	3, 4X, 7BCD, 12	Pilot light Pushbutton Selector switch Combination	Pilot light Pushbutton Selector switch Combination	1-4*	Surface 1 gang	Screw and Gasket
OAC	Cl. I, Div. 1, Groups A, B, C, D Cl. I, Div. 2, Groups A, B, C, D Cl. II, Div. 1, Groups E, F, G Cl. II, Div. 2, Groups F, G Cl. III	3, 7ABCD, 9EFG, 12	Pushbutton Selector switch	Pushbutton Selector switch	1-2*	Surface 1 gang	Threaded

*Number of devices per unit.

4C



CHS Controls AB
 Florettgatan 33
 SE-254 67 Helsingborg, Sweden
 Tel +46 42 38 61 00, Fax +46 42 38 61 29
chs@chscontrols.se
www.chscontrols.se

Applications:

Five modular components – operators, contact blocks, covers, legend plates, and bodies – are combined to provide a variety of control stations which are:

- For use indoors or outdoors, in areas which are hazardous due to the presence of flammable gases and vapors, or combustible dust.
- Used in conjunction with magnetic starters or contactors for remote control of motors and other electrical apparatus.
- For installation in petroleum refineries, chemical, petrochemical, and other industrial process facilities; grain processing and storage facilities; and other heavy industrial applications where Class I, Class II, or Class III hazards are present.

Features:

- Momentary contact pushbuttons, maintained contact pushbuttons, and pilots lights offer a choice of functions.
- Selector switches in 2 or 3 position configurations including keyed and spring return options.
- Single-hole, two-hole, and three-hole covers for one, two, or three devices respectively per station.
- Rugged control devices for safe, reliable operation in industrial applications.
- Bodies, with extra room for wire pulling and termination, also include two integral mounting feet for fast, secure installation.
- Bodies have 1/2", 3/4", or 1" dead-end or through-feed conduit hubs with integral bushing for protection of wire insulation.
- Covers and bodies are available in *Feraloy*® or copper-free aluminum for light weight and corrosion resistance.
- DL legend plates have large lettering to give clear indication of device function. Space is available for field markings.

Certifications and Compliances:

- NEC
 - Class I, Division 1 & 2, Groups B* (Div. 2), C, D
 - Class II, Division 1 & 2, Groups E, F, G
 - Class III
- Zone 1 & 2 Groups IIB*
- NEMA: 3R, 7B (Div. 2) CD, 9EFG, 12
- UL Standard: 1203



Standard Materials:

- Bodies, covers – *Feraloy*® or copper-free aluminum.
- Pushbuttons and guards – Type 6 / 6 nylon.
- Operating shafts, bearings – stainless steel.

Options:

Description	Suffix
Copper-free aluminum bodies and covers	SA
Corro-free™ epoxy finish for use in severely corrosive environments. FlexStation covers and bodies.	S752

Standard Finishes:

- *Feraloy*® iron alloy – electrogalvanized and aluminum acrylic paint.
- Copper-free aluminum – natural.
- Stainless steel – natural.

Electrical Ratings:

- Pushbuttons and selector switches – 600 VAC heavy duty (NEMA A600).
- Pilot lights – 120 VAC.

Dimensions In Inches:

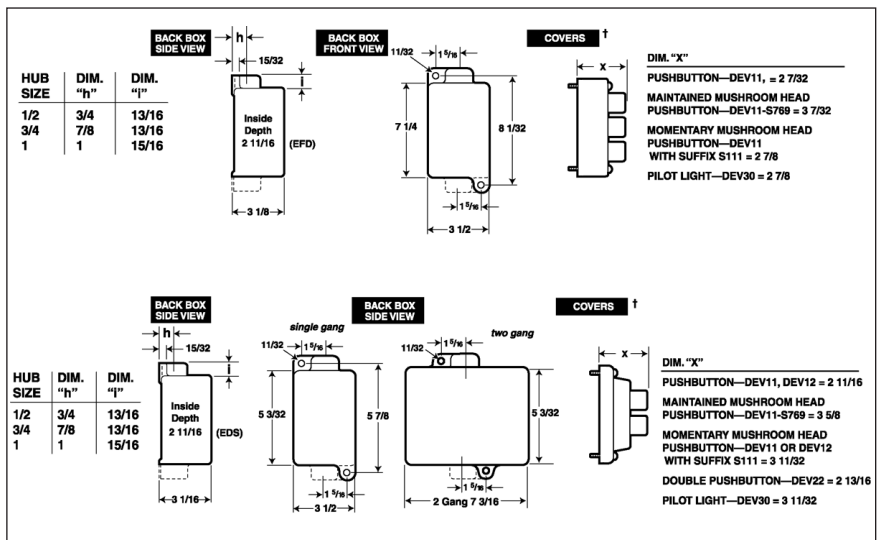

CHS Controls AB

Florettgatan 33
 SE-254 67 Helsingborg, Sweden
 Tel +46 42 38 61 00, Fax +46 42 38 61 29
 chs@chscontrols.se
 www.chscontrols.se



EDS / EFS Series Control Stations

FlexStation™ Control Station Components

Cl. I, Div. 1 & 2, Groups B (Div. 2 only) C, D
Cl. II, Div. 1 & 2, Groups E, F, G
Cl. III
Zone 1 & 2 Groups IIB
NEMA 3R, 7B* (Div. 2) CD, 9 EFG, 12

4C

4C

STEP 1 – Select Operator

Pushbutton – front operated, standard black button



Description	Cat. #
Single button for 1 contact block	DEV11
Single button for 2 contact blocks	DEV12
Double buttons for 2 contact blocks	DEV22

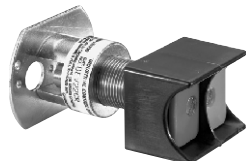

Options	Suffix
Specify color for each pushbutton button (ex: DEV11G, DEV22GR). Color is black if unspecified.	
Green button - unmarked	G
Red button - unmarked (includes lockout with bar and chain)	R
Momentary red mushroom head style (not available with lockout or with DEV22)	S111
Lockout with bar and chain (available on DEV11 and DEV12)	S153
Maintained red mushroom head style (lockout comes standard, do not specify S153; not available on DEV22)	S769



CHS Controls AB

Tel +46 42 38 61 00, Fax +46 42 38 61 29
chs@chscontrols.se www.chscontrols.se

Pilot Light – factory sealed, incandescent lamp



Description	Cat. #
Pilot light with red jewel	DEV30 J1
Pilot light with green jewel	DEV30 J3
Pilot light with amber jewel	DEV30 J6
Pilot light with clear jewel	DEV30 J10
Pilot light with blue LED and clear jewel	DEV30 J11 LED



Options	Suffix
LED lamps (standard clear jewel with colored lamp)	LED
24 V lamp (not available with transformer feature)	S300
240 / 120 V pilot light transformer	T2
480 / 120 V pilot light transformer	T4
600 / 120 V pilot light transformer	T5

Selector Switch – with standard lockout



Description	Cat. #
2-position (pos. 1 – N.O., pos. 2 – N.C.) for use with 1 or 2 contact blocks	DEV42
3-position (pos. 1 – N.O., pos. 2 – Open, pos. 3 – N.C.) for use with 1 or 2 contact blocks	DEV43
3-position (pos. 1 – N.C., pos. 2 – N.O., pos. 3 – N.O. for Switch A) (pos. 1 – N.O., pos. 2 – N.O., pos. 3 – N.C. for Switch B) for use with 2 contact blocks	DEV44



Options	Suffix
Spring return to center from right (For DEV43 or DEV44 only)	S634
Spring return to center from left (For DEV43 or DEV44 only)	S635
Spring return to center from right and left (For DEV43 or DEV44 only)	S842
Key Operated – removable from all positions	S847 K1
Key Operated – removable from left position for DEV42 or from center for DEV43 and DEV44	S847 K2
Key Operated – removable from right position for DEV42 or from left for DEV43 and DEV44	S847 K3
Key Operated – removable from right position for DEV43 and DEV44	S847 K4

STEP 2 – Select Contact Block (if required). For product details see page 557.

Contact Block



Description	Cat. #
Contact block, 1 NO and 1 NC, 10A, 600VAC, A600 rating	ESWP126

For additional technical information see page 557.

Note - Each control station will accept a maximum of three contact blocks. Select device operators accordingly. DEV12, DEV22 and DEV44 may not be used on a three-operator (DS443-SA) cover. DEV42 and DEV43 may not be used on a three-operator cover when using them with two contact blocks.

STEP 3 – Select Desired Legend Plates

For use with single hole covers

Cat. #	Inscription
DL101	Blank
DL128	Run-Jog
DL129	Hand-Auto
DL130	Forward-Reverse
DL132	Open-Close
DL133	Up-Down
DL135	In-Out
DL136	Raise-Lower
DL137	Start-Stop
DL138	Run-Off-Jog
DL139	Hand-Off-Auto
DL140	For-Off-Rev
DL141	Fast-Off-Slow
DL142	1-Off-2
DL143	Open-Off-Close
DL144	Up-Off-Down
DL148	Off-On
DL149	Auto-Off-Hand
DL165	Slow-Fast
DL186	Safe-Run
DL187	Raise-Off-Lower
DL188	Slow-Off-Fast
DL189	Odd-Off-Even
DL190	Stop-Start
DL191	On-Off
DL192	Fast-Slow
DL193	Local-Remote
DL194	Trip-Reset
DL195	Auto-Manual
DL196	Start-Emer Stop
DL197	Alarm-Silence
DL198	Maint-Manual
DL199	Test-Reset

For use with 2 or 3 hole covers

Cat. #	Inscription	Cat. #	Inscription
DL01	Blank w/no fields	DL32	Open-Close
DL02	Blank w/single field	DL33	Up-Down
DL03	Blank w/2 fields	DL35	In-Out
DL05	Start	DL36	Raise-Lower
DL06	Stop	DL37	Start-Stop
DL07	On	DL38	Run-Off-Jog
DL08	Off	DL39	Hand-Off-Auto
DL09	Run	DL40	For-Off-Rev
DL10	Jog	DL41	Fast-Off-Slow
DL11	Trip	DL42	1-Off-2
DL12	Reset	DL43	Open-Off-Close
DL13	Test	DL44	Up-Off-Down
DL14	Power On	DL46	Fast
DL15	Hand	DL47	Slow
DL16	Automatic	DL48	Off-On
DL17	Emer Stop	DL49	Auto-Off-Hand
DL18	Forward	DL65	Slow-Fast
DL19	Reverse	DL85	Safe
DL20	Open	DL86	Safe-Run
DL21	Close	DL87	Raise-Off-Lower
DL22	Up	DL88	Slow-Off-Fast
DL23	Down	DL89	Odd-Off-Even
DL24	In	DL90	Stop-Start
DL25	Out	DL91	On-Off
DL26	Raise	DL92	Fast-Slow
DL27	Lower	DL93	Local-Remote
DL28	Run-Jog	DL94	Trip-Reset
DL29	Hand-Auto	DL95	Auto-Manual
DL30	Forward-Reverse	DL96	Start-Emer Stop
		DL97	Alarm-Silence
		DL98	Maint-Manual
		DL99	Test-Reset

Note: For special markings order DL101-"desired markings" or DL01-"desired markings"

**STEP 4 – Select Cover
Covers**

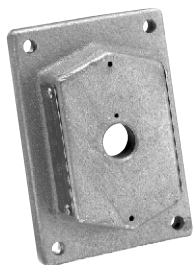

Description	Cat. #
Blank cover with single hole (Single gang)	DS441
Blank cover with 2 holes (Single gang)	DS442
Blank cover with 3 holes (To be used with EFD(C)1491-SA, 2491-SA or 3491-SA series of back boxes)	DS443 SA
Replacement cover plug for unused device operator openings	206765



Options:	Suffix
Aluminum body (mandatory suffix on DS443 must be included in catalog number)	SA
Exterior epoxy powder coat finish	S752
Interior & exterior epoxy powder coat finish. Not available on three operator cover (DS443-SA)	S753



CHS Controls AB
 Florettgatan 33
 SE-254 67 Helsingborg, Sweden
 Tel +46 42 38 61 00, Fax +46 42 38 61 29
 chs@chscontrols.se
 www.chscontrols.se

EDS / EFS Series Control Stations

FlexStation™ Control Station Components

Cl. I, Div. 1 & 2, Groups B (Div. 2 only) C, D
Cl. II, Div. 1 & 2, Groups E, F, G
Cl. III
Zone 1 & 2 Groups IIB
NEMA 3R, 7B* (Div. 2) CD, 9 EFG, 12

4C

STEP 5 – Select Back Box

Back Boxes - for use with DS441 and DS442 covers or with 1 gang and 2 gang DS/DSD Series covers

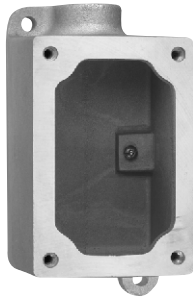

Dead End	Through Feed	Hub Size	Back Box Arrangement
EDS171	EDSC171	1/2"	Single gang back box
EDS271	EDSC271	3/4"	Single gang back box
EDS371	EDSC371	1"	Single gang back box
EDS172	EDSC172	1/2"	Double gang back box
EDS272	EDSC272	3/4"	Double gang back box
EDS372	EDSC372	1"	Double gang back box

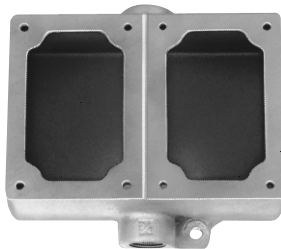

Options:

Aluminum body
Exterior epoxy powder coat finish
Interior & exterior epoxy powder coat finish

Suffix

SA
S752
S753

4C

Back Boxes – for use with DS443-SA cover or with 1½ gang DS511 (3-operator) Series covers

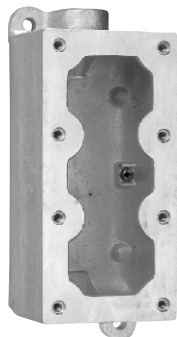

Dead End	Through Feed	Hub Size	Back Box Arrangement
EFD1491 SA	EFDC1491 SA	1/2"	1½ gang back box
EFD2491 SA	EFDC2491 SA	3/4"	1½ gang back box
EFD3491 SA	EFDC3491 SA	1"	1½ gang back box

Options

Exterior epoxy powder coat finish
Interior & exterior epoxy powder coat finish

Suffix

S752
S753



CHS Controls AB
 Florettgatan 33
 SE-254 67 Helsingborg, Sweden
 Tel +46 42 38 61 00, Fax +46 42 38 61 29
 chs@chscontrols.se
 www.chscontrols.se

EDS / EFS Series Control Stations

FlexStation™ Control Station Components

Cl. I, Div. 1 & 2, Groups B (Div. 2 only) C, D
Cl. II, Div. 1 & 2, Groups E, F, G
Cl. III
Zone 1 & 2 Groups IIB
NEMA 3R, 7B* (Div. 2) CD, 9 EFG, 12

Back Boxes – for use with DS441 and DS442 covers



Through Feed	Hub Size	Back Box Arrangement
EDSC378	1"	3 gang tandem

Common Cover Assemblies

Cat. #	Description
DS455 ①	With one pilot light
DS476 ① ②	With one pilot light and transformer
DS456 ① ①	With two pilot lights
DS429§	With one pushbutton
DS454§	With two pushbuttons
DS510 ①§	With one pushbutton and one pilot light

4C

①Add color symbol for each pilot light from table below.

Color	Symbol	Color	Symbol	Color	Symbol
Red	J1	Amber	J6	Blue	J11
Green	J3	Clear	J10		

②Add suffix below for transformer primary voltage:

Transformers – Voltages above 125

Nom. Volts 50–60Hz Transformer	Primary Voltage Range	Suffix
220 / 110	220–240	T2
440 / 110	440–480	T4
550 / 110	550–600	T5

§ If desired, markings on indicating plates may be added to catalog number. Select from the list of standard markings below:

START	OFF	RESET	LIGHT ON
STOP	RUN	TRIP	HAND
ON	JOG	TEST	AUTOMATIC
EMERGENCY	OPEN	DOWN	RAISE
FORWARD	CLOSE	IN	LOWER
REVERSE	UP	OUT	



CHS Controls AB
 Florettgatan 33
 SE-254 67 Helsingborg, Sweden
 Tel +46 42 38 61 00, Fax +46 42 38 61 29
 chs@chscontrols.se
 www.chscontrols.se

EDS / EFS Series Control Stations

EDSCM Modular Multi-Gang Control Device Bodies

Cl. I, Div. 1, Groups C, D*
Cl. I, Div. 2, Groups B, C, D
Cl. II, Div. 1, Groups E, F, G
Cl. II, Div. 2, Groups F, G
Cl. III
NEMA 3, 7B (Div. 2) CD, 9EFG

Explosionproof
Dust-Ignitionproof
Raintight
Wet Locations

4C

For use with DSD device cover sub-assemblies see page 507.

Applications:

Modular control device bodies are for surface mounting combinations of control device equipment for use in:

- Industrial areas such as chemical plants, oil and gas refineries, paint and varnish manufacturing plants, gasoline bulk loading terminals, grain elevators, grain processing industries, coal processing or handling areas where atmospheres may contain hazardous gases or dusts, and arcing of enclosed devices must not ignite the surrounding atmosphere.
- Conjunction with magnetic starters or contactors for remote control and monitoring motors.
- Manual starting and stopping of small AC or DC motors.
- Controlling and supplying energy to portable electrical devices such as motor generator sets, compressors, conveyors, portable tools, etc.

Features:

EDSCM Modular Control Stations have many distinct advantages over multiple individual units:

- Reduce installation costs. A multi-gang device assembly can be installed in less time than several single-gang units.
- Seals not required between gangs.
- Improved appearance. No exposed conduit runs between devices.
- Lightweight. Fifteen-gang aluminum device body can be installed by one person.
- Mounting feet are provided on the top and bottom of every gang to facilitate installation.
- Two and three gang tandem bodies have 1 1/4" through feed inward horizontal hubs and 1" or 2" vertical through feed hubs. Pipe plugs are installed in one horizontal hub and both vertical hubs.
- Single-gang device bodies have 1" through feed inward horizontal hubs and 3/4" through feed vertical hubs. Pipe plugs are installed in one horizontal hub and both vertical hubs.
- All hubs are taper tapped and have integral bushings.
- Close nipples, which are used to join two or more device bodies together, are furnished with EDSCM 21, 32, 33, 62 and 63 units.
- Any combination of bodies can be joined together horizontally.

Certifications and Compliances:

(When used with DSD device sub-assemblies)*:

- Class I, Division 1 & 2, Groups C, D
- Class I, Division 2, Group B, C, D
- Class II, Division 1, Groups E, F, G
- Class II, Division 2, Groups F, G
- Class III
- NEMA/EEMAC: 3, 7B (Div.2) CD, 9EFG
- UL Standard: 1203
- CSA Standard: C22.2 No. 30

Standard Materials:

- Copper-free aluminum

Finish:

- Natural

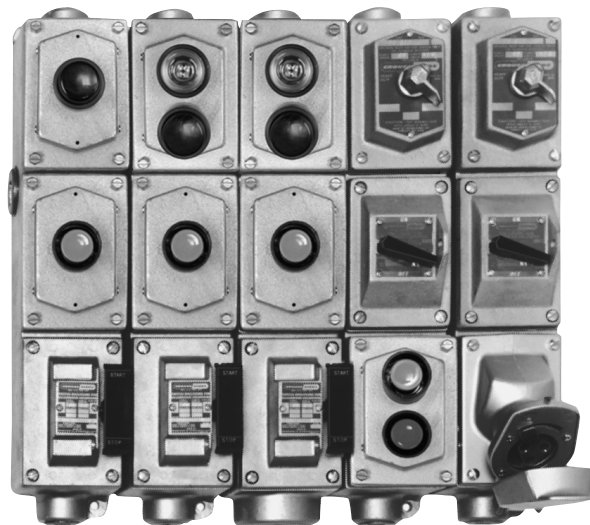

4C

Ordering Information



Description	Through Feed Hub Size	Cat. #
Single Gang	3/4"	EDSCM21
Tandem Two Gang	1"	EDSCM32
Tandem Two Gang	2"	EDSCM62
Tandem Three Gang	1"	EDSCM33
Tandem Three Gang	2"	EDSCM63

* When a CPS receptacle cover device is used, the assembly meets requirements for Class I, Groups C and D areas only.

† EDSCM32 and EDSCM62 will not accept covers with S697 or S701 suffixes.

‡ Bottom gang opening will accept covers with S697 or S701 suffixes.

In Class I areas all conduit runs entering bodies must be sealed. As many as five bodies can be joined horizontally without an intervening seal.



CHS Controls AB
 Florettgatan 33
 SE-254 67 Helsingborg, Sweden
 Tel +46 42 38 61 00, Fax +46 42 38 61 29
 chs@chscontrols.se
 www.chscontrols.se

**EDS / EFS Series
Control Stations**

**EDSCM Modular Multi-Gang
Control Device Bodies**

Cl. I, Div. 1, Groups C, D*
Cl. I, Div. 2, Groups B, C, D
Cl. II, Div. 1, Groups E, F, G
Cl. II, Div. 2, Groups F, G
Cl. III
NEMA 3, 7B (Div. 2) CD, 9EFG

Explosionproof
Dust-Ignitionproof
Raintight
Wet Locations

**Dimensions
In Inches:**

4C

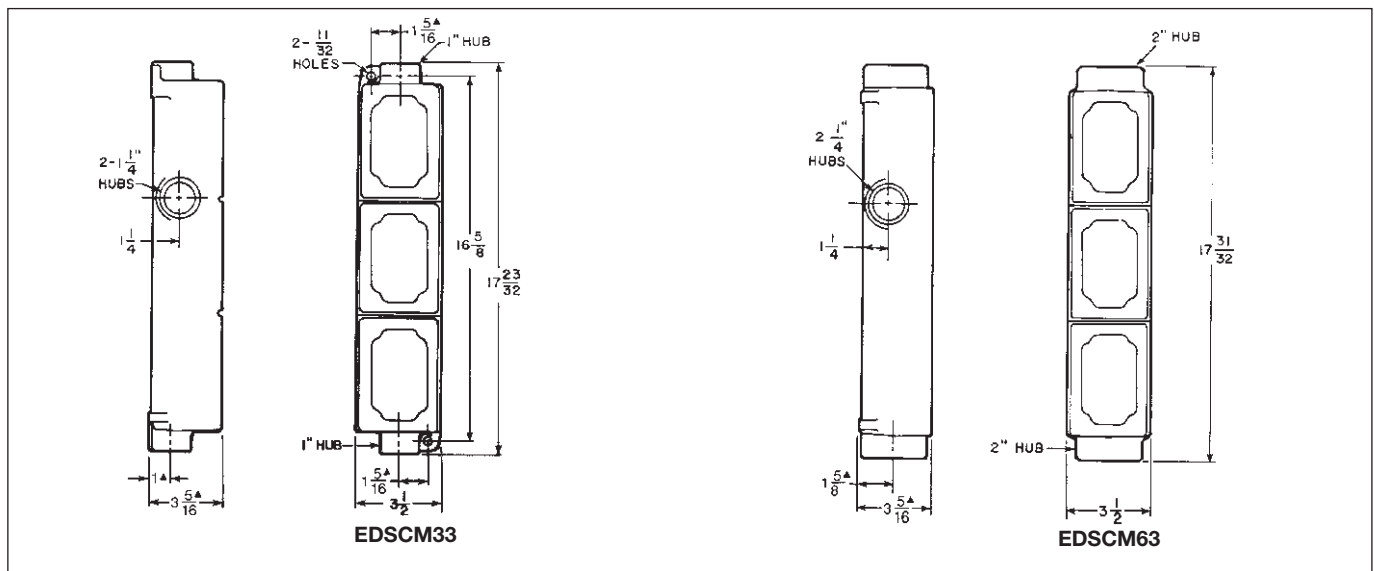
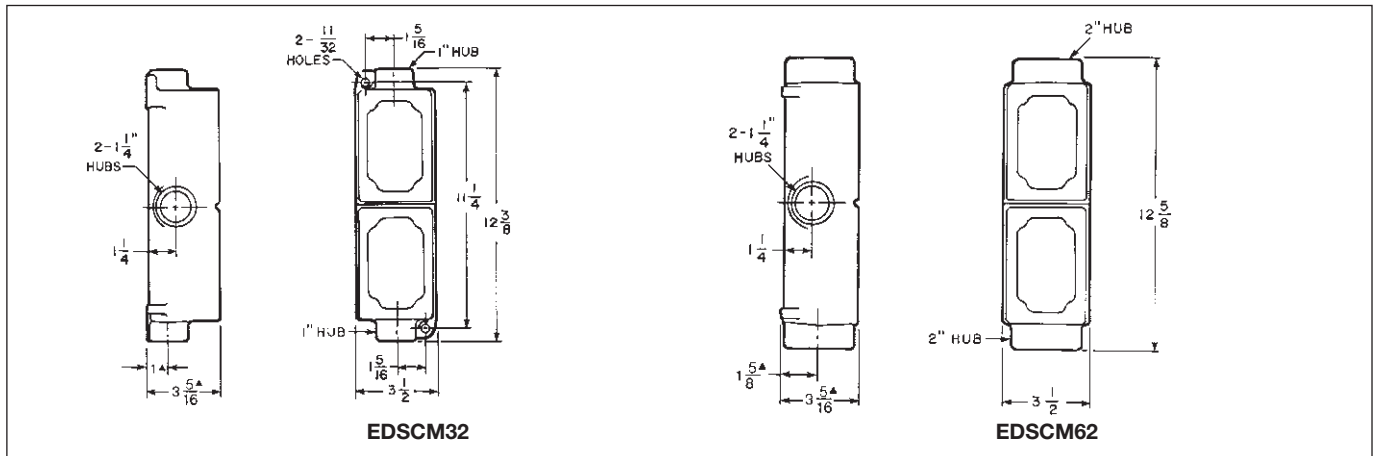
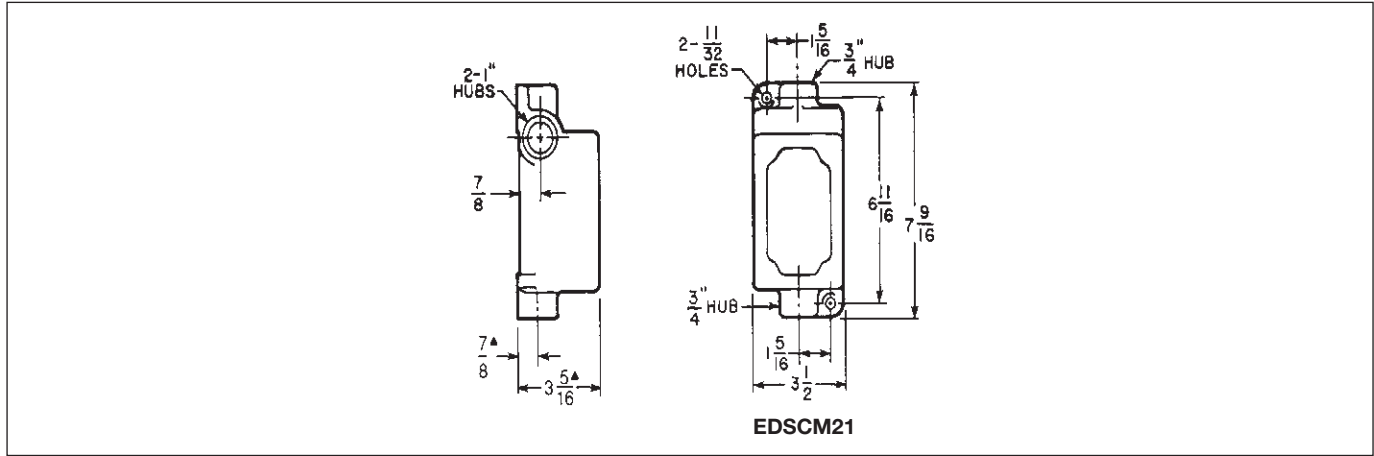

* When a CPS receptacle cover device is used, the assembly meets requirements for Class I, Groups C and D areas only. Dimensions are approximate. Not for construction purposes.

CHS controls **CHS Controls AB**
Tel +46 42 38 61 00, Fax +46 42 38 61 29
chs@chscontrols.se www.chscontrols.se

EDS / EFS Series Control Stations

DSD Cover and Device Sub-assemblies

Cl. I, Div. 1 & 2, Groups B*, C, D†
Cl. II, Div. 1, Groups E, F, G
Cl. II, Div. 2, Groups F, G
Cl. III
NEMA 3, 7B*CD, 9EFG

Explosionproof
Dust-Ignitionproof
Raintight
Wet Locations

4C

For use with EDSCM modular control device bodies see page 505 and EDS/EDSC back boxes.

Features:

- Large machine screws for fastening covers to bodies
- Lockout hole for padlock having 1/4" hasp is provided when used with covers for front lever and side rocker type operation
- Lockout provisions on front operated pushbutton (marked "STOP" and "OFF") and all selector switch covers
- For covers with front lever and side rocker type operating handles, threaded type shafts and bushings are used to ensure flametightness
- Accurately ground flange for flametight joint when mated with ground flange on back box

Certifications and Compliances:

(When used with EDSCM & EDS bodies):

- NEC/CEC:
 - Class I, Division 1 & 2, Groups C, D†
 - Class I, Division 2, Groups B, C, D
 - Class II, Division 1, Groups E, F, G
 - Class II, Division 2, Groups F, G
 - Class III
- NEMA/EMAC: 3, 7B (Div. 2) CD, 9EFG
- UL Standards: 894, 698
- CSA Standard: C22.2 No. 30

Pushbuttons, Pilot Lights & Selector Switches (when used with EFS bodies):

- NEC/CEC:
 - Class I, Division 1 & 2, Groups B, C, D
 - Class II, Division 1, Groups E, F, G
 - Class II, Division 2, Groups F, G
 - Class III
- NEMA/EMAC: 3, 7BCD, 9EFG
- UL Standard: 1203
- CSA Standard: C22.2 No. 30

Standard Materials:

- Covers, front operated – *Feraloy* iron alloy and copper-free aluminum
- Covers, side operated – copper-free aluminum
- Shafts and shaft bushings – stainless steel
- Rocker handles, pushbuttons and guards – type 6 / 6 nylon
- Sealing enclosures – copper-free aluminum

CPS delayed action receptacle cover:

- Receptacle housing – copper-free aluminum
- Insulation – diallyl phthalate (DAP)
- Contacts – brass

Standard Finishes:

- *Feraloy* – electrogalvanized and aluminum acrylic paint
- Copper-free aluminum – natural



Options:

The following special options are available by adding suffix to Cat. #:

Description	Suffix
• Lockout provision on front operated pushbutton cover (standard on buttons marked "STOP" and "OFF").....	S153
• Three-position selector switches with modified operation: Momentary contact clockwise operation, spring return to center, maintained contact counter-clockwise operation.....	S634
• Momentary contact counter-clockwise operation, spring return to center, maintained contact clockwise operation.....	S635
• Emergency "STOP" button momentary – front operated mushroom button breaks normally closed contacts (DL02 legend plate included - must specify legend text)	S111
• Bodies and covers – copper-free aluminum.....	SA
• For 24 VDC operation on pilot lights.....	S300
• Maintained contact mushroom head with lockout and guard (Will not fit with a pilot light if transformer is required).....	S769
• Spring return to center from right and left (For DEV43 or DEV44 only).....	S842
• Key Operated – removable from all positions.....	S847 K1
• Key Operated – removable from left position for DEV42 or from center for DEV43 and DEV44.....	S847 K2
• Key Operated – removable from right position for DEV42 or from left for DEV43 and DEV44.....	S847 K3
• Key Operated – removable from right position for DEV43 and DEV44.....	S847 K4

Ordering Information Manual Motor Starters

Poles	Max. H.P.	Max. Volts A.C.	Cat. #
With Allen-Bradley Bulletin 600 Switches			
1	1	115–230	DSD910 ①
2	1	115–230	DSD911 ①
With General Electric Switches			
1	1	115–230	DSD912 ①\$
2	1	115–230	DSD913 ①\$
With Cutler-Hammer Switches			
1	1	115–230	DSD914 ①\$
2	1	115–230	DSD915 ①\$
With Arrow-Hart Switches			
Without Overload Protection			
2	5	250 (30A)	DSD916
2	7.5	600 (30A)	DSD916
3	7.5	250 (30A)	DSD917
3	15	600 (20A)	DSD917



† When a CPS receptacle cover device is used, the assembly meets requirements for Class I, Groups C and D areas only.
* For pushbuttons, pilot lights, & selector switches, use EFS back box with required external conduit seal for 1 inch hub size, within 5 feet for Class I, Division 1, Group B applications.

§ A comparable factory sealed cover will fit on the EDSCM21 body, EDS and EDSC bodies and in bottom gang of EDSCM33 and EDSCM63 bodies. To order, add suffix S701 to catalog number.

① Includes one interchangeable heater. To select heater see pages 463–464.
Symbol 0 (zero) may be used to indicate heater omitted.



CHS Controls AB

Tel +46 42 38 61 00, Fax +46 42 38 61 29
chs@chscontrols.se www.chscontrols.se

EDS / EFS Series Control Stations

DSD Cover and Device Sub-Assemblies

Cl. I, Div. 1 & 2, Groups B*, C, D†
 Cl. II, Div. 1, Groups E, F, G
 Cl. II, Div. 2, Groups F, G
 Cl. III
 NEMA 3, 7B*CD, 9EFG

Explosionproof
 Dust-Ignitionproof
 Raintight
 Wet Locations

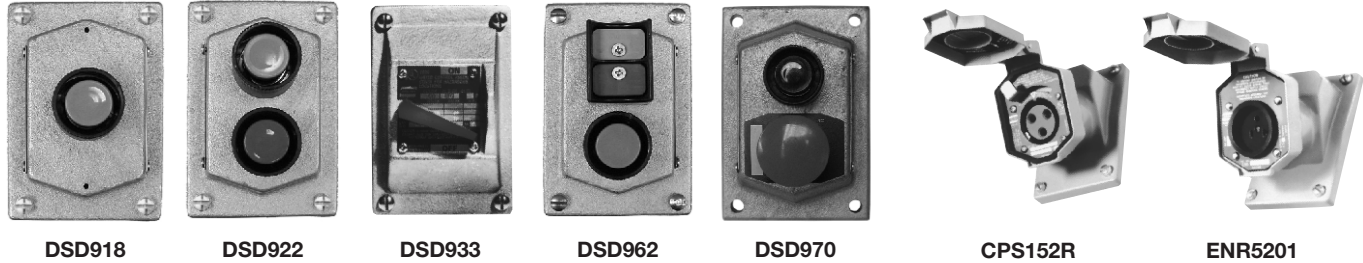

For use with EDSCM modular control device bodies see page 505 & EFS/EDS back boxes.

Ordering Information

Front Operated Pushbutton Stations 600 VAC Heavy Duty, Factory Sealed

Number of Cover Buttons	Normal Position	Diagram	Cat. #
1	1 Circuit Universal		DSD918 ①
1	2 Circuits Universal		DSD919 ①
	2 Circuits		DSD920 ①■
2	2 Circuits Universal		DSD921 ①
2	2 Circuits Start-Stop unless otherwise specified		DSD922 ①■
2	2 Circuits Universal Mushroom Head		DSD970 ①
3 (2-operator)	3 Circuits Universal		DSD962 ①
3 (3-operator)	3 Circuits Universal		DS511 ① SA‡
3 (3-operator)	3 Circuits Universal Double pilot light - single pushbutton combo		DS513 ① SA‡
3 (3-operator)	3 Circuits Universal Double pushbutton - single pilot light combo		DS514 ① SA‡

Front Operated General Use Snap Switch

Style	Amperes 120 VAC	277 VAC	Cat. #
1-Pole	20	20	DSD933‡
2-Pole	20	20	DSD934‡
3-Pole	▲	▲	DSD935⊗
3-Way	20	20	DSD936‡
4-Way	20	20	DSD937‡
1-Pole	30	30	DSD939⊗
2-Pole	30	30	DSD940⊗
3-Way	30	30	DSD941⊗

Delayed Action Receptacles Factory Sealed

Rating	Cat. #	Diagram
20 A, 1 HP, 125-250 VAC 60 Hertz 20 A, 18 VDC	CPS152R (2 wire, 3 pole)	
30 A, 1½ HP, 125-250 VAC 60 Hertz; 7 A, ½ HP, 480 VAC, 60 Hertz	CPS532R (2 wire, 3 pole)	
30 A, 3 HP, 125-250 VAC 60 Hertz; 7A, 1 HP, 480 VAC, 60 Hertz	CPS732R (3 wire, 4 pole)	
20 A, 125 VAC	ENR5201	
20 A, 250 VAC	ENR6202	

General Purpose, Dead Front Factory Sealed

① If desired, markings on indicating plates may be added to catalog number. Select from the list of standard markings below:

START	OFF	RESET	LIGHT ON
STOP	RUN	TRIP	HAND
ON	JOG	TEST	AUTOMATIC
EMERGENCY	OPEN	DOWN	RAISE
FORWARD	CLOSE	IN	LOWER
REVERSE	UP	OUT	

* For pushbuttons, pilot lights, & selector switches, use EFS back box with required external conduit seal for 1 inch hub size, within 5 feet for Class I, Division 1, Group B applications.
 † When a CPS receptacle cover device is used, the assembly meets requirements for Class I, Groups C and D areas only.

■ Two universal contact blocks, must be wired as two circuits with one normally open and one normally closed. 1 green button, 1 red button, and lockout provision provided as standard.

▲ 16 Amp., 125V.
 10 Amp., 250V.

‡ To order a comparable factory sealed cover for EDS, EDSC, EDSCM21 and the bottom gang of EDSCM33 and EDSCM63 bodies, add suffix S697.

⊗ Cannot be factory sealed.

§ Can only be used with EFD Series 1½ gang back boxes. Pushbuttons include contact blocks. Standard pushbutton color is black. For optional colors - red, green - write in color. Example: DS511 GREEN BLACK RED-SA. First color is for uppermost button. For optional legend markings write in marking after device operator color. Example: DS513-J3 JOG-J1 STOP GREEN-SA.

CHS Controls AB
 Tel +46 42 38 61 00, Fax +46 42 38 61 29
 chs@chscontrols.se www.chscontrols.se

EDS / EFS Series Control Stations

DSD Cover and Device Sub-Assemblies

Cl. I, Div. 1 & 2, Groups B*, C, D
Cl. II, Div. 1, Groups E, F, G
Cl. II, Div. 2, Groups F, G
Cl. III
NEMA 3, 7B*CD, 9EFG

Explosionproof
Dust-Ignitionproof
Raintight
Wet Locations

4C

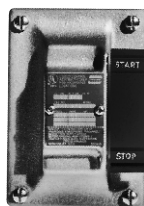

DSD951



DSD925



DSD947-J1-J1



DSD958

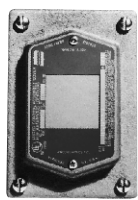

DSD957



DSD961-J1

For use with EDSCM modular control device bodies see page 505 & EFS/EDS back boxes.

Ordering Information Side Operated Pushbutton Station

600 VAC Heavy Duty, Factory Sealed

Normal Position	Diagram	Cat. #
1 Circuit Universal		DSD949 ③
2 Circuits Universal		DSD950 ③
2 Circuits 1 Open - A 1 Closed - B Start-Stop unless otherwise specified		DSD951 ③

Selector Switches

Maintained Contact 600 VAC Heavy Duty, Factory Sealed

Style	Position 1	Position 2	Position 3	Cat. #
Two Circuit	A1 A2			DSD923 ④
Two Position	Four Circuit A1 A2 B1 B2			DSD924 ④
Two Circuit	A1 A2			DSD925 ④
Two Circuit	A1 A2			DSD926 ④
Three Position	B1 B2			
Four Circuit	A1 A2 B1 B2			DSD927 ④

* For pushbuttons, pilot lights, & selector switches, use EFS back box with required external conduit seal for 1 inch hub size, within 5 feet for Class I, Division 1, Group B applications.
‡LED pilot lights can be furnished in place of standard incandescent pilot lamps. Add suffix LED to Cat. No. after last color symbol.

Pilot Light Devices‡ Factory Sealed

Description	Diagram	Cat. #
With one pilot light		DSD948 ①
With two pilot lights (Not available with a transformer)		DSD947 ①
With one pilot light and transformer		DSD948 ① ②
With one pilot light and pushbutton station		DSD958 ①
With one pilot light and 1 double pushbutton station		DSD961 ①
With one pilot light & transformer and 1 double pushbutton station		DSD961 ① ②
Triple pilot light		DS512 ① SA§
Double pilot light - single pushbutton combo		DS513 ① SA§
Double pushbutton - single pilot light combo		DS514 ① SA§

Blank Cover

Description	Cat. #
Blank Cover	DSD957

①Add color symbol for each pilot light from table below.

Color	Symbol	Color	Symbol	Color	Symbol
Red	J1	Amber	J6	Blue	J11
Green	J3	Clear	J10		

②Add suffix below for transformer primary voltage:

Transformers - Voltages above 125

Nom. Volts 50-60Hz Transformer	Primary Voltage Range	Suffix
220 / 110	220-240	T2
440 / 110	440-480	T4
550 / 110	550-600	T5

③ If desired, markings on indicating plates may be added to catalog number. Select from the list of standard markings below:

START	OFF	RESET	LIGHT ON
STOP	RUN	TRIP	HAND
ON	JOG	TEST	AUTOMATIC
EMERGENCY	OPEN	DOWN	RAISE
FORWARD	CLOSE	IN	LOWER
REVERSE	UP	OUT	

④ Specify indicating plate markings. Standard indicating plate markings available are as follows:

Two-Position		
RUN, JOG	FAST, SLOW	IN, OUT
HAND, AUTOMATIC	OPEN, CLOSE	RAISE, LOWER
FORWARD, REVERSE	UP, DOWN	START, STOP
	ON, OFF	

Three-Position

JOG, OFF, RUN	1, OFF, 2
AUTOMATIC, OFF, HAND	OPEN, OFF, CLOSE
FORWARD, OFF, REVERSE	UP, OFF, DOWN
FAST, OFF, SLOW	



CHS Controls AB

Tel +46 42 38 61 00, Fax +46 42 38 61 29
chs@chscontrols.se www.chscontrols.se

EDS / EFS Series Control Stations

Cl. I, Groups C & D
Cl. II, Groups E, F & G
Cl. III
Enclosure 3, 5 & 12

DSD-SR Series Horsepower Rated Selector Switch 30 A, 600 V; Front Operated

Ordering Information

Switch Function	Cat. #	Number of Poles	Number of Positions	Connecting Diagram
ON/OFF	DSD SR30120	1	2	
	DSD SR30220	2	2	
	DSD SR30320	3	2	
	DSD SR30420	4	2	
	DSD SR30520	5	2	
	DSD SR30620	6	2	
DOUBLE-THROW without OFF	DSD SR30121	1	2	
	DSD SR30221	2	2	
	DSD SR30321	3	2	
DOUBLE-THROW without OFF with electrically isolated contacts	DSD SR30123	1	2	
	DSD SR30223	2	2	
	DSD SR30323	3	2	
DOUBLE-THROW with OFF	DSD SR30132	1	3	
	DSD SR30232	2	3	
	DSD SR30332	3	3	
DOUBLE-THROW with OFF and electrically isolated contacts	DSD SR30134	1	3	
	DSD SR30234	2	3	
	DSD SR30334	3	3	

Electrical Specification

Voltage	Horsepower Rating	
	3PH	1PH
120	3	1.5
240	7.5	3
480	10	5
600	10	5

Maximum Current: 30 A

Heavy-duty A600 rating

Options:

Description

Lockout for 2 position switch, handle in either position

Lockout for 3 position switch, handle in either position

Suffix

SX178

S349

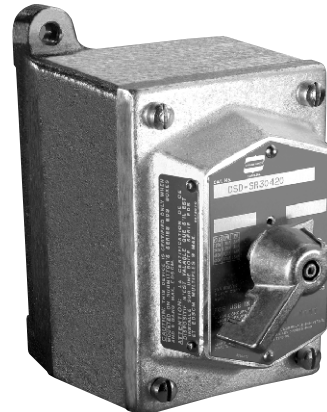

DSD-SR cover assembly shown
mounted to an EDS back box



CHS Controls AB

Florettgatan 33
SE-254 67 Helsingborg, Sweden
Tel +46 42 38 61 00, Fax +46 42 38 61 29
chs@chscontrols.se
www.chscontrols.se

EDS / EFS Series Control Stations

Fully Assembled EFS and EDS Factory Sealed Devices

Cl. I, Div. 1 & 2, Groups B*, C, D
Cl. II, Div. 1, Groups E, F, G
Cl. II, Div. 2, Groups F, G
Cl. III
NEMA 3, 7B*CD, 9EFG

Explosionproof
Dust-Ignitionproof
Raintight
Wet Locations

4C

Applications:

Factory sealed enclosures are installed in a rigid metallic conduit system for surface mounting adjacent to or remote from equipment being controlled and are used:

- To prevent arcing of enclosed device from causing ignition of a specific hazardous atmosphere or atmospheres external to the enclosure
- In industrial areas such as chemical plants, oil and gas refineries, paint and varnish manufacturing plants, gasoline bulk loading terminals, grain elevators, grain processing industries, coal processing or handling areas, or metal handling or finishing areas where atmosphere may contain hazardous gases and/or dust
- In non-hazardous areas where sturdy, durable enclosures are required
- In conjunction with magnetic starters or contactors for remote control of motors

Manual motor starting switch enclosures are used:

- For manual starting of small AC or DC motors
- To provide manual starting and stopping and, in the case of units with heaters, motor running protection

Features:

Factory sealed devices have many distinct advantages:

- Reduce installation problems
- Eliminate external seals
- Lower installation costs
- Improve safety
- Are used with general purpose snap and pushbutton type switches
- Standard neoprene covers for front operated pushbuttons. Prevents accumulation of dirt and entrance of water around operating shafts
- Mounting lugs and taper tapped hubs with integral bushings
- Large machine screws for fastening covers to bodies
- Lockout provisions on front operated pushbutton (marked "STOP" and "OFF") and selector switch covers
- Lockout hole for padlock having 1/4" hasp is provided when used with covers for front lever and side rocker type operation
- Close tolerances in machining of wide, mating flanges and journalled shafts and bearings for front button operation, produces flametightness of enclosure joints
- On enclosures with front lever and side rocker type operating handles, threaded type shafts and bushings are used to ensure flametightness
- Dead end (EFS or EDS) or through feed (EFSC or EDSC) hubs – 1/2" to 1" sizes

Certifications and Compliances:

- NEC/CEC:
 - Class I, Division 1 & 2, Groups B*, C, D
 - Class II, Division 1, Groups E, F, G
 - Class II, Division 2, Groups F, G
 - Class III
- NEMA/EEMAC: 3, 7B*CD, 9EFG
- UL Standard: 1203
- CSA Standard: C22.2 No. 30

Standard Materials:

- Bodies – *Feraloy*® iron alloy; copper-free aluminum
- Front operated pushbutton and pilot light covers – *Feraloy* iron alloy
- Side operated type pushbutton covers – copper-free aluminum
- Shafts – stainless steel
- Shaft bushings – stainless steel
- Rocker handle and pushbutton guards – type 6 / 6 nylon
- Sealing enclosures – copper-free aluminum

Standard Finishes:

- *Feraloy* iron alloy – electrogalvanized and aluminum acrylic paint
- Copper-free aluminum – natural
- Type 6 / 6 nylon – black
- Stainless steel – natural

Options:

The following special options are available from the factory by adding suffix to Cat. #:

Description	Suffix
• Emergency "Stop" button (momentary) – front operated red mushroom button.....	S111
• Lockout provision on front operated pushbutton cover (standard on buttons marked "OFF" and "STOP").....	S153
• For 24 VDC operation on pilot lights.....	S300
• Three-position selector switches with modified operation: Momentary contact clockwise operation, spring return to center, maintained contact counter-clockwise operation.....	S634
• Momentary contact counter-clockwise operation, spring return to center, maintained contact clockwise operation....	S635
• Bodies and covers (single and two gang units) – copper-free aluminum.....	SA
• Where indicated in the catalog listings, EDS units suitable for Class I, Division 1, Group B usage can be supplied, add suffix -GB, EFS units are suitable for Class I, Division 1, Group B as standard.....	GB
• Maintained contact mushroom head with lockout and guard. May not be combined with a pilot light if a transformer is required.....	S769
• Spring return to center from right and left (For DEV43 or DEV44 only).....	S842

EDS bodies and factory sealed cover and device sub-assemblies are available for field assembly (see page 507).

*See suffix GB in Options section



CHS Controls AB
 Florettgatan 33
 SE-254 67 Helsingborg, Sweden
 Tel +46 42 38 61 00, Fax +46 42 38 61 29
 chs@chscontrols.se
 www.chscontrols.se

EDS / EFS Series Control Stations

Fully Assembled EFS and EDS Factory Sealed Devices

Cl. I, Div. 1 & 2, Groups B*, C, D Explosionproof
 Cl. II, Div. 1, Groups E, F, G Dust-Ignitionproof
 Cl. II, Div. 2, Groups F, G Raintight
 Cl. III Wet Locations
 NEMA 3, 7B*CD, 9EFG



CHS Controls AB
 Tel +46 42 38 61 00, Fax +46 42 38 61 29
 chs@chscontrols.se www.chscontrols.se

Methods of Factory Sealing

EFS/EDS Series

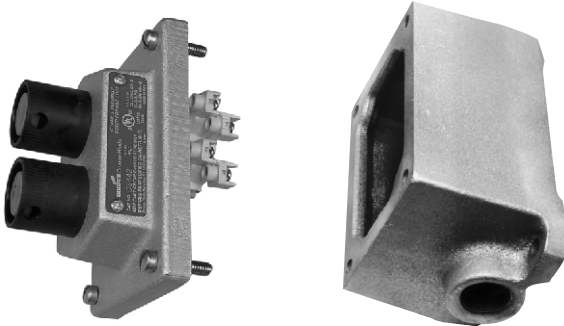

Factory sealed EDS and EFS pilot light, pushbutton and selector switch control stations do not need external sealing. Device contacts are factory sealed in explosionproof ESWP contact blocks. Small, compact enclosures have accurately ground wide flanges on both the body and cover for a flame-tight joint.

EDS Series

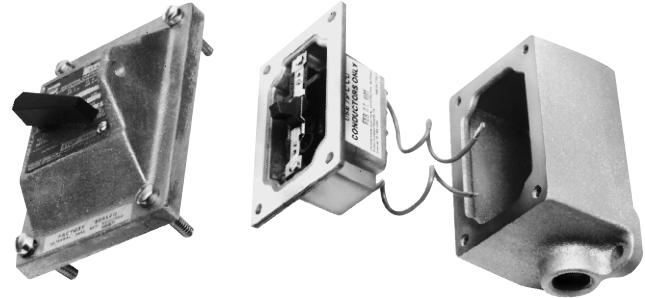

EDS factory sealed snap switches or manual motor starting switches do not need external sealing. The switches are enclosed in a unique sealing well with double flanges which mate with the cover and the body. Small, compact enclosures have accurately ground wide flanges on body, cover and sealing well for flame-tight joints. Wiring pigtailed are factory sealed from under the sealing well. Reliable pouring of seals at the factory ensures safe sealing.

Dimensions (Inches) ‡

Bodies

Hub Size	Dim. "h"	Dim. "i"
1/2	3/4	13/16
3/4	7/8	13/16
1	1	15/16

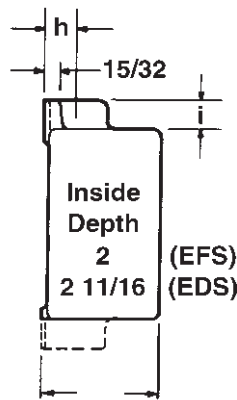

2 1/2 For EFS Series
 3 1/16 For EDS Series
 Side View

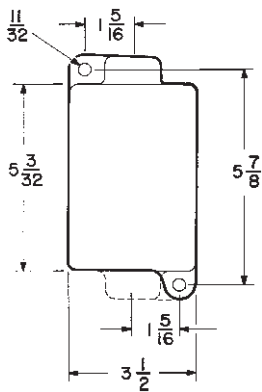

Front View - Single gang

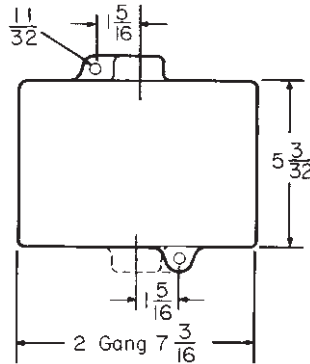

Front View - Two gang

Covers †

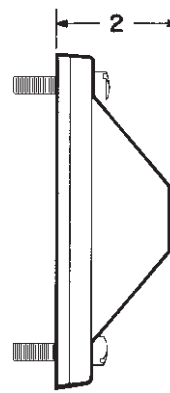

General use snap switch front operated and manual motor starting switch

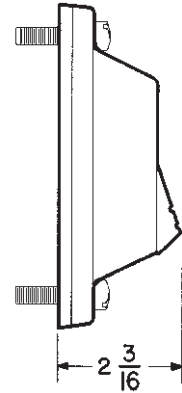

Pushbutton switch rocker type side operated

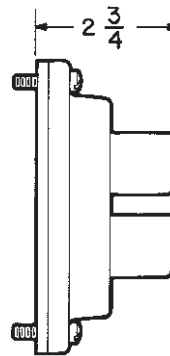

Pushbutton switch front operated

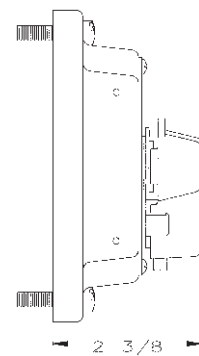

Selector switch

*See suffix GB in Options section.

‡Dimensions are approximate, not for construction purposes.

† Surface covers have same length and width as bodies.

EDS / EFS Series Control Stations

**Fully Assembled EDS Factory Sealed
Pushbutton Stations
Front Operated, 600VAC Heavy Duty**

Cl. I, Div. 1 & 2, Groups B*, C, D
Cl. II, Div. 1, Groups E, F, G
Cl. II, Div. 2, Groups F, G
Cl. III
NEMA 3, 7B*CD, 9EFG

Explosionproof
Dust-Ignitionproof
Raintight
Wet Locations

4C

Ordering Information - Single Gang

Normal Pos.	1 Circuit Universal	2 Circuits Universal	2 Circuits■	2 Circuits Universal	2 Circuits■
Marking	Specify	Specify	START-STOP unless otherwise specified	Specify	Specify
Diagram					
Replacement Pushbuttons‡	ED11	ED12	ED12■	ED12	ED12■

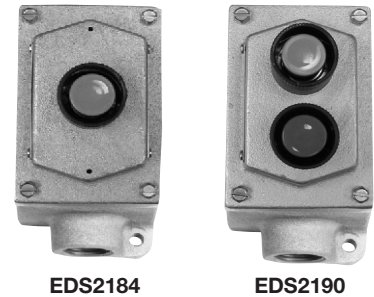

EDS2184

EDS2190

Enclosure with Pushbuttons

Hub Size	Cat. #	Cat. #	Cat. #	Cat. #§	Cat. #§
Dead End					
1/2	EDS1184 ①		EDS115 ①		EDS1155 ①
3/4	EDS2184 ①	EDS2190 ①	EDS215 ①	EDS2192 ①	EDS2155 ①
1	EDS3184 ①	EDS3190 ①	EDS315 ①	EDS3192 ①	EDS3155 ①
Through Feed					
1/2	EDSC1184 ①	EDSC1190 ①	EDSC115 ①	EDSC1192 ①	EDSC1155 ①
3/4	EDSC2184 ①	EDSC2190 ①	EDSC215 ①	EDSC2192 ①	EDSC2155 ①
1	EDSC3184 ①	EDSC3190 ①	EDSC315 ①	EDSC3192 ①	EDSC3155 ①



EDS225

Dimensions

see page 512

Ordering Information - Two Gang

Normal Pos.	1 Circuit Universal	2 Circuits Universal	2 Circuits■
Marking	Specify	Specify	START-STOP unless otherwise specified
Diagram			
Replacement Pushbuttons‡	ED11	ED12	ED12■

Enclosure with Pushbuttons

Hub Size	Cat. #	Cat. #	Cat. #
Dead End			
3/4	EDS2284 ①	EDS2290 ①	EDS225 ①
1	EDS3284 ①	EDS3290 ①	EDS325 ①
Through Feed			
1/2	EDSC1284 ①	EDSC1290 ①	EDSC125 ①
3/4	EDSC2284 ①	EDSC2290 ①	EDSC225 ①
1	EDSC3284 ①	EDSC3290 ①	EDSC325 ①

① If desired, markings on indicating plates may be added to catalog number. Select from the list of standard markings below:

START	OFF	RESET	LIGHT ON	EMERGENCY	OPEN	DOWN	RAISE
STOP	RUN	TRIP	HAND	FORWARD	CLOSE	IN	LOWER
ON	JOG	TEST	AUTOMATIC	REVERSE	UP	OUT	

* Class I, Group B: Consider using EFS series pushbuttons, see page 514. All enclosures listed above can be modified for Class I, Group B, Div. 1 usage. Add suffix GB to the Cat. No. Seals must be installed within 1/2" of each conduit opening in Division 1. These products are suitable for Group B, Div. 2 as listed, without external seals. In Canada, for Group B applications consult factory.

■ Two universal contact blocks, must be wired as two circuits, with one normally open and one normally closed.

§ Single external button operates both inner buttons simultaneously.

‡ For replacement contact blocks, see page 557.



CHS Controls AB
 Florettgatan 33
 SE-254 67 Helsingborg, Sweden
 Tel +46 42 38 61 00, Fax +46 42 38 61 29
 chs@chscontrols.se
 www.chscontrols.se

4C EDS / EFS Series Control Stations

**Fully Assembled EFS Factory Sealed
Pushbutton Stations
Front Operated, 600VAC Heavy Duty**

Cl. I, Div. 1 & 2, Groups B*, C, D
Cl. II, Div. 1, Groups E, F, G
Cl. II, Div. 2, Groups F, G
Cl. III
NEMA 3, 7B*CD, 9EFG

Explosionproof
Dust-Ignitionproof
Raintight
Wet Locations

Ordering Information

Normal Pos.	1 Circuit Universal	2 Circuits Universal	2 Circuits■	2 Circuits Universal	2 Circuits■
Marking	Specify	Specify	START-STOP unless otherwise specified	Specify	Specify
Diagram					
Replacement Pushbuttons‡	ED11	ED12	ED12■	ED12	ED12■



EFS2184



EFSC2190

Enclosure with Pushbuttons

Hub Size	Cat. #	Cat. #	Cat. #	Cat. #	Cat. #
Dead End					
1/2	EFS1184 ①		EFS115 ①		EFS1155 ①
3/4	EFS2184 ①	EFSC2190 ①	EFS215 ①	EFSC2192 ①	EFS2155 ①
1	EFS3184 ①	EFSC3190 ①	EFS315 ①	EFSC3192 ①	EFS3155 ①
Through Feed					
1/2	EFSC1184 ①	EFSC1190 ①	EFSC115 ①	EFSC1192 ①	EFSC1155 ①
3/4	EFSC2184 ①	EFSC2190 ①	EFSC215 ①	EFSC2192 ①	EFSC2155 ①
1	EFSC3184 ①	EFSC3190 ①	EFSC315 ①	EFSC3192 ①	EFSC3155 ①

Dimensions
see page 512

① If desired, markings on indicating plates may be added to catalog number. Select from the list of standard markings below:

START	OFF	RESET	LIGHT ON	EMERGENCY	OPEN	DOWN	RAISE
STOP	RUN	TRIP	HAND	FORWARD	CLOSE	IN	LOWER
ON	JOG	TEST	AUTOMATIC	REVERSE	UP	OUT	

*Class I, Group B: All enclosures listed above are suitable for Class I, Group B, Div. 1 usage. Seals only have to be installed on 1 inch conduit within 5 ft. in Division 1.
‡For replacement contact blocks, see page 557.

■Two universal contact blocks, must be wired as two circuits, with one normally open and one normally closed.
§Single external button operates both inner buttons simultaneously.



CHS Controls AB
 Florettgatan 33
 SE-254 67 Helsingborg, Sweden
 Tel +46 42 38 61 00, Fax +46 42 38 61 29
 chs@chscontrols.se
 www.chscontrols.se

EDS / EFS Series Control Stations

**Fully Assembled EDS Factory Sealed
Pushbutton Stations
Side Rocker Handle, 600VAC Heavy Duty**

Cl. I, Div. 1 & 2, Groups B*, C, D Explosionproof
Cl. II, Div. 1, Groups E, F, G Dust-Ignitionproof
Cl. II, Div. 2, Groups F, G Raintight
Cl. III Wet Locations
NEMA 3, 7B*CD, 9EFG

4C

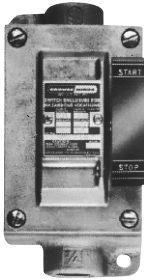

EDS2162

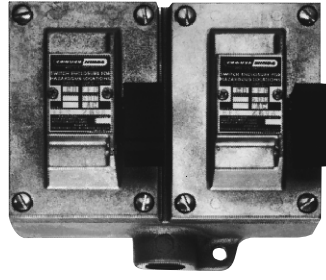

EDS2696

Dimensions

see page 512

Ordering Information - Single Gang

Normal Pos.	1 Circuit Universal	2 Circuits Universal	2 Circuits■
Marking	Specify	Specify	START-STOP unless otherwise specified
Diagram			
Replacement Pushbuttons‡	ED11	ED12	ED12■

Enclosure with Pushbuttons

Hub Size	Cat. #	Cat. #	Cat. #
Dead End			
1/2	EDS1596 ①		EDS1162 ①
3/4	EDS2596 ①	EDS2194 ①	EDS2162 ①
1	EDS3596 ①	EDS3194 ①	EDS3162 ①
Through Feed			
1/2	EDSC1596 ①	EDSC1194 ①	EDSC1162 ①
3/4	EDSC2596 ①	EDSC2194 ①	EDSC2162 ①
1	EDSC3596 ①	EDSC3194 ①	EDSC3162 ①

Two Gang

Normal Pos.	1 Circuit Universal	2 Circuits Universal	2 Circuits
Marking	Specify	Specify	START-STOP unless otherwise specified
Diagram			
Replacement Pushbuttons‡	ED11	ED12	ED12■

Enclosure with Pushbuttons

Hub Size	Cat. #	Cat. #	Cat. #
Dead End			
3/4	EDS2696 ①	EDS2294 ①	EDS2262 ①
1	EDS3696 ①	EDS3294 ①	EDS3262 ①
Through Feed			
1/2	EDSC1696 ①	EDSC1294 ①	EDSC1262 ①
3/4	EDSC2696 ①	EDSC2294 ①	EDSC2262 ①
1	EDSC3696 ①	EDSC3294 ①	EDSC3262 ①

① If desired, markings on indicating plates may be added to catalog number. Select from the list of standard markings below:

START	OFF	RESET	LIGHT ON	EMERGENCY	OPEN	DOWN	RAISE
STOP	RUN	TRIP	HAND	FORWARD	CLOSE	IN	LOWER
ON	JOG	TEST	AUTOMATIC	REVERSE	UP	OUT	

*Class I, Group B: All enclosures listed above can be modified for Class I, Group B, Div. 1 usage. Add suffix GB to the Cat. No. Seals must be installed within 1/2" of each conduit opening in Division 1. These products are suitable for Group B, Div. 2 as listed, without external seals.
‡For replacement contact blocks, see page 557.

■Two universal contact blocks, must be wired as two circuits, with one normally open and one normally closed.



CHS Controls AB
 Florettgatan 33
 SE-254 67 Helsingborg, Sweden
 Tel +46 42 38 61 00, Fax +46 42 38 61 29
 chs@chscontrols.se
 www.chscontrols.se

Cl. I, Div. 1 & 2, Groups B*, C, D
 Cl. II, Div. 1, Groups E, F, G
 Cl. II, Div. 2, Groups F, G
 Cl. III
 NEMA 3, 7B*CD, 9EFG

Explosionproof
 Dust-Ignitionproof
 Raintight
 Wet Locations

Applications:

EFS pilot lights are used:

- In areas which are hazardous due to the presence of flammable vapors, gases or highly combustible dusts
- For installation at petroleum refineries, chemical and petrochemical plants and other process industry facilities where similar hazards exist
- To visually indicate at a remote location that the desired function is being performed

Features:

- Small, compact enclosures with accurately ground flange on both body and cover for flame-tight joint
- Pilot lights are factory sealed. Conventional external seals are not required
- Dead end (EFS) or through feed (EFSC) hubs – 1/2" to 1" sizes

Certifications and Compliances:

- NEC/CEC:
 - Class I, Groups B*, C, D
 - Class II, Groups E, F, G
 - Class III
- NEMA/EEMAC: 3, 7B*CD, 9EFG
- UL Standard: 1203
- CSA Standard: C22.2

Standard Materials:

- Bodies – *Feraloy*[®] iron alloy (U.S.) and copper-free aluminum (Canada)
- Pilot light covers – *Feraloy* iron alloy
- Operating shafts – stainless steel

Standard Finishes:

- *Feraloy* iron alloy – electrogalvanized with aluminum acrylic paint
- Copper-free aluminum – natural
- Stainless steel – natural

Electrical Rating Range:

- Pilot lights – 110 to 600VAC

* External conduit seal required for 1 inch hub size in Division 1, Group B within 5 feet (1.5 meters) of enclosure.

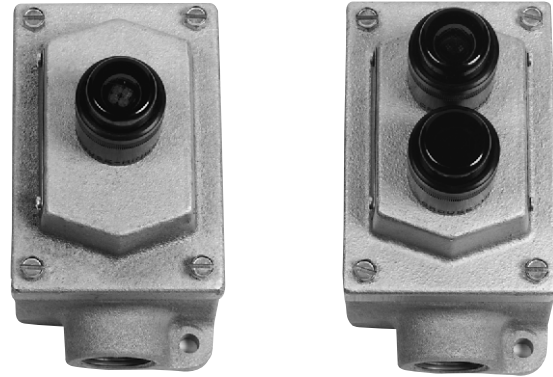

Options:

The following special options are available from factory by adding suffix to Cat. #:

Description	Suffix
Pilot lights for circuit voltages up to 600 volts maximum (standard voltage range 110–125) – See Listings	
LED pilot lights in place of standard incandescent pilot lamps	LED
Bodies and covers – copper-free aluminum	SA
24 VDC operation on pilot lights	S300



CHS Controls AB

Florettgatan 33
 SE-254 67 Helsingborg, Sweden
 Tel +46 42 38 61 00, Fax +46 42 38 61 29
 chs@chscontrols.se
 www.chscontrols.se

EDS / EFS Series Control Stations

Fully Assembled EFS Pilot Lights

Cl. I, Div. 1 & 2, Groups B*, C, D
Cl. II, Div. 1, Groups E, F, G
Cl. II, Div. 2, Groups F, G
Cl. III
NEMA 3, 7B*CD, 9EFG

Explosionproof
Dust-Ignitionproof
Raintight
Wet Locations

4C

Pilot lights listed below are factory sealed and do not require external seals*. Lamps are 6 watt, type S6, candelabra base for use on 110–125 volt circuits.

LED pilot lights can be provided in place of standard incandescent lamps by adding suffix LED after the color symbols. For Options see pages 516–517.

Enclosures with single pilot covers **only** can be equipped with a transformer for each lamp for high voltages as shown.

Transformer Voltages Above 125

Nominal Volts 50–60 Hertz Transformer	Primary Voltage Range	Cat. # Suffix
220 / 110	220–240	T2
440 / 110	440–480	T4
550 / 110	550–600	T5

Ordering Information

Enclosure with Single Pilot Light†

Hub Size	Dead End Cat. #	Through Feed Cat. #
1/2	EFS11524 ①	EFSC11524 ①
3/4	EFS21524 ①	EFSC21524 ①
1	EFS31524 ①	EFSC31524 ①

Enclosure with Double Pilot Lights‡

Hub Size	Dead End Cat. #	Through Feed Cat. #
1/2	EFS11561 ①	EFSC11561 ①
3/4	EFS21561 ①	EFSC21561 ①
1	EFS31561 ①	EFSC31561 ①

① Add color symbol for each pilot light from table below. Example: EFS11561 with red and green lights is EFS11561-J1-J3

Color	Symbol	Color	Symbol	Color	Symbol
Red	J1	Amber	J6	Blue	J11
Green	J3	Clear	J10		

Dimensions

In Inches:

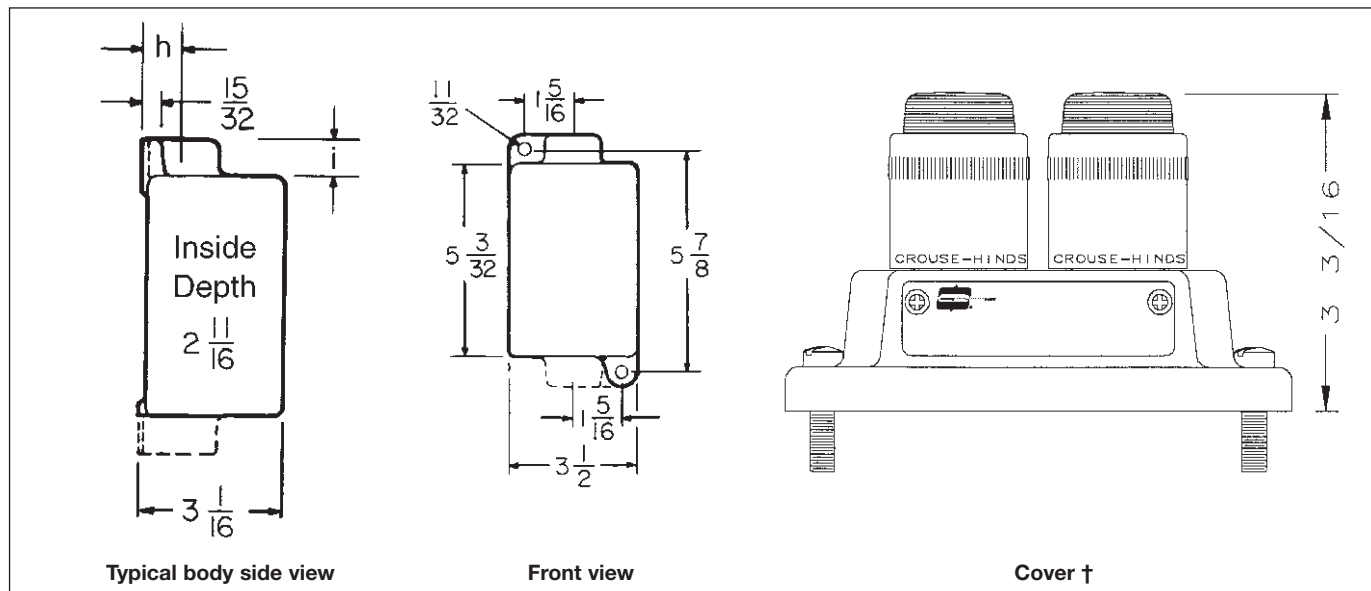

Dimensions are approximate, not for construction purposes.

Hub Size	Dim. "h"	Dim. "i"
1/2	3/4	13/16
3/4	7/8	13/16
1	1	15/16

* External conduit seal required for 1 inch hub size in Division 1, Group B within 5 feet (1.5 meters) of enclosure.

‡ LED pilot lights can be furnished in place of standard incandescent pilot lamps.

† Add suffix LED to catalog number after color symbol.

† Surface covers have same length and width dimensions as bodies.

CHS Controls AB
 Florettgatan 33
 SE-254 67 Helsingborg, Sweden
 Tel +46 42 38 61 00, Fax +46 42 38 61 29
 chs@chscontrols.se
 www.chscontrols.se

4C EDS / EFS Series Control Stations

Fully Assembled EDS Factory Sealed Combination Pushbutton and Pilot Light Stations 600VAC, Heavy Duty

Cl. I, Div. 1 & 2, Groups B*, C, D
 Cl. II, Div. 1, Groups E, F, G
 Cl. II, Div. 2, Groups F, G
 Cl. III
 NEMA 3, 7B*CD, 9EFG

Explosionproof
 Dust-Ignitionproof
 Raintight
 Wet Locations

Pushbutton contacts and pilot light receptacles are sealed in separate chambers. External seals are not required. Lamps† are 6 watt, type S6, candelabra base for use on 110–125 volt circuits.

Two gang units with single pilot light covers can be furnished with transformers. Specify markings for each button. See table below listings.

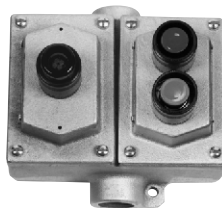

Dimensions

see page 512

4C

Ordering Information - Single Gang

Description	Dead End	Through Feed
No. Pushbuttons	1	1
No. Pilot Lights†	1	1
Diagram		

Ordering Information - Two Gang

	Dead End	Through Feed	Dead End	Through Feed
No. Pushbuttons	2	2	2	2
No. Pilot Lights†	1	1	2	2
Diagram				

Hub Size	Cat. #	Cat. #	Hub Size	Cat. #	Cat. #	Cat. #	Cat. #
1/2	EDS11473 ①②	EDSC11473 ①②	1/2	EDS12471 ①②	EDSC12471 ①②		
3/4	EDS21473 ①②	EDSC21473 ①②	3/4	EDS22471 ①②	EDSC22471 ①②	EDS22868 ①②	EDSC22868 ①②
1	EDS31473 ①②	EDSC31473 ①②	1	EDS32471 ①②	EDSC32471 ①②	EDS32868 ①②	EDSC32868 ①②

① Add color symbol for each pilot light from table below. Example: EDS21473 with a red light is EDS21473-J1

Color	Symbol	Color	Symbol	Color	Symbol
Red	J1	Amber	J6	Blue	J11
Green	J3	Clear	J10		

② If desired, markings on indicating plates may be added to catalog number. Select from the list of standard markings below:

START	LIGHT ON	DOWN	RUN	FORWARD	ON	AUTOMATIC	OUT
STOP	EMERGENCY	RAISE	TRIP	CLOSE IN	JOG	REVERSE	
RESET	OPEN	STOP	HAND	LOWER	TEST	UP	

* All enclosures listed above can be modified for Class I, Group B, Division 1 usage. Add suffix GB to the Cat. No. Example: EDS11473-J1-GB. Conduit seal(s) must be installed within 1 1/2" of each conduit opening. These products are suitable for Group B, Div. 2 as listed, without external conduit seals.

† LED pilot lights can be furnished in place of standard incandescent pilot lamps. Add suffix LED to catalog number after color symbol. For 24 VDC operation on pilot lights add suffix S300.



CHS Controls AB
 Florettgatan 33
 SE-254 67 Helsingborg, Sweden
 Tel +46 42 38 61 00, Fax +46 42 38 61 29
 chs@chscontrols.se
 www.chscontrols.se

EDS / EFS Series Control Stations

Cl. I, Div. 1 & 2, Groups B*, C, D
 Cl. II, Div. 1, Groups E, F, G
 Cl. II, Div. 2, Groups F, G
 Cl. III
 NEMA 3, 7B*CD, 9EFG

Explosionproof
 Dust-Ignitionproof
 Raintight
 Wet Locations

4C

**Fully Assembled EDS Factory Sealed
 Selector Switches
 Maintained Contact, 600VAC Heavy Duty**

Furnished with pushbuttons, cam actuated by a maintained contact selector mechanism to operate in the sequences shown in the diagrams below. Specify indicating plate markings. See table below listings.



EDS11273

Dimensions

see page 512

Ordering Information - Single Gang

Style	Position 1	Position 2	Position 3	Replacement Contact Blocks†	Enclosure with Switch		
					Hub Size	Dead End Cat. #	Through Feed Cat. #
Two-Position, Two-Circuit	A1			ED11	1/2	EDS11271 ①	EDSC11271 ①
	A2				3/4	EDS21271 ①	EDSC21271 ①
					1	EDS31271 ①	EDSC31271 ①
Two-Position, Four-Circuit	A1			ED12	1/2	EDS11272 ①	EDSC11272 ①
	A2				3/4	EDS21272 ①	EDSC21272 ①
	B1				1	EDS31272 ①	EDSC31272 ①
	B2						
Three-Position, Two-Circuit ‡	A1			ED11	1/2	EDS11273 ①	EDSC11273 ①
	A2				3/4	EDS21273 ①	EDSC21273 ①
					1	EDS31273 ①	EDSC31273 ①
Three-Position, Four-Circuit ‡	A1			ED12	1/2	EDS11274 ①	EDSC11274 ①
	A2				3/4	EDS21274 ①	EDSC21274 ①
	B1				1	EDS31274 ①	EDSC31274 ①
	B2						
	A1			ED12	1/2	EDS11275 ①	EDSC11275 ①
	A2				3/4	EDS21275 ①	EDSC21275 ①
B1	1				EDS31275 ①	EDSC31275 ①	
B2							

① If desired, markings on indicating plates may be added to catalog number. Select from the list of standard markings below:

Two-Position

RUN, JOG	FAST, SLOW	IN, OUT
HAND, AUTOMATIC	OPEN, CLOSE	RAISE, LOWER
FORWARD, REVERSE	UP, DOWN	START, STOP
	ON, OFF	

Three-Position

RUN, OFF, JOG	1, OFF, 2
HAND, OFF, AUTOMATIC	OPEN, OFF, CLOSE
FORWARD, OFF, REVERSE	UP, OFF, DOWN
FAST, OFF, SLOW	

*For Class I, Group B: Consider using EFS series selector switches, see page 520. All enclosures listed above can be modified for Class I, Group B, Div. 1 usage. Add suffix GB to the Cat. No. Seals must be installed within 1/8" of each conduit opening in Division 1. These products are suitable for Group B, Div. 2 as listed, without external seals. In Canada, for Group B applications consult factory.

† For replacement contact blocks, see page 557.

‡ Suffixes S634 or S635 may be used on these catalog numbers. See page 511 for explanation of options.

CHS Controls AB
 Tel +46 42 38 61 00, Fax +46 42 38 61 29
 chs@chscontrols.se www.chscontrols.se

4C EDS / EFS Series Control Stations

**Fully Assembled EFS Factory Sealed
Selector Switches
Maintained Contact, 600VAC Heavy Duty**

Cl. I, Div. 1 & 2, Groups B*, C, D
Cl. II, Div. 1, Groups E, F, G
Cl. II, Div. 2, Groups F, G
Cl. III
NEMA 3, 7B*CD, 9EFG

Explosionproof
Dust-Ignitionproof
Raintight
Wet Locations

Furnished with pushbuttons, cam actuated by a maintained contact selector mechanism to operate in the sequences shown in the diagrams below. Specify indicating plate markings. See table below listings.



EFS11273

Dimensions

see page 512

4C

Ordering Information - Single Gang

Style	Position 1	Position 2	Position 3	Replacement Contact Blocks†	Enclosure with Switch		
					Hub Size	Dead End Cat. #	Through Feed Cat. #
Two-Position, Two-Circuit	A1			ED11	1/2	EFS11271 ①	EFSC11271 ①
	A2				3/4	EFS21271 ①	EFSC21271 ①
					1	EFS31271 ①	EFSC31271 ①
Two-Position, Four-Circuit	A1			ED12	1/2	EFS11272 ①	EFSC11272 ①
	A2				3/4	EFS21272 ①	EFSC21272 ①
	B1				1	EFS31272 ①	EFSC31272 ①
	B2						
Three-Position, Two-Circuit ‡	A1			ED11	1/2	EFS11273 ①	EFSC11273 ①
	A2				3/4	EFS21273 ①	EFSC21273 ①
					1	EFS31273 ①	EFSC31273 ①
Three-Position, Four-Circuit ‡	A1			ED12	1/2	EFS11274 ①	EFSC11274 ①
	A2				3/4	EFS21274 ①	EFSC21274 ①
	B1				1	EFS31274 ①	EFSC31274 ①
	B2						
	A1			ED12	1/2	EFS11275 ①	EFSC11275 ①
	A2				3/4	EFS21275 ①	EFSC21275 ①
B1	1				EFS31275 ①	EFSC31275 ①	
B2							

① If desired, markings on indicating plates may be added to catalog number. Select from the list of standard markings below:

Two-Position

RUN, JOG	FAST, SLOW	IN, OUT
HAND, AUTOMATIC	OPEN, CLOSE	RAISE, LOWER
FORWARD, REVERSE	UP, DOWN	START, STOP
	ON, OFF	

Three-Position

RUN, OFF, JOG	1, OFF, 2
HAND, OFF, AUTOMATIC	OPEN, OFF, CLOSE
FORWARD, OFF, REVERSE	UP, OFF, DOWN
FAST, OFF, SLOW	



CHS Controls AB
 Florettgatan 33
 SE-254 67 Helsingborg, Sweden
 Tel +46 42 38 61 00, Fax +46 42 38 61 29
 chs@chscontrols.se
 www.chscontrols.se

*Class I, Group B: All enclosures listed above are suitable for Class I, Group B, Div. 1 usage. Seals only have to be installed on 1 inch conduit within 5 ft. in Division 1.
 † For replacement contact blocks, see page 557.
 ‡ Suffixes S634 or S635 may be used on these catalog numbers. See page 511 for explanation of options.

EDS / EFS Series Control Stations

**Fully Assembled EDS Factory Sealed
General Use Snap Switches**

Cl. I, Div. 1 & 2, Groups B*, C, D
Cl. II, Div. 1, Groups E, F, G
Cl. II, Div. 2, Groups F, G
Cl. III
NEMA 3, 7B*CD, 9EFG

Explosionproof
Dust-Ignitionproof
Raintight
Wet Locations

4C



EDS2129

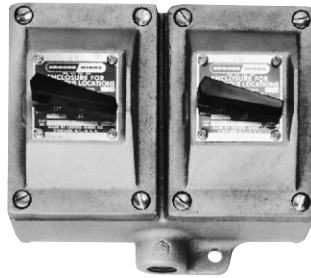

EDS2229

Dimensions
see page 512

Ordering Information - General Use Snap Switch – Front Operated

Hub Size	Style†	Amperes		Single Gang		Two Gang‡		Factory Sealed Replacement Switch
		120VAC§	277VAC§	Dead End Cat. #	Through Feed Cat. #	Dead End Cat. #	Through Feed Cat. #	
3/4	1-pole	20	20	EDS2129	EDSC2129†	EDS2229	EDSC2229†	SW5
3/4	2-pole	20	20	EDS218	EDSC218†		EDSC228†	SW6
3/4	3-way	20	20	EDS2130	EDSC2130	EDS2230	EDSC2230	SW7
3/4	4-way	20	20	EDS2140	EDSC2140		EDSC2240	SW8
1	1-pole	20	20	EDS3129	EDSC3129†	EDS3229	EDSC3229†	SW5
1	2-pole	20	20	EDS318	EDSC318†	EDS328	EDSC328†	SW6
1	3-way	20	20	EDS3130	EDSC3130	EDS3230	EDSC3230	SW7
1	4-way	20	20	EDS3140	EDSC3140	EDS3240	EDSC3240	SW8

*Class I, Group B: All units on this page can be modified for Class I, Group B usage. Add suffix GB to the Cat. No. Seals must be installed within 1/8" of each conduit opening in Division 1. In Canada, for Group B applications consult factory.

† ON-OFF standard marking for 1-pole and 2-pole units.

‡ Combinations of switches can be furnished.

§ AC rated switches are tested for resistive, inductive and tungsten filament loads up to the full current rating and for motor loads up to 80% of the ampere rating.



CHS Controls AB
 Florettgatan 33
 SE-254 67 Helsingborg, Sweden
 Tel +46 42 38 61 00, Fax +46 42 38 61 29
chs@chscontrols.se
www.chscontrols.se

4C EDS / EFS Series Control Stations

Fully Assembled EDS Factory Sealed Manual Motor Starting Switches and Enclosures

Cl. I, Div. 1 & 2, Groups B*, C, D Explosionproof
 Cl. II, Div. 1, Groups E, F, G Dust-Ignitionproof
 Cl. II, Div. 2, Groups F, G Raintight
 Cl. III Wet Locations
 NEMA 3, 7B*CD, 9EFG



EDSC2199

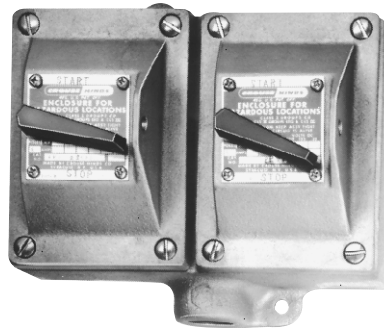

EDS2229

4C

Ordering Information

With Allen-Bradley Bulletin 600 Switches
 Maximum HP Ratings

Poles	115-230 Volts AC	115-230 Volts DC	Allen-Bradley Switch Cat. #	
1	1 hp		A B BUL 600 TOX4	
2	1 hp	3/4 hp	A B BUL 600 TOX5	
Poles	Hub Size in.	Dead End Cat. #	Through Feed Cat. #	Factory Sealed Replacement Switch
Single Gang				
1	3/4	EDS2199 ①	EDSC2199 ①	SW9
	1	EDS3199 ①	EDSC3199 ①	SW9
2	3/4	EDS21100 ①	EDSC21100 ①	SW10
	1	EDS31100 ①	EDSC31100 ①	SW10
Two Gang				
1	3/4	EDS2299 ①	EDSC2299 ①	SW9
	1	EDS3299 ①	EDSC3299 ①	SW9
2	3/4	EDS22100 ①	EDSC22100 ①	SW10
	1	EDS32100 ①	EDSC32100 ①	SW10

① Heater Table (Allen Bradley)

Max. Motor Full-Load Amps	Crouse-Hinds Symbol Number	Max. Motor Full-Load Amps	Crouse-Hinds Symbol Number
0.17	P1	2.40	P20
0.21	P2	2.58	P21
0.25	P3	2.92	P22
0.32	P4	3.09	P23
0.39	P5	3.32	P24
0.46	P6	3.77	P25
0.57	P7	4.16	P26
0.71	P8	4.51	P27
0.79	P9	4.93	P28
0.87	P10	5.43	P29
0.98	P11	6.03	P30
1.08	P12	6.83	P31
1.19	P13	7.72	P32
1.30	P14	8.24	P33
1.43	P15	8.90	P34
1.58	P16	9.60	P35
1.75	P17	10.80	P36
1.88	P18	12.00	P37
2.13	P19	13.50	P38
		15.20	P39

These heaters are for motors rated 40°C continuously. For motors rated 50°C or 55°C, multiply full load motor current by 0.9 and use this value to select heaters. Symbol 0 (zero) must be used to indicate heater omitted. Includes one interchangeable heater. Select heater from the table below individual listings and use symbol number as second section of the Cat. No. Example: EDS21101-W5. Insert symbol 0 (zero) to omit heater.

* Class I, Group B: All units on this page can be modified for Class I, Group B usage. Add suffix GB to the Cat. No. Seals must be installed within 1/8" of each conduit opening in Division 1. In Canada, for Group B applications consult factory.

① Includes one interchangeable heater. Select from the heater table and use symbol number as second section of the Cat. No. Example: EDS2199-P5. Insert symbol 0 (zero) to omit heater.



CHS Controls AB
 Florettgatan 33
 SE-254 67 Helsingborg, Sweden
 Tel +46 42 38 61 00, Fax +46 42 38 61 29
 chs@chscontrols.se
 www.chscontrols.se

EDS / EFS Series Control Stations

Fully Assembled EDS Factory Sealed Manual Motor Starting Switches and Enclosures

Cl. I, Div. 1 & 2, Groups B*, C, D Explosionproof
 Cl. II, Div. 1, Groups E, F, G Dust-Ignitionproof
 Cl. II, Div. 2, Groups F, G Raintight
 Cl. III Wet Locations
 NEMA 3, 7B*CD, 9EFG

4C

Ordering Information With General Electric Switches Maximum HP Ratings

Poles	115-230 Volts AC	115 Volts DC	230 Volts DC	G.E. Switch Cat. #
1	1 hp	1 hp	¼ hp	CR101 Y
2	1 hp	1 hp	1 hp	CR101 H

Poles	Hub Size in.	Dead End Cat. #	Through Feed Cat. #	Factory Sealed Replacement Switch
Single Gang				
1	¾	EDS21093 ①	EDSC21093 ①	SW11
	1	EDS31093 ①	EDSC31093 ①	SW11
2	¾	EDS21094 ①	EDSC21094 ①	SW12
	1	EDS31094 ①	EDSC31094 ①	SW12
Two Gang				
1	¾	EDS22093 ①	EDSC22093 ①	SW11
	1	EDS32093 ①	EDSC32093 ①	SW11
2	¾	EDS22094 ①	EDSC22094 ①	SW12
	1	EDS32094 ①	EDSC32094 ①	SW12

Ordering Information With Cutler-Hammer Switches Maximum HP Ratings

Poles	120-240 Volts AC	32 Volts DC	120 Volts DC	240 Volts DC	Cutler-Hammer Switch Cat. #
1	1 hp	¼ hp			MST01
2	1 hp	¼ hp	1 hp	1 hp	MST02

Poles	Hub Size in.	Dead End Cat. #	Through Feed Cat. #	Factory Sealed Replacement Switch
Single Gang				
1	¾	EDS21101 ①	EDSC21101 ①	SW13
	1	EDS31101 ①	EDSC31101 ①	SW13
2	¾	EDS21102 ①	EDSC21102 ①	SW14
	1	EDS31102 ①	EDSC31102 ①	SW14
Two Gang				
1	¾	EDS22101 ①	EDSC22101 ①	SW13
	1	EDS32101 ①	EDSC32101 ①	SW13
2	¾	EDS22102 ①	EDSC22102 ①	SW14
	1	EDS32102 ①	EDSC32102 ①	SW14

① Heater Table (General Electric)

Max. Motor Full-Load Amps	Crouse-Hinds Symbol Number	Max. Motor Full-Load Amps	Crouse-Hinds Symbol Number
.48	G2	3.01	G22
.53	G3	3.27	G23
.58	G4	3.56	G24
.65	G5	3.88	G25
.71	G6	4.22	G26
.78	G7	4.60	G27
.86	G8	5.00	G28
.95	G9	5.43	G29
1.04	G10	5.90	G30
1.14	G11	6.41	G31
1.25	G12	6.98	G32
1.37	G13	7.60	G33
1.49	G14	8.25	G34
1.63	G15	8.95	G35
1.78	G16	9.75	G36
1.95	G17	10.60	G37
2.13	G18	11.40	G38
2.32	G19	12.50	G39
2.53	G20	13.60	G40
2.76	G21	14.80	G41
		16.00	G42

① Heater Table (Cutler-Hammer)

Max. Motor Full-Load Amps	Crouse-Hinds Symbol Number	Max. Motor Full-Load Amps	Crouse-Hinds Symbol Number
.43	W1	2.95	W21
.48	W2	3.27	W22
.53	W3	3.59	W23
.58	W4	3.99	W24
.64	W5	4.39	W25
.71	W6	4.79	W26
.78	W7	5.26	W27
.87	W8	5.83	W28
.95	W9	6.39	W29
1.03	W10	7.03	W30
1.15	W11	7.74	W31
1.27	W12	8.46	W32
1.35	W13	9.35	W33
1.51	W14	10.30	W34
1.67	W15	11.35	W35
1.83	W16	12.47	W36
1.99	W17	13.67	W37
2.23	W18	15.12	W38
2.47	W19	16.00	W39
2.71	W20		

Dimensions

see page 512

These heaters are for motors rated 40°C continuously. For motors rated 50°C or 55°C, multiply full load motor current by 0.9 and use this value to select heaters. Symbol 0 (zero) must be used to indicate heater omitted. Includes one interchangeable heater. Select heater from the table below individual listings and use symbol number as second section of the Cat. No. Example: EDS21101-W5. Insert symbol 0 (zero) to omit heater.

*Class I, Group B: All units on this page can be modified for Class I, Group B usage. Add suffix GB to the Cat. No. Seals must be installed within 1½" of each conduit opening in Division 1. In Canada, for Group B applications consult factory.

① Includes one interchangeable heater. Select from the heater table and use symbol number as second section of the Cat. No. Example: EDS2199-P5. Insert symbol 0 (zero) to omit heater.



CHS Controls AB

Tel +46 42 38 61 00, Fax +46 42 38 61 29
 chs@chscontrols.se www.chscontrols.se

4C EDS / EFS Series Control Stations

Fully Assembled EFS Fire Alarm Station

Cl. I, Div. 1, Groups B*, C, D Explosionproof
 Cl. I, Div. 2, Groups B, C, D Dust-Ignitionproof
 Cl. II, Div. 1, Groups E, F, G Raintight
 Cl. II, Div. 2, Groups F, G Wet Locations
 Cl. III
 NEMA 3, 7B*CD, 9EFG

Applications:

EFS Fire Alarm Stations are used:

- In areas which are hazardous due to the presence of flammable vapors, gases or highly combustible dusts
- For installation at petroleum refineries, chemical and petrochemical plants and other process industry facilities where similar hazards exist
- To indicate at a remote location that a fire exists in the area

Features:

- Small, compact enclosures with accurately ground flange on both body and cover for flame-tight joint

Certifications and Compliances:

- NEC/CEC
 - Class I, Groups B*, C, D
 - Class II, Groups E, F, G
 - Class III
- NEMA/EEMAC: 3, 7B*CD, 9EFG
- UL Standard: 1203
- CSA Standard: C22.2
- As indicated under catalog listings, certain units can be supplied for Class I, Division 1, Group B (NEMA/EEMAC 7B). Seals must be installed within 1 1/2" of each conduit opening.

Standard Materials:

- Bodies – *Feraloy*® iron alloy (U.S.) and copper-free aluminum (Canada)

Standard Finishes:

- *Feraloy* iron alloy – electrogalvanized with aluminum acrylic paint
- Copper-free aluminum – natural
- Stainless steel – natural

Options:

The following special option is available from factory by adding suffix to Cat. #:

Description	Suffix
Where indicated in the catalog listings, units suitable for Class I, Division 1, Group B usage can be supplied.....	GB*



EFS21095

Ordering Information

Hub Size	Dead End Cat. #	Through Feed Cat. #
3/4	EFS21095	EFSC21095

Dimensions In Inches:

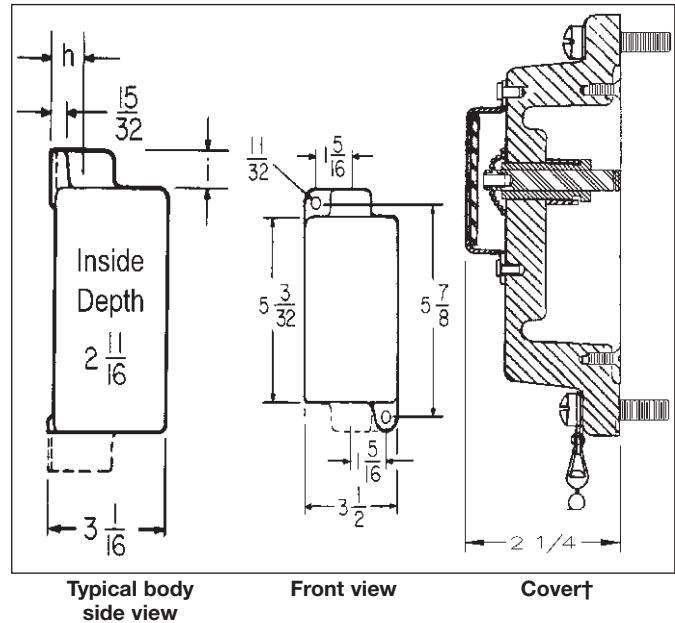

Hub Size	Dim. "h"	Dim. "i"
1/2	3/4	13/16
3/4	7/8	13/16
1	1	13/16

Dimensions are approximate, not for construction purposes.

†Surface covers have same length and width dimensions as bodies.

*Class I, Group B option: Units listed above can be modified for Class I, Division 1, Group B usage. Add suffix GB to the Cat. No. Example: EFS21095-GB. Seals must be installed within 1 1/2" of each conduit opening.



CHS Controls AB
 Florettgatan 33
 SE-254 67 Helsingborg, Sweden
 Tel +46 42 38 61 00, Fax +46 42 38 61 29
 chs@chscontrols.se
 www.chscontrols.se

Control Stations and their Sub-assemblies

Complete Control Station	Sub-assembly		Notes and Requirements
	Cover & Device	Cast Back Box	
PUSHBUTTONS			
EDS2184	DSD918	EDS271	
EDSC2184	DSD918	EDSC271	
EDS215	DSD922	EDS271	Start/ Stop Legend included
EDSC215	DSD922	EDSC271	Start/ Stop Legend included
EDS2190	DSD921	EDS271	
EDSC2190	DSD921	EDSC271	
EDS2184-S769-EM-SP	DSD918-S769-EM-SP	EDS271	Emergency Stop Legend included
EDSC2184-S769-EM-SP	DSD918-S769-EM-SP	EDSC271	Emergency Stop Legend included
EDS2284	(2) DSD918	EDS272	
EDSC2284	(2) DSD918	EDSC272	
EDS225	(2) DSD922	EDS272	Start/ Stop Legend included
EDSC225	(2) DSD922	EDSC272	Start/ Stop Legend included
EDS2290	(2) DSD921	EDS272	
EDSC2290	(2) DSD921	EDSC272	
PILOT LIGHTS			
EFS21524-J*	DSD948-J*	EDS271 †	* Insert pilot light color † When using the EFS Series pilot light in Cl. I, Div. 2 applications, the EFS back box is required in place of the EDS.
EFSC21524-J*	DSD948-J*	EDSC271 †	
EFS21561-J*-J*	DSD947-J*-J*	EDS271 †	
EFSC21561-J*-J*	DSD947-J*-J*	EDSC271 †	
PUSHBUTTON / PILOT LIGHT COMBINATIONS			
EDS21473-J*	DSD958-J*	EDS271	* Insert pilot light color
EDSC21473-J*	DSD958-J*	EDSC271	* Insert pilot light color
EDS22471-J*	DSD948-J* & DSD921	EDS272	* Insert pilot light color
EDSC22471-J*	DSD948-J* & DSD921	EDSC272	* Insert pilot light color
EDS22868-J*-J*	DSD947-J*-J* & DSD921	EDS272	* Insert pilot light color
EDSC22868-J*-J*	DSD947-J*-J* & DSD921	EDSC272	* Insert pilot light color
SELECTOR SWITCHES			
EDS21271	DSD923	EDS271	
EDSC21271	DSD923	EDSC271	
EDS21272	DSD924	EDS271	
EDSC21272	DSD924	EDSC271	
EDS21273	DSD925	EDS271	
EDSC21273	DSD925	EDSC271	
EDS21274	DSD926	EDS271	
EDSC21274	DSD926	EDSC271	
EDS21275	DSD927	EDS271	
EDSC21275	DSD927	EDSC271	
MANUAL MOTOR STARTER WITH O/L			
EDS21101	DS415A & SW13	EDS271	"-W * " for heater, or "-0" distributor provided
EDSC21101	DS415A & SW13	EDSC271	"-W * " for heater, or "-0" distributor provided
EDS21102	DS415A & SW14	EDS271	"-W * " for heater, or "-0" distributor provided
EDSC21102	DS415A & SW14	EDSC271	"-W * " for heater, or "-0" distributor provided
EDS21093	DS415A & SW11	EDS271	"-G * " for heater, or "-0" distributor provided
EDSC21093	DS415A & SW11	EDSC271	"-G * " for heater, or "-0" distributor provided
EDS21094	DS415A & SW12	EDS271	"-G * " for heater, or "-0" distributor provided
EDSC21094	DS415A & SW12	EDSC271	"-G * " for heater, or "-0" distributor provided
EDS2199	DS415A & SW9	EDS271	"-P * " for heater, or "-0" distributor provided
EDSC2199	DS415A & SW9	EDSC271	"-P * " for heater, or "-0" distributor provided
EDS21100	DS415A & SW10	EDS271	"-P * " for heater, or "-0" distributor provided
EDSC21100	DS415A & SW10	EDSC271	"-P * " for heater, or "-0" distributor provided



CHS Controls AB
 Florettgatan 33
 SE-254 67 Helsingborg, Sweden
 Tel +46 42 38 61 00, Fax +46 42 38 61 29
 chs@chscontrols.se
 www.chscontrols.se

Sub-assembly
Reference Guide

CHS Controls AB

Tel +46 42 38 61 00, Fax +46 42 38 61 29
chs@chscontrols.se www.chscontrols.se

Control Stations and their Sub-assemblies

Complete Control Station	Sub-assembly		Notes and Requirements
	Cover & Device	Cast Back Box	
MANUAL MOTOR STARTER			
EFD218-T8	DSD916	EDS271	
Alternative	DS415A & SQ D 2510 KO-1	EDS271	SQ D switch provided by distributor
EFDC218-T8	DSD916	EDSC271	
Alternative	DS415A & SQ D 2510 KO-1	EDSC271	SQ D switch provided by distributor
EFD2419	DSD917	EDS271	
Alternative	DS415A & GE 2368S	EDS271	GE switch provided by distributor
EFDC2419	DSD917	EDSC271	
Alternative	DS415A & GE 2368S	EDSC271	GE switch provided by distributor
SNAP SWITCHES			
EDS2129	DS652 & SW5	EDS271	
Alternative	DSD933	EDS271	External Sealing Fitting Required
EDSC2129	DS652 & SW5	EDSC271	
Alternative	DSD933	EDSC271	External Sealing Fitting Required
EDS218	DS652 & SW6	EDS271	
Alternative	DSD634	EDS271	External Sealing Fitting Required
EDSC218	DS652 & SW6	EDSC271	
Alternative	DSD634	EDSC271	External Sealing Fitting Required
EDS2130	DS652 & SW7	EDS271	
Alternative	DSD936	EDS271	External Sealing Fitting Required
EDSC2130	DS652 & SW7	EDSC271	
Alternative	DSD936	EDSC271	External Sealing Fitting Required
EDS2140	DS652 & SW8	EDS271	
Alternative	DSD937	EDS271	External Sealing Fitting Required
EDSC2140	DS652 & SW8	EDSC271	
Alternative	DSD937	EDSC271	External Sealing Fitting Required
EDS2229	(2) DS652 & (2) SW5	EDS272	
Alternative	(2) DSD933	EDS272	External Sealing Fitting Required
EDSC2229	(2) DS652 & (2) SW5	EDSC272	
Alternative	(2) DSD933	EDSC272	External Sealing Fitting Required
EDSC228	(2) DS652 & (2) SW6	EDSC272	
Alternative	(2) DSD634	EDSC272	External Sealing Fitting Required
EDS2230	(2) DS652 & (2) SW7	EDS272	
Alternative	(2) DSD936	EDS272	External Sealing Fitting Required
EDSC2230	(2) DS652 & (2) SW7	EDSC272	
Alternative	(2) DSD936	EDSC272	External Sealing Fitting Required
EDSC2240	(2) DS652 & (2) SW8	EDSC272	
Alternative	(2) DSD937	EDSC272	External Sealing Fitting Required
ROCKER SWITCHES			
EDS2596	DSD949	EDS271	
EDSC2596	DSD949	EDSC271	
EDS2162	DSD951	EDS271	Start/ Stop Legend included
EDSC2162	DSD951	EDSC271	Start/ Stop Legend included
EDS2194	DSD950	EDS271	
EDSC2194	DSD950	EDSC271	
EDS2696	(2) DSD949	EDS272	Start/ Stop Legend included
EDSC2696	(2) DSD949	EDSC272	Start/ Stop Legend included
EDS2262	(2) DSD951	EDS272	
EDSC2262	(2) DSD951	EDSC272	
EDS2294	(2) DSD950	EDS272	
EDSC2294	(2) DSD950	EDSC272	

Additional notes:

- See Cooper Crouse-Hinds installation instructions for any possible additional sealing requirements.
- Part numbers listed with 3/4" hub in back box (Ex. EDS2184). For 1/2" hub change the "2" to "1" (EDS1184). For 1" hub change the "2" to "3" (EDS3184).
- Control Stations with "Stop" legend have Lockout provided as standard.
- Pilot Light Colors J*-- J1= Red, J3= Green, J6= Amber, J10= Clear, J11= Blue. LED Pilot Lights are available with LED Suffix.
- Pilot Light Transformers for voltages over 125V. Suffix T2= 240/220 - 110V, T4= 480/440 - 110V, T5= 600/550 - 110V (Not available on double pilot cover).
- Standard Legend Plate markings are available by adding nomenclature after the part number (EDS2184-Run).
- Selector Switch Nameplate kits available. 2-Pos = "SS2KIT", 3-Pos = "SS3KIT". See Replacement Parts book for additional information.
- Copper-Free Aluminum Bodies and Covers available with SA Suffix.
- Additional Control Station Options may be found in section 4C.
- Group B ratings may be achieved by adding the GB suffix or using the EFS back box. See part number instructions for the item required.
- Group B ratings may already be achieved when used in Class I, Division 2 applications. See Certifications and Compliances for item required.
- Additional Control Station configurations available through the FlexStation Component series.

Pushbutton Stations, Selector Switches and Pilot Lights 600 VAC Heavy Duty

Applications:

MC pushbuttons or selector switches are used:

- In conjunction with magnetic starters or contactors for remote control of motors

MC pilot lights are used:

- To visually indicate at a remote point that the desired function is being performed (motor running, etc.)

MC pushbuttons, selector switches or pilot lights are used:

- In damp, wet or corrosive locations such as dairies, meat packing plants, chemical plants and outdoor locations

Features:

- Enclosures are compact in design, and gasketed to meet NEMA/EEMAC 3 or 4 requirements as noted in catalog listings
- Pushbutton stations with side rocker handle are furnished with a lockout arrangement on "STOP" position as standard
- Dead end (MC) or through feed (MCC) hubs – 1/2" and 3/4" sizes – with mounting feet
- Standard lockout on "STOP" and "OFF" button on front operated pushbutton covers
- Standard lockout on selector switch covers. Locks two or three position switch handle in any position.

Certifications and Complies:

- NEMA/EEMAC 3, 4
- UL Standard: 508
- CSA Encl. 3, 4, 5

Standard Materials:

- Bodies – *Feraloy*® iron alloy
- Cover with side rocker handle – copper-free aluminum
- Front pushbutton, selector switch and pilot light covers – *Feraloy* iron alloy
- Rocker handle and pushbutton guards – type 6 / 6 nylon
- Selector switch handle – copper-free aluminum
- Operating shafts – stainless steel

Standard Finishes:

- Feraloy* iron alloy – electrogalvanized and aluminum acrylic paint
- Copper-free aluminum – natural
- Type 6 / 6 nylon – black
- Stainless steel – natural

Options:

The following special options are available by adding suffix to Cat. #:

Description	Suffix
Lockout provision on front operated pushbutton (standard on buttons marked "OFF" and "STOP").....	S153
Neoprene covers for front operated pushbuttons. Meets NEMA 4 requirements and prevents accumulation of dirt around operating shafts.....	S323
Three-position selector switches with modified operation:	
Momentary contact clockwise operation, spring return to center, maintained contact counter-clockwise operation.....	S634
Momentary contact counter-clockwise operation, spring return to center, maintained contact clockwise operation.....	S635
Multiple gang bodies. Two gang, two gang tandem and three, four or five gang bodies can be supplied with combinations of single gang devices.....	Specify
LED pilot lights in place of standard incandescent pilot lamps.....	LED

Dimensions

In Inches*:

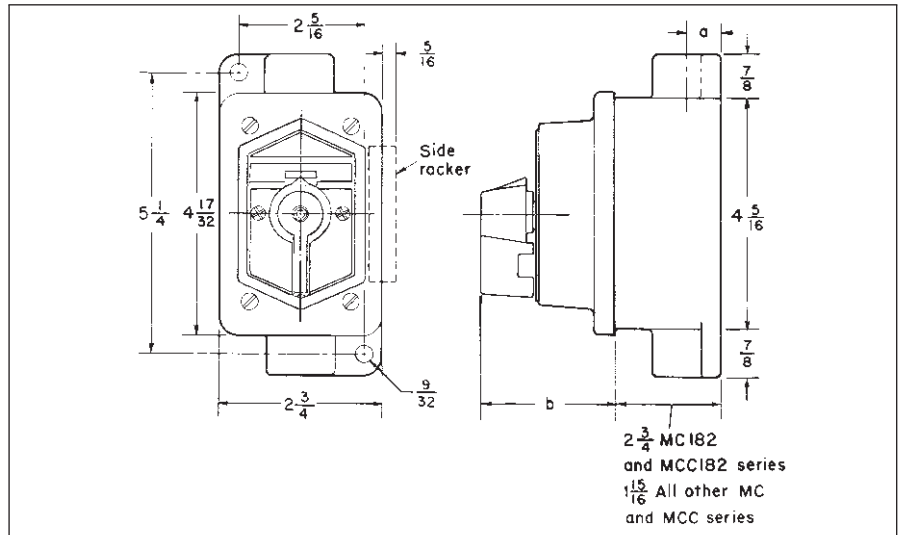

Hub size	a	Type of Cover	b
1/2	5/8	Side Rocker Handle	1 1/2
3/4	3/4	Front Pushbutton	2 3/8
		Selector Switch	2 3/8
		Pilot Light	1 1/16

*Dimensions are approximate, not for construction purposes.



CHS Controls AB
 Florettgatan 33
 SE-254 67 Helsingborg, Sweden
 Tel +46 42 38 61 00, Fax +46 42 38 61 29
 chs@chscontrols.se
 www.chscontrols.se

**Pushbutton Stations, Selector Switches
and Pilot Lights
600 VAC Heavy Duty**



MC dead end side rocker handle



MCC through feed side rocker handle



MC dead end front pushbutton



MCC through feed front pushbutton

Ordering Information - With Side Rocker Handles

Watertight, NEMA 3, 4

Normal Positions	Marking	Diagram	Replacement Contact Blocks‡	Enclosure with Rocker Handles		
				Hub Size	Dead End Cat. #	Through Feed Cat. #
1 Circuit Universal	Specify		ED11	1/2	MC1810U1 ①	MCC1810U1 ①
				3/4	MC2810U1 ①	MCC2810U1 ①
2 Circuits Universal	Specify		ED12	1/2	MC1810U ①	MCC1810U ①
				3/4	MC2810U ①	MCC2810U ①
START-STOP unless						
1 Open - A	otherwise		ED12*	1/2	MC1810 ①	MCC1810 ①
1 Closed - B	specified			3/4	MC2810 ①	MCC2810 ①

Ordering Information - With Front Pushbuttons

Weather Resistant, NEMA 3 §

Normal Positions	Marking	Diagram	Replacement Contact Blocks‡	Enclosure with Pushbuttons		
				Hub Size	Dead End Cat. #	Through Feed Cat. #
1 Circuit Universal	Specify		ED11	1/2	MC1910U1 ①	MCC1910U1 ①
				3/4	MC2910U1 ①	MCC2910U1 ①
2 Circuits Universal	Specify		ED12	1/2	MC1910U ①	MCC1910U ①
				3/4	MC2910U ①	MCC2910U ①
START-STOP unless						
1 Open - A	otherwise		ED12*	1/2	MC1910 ①	MCC1910 ①
1 Closed - B	specified			3/4	MC2910 ①	MCC2910 ①

① If desired, markings on indicating plates may be added to catalog number. Select from the list of standard markings below:

START	OFF	RESET	LIGHT ON
STOP	RUN	TRIP	HAND
ON	JOG	TEST	AUTOMATIC
EMERGENCY	OPEN	DOWN	RAISE
FORWARD	CLOSE	IN	LOWER
REVERSE	UP	OUT	



CHS Controls AB
 Florettgatan 33
 SE-254 67 Helsingborg, Sweden
 Tel +46 42 38 61 00, Fax +46 42 38 61 29
 chs@chscontrols.se
 www.chscontrols.se

*Two universal contact blocks, must be wired as two circuits, with one normally open and one normally closed.
 § For Watertight NEMA 4 rating, use suffix S323 (Neoprene button covers). See Options section.

‡For replacement pushbuttons see page 557

**Pushbutton Stations, Selector Switches
and Pilot Lights
600 VAC Heavy Duty**



MC dead end selector switch

Ordering Information - Selector Switches

Furnished with pushbutton contact blocks, cam actuated by a maintained contact selector mechanism to operate in the sequences shown in the diagrams below.

Maintained Contact				Enclosure with Selector Switch					
Style	Position 1	Position 2	Position 3	Replacement Contact Blocks*	Hub Size	Dead End Cat. #	Through Feed Cat. #		
Two-Position, Two-Circuit	A1			ED11	1/2 3/4	MC11271 ①	MCC11271 ①		
	A2					MC21271 ①	MCC21271 ①		
Two-Position, Four-Circuit	A1			ED12	1/2 3/4	MC11272 ①	MCC11272 ①		
	A2					MC21272 ①	MCC21272 ①		
	B1								
	B2								
Three-Position, Two-Circuit †	A1			ED11	1/2 3/4	MC11273 ①	MCC11273 ①		
	A2					MC21273 ①	MCC21273 ‡		
Three-Position, Four-Circuit †	A1			ED12	1/2 3/4	MC11274 ①	MCC11274 ①		
	A2					MC21274 ①	MCC21274 ①		
	B1								
	B2								
	A1					ED12	1/2 3/4	MC11275 ①	MCC11275 ①
	A2							MC21275 ①	MCC21275 ①
B1									
B2									

① If desired, markings on indicating plates may be added to catalog number. Select from the list of standard markings below:

START	OFF	RESET	LIGHT ON
STOP	RUN	TRIP	HAND
ON	JOG	TEST	AUTOMATIC
EMERGENCY	OPEN	DOWN	RAISE
FORWARD	CLOSE	IN	LOWER
REVERSE	UP	OUT	



MC dead end pilot light

Ordering Information - Pilot Lights‡

Primary Voltage Range	Lamp Base	Lamp Watts	Enclosure with Jewel Cover and Lamp		
			Hub Size	Dead End Cat. #	Through Feed Cat. #
110-125	Candelabra	6	1/2	MC180 J1	MCC180 J1
	Candelabra	6	3/4	MC-280-J1	MCC280 J1
220-250	Intermediate	10	1/2	MC184 J1	MCC184 J1
	Intermediate	10	3/4	MC-284-J1	MCC284 J1
440-480	Candelabra	6	1/2	MC182 J1	MCC182 J1
	Candelabra	6	3/4	MC282 J1	MCC282 J1

* For replacement contact blocks see page 557.

† Suffixes S634 or S635 may be used on these catalog numbers. See explanation in Options section.

‡ LED pilot lights can be furnished in place of standard incandescent pilot lamps. Add suffix LED after color symbol (J1).



CHS Controls AB
 Florettgatan 33
 SE-254 67 Helsingborg, Sweden
 Tel +46 42 38 61 00, Fax +46 42 38 61 29
 chs@chscontrols.se
 www.chscontrols.se

N2S and N2SC Series Control Stations

**Factory Sealed, Corrosion-Resistant
600VAC Heavy Duty**

Cl. I, Div. 2, Groups B, C, D
NEMA 3, 4X, 7BCD (Div. 2), 12
Watertight
Weatherproof
Dust-tight



CHS Controls AB

Florettgatan 33
SE-254 67 Helsingborg, Sweden
Tel +46 42 38 61 00, Fax +46 42 38 61 29
chs@chscontrols.se
www.chscontrols.se

Applications:

N2S and N2SC pushbutton stations, selector switches and pilot lights are suitable for use:

- In Class I, Groups B, C, D; Division 2 hazardous areas where flammable vapors or gases may be present due to accidental or abnormal operation
- In damp, wet, or corrosive locations
- Indoors or outdoors in Division 2 areas of petroleum refineries, chemical plants and other process industry facilities where similar hazards exist

N2S and N2SC pushbutton stations and selector switches are used:

- In conjunction with magnetic starters or contactors for remote control of motors
- N2S and N2SC pilot lights are used:
- To visually indicate at a remote location that the desired function is being performed

Optional maintained stop pushbutton(s) are used: As emergency or normal stop button(s) in motor control circuits for positive shutdown.

Features:

- Pushbutton stations, pilot lights, and selector switch devices are factory sealed. External seals are not required.
- Enclosures are made of *Krydon*[®] fiberglass-reinforced polyester material having excellent corrosion resistance and stability to heat and sunlight.
- Optional maintained stop feature operates by depressing the mushroom head pushbutton. Pushbutton must be manually pulled before start button can be actuated.
- Lockout is standard on selector switch devices.
- Factory installed dead end (N2S) or through feed (N2SC) hubs – 1/2", 3/4", and 1" sizes.
- Indicating plates are available with a choice of 40 standard markings.
- Grounding plate included with each hub.

Certifications and Complies:

- NEC: Class I, Division 2, Groups B, C & D
- NEMA: 3, 4X, 7BCD (Division 2) and 12
- UL Standard: 1203
- CSA Standard: C22.2 Nos. 14 & 30

Electrical Rating Ranges:

- Pushbutton stations and selector switches – heavy duty 600 VAC maximum
- Pilot lights – 120 to 600 VAC

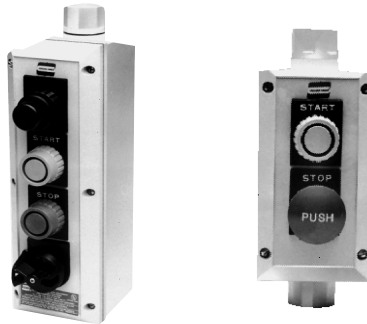

Options:

The following special options are available from factory by adding suffix to Cat. #:

Description	Suffix
Padlock attachments for all pushbuttons. For "START-STOP" stations, only "STOP" button provided with lockout.....	S708
Three position selector switches with modified operation:	
Momentary contact clockwise operation, spring return to center, maintained contact counterclockwise operation.....	S634
Momentary contact counterclockwise operation, spring return to center, maintained contact clockwise operation.....	S635
Control station with maintained stop pushbutton (requires NCD type enclosure):	
One maintained stop pushbutton.....	MSR1
Two maintained stop pushbuttons.....	MSR2
Maintained stop pushbuttons are installed at bottom position(s) of control station unless otherwise specified. LED pilot lights in place of standard incandescent pilot lamps.....	LED

Dimensions In Inches:

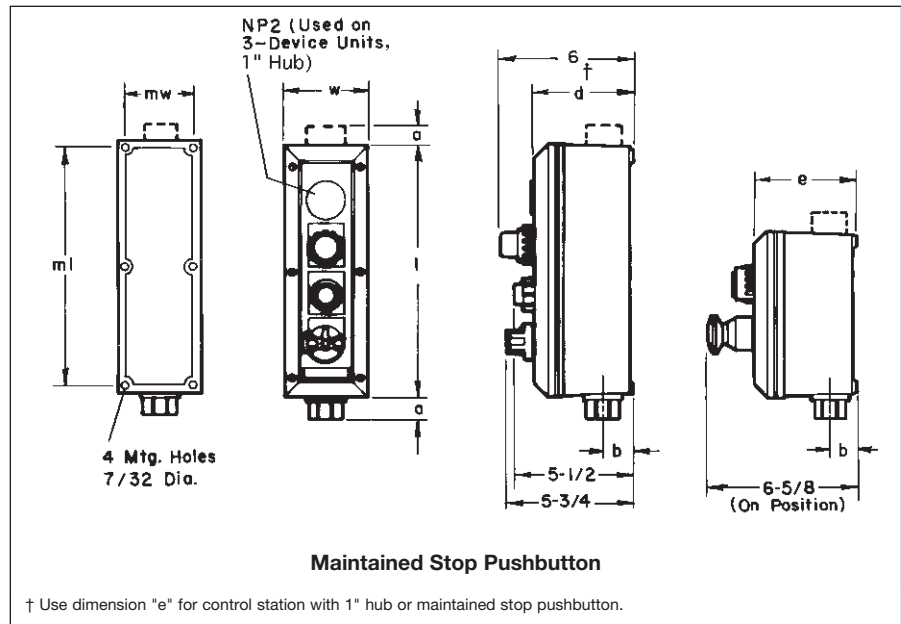

Dimensions are approximate, not for construction purposes.

N2S(C) Body Style	Outside Dims.		(NCS)* (NCD)*		Mounting Dims.		1/2" & 3/4" Hubs		1" Hubs	
	l	w	d	e	ml	mw	a	b	a	b
1 or 2 devices	7 1/4	3 13/16	4 3/8	5 3/8	6 3/8	2 15/16	1 1/8	1 1/16	1 1/4	1 3/16
3 or 4 devices	11 3/4	3 13/16	4 3/8	5 3/8	10 7/8	2 15/16	1 1/8	1 1/16	1 1/4	1 3/16

*NCS box is supplied with units using 1/2" and 3/4" hubs. NCD box is supplied with units using 1" hubs or MSR option.
‡ NCD 4 device box used with 1" hubs or MSR option.

N2S and N2SC Series Control Stations

Factory Sealed, Corrosion-Resistant
600VAC Heavy Duty

Cl. I, Div. 2, Groups B, C, D
NEMA 3, 4X, 7BCD (Div. 2), 12
Watertight
Weatherproof
Dust-tight

4C

Ordering Information - With Pilot Lights†*

No. Units	Diagram	Volts	Enclosure with Pilot Lights 1/2" Hubs		3/4" Hubs		1" Hubs	
			Dead End Cat. #	Through Feed Cat. #	Dead End Cat. #	Through Feed Cat. #	Dead End Cat. #	Through Feed Cat. #
1		120	N2S1131 ①	N2SC1131 ①	N2S2131 ①	N2SC2131 ①	N2S3131 ①	N2SC3131 ①
		240	N2S1132 ①	N2SC1132 ①	N2S2132 ①	N2SC2132 ①	N2S3132 ①	N2SC3132 ①
		480	N2S1134 ①	N2SC1134 ①	N2S2134 ①	N2SC2134 ①	N2S3134 ①	N2SC3134 ①
		600	N2S1135 ①	N2SC1135 ①	N2S2135 ①	N2SC2135 ①	N2S3135 ①	N2SC3135 ①
2		120	N2S1231 ①	N2SC1231 ①	N2S2231 ①	N2SC2231 ①	N2S3231 ①	N2SC3231 ①
		240	N2S1232 ①	N2SC1232 ①	N2S2232 ①	N2SC2232 ①	N2S3232 ①	N2SC3232 ①
		480	N2S1234 ①	N2SC1234 ①	N2S2234 ①	N2SC2234 ①	N2S3234 ①	N2SC3234 ①
		600	N2S1235 ①	N2SC1235 ①	N2S2235 ①	N2SC2235 ①	N2S3235 ①	N2SC3235 ①
3		120	N2S1331 ①	N2SC1331 ①	N2S2331 ①	N2SC2331 ①	N2S3331 ①	N2SC3331 ①
		240	N2S1332 ①	N2SC1332 ①	N2S2332 ①	N2SC2332 ①	N2S3332 ①	N2SC3332 ①
		480	N2S1334 ①	N2SC1334 ①	N2S2334 ①	N2SC2334 ①	N2S3334 ①	N2SC3334 ①
		600	N2S1335 ①	N2SC1335 ①	N2S2335 ①	N2SC2335 ①	N2S3335 ①	N2SC3335 ①
4		120	N2S1431 ①	N2SC1431 ①	N2S2431 ①	N2SC2431 ①	N2S3431 ①	N2SC3431 ①
		240	N2S1432 ①	N2SC1432 ①	N2S2432 ①	N2SC2432 ①	N2S3432 ①	N2SC3432 ①
		480	N2S1434 ①	N2SC1434 ①	N2S2434 ①	N2SC2434 ①	N2S3434 ①	N2SC3434 ①
		600	N2S1435 ①	N2SC1435 ①	N2S2435 ①	N2SC2435 ①	N2S3435 ①	N2SC3435 ①

Ordering Information - With Selector Switches

Style	Switch Position			Marking Unless Otherwise Specified	Enclosure With Selector Switch		
	1	2	3		Hub Size	Dead End Cat. #	Through Feed Cat. #
Two-Position, Two-Circuit	A1			START-STOP (or Specify)	1/2	N2S1121 ②	N2SC1121 ②
	A2				3/4	N2S2121 ②	N2SC2121 ②
Two-Position, Four-Circuit	B1			START-STOP (or Specify)	1	N2S3121 ②	N2SC3121 ②
	B2				1/2	N2S1122 ②	N2SC1122 ②
Three-Position, Two-Circuit †	A1			Specify	3/4	N2S2122 ②	N2SC2122 ②
	A2				1	N2S3122 ②	N2SC3122 ②
Three-Position, Four-Circuit †	B1			Specify	1/2	N2S1123 ②	N2SC1123 ②
	B2				3/4	N2S2123 ②	N2SC2123 ②
Three-Position, Four-Circuit †	A1			Specify	1	N2S3123 ②	N2SC3123 ②
	A2				1/2	N2S1124 ②	N2SC1124 ②
Three-Position, Four-Circuit †	B1			Specify	3/4	N2S2124 ②	N2SC2124 ②
	B2				1	N2S3124 ②	N2SC3124 ②
Three-Position, Four-Circuit †	A1			Specify	1/2	N2S1125 ②	N2SC1125 ②
	A2				3/4	N2S2125 ②	N2SC2125 ②
Three-Position, Four-Circuit †	B1			Specify	1	N2S3125 ②	N2SC3125 ②
	B2						

① Specify lens color for each pilot light. As an example, N2S1231 with one red and one green would be ordered as N2S1231-J1-J3.

Color	Symbol	Color	Symbol
Red	J1	Clear	J10
Green	J3	Blue	J11
Amber	J6		

② If desired, markings on indicating plates may be added to catalog number. Select from the list of standard markings below:

Marking

Pushbuttons:	REVERSE	Selector Switches – Two-Position:	Selector Switches – Three-Position:
START	OPEN	RUN-JOG	RUN-OFF-JOG
STOP	CLOSE	HAND-AUTO	HAND-OFF-AUTO
ON	UP	FOR-REV	FOR-OFF-REV
OFF	DOWN	FAST-SLOW	FAST-OFF-SLOW
RUN	IN	OPEN-CLOSE	1-OFF-2
JOG	OUT	UP-DOWN	OPEN-OFF-CLOSE
TRIP	RAISE	ON-OFF	UP-OFF-DOWN
RESET	LOWER	IN-OUT	
TEST		RAISE-LOWER	
LIGHT ON		START-STOP	
HAND			
AUTOMATIC			
EMERGENCY			
FORWARD			

CHS Controls AB
Tel +46 42 38 61 00, Fax +46 42 38 61 29
chs@chscontrols.se www.chscontrols.se

† Pilot lights are transformer type except those rated 120 volts. Lamp type is 120MB, 120 volts, 3 watts.
* LED pilot lights are available. Add suffix LED after last color symbol. See Options Sections for more information.
† Suffixes S634 or S635 may be used on these catalog numbers. See explanation in Options section.

N2S and N2SC Series Control Stations

Factory Sealed, Corrosion-Resistant
600VAC Heavy Duty

Cl. I, Div. 2, Groups B, C, D
NEMA 3, 4X, 7BCD (Div. 2), 12
Watertight
Weatherproof
Dust-tight

Ordering Information - With Pushbuttons – Momentary Contact

No. Units	Contact Symbol	Marking Unless Otherwise Specified	Enclosure with Pushbuttons		
			Hub Size	Dead End Cat. #	Through Feed Cat. #
1		START (or Specify)	1/2	N2S1110 ②	N2SC1110 ②
			3/4	N2S2110 ②	N2SC2110 ②
			1	N2S3110 ②	N2SC3110 ②
2		START-STOP (or Specify)	1/2	N2S1210 ②	N2SC1210 ②
			3/4	N2S2210 ②	N2SC2210 ②
			1	N2S3210 ②	N2SC3210 ②
3		Specify	1/2	N2S1310 ②	N2SC1310 ②
			3/4	N2S2310 ②	N2SC2310 ②
			1	N2S3310 ②	N2SC3310 ②
4		Specify	1/2	N2S1410 ②	N2SC1410 ②
			3/4	N2S2410 ②	N2SC2410 ②
			1	N2S3410 ②	N2SC3410 ②

Ordering Information - Combination Control Stations

Pilot Lights*	Pushbuttons	Diagram	Markings	Enclosure With Pushbuttons and Pilot Lights						
				Hub Size	Volts	Dead End Cat. #	Through Feed Cat. #	Volts	Dead End Cat. #	Through Feed Cat. #
1	1		Specify	1/2	120	N2S12411 ①②	N2SC12411 ①②	480	N2S12414 ①②	N2SC12414 ①②
				3/4		N2S22411 ①②	N2SC22411 ①②		N2S22414 ①②	N2SC22414 ①②
				1		N2S32411 ①②	N2SC32411 ①②		N2S32414 ①②	N2SC32414 ①②
			Specify	1/2	240	N2S12412 ①②	N2SC12412 ①②	600	N2S12415 ①②	N2SC12415 ①②
				3/4		N2S22412 ①②	N2SC22412 ①②		N2S22415 ①②	N2SC22415 ①②
				1		N2S32412 ①②	N2SC32412 ①②		N2S32415 ①②	N2SC32415 ①②
1	2		Specify	1/2	120	N2S13421 ①②	N2SC13421 ①②	480	N2S13424 ①②	N2SC13424 ①②
				3/4		N2S23421 ①②	N2SC23421 ①②		N2S23424 ①②	N2SC23424 ①②
				1		N2S33421 ①②	N2SC33421 ①②		N2S33424 ①②	N2SC33424 ①②
			Specify	1/2	240	N2S13422 ①②	N2SC13422 ①②	600	N2S13425 ①②	N2SC13425 ①②
				3/4		N2S23422 ①②	N2SC23422 ①②		N2S23425 ①②	N2SC23425 ①②
				1		N2S33422 ①②	N2SC33422 ①②		N2S33425 ①②	N2SC33425 ①②
2	1		Specify	1/2	120	N2S13411 ①②	N2SC13411 ①②	480	N2S13414 ①②	N2SC13414 ①②
				3/4		N2S23411 ①②	N2SC23411 ①②		N2S23414 ①②	N2SC23414 ①②
				1		N2S33411 ①②	N2SC33411 ①②		N2S33414 ①②	N2SC33414 ①②
			Specify	1/2	240	N2S13412 ①②	N2SC13412 ①②	600	N2S13415 ①②	N2SC13415 ①②
				3/4		N2S23412 ①②	N2SC23412 ①②		N2S23415 ①②	N2SC23415 ①②
				1		N2S33412 ①②	N2SC33412 ①②		N2S33415 ①②	N2SC33415 ①②
2	2		Specify	1/2	120	N2S14421 ①②	N2SC14421 ①②	480	N2S14424 ①②	N2SC14424 ①②
				3/4		N2S24421 ①②	N2SC24421 ①②		N2S24424 ①②	N2SC24424 ①②
				1		N2S34421 ①②	N2SC34421 ①②		N2S34424 ①②	N2SC34424 ①②
			Specify	1/2	240	N2S14422 ①②	N2SC14422 ①②	600	N2S14425 ①②	N2SC14425 ①②
				3/4		N2S24422 ①②	N2SC24422 ①②		N2S24425 ①②	N2SC24425 ①②
				1		N2S34422 ①②	N2SC34422 ①②		N2S34425 ①②	N2SC34425 ①②



CHS Controls AB
 Florettgatan 33
 SE-254 67 Helsingborg, Sweden
 Tel +46 42 38 61 00, Fax +46 42 38 61 29
 chs@chscontrols.se
 www.chscontrols.se

① See page 533
 ② See page 533
 * LED pilot lights are available. Add suffix LED after last color symbol. See Options Sections for more information.





N2S and N2SC Series Control Stations

**Factory Sealed, Corrosion-Resistant
600VAC Heavy Duty**

Cl. I, Div. 2, Groups B, C, D
NEMA 3, 4X, 7BCD (Div. 2), 12
Watertight
Weatherproof
Dust-tight

4C

Ordering Information - Combination Control Stations

Pilot Lights*	Push buttons	Selector Switches Position No.			Markings	Enclosure With Pilot Light, Pushbuttons and Selector Switch					
		1	2	3		Hub Size	Dead End Volts	Through Feed Cat. #	Volts	Dead End Cat. #	Through Feed Cat. #
		2-Pos, 2-Cct			Specify	1/2	N2S145211 ①②	N2SC145211 ①②	N2S145214 ①②	N2SC145214 ①②	
		3/4	120	N2S245211 ①②		N2SC245211 ①②	480	N2S245214 ①②	N2SC245214 ①②		
		1	N2S345211 ①②	N2SC345211 ①②		N2S345214 ①②	N2SC345214 ①②				
		1/2	N2S145212 ①②	N2SC145212 ①②		N2S145215 ①②	N2SC145215 ①②				
		3/4	240	N2S245212 ①②		N2SC245212 ①②	600	N2S245215 ①②	N2SC245215 ①②		
		1	N2S345212 ①②	N2SC345212 ①②		N2S345215 ①②	N2SC345215 ①②				
		3-Pos, 2-Cct			Specify	1/2	N2S145231 ①②	N2SC145231 ①②	N2S145234 ①②	N2SC145234 ①②	
		3/4	120	N2S245231 ①②		N2SC245231 ①②	480	N2S245234 ①②	N2SC245234 ①②		
		1	N2S345231 ①②	N2SC345231 ①②		N2S345234 ①②	N2SC345234 ①②				
		1/2	N2S145232 ①②	N2SC145232 ①②		N2S145235 ①②	N2SC145235 ①②				
		3/4	240	N2S245232 ①②		N2SC245232 ①②	600	N2S245235 ①②	N2SC245235 ①②		
		1	N2S345232 ①②	N2SC345232 ①②		N2S345235 ①②	N2SC345235 ①②				

① Specify lens color for each pilot light. As an example, N2S1231 with one red and one green would be ordered as N2S1231-J1-J3.

Color	Symbol	Color	Symbol
Red	J1	Clear	J10
Green	J3	Blue	J11
Amber	J6		

② If desired, markings on indicating plates may be added to catalog number. Select from the list of standard markings below:

Marking		Marking	
Pushbuttons:	REVERSE	Selector Switches – Two-Position:	Selector Switches – Three-Position:
START	OPEN	RUN-JOG	RUN-OFF-JOG
STOP	CLOSE	HAND-AUTO	HAND-OFF-AUTO
ON	UP	FOR-REV	FOR-OFF-REV
OFF	DOWN	FAST-SLOW	FAST-OFF-SLOW
RUN	IN	OPEN-CLOSE	1-OFF-2
JOG	OUT	UP-DOWN	OPEN-OFF-CLOSE
TRIP	RAISE	ON-OFF	UP-OFF-DOWN
RESET	LOWER	IN-OUT	
TEST		RAISE-LOWER	
LIGHT ON		START-STOP	
HAND			
AUTOMATIC			
EMERGENCY			
FORWARD			



CHS Controls AB
 Florettgatan 33
 SE-254 67 Helsingborg, Sweden
 Tel +46 42 38 61 00, Fax +46 42 38 61 29
 chs@chscontrols.se
 www.chscontrols.se

‡ Pilot lights are transformer type except those rated 120 volts. Lamp type is 120MB, 120 volts, 3 watts.
 * LED pilot lights are available. Add suffix LED after last color symbol. See Options Sections for more information.
 † Suffixes S634 or S635 may be used on these catalog numbers. See explanation in Options section.

Ordering Information - Custom-Built, Factory Assembled Control Stations

To order your custom-built factory assembled control station, select the enclosure required and add the desired devices from listings below.

Custom-built factory assembled control stations may thus be ordered as follows:

Requirements:

3-device control station on *Krydon*® material enclosure with 3/4" through feed hubs, with 1 pilot light with green jewel, rated at 120V; 1 three position, two circuit selector switch marked HAND-OFF-AUTO; and 1 green single circuit pushbutton marked START.

ORDER:

NCDC23FA

N2P310-J3

N2SW11311-HAND-OFF-AUTO

N2PS1111G-START

Pilot light jewel symbol, pushbutton and selector switch plate markings are selected from footnote tables. Suffix FA indicates factory assembled.

Note that order of assembly of control stations should be listed in desired mounting order, reading from top to bottom of enclosure.

Enclosures (NCD or NCDC enclosures must be used with MSR1 or MSR2)

No. of Devices	Without Hubs Cat. #	With One Hub 1/2" Cat. #	With Two Hub 1/2" Cat. #	With One Hub 3/4" Cat. #	With Two Hub 3/4" Cat. #	With One Hub 1" Cat. #	With Two Hub 1" Cat. #
1	NCD01	NCD11	NCDC11	NCD21	NCDC21	NCD31	NCDC31
2	NCD02	NCD12	NCDC12	NCD22	NCDC22	NCD32	NCDC32
3	NCD03	NCD13	NCDC13	NCD23	NCDC23	NCD33	NCDC33
4	NCD04	NCD14	NCDC14	NCD24	NCDC24	NCD34	NCDC34

No. of Devices	Without Hubs Cat. #	With One Hub (3/4") Cat. #	With Two Hub (3/4") Cat. #	With One Hub (1/2") Cat. #	With Two Hub (1/2") Cat. #
1	NCS01	NCS21	NCSC21	NCS11	NCSC11
2	NCS02	NCS22	NCSC22	NCS12	NCSC12
3	NCS03	NCS23	NCSC23	NCS13	NCSC13
4	NCS04	NCS24	NCSC24	NCS14	NCSC14

Pilot Lights†*

Volts	Transformer Type Cat. #
120	N2PL10 ①
240	N2PL20 ①
480	N2PL40 ①
600	N2PL50 ①

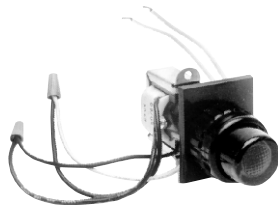

Pilot lights to be used in N2SU Series:

Red	N2PLU10 J1 LED
Green	N2PLU10 J3 LED
Amber	N2PLU10 J6 LED
Clear	N2PLU10 J10 LED
Blue	N2PLU10 J11 LED

① Specify lens color for each pilot light using symbols below.

Color	Symbol	Color	Symbol
Red	J1	Clear	J10
Green	J3	Blue	J11
Amber	J6		

† Pilot lights are transformer type except those rated 120 volts. Lamp type is 120MB, 120 volts, 3 watts.
* LED pilot lights are available. Add suffix LED after last color symbol. See Options Sections for more information.



CHS Controls AB
 Florettgatan 33
 SE-254 67 Helsingborg, Sweden
 Tel +46 42 38 61 00, Fax +46 42 38 61 29
 chs@chscontrols.se
 www.chscontrols.se

N2S and N2SC Series Control Stations

**Factory Sealed, Corrosion-Resistant
600VAC Heavy Duty**

Cl. I, Div. 2, Groups B, C, D
NEMA 3, 4X, 7BCD (Div. 2), 12
Watertight
Weatherproof
Dust-tight

4C

Pushbutton Stations – Momentary Contact

Color of Operator	1 Circuit		2 Circuit	
	Contact Symbol	Universal Cat. #	Contact Symbol	Universal Cat. #
Natural		N2PS1111 ②		N2PS1211 ②
Red		N2PS1111R ②		N2PS1211R ②
Green		N2PS1111G ②		N2PS1211G ②
Red Mushroom Head		N2PM1111 S111 ②		



Closure Plug



Description	Cat. #
Closure Plug	NP2

Selector Switches

Style	Position 1	Position 2	Position 3	Cat. #
Two Position Two Circuit	A1 A2			N2SW11211 ②
Two Position Four Circuit	A1 A2 B1 B2			N2SW12221 ②
Three Position Two Circuit †	A1 A2			N2SW11311 ②
Three Position Four Circuit †	A1 A2 B1 B2			N2SW12321 ②
Three Position Four Circuit †	A1 A2 B1 B2			N2SW12322 ②



② If desired, markings on indicating plates may be added to catalog number. Select from the list of standard markings below:

Marking

Pushbuttons: START STOP ON OFF RUN JOG TRIP RESET TEST LIGHT ON HAND AUTOMATIC EMERGENCY FORWARD	REVERSE OPEN CLOSE UP DOWN IN OUT RAISE LOWER	Selector Switches – Two-Positions: RUN-JOG HAND-AUTO FOR-REV FAST-SLOW OPEN-CLOSE UP-DOWN ON-OFF IN-OUT RAISE-LOWER START-STOP	Selector Switches – Three-Position: RUN-OFF-JOG HAND-OFF-AUTO FOR-OFF-REV FAST-OFF-SLOW 1-OFF-2 OPEN-OFF-CLOSE UP-OFF-DOWN
--	---	---	--

† Suffixes S634 or S635 may be used on these catalog numbers. See explanation in Options section.



CHS Controls AB
 Florettgatan 33
 SE-254 67 Helsingborg, Sweden
 Tel +46 42 38 61 00, Fax +46 42 38 61 29
 chs@chscontrols.se
 www.chscontrols.se

N2S and N2SC Series Control Stations

Factory Sealed, Corrosion-Resistant
600VAC Heavy Duty

Cl. I, Div. 2, Groups B, C, D
NEMA 3, 4X, 7BCD (Div. 2), 12
Watertight
Weatherproof
Dust-tight

Dimensions In Inches:

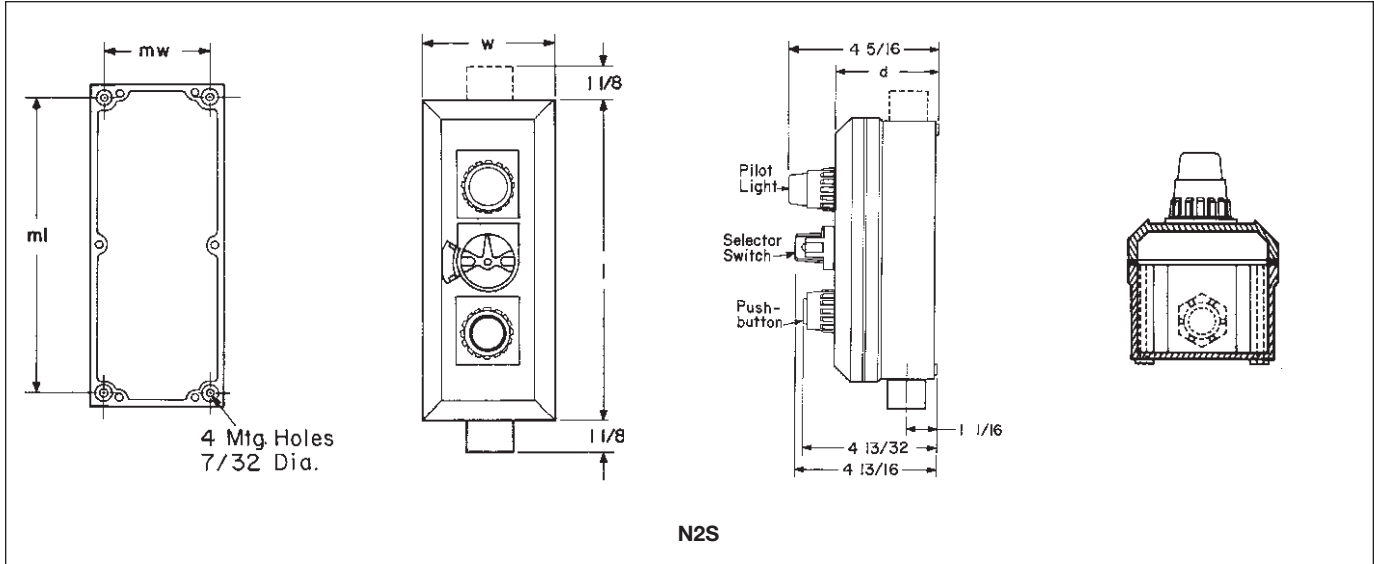

For 1/2" and 3/4" hub sizes (for 1" hub and/or MSR option, see page 530).

N2S(C) Body Style	Outside Dimensions			Mounting Dimensions	
	l	w	d	ml	mw
1 device	7 1/4	3 13/16	4 3/8	6 3/8	21 5/16
2 devices	7 1/4	3 13/16	4 3/8	6 3/8	21 5/16
3 devices	9 1/2	3 13/16	4 3/8	8 5/8	21 5/16
4 devices	11 3/4	3 13/16	4 3/8	10 7/8	21 5/16

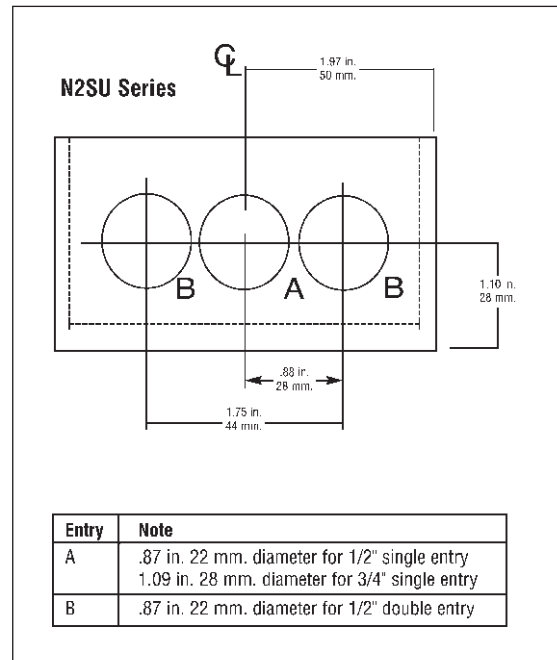



CHS Controls AB
 Florettgatan 33
 SE-254 67 Helsingborg, Sweden
 Tel +46 42 38 61 00, Fax +46 42 38 61 29
 chs@chscontrols.se
 www.chscontrols.se

N2SU/N2SCU Control Stations

**Factory Sealed, Corrosion-Resistant
600VAC Heavy Duty**

Cl. I, Div. 2, Groups B, C, D
Corrosion-Resistant
Dust-tight
Watertight
Weatherproof
NEMA 3, 4X, 7BCD (Div. 2), 12

Cl. II, Div. 2, Groups F, G
Cl. I, Zones 1 and 2, Ex de IIB + H₂
IP66

4C



CHS Controls AB

Tel +46 42 38 61 00, Fax +46 42 38 61 29
chs@chscontrols.se www.chscontrols.se

Applications:

N2SU and N2SCU pushbutton stations, selector switches and pilot lights are suitable for use:

- In Class I, Groups B, C, D; Division 2 and Class I, Zones 1 and 2 hazardous areas where flammable vapors or gases may be present due to accidental or abnormal operation
- In damp, wet, or corrosive locations
- Indoors or outdoors in Division 2 and Class I, Zones 1 and 2 areas of petroleum refineries, chemical plants and other process industry facilities where similar hazards exist

N2SU and N2SCU pushbutton stations and selector switches are used:

- In conjunction with magnetic starters or contactors for remote control of motors
- N2SU and N2SCU pilot lights are used:
- To visually indicate at a remote location that the desired function is being performed

Optional maintained stop pushbutton(s) are used: As emergency or normal stop button(s) in motor control circuits for positive shutdown.

Features:

- Compact, strong, durable enclosures are made of *Vestamid™* – a black molded high impact strength, polyester material having excellent corrosion resistance and stability to heat.
- Exterior parts of pushbuttons, pilot lights, and selector switches are made of *Krydon* material. See pages 538–539 for device part numbers
- Pushbutton design uses a unique internal neoprene boot which completely encloses all internal parts. A wiping gasket around the pushbutton cleans the wall of the pushbutton guard of any foreign material accumulation as the button is operated.
- Formed-in-place gasket, and stainless steel screws for added corrosion resistance.
- Pushbutton and pilot light guards are fluted for no-slip installation.
- Factory installed dead end (N2SU) or through feed (N2SCU) hubs – 1/2" and 3/4" sizes.
- Legend plates are available with 40 standard markings.
- Lockout is standard on selector switch devices.
- LED lamps are standard to provide longer life.

Certifications and Compliances:

- NEMA: 3, 4X, 7BCD and 12
- UL Standard: 508
- CSA C22.2 No. 14 & 30

Size Ranges:

- 1, 2, 3 and 4-device units

Electrical Rating Ranges:

- Pushbutton stations and selector switches – heavy duty 600VAC maximum
- Pilot lights – 120 to 600 VAC

Options:

Description

Padlock attachments for all pushbuttons. For "START-STOP" stations,

only "STOP" button provided with lockout..... **S708**

Three-position selector switches with modified operation:

Momentary contact clockwise operation, spring return to center, maintained contact counterclockwise operation..... **S634**

Momentary contact counterclockwise operation, spring return to center, maintained contact clockwise operation..... **S635**

Note: In addition to hub arrangements shown, the following can be obtained by inserting these codes for the 4th and 5th character in the catalog number:

- D = Double 1/2" hubs at bottom
- CD = Single hub at top, double 1/2" hubs at bottom
- DD = Double 1/2" hubs at each end

Dimensions In Inches:

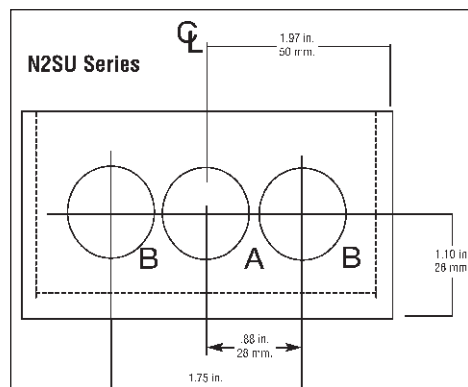
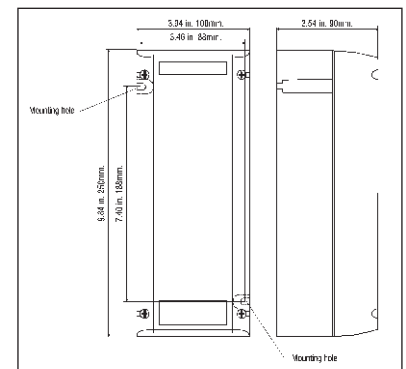
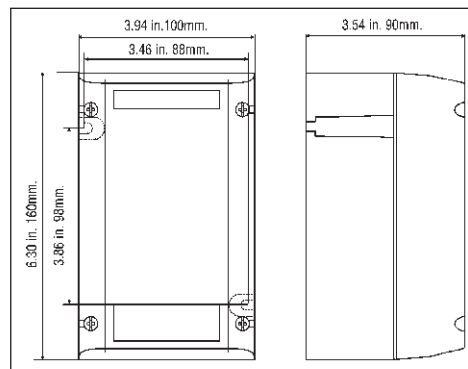

Entry	Note
A	.87 in. 22 mm. diameter for 1/2" single entry 1.09 in. 28 mm. diameter for 3/4" single entry
B	.87 in. 22 mm. diameter for 1/2" double entry

4C N2SU/N2SCU Control Stations

**Factory Sealed, Corrosion-Resistant
600VAC Heavy Duty**

Cl. I, Div. 2, Groups B, C, D
Corrosion-Resistant
Dust-tight
Watertight
Weatherproof
NEMA 3, 4X, 7BCD (Div. 2), 12

Cl. II, Div. 2, Groups F, G
Cl. I, Zones 1 and 2, Ex de IIB + H₂
IP66

Ordering Information - With Pushbuttons – Momentary Contact

No. Units	Contact Symbol	Marking Unless Otherwise Specified	Enclosure with Pushbuttons		
			Hub Size	Dead End Cat. #	Through Feed Cat. #
1		START (or Specify)	1/2 3/4	N2S1110U ② N2S2110U ②	N2SC1110U ② N2SC2110U ②
2		START-STOP (or Specify)	1/2 3/4	N2S1210U ② N2S2210U ②	N2SC1210U ② N2SC2210U ②
3		Specify	1/2 3/4	N2S1310U ② N2S2310U ②	N2SC1310U ② N2SC2310U ②
4		Specify	1/2 3/4	N2S1410U ② N2S2410U ②	N2SC1410U ② N2SC2410U ②



Maintained pushbutton with pilot light control station

Ordering Information - With Selector Switches*

Style	Position			Marking Unless Otherwise Specified	Enclosure with One Selector Switch		
	1	2	3		Hub Size	Dead End Cat. #	Through Feed Cat. #
Two-Position, Two-Circuit	A1			START-STOP (or Specify)	1/2 3/4	N2S1121U ② N2S2121U ②	N2SC1121U ② N2SC2121U ②
Two-Position, Four-Circuit	A1			START-STOP (or Specify)	1/2 3/4	N2S1122U ② N2S2122U ②	N2SC1122U ② N2SC2122U ②
Three-Position, Two-Circuit	A1			Specify	1/2 3/4	N2S1123U ② N2S2123U ②	N2SC1123U ② N2SC2123U ②
Three-Position, Four-Circuit	A1			Specify	1/2 3/4	N2S1124U ② N2S2124U ②	N2SC1124U ② N2SC2124U ②
Three-Position, Four-Circuit	A1			Specify	1/2 3/4	N2S1125U ② N2S2125U ②	N2SC1125U ② N2SC2125U ②

② If desired, markings on indicating plates may be added to catalog number. Select from the list of standard markings below:

Marking

Push Buttons:
START
STOP
ON
OFF
RUN
JOG
TRIP
RESET
TEST
LIGHT ON
HAND
AUTOMATIC
EMERGENCY
FORWARD

REVERSE
OPEN
CLOSE
UP
DOWN
IN
OUT
RAISE
LOWER

Selector Switches –
Two-Position:
RUN-JOG
HAND-AUTO
FOR-REV
FAST-SLOW
OPEN-CLOSE
UP-DOWN
ON-OFF
IN-OUT
RAISE-LOWER
START-STOP

Selector Switches –
Three-Position
RUN-OFF-JOG
HAND-OFF-AUTO
FOR-OFF-REV
FAST-OFF-SLOW
1-OFF-2
OPEN-OFF-CLOSE
UP-OFF-DOWN



CHS Controls AB
 Florettgatan 33
 SE-254 67 Helsingborg, Sweden
 Tel +46 42 38 61 00, Fax +46 42 38 61 29
 chs@chscontrols.se
 www.chscontrols.se

*Replacement switch for selector switches is Cat. No. ESWP126.

N2SU/N2SCU Control Stations

**Factory Sealed, Corrosion-Resistant
600VAC Heavy Duty**

Cl. I, Div. 2, Groups B, C, D
Corrosion-Resistant
Dust-tight
Watertight
Weatherproof
NEMA 3, 4X, 7BCD (Div. 2), 12

Cl. II, Div. 2, Groups F, G
Cl. I, Zones 1 and 2, Ex de IIB + H₂
IP66

4C

Ordering Information - With Pilot Lights - Transformer Type

No. Units	Diagram	Volts	Enclosure with Pilot Lights†			
			1/2" Hubs		3/4" Hubs	
			Dead End Cat. #	Through Feed Cat. #	Dead End Cat. #	Through Feed Cat. #
1		120	N2S1131U ①	N2SC1131U ①	N2S2131U ①	N2SC2131U ①
		240	N2S1132U ①	N2SC1132U ①	N2S2132U ①	N2SC2132U ①
2		120	N2S1231U ①	N2SC1231U ①	N2S2231U ①	N2SC2231U ①
		240	N2S1232U ①	N2SC1232U ①	N2S2232U ①	N2SC2232U ①
3		120	N2S1331U ①	N2SC1331U ①	N2S2331U ①	N2SC2331U ①
		240	N2S1332U ①	N2SC1332U ①	N2S2332U ①	N2SC2332U ①
4		120	N2S1431U ①	N2SC1431U ①	N2S2431U ①	N2SC2431U ①
		240	N2S1432U ①	N2SC1432U ①	N2S2432U ①	N2SC2432U ①

① Specify lens color for each pilot light. As an example, N2S1231U with one red and one green would be ordered as N2S1231U-J1-J3

Color	Symbol	Color	Symbol
Red	J1	Clear	J10
Green	J3	Blue	J11
Amber	J6		

†Pilot lights are transformer type except those rated 120 volts.

4C



CHS Controls AB
 Florettgatan 33
 SE-254 67 Helsingborg, Sweden
 Tel +46 42 38 61 00, Fax +46 42 38 61 29
 chs@chscontrols.se
 www.chscontrols.se

4C N2SU/N2SCU Control Stations

**Factory Sealed, Corrosion-Resistant
600VAC Heavy Duty**

Cl. I, Div. 2, Groups B, C, D
Corrosion-Resistant
Dust-tight
Watertight
Weatherproof
NEMA 3, 4X, 7BCD (Div. 2), 12

Cl. II, Div. 2, Groups F, G
Cl. I, Zones 1 and 2, Ex de IIB + H₂
IP66

Ordering Information - Combination Control Stations†*

Pilot Lights*	Pushbuttons	Diagram	Marking Unless Otherwise Specified	Volts	Enclosure with Push Buttons and Pilot Lights†			
					1/2" Hubs		3/4" Hubs	
					Dead End Cat. #	Through Feed Cat. #	Dead End Cat. #	Through Feed Cat. #
1	1		Specify	120	N2S12411U ①②	N2SC12411U ①②	N2S22411U ①②	N2SC22411U ①②
				240	N2S12412U ①②	N2SC12412U ①②	N2S22412U ①②	N2SC22412U ①②
1	2		START-STOP (or Specify)	120	N2S13421U ①②	N2SC13421U ①②	N2S23421U ①	N2SC23421U ①②
				240	N2S13422U ①②	N2SC13422U ①②	N2S23422U ①	N2SC23422U ①②
2	1		Specify	120	N2S13411U ①②	N2SC13411U ①②	N2S23411U ①②	N2SC23411U ①②
				240	N2S13412U ①②	N2SC13412U ①②	N2S23412U ①②	N2SC23412U ①②
2	2		START-STOP (or Specify)	120	N2S14421U ①②	N2SC14421U ①②	N2S24421U ①②	N2SC24421U ①②
				240	N2S14422U ①②	N2SC14422U ①②	N2S24422U ①②	N2SC24422U ①②

Pilot Lights*	Pushbuttons	Selector Switches Position No.			Markings	Enclosure With Pilot Light, Pushbuttons and Selector Switch			
		1	2	3		Hub Size in.	Volts	Dead End Cat. #	Through Feed Cat. #
1	2	Two-Position, Two-Circuit			Specify	1/2	120	N2S145211U ①②	N2SC145211U ①②
						3/4		N2S245211U ①②	N2SC245211U ①②
1	2	Three-Position, Two-Circuit			Specify	1/2	120	N2S145231U ①②	N2SC145231U ①②
						3/4		N2S245231U ①②	N2SC245231U ①②
1	2				Specify	1/2	240	N2S145232U ①②	N2SC145232U ①②
						3/4		N2S245232U ①②	N2SC245232U ①②

① Specify lens color for each pilot light. As an example, N2S1231U with one red and one green would be ordered as N2S1231U-J1-J3

Color	Symbol	Color	Symbol
Red	J1	Clear	J10
Green	J3	Blue	J11
Amber	J6		

② If desired, markings on indicating plates may be added to catalog number. Select from the list of standard markings below:

Marking		Selector Switches – Two-Position:		Selector Switches – Three-Position:	
Push Buttons:		Two-Position:		Three-Position:	
START	FORWARD	Two-Position:	RUN-JOG	Three-Position:	RUN-OFF-JOG
STOP	REVERSE	Two-Position:	HAND-AUTO	Three-Position:	HAND-OFF-AUTO
ON	OPEN	Two-Position:	FOR-REV	Three-Position:	FOR-OFF-REV
OFF	CLOSE	Two-Position:	FAST-SLOW	Three-Position:	FAST-OFF-SLOW
RUN	UP	Two-Position:	OPEN-CLOSE	Three-Position:	1-OFF-2
JOG	DOWN	Two-Position:	UP-DOWN	Three-Position:	OPEN-OFF-CLOSE
TRIP	IN	Two-Position:	ON-OFF	Three-Position:	UP-OFF-DOWN
RESET	OUT	Two-Position:	IN-OUT		
TEST	RAISE	Two-Position:	RAISE-LOWER		
LIGHT ON	LOWER	Two-Position:	START-STOP		
HAND					
AUTOMATIC					
EMERGENCY					

CHS Controls AB
 Florettgatan 33
 SE-254 67 Helsingborg, Sweden
 Tel +46 42 38 61 00, Fax +46 42 38 61 29
 chs@chscontrols.se
 www.chscontrols.se



*Replacement switch for selector switches is Cat. No. ESWP126.
 †Pilot lights are transformer type except those rated 120 volts.

Factory Sealed, Corrosion-Resistant

Applications:

N2FA and N2FAC fire alarm stations are used:

- As break-glass fire alarm stations
- In conjunction with audible and/or visible signaling devices to alert personnel of a fire hazard
- In Class I, Division 2, Groups B, C, D hazardous areas where flammable vapors or gases may be present due to an accident or abnormal operation
- In damp, wet or corrosive locations
- Indoors or outdoors in Division 2 areas of petroleum refineries, chemical plants and other process industry facilities where similar hazards exist

Features:

- Factory sealed. External seals are not required.
- Enclosures are made of *Krydon*[®] fiberglass-reinforced polyester material having excellent corrosion resistance and stability to heat and sunlight.
- Highly visible molded-in red color for quick identification.
- Break-glass rod is attached to station with a chain for ready access during an emergency.
- Factory installed dead end (N2FA) or through feed (N2FAC) hubs – 1/2", 3/4" and 1" sizes.

Certifications and Complies:

- NEC:
 Class I, Division 2, Groups B, C, D
- NEMA 3, 7BCD (Division 2), 12



Ordering Information

Hub Size	Dead End Cat. #	Through Feed Cat. #	Replacement Glass Cat. #
1/2	N2FA11	N2FAC11	DS K14
3/4	N2FA21	N2FAC21	DS K14
1	N2FA31	N2FAC31	DS K14

Dimensions* In Inches:

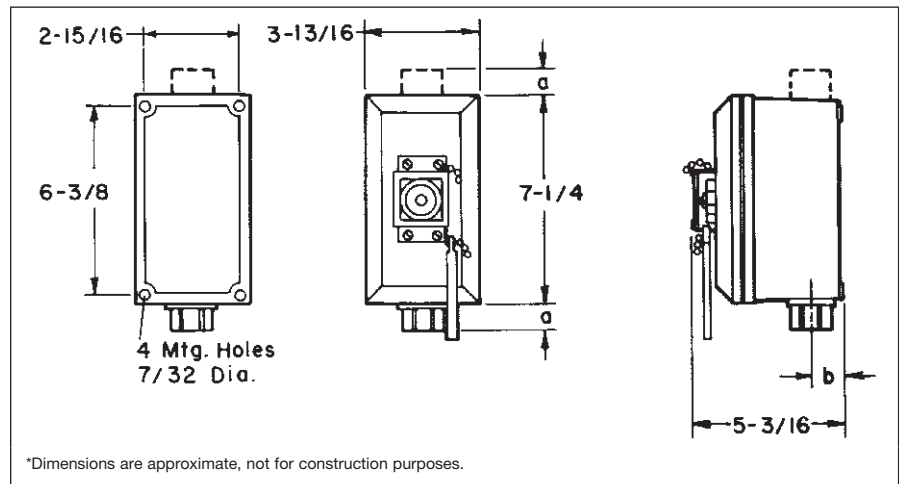

1/2" & 3/4" Hubs		1" Hubs	
a	b	a	b
1 1/8	1 1/16	1 1/4	1 1/16



CHS Controls AB
 Florettgatan 33
 SE-254 67 Helsingborg, Sweden
 Tel +46 42 38 61 00, Fax +46 42 38 61 29
 chs@chscontrols.se
 www.chscontrols.se

4C GHG43 Series Control Stations

Nonmetallic or 316L Stainless Steel Corrosion Resistant

UL/cUL listed
 Cl. I, Div. 2, Groups A, B, C, D
 Cl. I, Zones 1 and 2,
 (A) Ex de IIB + H₂ T6
 Cl. II, Div. 1, Groups E, F, G (cUL)

PTB ATEX CERTIFIED 3117
 Ex de IIC, T6,
 Zones 1 and 2
 Ex de IIC, T6 Zones 21 and 22
 IP 66, NEMA 4X

Applications:

Control stations are used as a remote means of:

- Motor control
- Visual indication of equipment performance
- On-off control of circuits
- Circuit selection

Common applications include:

- Areas which are hazardous due to the presence of flammable vapors, gases or highly combustible dusts
- For installation at petroleum refineries, chemical and petrochemical plants and other process industry facilities where similar hazards exist

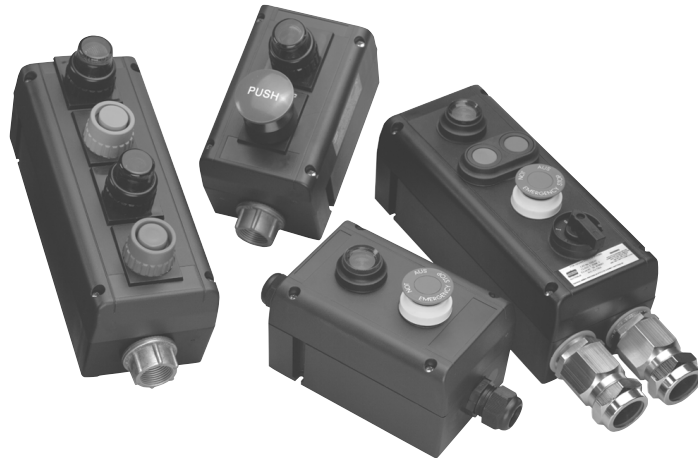

GHG43 Nonmetallic Control Stations

Features:

- NEMA 4X, IP66 enclosure with formed-in-place gasket
- Available with all operators: indicator lights, potentiometers, control switches, pushbuttons, terminal blocks and meters
- Base-mounted contact blocks
- Easy change-out components snap in place on DIN rail
- Enclosure meets UL 94-VO. Also available in anti-static Ex e materials
- Inserts for mounting DIN rails
- Available with a maximum of 2 entries - top and bottom for conduit fittings or cable glands
- Suitable for universal mounting plates on pipes, conduit, wall or channels
- Mounting dimensions data molded on back
- Captive, corrosion-resistant cover screws
- Built-in mounting slots for wall installation
- Available in 316L stainless steel

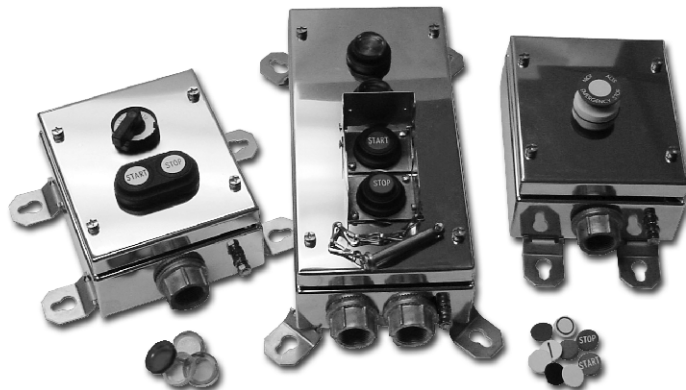

GHG43 Stainless Steel Control Stations

Certifications and Compliances:

- UL/cUL Listed
- Class I, Div. 2, Groups A, B, C, D
- Class II, Div. 1, Groups E, F, G (cUL)
- Class I, Zones 1 and 2, Ex de IIB + H₂, T6
- AEx de IIB + H₂, T6
- Type 3, 4, 4X; IP66
- CENELEC-PTB 00 ATEX 3117
- Ex de IIC, T6, Zones 1 and 2, IP66

Options:

Description	Suffix
Cooper Crouse-Hinds GHG43 Series control stations are now available with 316L stainless steel enclosures, making them ideal for corrosive and adverse locations - especially offshore platform applications.	S860



Nonmetallic or 316L Stainless Steel Corrosion Resistant

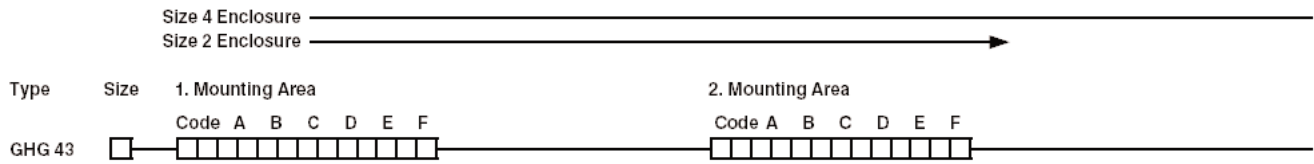

GHG43 2 - Size 2 Enclosure

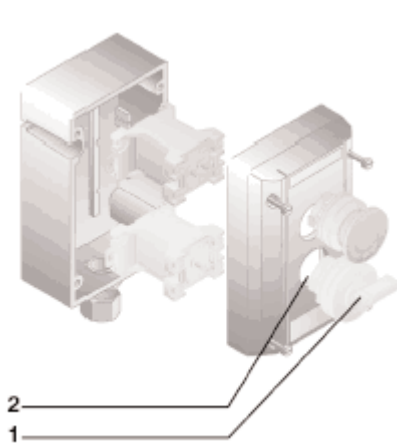

Mounting Area*



Pushbutton DRT

Code A B C D

Codes see page 545



Double Pushbutton

Code A B C D E

Codes see page 545

GHG43 4 - Size 4 Enclosure

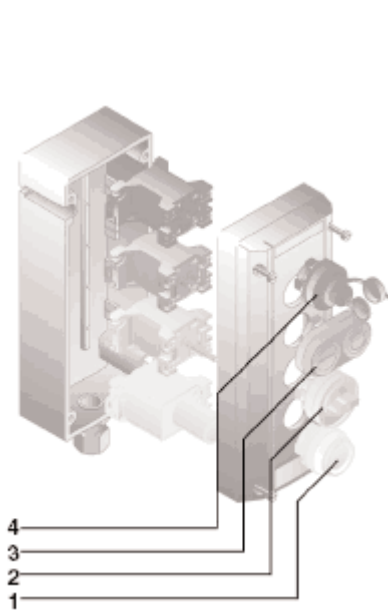

Mounting Area*



Key Operated Pushbutton

Code A B C

Codes see page 545



Mushroom-Head Pushbutton

Code A B C D E F

Codes see page 546



Signal Lamp

Code A B C

Codes see page 546

‡For a GHG43 control station with 316L stainless steel enclosure, add suffix "S860" to end of catalog number.
*Unoccupied spaces must be filled in with KLM for correct positioning of devices.

CHS Controls AB
Tel +46 42 38 61 00, Fax +46 42 38 61 29
chs@chscontrols.se www.chscontrols.se

**Nonmetallic or 316L Stainless
Steel Corrosion Resistant**

3. Mounting Area

Code A B C D E F

4. Mounting Area

Code A B C D E F

Cable Entries

Top Bottom



Potentiometer

Code A B

Codes see page 547



Measuring Instrument

Code A B C

Codes see page 548
Requires 2 spaces



Switch

Code A B C D

Codes see pages 549–550



Control Switch Ex 23 10A

Code A B C D E F

Codes see pages 549–550
Requires 2 spaces

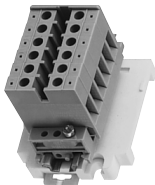

Terminals and cover
blanking plug

Code A B

Code see page 547

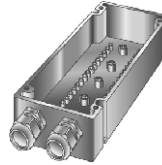

Two entries

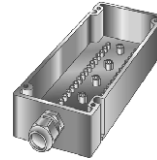

One entry

Cable Entries

NPT

No entries

2 x 1/2" Myers Hub,
STGK1 Zinc Gland
plate

2 x 3/4" Myers Hub,
STGK2 Zinc Gland
plate
(Stainless Steel
Control Stations only)

2 x 1/2" Myers Hub,
SSTGK1 Stainless
steel
Gland plate

2 x 3/4" Myers Hub,
SSTGK2 Stainless
steel
Gland plate
(Stainless Steel
Control Stations only)

1 x 3/4" Myers Hub,
STGK2, Zone 1
Gland plate

1 x 1/2" Myers Hub,
STGK1, Zone 1
Gland plate

1 x 1/2" Myers Hub,
SSTGK1 Stainless st.
Gland plate

1 x 3/4" Myers Hub,
SSTGK2 Stainless st.
Gland plate

Metric

No entries

2 x M25 Plastic
Cable gland M25
Blanking plug

2 x M20
Threaded entries
Gland plate

2 x M25
Threaded entries
Gland plate

1 x M32 Plastic
Cable gland

1 x M25
Threaded Entry,
Blanking plug and
Gland plate

2 x M25
Threaded Entry,
1 blanking plug and
Gland plate

1 x M20
Threaded entry
Blanking plug and
Gland plate

1 x 3/4" Myers Hub
SSTGK2 stainless
steel,
Gland plate



CHS Controls AB

Tel +46 42 38 61 00, Fax +46 42 38 61 29
chs@chscontrols.se www.chscontrols.se

‡For a GHG43 control station with 316L stainless steel enclosure, add suffix "S860" to end of catalog number.
*Unoccupied spaces must be filled in with KLM for correct positioning of devices.

Nonmetallic or 316L Stainless Steel Corrosion Resistant



CHS Controls AB
 Tel +46 42 38 61 00, Fax +46 42 38 61 29
 chs@chscontrols.se www.chscontrols.se

Pushbuttons:

- Used for logic controls in hazardous areas
- Single or double units
- Used with all operators
- Base mounting



Type of Protection

Certificate of Conformity

Approvals

Rated Voltage

Rated Current

Terminal Wiring

Mechanical and Electrical Life

Pushbutton

Ex de IIC T6
 PTB No. Ex-87.B.1007U
 PTB, UL, cUL
 Up to 400V
 NEC/CEC 10A IEC 16 A
 2 x 2.5mm² / 14AWG
 >10⁶ Operations

See page 550 for explanation of contact symbols.

Pushbutton DRT

	D	R	T	O				
Code	A				B	C	D	
Contact System	12 22 11 21		14 24 13 23		14 22 13 21			
Code B	13		14		15			
Inscription	ALL *	0	I	II	Stop	Start	Special-Text On Order †	
Code C	01	02	03	04	06	07	99	

Lockout see page 551

Code D (leave blank if no lockout required)

Double Pushbutton DDTO

	D	D	T	O		Left	Right	E
Code	A				B	C	D	E
Contact System	12 22 11 21		14 24 13 23		14 22 13 21			
Code B	43		44		45			
Inscription	ALL *	0	I	II	Stop	Start	Special-Text on Order †	
Code C, D Left/Right	01	02	03	04	06	07	99	

Lockout see page 551

Code E (leave blank if no lockout required)

Key-Operated Pushbutton SLT

	S	L	T	O			
Code	A			B	C		
Contact System	12 22 11 21		14 24 13 23		14 22 13 21		
Code B	23		24		25		
Pushbutton	Key						
Not Depressed	Lockable	Yes	Yes	Yes	No	No	Yes
	Key Removable	Yes	Yes	No	No	Yes	Yes
Depressed	Lockable	Yes	No	Yes	Yes	Auto	Yes
	Key Removable	No	No	Yes	Yes	Yes	Yes
Code C	1		2		3		4 5 6

* 01 - Includes the following discs - Start, stop, I, O, and red, green, yellow, white and black blank discs.

† For Marking Guide for Pushbuttons see page 551.

Nonmetallic or 316L Stainless Steel
Corrosion Resistant



Mushroom-Head Pushbutton SGT

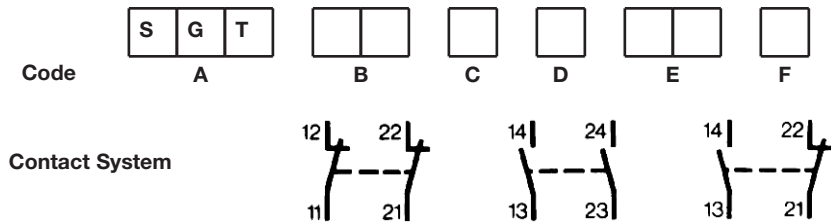

Code	A	B	C	D	E	F
Contact System						
Code B	53	54	55			
Color of Pushbutton	Red	Yellow	Black Actuator			
Code C	1	2	3			
Function	Spring Return	Maintained	Key Release			
Code D	1	2	3			
Inscription	Stop	Start	Black Actuator			
Code E	06	07	11			

Lockout
see page 551

Code F (leave blank if no lockout required)

Signal Lamp

- Used for positive feedback indication
- High intensity with special reflector and optical lens
- Accommodates most input voltages
- Base mounting



Type of Protection	Ex de IIC T6
Certificate of Conformity	PTB No. Ex-88.B.2106U
Approvals	PTB, UL, cUL
Lamp Life	>100,000 Hours (11.5 Years) Up to 240VAC, 50 / 60 Hz
Rated Voltages	Up to 110VDC
Rated Current	Max. 15 mA
Power Consumption	<1.2W
Terminal Wiring	2 x 2.5mm ² / 14AWG
Colors	Red, Green, Yellow, Clear & Blue

Signal Lamp SIL



Code	A	B	C	1 pkg white, yellow, red, green	Green	Blue
Colored Lens Cover	White	Yellow	Red			
Code B	1	2	3	4	5	6
Voltage		20-250VAC/DC		10-33VAC/DC		
Code C		01		31		



CHS Controls AB
 Florettgatan 33
 SE-254 67 Helsingborg, Sweden
 Tel +46 42 38 61 00, Fax +46 42 38 61 29
 chs@chscontrols.se
 www.chscontrols.se

Nonmetallic or 316L Stainless Steel Corrosion Resistant

Terminal Blocks

- Terminal block for easy field connections
- Base mounting

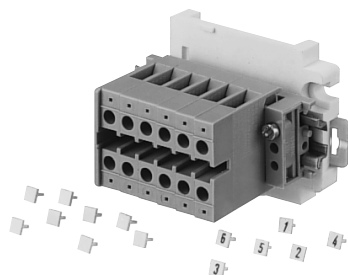

Type of Protection
Certificate of Conformity
Rated Voltages
Rated Current
Conductor Size

Terminal Blocks

Ex e II
PTB No. Ex-88.B.3112U
Up to 400V
23A
4mm² / 12AWG

Terminals and Cover Plugs KLM



	6 Terminals 2 x 4 mm²	Undrilled Cover (No Terminals)
Code B	61	00

Potentiometers

- Used to adjust resistance to vary motor speed or light levels
- Scale 0 to 100%
- Base mounting



Type of Protection
Certificate of Conformity
Approvals
Rated Voltages
Power Consumption
Resistance
Angle of Rotation
Scale
Connection Terminals

Potentiometers

Ex de IIC T6
PTB No. Ex-87.B.1007U
PTB, UL, cUL
>250V
1.0W
100–10,000W
270°
0–100%
2 x 2.5mm² / 14AWG

Potentiometer POT

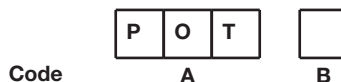

Power Consumption	1W			
Resistance W	1,000	2,200	4,700	10,000
Code B	4	7	5	6



CHS Controls AB
 Florettgatan 33
 SE-254 67 Helsingborg, Sweden
 Tel +46 42 38 61 00, Fax +46 42 38 61 29
 chs@chscontrols.se
 www.chscontrols.se

**Nonmetallic or 316L Stainless Steel
Corrosion Resistant**

Ammeters

- Used to measure motor current draw for efficiencies and maintenance
- Slide in scales to accommodate any amperage range
- Red indicator for quick visual indication to compare set points and actual values



Ammeters	
Type of Protection	Ex e II T6
Certificate of Conformity	PTB No. Ex-87.B.2016U
Approvals	PTB, UL, cUL
Movement	Moving iron (core)
Accuracy	2.5% of range (class 2.5)
Measuring Range	0-16A direct, C.T. n/1 A
Operating Position	Vertical
Scale	Interchangeable for C.T. n/1 A
Zero Adjustment	At instrument
Terminal Wiring	2 x 2.5 mm ² / 14 AWG
Rated Current Marking	Red indicator

**Ammeter Measuring
Instrument AM 72***



Code A B C

Movement	Direct	n/1 A	0 - 2 mA	4-20 mA
Code B	1	2	3	6

Movements 0-20 mA and 4-20 mA are only available with 0 - 100 / 120% scale

Direct Measurement		Interchangeable Scale for C.T. n/1A					
Code C	Scale	Code C	Scale	Code C	Scale	Code C	Scale
02	0 -1/1.5A	02	0 -1/1.5A	09	0 - 30/45A	16	0 - 200/300A
03	0 - 2.5/3.75A	03	0 - 2.5/3.75A	10	0 - 40/60A	17	0 - 250/375A
04	0 -5/7.5A	04	0 -5/7.5A	11	0 - 50/75A	18	0 - 300/450A
05	0 - 10/15A	05	0 - 10/15A	12	0 - 60/90A	19	0 - 400/600A
07	0 - 16/24A	06	0 -15/22.5A	13	0 -75/112.5A	20	0 - 500/750A
		08	0 - 20/30A	14	0 - 100/150A	21	0 - 600/900A
				15	0 - 150/225A	22	0 - 100/150A

* Requires 2 spaces.



CHS Controls AB
 Florettgatan 33
 SE-254 67 Helsingborg, Sweden
 Tel +46 42 38 61 00, Fax +46 42 38 61 29
chs@chscontrols.se
www.chscontrols.se

**Nonmetallic or 316L Stainless Steel
Corrosion Resistant**



CHS Controls AB
Tel +46 42 38 61 00, Fax +46 42 38 61 29
chs@chscontrols.se www.chscontrols.se

Rotary Control Switches

- Used for selectable operations (i.e. Hand-Off-Auto)
- 2 independent contacts
- Available in any contact configuration
- Spring return or maintained position
- Available with lockout positions



	SCT	Ex 23
Type of Protection	Ex de IIC T6	Ex de IIC T6
Certificate of Conformity	Ex.87.B.1007U	PTB no. Ex-88.B.1047U
Approvals	PTB, UL, cUL	PTB, UL, cUL
Rated Voltage	400 V	Up to 500 V
Rated Current	NEC 10 A IEC 16 A	NEC 10 A IEC 16 A
Terminal Wiring	2 x 2.5mm ² / 14 AWG	2 x 2.5mm ² / 14 AWG
Mechanical Life	>10 ⁵ Operations	>10 ⁵ Operations
Electrical Life	>10 ⁵ Operations	>10 ⁵ Operations
Switching Capacity	AC I: 20V/6A 400V/4A DC II: 24V/6A 60V/0.8A 110V/.5A 220V/.2A	AC I: 500G/10A AC II: 230V/6A 500V/6A DC II: 24V/6A 48V/4A 60V/0.8A 110V/0.5A 220V/0.4A

Rotary Control Switch SCT

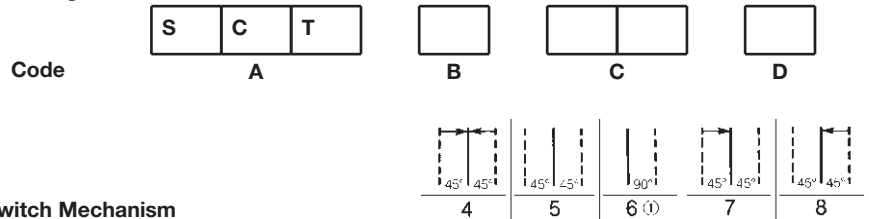

Code B	Inscription	Code C	Inscription			
01	0	I	07	I	0	II
03	STOP	START	13	LOCAL	REMOTE	AUTO
04	HAND	AUTO	14	STOP	0	START
06	REMOTE	LOCAL	15	HAND	0	AUTO
29	OFF	ON	99	Special – text to be given on order		

Same as SCT above except up to 4 independent contacts

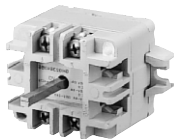

Rotary Control Switch Ex 23*

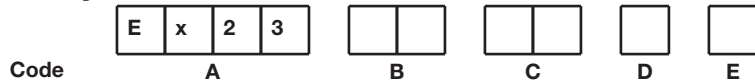

Code B	Inscription
01	0
03	STOP
04	HAND
06	remote
07	I
13	LOCAL
14	STOP
23	OFF
24	HAND
27	START
29	OFF
32	ON
99	Special – text to be given on order

I	START	
AUTO	AUTO	
local	local	
0	0	
REMOTE	REMOTE	AUTO
0	0	START
0	0	ON
OFF	OFF	AUTO
STOP	STOP	
ON	ON	
OFF	OFF	

* Requires 2 spaces in cover.

Nonmetallic or 316L Stainless Steel
Corrosion Resistant

4C

Code C	Contact System	Type	Code C	Contact System	Type
00		2 Position	09		3 Position
01		2 Position	10		3 Position
02		2 Position	12		3 Position
03		Single Pole Changeover	13		2 Position
05		HOA	14		2 Position
07		3 Position Single Level	15		3 Position Double Pole Changeover

Switched Mechanism
Code D

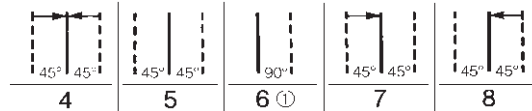

Padlocking Facility
Code E



Contact Configurations

Normally Closed			Normally Open
Normally Closed Extended Over 2 Positions			Normally Open Early Make/Late Break
Change-Over Break Before Make			Change-Over Make Before Break

Example of Switch Type 10

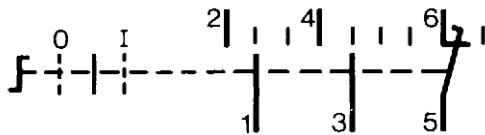

This example is the switch type 10 Stop-Run-Stop. The switch has 3 positions – the normal position is center and can be switched left or right. An arrow (→←) indicates spring return. (See codes for switch mechanism). Contacts 1-2 only close in the Stop position. Contacts 3-4 close only in the Start position. Contacts 5-6 are normally closed and remain closed when switched to the Start position and open when switched to the Stop position.



CHS Controls AB
 Florettgatan 33
 SE-254 67 Helsingborg, Sweden
 Tel +46 42 38 61 00, Fax +46 42 38 61 29
 chs@chscontrols.se
 www.chscontrols.se

Nonmetallic or 316L Stainless Steel Corrosion Resistant

Lockouts for DRTO Pushbuttons



X
Code D
Shroud Cover For
Pushbutton
Y-Lockout with bolt and chain



Z
Code D
Padlocking Fire Alarm
Cover For Pushbutton

Lockouts for DDTO Double Pushbuttons



X
Code ED
Padlocking Cover For
Double Pushbutton
Without Hole



Z
Code E
Padlocking Cover For
Double Pushbutton
With Hole

Lockouts for SGT Mushroom-Head Pushbuttons



X
Code F
Padlocking Cover For
Emergency Stop Pushbutton



Z
Code F
Padlocking Cover For
Emergency Stop Pushbutton
With Bolt & Chain

Marking Guide For Pushbuttons

Special Text

Marking Required	Standard Abbreviation	Actual Marking on Disc
Acknowledge	AK	ACK
Alarm	AM	ALARM
Automatic	AU	AUTO
Close	CL	CLOSE
Down	DN	DOWN
Fast	FS	FAST
Forward	FW	FWD
Hand	HN	HAND
High	HI	HIGH
In	IN	IN
Jog	JG	JOG
Local	LC	LOCAL
Lower	LO	LOWER
Maintain	MT	MAINT
Manual	MN	MANUAL
Normal	NR	NORMAL
Off	OF	OFF
On	ON	ON
Open	OP	OPEN
Out	OT	OUT
Raise	RA	RAISE
Remote	RM	REMOTE
Reset	RS	RESET
Reverse	RV	REV
Run	RN	RUN
Slow	SL	SLOW
Test	TT	TEST
Trip	TP	TRIP
Up	UP	UP



CHS Controls AB
 Florettgatan 33
 SE-254 67 Helsingborg, Sweden
 Tel +46 42 38 61 00, Fax +46 42 38 61 29
chs@chscontrols.se
www.chscontrols.se

**Nonmetallic or 316L Stainless Steel
Corrosion Resistant**



CHS Controls AB
 Florettgatan 33
 SE-254 67 Helsingborg, Sweden
 Tel +46 42 38 61 00, Fax +46 42 38 61 29
 chs@chscontrols.se
 www.chscontrols.se

GHG43 Nonmetallic Control Stations

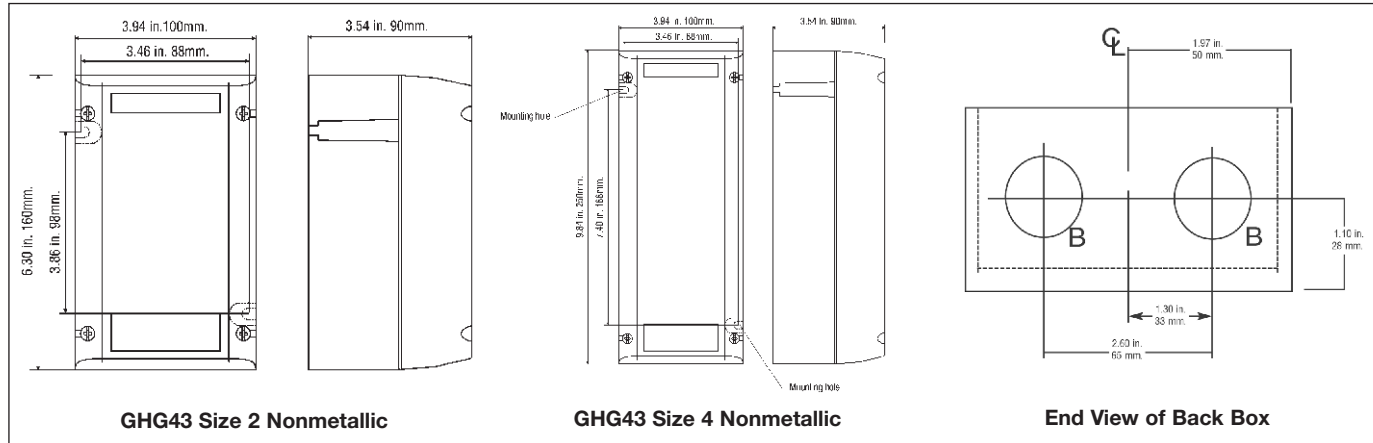

GHG43 Size 2 Nonmetallic

GHG43 Size 4 Nonmetallic

End View of Back Box

GHG43 Stainless Steel Control Stations

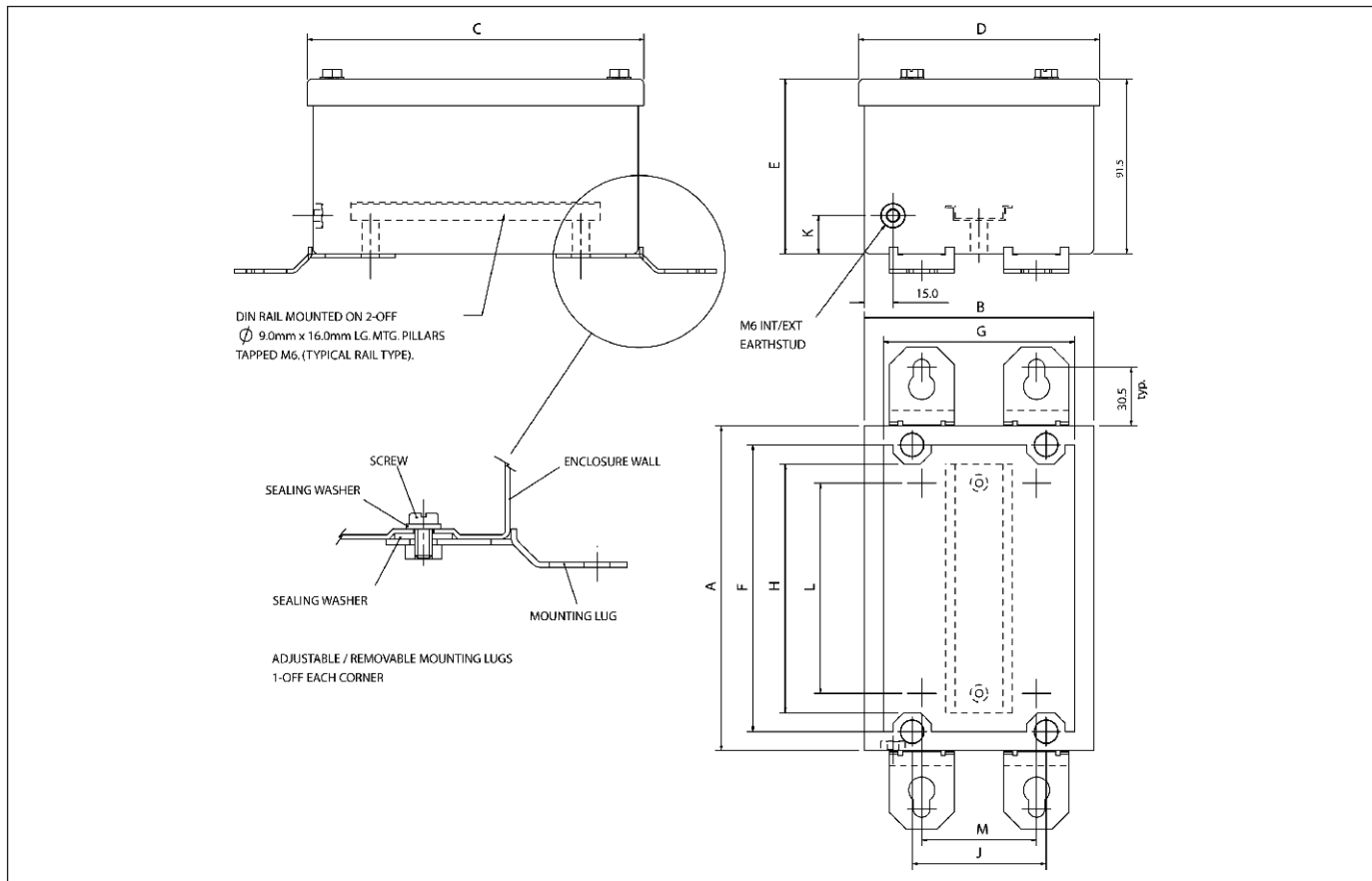

Box Type

Dimension (inches)

	A	B	C	D	E	F	G	H	J	K	L	M
1 Operator Control Station	4.72	4.72	4.96	4.96	3.60	3.94	3.94	3.15	2.76	0.79	2.36	2.36
2 Operator Control Station	6.69	4.72	6.93	4.96	3.60	5.90	3.94	5.12	2.76	0.79	4.33	2.36
3 Operator Control Station	8.66	4.72	8.90	4.96	3.60	7.87	3.94	7.09	2.76	0.79	6.30	2.36
4 Operator Control Station	10.63	4.72	10.87	4.96	3.60	9.84	3.94	9.06	2.76	0.79	8.27	2.36

OAC Series Pushbutton Stations and Heavy Duty Selector Switches

**600 VAC Standard
Factory Sealed†**

Cl. I, Div. 1 & 2, Groups A, B, C, D
Cl. II, Div. 1, Groups E, F, G
Cl. II, Div. 2, Groups F, G
Cl. III
NEMA 3, 4, 7ABCD, 9EFG, 12

Explosionproof
Dust-Ignitionproof
Raintight
Wet Locations
Watertight

4C

Applications:

OAC Units are used:

- In areas which are hazardous due to the presence of flammable vapors, gases or highly combustible dusts
- In damp, wet or corrosive locations
- Indoors or outdoors at petroleum refineries, chemical and petrochemical plants and other process industry facilities where similar hazards exist
- In areas which are hazardous due to the presence of acetylene and hydrogen, or gases or vapors of equivalent hazard such as manufactured gas
- In conjunction with magnetic starters or contactors for remote control of motors

Features:

- Water-shedding construction with female threaded bottom opening and male threaded cover
- Threaded cover is deep dome type, which surrounds the enclosed device
- All enclosures are suitable for hazardous area use
- Pushbutton stations have a guarded rocker type operating handle at the front arranged for padlocking to prevent unauthorized operation
- Selector switches have a lever type operating handle at the top
- Provided with vertical through feed conduit hubs of sizes indicated in the listings
- Units are factory sealed for Cl. I, Div. 1 and 2, Groups B, C, D
- Standard lockout on selector switches. Locks two or three-position switch handle in any position.

Standard Materials:

- Bodies – *Feraloy*® iron alloy
- Covers and operating handle – copper-free aluminum
- Operating shafts – stainless steel

Standard Finishes:

Feraloy iron alloy – electrogalvanized and aluminum acrylic paint

- Copper-free aluminum – natural
- Stainless steel – natural

Certifications and Complies:

- NEC/CEC
 - Class I, Division 1 & 2, Groups A, B, C, D
 - Class II, Division 1, Groups E, F, G
 - Class II, Division 2, Groups F, G
 - Class III
- NEMA/EEMAC: 3, 4, 7ABCD, 9EFG, 12
- UL Standard: 1203
- CSA Standard: C22.2 No. 30

Electrical Rating Ranges:

- Pushbutton stations, and selector switches - Air Break – heavy duty 600VAC maximum

Options:

The following special options are available from factory by adding suffix to Cat. #:

Description

Description	Suffix Specify
Back boss drilled and tapped for 3/4" and 1" sizes.....	
Three-position selector switches with modified operation:	
Momentary contact clockwise operation, spring return to center, maintained contact counter-clockwise operation.....	S634
Momentary contact counter-clockwise operation, spring return to center, maintained contact clockwise operation.....	S635



Dimensions In Inches*:

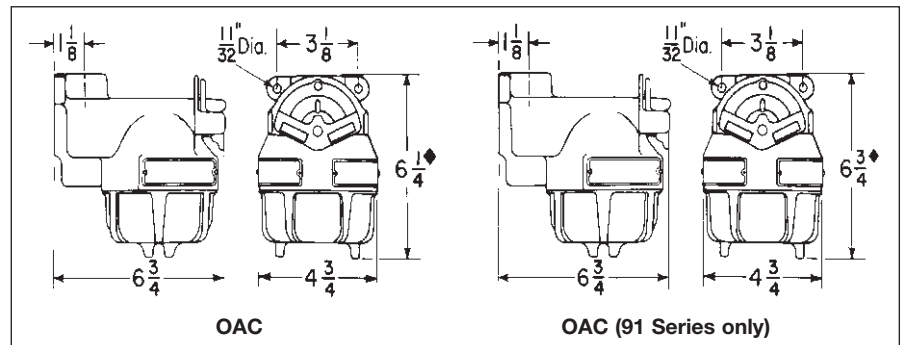

†Factory sealed for Class I, Div. 1 & 2, Groups B, C, D.

*Dimensions are approximate, not for construction purposes. For cover removal, add 2 1/2" to dimension.



CHS Controls AB
 Florettgatan 33
 SE-254 67 Helsingborg, Sweden
 Tel +46 42 38 61 00, Fax +46 42 38 61 29
 chs@chscontrols.se
 www.chscontrols.se

4C OAC Series Pushbutton Stations and Heavy Duty Selector Switches

**600 VAC Standard
Factory Sealed†**

Cl. I, Div. 1 & 2, Groups A, B, C, D Explosionproof
 Cl. II, Div. 1, Groups E, F, G Dust-Ignitionproof
 Cl. II, Div. 2, Groups F, G Raintight
 Cl. III Wet Locations
 NEMA 3, 4, 7ABCD, 9EFG, 12 Watertight



Ordering Information - Pushbutton Stations

Normal Pos.	1 Circuit Universal	2 Circuits Universal	2 Circuits Universal	2 Circuits*
Oper. Handles	Single	Double	Single Operating Both Buttons	Double
Replacement Pushbuttons Diagram	ED21	ED22	ED22	ED22*
Hub Size	Cat. #	Cat. #	Cat. #	Cat. #
3/4	OAC2101 ①	OAC2133 ①	OAC2139 ①	OAC2103 ①
1	OAC3101 ①	OAC3133 ①	OAC3139 ①	OAC3103 ①

With momentary left handle and maintained right handle. For momentary "START", maintained "STOP" and similar applications.

Normal Pos. Diagram	2 Circuit Universal

Enclosure with Pushbuttons Hub Size	Cat. #
3/4	OAC2291 ①
1	OAC3291 ①

① If desired, markings on indicating plates may be added to catalog number. Select from the list of standard markings below:

START	OFF	RESET	LIGHT ON
STOP	RUN	TRIP	HAND
ON	JOG	TEST	AUTOMATIC
EMERGENCY	OPEN	DOWN	RAISE
FORWARD	CLOSE	IN	LOWER
REVERSE	UP	OUT	

†Factory sealed for Class I, Div. 1 & 2, Groups B, C, D

*Two universal contact blocks, must be wired as two circuits, one normally open and one normally closed.



CHS Controls AB

Florettgatan 33
 SE-254 67 Helsingborg, Sweden
 Tel +46 42 38 61 00, Fax +46 42 38 61 29
 chs@chscontrols.se
 www.chscontrols.se

OAC Series Pushbutton Stations and Heavy Duty Selector Switches

**600 VAC Standard
Factory Sealed†**

Cl. I, Div. 1 & 2, Groups A, B, C, D
Cl. II, Div. 1, Groups E, F, G
Cl. II, Div. 2, Groups F, G
Cl. III
NEMA 3, 4, 7ABCD, 9EFG, 12

Explosionproof
Dust-Ignitionproof
Raintight
Wet Locations
Watertight

4C

Ordering Information - Selector Switches

Style	Position 1	Position 2	Position 3	Replacement Contact Blocks*	Enclosure with Selector Switch	
					Hub Size	Cat. #
Two-Position, Two-Circuit	A1			ED21	3/4 1	OAC2471 ① OAC3471 ①
	A2					
Two-Position, Four-Circuit	A1			ED22	3/4 1	OAC2472 ① OAC3472 ①
	A2					
	B1					
	B2					
Three-Position, Two-Circuit ‡	A1			ED21	3/4 1	OAC2473 ① OAC3473 ①
	A2					
Three-Position, Four-Circuit ‡	A1			ED22	3/4 1	OAC2474 ① OAC3474 ①
	A2					
	B1					



OAC Selector Switches are furnished with pushbutton contact blocks, cam actuated by a maintained contact selector mechanism to operate in the sequences shown in the diagrams below.

① If desired, markings on indicating plates may be added to catalog number. Select from the list of standard markings below:

Two-Position

RUN, JOG	FAST, SLOW	IN-OUT
HAND, AUTOMATIC	OPEN, CLOSE	RAISE-LOWER
FORWARD, REVERSE	UP, DOWN	START-STOP
	ON, OFF	

Three-Position

RUN, OFF, JOG	1, OFF, 2
HAND, OFF, AUTOMATIC	OPEN, OFF, CLOSE
FORWARD, OFF, REVERSE	UP, OFF, DOWN
FAST, OFF, SLOW	

Dimensions*

In Inches:

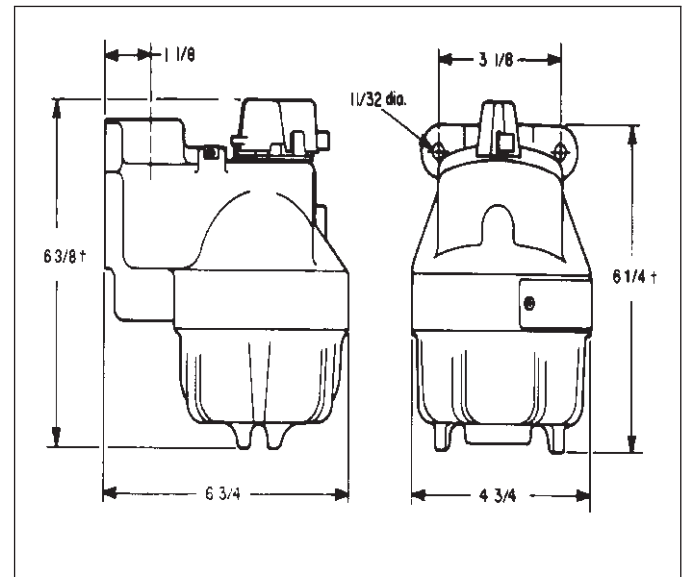

†Factory sealed for Class I, Div. 1 & 2, Groups B, C, D

‡ Suffixes S634 or S635 may be used on these catalog numbers. See page 553 for explanation of options.

*Dimensions are approximate. Not for construction purposes. For cover removal, add 2 1/2" to dimension.



CHS Controls AB

Florettgatan 33
SE-254 67 Helsingborg, Sweden
Tel +46 42 38 61 00, Fax +46 42 38 61 29
chs@chscontrols.se
www.chscontrols.se

Hinged and Open Front



CHS Controls AB

Florettgatan 33

SE-254 67 Helsingborg, Sweden

Tel +46 42 38 61 00, Fax +46 42 38 61 29

chs@chscontrols.se

www.chscontrols.se



Open Front Cover



Hinged Cover

Applications:

Added environmental protection for Cooper Crouse-Hinds control stations is now available from a patented "slip on" series of covers. Easy to install, these enclosures are available in hinged and open front styles, and are ideal for corrosive and adverse areas where product endurance is essential.

Secured Access Hinged Cover

- High moisture areas due to weather, steam, or wash down procedures.
- Areas where dirt, dust, mud, sand, etc. interferes with equipment operation.
- Prevention of accidental equipment operation.
- Instances requiring equipment lock out/tag out.

Quick Access Open Front Cover

- Areas requiring quick access to control device.
- Areas of high moisture from weather or dripping liquid.
- Prevention of accidental equipment operation.
- Areas with possible damage from bumping or banging.

Features and Benefits:

- Clear UV stabilized Lexan polycarbonate plastic allows the end-user to see enclosed controls and is strong enough to withstand the rough treatment found in the industrial work place.
- Downtime due to weather or accidental bumping is eliminated and plant shutdowns caused by inoperable or accidentally operated pushbutton devices are non-existent.
- Lock out/tag out capabilities conform to OSHA requirements and provides increased personnel safety.
- Quick and easy slip on installation requires no tools or interruption of service.
- Hinged cover provides superior sealing through heavy-duty neoprene gaskets.
- Colored covers are available (e.g. red for emergency, yellow for fire alarm, etc.).
- Specific chemical resistant covers available (may not be clear) - consult factory for minimum order quantity.
- Capability to engineer cover to fit any size device - consult factory.

Hinged Covers

Single Gang Application

EDS(C) and EFD(C) control stations
EFS(C) control stations
MC(C) control stations
FS(C) back box with cover assembly
FD(C) back box with cover assembly
EGF11 and EGF12 (Ground Fault)
N2S(C) Krydon: 1 & 2 devices
N2D(C) Krydon: 1 & 2 devices
GHG432 control station

Cat. #

NC CH1
NC CH1 EFS
NC CH1 MC
NC CH1 FS
NC CH1 FD
NC CH1 EGF 11
NC CH1 N2S
NC CH1 N2D
NC CH1 GHG

Single Gang (Long) Application

EFD(C) (3 device)
N2S(C) Krydon: 3 devices
N2S(C) Krydon: 4 devices

Cat. #

NC CH1 3L
NC CH1 N2S 3L
NC CH1 N2S 4L

Double Gang Application

EDS(C) control stations
EDSCM32: 2 gang tandem
EDSCM33: 3 gang tandem
FS(C) back box with cover
FD(C) back box with cover
EDSC378 - 3 gang tandem assembly

Cat. #

NC CH2
NC CH2L
NC CH3L
NC CH2 FS
NC CH2 FD
NC CH1 MC3

Open Front Covers

Single Gang Application

EDS(C) and EFD(C) control stations
EFS(C) control stations
MC(C) control stations
FS(C) back box with cover assembly
FD(C) back box with cover assembly
EGF11 and EGF12 (Ground Fault)
N2S(C) Krydon: 2 device assembly
N2D(C) Krydon: 3 device assembly

Cat. #

NC CH1 QA
NC CH1 EFS QA
NC CH1 MC QA
NC CH1 FS QA
NC CH1 FD QA
NC CH1 EGF QA
NC CH1 N2S QA
NC CH1 N2D QA

Single Gang (Long) Application

EFD(C): 3 device control stations
N2S(C) Krydon: 3 device assembly
N2S(C) Krydon: 4 device assembly

Cat. #

NC CH1 3L QA
NC CH1 N2S 3L QA
NC CH1 N2S 4L QA

Double Gang Application

EDS(C) control stations
EDSCM32: 2 gang tandem
EDSCM 33: 3 gang tandem
FS(C) back box with cover assembly
FD(C) back box with cover assembly

Cat. #

NC CH2 QA
NC CH2L QA
NC CH3L QA
NC CH2 FS QA
NC CH2 FD QA

Custom covers can be supplied but must be accompanied by either a sample of the device to be covered or a copy of a drawing with all actual measurements of the device to be covered. Covers can also be color-coded. Consult factory.

Replacements for Pushbutton and Selector Switch Control Stations

4C

600 VAC Heavy Duty



CHS Controls AB
 Florettgatan 33
 SE-254 67 Helsingborg, Sweden
 Tel +46 42 38 61 00, Fax +46 42 38 61 29
 chs@chscontrols.se
 www.chscontrols.se

ED Series Pushbutton Contacts* Complete with Mounting Strap and Hardware



4C

Where Used	1 Circuit Universal	2 Circuits Universal	2 Circuits 1 Open - A 1 Closed - B	3 Circuits Universal
MC, EDS and EFS pushbutton stations and selector switches	ED11	ED12†	ED12†	
OAC pushbutton stations and selector switches	ED21	ED22†	ED22†	
EWC pushbutton stations		ED32†	ED32†	
EMP pushbutton stations	ED38	ED35		
EMP selector switches	ED38	ED35		
EFD factory sealed pushbutton stations and selector switches (M90)	ED11	ED12†	ED12†	
DSD962 pushbutton cover				ED13

Contact Ratings

Volts	Max. Current (Amperes)		Voltamperes		Continuous Current (Amperes)
	Make	Break	Make	Break	
600 VAC Heavy Duty (NEMA A600)					
120	60	6.0	7200	720	10
240	30	3.0	7200	720	10
480	15	1.5	7200	720	10
600	12	1.2	7200	720	10
Direct Current (NEMA P150)					
125	1.1	1.1	138	138	5

Contact Block Only (less strap)

Description	Cat. #
Contact Block	ESWP126

External Operating Buttons



Where Used	Colors Available	Cat. #
MC, EFS, and EFD – current design with nylon guards	Red, Green, Black	CF859 K1 ①
EMPS019, EMP019, EMPS029 and EMP029 – single operator FS, EFS, and EFD – previous design with aluminum guards	Red, Green, Black	CF705-K1 ①

- ① If desired, markings on indicating plates may be added to catalog number. Select from the list of standard markings below:
- | | | | |
|-----------|-------|-------|-----------|
| START | OFF | RESET | LIGHT ON |
| STOP | RUN | TRIP | HAND |
| ON | JOG | TEST | AUTOMATIC |
| EMERGENCY | OPEN | DOWN | RAISE |
| FORWARD | CLOSE | IN | LOWER |
| REVERSE | UP | OUT | |

* ESWP126 is the contact block without the mounting strap.
 † Two universal contact blocks, must be wired as two circuits, with one normally open and one normally closed.
 ‡ Use CF705-K1 for DEV11 and DEV12. To order DL legend plates see page 502 for markings.

Note: CF859-K1 and CF705-K1 come with 5 buttons.

**CHS Controls AB**

Florettgatan 33

SE-254 67 Helsingborg, Sweden

Tel +46 42 38 61 00, Fax +46 42 38 61 29

chs@chscontrols.se

www.chscontrols.se

Description	Page No.
Controls for Bulk Solids Handling	
AFA / AFAX Conveyor Alignment Switches	see page 573
AFU / AFUX Conveyor Control Safety Switches	see page 572
Custom Control Panels	
EJB Series	see pages 560–567
Ground Fault Control Stations	
EGF Series	see page 579
Grounding Indication / Control	
EGL Series	see page 571
Mine Signal Switches	
AFU Series	see page 574
Pendant Pushbutton Stations	
FLEXITITE™ Series	see pages 577–578
FLEXITITE™ D2X Series	see pages 575–576
Pushbuttons, Pilot Lights, and Selector Switches	
EMP Series	see page 568

	CHS Controls AB
	Florettgatan 33
	SE-254 67 Helsingborg, Sweden
	Tel +46 42 38 61 00, Fax +46 42 38 61 29
	chs@chscontrols.se
	www.chscontrols.se

5C EJB Custom-Built Control Panels

Globally Certified—Individually Customized

Cl. I, Div. 1 & 2, Groups B*, C, D UL and cUL approved
 Cl. I, Zones 1 & 2 Ex d IIB + H₂ T6
 Cl. II, Div. 1, Groups E, F, G Certified to ATEX Directive†
 Cl. II, Div. 2, Groups F, G NEMA 3, 7B*CD, 9EFG
 Cl. III IP66

The following pages will assist you in choosing the combination of features suited to your needs and requirements. The easy, five-step process will take you through the specification of cover openings, specifying devices, drilled and tapped conduit openings, device locations, and legend and nameplate selection.

After filling out your separate order form for each panel, fax it to your local Cooper Crouse-Hinds Distributor. Please consult the factory for alternatives not detailed in these pages, such as other conduit arrangements, terminal blocks, or circuit breaker operating handles.

Features:

- The foundation of the Custom-Built Control Panel is our tried and tested copper-free aluminum EJB enclosure. This corrosion resistant, heavy-duty enclosure features bolted construction, stainless steel hinges, and flexible tap-in mounting feet.

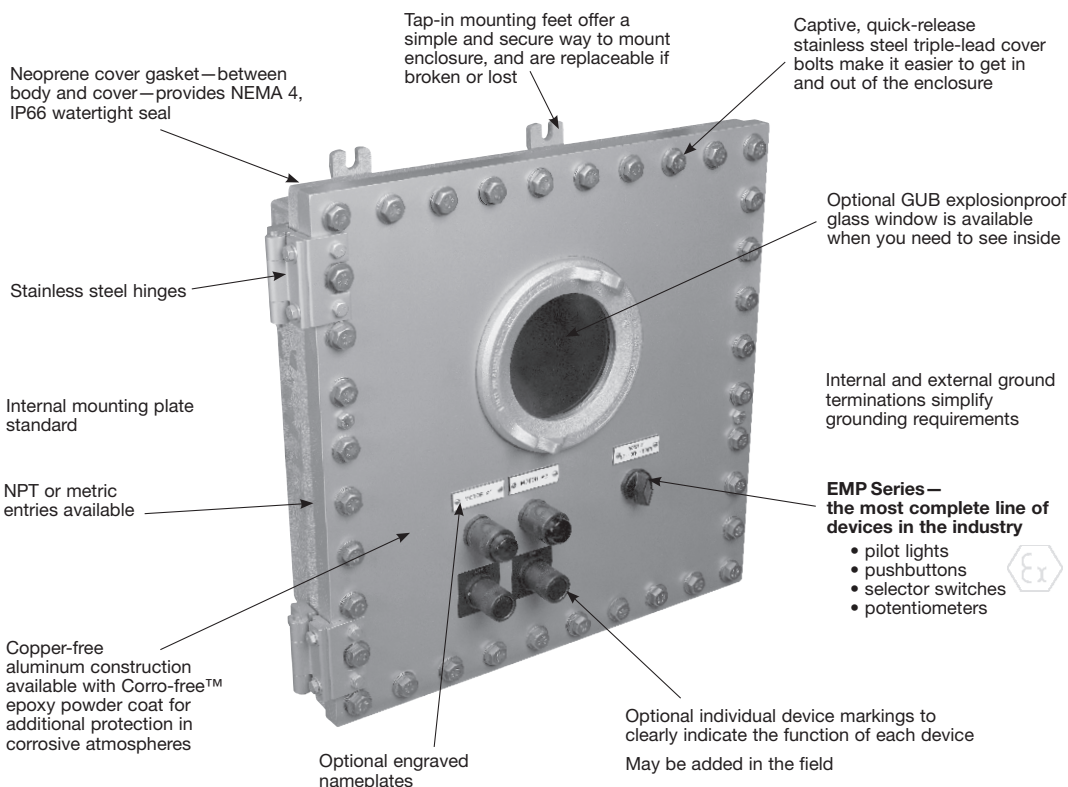





Certifications and Compliances:

EJB Custom Control Panels

- NEC/CEC:
 - Class I, Divisions 1 & 2, Groups B*, C and D
 - Class I, Zones 1 & 2
 - Class II, Division 1, Groups E, F and G
 - Class II, Division 2, Groups F and G
 - Class III
- NEMA: 3, 4, 7B*CD, 9EFG
- cUL to CSA Standard C22.2 No. 30—C22.2 No. 25 Cl. II (E, F, G)
- Ex d IIB + H₂ T6
- UL Standard 1203
- IP66
- Certified to the ATEX Directive when ordered with -ATEX suffix.
- Custom Control Panel is component certified only. For assembly certification, please consult factory.

*Groups C and D only when ordered with GUB window.
 † Certified to the ATEX Directive when ordered with ATEX suffix.

ATEX Certifications

- EJB Enclosure with Conduit Entries & Device Holes
 II 2 G Ex d IIB + H₂ Certificate #: ITS08ATEX15797U
- EMP Devices
 II 2 G Ex d IIB + H₂ Certificate #: ITS07ATEX15652U
- GUB0108 ATEX Window
 II 2 G Ex d IIB + H₂ Certificate #: ITS07ATEX15638U
- ECD Breather/Drain
 II 2 G Ex d IIB + H₂ Certificate #: ITS07ATEX15639U



CHS Controls AB
 Tel +46 42 38 61 00, Fax +46 42 38 61 29
 chs@chscontrols.se www.chscontrols.se

Globally Certified—Individually Customized

Ordering and receiving Cooper Crouse-Hinds EJB Custom-Built Control Panels is now easier and faster than ever. Follow the steps below, fill out a separate order form for each panel, and fax it to your local Cooper Crouse-Hinds Distributor. It's as simple as that!

Easy Five Step Ordering Process:

- 1 Specify cover openings and devices.
- 2 Specify conduit openings.
- 3 Determine device arrangement.
- 4 Specify device location.
- 5 Specify legend and nameplates.

Step 1

Specify the openings required for the cover of the enclosure.

Indicate in Section 1 of the order form the combination of devices, openings without devices, and windows required.

Total the number of device openings required based on the devices, openings and windows specified in Section 1.

Using Table 1, you can determine the smallest size enclosure required based upon the total number of devices/openings and the number of devices a window requires. (NOTE: The actual size of your custom panel enclosure may change based on the number and size of your entry requirements.)

TABLE 1

DEVICE AND WINDOW INFORMATION

Total # of Device Openings Available		Device Layout			EJB Enclosure Catalog Number
9	=	3	X	3	EJB100806
16	=	4	X	4	EJB121204
16	=	4	X	4	EJB121206
16	=	4	X	4	EJB121208
36	=	6	X	6	EJB161606
36	=	6	X	6	EJB161608
24	=	6	X	4	EJB181206
24	=	6	X	4	EJB181208
36	=	9	X	4	EJB241208
36	=	9	X	4	EJB241210
54	=	9	X	6	EJB241808
81	=	9	X	9	EJB242408
81	=	9	X	9	EJB242410
52	=	13	X	4	EJB361208
78	=	13	X	6	EJB361808
78	=	13	X	6	EJB261810
117	=	13	X	9	EJB362408

Requires same area as 12 devices.
May be installed in all boxes.

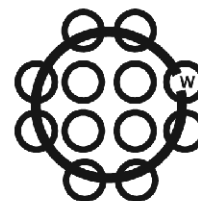

GUB0108—Symbol W
4-3/4" dia. viewing area

SIZE REQUIREMENTS

EJB Size	Max. No. Windows
121204 to 181208	1
241208 to 362408	2

CHS Controls AB

Florettgatan 33
SE-254 67 Helsingborg, Sweden
Tel +46 42 38 61 00, Fax +46 42 38 61 29
chs@chscontrols.se
www.chscontrols.se



Globally Certified—Individually Customized

Step 2

Specify the number, size and location of conduit openings required on the sides, top and bottom of the enclosure body using the information in Tables 2, 3, and 4.

Refer to Table 2 to determine if the enclosure selected in Step 1 will accommodate the required conduit openings.
From Table 3, determine the symbol(s) that correspond with the required conduit openings.

Place these symbols in the desired positions using the conduit arrangement diagrams in Table 4.

Any combination of the four arrangement diagrams may be used per side and all positions on a side with openings must have a symbol. The side number (1, 2, 3 or 4) must precede the conduit opening(s) symbols for the respective side. When a side of the enclosure does not require any conduit openings, the side number is omitted from the catalog number.

Enter the complete catalog number, including conduit opening designations, in Section 2 of the order form. Indicate on which side the hinges should be mounted. Check boxes in Section 2 for options desired.

Example:

In Step 1, customer selects an EJB161606 based on the number of devices/openings specified (See Section 1 of sample order form). The following conduit openings are required: (2) 1" on the left side of the top; no openings on the right side; (3) 2" on the bottom; and (2) 3/4" on the left side.

Table 2 indicates the maximum size allowed for three conduit openings in an EJB161606 is 2-1/2". Therefore, an EJB161606 would be suitable.

Table 3 indicates a 3/4" opening is symbol B, a 1" opening is symbol C, a 2" opening is symbol G and no opening is a 0.

Using the conduit arrangement diagrams in Table 4, place the symbols for the desired openings in the appropriate positions. Remember, any combination of the four arrangement diagrams may be used and all positions on a side with openings must have a symbol even if no opening is required in a particular position.

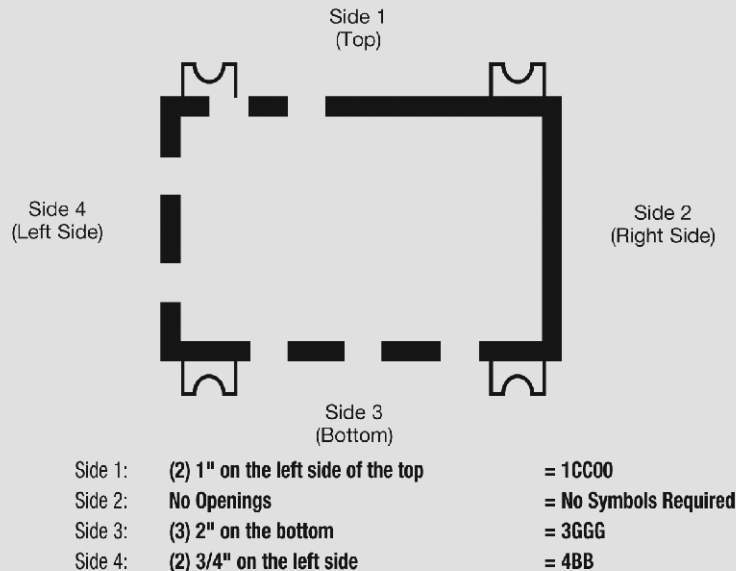

Complete catalog number is: **EJB161606- 1CC003GGG4BB**. Enter the completed catalog number, including conduit opening designations, in Section 2 of the order form. Indicate on which side the hinges should be mounted.



CHS Controls AB

Florettgatan 33
SE-254 67 Helsingborg, Sweden
Tel +46 42 38 61 00, Fax +46 42 38 61 29
chs@chscontrols.se
www.chscontrols.se

Globally Certified—Individually Customized

TABLE 2

CONDUIT ARRANGEMENTS

CAT #	Maximum Trade Size and Number of Openings								Spacing Dimensions						
	Top and Bottom (bb)				Sides (aa)				S	T	U	V	W	X	Y
	1	2	3	4	1	2	3	4							
Drilled and Tapped Openings															
EJB100806	3-1/2	3	1-1/2	1-1/4	3-1/2	2-1/2	1-1/4	3/4	3-3/4	2-5/16	1-15/16	2-3/4	2-1/2	2-1/2	1-3/4
EJB121204	1-1/2	1-1/2	1-1/2	1-1/4	1-1/2	1-1/2	1-1/2	1-1/4	3	2-1/4	2-1/4	3-5/8	3-5/8	3-1/16	3-1/16
EJB121206	3-1/2	3-1/2	1-1/2	1-1/4	3-1/2	3-1/2	1-1/2	1-1/4	3-3/4	3	3	3-5/8	3-5/8	3-1/16	3-1/16
EJB121208	5	3-1/2	1-1/2	1-1/4	5	3-1/2	1-1/2	1-1/4	4-3/4	3	3	3-5/8	3-5/8	3-1/16	3-1/16
EJB161606	3-1/2	3-1/2	2-1/2	2	3-1/2	3-1/2	2-1/2	2	3-3/4	3	3	4-5/8	4-5/8	4-3/16	4-3/16
EJB161608	5	5	3	2	5	5	3	2	4-3/4	3-1/4	3-1/4	6	4-5/8	4-3/16	4-3/16
EJB181206	3-1/2	3-1/2	3-1/2	2-1/2	3-1/2	3-1/2	1-1/2	1-1/4	3-3/4	3	3	6	3-5/8	4-5/8	3-1/16
EJB181208	5	5	3-1/2	2-1/2	5	3-1/2	1-1/2	1-1/4	4-3/16	4-3/16	3	6	3-5/8	4-5/8	3-1/16
EJB241208	5	5	5	3-1/2	5	3-1/2	1-1/2	1-1/4	5-1/8	4-3/16	3	8-7/16	3-5/8	6	3-1/16
EJB241210	6	6	5	3-1/2	6	3-1/2	1-1/2	1-1/4	6-1/8	4-3/4	3	8-7/16	3-5/8	6	3-1/16
EJB241808	5	5	5	3-1/2	5	5	3-1/2	2-1/2	5-1/4	4-3/16	4-3/16	8-7/16	6	6	4-5/8
EJB241810	6	6	5	3-1/2	6	6	3-1/2	2-1/2	6-1/4	4-3/4	4-3/4	8-7/16	6	6	4-5/8
EJB242408	5	5	5	3-1/2	5	5	5	3-1/2	5-3/8	4-3/16	4-3/16	8-7/16	8-7/16	6	6
EJB242410	6	6	5	3-1/2	6	6	5	3-1/2	6-3/8	4-3/4	4-3/4	8-7/16	8-7/16	6	6
EJB361208	5	5	5	5	5	3-1/2	1-1/2	1-1/4	4-3/4	4-7/16	3	8-7/16	3-5/8	8-7/16	3-1/16
EJB361808	5	5	5	5	5	5	3-1/2	2-1/2	5-1/2	4-7/16	4-7/16	8-7/16	6	8-7/16	4-5/8
EJB361810	6	6	5	5	6	6	3-1/2	2-1/2	6-1/2	4-3/4	4-3/4	8-7/16	6	8-7/16	4-5/8
EJB362408	5	5	5	5	5	5	5	3-1/2	6	4-3/16	4-3/16	8-7/16	8-7/16	8-7/16	6

TABLE 3

SYMBOLS FOR OPENINGS

NPT Conduit Size	Drilled & Tapped Hole Symbol	Metric Openings	Drilled & Tapped Hole Symbol
1/2	A	M16	AM
3/4	B	M20	BM
1	C	M25	CM
1-1/4	E	M32	EM
1-1/2	F	M40	FM
2	G	M50	GM
2-1/2	H	M63	HM
3	J		
3-1/2	K		
4	L		
5	M		
6	N		

TABLE 4

CONDUIT ARRANGEMENT DIAGRAMS

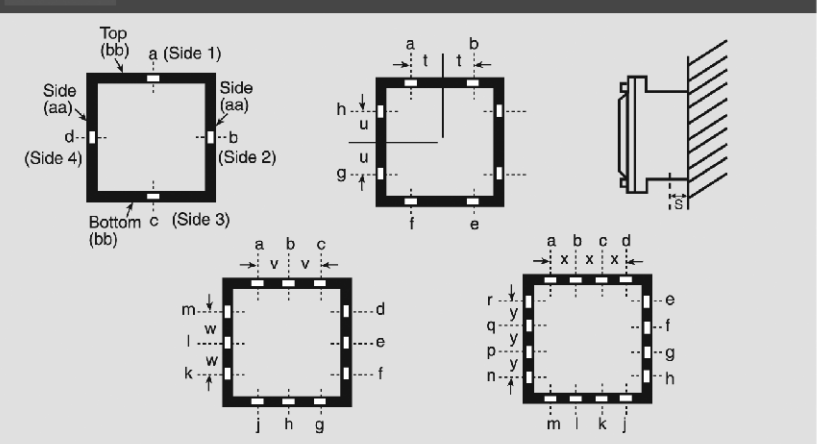

Step 3

Based upon the EJB selected, use Section 3 of the order form and outline the maximum number of columns and rows available (from Table 1) beginning in the upper left corner. Fill in the length of each side in the space provided.

Note that the left side will be hinged unless otherwise specified in Section 2. In our example, an EJB161606 was selected and according to Table 1, a total of 36 device spaces are available (6 columns and 6 rows). See sample order form.

Step 4

Place the appropriate letter symbol from Section 1 of the order form in the position you desire the devices or openings to be located. If a window is required, outline the position and number of spaces the window will occupy and place the symbol of the window (w) in the center.

Note that 2 windows per enclosure can be used. If more windows are required contact factory. (See appropriate window information in the sample order form)

CHS Controls AB
 Florettgatan 33
 SE-254 67 Helsingborg, Sweden
 Tel +46 42 38 61 00, Fax +46 42 38 61 29
 chs@chscontrols.se
 www.chscontrols.se

Globally Certified—Individually Customized

Step 5

Indicate the desired device marking (DSL legend plate) or engraved plate for each device or window in Section 4 of the order form.

Engraved plates will be located above the device or window and are white letters on a black background. If an engraved plate is desired, fill in desired wording on engraved plate (up to 2 lines) on Section 4 of order form. If a device marking is required on EMP device, insert the DSL catalog number from those listed below (Table 5) on Section 4 of order form under column labeled "Device Marking." Be sure to specify the row and column location of the EMP device being marked. See sample order form.

That's it. *It's that simple.* Now fax the order form to your local Cooper Crouse-Hinds Distributor.

TABLE 5

LEGEND PLATE SELECTOR CHART

Use the charts below to select the appropriate legend plate(s) for your application. Markings shown in bold print are etched; all others are stamped.

Single Function Legend Plates		Double Function Legend Plates		Triple Function Legend Plates									
Marking	Cat #.	Marking	Cat #.	Marking	Cat #.								
Automatic	DSL16	Blank with 2 fields	DSL03	Auto-Off-Hand	DSL49								
Blank	DSL01	For-Rev	DSL30	Blank with 3 fields	DSL04								
Blank with single field	DSL02	Hand-Auto	DSL29	Fast-Off-Slow	DSL41								
Close	DSL21	In-Out	DSL35	For-Off-Rev	DSL40								
Down	DSL23	Off-On	DSL48	Hand-Off-Auto	DSL39								
Emerg. Stop	DSL17	Open-Close	DSL32	Run-Off-Jog	DSL38								
Fast	DSL46	Raise-Lower	DSL36	Open-Off-Close	DSL43								
Forward	DSL18	Run-Jog	DSL28	Raise-Off-Lower	DSL87								
Hand	DSL15	Safe-Run	DSL86	Slow-Off-Fast	DSL88								
In	DSL24	Start-Stop	DSL37	Up-Off-Down	DSL44								
Jog	DSL10	Slow-Fast	DSL65	1-Off-2	DSL42								
Lower	DSL27	Up-Down	DSL33	Note: Background color for all legend plates is black with the following exceptions: <table border="1"> <thead> <tr> <th>Marking</th> <th>Plate Color</th> </tr> </thead> <tbody> <tr> <td>Start</td> <td>Green</td> </tr> <tr> <td>Stop</td> <td>Red</td> </tr> <tr> <td>Emerg. Stop</td> <td>Red</td> </tr> </tbody> </table>		Marking	Plate Color	Start	Green	Stop	Red	Emerg. Stop	Red
Marking	Plate Color												
Start	Green												
Stop	Red												
Emerg. Stop	Red												
On	DSL07												
Off	DSL08												
Open	DSL20												
Out	DSL25												
Power On	DSL14												
Raise	DSL26												
Reset	DSL12												
Reverse	DSL19												
Run	DSL09												
Safe	DSL85												
Slow	DSL47												
Start	DSL05												
Stop	DSL06												
Test	DSL13												
Trip	DSL11												
Up	DSL22												

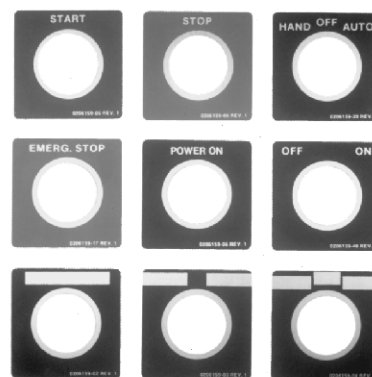



CHS Controls AB
 Florettgatan 33
 SE-254 67 Helsingborg, Sweden
 Tel +46 42 38 61 00, Fax +46 42 38 61 29
 chs@chscontrols.se
 www.chscontrols.se

Globally Certified—Individually Customized



CHS Controls AB
 Florettgatan 33
 SE-254 67 Helsingborg, Sweden
 Tel +46 42 38 61 00, Fax +46 42 38 61 29
 chs@chscontrols.se
 www.chscontrols.se

Please photocopy and fax all pages of order form (Sections 1-4) to your local Cooper Crouse-Hinds Distributor.

Section 1: EMP Style Operators—UL, cULus and ATEX

Number of Devices: Indicate the Number of Devices, Openings Without Devices and Window(s) Required.

Pilot Lights			
	Diagram	Symbol	Quantity
EMP009-J1 (Red)		A	_____
EMP009-J1-LED		A1	_____
EMP0090-J1		A2	_____
EMP0098-J1		A4	_____
EMP009-J3 (Green)		B	_____
EMP009-J3-LED		B1	_____
EMP0090-J3		B2	_____
EMP0098-J3		B4	_____
EMP009-J6 (Amber)		C	_____
EMP009-J6-LED		C1	_____
EMP0090-J6		C2	_____
EMP0098-J6		C4	_____
EMP009-J10 (Clear)		E	_____
EMP0090-J10		E2	_____
EMP0098-J10		E4	_____
EMP009-J11 (Blue)		F	_____
EMP0090-J11	F2	_____	
EMP0098-J11	F4	_____	

Selector Switches – Two position			
	Diagram	Symbol	Quantity
EMP049		Q	_____
EMP059		R	_____

Selector Switches – Three position			
	Diagram	Symbol	Quantity
EMP069		S	_____
EMP069-S634		S4	_____
EMP069-S635		S5	_____
EMP079		T	_____
EMP079-S634		T4	_____
EMP079-S635		T5	_____
EMP089		U	_____
EMP089-S634		U4	_____
EMP089-S635		U5	_____

Pushbuttons—Single Pushbutton			
	Diagram	Symbol	Quantity
EMP019 (Black)		G	_____
EMP019 (Red)		H	_____
EMP019 (Green)		J	_____
EMP098 (Red)		K	_____

Selector Switches – Keyed Selector Switches			
	Diagram	Symbol	Qty
EMP0491		Q6	_____
EMP0492		Q7	_____
EMP0493		Q8	_____
EMP0591		R6	_____
EMP0592		R7	_____
EMP0593		R8	_____
EMP0691		S6	_____
EMP0692		S7	_____
EMP0693		S8	_____
EMP0694	S9	_____	
EMP0791		T6	_____
EMP0792		T7	_____
EMP0793		T8	_____
EMP0794		T9	_____
EMP0891		U6	_____
EMP0892		U7	_____
EMP0893		U8	_____
EMP0894		U9	_____

Pushbuttons—Double Pushbutton, Single Operator			
	Diagram	Symbol	Quantity
EMP029 (Black)		L	_____
EMP029 (Red)		M	_____
EMP029 (Green)		N	_____

Pushbuttons—Double Pushbutton, Double Operator			
	Diagram	Symbol	Quantity
EMP039		P	_____

Total Number of all Devices on this page _____

Globally Certified—Individually Customized

Section 1: EMP Style Operators Continued

Number of Devices: Indicate the Number of Devices, Openings Without Devices and Window(s) Required.

Openings Without Devices (For Future Expansion)	
	Symbol Quantity
3/4" - 14 NPSM Opening (plugged)	V _____

Windows			
	Symbol	Quantity	# of Openings
GUB0108	W	_____	_____

Total Number of all Device
Openings from previous page _____

Total Number of all Devices /
Openings from Section 1 _____

5C



CHS Controls AB
 Florettgatan 33
 SE-254 67 Helsingborg, Sweden
 Tel +46 42 38 61 00, Fax +46 42 38 61 29
 chs@chscontrols.se
 www.chscontrols.se

Cl. I, Div. 1 & 2, Groups B, C, D Explosionproof
 Cl. II, Div. 1, Groups E, F, G Dust-Ignitionproof
 Cl. II, Div. 2, Groups F, G Raintight
 Cl. III Wet Locations
 II 2 G Ex d IIB + H₂, T5 NEMA 3, 7BCD, 9EFG

As indicated in the listings, certain barrel assemblies are the same as those used in complete EMP units and may be utilized as replacements.

The remainder are primarily for use with hazardous area boxes to assemble special control stations. For additional information, see page 560 describing custom-built control panels.

Certifications and Compliances:

- Class I, Division 1 & 2, Groups B, C, D
- Class II, Division 2, Groups E, F, G
- Class III
- NEMA/EEMAC: 3, 7BCD, 9EFG
- UL Standard 1203
- CSA Standard C22.2 No 30
- CENELEC
- ATEX Certificate ITS07 ATEX 15652U

Ordering Information:

Select the Cat. No. from the listings. For pilot lights and illuminated pushbuttons, specify color of jewel using symbols from the table below. For pushbuttons and selector switches, optional markings may be specified in the tables below.

Group 1:

Standard assemblies are for replacement in complete EMP units or for custom-built control panels. Short assemblies are for custom-built control panels only. Both assemblies may be used with System 4 Control Stations.

Pilot light‡



Diagram	Standard Assembly Cat. #
(120V)*	EMP009 ①

Single pushbutton Double pushbutton, single operator

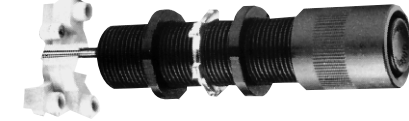

Diagram	Short Cat. #	Standard Cat. #
	EMPS019 ②	EMP019 ②
	EMPS029 ②	EMP029 ②

Double pushbutton, double operator

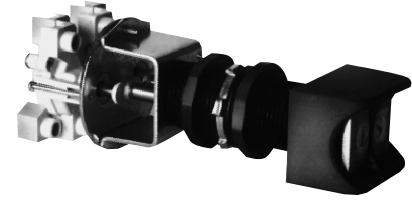

Diagram	Short Assembly Cat. #	Standard Assembly Cat. #
	EMPS039 ②	EMP039 ②

Two-position selector switch



Diagram Position 1	Position 2	Short Assembly Cat. #	Standard Assembly Cat. #
A1 A2	A1 A2	EMPS049 ②	EMP049 ②
A1 B1 A2 B2	A1 B1 A2 B2	EMPS059 ②	EMP059 ②

Three-position selector switch

Diagram Position 1	Position 2	Position 3	Short Assembly Cat. #	Standard Assembly Cat. #
A1 A2	A1 A2	A1 A2	EMPS069 ②	EMP069 ②
A1 B1 A2 B2	A1 B1 A2 B2	A1 B1 A2 B2	EMPS079 ②	EMP079 ②
A1 B1 A2 B2	A1 B1 A2 B2	A1 B1 A2 B2	EMPS089 ②	EMP089 ②

①Add color symbol for each pilot light from table below.

Color	Symbol	Color	Symbol
Red	J1	Clear	J10
Green	J3	Blue	J11
Amber	J6		

②If desired, markings on indicating plates may be added to catalog number. Select from the list of standard markings below:

Push Button Station Marking

START	OFF	RESET	LIGHT ON	EMERGENCY	OPEN	DOWN	RAISE
STOP	RUN	TRIP	HAND	FORWARD	CLOSE	IN	LOWER
ON	JOG	TEST	AUTOMATIC	REVERSE	UP	OUT	

‡ LED pilot lights can be furnished in place of standard incandescent pilot lamps. Add suffix LED to end of catalog number after last color symbol.

* Other voltages available. Consult factory. For 24 VDC operation, add suffix S300.

⌘ The following suffixes may be used with these catalog numbers: S634 - Momentary contact clockwise, spring return to center; S635 - Momentary contact counter-clockwise, spring return to center.

CHS Controls AB
 Tel +46 42 38 61 00, Fax +46 42 38 61 29
 chs@chscontrols.se www.chscontrols.se

EMP and EMPS Barrel Assemblies

Cl. I, Div. 1 & 2, Groups B, C, D
 Cl. II, Div. 1, Groups E, F, G
 Cl. II, Div. 2, Groups F, G
 Cl. III
 II 2 G Ex d IIB + H₂, T5

Explosionproof
 Dust-Ignitionproof
 Raintight
 Wet Locations
 NEMA 3, 7BCD, 9EFG

5C

Group 2: For custom-built control panels.

Illuminated pushbutton†

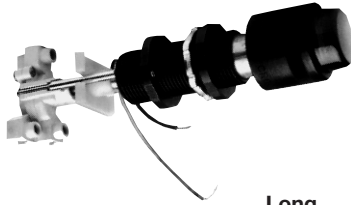

Diagram		Long Assembly Cat. #
	120V pilot light	EMP0090 ①
	120V pilot light	EMP0098 ①

Maintained Contact Pushbutton



Diagram		Long Assembly Cat. #
Up	Down	
A1 A2	A1 A2	EMP098 ②

①Add color symbol for each pilot light from table below.

Color	Symbol	Color	Symbol
Red	J1	Clear	J10
Green	J3	Blue	J11
Amber	J6		

Two-position selector switch, key operated



②If desired, markings on indicating plates may be added to catalog number. Select from the list of standard markings below:

Push Button Station Marking

START	OFF	RESET	LIGHT ON	EMERGENCY	OPEN	DOWN	RAISE
STOP	RUN	TRIP	HAND	FORWARD	CLOSE	IN	LOWER
ON	JOG	TEST	AUTOMATIC	REVERSE	UP	OUT	

Diagram		Key Removal	Short Assembly Cat. #	Standard Assembly Cat. #
Position 1	Position 2			
A1 A2	A1 A2	Both positions Left only Right only	EMPS0491 ② EMPS0492 ② EMPS0493 ②	EMP0491 ② EMP0492 ② EMP0493 ②
A1 A2	A1 A2	Both positions Left only Right only	EMPS0591 ② EMPS0592 ② EMPS0593 ②	EMP0591 ② EMP0592 ② EMP0593 ②

Three-position selector switch, key operated

Diagram			Key Removal	Short Assembly Cat. #	Standard Assembly Cat. # ✱
Position 1	Position 2	Position 3			
A1 A2	A1 A2	A1 A2	All Center only Left only Right only	EMPS0691 ② EMPS0692 ② EMPS0693 ② EMPS0694 ②	EMP0691 ② EMP0692 ② EMP0693 ② EMP0694 ②
A1 A2	A1 A2	A1 A2	All Center only Left only Right only	EMPS0791 ② EMPS0792 ② EMPS0793 ② EMPS0794 ②	EMP0791 ② EMP0792 ② EMP0793 ② EMP0794 ②
A1 A2	A1 A2	A1 A2	All Center only Left only Right only	EMPS0891 ② EMPS0892 ② EMPS0893 ② EMPS0894 ②	EMP0891 ② EMP0892 ② EMP0893 ② EMP0894 ②

† LED pilot lights can be furnished in place of standard incandescent pilot lamps.
 Add suffix LED to end of catalog number after last color symbol.
 ✱ The following suffixes may be used with these catalog numbers: S634 - Momentary contact clockwise, spring return to center; S635 - Momentary contact counter-clockwise, spring return to center.

CHS Controls AB
 Florettgatan 33
 SE-254 67 Helsingborg, Sweden
 Tel +46 42 38 61 00, Fax +46 42 38 61 29
 chs@chscontrols.se
 www.chscontrols.se



EMP and EMPS Barrel Assemblies



CHS Controls AB
 Tel +46 42 38 61 00, Fax +46 42 38 61 29
 chs@chscontrols.se www.chscontrols.se

Cl. I, Div. 1 & 2, Groups B, C, D Explosionproof
 Cl. II, Div. 1, Groups E, F, G Dust-Ignitionproof
 Cl. II, Div. 2, Groups F, G Raintight
 Cl. III Wet Locations
 II 2 G Ex d IIB + H₂, T5 NEMA 3, 7BCD, 9EFG

Dimensions* In Inches:

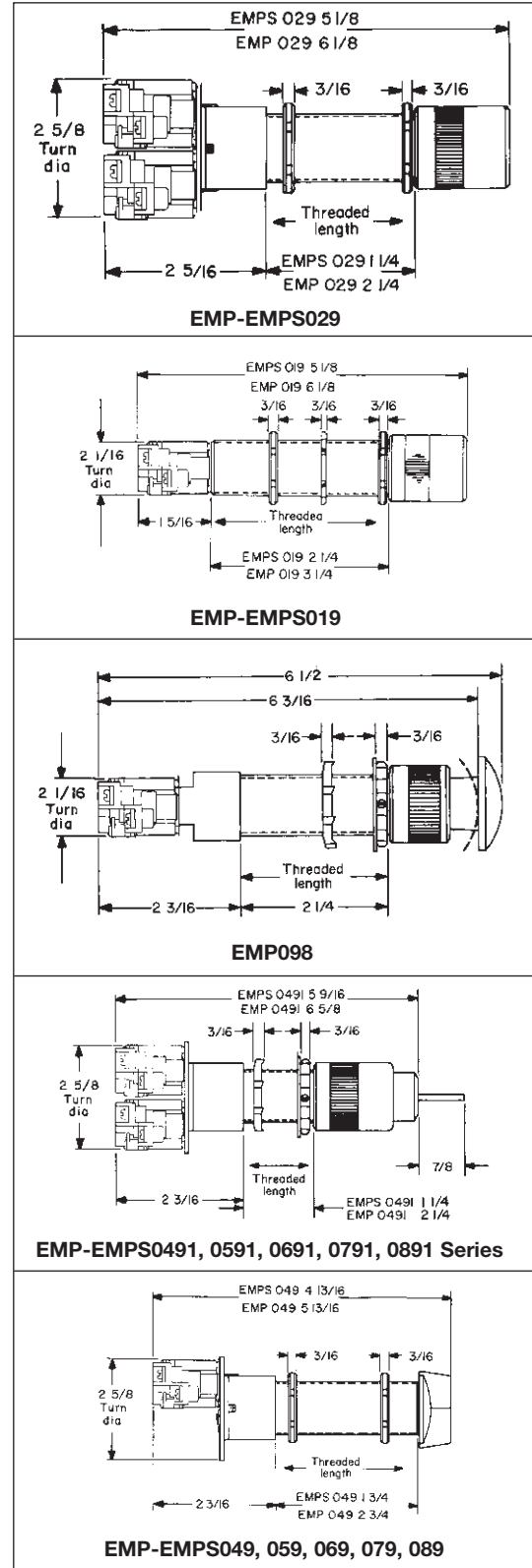
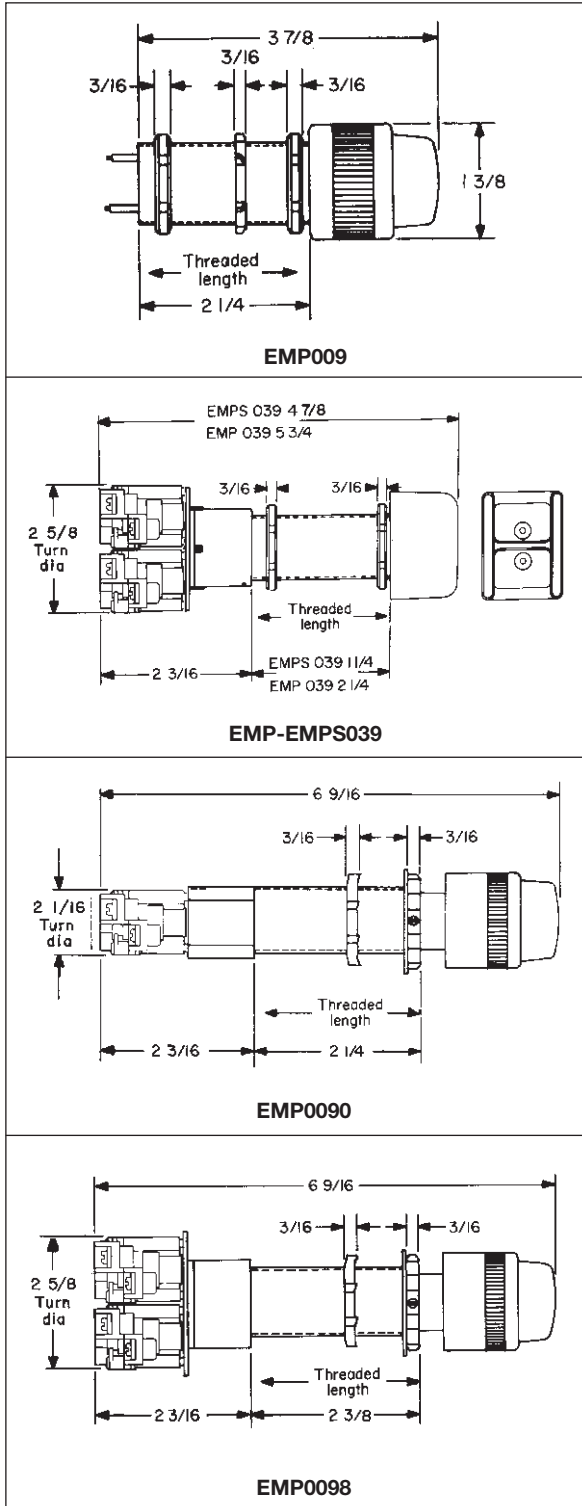

*Dimensions are approximate, not for construction purposes.

All barrel assemblies are 3/8"-14 NPSM thread size.

EGL Static Grounding Indicator

With Automated Pump Control and Static Ground Verification System

Cl. I, Div. 1 & 2, Groups B, C, D
Cl. I, Zone 1 & 2 IIB + H₂
Cl. II, Div. 1, Groups E, F, G
Cl. II, Div. 2, Groups F, G
Cl. III

UL/cUL Listed
NEMA 3, 4X, 7BCD, 9FG, 12
Explosionproof
Dust-Ignitionproof
Raintight / Wet Locations

5C

Applications:

EGL Static Grounding Indicator is the ideal product for safe loading/unloading of ethanol, biofuel, petroleum, chemicals, plastics and other combustible materials. The EGL is mounted adjacent to loading/unloading areas and connected to transportation tank vehicles, railcars, drums or other portable containers to prevent explosions due to static discharge during product transfer by providing:

- A ground path for static build-up
- Automatic pump shutdown when static grounding circuit is broken
- Visual indication of safe, static grounding before, during and after loading and unloading operations

Features and Benefits:

- Static ground verification system provides ground path for static build-up to ensure safe product transfer
- Integrated control relay allows for safe control of electrically operated pumps or valves, and for energizing remote indicators
- Stainless steel clamp for grounding connection provides industrial durability, corrosion resistance, and increased product lifetime
- Interior and exterior epoxy powdered paint finish provides superior corrosion resistance inside and out
- LED pilot lights provide long-lasting visual identification of status of ground connection
- ECD Type 4X drain protects interior equipment from environmental moisture and condensation, rain water, and hose-down applications
- NEMA 4X compact, hose-tight, and corrosion-resistant enclosure offers years of service in harsh industrial environments
- 25 ft. safety fluorescent yellow cord is easily identifiable to ensure safety and reduce tripping hazard
- Neoprene cover gasket provides a watertight seal to meet UL Type 4 (NEMA 4) requirements
- Stainless steel hinges are corrosion resistant while providing safe and easy access to interior of enclosure
- Waterguard™ desiccant packet absorbs and removes water/moisture and protects the enclosed equipment when not energized
- Adjustable mounting feet provide ease of mounting during installation

Certifications & Compliances:

- Class I, Divisions 1 & 2, Groups B, C, D
- Class I, Zone 1&2 IIB + H₂
- Class II, Division 1, Groups E, F, G
- Class II, Division 2, Groups F, G
- Class III
- UL/cUL Listed
- IP 65
- NEMA 3, 4X, 7BCD, 9FG, 12

Standard Materials:

- Enclosure: Copper-free aluminum with interior and exterior epoxy powder coat
- Clamp: Stainless steel
- Clamp Grips: Polyvinylchloride dipped
- Gasket: Neoprene

Electrical Rating Ranges:

- 120-volt AC supply
- Control relay interlocking contact: 15A at 277VAC; 10A at 600VAC
- Dual-tapped 240 and 480 VAC Step Down Transformer available
- Provides 4k ohms or less switching impedance



Ordering Information

Description
Indicator with two pilot lights*

* Includes one red and one green pilot light

Catalog Number
EGL210-J1-J3

Options:

Description	Suffix
Internal space heaters to limit condensation build-up	R11
Transformer suitable for both 220/240VAC or 440/480VAC applications	S883
50 foot cord	50FC

Options:

Replacement Parts:

Ground clamp	EGL-K1
Ground clamp assembly (includes 25 ft. cord, connector and clamp)	EGL:20109-B
EGL210 universal interior replacement kit	EGL210-R1
Pilot lights (Red)	EMP009-J1-LED
Pilot lights (Green)	EMP009-J3-LED
Mounting feet	EJB-KIT5
Transformer (220/240VAC; 440/480VAC)	EGL S883 KIT
Space heater	EGL R11 KIT
Pilot light plug kit	EGL PLUG KIT

Weight & Dimensions:

EGL Assembly:

Weight = 32 lbs (14.5 kg)

Dimensions = inches (centimeters)

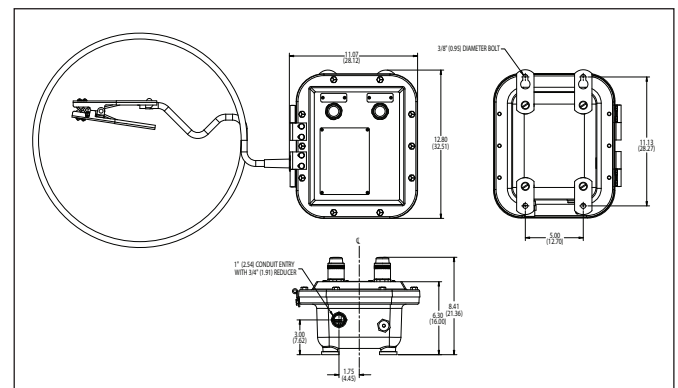



CHS Controls AB
 Tel +46 42 38 61 00, Fax +46 42 38 61 29
 chs@chscontrols.se www.chscontrols.se

Applications:

AFU and AFUX conveyor control switches are used:

- As emergency or normal "STOP" switch for conveyor lines, cranes, unloaders, bulk handling systems and similar equipment
- In steel mills, mining and ore and coal handling operations, automotive and other assembly lines, warehouses, loading docks and various process industry facilities
- In the control circuit of magnetic motor starters to shut down motor-driven conveyors or other machinery when switch is actuated

AFU series complies with requirements for use in Class II areas having combustible dusts that may or may not be electrically conductive.

AFU series are also gasketed for use in hosedown areas even when combustible dusts are present.

AFUX series complies with requirements for use in NEC Class I areas which are hazardous due to the presence of flammable vapors or gases. AFUX series also complies with requirements for use in NEC Class I areas which are hazardous due to the presence of flammable vapors or gases. AFUX series also complies with NEC requirements for use in Class II hazardous areas, or for use in NEC hazardous areas classified simultaneously as Class I and Class II.

Features:

- Furnished with one or two end units, each containing 2-NO and 2-NC contact arrangements.
- Precision switches provide maintained contact (switches have a snap action mechanism).
- Enclosure has three 1" conduit hubs – two for horizontal through feed and one at the bottom. Cast mounting lugs on 1½" centers permit attachment to the web of a standard 3" angle iron.
- In installation, the actuating line or cable is connected from a fixed point to the loop on the end unit. A pull on the line of the required operating force and with a total movement of ½" actuates the plunger, opens the switch and trips the red painted indicating arm forward, which locks the plunger in the actuated (switch open) position. Returning the indicating arm to its normal position resets the mechanism. A typical installation would include single end switch units at each end of the conveyor with double end switch units between.
- Depending on the size and length of line, supports at properly spaced intervals may be necessary to ensure that the line or cable weight alone will not actuate switch.

Certifications and Compliances:

AFU Series

- NEC/CEC:
 - Class II, Division 1, Groups E, F, G
 - Class II, Division 2, Groups F, G
 - Class III
- Encl. 3, 5
- NEMA: 3, 4, 9EFG
- IP66
- UL Standard: 698
- CSA Standard: 22.2 No. 30

AFUX Series

- NEC:
 - Class I, Division 1 & 2, Groups C, D
 - Class II, Division 1, Groups E, F, G
 - Class II, Division 2, Groups F, G
 - Class III
- NEMA: 3, 7CD, 9EFG
- IP65
- UL Standard: 698
- cUL

Standard Materials:

- Enclosure – *Feraloy*® iron alloy
- Plunger – stainless steel
- Loop – bronze
- Indicating arm – steel

Standard Finishes:

- *Feraloy* iron alloy – electrogalvanized and aluminum acrylic paint
- Steel – electrogalvanized with chromate finish (red acrylic paint on indicating arm)
- Bronze – natural

Options:

Description **Suffix**
 Finish: *Corro-free*™ epoxy powder coat – for coating outside only. **S752**

Electrical Rating:

- Control circuit switch – 15 AMP, 600 VAC max.

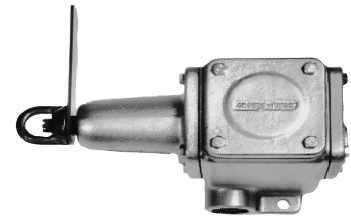

AFU0333-50 Single end left

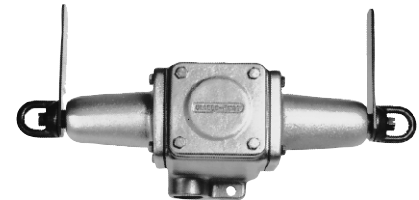

AFU0333-66 Double end

Ordering Information

Description	Maximum Weight of Unsupported Line or Cable Without Actuating Switch† (lbs.)	Total Operating Force Required (lbs.)	Contact Arrangements With 2-NO, 2-NC in Each End Unit	
			Cat. #	Cat. #
Single end left	15	25	AFU0333 50	AFUX0333 50
Single end left	25	50	AFU0333 60	AFUX0333 60
Single end right	15	25	AFU0333 05	AFUX0333 05
Single end right	25	50	AFU0333 06	AFUX0333 06
Double end	15	25	AFU0333 55	AFUX0333 55
Double end	25	50	AFU0333 66	AFUX0333 66

†A galvanized steel aircraft cable, supported every 10' is recommended.

Dimensions In Inches*:

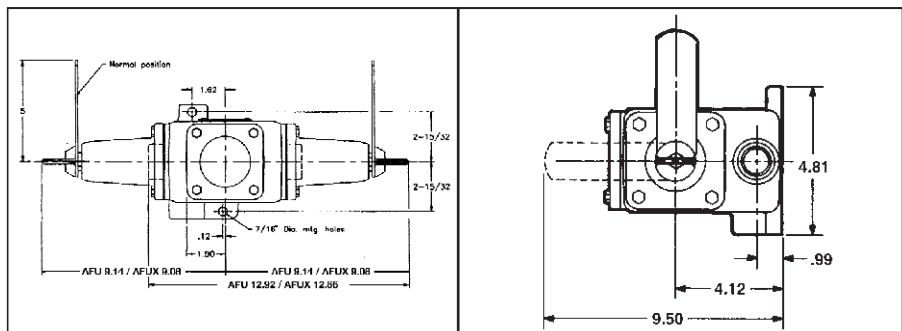

AFA and AFAX Conveyor Belt Alignment Switch



CHS Controls AB

Tel +46 42 38 61 00, Fax +46 42 38 61 29
chs@chscontrols.se www.chscontrols.se

Cl. I, Div. 1 & 2, Groups C, D
Cl. II, Div. 1, Groups E, F, G
Cl. II, Div. 2, Groups F, G
Cl. III
NEMA 3, 4, 7CD, 9EFG

Explosionproof
Dust-Ignitionproof
Raintight
Wet Locations

5C

Applications:

AFA, AFAX conveyor belt alignment switches are used:

- As emergency or normal "STOP" switch for conveyor belts whenever they become misaligned or run off their tracks due to excessive speed, uneven load, leveling, breakage and/or other problems.
- In steel mills, mining and ore and coal handling operations, automotive and other assembly lines, warehouses, loading docks, grain loading and handling facilities, and various other bulk handling operations.
- In the control circuit of magnetic motor starters to shut down motor-driven conveyors in case of abnormal belt misalignment or run-off.

AFA series complies with requirements for use in Class II areas having combustible dusts that may or may not be electrically conductive.

AFA series are also gasketed for use in hosedown areas even when combustible dusts are present.

AFAX series complies with requirements for use in NEC Class I areas which are hazardous due to the presence of flammable vapors or gases. AFAX series also complies with NEC requirements for use in Class II hazardous areas, or for use in NEC hazardous areas classified simultaneously as Class I and Class II.

Features:

- Furnished with precision switches that provide normally open and normally closed contacts (switches have a snap action mechanism).
- Housing consists of a center section which can be mounted either vertically or horizontally, and a switch housing with an attached switch operating arm.
- Enclosure has three 1" conduit hubs. Cast mounting lugs on 1 1/2" center permit attachment to the web of a standard 3" angle iron.
- Operating arm has 3/2" long stainless steel protective roller. Approximately 3/4" lateral movement of operating arm actuates switch.
- Spring loaded operating arm will automatically return switch to normal position when belt interference is removed.
- A severe conveyor belt run-off can rotate the operating arm counter-clockwise up to 85 degrees without damage to the switch mechanism.
- Installation of AFA or AFAX unit on either side of a conveyor belt allows approximately 1" or a predetermined allowable belt misalignment before switch is actuated. A typical installation would include a pair of AFA or AFAX units at each end of the conveyor belt where belt returns.

Certifications and Compliances:

AFA SERIES

- NEC/CEC:
 - Class II, Division 1, Groups E, F, G
 - Class II, Division 2, Groups F, G
 - Class III
- NEMA: 3, 4, 9EFG
- IP66
- UL Standard: 698
- CSA C22.2 No. 25

AFAX SERIES

- NEC:
 - Class I, Division 1 & 2, Groups C, D
 - Class II, Division 1, Groups E, F, G
 - Class II, Division 2, Groups F, G
 - Class III
- NEMA: 3, 7CD, 9EFG
- IP65
- UL Standard: 1203

Standard Materials:

- Enclosure – *Feraloy*® iron alloy
- Bearing and operating arm – stainless steel with plastic end caps

Standard Finishes:

- *Feraloy* – electrogalvanized and aluminum acrylic paint
- Stainless steel – natural

Typical AFA Switch Application

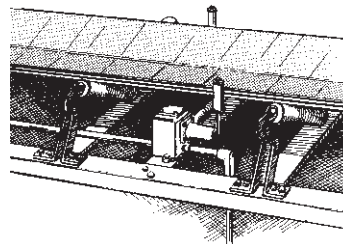

Dimensions In Inches*:

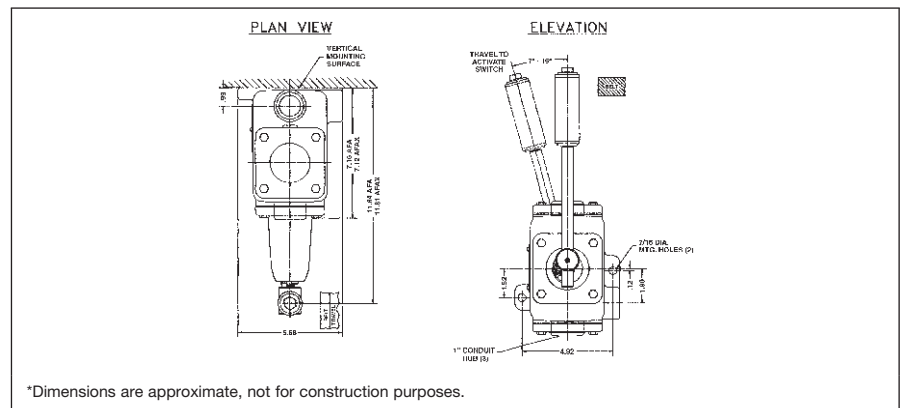

Electrical Rating:

- Control circuit switches – 15 AMP, 600 VAC max.

Ordering Information

Contact Arrangement	Diagram	Cat. #
2 normally open		AFA20
2 normally closed		AFAX20

Options:

Description	Suffix
Finish: <i>Corro-free</i> ™ epoxy powder coat – for coating outside only.	S752

600 VAC

Applications:

AFU mine signal switches are used:

- For signalling circuits or remote control of magnetic motor starters
- In non-hazardous areas of mines or process industry facilities where a rugged enclosure is needed for protection from falling ore and other material or dripping water
- Mounted on walls or in shaft ways and actuated by pulling line or cable attached to the loop at the bottom

Features:

- Sturdy raintight enclosure with heavy mounting lugs
- Wires enter enclosure through clearance holes in the underside
- Switches are actuated by a spring-loaded plunger which returns to the normal position when the operating force is removed
- Units are furnished with heavy duty motor control push buttons. Several of these may be interconnected electrically for remote control of a magnetic motor starter from more than one location

Certifications and Complies:

- NEMA: 3

Standard Materials:

- Enclosure – *Feraloy*® iron alloy
- Plunger – steel
- Loop – bronze

Standard Finishes:

- *Feraloy* – electrogalvanized and aluminum acrylic paint
- Steel – electrogalvanized
- Bronze – natural



AFU mine signal switch with pushbutton switch (cover removed)

Ordering Information

Maximum Wt. of Line or Cable Without Actuating Switch (lbs.)	Total Operating Force Required (lbs.)	With Pushbutton Heavy Duty 600 VAC Max. Cat. #
25	50	AFU254
15	25	AFU154



Dimensions In Inches*:

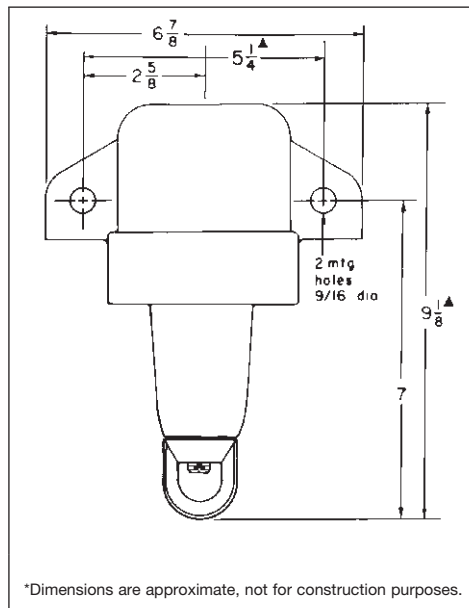

CHS Controls AB
 Florettgatan 33
 SE-254 67 Helsingborg, Sweden
 Tel +46 42 38 61 00, Fax +46 42 38 61 29
 chs@chscontrols.se
 www.chscontrols.se

FLEXITITE™ D2X Series Attachable Pendant Pushbutton Stations

For Class I, Div. 2 Areas

NEMA 3, 4X, 5, 6, 7BCD (Div. 2), 9FG (Div. 2), 12
Watertight
Raintight
Dust-tight
Wet Locations

5C

Applications:

FLEXITITE attachable pendant pushbutton stations are used:

- For safe multi-function motor circuit control of:
 - Hoists
 - Cranes
 - Machine Tools
 - Electromagnets
- In hazardous areas such as Class I, Division 2, Groups B, C and D (classified) areas or Class II, Division 2, Groups F and G, as defined by the National Electrical Code
- Where wash downs are necessary – in damp, wet, dirty or corrosive locations
- For control applications requiring 2 to 8 functions

Features:

- Safety cushioned – neoprene encapsulation protects internal switches and connectors from impact damage and provides extra protection for personnel.
- Stress relief for your cable is built-in. A separate cable grip is not needed.
- Uses Cooper Crouse-Hinds ESWP factory sealed contacts suitable for use in Class I, Division 2, Groups B, C and D
- Switches are rated for 10 amps 600 VAC (NEMA A600).
- Indicator plates meet OSHA requirements for clear identification of functions. A full set of plates is included with each station.
- Jam resistant operator buttons are raised flexible diaphragms – an integral part of the molded one-piece cover.
- Compact design
- Safety yellow finish.

Certifications and Compliances:

- NEMA: 3, 4X, 5, 6, 7BCD (Div. 2), 9FG (Div. 2), 12
- UL Standard: 1203
- CSA Standard: C22.2 No. 30

Standard Materials:

- Body and cover – steel reinforced neoprene
- Strain relief and reinforcement plates – stainless steel
- Exterior hardware – stainless steel

Standard Finishes:

- Neoprene – safety yellow
- Stainless steel – natural

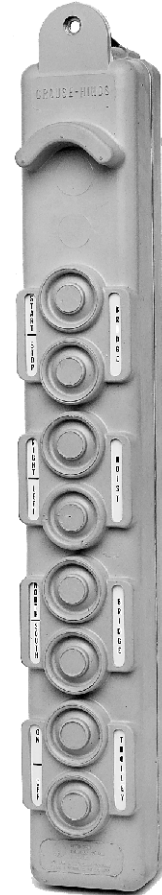

8-Button Control Station

5C



CHS Controls AB

Florettgatan 33
SE-254 67 Helsingborg, Sweden
Tel +46 42 38 61 00, Fax +46 42 38 61 29
chs@chscontrols.se
www.chscontrols.se

FLEXITITE™ D2X Series Attachable Pendant Pushbutton Stations

For Class I, Div. 2 Areas

NEMA 3, 4X, 5, 6, 7BCD (Div. 2), 9FG (Div. 2), 12
Watertight
Raintight
Dust-tight
Wet Locations

Ordering Information

Pendant Pushbutton Stations

Description	Cable Dia.	Cat. #
2-Button	.31 – .75	D2X8635 210
4-Button	.50 – .75	D2X8635410
6-Button	.59 – .81	D2X8635 610
8-Button	.59 – .92	D2X8635 810

Replacement Indicator Plates (A full set is included with each control station)

2-Button

Cat. #	Description	Cat. #	Description
315116 1	Down/West	315116 7	Rev/Left
315116 2	Start/North	315116 8	Up/East
315116 3	Stop/South		
315116 4	Off/In		
315116 5	On/Out		
315116 6	Fwd/Right		

4, 6 and 8-Button

Cat. #	Description	Cat. #	Description
314850 1	Bridge	314850 6	Fwd/Rev North/South
314850 2	Trolley	314850 9	On/Off Start/Stop
314850 3	Hoist		
314850 4	In/Out Up/Down Right/Left		
314850 5	East/West		

Replacement Switch

Description	Cat. #
Replacement Switch	ESWP126

5C



CHS Controls AB
 Florettgatan 33
 SE-254 67 Helsingborg, Sweden
 Tel +46 42 38 61 00, Fax +46 42 38 61 29
 chs@chscontrols.se
 www.chscontrols.se

Dimensions

In Inches:

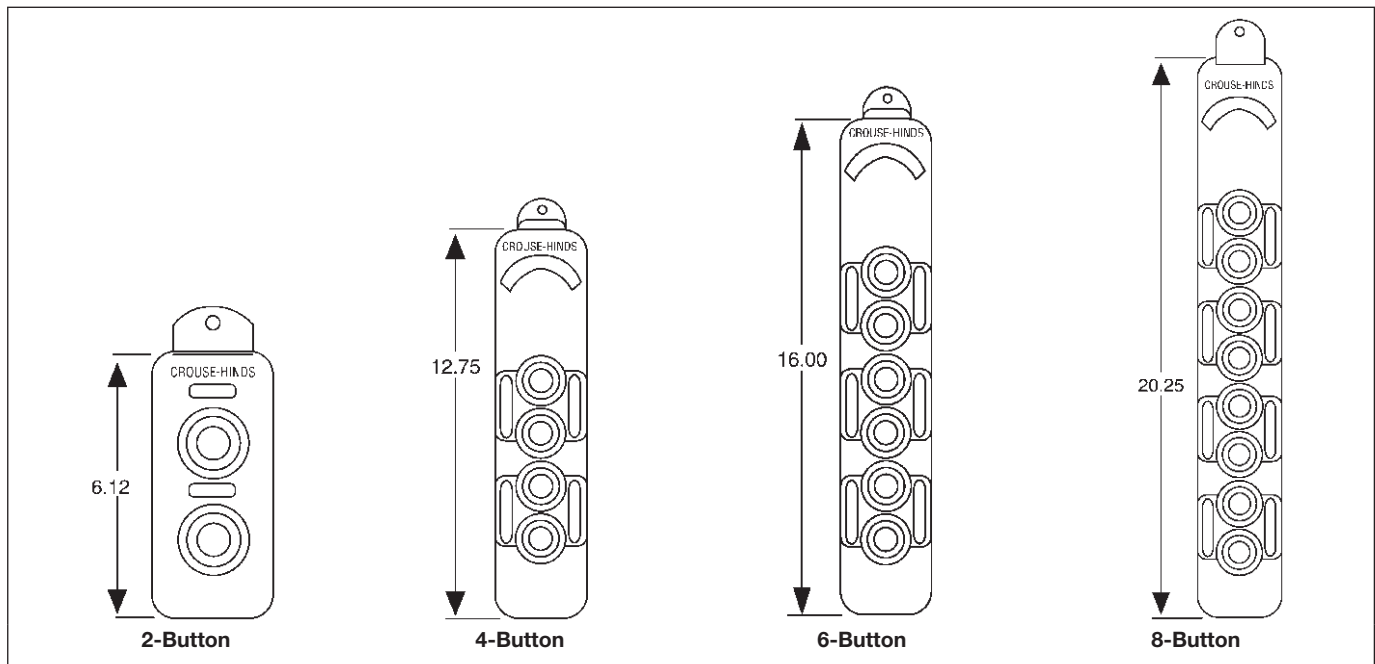

Applications:

FLEXITITE attachable pendant pushbutton stations are used:

- For safe, multi-function motor circuit control of:
 - Hoists
 - Cranes
 - Machine Tools
 - Electromagnets
- Non-hazardous control environments requiring from 2 to 8 functions.
- Where washdowns are necessary – in damp, wet, dirty, or corrosive locations.

Features:

- Safety insulated to meet OSHA requirements for enclosing live parts. The entire unit except the strain relief is insulated with neoprene.
- Safety cushioned – neoprene encapsulation protects internal switches and connectors from impact damage and provides extra protection for personnel.
- Stress relief for your cable is built-in. A separate cable grip is not needed unless the optional pilot light kit is used.
- Positive action long life momentary contact switches.
- Maintained Off-On toggle switch is optionally available on 4, 6, and 8 button units.
- Jam resistant operator buttons are raised flexible diaphragms – an integral part of the molded one-piece cover.
- Compact – 3" x 3" enclosure easily fits your hand.
- Indicator plates meet OSHA requirements for clear identification of functions. A full set of plates is provided with each station.

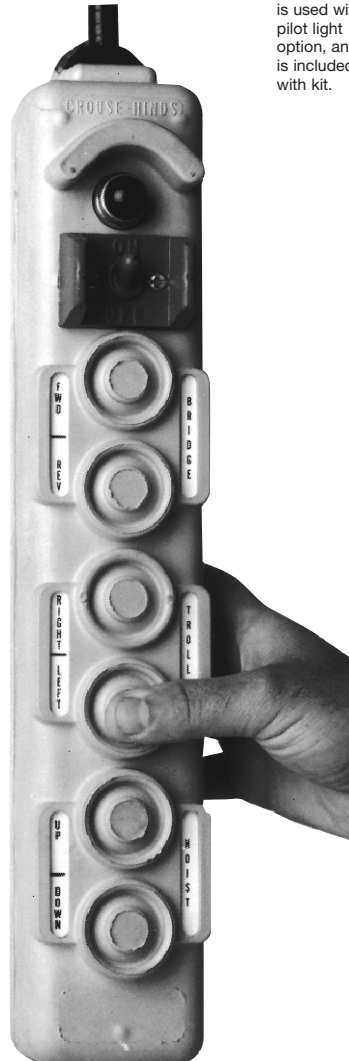

A cable grip is used with pilot light option, and is included with kit.

Inside Front View

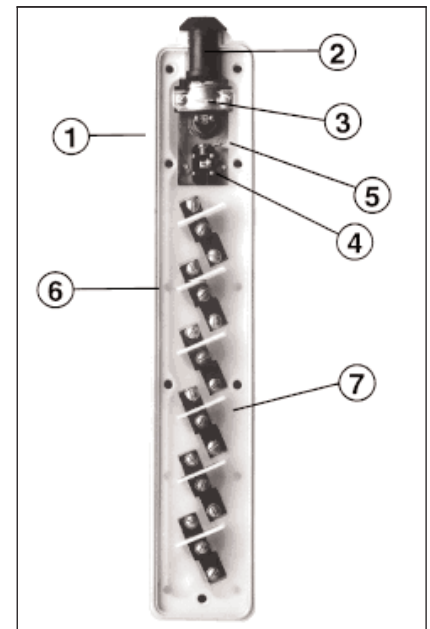

1. **BODY SEAL** – Compresses against mating half to form a positive seal.
 2. **REDUCING GROMMETS** – Permit use of five different cable sizes while sealing cable entrance.
 3. **CABLE CLAMP** – Secures conductors inside switch. Transfers strain to inner steel core of switch. (Not used with pilot light.)
 4. **TOGGLE SWITCH (OPTIONAL)** – Maintained off-on switch to control power to pendant stations.
 5. **GREEN GROUNDING SCREW** – Makes positive contact between inner steel core and ground wire.
 6. **INSULATION BARRIERS** – On 4- and 6-button models. Position switches and separate N.O. and N.C. switch contacts for added safety.
 7. **SEPARATOR** – For 4- and 6-button models. Tough polypropylene sheet retains switches and forms an insulated wiring channel.
- STRAIN RELIEF** – Integral part of the inner steel core – provides tie-off point for strain chain to relieve tension from electrical cable.
- ELECTRICAL INTERLOCK** – Schematic furnished to wire switches against opposed operations.
- LOW COST, EASILY INSTALLED** – Despite their many advantages, Cooper Crouse-Hinds pendant stations generally cost less than similar metal units.
- RAISED BUMPER** – protects lens against damage caused by impact.

Certifications and Complies:

- NEMA: 3, 4X, 5, 6, 12
- UL Standard: 508
- CSA Approved

Standard Materials:

- Body and cover – steel reinforced neoprene
- Strain relief and reinforcement plates – stainless steel
- Exterior hardware – stainless steel





Standard Finishes:

- Neoprene – safety yellow
- Steel – stainless steel



CHS Controls AB
 Florettgatan 33
 SE-254 67 Helsingborg, Sweden
 Tel +46 42 38 61 00, Fax +46 42 38 61 29
 chs@chscontrols.se
 www.chscontrols.se

Ordering Information - One and Two Speed 2, 4, 6 and 8 Buttons

Style	Switch*	Speed			Cable Diameter	Shipping Weight (lbs.)	Dimensions		
		20A 460V 2 hp. 230V	10A 230V ½ hp. 230V	DC 10A 125V ⅛ hp. 125V			Length	Width	Depth
2-Button									
	None	X8635 21	X8635 22	X8635 20	.555 thru .665	2½	8¾"	2¼"	3"
4-Button									
	3316317	X8635 41B	X8635 42B	X8635 40B	.505 thru .730	3	13½"	3"	3⅝"
6-Button									
	3316317	X8635 61B	X8635 62B	X8635 60B	.590 thru .840	6½	17"	3"	3⅝"
8-Button									
	3316317	X8635 81	X8635 82§	X8635 80	.698 thru .968	9	21½"	3"	3⅝"

*Should be ordered separately.
§2 speed includes: 6, 2-speed switches and 2, single speed switches.

Pilot Light Kit for 4, 6 and 8-Button Only

Lamp Voltage	Cable Diameter			
	4 and 6 Button		8 Button	
110-125V AC	3316533	3316533 1	3316533 2	3316624
210-250V AC	3316534	3316534 1	3316534 2	3316625

Pilot light kit includes: lamp assembly with lens and bulb, cable support grip, and "S" hook. Support grip and "S" hook not required on 8-button. NEMA 3,4,5,12 only.

FLEXITITE™ 2-Button Attachable Pendant Switch

Cat. #	Contact Style	Voltage	Amps Make	Amps Break
X8995 1	Momentary Switch	240 AC	7.5	0.75
Yellow		120 AC	15.0	1.5
		24 AC	15.0	2.5
		250 VDC	0.27	0.27
		125 VDC	.055	0.55



Indicator Plates (Replacement only – units come with plates standard)

2-Button				4, 6 and 8-Button			
Cat. #	Description	Cat. #	Description	Cat. #	Description	Cat. #	Description
315116 1	Down/West	315116 7	Rev/Left	314850 1	Bridge	314850 6	Fwd/Rev. (North/South)
315116 2	Start/North	315116 8	Up/East	314850 2	Trolley	314850 9	On/Off (Start/Stop)
315116 3	Stop/South	315116 9	Raise/Lower	314850 3	Hoist	314850 12	Raise/Lower
315116 4	Off/In	315116 10	Up/Down	314850 4	In/Out (Up/Down)	314850 13	Inbd/Outbd
315116 5	On/Out	315116 11	Right/Left	314850 5	Right/Left (East/West)	314850 14	Off/On
315116 6	Fwd/Right						

Shoulder Bolts for Fastening Front to Back Cover – 2-Button (P/N 1316311-2); 4- & 6-Button (P/N 1316311-1); 8 button (P/N 1316311-3).
NOTE: Refer to price list for identification of stock items.

Replacement Parts

Style	Cat. #		Switch Element Part Numbers					Parts Kit‡	Pilot Light Kit		
	Front Cover	Back Cover	Toggle Switch Kit†	1 Speed 20A, 460V 2hp, 230V	2 speed 10A, 230V ½ hp. 230V	DC 10A, 125V ⅛ hp. 125V	Toggle Off/On Element			Barrier	Separator
2-Button	A335578	A335577 1	Not Avail.	3316480	314896	314903				RX8635 21	
4-Button	3335848 1	3335829 1	3316317	3316480	314896	314903	1316313	314849 1 (4 Req'd)	335616 (1 Req'd)	RX8635 41	See Above Chart
6-Button	3335845 1	3335830 1	3316317	3316480	314896	314903	1316313	314849 1 (6 Req'd)	335571 (1 Req'd)	RX8635 61	
8-Button	3344153	3344154	3316317	3316480	314896	314903	1316313	Not Req'd	Not Req'd	RX8635 80	

†Toggle switch kit – includes: toggle switch, guard, assembly and screws.
‡Parts kit – includes cable grommets, legend plates and assembly screws.



CHS Controls AB
 Florettgatan 33
 SE-254 67 Helsingborg, Sweden
 Tel +46 42 38 61 00, Fax +46 42 38 61 29
 chs@chscontrols.se
 www.chscontrols.se

EGF Series Ground Fault Control Station

Cl. I, Div. 1 & 2, Groups C, D Explosionproof
Cl. II, Div. 1, Groups E, F, G Dust-Ignitionproof
Cl. II, Div. 2, Groups F, G Raintight
Cl. III Wet Locations
NEMA 3, 7CD, 9EFG, 12

5C

Applications:

EGF Series of control stations are used:

- For the additional safety of personnel, and for equipment protection in remote areas.

Features:

- Copper-free aluminum construction offers lightweight, corrosion resistance and a long, maintenance-free service life.
- 1 1/4" throughfeed conduit hubs with 1 1/4"-1" reducers for ease of installation.
- Compact, internally flanged enclosure requires minimum installation area.
- Steel mounting feet with electroplate finish for fast, secure, and corrosion-resistant mounting.
- Accepts #14-#10 copper wire sizes for application flexibility.
- Push-to-test button and pilot light (with 10,000 hour incandescent lamp) for easy and constant operational monitoring of unit.
- Cast aluminum circuit breaker operating handle for durability during use.
- EPD breakers for protection of heat tracing circuits.

Certifications and Complies:

- NEC:
 - Class I, Div. 1 & 2, Groups C, D
 - Class II, Div. 1, Groups E, F, G
 - Class II, Div. 2, Groups F, G
 - Class III
- NEMA 3, 7CD, 9EFG, 12

Standard Materials:

- Bodies, covers, threaded barrels, guards, collars, and toggle operator – copper-free aluminum
- Pushbuttons – type 6 / 6 nylon
- Operating shafts – stainless steel

Standard Finishes:

- Copper-free aluminum – natural
- Sheet steel – zinc electroplate with chromate finish
- Stainless steel – natural

Electrical Rating:

- GFI, EPD breakers – 120 VAC (single pole), 120 / 240 VAC for two pole (10,000 AIC)



Ordering Information

Number of Breakers	Number of Poles	Milliamp Trip	Cat. #
1	1	5	EGF11 ①
1	2	5	EGF12 ①
2	1	5	EGF21 ①
1	1	30	EGF11EPD ①
1	2	30	EGF12EPD ①
2	1	30	EGF21EPD ①

①Add 15, 20, 25, or 30 amp breaker rating.

Dimensions In Inches:

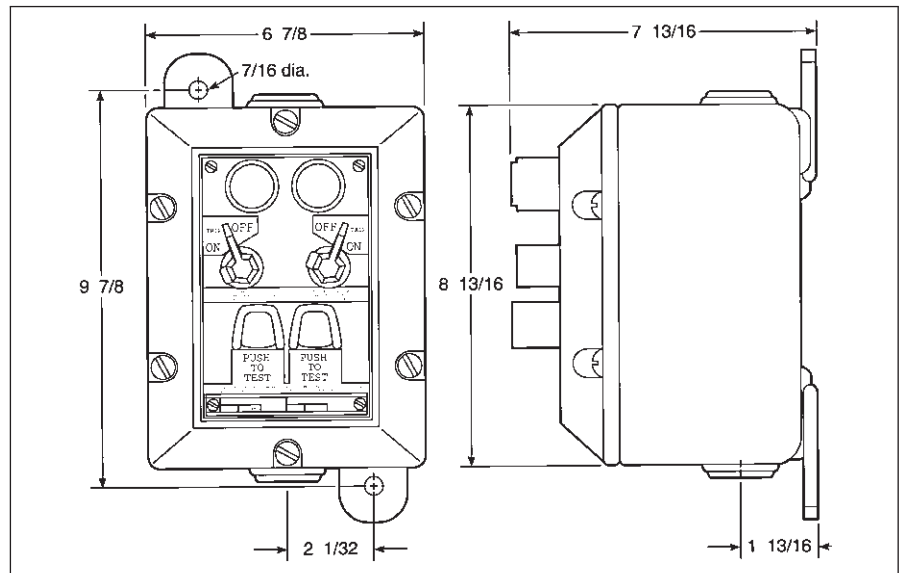



CHS Controls AB
 Florettgatan 33
 SE-254 67 Helsingborg, Sweden
 Tel +46 42 38 61 00, Fax +46 42 38 61 29
 chs@chscontrols.se
 www.chscontrols.se

**CHS Controls AB**

Florettgatan 33
SE-254 67 Helsingborg, Sweden
Tel +46 42 38 61 00, Fax +46 42 38 61 29
chs@chscontrols.se
www.chscontrols.se

Description	Page No.
Explosionproof VFDs - Class I, Division 1 & 2 ACE Series	see page 582

6C

 **CHS Controls AB**
Florettgatan 33
SE-254 67 Helsingborg, Sweden
Tel +46 42 38 61 00, Fax +46 42 38 61 29
chs@chscontrols.se
www.chscontrols.se

The only explosionproof VFD solution utilizing NEMA 7 with active cooling

Cooper Crouse-Hinds Explosionproof VFDs are highly flexible AC drives designed specifically for hazardous area locations. These drives can be mounted next to the motor in the classified area, providing significant installation cost savings - along with the traditional VFD benefits of energy savings, speed and torque control, and system diagnostics.

This Cooper Crouse-Hinds innovative product features the first ever NEMA 7 enclosure with active cooling, allowing the solution to be rated Class I, Divisions 1 and 2.

Applications:

- Designed to match the high requirements of process industries, such as oil and gas, chemical, and mining
- Pumps, compressors, fans, separators, and mixers

VFD Benefits:

Improved Process Control

- Fine speed and torque control
- Soft start capability
- Improved pressure, flow, and motion control

Reduced Operation and Installation Costs

- Locate VFD in classified area, eliminating costly conduit/cable tray runs
- Eliminate control valves
- Reduced energy consumption
- No additional space required in sub-station
- Extract equipment condition and operating information
- Lower pump maintenance costs

Reliable Performance in Any Environment

- Recommended temperature range: 0°C to 50°C (consult factory for more extreme temperature guidance)
- Class I, Divisions 1 and 2
- Raintight, wet locations

Certifications and Compliances:

- UL Listed
Class I, Division 1 and 2, Groups B, C, D
- Standards
UL 1203
cUL: CSA 22.2 No. 30 M1986
- Environmental
NEMA 3, 4X, 7, 9
Raintight
Wet locations

Standard Materials

- Enclosure - epoxy powder coated copper-free aluminum
- Internal Mounting Brackets - natural copper-free aluminum and natural stainless steel
- Hinges, Hardware, Filter Assemblies - natural stainless steel
- Gaskets - neoprene
- Glass - tempered soda lime

Horsepower Ratings:

- Available up to 60HP
- Higher HP ratings coming soon

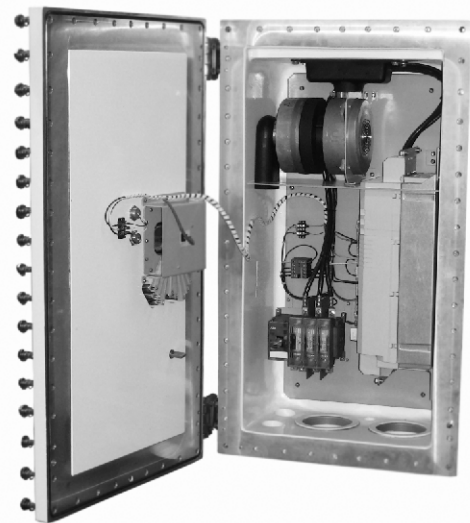
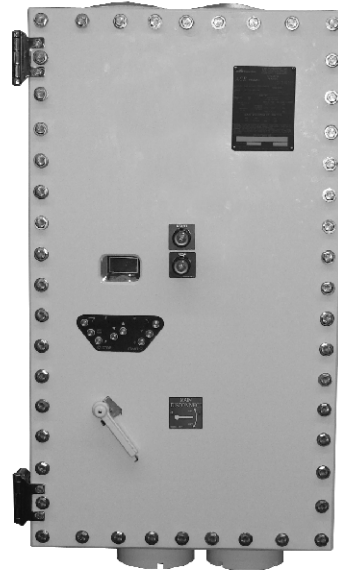

CHS Controls AB

Florettgatan 33
 SE-254 67 Helsingborg, Sweden
 Tel +46 42 38 61 00, Fax +46 42 38 61 29
 chs@chscontrols.se
 www.chscontrols.se

ACE Series Explosionproof Variable Frequency Drives

Cl. I, Div. 1 and 2, Groups B, C, D
UL Listed

NEMA 3, 4X, 7, 9
Raintight
Wet Locations

6C

Multiple Patents Pending

Ordering Information:

Catalog Number	Disconnect Rating (Amps)	Disconnect Fuse Type	Enclosure Size	Input Rating (Amps)	Nominal Horsepower	Output Rating (Amps) 0°C to 25°C	Output Rating (Amps) 25°C to 40°C	Output Rating (Amps) 40°C to 50°C	Weight
ACE10 1 3				2.3	1.0	2.80	2.5	2.3	257
ACE10 2 3				3.1	2.0	3.40	3.0	2.8	257
ACE10 2 5				4.0	2.0	4.50	4.0	3.7	257
ACE10 3 6	30	J	1	5.5	3.0	5.50	4.8	4.6	257
ACE10 5 8				6.6	5.0	7.60	6.7	6.3	257
ACE10 5 10				8.7	5.0	9.70	8.5	8.1	262
ACE10 8 13				12	7.5	13.0	11.4	10.8	262
ACE10 10 17				16	10	16.8	14.8	13.9	262
ACE10 15 23				20	15	23	20	19	384
ACE10 20 28				26	20	28	25	23	384
ACE10 20 32	60	J	2	30	20	32	28	27	384
ACE10 30 41				36	30	41	36	34	384
ACE10 30 46				42	30	46	40	38	384
ACE10 40 57				55	40	57	50	47	397
ACE10 50 74	100	J	2	65	50	74	65	61	397
ACE10 60 90				82	60	90	79	75	397

Data in shaded area is a preliminary approximation. Contact factory for final numbers.

Options

Description	add suffix
Communication Modules	
Profibus	CP
Devicenet	CD
CAN Open	CC
Modbus	CM
Ethernet	CE
Potentiometer	
AB 800H	POT

Example: ABB 60HP VFD, 90 continuous amps at ambient of less than 25°C, with Ethernet Communications and a Potentiometer in cover.

ACE10 60 90 CE POT



CHS Controls AB
 Florettgatan 33
 SE-254 67 Helsingborg, Sweden
 Tel +46 42 38 61 00, Fax +46 42 38 61 29
chs@chscontrols.se
www.chscontrols.se

**CHS Controls AB**

Florettgatan 33
SE-254 67 Helsingborg, Sweden
Tel +46 42 38 61 00, Fax +46 42 38 61 29
chs@chscontrols.se
www.chscontrols.se

Description	Page No.
Switch Racks	
General Information	see pages 586–589
Bus Duct Assemblies	see pages 590–591
Selection Guide	see pages 592–594



CHS Controls AB
Florettgatan 33
SE-254 67 Helsingborg, Sweden
Tel +46 42 38 61 00, Fax +46 42 38 61 29
chs@chscontrols.se
www.chscontrols.se

Cl. I, Div. 1 & 2, Groups B, C, D

Cl. II, Div. 1, Groups E, F, G

Cl. II, Div. 2, Groups F, G

Cl. III

NEMA 3, 4X, 7BCD, 9EFG, 12

Explosionproof

Dust-Ignitionproof

Raintight

Wet Locations

Watertight

Applications:

Free-standing switch rack assemblies are used:

- To provide a complete motor control center in one integrated package
- Outdoors and indoors
- In damp, wet or corrosive locations such as sewage treatment plants, lumber mills, marine installations, and food preparation areas
- In areas made hazardous due to the presence of flammable vapors or gases, such as petroleum refineries, chemical and petrochemical plants, gas gathering plants, pipeline compressor stations, and drilling rigs, both onshore and offshore
- In areas where hazardous dusts are present, such as coal handling facilities, grain processing and handling plants, and certain food process industries

Features:

- Complete factory assembled and wired switch racks
- Pre-drilled bus boxes allow for quick and easy changing or adding of components
- Complete assembly covered under one order, eliminates engineering costs, additional costs of placing separate orders with several vendors for various components, and assembly and scheduling problems at job site
- Wiring is simple. After switch rack is in place, feeders are connected to the main bus and connections made from starters motors. No other field wiring is necessary
- Maintenance time and costs are reduced by having controls grouped. Work is performed in one location instead of moving from one control to another in various locations
- Major components are standard EBM, EPC, NMC, NMG, NCB, FLB, D2PB, EXD, D2D, EPL, and D2L enclosures featuring ready access to starters and breakers for inspection and maintenance
- Custom built racks to meet your exact requirements are a Cooper Crouse-Hinds specialty. Complete quotations will be supplied for any job, large or small (38' length max)

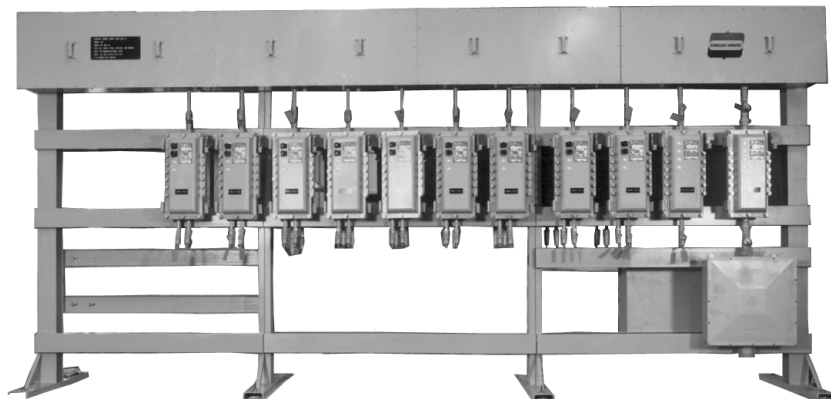

Certifications and Complies:

- NEC:
 - Class I, Divisions 1 & 2, Groups C, D (Group B optional)
 - Class II, Division 1, Groups E, F, G
 - Class II, Division 2, Groups F, G
 - Class III
- NEMA: 3, 4X (optional), 7B (optional) CD, 9EFG, 12

Standard Materials:

- Rack frames – structural steel or aluminum channel members, bolted and welded
- Components – see sections A & C for material

Standard Finishes:

- Rack frame – hot dip galvanized steel or natural aluminum
- Components – see sections A & C for finishes

Options:

- Rack frame finish – corrosion resistant primer with air dry epoxy
- Options listed for individual components can be incorporated in complete switch racks



CHS Controls AB

Florettgatan 33
SE-254 67 Helsingborg, Sweden
Tel +46 42 38 61 00, Fax +46 42 38 61 29
chs@chscontrols.se
www.chscontrols.se

Construction:

General:

- All construction to be in accordance with current National Electrical Code® (NEC), National Electrical Manufacturers' Association (NEMA), state and local standards as designated by the purchaser.
- All hazardous area enclosures for motor starters, combination motor starters, circuit breakers, motor circuit protectors, instrument enclosures, panelboards, main bus, fittings, receptacles, and lighting fixtures shall be made and supplied by the manufacturer.
- All explosionproof threaded enclosures for combination starters, circuit breakers, motor circuit protectors, and starters shall be UL classified.
- All other standard hazardous area enclosures shall be UL listed or UL classified.
- Motor control racks shall be constructed by an approved union shop.
- Manufacturer shall retain permanent records of all motor control racks and shall have the capability of duplicating, or replacing, any fully-assembled rack or rack component.
- Manufacturer to assume responsibility for construction, purchase/manufacturer of components, complete circuit continuity testing, and testing of mechanical functions of components.

Rack Frame Design:

Structure:

- Switch rack, either single or double face as required, shall be rigid, free-standing structures. Racks shall be factory-welded, assembled and fabricated from standard rolled structural steel or aluminum shapes.
- Vertical risers will be 6" I-beam and horizontal members shall be 6-inch channel.
- Mounting feet shall be 6-inch channel. Width of such feet for single-sided racks shall be 41 inches.
- End mounting feet will be braced (welded) to the upright with 6" T member.
- Mounting feet shall be anchored at the job site with 1-inch diameter bolts. Anchor bolts and mounting pads will be the responsibility of the user.
- Maximum horizontal spacing between mounting legs shall not exceed 6 feet. (Specific dimensions to be determined by the manufacturer.)
- Racks longer than 20 feet will be supplied as bolt-together sections. (Specific section dimensions to be determined by the manufacturer.)

Grounding:

- A pressure-type grounding lug with appropriate wire capacity will be provided at each end of frame.

Finish:

- Rack frame shall be hot-dip galvanized after fabrication or natural aluminum.

Main Bus Equipment:

Class I, Division 1:

- Main bus material shall be copper only and capable of withstanding up to 65K amps fault current. Cable bus will be wired to terminal blocks enclosed in cast, copper-free aluminum, explosionproof junction boxes, Cooper Crouse-Hinds type EJB. Such junction boxes for incoming power and distribution wiring shall be provided at either the top or bottom of the rack. Enclosures shall be connected by rigid conduit with conduit seals installed in accordance with the NEC. Load conduit or cable will leave rack either below or above. Manufacturer shall provide conduit layouts.

Class I, Division 2:

- Main bus material shall be copper only and capable of withstanding up to 65K amps fault current. Cable bus will be wired to terminal blocks enclosed in cast, copper-free aluminum weathertight junction boxes, Cooper Crouse-Hinds type WJB. Such junction boxes for incoming power and distribution wiring shall be provided at either the top or bottom of the rack. Enclosures shall be connected by rigid conduit with conduit seals installed as required by the NEC. Load conduit or cable will leave rack either below or above. Manufacturer shall provide conduit layouts.

Bus Duct in Lieu of Junction Boxes (Optional):

- Cable bus will be wired to a weathertight bus duct provided at the top or bottom of the rack.

Canopy (Optional):

- Single- or double-pitched canopy shall have minimum 15-degree pitch with a minimum 7'6" ground clearance, and 2-foot overhang. Roofing material shall be corrugated aluminum. Canopy roof trusses, cross channels, roof material, and mounting hardware shall be shipped unassembled for quick assembly at the job site. All holes in structure shall be provided except for roof mounting holes which will be drilled in the field. Manufacturer will supply drawings and material for complete field assembly of canopy.

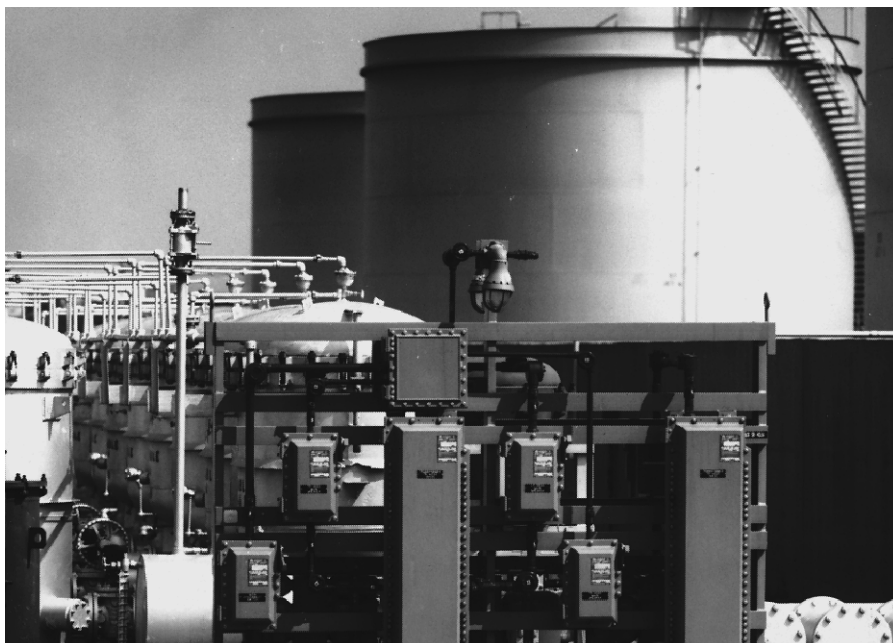

Cooper Crouse-Hinds switch rack installed in a fuel storage area.



CHS Controls AB

Florettgatan 33
 SE-254 67 Helsingborg, Sweden
 Tel +46 42 38 61 00, Fax +46 42 38 61 29
 chs@chscontrols.se
 www.chscontrols.se

Motor Control Components:

Explosionproof Quick Opening Enclosures:

- All circuit breakers, motor circuit protectors and combination or across-the-line motor starters shall be enclosed in quick-opening enclosures (Cooper Crouse-Hinds types EBM or EPC).

Types:

- Ground joint bolted cover enclosure shall be Cooper Crouse-Hinds type EBM, Underwriters Laboratories Inc. classified for use in Class I, Groups C, D, Divisions 1 and 2, Class II, Groups E, F, G, Divisions 1 and 2 and Class III hazardous locations and shall also be suitable for Type 3, 3R and/or Type 4 (NEMA 3, 3R and 4) areas.
- All enclosures shall be cast of a corrosion-resistant copper-free aluminum alloy (less than 0.4% copper) and shall be of a semi clamshell design with external flange to promote ease of apparatus installation, adjustment and maintenance. Most importantly, enclosure inside dimensions shall conform to the wire bending space requirements of the National Electrical code NFPA70 paragraph 373-6. Enclosures with flat covers, internal flanges or those not conforming to NFPA70 paragraph 373-6 are not permitted.
- Covers shall be hinged on the left side and, when closed, shall be affixed to the body by multiple lead thread bolts to promote quick opening and closing of the enclosure.
- Cover bolts shall be hex head stainless steel without screwdriver slots, to promote the use of a socket or wrench for proper tightening. They shall be captive to the cover and stainless steel spring loaded to indicate the fully unthreaded position. Spring loading shall give visual indication that the bolts are free of the body when the cover is being opened. The cover flange ground joint shall have an integral gasket to prevent the entry of windblown dust, rain or sleet.
- All enclosures shall be fitted, as standard, with adjustable, extended, corrosion-resistant, copper-free aluminum hinges that shall allow the cover to swing away from the body when opened and shall permit unobstructed working space for maintenance, adjustment or replacement of the internal apparatus. Additionally these hinges shall allow minimum enclosure-to-enclosure spacing with little interference between an open cover and an adjacent enclosure. Enclosures with hinges fabricated from steel or aluminum stampings shall not be permitted.
- All enclosures shall be provided with drilled, tapped and plugged conduit entrances suitably sized for the electrical application. Power conduit entrances shall be located 1 (or 2) each on (or equally spaced from) the enclosure vertical centerline at top and bottom. A single, plugged 1" entrance for a control conduit shall be provided at the bottom of the enclosure. (Some enclosures can also be provided with a plugged 1" entrance for control conduit at the top.)
- All conduit entrances shall be furnished with removable copper-free aluminum reducers, each with integral wire pulling bushing. All conduit entrances shall be located the same distance from the enclosure mounting surface to facilitate conduit run layout and/or stub up construction.
- All enclosures shall have rugged, cast copper-free aluminum circuit breaker and motor starter overload reset operating handles located on the right side of the enclosure. These handles shall operate the internal mechanisms via stainless steel, gasketed shafts and bearings through the side wall of the body. Correct circuit breaker and overload reset operation shall be visually confirmed with the cover open.
- Circuit breaker handles shall be padlockable in either the "OFF" or "ON" position, and shall be trip-free of the circuit breaker itself. An attached indicating plate shall give clear, visual confirmation of the circuit breaker status.
- Adjustable circuit breaker handle stops shall be provided to ensure full operation of the circuit breaker and to prevent handle overthrow that could damage the circuit breaker toggle.

- Motor starter overload reset operating mechanisms shall be field adjustable.
- Threaded construction enclosures shall be Cooper Crouse-Hinds type EPC, Underwriters Laboratories, Inc. classified for use in Class I, Groups C, D, Divisions 1 and 2, Class II, Groups E, F, G, Divisions 1 and 2 and Class III hazardous locations and shall also be suitable for Type 3, 3R and/or Type 4 (NEMA 3, 3R and 4) areas.
- All enclosures shall be cast of a corrosion-resistant copper-free aluminum alloy (less than 0.4% copper) and shall be of a three section design. Multiple-start straight buttress threads between the covers and the body shall ensure quick access to the interior in less than two full turns of the covers. A system of stops shall prevent overtightening and thread seizing. A system of locks shall prevent covers from loosening due to external vibration.
- Female threads on the top cover with male threads on the bottom cover shall ensure inherent water and rain shedding.
- All exposed screws, bolts and hardware shall be stainless steel.
- The external circuit breaker operating handle affixed to a stainless steel shaft, shall be padlockable in either the "ON" or "OFF" position with up to three padlocks. Circuit breaker mechanisms shall be trip-free of the circuit breaker itself to allow the circuit breaker to open under overload conditions even if it is locked in the "ON" position.
- The mounting bracket shall provide a three-point suspension system for quick installation and adjustment.
- Conduit entrances shall have integral wire pulling bushings and conduit stops. These openings shall be arranged two at the top and two at the bottom and shall be sized for power and control requirements.

General:

- All enclosures shall be bolted to the horizontal frame members on either the front or back or both front and back. Enclosures shall be connected to the main bus via conduit seals. (To be field poured). All hardware used to mount the enclosures shall be stainless steel.



CHS Controls AB
 Florettgatan 33
 SE-254 67 Helsingborg, Sweden
 Tel +46 42 38 61 00, Fax +46 42 38 61 29
 chs@chscontrols.se
 www.chscontrols.se

Lighting Panelboards:

Class I, Division 1:

- Panelboards shall be Cooper Crouse-Hinds type, factory-sealed EXD or EPL as specified and shall meet the following electrical ratings:
 - EPL – 1, 2 or 3 pole, 240 volt maximum, 100 amp maximum branch trip rating, 10,000 AIC.
 - EXD – 1, 2 or 3 pole, 600 volt maximum, 100 amp maximum branch trip rating.

Class I, Division 2:

- Lighting panelboard shall be Cooper Crouse-Hinds type D2L factory-sealed, 120 / 240 volt panelboards and be provided with single-pole, two-pole, or three-pole branch circuit breakers with up to 100 amp trip rating; main breaker ranging to 225 amp. Similarly, lighting panelboard shall be type D2PB factory-sealed, 120 / 240 volt panelboards and be provided with single-pole or two-pole factory sealed circuit breakers with 15, 20 or 30 amp trip ratings and maximum 10,000 AIC. Power panelboards type D2D factory-sealed, up to 600 volt are provided with single-pole, two-pole, or three-pole branch circuit breakers with up to 100 amp trip ratings; main breaker rating to 225 amp.

NEMA 4X Option:

- All bus boxes, control enclosures and lighting panelboards will be made of *KRYDON*® material to meet NEMA 4X requirements.

Fittings:

- All fittings shall be made and provided by the manufacturer. Seals and unions will be provided for each incoming and outgoing conduit as required. All interconnections between components shall be done by the manufacturer with galvanized rigid conduit, and conduit fittings as required to meet the hazardous classification. Interconnecting conduits to be provided with conduit seals as required. All incoming and outgoing rack conduit entrances shall include conduit seals as required by the hazardous location specified. Such seals will be provided by the manufacturer and will not be filled where field wiring is to be introduced.

Conduit Boxes, Outlet Boxes, Device Boxes:

- Conduit boxes, outlet boxes, and device boxes shall be Cooper Crouse-Hinds *Condulet*® fittings.

Seals:

- Seals will be standard Cooper Crouse-Hinds type *Condulet* EYS. (Cooper Crouse-Hinds *Condulet* EYD drains to be specified as required.)

Unions:

- Unions will be Cooper Crouse-Hinds UNY.

Breathers and Drains:

- Breathers and drains shall be Cooper Crouse-Hinds ECD.

Wiring:

- Standard wire shall be copper only, 600 volt, 75°C minimum rating, UL listed.
- No power wire less than 12AWG shall be used.
- Control wire shall be 14AWG minimum, 7 strands, THW minimum.
- Wiring shall be sized in accordance with the NEC requirements.

Drawings:

- Standard drawings supplied for customer approval shall include complete rack wiring diagram, component data, nominal weight of the rack, and overall rack dimensions.

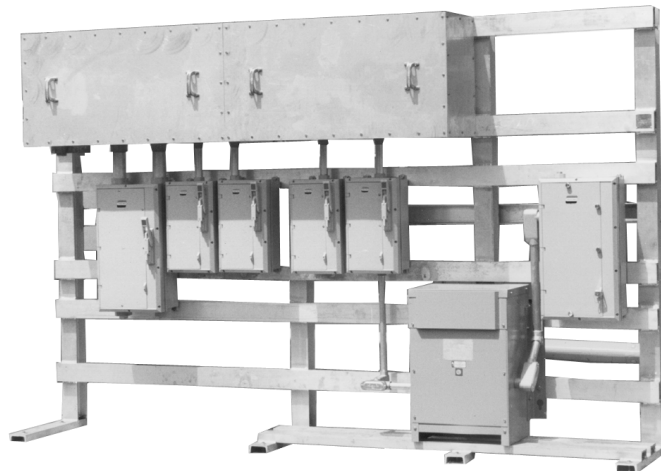

CHS Controls AB

Florettgatan 33
 SE-254 67 Helsingborg, Sweden
 Tel +46 42 38 61 00, Fax +46 42 38 61 29
 chs@chscontrols.se
 www.chscontrols.se

Applications:

- Cooper Crouse-Hinds is now offering NEMA 3R, UL Listed Bus Duct (Termination Box) Assemblies as standard product. Up to 600V, three-phase, 3 or 4 wire, 400Amp or 600Amp service with short circuit ratings of 25K or 50K.
- Bus ducts or termination boxes provide a means of tapping feeder circuits for power distribution on outdoor switchrack assemblies or indoor wall-mounted applications.
- Typical application is primarily for bus replacements on existing switchrack installations. New applications may include on-site construction of switchracks or indoor feeder distribution points due to space confinements making local installation more practical.

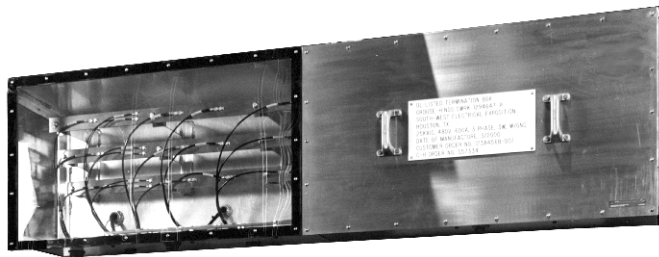

Features:

- UL Listed.
- NEMA 3R.
- Maximum voltage rating 600V.
- 400Amp or 600Amp @ 25KAIC or 50KAIC.
- External flange on bus duct enclosure and lip on covers prevents water leakage and allows covers to hang freely for ease of installation and maintenance.
- 3 degree pitch at top, for water run-off, on all flush mounted bottom entry designs.
- Chorosulfonated polyethylene (Hypalon®) gasket material at all bus box section joints, covers and end plates.
- Standoff (Glastic) insulators moulded of (UL) recognized flame-resistant fiberglass-reinforced thermoset polyester moulding compound.
- Bus bar sizing and bracing complies to UL857 requirements.
- All welded construction - sheet aluminum, sheet steel (galvanized), or stainless steel.
- Stainless steel hardware throughout.
- Two hole compression lugs at all power phase connectors attached with stainless steel hardware.
- One (1) drain is standard per bus duct section (typical 4 foot sections).
- Solid copper bus bars (tin, silver plated and/or insulated – optional per customer request).
- Solid copper ground bar – standard.
- Incoming main lugs – supplied size and location specified with customer.
- Space heaters – optional per customer request.
- Pre-drilled copper bars (when specified by customer).
- Conduit entries for Myers hubs – optional per customer request.



CHS Controls AB

Florettgatan 33
SE-254 67 Helsingborg, Sweden
Tel +46 42 38 61 00, Fax +46 42 38 61 29
chs@chscontrols.se
www.chscontrols.se

Bus Duct (Termination Box) Catalog Numbering System

7C

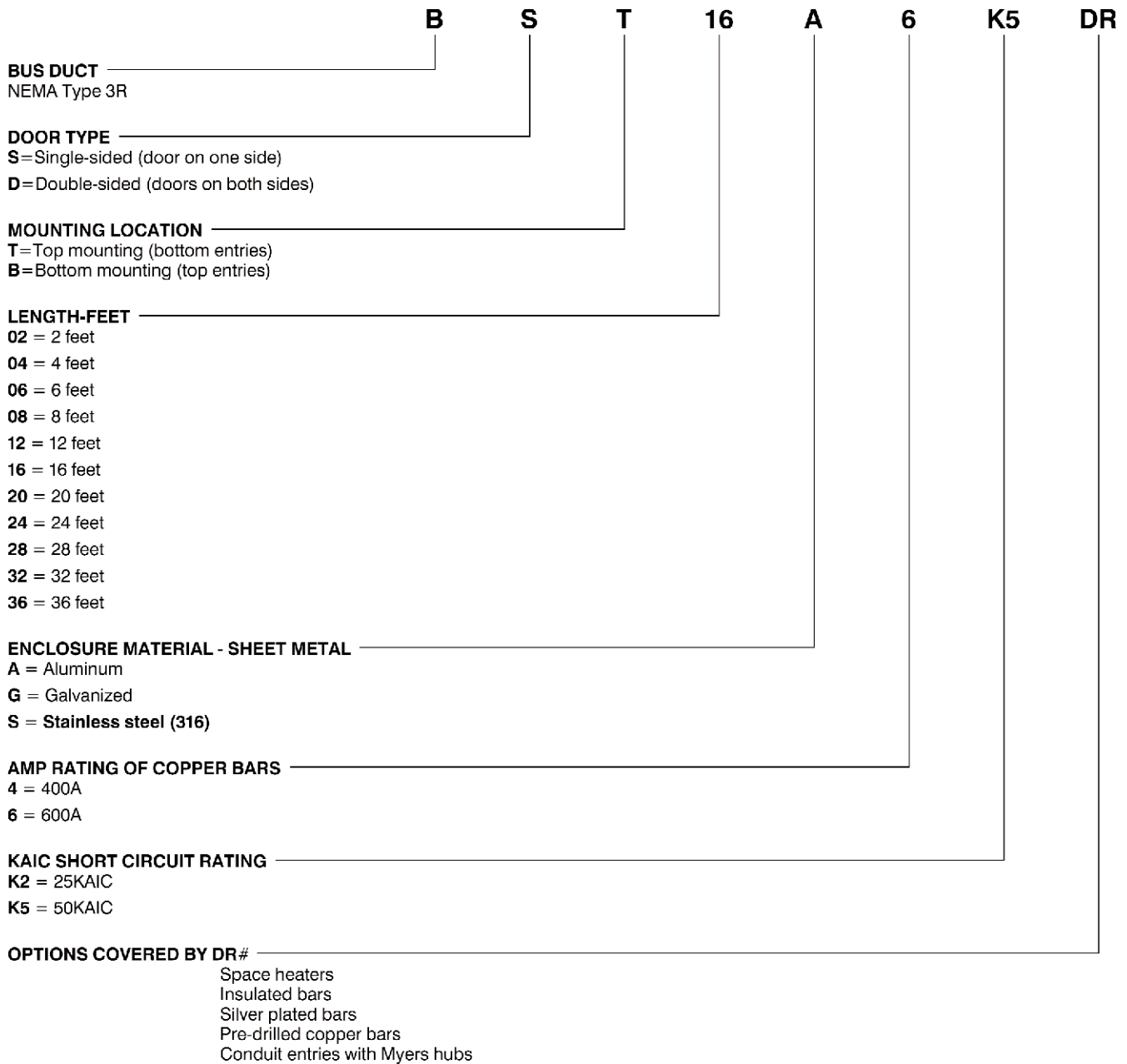

One (1) drain is standard per bus duct (termination box) section.

*For pricing and lead times, contact Cooper Crouse-Hinds at 315 477-5241 or fax to 315 477-5118.



CHS Controls AB
 Florettgatan 33
 SE-254 67 Helsingborg, Sweden
 Tel +46 42 38 61 00, Fax +46 42 38 61 29
 chs@chscontrols.se
 www.chscontrols.se

7C

Cl. I, Div. 1 & 2, Groups B, C, D
 Cl. II, Div. 1, Groups E, F, G
 Cl. II, Div. 2, Groups F, G
 Cl. III
 NEMA 3, 4X, 7BCD, 9EFG, 12

Explosionproof
 Dust-Ignitionproof
 Raintight
 Wet Locations
 Watertight

Selection Guide

Customer: _____ Engineering Firm: _____
 Project: _____ Location: _____
 Prepared By: _____ Date: _____
 Quotation For: Estimate/Budget Bid Immediate Buy
 Quotation Required By (Date) _____ Material Required By (Date) _____

Interested in a highly reliable, comprehensive communications that will improve the operating efficiency of your facility? See additional information at the end of this guide.

Is a current copy of plant STDS/SPECS available to Cooper Crouse-Hinds? _____

7C

Area Classification:

HAZARDOUS - Circle All that apply:

- Class I
Div. 1 or 2, Grps B,C & D
- Class II
Div. 1 or 2, Grps E,F & G
- Class III

NON-HAZARDOUS

- Ordinary Locations
- NEMA 3R, 4, 4X (Circle One)

Structural Frame:

MATERIAL

- Steel
- Aluminum
- Single Face
(Components on ONE side only)
- Double Face
(Components on BOTH sides)
- Other _____
- Percent Spare Space _____ %

FINISH

- Hot Dip Galvanized
- Painted

Roof Canopy:

- Yes No
- Corrugated Aluminum
- Corrugated Fiberglass

Enclosure Type:

- Bolted Threaded
- Krydon Epoxy Coated

Dimension Restrictions:

- Length _____ Height _____

Service System: (i.e. 480V, 3PH, 3W, 60HZ)

_____ VOLT _____ PH _____ W _____ HZ

Incoming Feeder Requirements:

- _____ # Conductors/Phase
- _____ # AWG/MCM
- _____ # Inch Conduit (Size)
- Top Entry Bottom Entry

Main Bus Enclosure:

MATERIALS

- Steel
- Aluminum
- Other (Specify) _____
- Bus Location - Top of Rack
- Bus Location Bottom of Rack
- Bus Bracing _____ (25 KAIC Standard)
- Bus Amps _____
- Other - Customer to Specify

FINISH

- Hot Dip Galv.
- Painted

MAIN BUS CHARACTERISTICS

- Copper Bars Power Distr. Block
- Bare (Standard) Ground Bus in Enclosure
- Insulated
- Silver Plated
- Tin Plated



CHS Controls AB
 Florettgatan 33
 SE-254 67 Helsingborg, Sweden
 Tel +46 42 38 61 00, Fax +46 42 38 61 29
 chs@chscontrols.se
 www.chscontrols.se

Switch Rack Assemblies

Cl. I, Div. 1 & 2, Groups B, C, D
 Cl. II, Div. 1, Groups E, F, G
 Cl. II, Div. 2, Groups F, G
 Cl. III
 NEMA 3, 4X, 7BCD, 9EFG, 12

Explosionproof
 Dust-Ignitionproof
 Raintight
 Wet Locations
 Watertight

7C

Selection Guide

Main Breaker/Disconnect: (3C,N)

None Molded Case Breaker
 AIC Rating _____
 Amp Trip (AT)/ _____ Amp Frame (AF) _____
 Disconnect Switch
 _____ Amps
 Fused Non-Fused

Equipment Requirements:

COMBINATION MOTOR STARTERS (1C, N)

FVNR, Reversing, 2-speed (circle one)
 Qty. _____

_____ NEMA Size 0 with _____ AT/ _____ AF, _____ MCP
 _____ NEMA Size 1 with _____ AT/ _____ AF, _____ MCP
 _____ NEMA Size 2 with _____ AT/ _____ AF, _____ MCP
 _____ NEMA Size 3 with _____ AT/ _____ AF, _____ MCP
 _____ NEMA Size 4 with _____ AT/ _____ AF, _____ MCP
 _____ NEMA Size 5 with _____ AT/ _____ AF, _____ MCP
 _____ NEMA Size 6 with _____ AT/ _____ AF, _____ MCP

Refer to Cooper Crouse-Hinds catalog for suggested breaker or motor circuit protector sizing if not specified above, Cooper Crouse-Hinds will size accordingly.

OPTIONS REQUIRED

*Unless specified differently *options furnished standard

	Yes	No
*Fused Control Transformer Suffix FTFS	_____	_____
Space Heaters Suffix R11, R22, R44	_____	_____
Start/Stop Pushbuttons Suffix PB23	_____	_____
Hand-Off Auto Selection Switch Suffix RR3	_____	_____
Red Indicating Light Suffix J1	_____	_____
Green Indicating Light Suffix J3	_____	_____
*Auxiliary Contacts: (2 N.O./2NC) Suffix S782	_____	_____
Control Relay Suffix S787	_____	_____
*Breather/Drain Suffix S198V/S756V	_____	_____
*12 Point Terminal Block Other - Specify Suffix S786	_____	_____

‡ Not available with D2PB panelboards.

Feeder Circuit Breaker: (3C, N)

AIC Rating _____
 Qty _____ (AT) _____ (Specify) _____
 _____ /100/150 AF
 _____ /100/150 AF
 _____ /225/250 AF
 _____ /400 AF
 _____ /800 AF
 _____ Other

Component Preference:

Cutler-Hammer SQD A-B GE
 (Cutler-Hammer will be used if no preference is indicated.)

Distribution Transformers:

_____ KVA _____ PH _____ Volt-Pri _____ / _____ Volt-Sec
 _____ KVA _____ PH _____ Volt-Pri _____ / _____ Volt-Sec
 Copper Windings Stainless Steel Enclosure

Panelboards: (1A, N)

Power (480V) (D2D EXD)
 Single Phase Three Phase
 Main Breaker _____ Pole _____ AT
 Branch Circuits
 Qty _____ AT _____ No. Poles (i.e. '2P'-2 = Pole) _____

LIGHTING/HEAT TRACING

(240/120V) (D2L, EPL, D2PB)
 Single Phase Three Phase
 Main Breaker _____ Pole _____ AT
 Branch Circuits
 Qty _____ (AT) _____ No. Poles (i.e. '2P'=2 Pole) _____

 ‡ GFI (5mA) _____ AMP
 (No. Req'd) _____ Rating _____
 ‡ EPD (30mA) _____ AMP
 (No. Req'd) _____ Rating _____



CHS Controls AB
 Florettgatan 33
 SE-254 67 Helsingborg, Sweden
 Tel +46 42 38 61 00, Fax +46 42 38 61 29
 chs@chscontrols.se
 www.chscontrols.se

Cl. I, Div. 1 & 2, Groups B, C, D Explosionproof
 Cl. II, Div. 1, Groups E, F, G Dust-Ignitionproof
 Cl. II, Div. 2, Groups F, G Raintight
 Cl. III Wet Locations
 NEMA 3, 4X, 7BCD, 9EFG, 12 Watertight

Selection Guide

Lighting Contactor:

- Yes No
- No. Poles _____ Amp Rating _____
- Control Power Transformer
Suffix FTPS
- Hand-Off-Auto Selector Switch
Suffix RR3

Photocell:

- Yes No

Lighting Fixtures: (1L, 2L, 3L)

Quantity _____ Type _____
 Wattage _____ Voltage _____

Receptacles:

- Convenience Receptacle
Amps _____ Poles _____ Volts _____
- Welding Receptacle
Amps _____ Poles _____ Volts _____
- Integral Circuit Breaker Yes No

Conduit Fittings, Seals, Unions:

- Plant Standard _____ (i.e."Form 7")
- Iron Aluminum
- Type Seals
(Note seals not poured at factory)
- EYD EYS EZD
- Other (specify) _____

Conduit:

- Rigid Galv. Steel Aluminum
- PVC Coated

Wiring:

- RHW/RHH THWN/THHN (C-H Std)
- THW XHHW
- Other Insulation - Specify _____

Shop Inspection & Tests:

- Mfr. Standard Tests
- Customer In Plant Final Inspection
- Yes No

*Utilizing Standard Cooper Crouse-Hinds NEMA 7 Enclosures with specified internal components (mounted on your switchrack) this state-of-the-art technology is available today. IMPACC (Integrated Monitoring Protection and Control Communications), by Cutter-Hammer/Westinghouse is a unique high frequency-based communications system specially designed for electrical distribution and control applications. Providing real time information, with an "open" protocol, allows you to manage and operate your entire electrical system including remote hazardous areas without leaving your office or motor control centre. For more information, contact us.

Special Requirements: _____



CHS Controls AB
 Florettgatan 33
 SE-254 67 Helsingborg, Sweden
 Tel +46 42 38 61 00, Fax +46 42 38 61 29
 chs@chscontrols.se
 www.chscontrols.se